

EL180UHNE series units are mid-efficiency gas furnaces used for upflow or horizontal applications only, manufactured with Lennox Duralok™ heat exchangers formed of aluminized steel. EL180UHNE units are available in heating capacities of 40,000 to 100,000 Btuh and cooling applications 2 to 5 tons. Refer to Engineering Handbook for proper sizing.

EL180UHNE model units are equipped with a hot surface ignition system. The EL180UHNE unit meets the new California 14 ng/J Nitrogen Oxides (NO_x) Standards and California Seasonal Efficiency requirements. All units use a redundant gas valve to assure safety shut-off as required by C.S.A.

All specifications in this manual are subject to change. Procedures outlined in this manual are presented as a recommendation only and do not supersede or replace local or state codes. In the absence of local or state codes, the guidelines and procedures outlined in this manual (except where noted) are recommended only and do not constitute code.

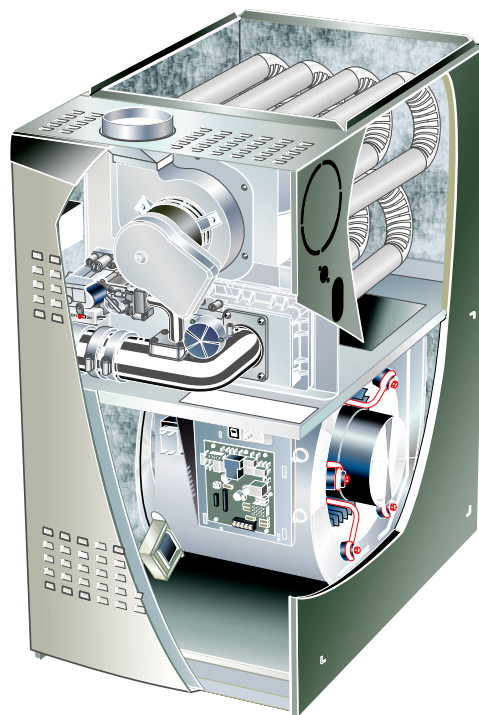

⚠ CAUTION

As with any mechanical equipment, contact with sharp sheet metal edges can result in personal injury. Take care while handling this equipment and wear gloves and protective clothing.

TABLE OF CONTENTS

Specifications	Page 2
Blower Data	Page 3
Parts Identification	Page 5
I Unit Components	Page 6
II Installation	Page 17
III Start Up	Page 17
IV Heating System Service Checks	Page 17
V Typical Operating Characteristics	Page 21
VI Maintenance	Page 21
VII Wiring and Sequence of Operation	Page 24

⚠ WARNING

Improper installation, adjustment, alteration, service or maintenance can cause property damage, personal injury or loss of life. Installation and service must be performed by a licensed professional HVAC installer (or equivalent), service agency or the gas supplier.

⚠ WARNING



Electric shock hazard. Can cause injury or death. Before attempting to perform any service or maintenance, turn the electrical power to unit OFF at disconnect switch(es). Unit may have multiple power supplies.

SPECIFICATIONS

Gas Heating Performance		Model No.	EL180UH040NE36A	EL180UH060NE36A	EL180UH080NE48B	EL180UH100NE60C
		¹ AFUE	80%	80%	80%	80%
		Input - Btuh	40,000	60,000	80,000	100,000
		Output - Btuh	32,700	49,000	70,500	81,500
		Temperature rise range - °F	20 - 50	30 - 60	35 - 65	35 - 65
		Gas Manifold Pressure (in. w.g.) Natural Gas Only	1.8	3.4	3.4	304
		High Static - in. w.g.	0.50	0.50	0.50	0.50
Connections in.		Flue connection - in. round	4	4	4	4
		Gas pipe size IPS	1/2	1/2	1/2	1/2
Indoor Blower		Wheel nominal dia. x width - in.	10 x 8	10 x 10	10 x 10	11-1/2 x 10
		Motor Type	DC Brushless	DC Brushless	DC Brushless	DC Brushless
		Motor output - hp	1/2	1/2	3/4	1
		Tons of add-on cooling	1.5 - 3	1.5 - 3	2.5 - 4	3 - 5
		Air Volume Range - cfm	350 - 1380	395 - 1415	750 - 1785	920 - 2315
		Electrical Data	Voltage	120 volts - 60 hertz - 1 phase		
		Blower motor full load amps	6.8	6.8	8.4	10.9
		Maximum overcurrent protection	15	15	15	15
Shipping Data		lbs. - 1 package	100	113	125	149

NOTE - Filters and provisions for mounting are not furnished and must be field provided.

¹ Annual Fuel Utilization Efficiency based on DOE test procedures and according to FTC labeling regulations. Isolated combustion system rating for non-weatherized furnaces.

OPTIONAL ACCESSORIES - ORDER SEPARATELY

NOTE - FURNACES CANNOT BE TWINNED!

		"A" Width Models	"B" Width Models	"C" Width Models	
CABINET ACCESSORIES					
Horizontal Suspension Kit - Horizontal only		51W10	51W10	51W10	
Return Air Base - Upflow only		65W75	50W98	50W99	
High Performance Economizer (Commercial Only)		10U53	10U53	10U53	
CONTROLS					
Blower Relay Kit (for two-stage outdoor units)		85W66	85W66	85W66	
FILTERS					
¹ Air Filter and Rack Kit	Horizontal (end)	87L95	87L96	87L97	
	Size of filter - in.	14 x 25 x 1	18 x 25 x 1	20 x 25 x 1	
	Side Return	Single	44J22	44J22	44J22
		Ten Pack	66K63	66K63	66K63
	Size of filter - in.	16 x 25 x 1	16 x 25 x 1	16 x 25 x 1	
SERVICE KIT					
Night Service Kit		84W47	84W47	84W47	
VENTING					
Vent Adaptor - 6 in. conn. size upflow applications only		18M79	18M79	18M79	

¹ Cleanable polyurethane, frame-type filter.

BLOWER DATA

EL180UH040NE36A PERFORMANCE (Less Filter)

External Static Pressure in. w.g.	Air Volume / Watts at Various Blower Speeds									
	High		Medium-High		Medium		Medium-Low		Low	
	cfm	Watts	cfm	Watts	cfm	Watts	cfm	Watts	cfm	Watts
0.00	1430	243	1200	140	1025	86	945	66	945	45
0.10	1395	253	1165	151	1005	99	940	75	930	50
0.20	1370	264	1130	157	930	99	825	80	795	68
0.30	1345	278	1100	170	895	110	775	85	650	63
0.40	1320	289	1085	182	875	120	745	90	615	70
0.50	1295	302	1035	189	820	126	705	102	545	76
0.60	1245	308	1010	200	795	135	655	107	515	85
0.70	1220	320	980	210	755	147	615	115	445	87
0.80	1200	332	930	215	700	152	570	121	400	95

EL180UH060NE36A PERFORMANCE (Less Filter)

External Static Pressure in. w.g.	Air Volume / Watts at Various Blower Speeds									
	High		Medium-High		Medium		Medium-Low		Low	
	cfm	Watts	cfm	Watts	cfm	Watts	cfm	Watts	cfm	Watts
0.00	1410	243	1190	141	1030	86	930	73	835	55
0.10	1380	251	1165	150	990	95	890	89	790	65
0.20	1360	264	1115	158	950	99	840	78	730	68
0.30	1315	278	1090	171	910	110	790	89	660	61
0.40	1295	290	1070	182	865	122	740	93	600	71
0.50	1270	300	1025	191	825	127	695	103	545	75
0.60	1235	300	1000	197	785	136	650	108	495	84
0.70	1215	317	975	208	750	147	615	118	450	88
0.80	1185	331	920	216	700	153	555	121	390	96

EL180UH080NE48B PERFORMANCE (Less Filter)

External Static Pressure in. w.g.	Air Volume / Watts at Various Blower Speeds									
	High		Medium-High		Medium		Medium-Low		Low	
	cfm	Watts	cfm	Watts	cfm	Watts	cfm	Watts	cfm	Watts
0.00	1785	344	1570	236	1455	183	1390	161	1230	116
0.10	1745	360	1535	249	1420	194	1360	172	1190	129
0.20	1725	373	1500	266	1375	212	1310	189	1145	135
0.30	1695	386	1475	279	1340	224	1280	201	1100	146
0.40	1665	405	1440	293	1305	237	1235	208	1065	156
0.50	1640	418	1410	307	1275	250	1190	223	1015	170
0.60	1595	433	1370	323	1235	263	1160	234	970	182
0.70	1570	446	1330	336	1190	277	1120	249	930	187
0.80	1530	461	1300	349	1155	289	1095	260	900	201

BLOWER DATA

EL180UH100NE60C (Less Filter)

External Static Pressure in. w.g.	Air Volume / Watts at Different Blower Speeds																			
	Bottom Return Air, Side Return Air with Return Air from Both Sides or Return Air from Bottom and One Side.										Single Side Return Air – Air volumes in bold require Optional Return Air Base <u>and</u> field fabricated transition to accommodate 20 x 25 x 1 in. air filter in order to maintain proper air velocity.									
	High		Med-High		Medium		Med-Low		Low		High		Med-High		Medium		Med-Low		Low	
	cfm	Watts	cfm	Watts	cfm	Watts	cfm	Watts	cfm	Watts	cfm	Watts	cfm	Watts	cfm	Watts	cfm	Watts	cfm	Watts
0.00	2205	623	1950	415	1710	275	1575	220	1425	160	2235	595	1945	382	1725	262	1590	202	1430	165
0.10	2175	639	1910	427	1685	287	1545	234	1400	176	2205	611	1915	397	1695	280	1550	218	1400	193
0.20	2145	658	1885	449	1635	309	1490	246	1325	181	2165	629	1885	424	1660	293	1510	235	1335	175
0.30	2100	681	1845	466	1605	327	1465	259	1275	196	2135	652	1850	441	1615	312	1475	247	1275	182
0.40	2095	700	1815	481	1565	337	1415	280	1225	204	2085	676	1800	456	1580	330	1430	261	1240	197
0.50	2045	717	1780	499	1525	356	1375	286	1195	218	2055	685	1775	474	1535	347	1395	281	1195	206
0.60	2025	737	1735	516	1500	374	1350	304	1145	230	2025	700	1755	494	1505	359	1355	300	1155	222
0.70	1995	746	1715	533	1465	389	1320	323	1090	248	1990	720	1725	515	1480	377	1310	308	1120	237
0.80	1950	769	1675	547	1430	401	1255	331	1065	259	1965	742	1685	532	1445	396	1275	325	1060	248

PARTS ARRANGEMENT

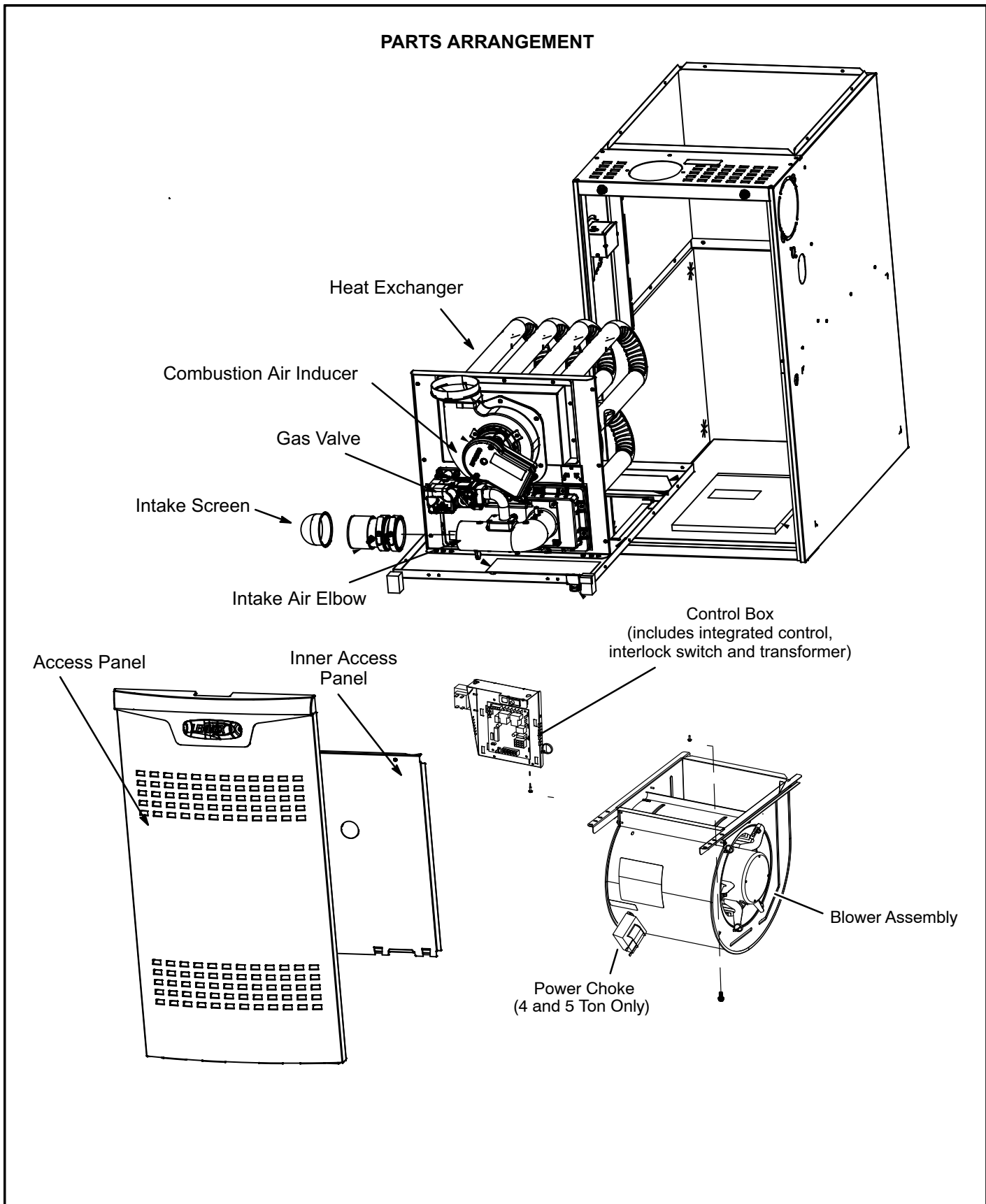

FIGURE 1

I-UNIT COMPONENTS

EL180UHNE unit components are shown in figure 1. The gas valve, combustion air inducer and burners can be accessed by removing the upper access panel. Electrical components are in the control box (figure 2) found in the blower section.

⚠ CAUTION

Electrostatic discharge can affect electronic components. Take precautions to neutralize electrostatic charge by touching your hand and tools to metal prior to handling the control.

1. Control Transformer (T1)

A transformer located in the control box provides power to the low voltage section of the unit. Transformers on all models are rated 40VA with a 120V primary and a 24V secondary.

2. Door Interlock Switch (S51)

A door interlock switch is wired in series with line voltage. When the blower door is removed the unit will shut down.

NOTE - The door interlock switch is a safety switch. Do not by-pass or jumper switch.

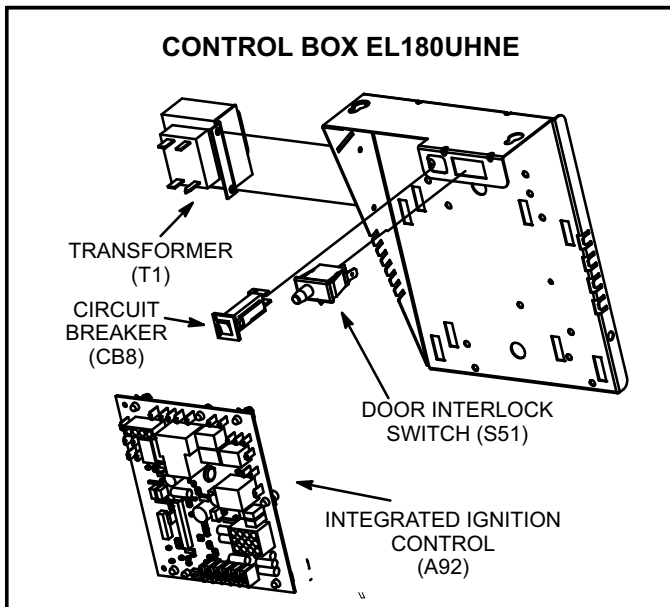

FIGURE 2

3. Circuit Breaker (CB8)

A 24V circuit breaker is also located in the control box. The switch provides overcurrent protection to the transformer (T1). The breaker is rated at 3A at 32V. If the current exceeds this limit the breaker will trip and all unit operation will shutdown. The breaker can be manually reset by pressing the button on the face.

4. Integrated Control (A92)

⚠ WARNING

Shock hazard.

Disconnect power before servicing. Control is not field repairable. If control is inoperable, simply replace entire control.

Can cause injury or death. Unsafe operation will result if repair is attempted.

The hot surface ignition control system consisting of an integrated control (figure 3 with control terminal designations in tables 1, 2 and 3), sensor and ignitor (figure 6). The integrated control and ignitor work in combination to ensure furnace ignition and ignitor durability. The integrated control, controls all major furnace operations. The integrated control also features a RED LED for troubleshooting and two accessory terminals rated at (1) one amp. See table 4 for troubleshooting diagnostic codes. The nitride ignitor is made from a non-porous, high strength proprietary ceramic material that provides long life and trouble free maintenance.

Electronic Ignition (Figure 4)

On a call for heat the integrated control monitors the combustion air inducer pressure switch. The control will not begin the heating cycle if the pressure switch is closed (bypassed). Once the pressure switch is determined to be open, the combustion air inducer is energized. When the differential in the pressure switch is great enough, the pressure switch closes and a 15-second pre-purge begins. If the pressure switch is not proven within 2-1/2 minutes, the integrated control goes into Watchguard-Pressure Switch mode for a 5-minute re-set period.

After the 15-second pre-purge period, the ignitor warms up for 20 seconds during which the gas valve opens at 19 seconds for a 4-second trial for ignition. The ignitor remains energized for the first 3 seconds during the 4 second trial. If ignition is not proved during the 4-second period, the integrated control will try four more times with an inter purge and warm-up time between trials of 35 seconds. After a total of five trials for ignition (including the initial trial), the integrated control goes into Watchguard-Flame Failure mode. After a 60-minute reset period, the integrated control will begin the ignition sequence again.

TABLE 1

4-Pin Terminal Designation	
PIN #	FUNCTION
1	Combustion Air Inducer Line
2	Ignitor Line
3	Combustion Air Inducer Neutral
4	Ignitor Neutral

TABLE 2

12-Pin Terminal Designations	
PIN #	FUNCTION
1	High Limit Output
2	Not Used
3	24V Line
4	Not Used
5	Rollout Switch Out
6	24V Neutral
7	High Limit Input
8	Ground
9	Gas Valve Common
10	Pressure Switch In
11	Rollout Switch In
12	Gas Valve Out

TABLE 3

1/4" QUICK CONNECT TERMINALS	
120HUM	Humidifier 120VAC
LINE	120VAC
XFMR	Transformer 120VAC
CIRC	Indoor blower 120VAC
EAC	Indoor air quality accessory 120VAC
NEUTRALS	Common 120VAC
HUM24	Humidifier 24VAC
3/16" QUICK CONNECT TERMINALS	
COOL	Cooling tap 24VAC
HEAT	Heating tap 24VAC
FAN	Continuous blower 24 VAC
PARK (no power)	Park terminal for speed taps
FS	Flame sense
24 COM	Common 24VAC

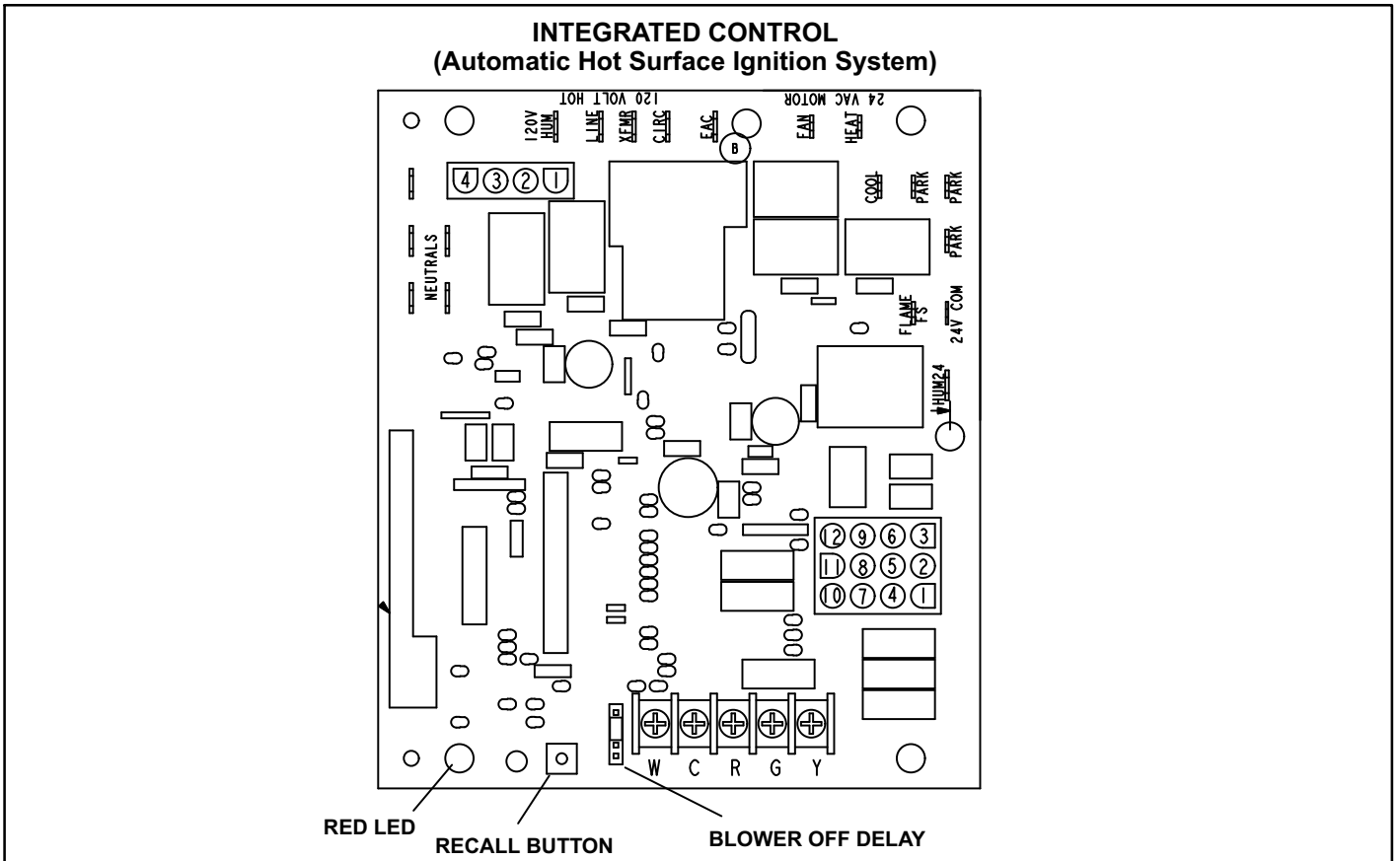

TABLE 4

The integrated control is equipped with an LED light for troubleshooting. The diagnostic codes are listed below in table 4.

RED LED Flash Code²	Diagnostic Codes / Status of Furnace
Off	No power to control or board fault detected
Heartbeat ¹	Normal Operation - Idle, Continuous Fan, Cool
Continuous Rapid Flash	Call For Heat / Burner Operation
1	Reverse Line Voltage Polarity
2	Improper Earth Ground
3	Burner failed to light, or lost flame during heat demand
4	Low Flame Signal - check flame sensor
5	Watchguard - burner failed to light, exceeded maximum number of retries or recycles.
6	Ignitor Circuit Failure - not available on this control
7	Primary or Secondary Limit Open or Watchguard Mode - Limit Switch Open longer than 3 minutes
8	Rollout Switch Open
9	Pressure Switch failed to close or opened during heat demand
10	Watchguard - Pressure Switch opened 5 times during one heat demand
11	Pressure Switch stuck closed prior to activation of combustion air inducer
12	Flame Sensed without gas valve energized
13	Low Line Voltage
Notes	
Note 1	A "Heartbeat" is indicated by a "Slow Flash" - 1 sec on 1 sec off, repeating
Note 2	Error codes are indicated by a "rapid flash" - the LED flashes X times at ½ second on ½ second off, remains off for 3 seconds then repeats.
Note 3	Last 10 error codes are stored in memory including when power is shut off to the unit. - To recall, press and release button, most recent will be displayed first, LED off for 3 sec, then next error code is displayed, etc. To clear error codes, depress and hold button longer than 5 seconds.

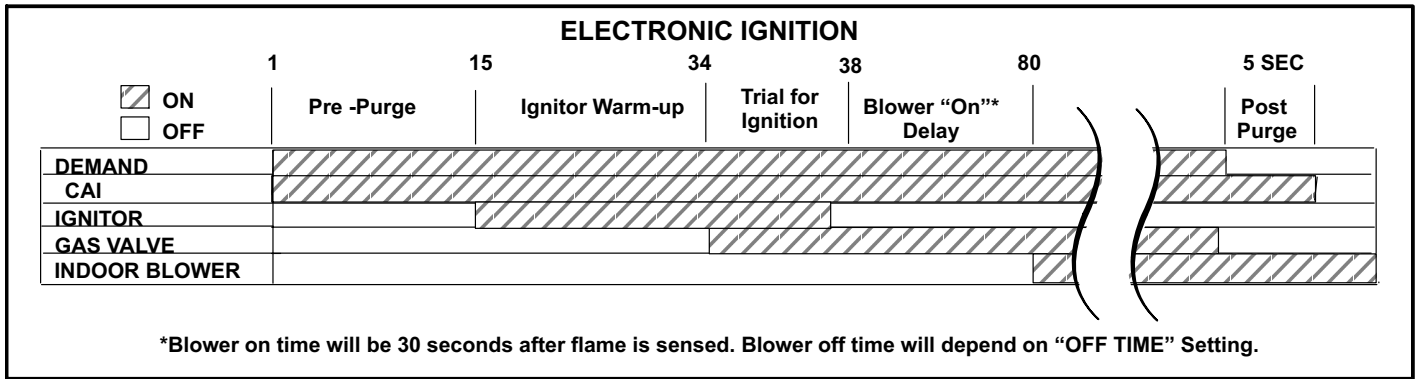

FIGURE 4

Fan Time Control

Heating Fan On Time

The fan on time of 30 seconds is not adjustable.

Heating Fan Off Time

Fan off time (time that the blower operates after the heat demand has been satisfied) can be adjusted by moving the jumper to a different setting. The unit is shipped with a factory fan off setting of 90 seconds. For customized comfort, monitor the supply air temperature once the heat demand is satisfied. Note the supply air temperature at the instant the blower is de-energized.

Adjust the fan-off delay to achieve a supply air temperature between 90° - 110° at the instant the blower is de-energized. (Longer delay times allow for lower air temperature, shorter delay times allow for higher air temperature). See figure 5.

Cooling Fan On Time

The fan on time is 2 seconds and is not adjustable.

Cooling Fan Off Time

The control has a 45 second fan off delay after cooling demand has been met. This delay is factory set and not adjustable.

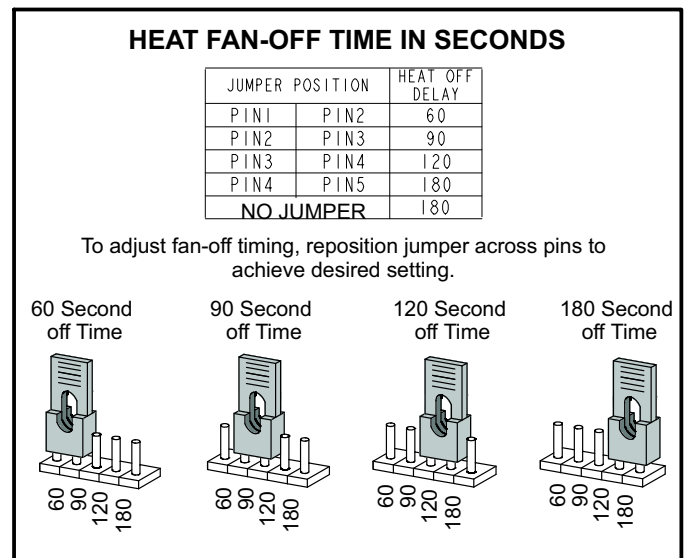

FIGURE 5

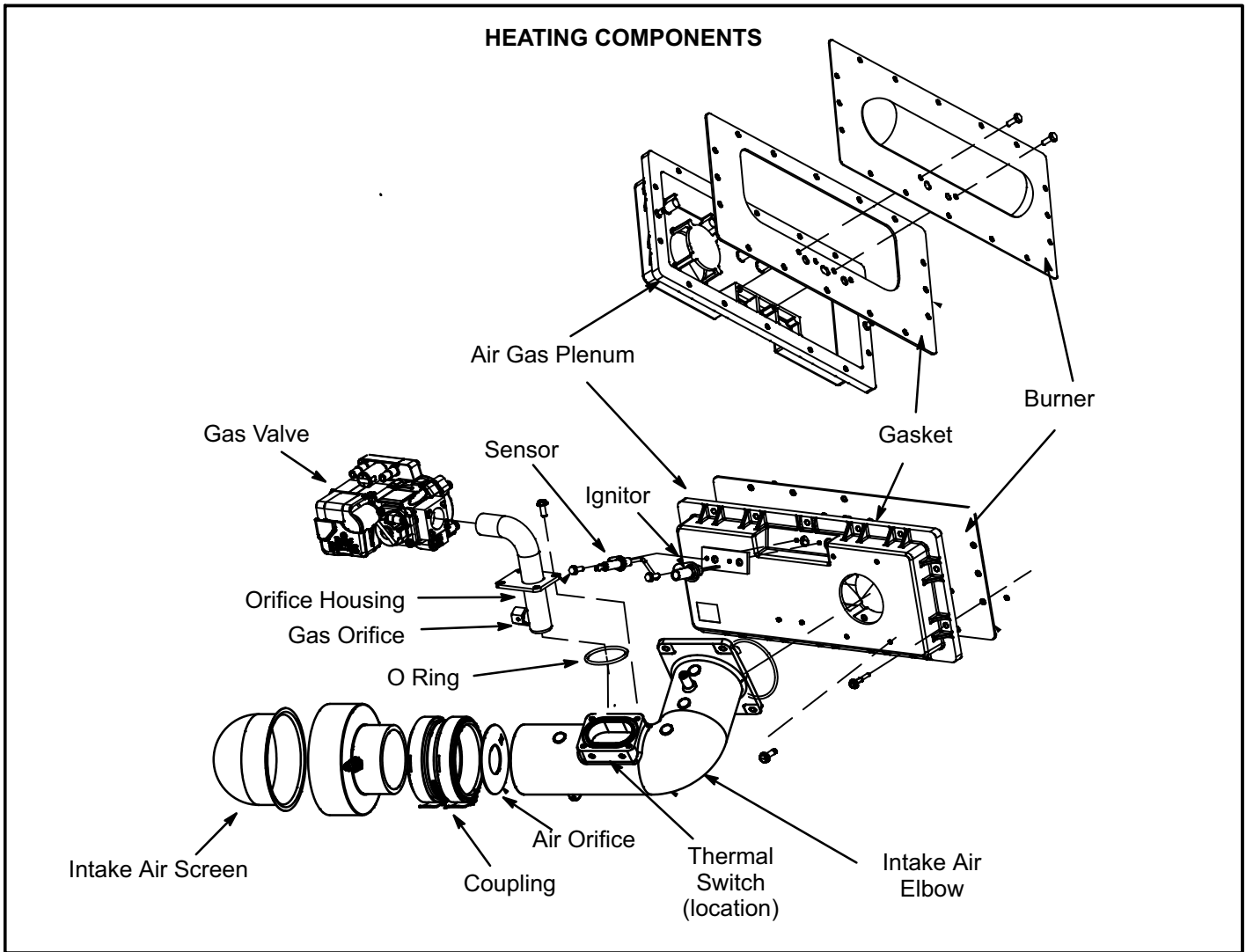

FIGURE 6

5. Thermal Switch (Figure 6)

The auto-reset switch is located on the front of the intake air elbow. The switch will safely shut the unit down if excessive temperatures are detected. When the switch senses excessive temperature, the circuit breaks and the ignition control immediately stops ignition and closes the gas valve.

6. Primary Limit Control

The primary limit (S10) is located in the heating vestibule panel. When excess heat is sensed in the heat exchanger, the limit will open. If the limit is open, the furnace control energizes the supply air blower and closes the gas valve. The limit automatically resets when unit temperature returns to normal. The switch must reset within three minutes or the SureLight control will go into Watch guard for one hour. The switch is factory set and cannot be adjusted. The switch may have a different set point for each unit model number. See Lennox Repair Parts Handbook if limit switch must be replaced.

7. Gas Valve (Figure 6)

The valve is internally redundant to assure safety shut-off. If the gas valve must be replaced, the same type valve must be used.

24VAC terminals and gas control knob are located on the valve. A wire harness connects the terminals from the gas valve to the electronic ignition control. 24V applied to the terminals energizes the valve. Inlet and outlet pressure taps are located on the valve. A regulator adjustment screw is located on the valve.

EL180UHN units are equipped with a Honeywell gas valve rated for ambient temperatures between -40° F and +175° F.

8. Flame Sensor (Figure 6)

A flame sensor is located on the top of the air gas plenum. The sensor can be removed for service without removing the burner. During operation, flame is sensed by current passed through the flame and sensing electrode. The SureLight control allows the gas valve to remain open as long as flame signal is sensed. To check flame sense signal use the push-button found on the integrated control and go to Field Test Mode. The menu will display the flame signal. See Table 15 for flame signal.

TABLE 5

Flame Signal in Microamps		
Normal	Low	Drop Out
1.5 or greater	0.5 - 1.4	0.4 or less

9. Combustion Air Inducer (B6)

All EL180UHNE units use a combustion air inducer to move air through the burners and heat exchanger during heating operation. The blower uses a 120VAC motor. The motor operates during all heating operation and is controlled by integrated control A92. The inducer also operates for 15 seconds before burner ignition (pre-purge) and for 5 seconds after the gas valve closes (post-purge).

10. Combustion Air Inducer Prove Switch (S18)

EL180UHNE series units are equipped with a combustion air pressure switch (figure 7) located near the gas valve. The switch is connected to the combustion air inducer housing by means of a flexible silicone hose. It monitors negative air pressure in the intake air elbow.

The switch is a single-pole single-throw proving switch electrically connected to the furnace control. The purpose of the switch is to prevent burner operation if the combustion air inducer is not operating or if the flue becomes obstructed.

On heat demand the switch senses that the combustion air inducer is operating. It closes a circuit to the integrated control when pressure inside the combustion air inducer decreases to a certain set point. The pressure sensed by the switch is negative relative to atmospheric pressure. If the flue becomes obstructed during operation, the switch senses a loss of pressure difference and opens the circuit to the furnace control and gas valve. See table 6 for set point.

If replacing the inducer switch or tubing is necessary, make note of the tubing connections to the gas valve. See figure 8.

NOTE - The switch is factory set and is not field adjustable. It is a safety shut-down control in the furnace and must not be by-passed for any reason. If switch is closed or by-passed, the control will not initiate ignition at start up.

TABLE 6
Prove Switch Set Points

EL180 Model	Make inches w.c.	Break inches w.c.
040	0.35	0.20
060	0.35	0.20
080	0.35	0.20
100	0.35	0.20

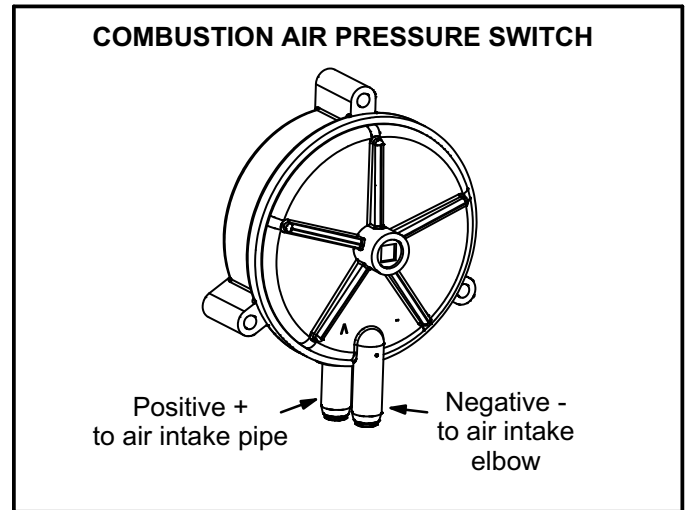

FIGURE 7

11. Burner and Orifice

Burners are factory set and require no adjustment. Always operate the unit with air gas plenum in place. The burner has one orifice located between the gas valve and the air intake assembly (Figure 6). To check or replace the orifice remove the intake air screen, coupling and intake air elbow. Using a 5/8" socket, go through the elbow and unscrew the gas orifice. The burner uses an orifice (see Table 7) that is precisely matched to the burner input. The burner can be removed for service. If burner has been removed, it is critical to replace all gaskets.

TABLE 7

Gas Orifice Nat Gas	
Unit Input	Orifice Size
40	0.0595
60	0.0595
80	0.0689
100	0.0810

12. Ignitor (Figure 6)

The SureLight® ignitor is made of durable silicon nitride. Ignitor longevity is enhanced by controlling voltage to the ignitor. The integrated control provides a regulated 120 volts to the ignitor for a consistent ignition and long ignitor life. Ohm value should be 39 to 70.

See figure 9 for resistance, and voltage check.

NOTE - The EL180UHNE furnace contains electronic components that are polarity sensitive. Make sure that the furnace is wired correctly and is properly grounded.

Replacing the Pressure Switch or Tubing

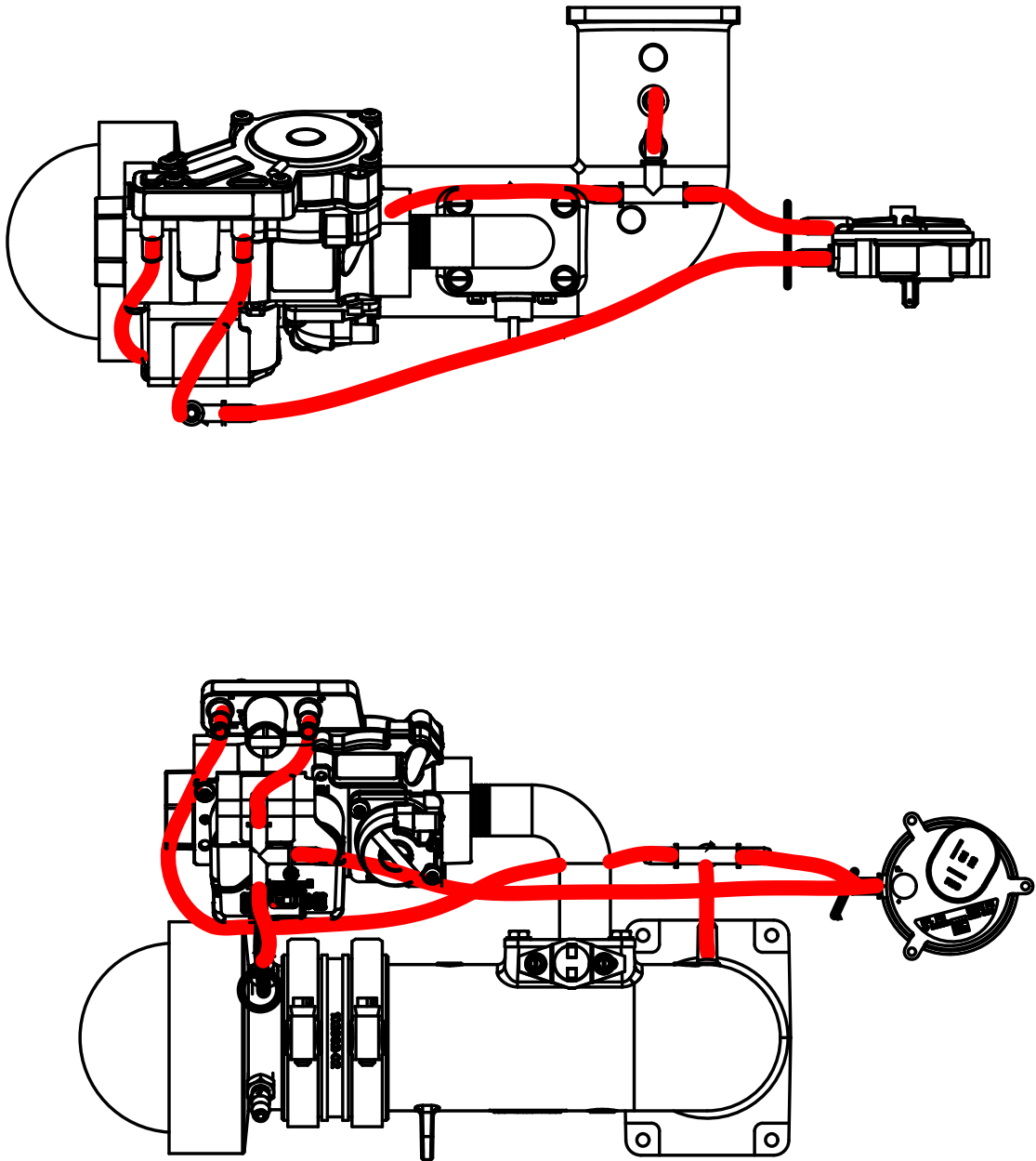

FIGURE 8

Ignitor Check Out

Test 1

Remove 5-pin plug from control
Check ohms reading across terminals 1 and 5
Ohm value should be between 39 - 70.

Meter
(set to ohms)

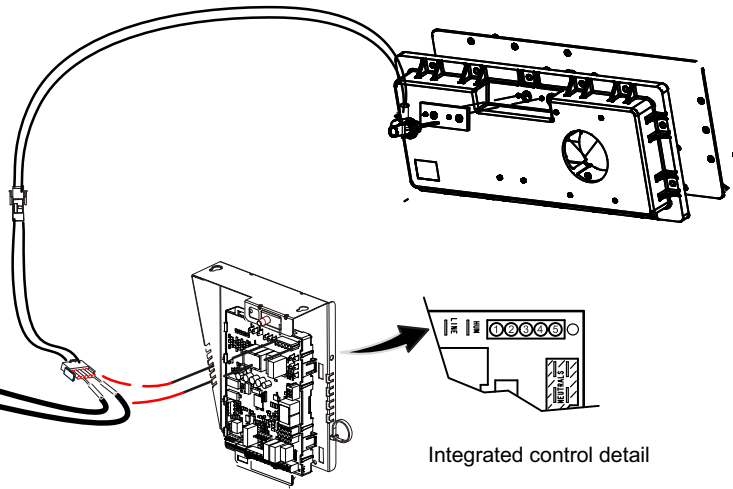
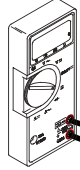

Integrated control detail

Test 2

Separate the 2-pin jack plug near the manifold and check resistance of the ignitor. If the reading is correct, then there is a problem with the wiring between the jack plug and control. If the reading is not correct the issue is the ignitor.

Meter
(set to ohms)

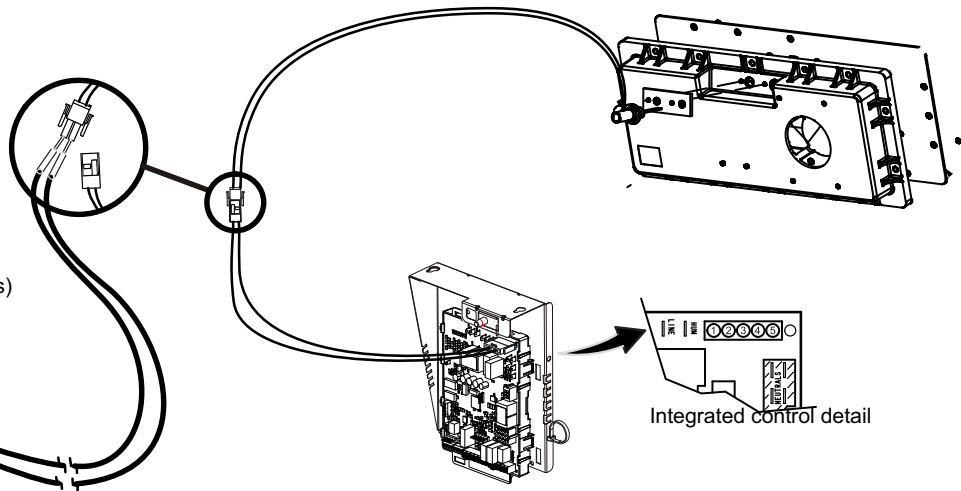

Integrated control detail

Test 3

Insert meter probes into the terminals 1 and 5. (Use small diameter probes in order to not damage plug). Check voltage during 20 second warm up period. Voltage should read 120 volts \pm 10%. If voltage is above these values, check for correct supply voltage to furnace.

Meter
(set to AC volts)

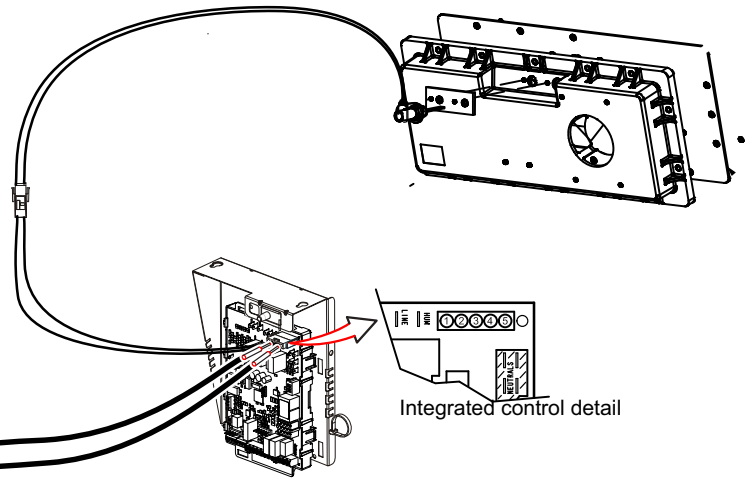
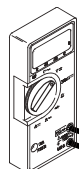

Integrated control detail

FIGURE 9

13. Blower Motor

⚠ IMPORTANT

Each blower is statically and dynamically balanced as an assembly before installation in the unit.

EL180UHNE units are equipped with a constant torque ECM motor. It has a DC motor coupled to an electronic control module both contained in the same motor housing. The motor is programmed to provide constant torque at each of the five selectable speed taps. Each tap requires 24 volts to energize.

Input Voltage Requirements

The circuit is designed to be operated with AC voltage. To enable a tap requires 12 to 33VAC. Expected current draw will be less than 20mA.

Troubleshooting the Motor

Troubleshooting the motor is an easy process. Follow steps below.

- 1- Shut off power to unit.
- 2- Remove input plugs P48 and P49 from motor. See figure 12 for troubleshooting procedure.

If correct voltage is present in tests 1 and 2 and motor is not operating properly, replace motor. The motor is not field repairable.

If replacing the indoor blower motor or blower wheel is necessary, placement is critical. The blower wheel must be centered in the blower housing as shown in figure 10. When replacing the indoor blower motor the set screw must be aligned and tightened with the motor shaft as shown in figure 11.

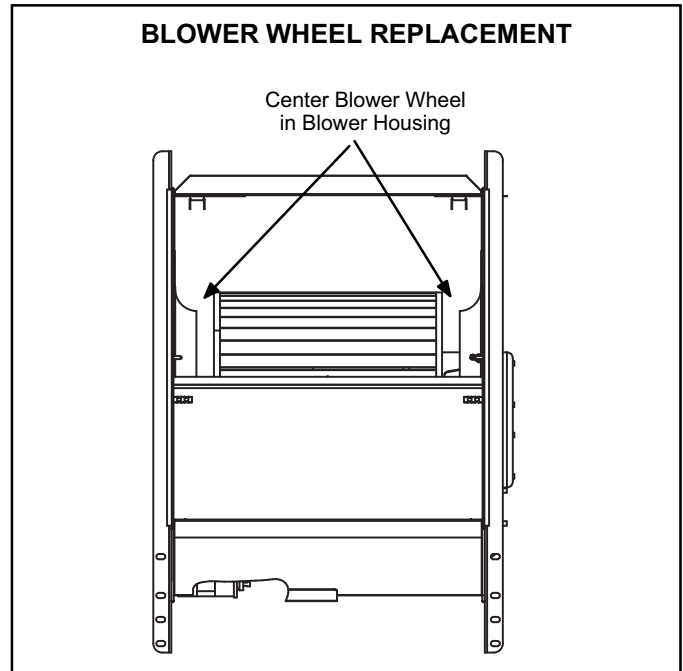

FIGURE 10

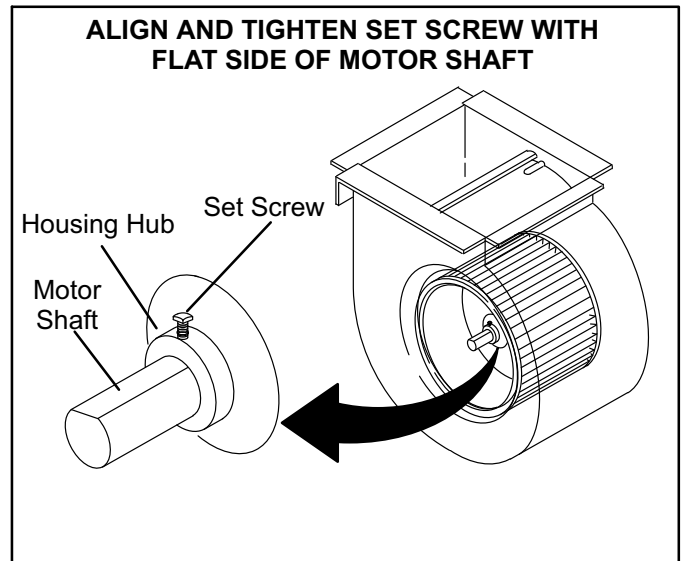
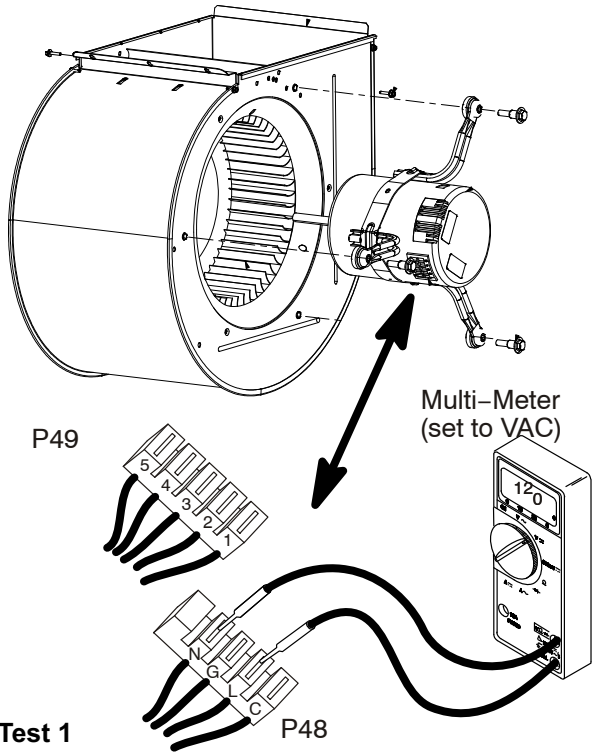
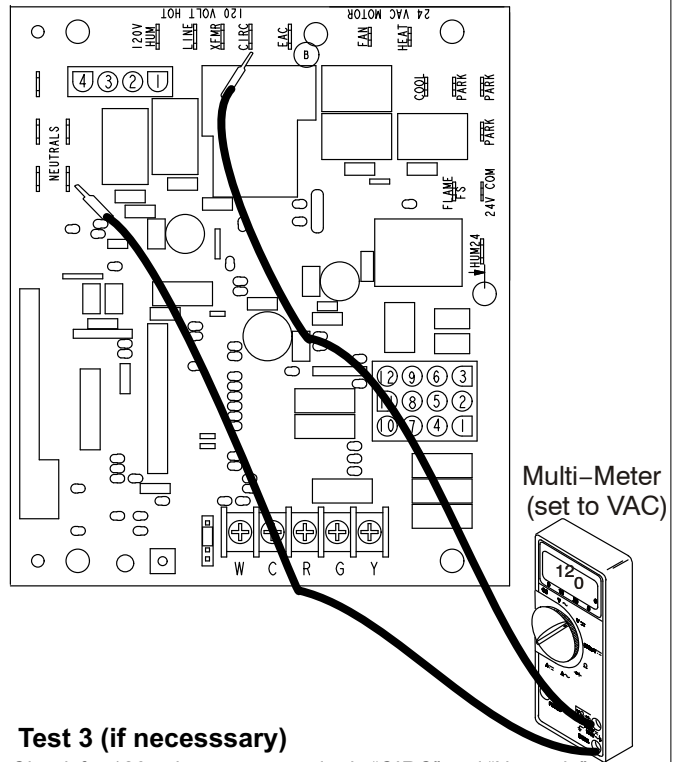

FIGURE 11



Test 1

Turn on power to unit. Check for 120 volts across terminals "L" and "N" on input plug P48. If voltage is present continue to test 2. If voltage is not present problem may be up-stream of plug P48 and proceed to test 3.



Test 3 (if necessary)

Check for 120 volts across terminals "CIRC" and "Neutrals" on the integrated control. If voltage is present, problem is with the harness. If voltage is not present problem may be with the integrated control.

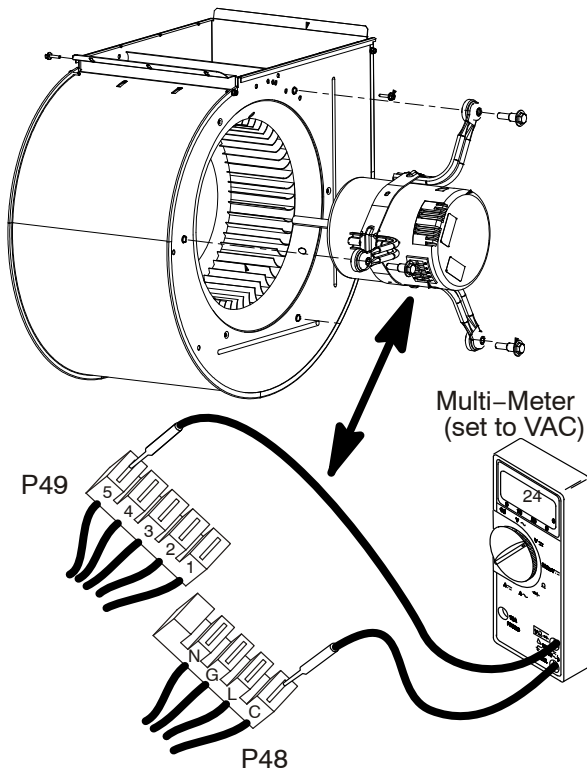

Test 2

Switch thermostat to CONTINUOUS FAN MODE. Check for 24 volts across terminal "C" on input plug P48 and speed tap used for continuous fan. (1, 2, 3, 4 or 5) on input plug P49. If 24 volts is not present problem may be up stream of plug P49. Proceed to test 4.

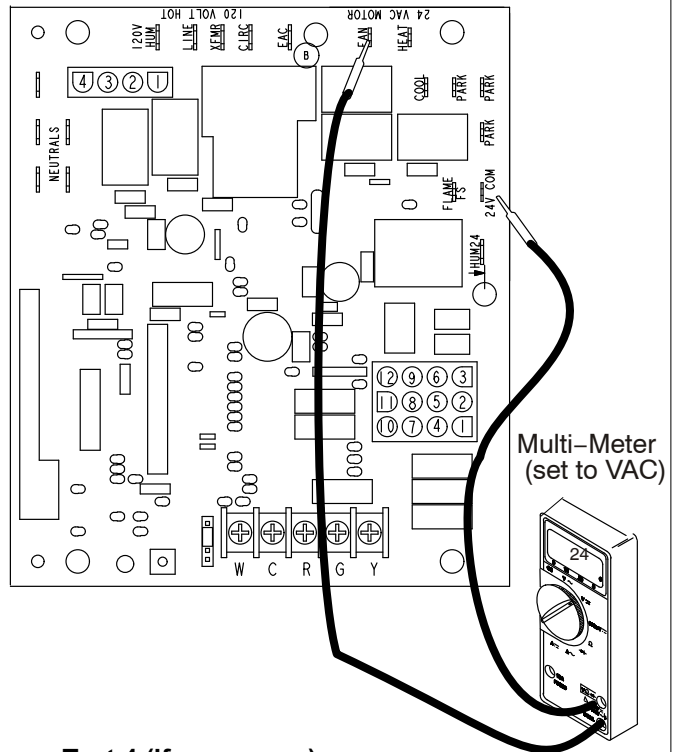

Test 4 (if necessary)

Check for 24 volts across terminals "24 COM" and "FAN" terminals on the integrated control. If voltage is present, problem is with the harness. If voltage is not present problem may be with the integrated control.

FIGURE 12

Replacing the Motor Module

1. Disconnect electrical power to unit.
2. Remove unit access panel.
3. Unplug the **two** harnesses from the motor control module. See figure 13.

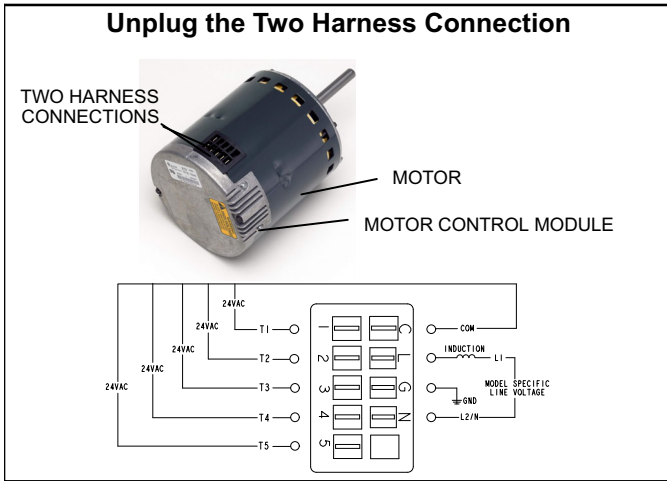

4. Remove the two hex head bolts securing the motor control module to the motor (see figure 14).



5. Slide the motor control module away from the motor to access and disconnect the internal three wire connector. It is not necessary to remove blower motor itself. Set both hex head bolts aside.

Testing the Motor (Figure15)

If any motor fails the below tests, do not install the new control module. The motor is defective and it also must be replaced. The new control can fail if placed on a defective motor.

1. Using an ohmmeter check the resistance from any one of the motor connector pins to the aluminum end plate of the motor. This resistance should be greater than 100k ohms.
2. Check the resistances between each of the three motor connector pins. These should all read approximately the same resistance within an ohm.
3. Check to see if the blower wheel spins freely.



FIGURE 15

TABLE 8

Scale	Measurement range in words	ohms
2 M	two megohm-two million ohms	0 - 2,000,000
200 K	two hundred kilo-ohm-two hundred thousand ohms	0 - 200,000
20 K	twenty kilo-ohm-twenty thousand ohms	0 - 20,000
2 K	two kilo-ohm two-thousand ohms	0 - 2,000
200	two hundred ohms	0 - 200

Motor Module Installation

All replacement motor control modules look similar; however, each module is designed for a specific motor size. It is very important to make sure that you are using the correct replacement motor control module. **USE OF THE WRONG MOTOR CONTROL MODULE MAY RESULT IN UNEXPECTED UNIT OPERATION.**

1. Verify electrical power to unit is disconnected.
2. Connect three-wire harness from motor to control module.
3. Mount new motor control module to motor using two hex head bolts removed in figure 14. Torque bolts to 22 inch pounds or 1/16th clock turn as exemplated to the right.
4. Reconnect the **two** harnesses to the motor control module.
5. The electrical connectors of the motor should be facing down to form a drip loop (figure16). This will direct moisture away from the motor and its electric connections on the motor.

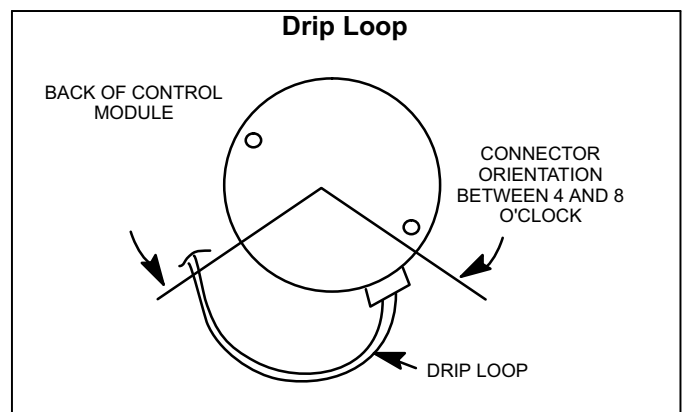
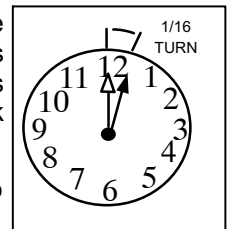

FIGURE 16

II- PLACEMENT AND INSTALLATION

Make sure unit is installed in accordance with installation instructions and applicable codes.

III- START-UP

A- Heating Start-Up

⚠ WARNING

Shock and burn hazard.

EL180UHNE units are equipped with a hot surface ignition system. Do not attempt to light manually.

Gas Valve Operation

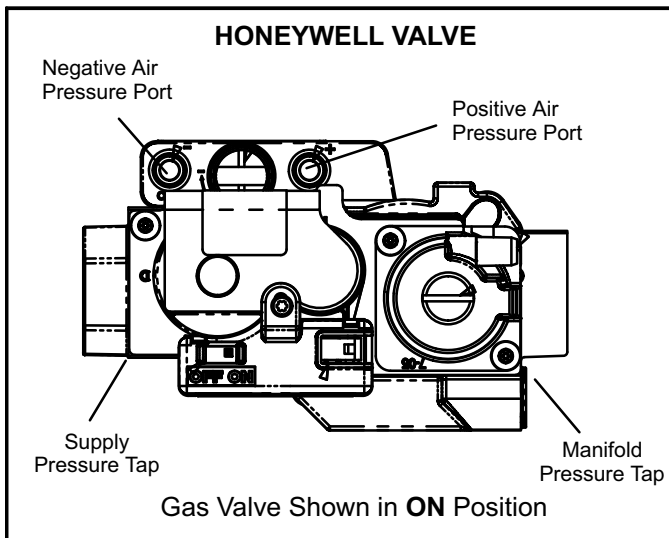

FIGURE 17

- 1 - **STOP!** Read the safety information at the beginning of this section.
- 2 - Set the thermostat to the lowest setting.
- 3 - Turn off all electrical power to the unit.
- 4 - This furnace is equipped with an ignition device which automatically lights the burners. Do **not** try to light the burners by hand.
- 5 - Remove the upper access panel.
- 6 - Move gas valve switch to **OFF position**. Do not force. See figure 17.
- 7 - Wait five minutes to clear out any gas. If you then smell gas, **STOP!** Immediately call your gas supplier from a neighbor's phone. Follow the gas supplier's instructions. If you do not smell gas go to next step.
- 8 - Move gas valve switch to **ON position**. Do not force. See figure 17.
- 9 - Replace the upper access panel.
- 10 - Turn on all electrical power to to the unit.
- 11 - Set the thermostat to desired setting.

NOTE - When unit is initially started, steps 1 through 11 may need to be repeated to purge air from gas line.

- 12 - If the appliance will not operate, follow the instructions "Turning Off Gas to Unit" and call the gas supplier.

Turning Off Gas to Unit

- 1 - Set the thermostat to the lowest setting.
- 2 - Turn off all electrical power to the unit if service is to be performed.
- 3 - Remove the upper access panel.
- 4 - Move gas valve switch to **OFF position**. Do not force. See figure 17.
- 5 - Replace the upper access panel.

B- Safety or Emergency Shutdown

Disconnect main power to unit. Close manual and main gas valves.

C- Extended Period Shutdown

Turn off thermostat or set to "UNOCCUPIED" mode. Close all gas valves (both internal and external to unit) to guarantee no gas leaks into combustion chamber. Turn off power to unit. All access panels and covers must be in place and secured.

IV-HEATING SYSTEM SERVICE CHECKS

A- C.S.A. Certification

All units are C.S.A. design certified without modifications. Refer to the EL180UHNE Installation Instruction.

B- Gas Piping

Gas supply piping should not allow more than 0.5"W.C. drop in pressure between gas meter and unit. Supply gas pipe must not be smaller than unit gas connection.

Compounds used on gas piping threaded joints should be resistant to action of liquefied petroleum gases.

C- Testing Gas Piping

⚠ CAUTION

If a flexible gas connector is required or allowed by the authority that has jurisdiction, black iron pipe shall be installed at the gas valve and extend outside the furnace cabinet.

⚠ IMPORTANT

In case emergency shutdown is required, turn off the main shut-off valve and disconnect the main power to unit. These controls should be properly labeled by the installer.

⚠ WARNING

Do not over torque (800 in-lbs) or under torque (350 in-lbs) when attaching the gas piping to the gas valve.

When pressure testing gas lines, the gas valve must be disconnected and isolated. Gas valves can be damaged if subjected to more than 0.5psig (14" W.C.). See figure 18. If the pressure is equal to or less than 0.5psig (14"W.C.), close the manual shut-off valve before pressure testing to isolate furnace from gas supply.

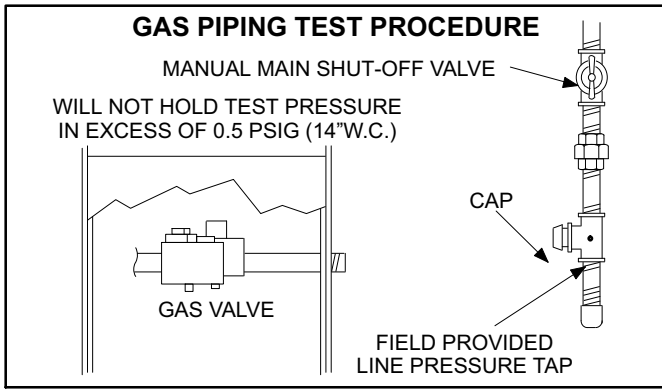

FIGURE 18

When checking piping connections for gas leaks, use preferred means. Kitchen detergents can cause harmful corrosion on various metals used in gas piping. Use of a specialty Gas Leak Detector is strongly recommended. It is available through Lennox under part number 31B2001. See Corp. 8411-L10, for further details.

Do not use matches, candles, flame or any other source of ignition to check for gas leaks.

D- Gas Pressure Adjustment
Gas Flow (Approximate)

TABLE 9

GAS METER CLOCKING CHART				
EL180UHNE Unit	Seconds for One Revolution			
	Natural		LP / Propane	
	1 cu ft Dial	2 cu ft Dial	1 cu ft Dial	2 cu ft Dial
-040	90	180	N/A	N/A
-060	60	120	150	300
-080	45	90	112	224
-100	36	72	N/A	
Natural-1000 btu/cu ft LP /Propane - 2500 btuh/cu ft				

Furnace should operate at least 5 minutes before checking gas flow. Determine time in seconds for **two** revolutions of gas through the meter. (Two revolutions assures a more accurate time.) **Divide by two** and compare to time in table 9. If manifold pressure matches table 10 and rate is incorrect, check gas orifices for proper size and restriction. Remove temporary gas meter if installed.

NOTE - To obtain accurate reading, shut off all other gas appliances connected to meter.

E- Supply and Manifold Pressure
Supply Pressure Measurement

A port on the inlet side of the gas valve provides access to the supply pressure tap. See figure 16. Loosen the screw

and connect a manometer to measure supply pressure. See table 10 for supply line pressure. Tighten screw after measurements have been taken.

Manifold Pressure Measurement

To correctly measure manifold pressure, follow the steps below.

- 1 - Remove the threaded plug from the outlet side of the gas valve and install a field-provided barbed fitting. Connect measuring device "+" connection to barbed fitting to measure manifold pressure.
- 2 - Start unit and allow 5 minutes for unit to reach steady state.
- 3 - After allowing unit to stabilize for 5 minutes, record manifold pressure and compare to value given in Table 10. Make manifold adjustment if necessary.
- 4 - Shut unit off and remove manometer as soon as an accurate reading has been obtained.
- 5 - Start unit and perform leak check. Seal leaks if found.

TABLE 10
Supply Line and Manifold Pressure

Honeywell Gas Valve				
	Natural		LP/Propane	
	Manifold	Supply	Manifold	Supply
040	1.6 - 2.2	4.5 - 13.0	N/A	N/A
060, 080	3.0 - 3.8		3.4 - 3.8	11.0 - 13.0
100	3.0 - 3.8	4.5 - 13.0	N/A	N/A

▲ IMPORTANT

For safety, shut unit off and remove manometer as soon as an accurate reading has been obtained. Take care to replace pressure tap plug.

F- Proper Combustion

Furnace should operate a minimum 15 minutes with correct manifold pressure and gas flow rate before checking combustion. Take combustion sample beyond the flue outlet and compare to the tables below. The maximum carbon monoxide reading should not exceed 100 ppm.

TABLE 11

EL180UHNE Unit	CO ₂ % For Nat	CO ₂ % For LP
040	6.5 - 7.5	N/A
060		7.5 - 9.0
080		7.5 - 9.0
100		N/A
The maximum carbon monoxide reading is 100 ppm.		

G- High Altitude

Units are **NOT** approved for installations over 4500 ft

H- Proper Ground and Voltage

A poorly grounded furnace can contribute to poor flame sense signal. Use the following procedure to check for ground and voltage to the integrated control.

- 1 - Measure the AC voltage between Line Neutral (spade terminals) and "C" terminal (low voltage terminal block) on the integrated control. See figure 19. A wide variation in the voltage between Line Neutral and "C" as a function of load indicates a poor or partial ground. Compare the readings to the table below. If the readings exceed the maximum shown in table 12, make repairs before operating the furnace.
- 2 - In addition, measure the AC voltage from Line Hot to Line Neutral (spade terminals) on the integrated control. See figure 20. This voltage should be in the range of 97 to 132 Vac

TABLE 12

Furnace Status	Measurement VAC	
	Expected	Maximum
Power On Furnace Idle	0.3	2
CAI / Ignitor Energized	0.75	5
Indoor Blower Energized	Less than 2	10

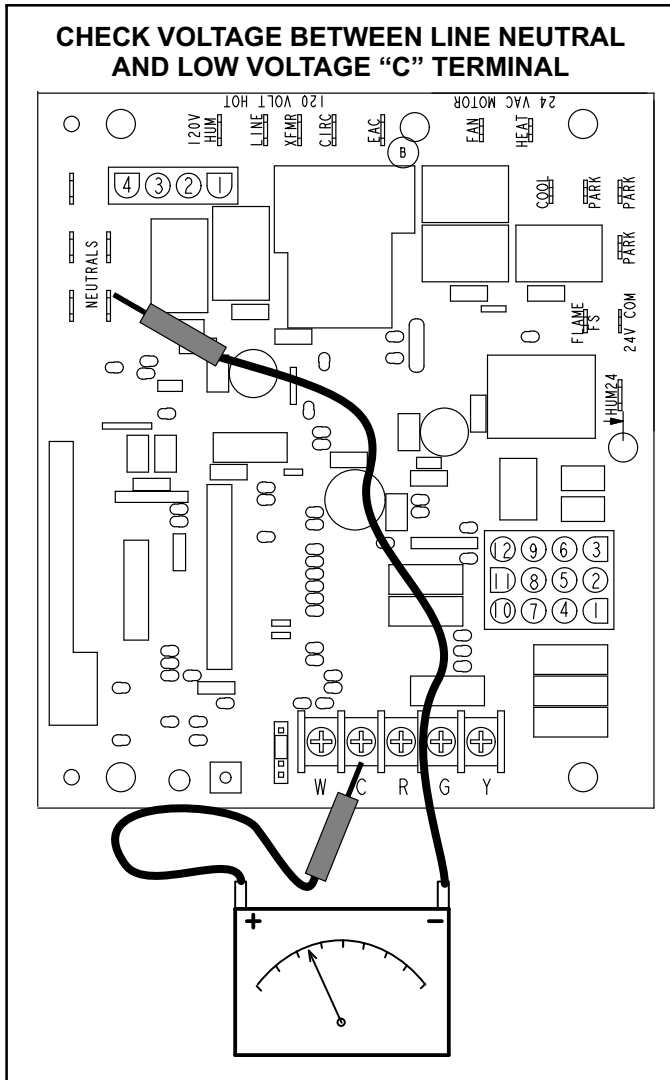

FIGURE 19

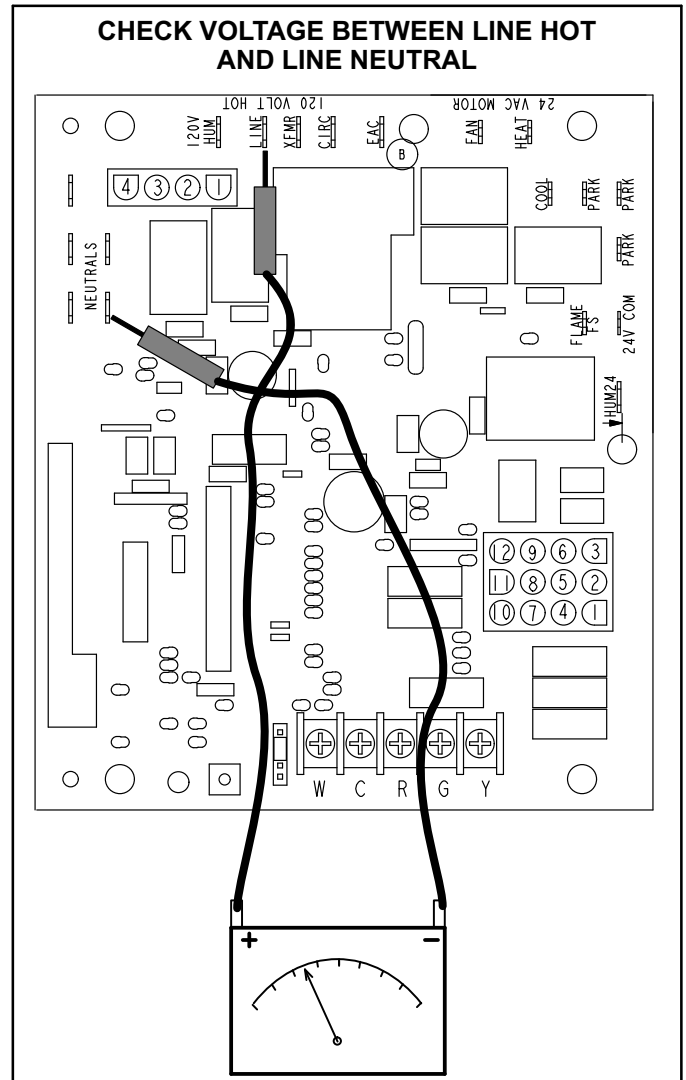

FIGURE 20

V-TYPICAL OPERATING CHARACTERISTICS

A-Blower Operation and Adjustment

NOTE- The following is a generalized procedure and does not apply to all thermostat controls.

- 1 - Blower operation is dependent on thermostat control system.
- 2 - Generally, blower operation is set at thermostat sub-base fan switch. With fan switch in ON position, blower operates continuously. With fan switch in AUTO position, blower cycles with demand or runs continuously while heating or cooling circuit cycles.
- 3 - Depending on the type of indoor thermostat, blower and entire unit will be off when the system switch is in OFF position.

B-Temperature Rise (Figure 21)

Temperature rise for EL180UHNE units depends on unit input, blower speed, blower horsepower and static pressure as marked on the unit rating plate. The blower speed must be set for unit operation within the range of "TEMP. RISE °F" listed on the unit rating plate.

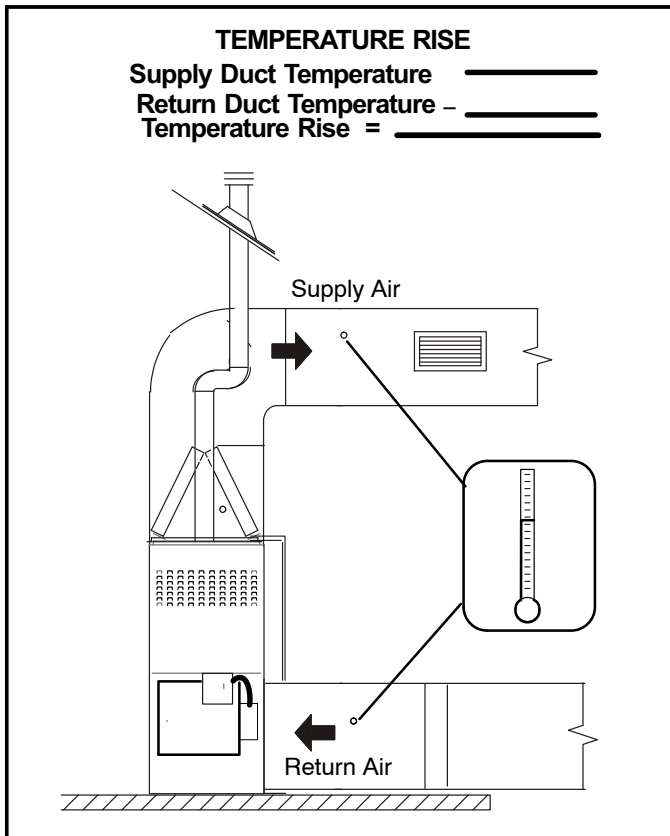

FIGURE 21

C-External Static Pressure

- 1 - Tap locations shown in figure 22 .
- 2 - Punch a 1/4" diameter hole in supply and return air plenums. Insert manometer hose flush with inside edge of hole or insulation. Seal around the hose with permagum. Connect the zero end of the manometer to the discharge (supply) side of the system. On ducted systems, connect the other end of manometer to the return duct as above.
- 3 - With only the blower motor running and the evaporator coil dry, observe the manometer reading. Adjust blower motor speed to deliver the air desired according to the job requirements. For heating speed external static pressure drop must not be more than 0.5" W.C. For cooling speed external static pressure drop must not be more than 0.8" W.C.
- 4 - Seal the hole when the check is complete.

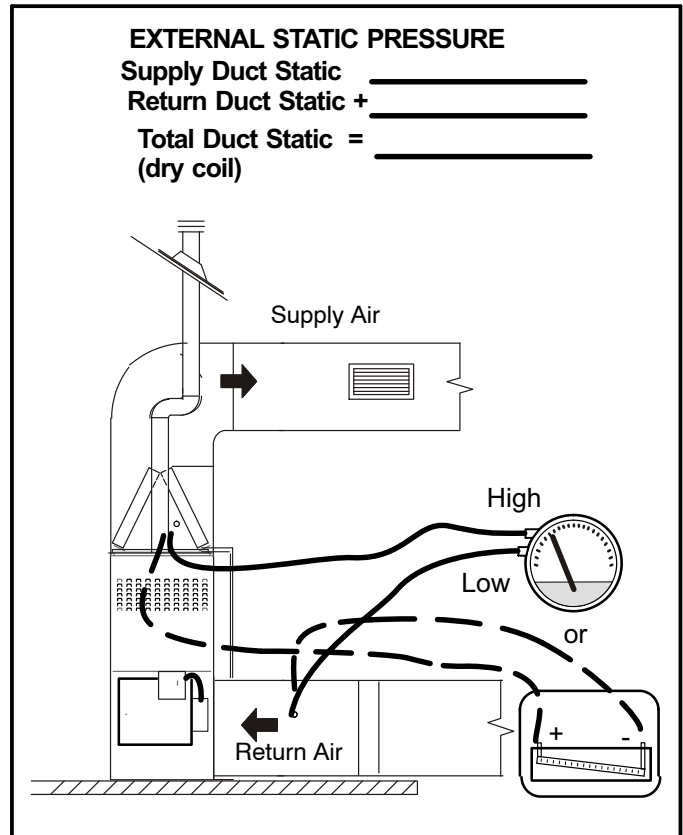

FIGURE 22

D-Blower Speed Taps

Blower speed tap changes are made on the integrated control. See figure 3. The heating tap is connected to the "HEAT" terminal and the cooling tap is connected to the "COOL" terminal. The continuous blower tap is connected to the "FAN" terminal. Unused taps must be secured on dummy terminals labeled "PARK". To change out existing speed tap, turn off power and switch out speed tap with tap connected to "PARK". See blower speed tap table on unit diagram for motor tap colors for each speed.

VI-MAINTENANCE

At the beginning of each heating season, and to comply with the **Lennox Limited Warranty**, your system should be checked by a licensed professional technician (or equivalent) as follows:

NOTE - Burner inspection and service is not recommended for annual furnace maintenance.

IMPORTANT

If a high-efficiency filter is being installed as part of this system to ensure better indoor air quality, the filter must be properly sized. High-efficiency filters have a higher static pressure drop than standard-efficiency glass/foam filters. If the pressure drop is too great, system capacity and performance may be reduced. The pressure drop may also cause the limit to trip more frequently during the winter and the indoor coil to freeze in the summer, resulting in an increase in the number of service calls.

Before using any filter with this system, check the specifications provided by the filter manufacturer against the data given in the appropriate Lennox Product Specifications bulletin. Additional information is provided in Service and Application Note ACC-00-2 (August 2000).

WARNING

Fire Hazard. Use of aluminum wire with this product may result in a fire, causing property damage, severe injury or death. Use copper wire only with this product.

CAUTION

Failure to use properly sized wiring and circuit breaker may result in property damage. Size wiring and circuit breaker(s) per Product Specifications bulletin (EHB) and unit rating plate.

- 1- Check wiring for loose connections, voltage at indoor unit and amperage of indoor motor.
- 2- Inspect all gas pipe and connections for leaks.
- 3- Check the cleanliness of filters and change if necessary (monthly).
- 4- Check the cleanliness of blower assembly and clean the housing, blower wheel and blower motor if necessary.
- 5- Inspect the combustion air inducer and clean if necessary.

TABLE 13

Furnace Cabinet Width	Filter Size	
	Side Return	Bottom Return
A - 14-1/2"	16 X 25 X 1 (1)	14 X 25 X 1 (1)
B - 17-1/2"	16 X 25 X 1 (1)	16 X 25 X 1 (1)
C - 21"	16 X 25 X 1 (1)	20 X 25 X 1 (1)

- 6- Evaluate the heat exchanger integrity by inspecting the heat exchanger per the AHRI heat exchanger inspection procedure. This procedure can be viewed at www.ahrinet.org. See "Induced-draft Furnace Heat Exchanger Inspection Procedure".
 - 7- Ensure sufficient combustion air is available to the furnace. Fresh air grilles and louvers (on the unit and in the room where the furnace is installed) must be properly sized, open and unobstructed to provide combustion air.
 - 8- Inspect the furnace venting system to make sure it is in place, structurally sound, and without holes, corrosion, or blockage. Vent system must be free and clear of obstructions and must slope upward away from the furnace. Vent system should be installed per the National Fuel Gas Code
 - 9- Inspect the furnace return air duct connection to ensure the duct is sealed to the furnace. Check for air leaks on supply and return ducts and seal where necessary.
 - 10- Check the condition of the furnace cabinet insulation and repair if necessary.
 - 11- Perform a complete combustion analysis during the furnace inspection to ensure proper combustion and operation. Consult Service Literature for proper combustion values.
 - 12- Verify operation of smoke detectors and CO detectors and replace batteries as required.
- Perform a general system test. Turn on the furnace to check operating functions such as the start-up and shut-off operation.
- 1 - Check the operation of the ignition system, inspect and clean flame sensor. Check microamps before and after. Check controls and safety devices (gas valve, flame sensor, temperature limits). Consult Service Manual for proper operating range. Thermal Limits should be checked by restricting airflow and not disconnecting the indoor blower. For additional details, please see Service and Application Note H-04-9.
 - 2 - Verify that system total static pressure and airflow settings are within specific operating parameters.
 - 3 - Clock gas meter to ensure that the unit is operating at the specified firing rate. Check the supply pressure and the manifold pressure. **Not all gas valves are adjustable.** Verify correct temperature rise.

Cleaning the Heat Exchanger and Burners

NOTE - Use papers or protective covering in front of the furnace during cleaning.

- 1 - Turn off both electrical and gas power supplies to furnace.
- 2 - Remove flue pipe and top cap (*some applications top cap can remain*) from the unit.
- 3 - Label the wires from gas valve, thermal switch, primary limit switch and make-up box then disconnect them.
- 4 - Remove the screws that secure the combustion air inducer to the collector box.
- 5 - Disconnect gas supply piping. Remove the screw securing the air fuel plenum and remove along with the air intake assembly as one component.
- 6 - Remove screws from both sides, top and bottom of vestibule panel.
- 7- Remove heat exchanger. It may be necessary to spread cabinet side to allow more room. If so, remove five screws from the left side or right side of cabinet. See figure 24.
- 8- Back wash using steam. Begin from the burner opening on each tube. Steam must not exceed 275°F.
- 9- To clean burner, remove from the air gas plenum and run a vacuum cleaner over the face of burner. Visually inspect inside the burner for any blockage caused by foreign matter. Remove any blockage. Figure 23 shows burner detail. Replace gasket between burner plate and air fuel plenum then re-install burner plate.
- 10- To clean the combustion air inducer visually inspect and using a wire brush clean where necessary. Use compressed air to clean off debris and any rust.
- 11- Reinstall heat exchanger in vestibule. (Replace the five screws in the cabinet from step 10 if removed).
- 12- Reinstall the air fuel plenum and air intake assembly. Re-install the combustion air inducer assembly. Make note to re-install all screws. Failure to replace all screws may cause leaks.
- 13- Reconnect all wires.
- 14- Reconnect top cap and vent pipe to combustion air inducer outlet.
- 15- Reconnect gas supply piping.
- 16- Turn on power and gas supply to unit.
- 17- Set thermostat and check for proper operation.
- 18- Check all piping connections, factory and field, for gas leaks. Use a leak detecting solution or other preferred means.
- 19- If a leak is detected, shut gas and electricity off and repair leak.
- 20- Repeat steps 24 and 26 until no leaks are detected.
- 21- Replace access panel.

CAUTION

Some soaps used for leak detection are corrosive to certain metals. Carefully rinse piping thoroughly after leak test has been completed. Do not use matches, candles, flame or other sources of ignition to check for gas leaks.

**BURNER, C.A.I ASSEMBLY &
HEAT EXCHANGER REMOVAL**

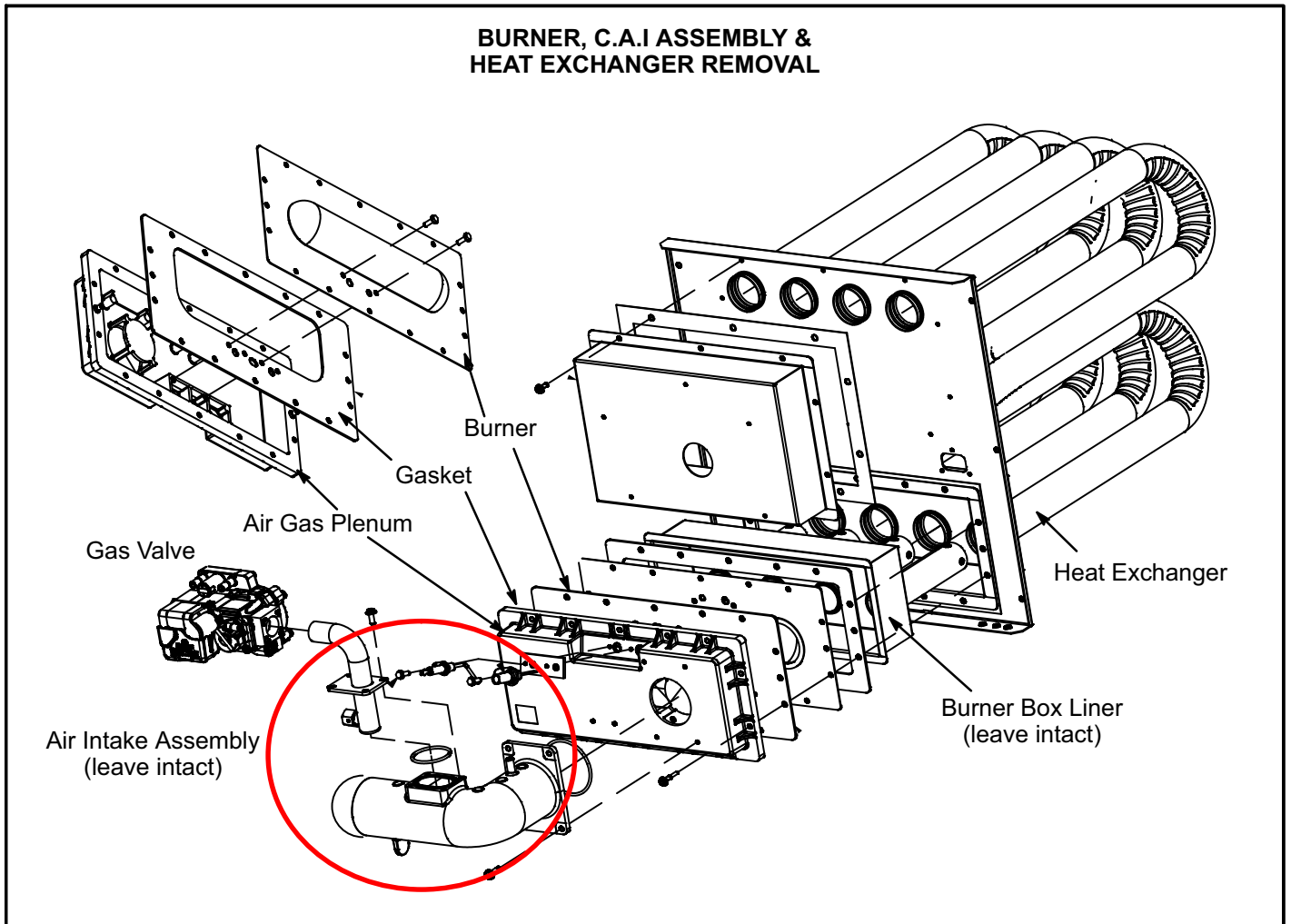

FIGURE 23

**Remove 5 screws if necessary
(either side of cabinet)**

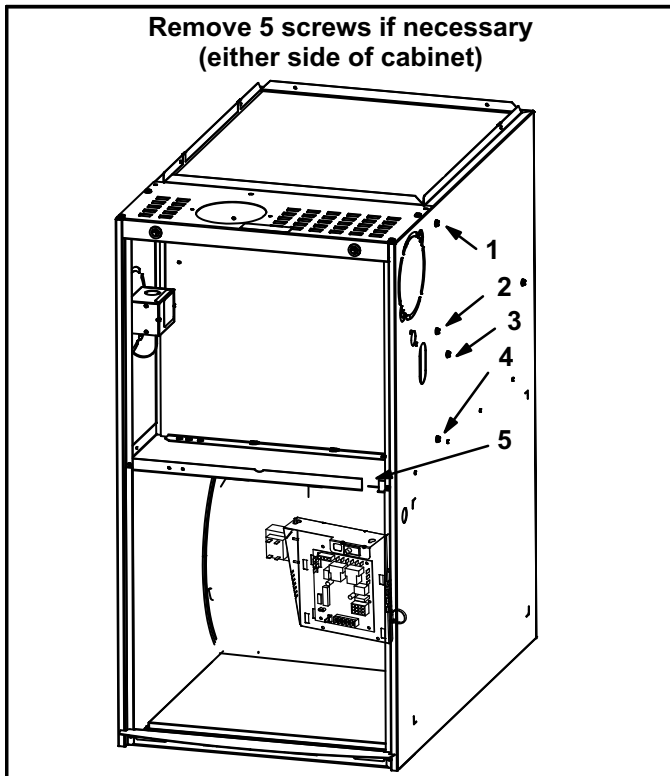
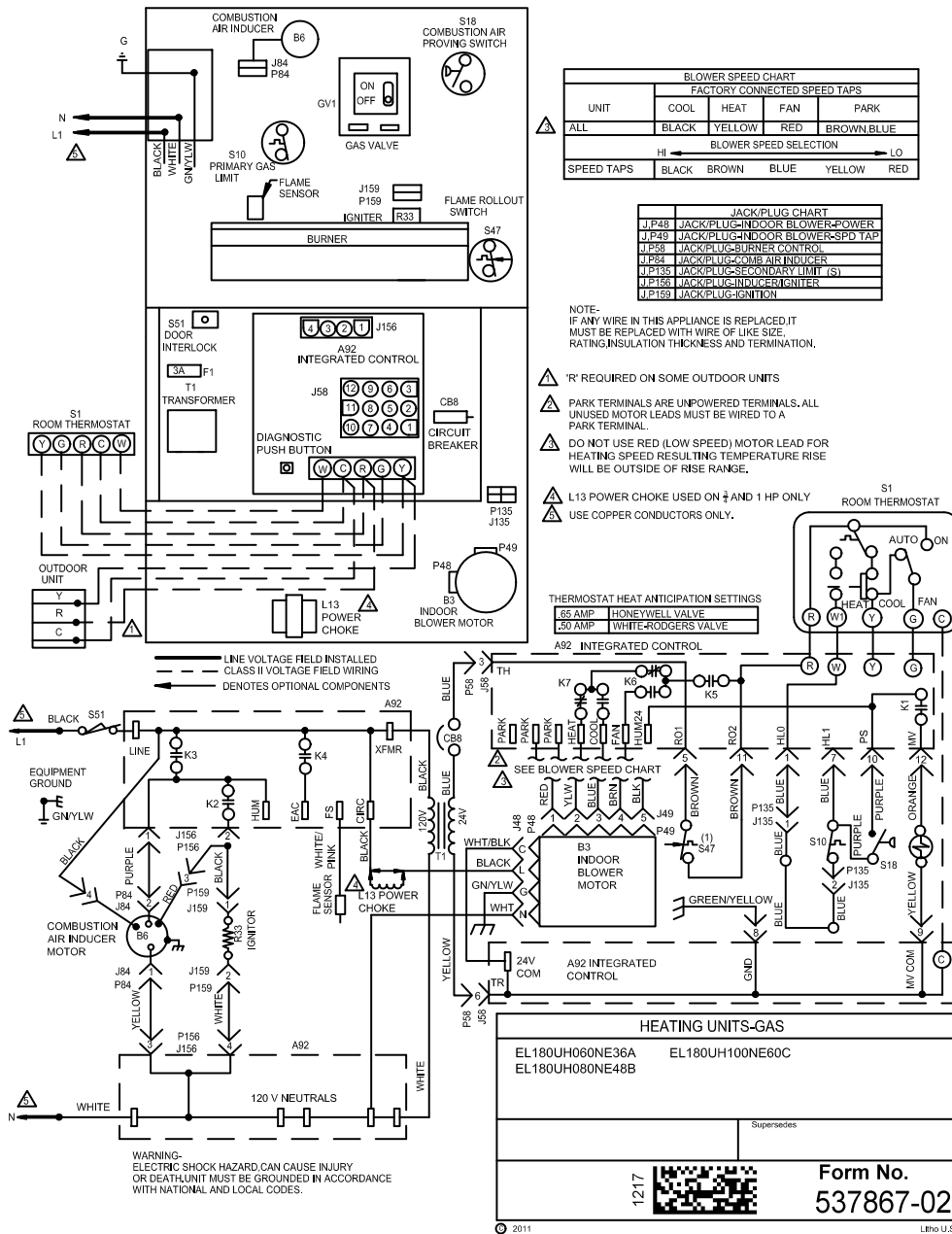

FIGURE 24

VII- Wiring and Sequence of Operation

EL180UHNE060/080/100 Schematic



- Line voltage is applied to L1 and N. the T1 low voltage transformer is energized, and line voltage is applied to B3 indoor blower.
- S47 rollout switch(es) must be closed in order for 24V from transformer to be output on integrated control "R" to power thermostat.
- When there is a call for heat, W1 of the thermostat energizes W of the furnace control with 24VAC.
- A92 integrated control runs a self-check. S10 primary limit and S21 secondary limit contacts are found to be closed. Call for heat can continue.
- A92 integrated control energizes B6 combustion air inducer. S18 combustion air pressure switch closes. Once S18 closes, a 15-second pre-purge follows.
- A92 integrated control energizes R33 ignitor. A 20-second warm-up period begins.
- GV1 gas valve opens for a 4-second trial for ignition
- Flame is sensed, gas valve remains open for the heat call.
- After 30-second delay (from flame sensed), A92 integrated control applies 24VAC to Heat speed of B3 indoor blower.
- When heat demand is satisfied, W1 of the indoor thermostat de-energizes W of A92 ignition control which de-energizes GV1 gas valve. B6 combustion air inducer continues a 5-second post-purge period, and B3 indoor blower completes a selected OFF time delay.

EL180UHNE040 Schematic

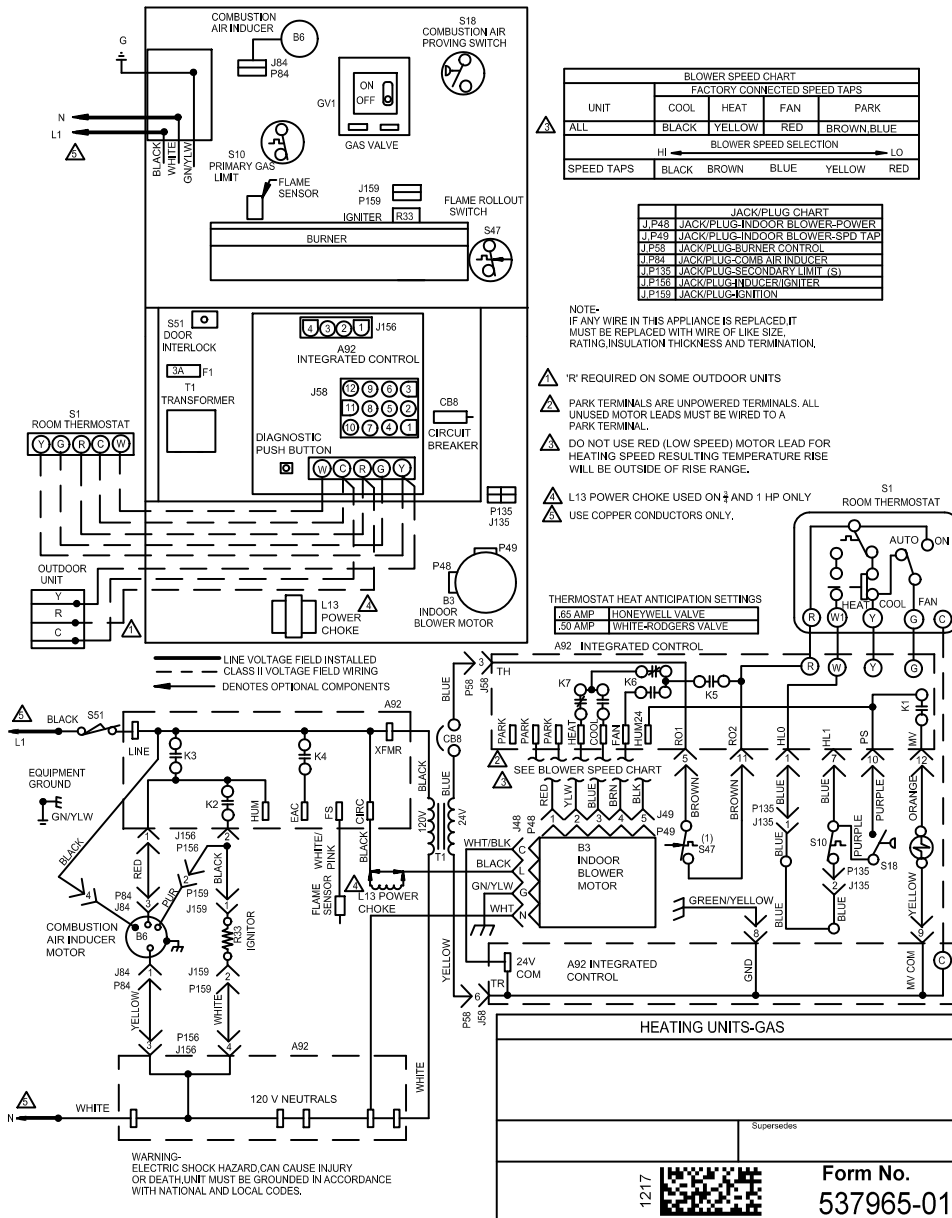

- Line voltage is applied to L1 and N. the T1 low voltage transformer is energized, and line voltage is applied to B3 indoor blower.
- S47 rollout switch(es) must be closed in order for 24V from transformer to be output on integrated control "R" to power thermostat.
- When there is a call for heat, W1 of the thermostat energizes W of the furnace control with 24VAC.
- A92 integrated control runs a self-check. S10 primary limit and S21 secondary limit contacts are found to be closed. Call for heat can continue.
- A92 integrated control energizes B6 combustion air inducer. S18 combustion air pressure switch closes. Once S18 closes, a 15-second pre-purge follows.
- A92 integrated control energizes R33 ignitor. A 20-second warm-up period begins.
- GV1 gas valve opens for a 4-second trial for ignition
- Flame is sensed, gas valve remains open for the heat call.
- After 30-second delay (from flame sensed), A92 integrated control applies 24VAC to Heat speed of B3 indoor blower.
- When heat demand is satisfied, W1 of the indoor thermostat de-energizes W of A92 ignition control which de-energizes GV1 gas valve. B6 combustion air inducer continues a 5-second post-purge period, and B3 indoor blower completes a selected OFF time delay.

HEATING SEQUENCE OF OPERATION

NORMAL HEATING MODE

ABNORMAL HEATING MODE

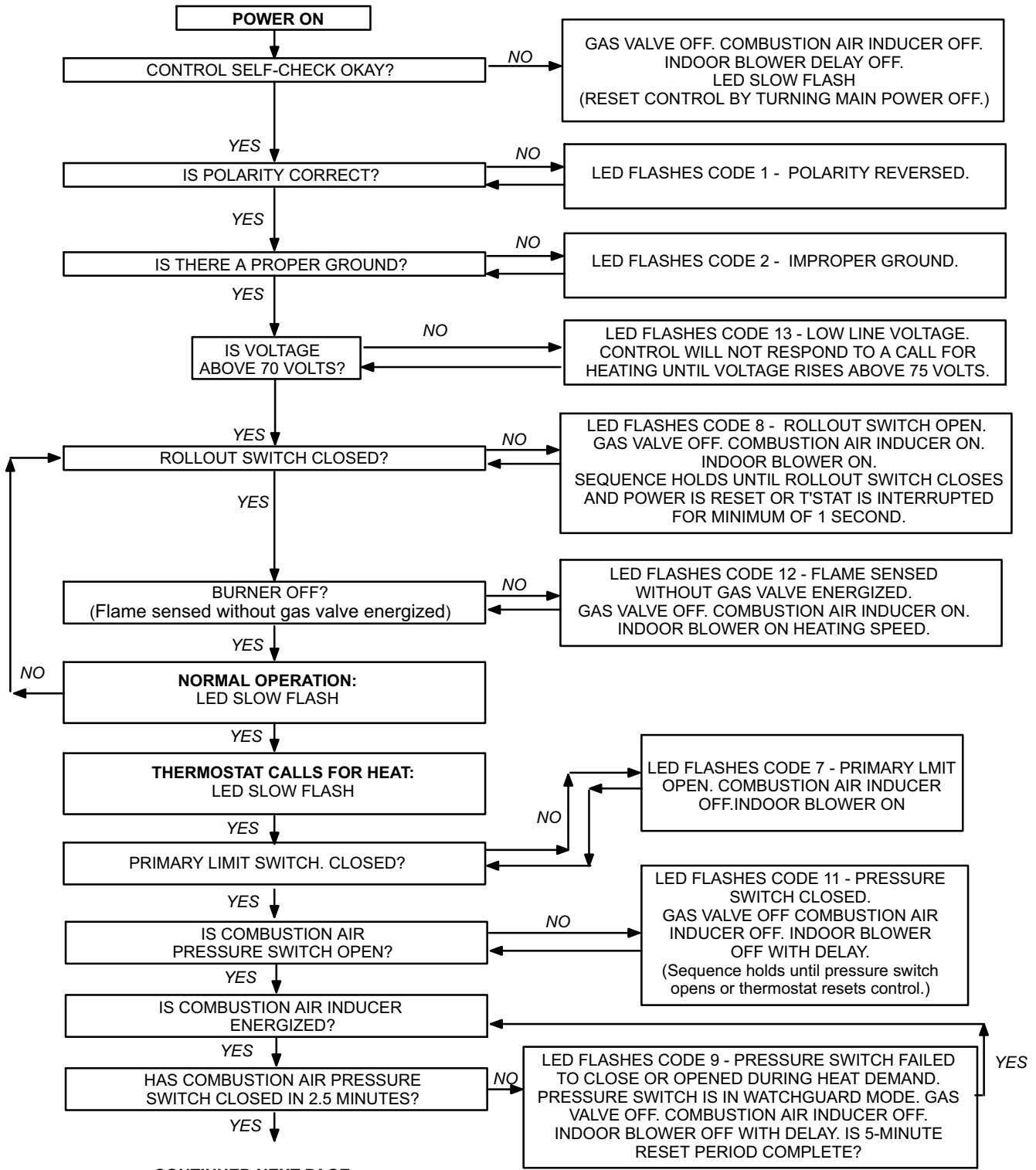

Troubleshooting: Heating Sequence of Operation (Continued)

HEATING SEQUENCE CONTINUED

NORMAL HEATING MODE

ABNORMAL HEATING MODE

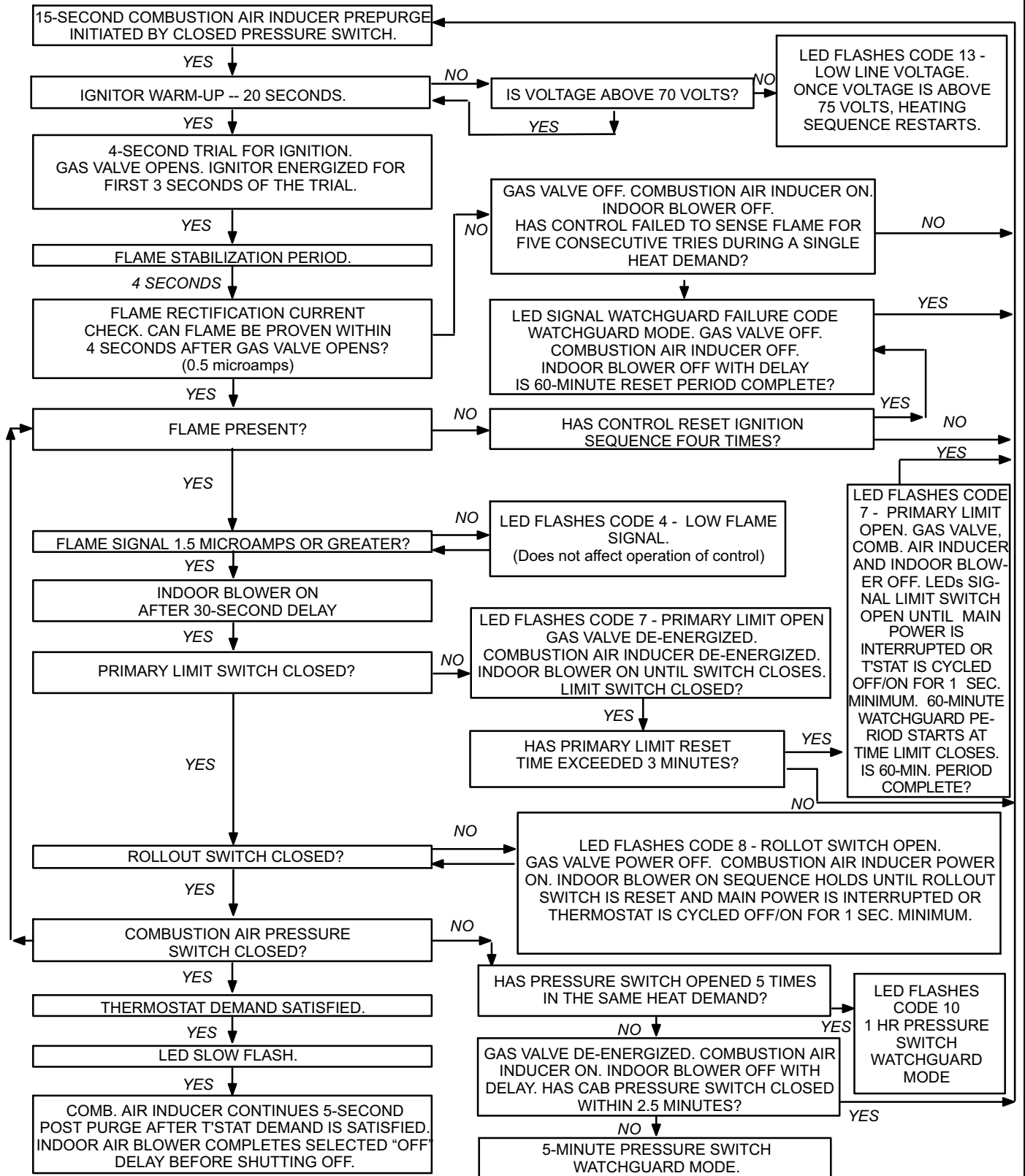

COOLING SEQUENCE OF OPERATION

NORMAL COOLING MODE

ABNORMAL COOLING MODE

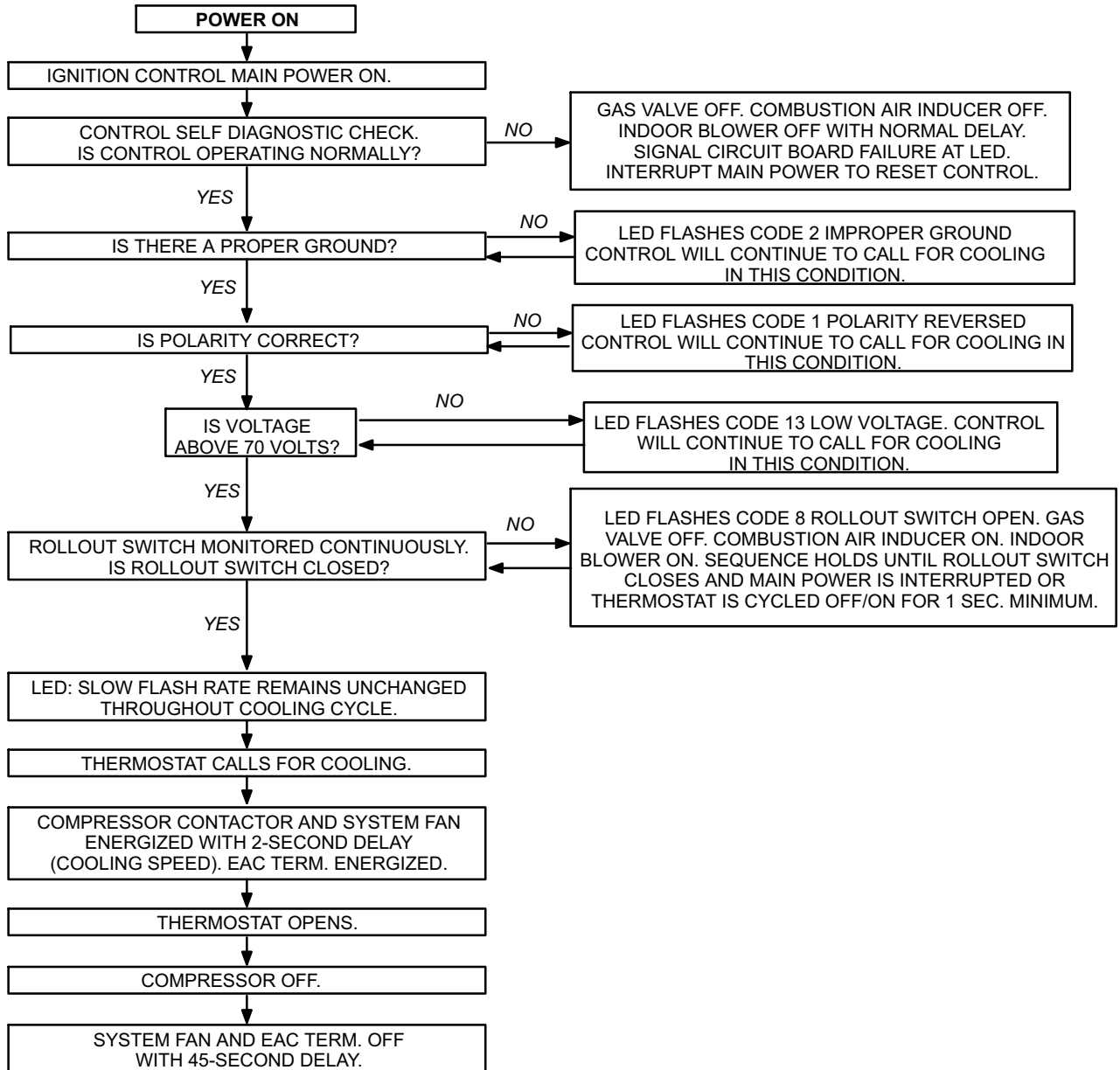

CONTINUOUS FAN SEQUENCE OF OPERATION

