



**PRODUCT LITERATURE**

Lennox Industries Inc.  
Dallas, Texas

APPLICATION  
GUIDE  
FOR USE WITH  
**GCWB95F-150**

**COMBI  
CONDENSING  
GAS BOILER**

This manual has been prepared for use with the appropriate Installation, Operation and Maintenance Manual.

## TABLE OF CONTENTS

<b>Important Safety Information</b> .....	<b>3</b>
<b>Labor Saving Piping Manifold / Near Boiler Piping Connections</b> .. ..	<b>4</b>
<b>General Information - Hydronic Piping</b> .....	<b>5</b>
<b>General Information - Wiring</b> .....	<b>7</b>
<b>Piping And Wiring Diagrams</b>	
Piping Legend .....	8
GCWB9F-150 With Zone Circulator Pumps - Piping Diagram .....	9
GCWB9F-150 With Zone Pumps - Wiring Diagram .....	10
GCWB9F-150 With Zone Pumps .....	11
GCWB9F-150 With Zone Valves - Piping Diagram .....	12
<b>LBuffer Tank - Piping and Wiring Diagram</b> .....	<b>13</b>
<b>Optional Equipment</b> .....	<b>14</b>
Outdoor Air Sensor Data .....	14
<b>Wiring Diagrams</b>	
GCWB9F-150 Floor Standing - Combi Wiring Diagram .....	15
<b>Altitude Effects On Boiler Performance</b> .....	<b>16</b>
<b>Low Water Cutoff Application</b> .....	<b>17</b>
<b>Error Code Table</b> .....	<b>22</b>
<b>Troubleshooting Chart</b> .....	<b>23</b>
<b>Fault Solution Sections</b> .....	<b>25</b>

## IMPORTANT SAFETY INFORMATION

### 1. General

Boiler installation shall be completed by qualified agency. See Installation, Operation & Maintenance Manual for additional information.

#### **WARNING**

Fire, explosion, asphyxiation and electrical shock hazard. Improper installation could result in death or serious injury. Read this manual and understand all requirements before beginning installation.

### 2. Become familiar with symbols identifying potential hazards.



This is the safety alert symbol. Symbol alerts you to potential personal injury hazards. Obey all safety messages following this symbol to avoid possible injury or death.

#### **DANGER**

Indicates a hazardous situation which, if not avoided, WILL result in death or serious injury.

#### **WARNING**

Indicates a hazardous situation which, if not avoided, could result in death or serious injury.

#### **CAUTION**

Indicates a hazardous situation which, if not avoided, could result in minor or moderate injury.

### 3. Installation shall conform to requirements of authority having jurisdiction or in absence of such requirements:

- *United States*
  - National Fuel Gas Code, ANSI Z223.1/NFPA 54.
  - National Electrical Code, NFPA 70.
- *Canada*
  - Natural Gas and Propane Installation Code, CAN/CSA B149.1.
  - Canadian Electrical Code, Part I, Safety Standard for Electrical Installations, CSA C22.1

### 4. Where required by authority having jurisdiction, installation shall conform to Standard for Controls and Safety Devices for Automatically Fired Boilers, ANSI/ASME CSD-1.

Additional manual reset low water cutoff and/or high limit may be required.

### 5. Requirements for Commonwealth of Massachusetts:

Boiler installation must conform to Commonwealth of Massachusetts code 248 CMR which includes but is not limited to:

- Installation by licensed plumber or gas fitter.

# NEAR BOILER PIPING CONNECTIONS

## GCWB95F-150 COMBI

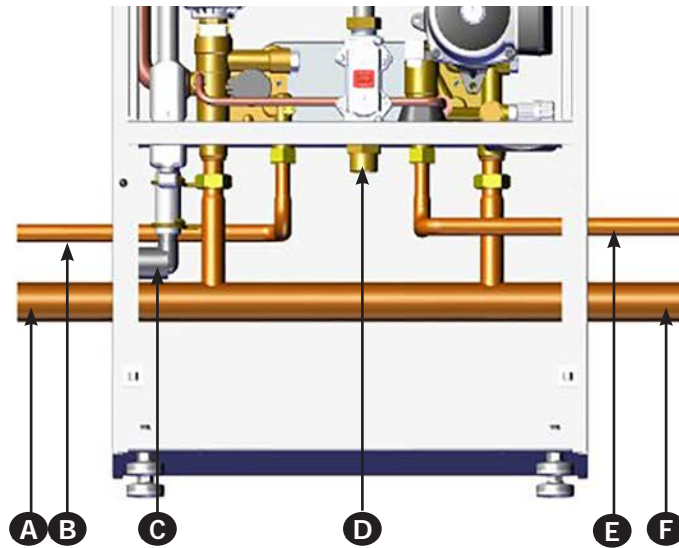

LEGEND		150
A	Heating supply connection	1¼" sweat
B	DHW outlet	1/2" sweat
C	Drain connection for condensate	3/4" NPT
D	Gas shutoff connection	3/4" NPT
E	Cold DHW inlet tap	1/2" sweat
F	Heating return connection	1¼" sweat

**⚠ WARNING**

Burn and scald hazard! Manufacturer requires installation of field supplied anti-scald valve. Failure to follow these instructions could result in death or serious injury.

**General Information:**

Piping installation, materials, and joining methods shall conform to requirements of authority having jurisdiction or in absence of such requirements:

- **USA** - National Fuel Gas Code, ANSI Z223.1/NFPA 54
- **Canada** - Natural Gas and Propane Installation Code, CAN/CSA B149.1

**Manufacturer Requirements/Recommendations:**

- **Manufacturer requires all domestic hot water (DHW) installations use an anti-scald valve.** Local codes may require additional equipment (expansion tank, relief valves, etc.) Select and size equipment to suit installation and meet code requirements.
- Manufacturer recommends use of a water filter on incoming water supply line.
- Manufacturer recommends use of a magnetic dirt separator in the hydronic system where there are cast iron or steel components, or where the previous boiler was a cast iron heat exchanger. The abrasive, extremely fine sediment is difficult to remove and can deposit onto heat exchanger surfaces and accumulate in pump cavities causing reduced efficiency and premature wear.
- The ASME temperature and pressure relief valve and temperature and pressure gauge shall be installed to conform to requirements of the authority having jurisdiction. Refer to appropriate manufacturer instructions for installation requirements.
- If piping manifold is not used, a primary/secondary piping arrangement is manufacturer required. Maximum of 12" separation between supply and return pipe (closely spaced tees) of the boiler shall be maintained.
- Limit combined supply and return pipe lengths to maximum linear lengths of 20 ft (6.1 m) between boiler and closely spaced tees, when minimum 3/4" NPT pipe size is used. Linear length may be increased if supply and return pipe size is increased to limit pressure drop.
- Manufacturer recommends installing a shutoff and purge valve to use during commissioning to ensure the boiler does not shut down due to over temperature. Do not install shutoff between boiler and LWCO.

FOR YOUR SAFETY READ BEFORE OPERATING

⚠ DANGER



**Hot Water Can Scald!**

Water heated to temperature for clothes washing, dish washing and other sanitizing needs can scald and cause permanent injury. Children, elderly, and infirm or physically handicapped persons are more likely to be permanently injured by hot water. Never leave them unattended in bathtub or shower. Never allow small children to use a hot water tap or draw their own bath.

If anyone using hot water in the building fits the above description, or if state laws or local codes require certain water temperatures at hot water taps, you must take special precautions:

- Use lowest possible temperature setting.
- Install some type of tempering device, such as an automatic mixing valve, at hot water tap or water heater. Automatic mixing valve must be selected and installed according to manufacturer's recommendations and instructions.
- Water passing out of drain valves may be extremely hot. To avoid injury:
  - Make sure all connections are tight.
  - Direct water flow away from any person.

## GENERAL INFORMATION - HYDRONIC PIPING

Water Temperature Setting	1st Degree Burn Exposure Time For An Adult	2nd and 3rd Degree Burn Exposure Time For An Adult
120° F	1 minute	5 minutes
130° F	5 seconds	30 seconds
140° F	2 seconds	5 seconds
150° F	1 second	1.5 seconds
160° F	Instantaneous	0.5 seconds

**Note:** Warning for Infants, Children, and Elderly: Great care must be taken when exposing the aforementioned groups to warm or hot water as they can be badly burned in exposure times less than half of the time for an adult.

**Note** → Provided Wiring and Piping illustrations are meant to show system concepts only. Installer is responsible for all equipment required by authority having jurisdiction.

**Note** → Arrange piping to prevent water dripping onto boiler.

## GENERAL INFORMATION - WIRING

### Electrical Wiring Information:

All field wiring shall conform to the authority having jurisdiction or, in the absence of such requirements to:

- **USA:** National Electrical Code, ANSI/NFPA 70,
- **Canada:** Canadian Electrical Code, Part I, CSA C22.1: Safety Standard for Electrical Installations.

Wiring diagrams shown in this manual utilize the ARGO™ Universal Control, and optional use of a H2O Buffer Tank.

**Note**

**DO NOT** use 120 V thermostat terminals (m1- #1 and #2).

**Note**



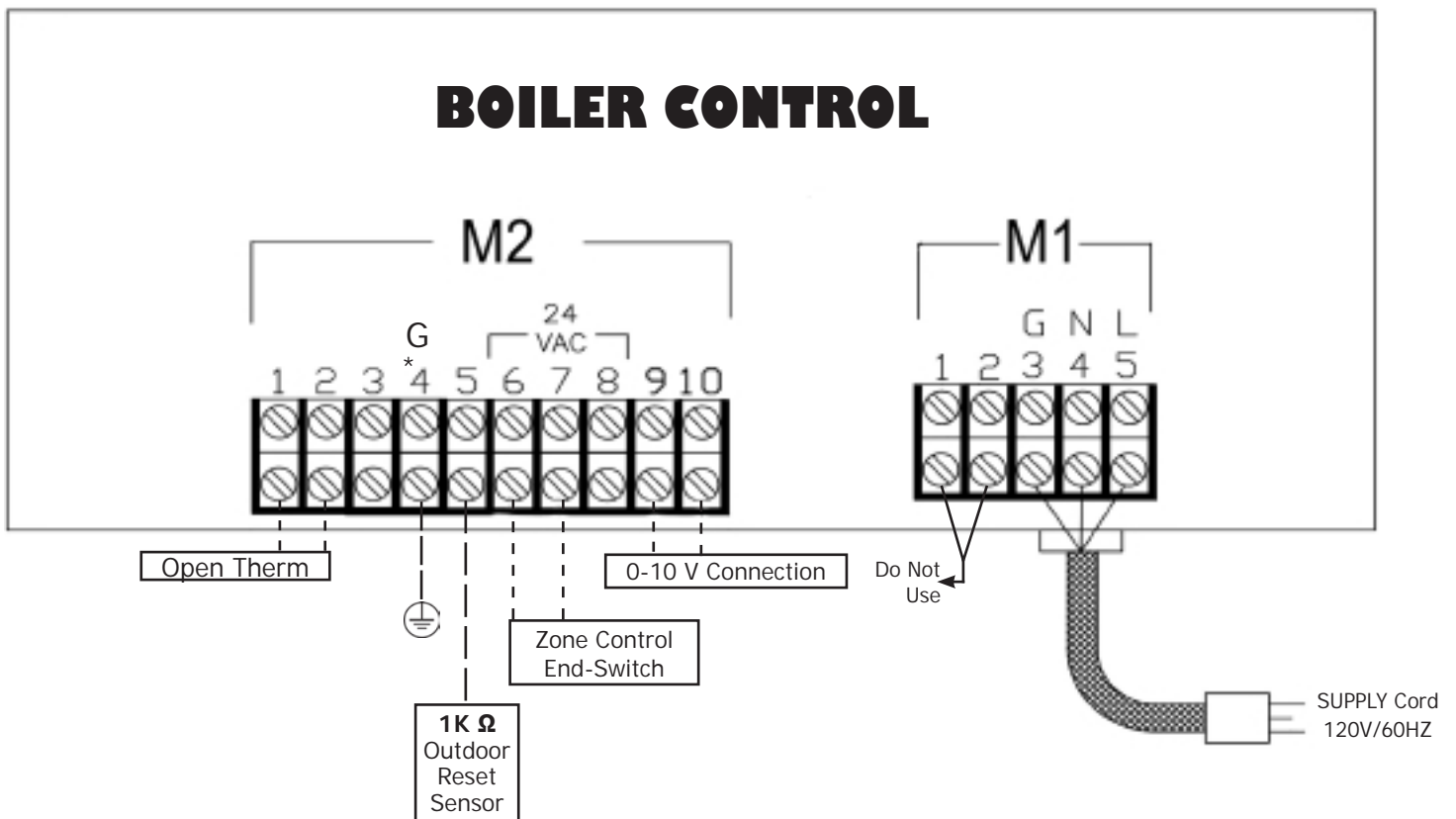









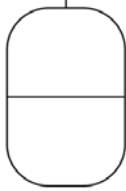

Provided Wiring and Piping illustrations are meant to show system concepts only. Installer is responsible for all equipment required by authority having jurisdiction.

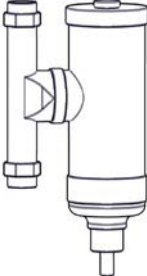

\* Ground Sensors using terminal 4

# PIPING LEGEND

## PIPING LEGEND

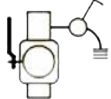
	ZONE VALVE		TEMPERATURE & PRESSURE GAUGE
	BALL VALVE		EXPANSION TANK
	AIR SEPARATOR		FLAT PLATE HEAT EXCHANGER (COMBI ONLY)
	CIRCULATOR		STRAINER
	DRAIN		MAGNETIC DIRT SEPARATOR
	COMBINATION FILL		
	FLOW CHECK VALVE		
	BYPASS VALVE		
	DIVERTER VALVE		
	T&P OR RELIEF VALVE		
	THERMOSTATIC MIXING VALVE		
	PURGE VALVE		



GCWB95F-150 WITH ZONE CIRCULATOR PUMPS

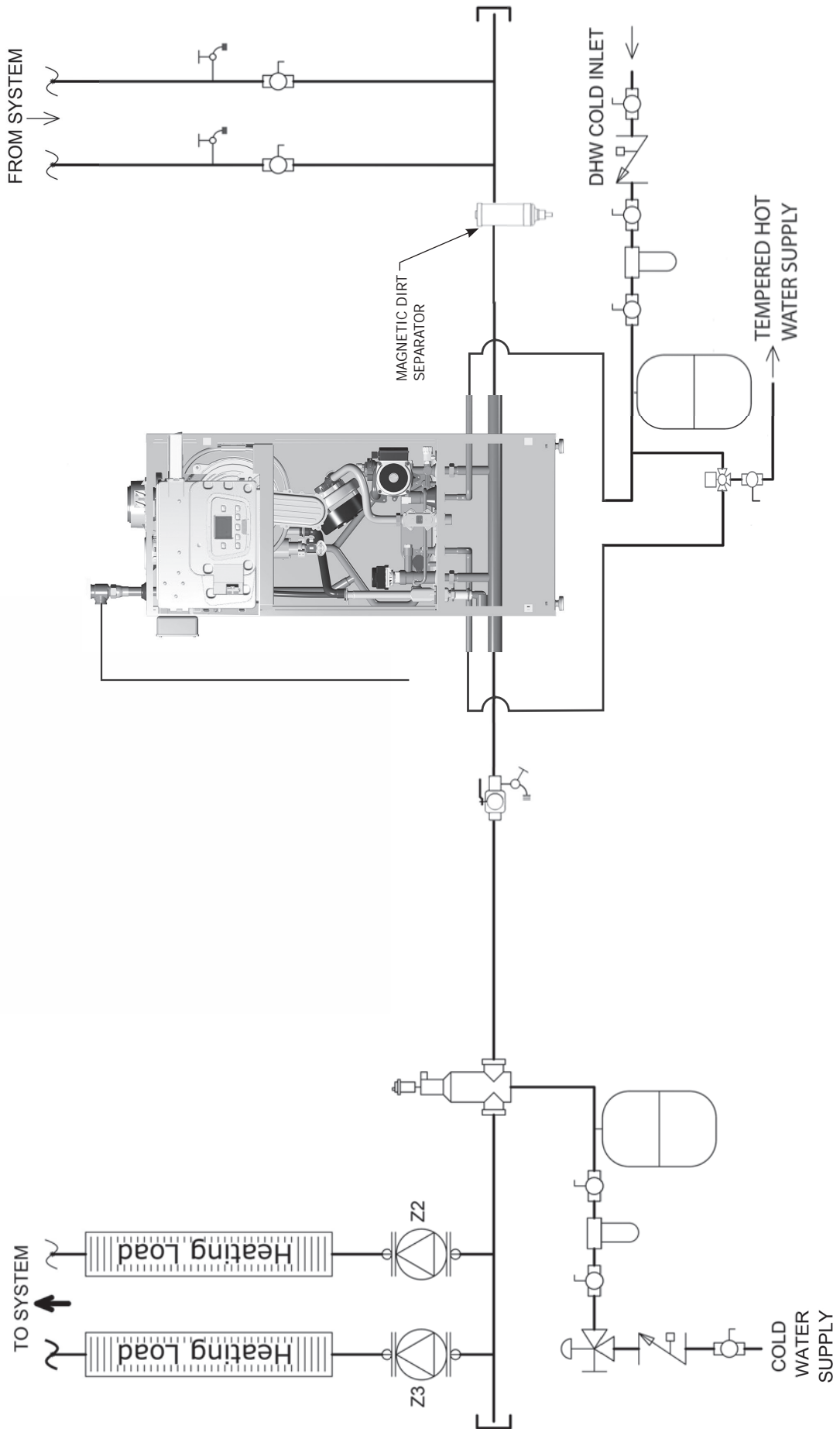

GCWB95F-150 WITH ZONE PUMPS

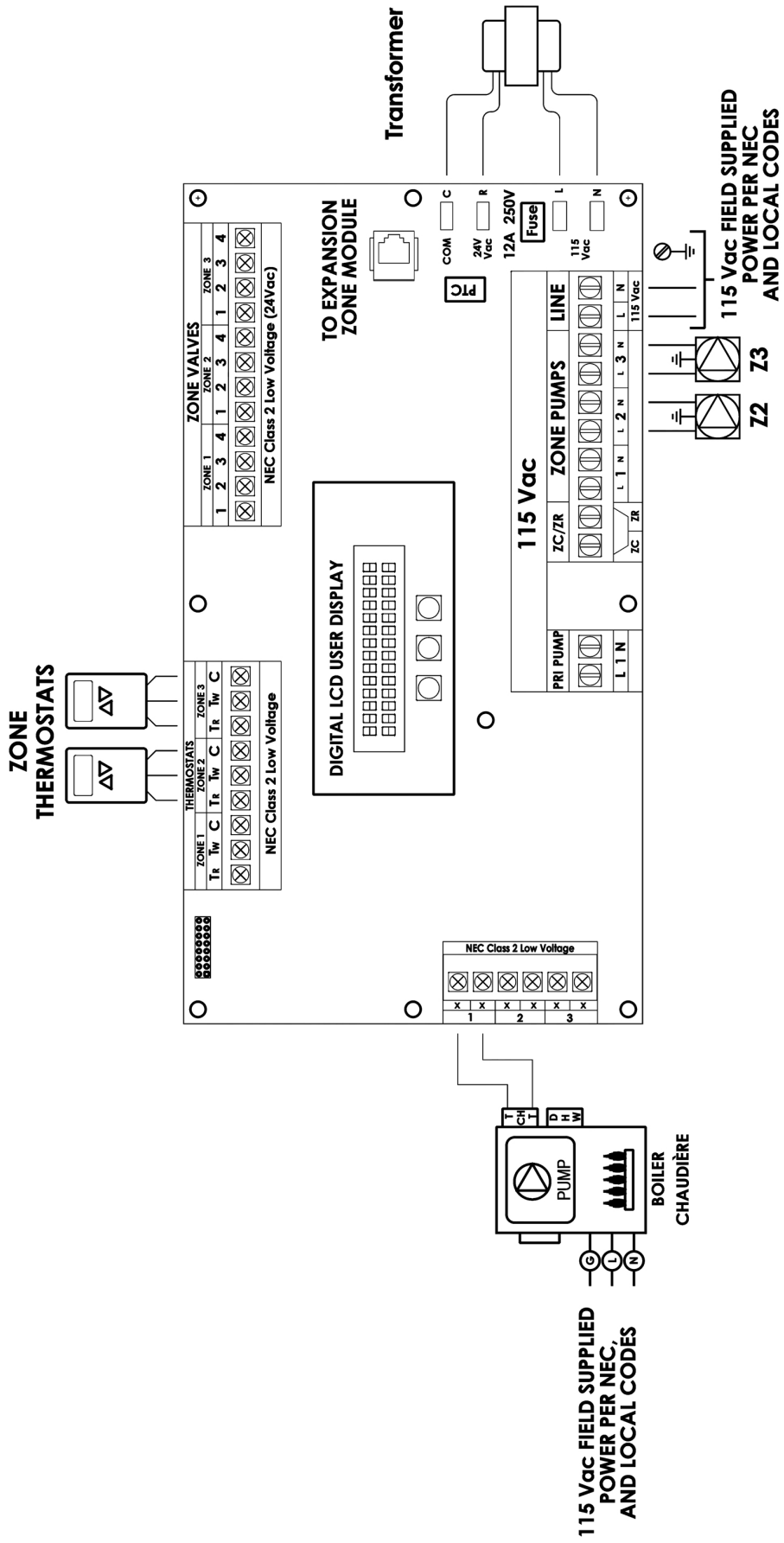

# GCWB95F-150 WITH ZONE VALVES - PIPING DIAGRAM

## GCWB95F-150 WITH ZONE VALVES

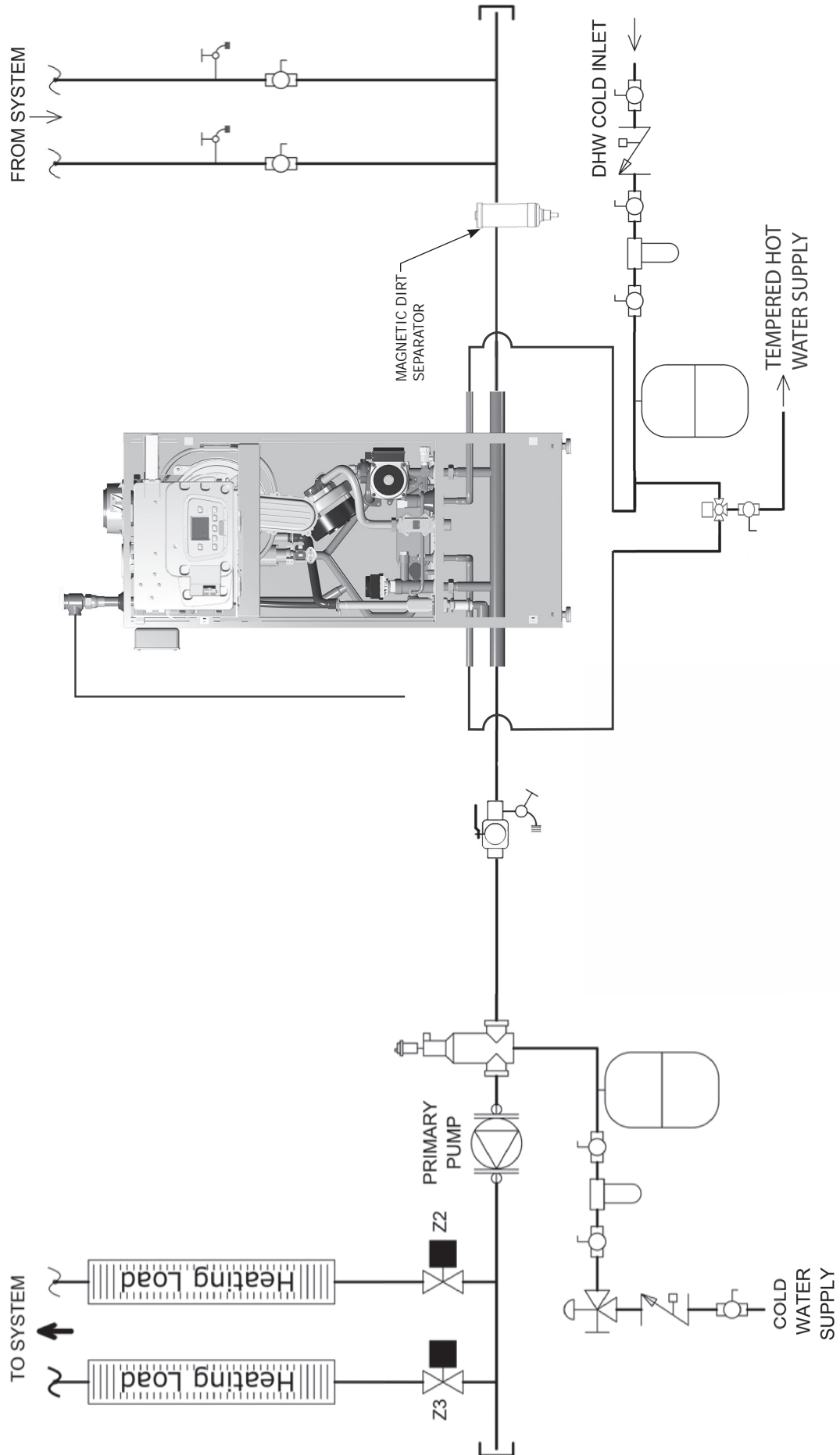

GCWB95F-150 WITH ZONE VALVES

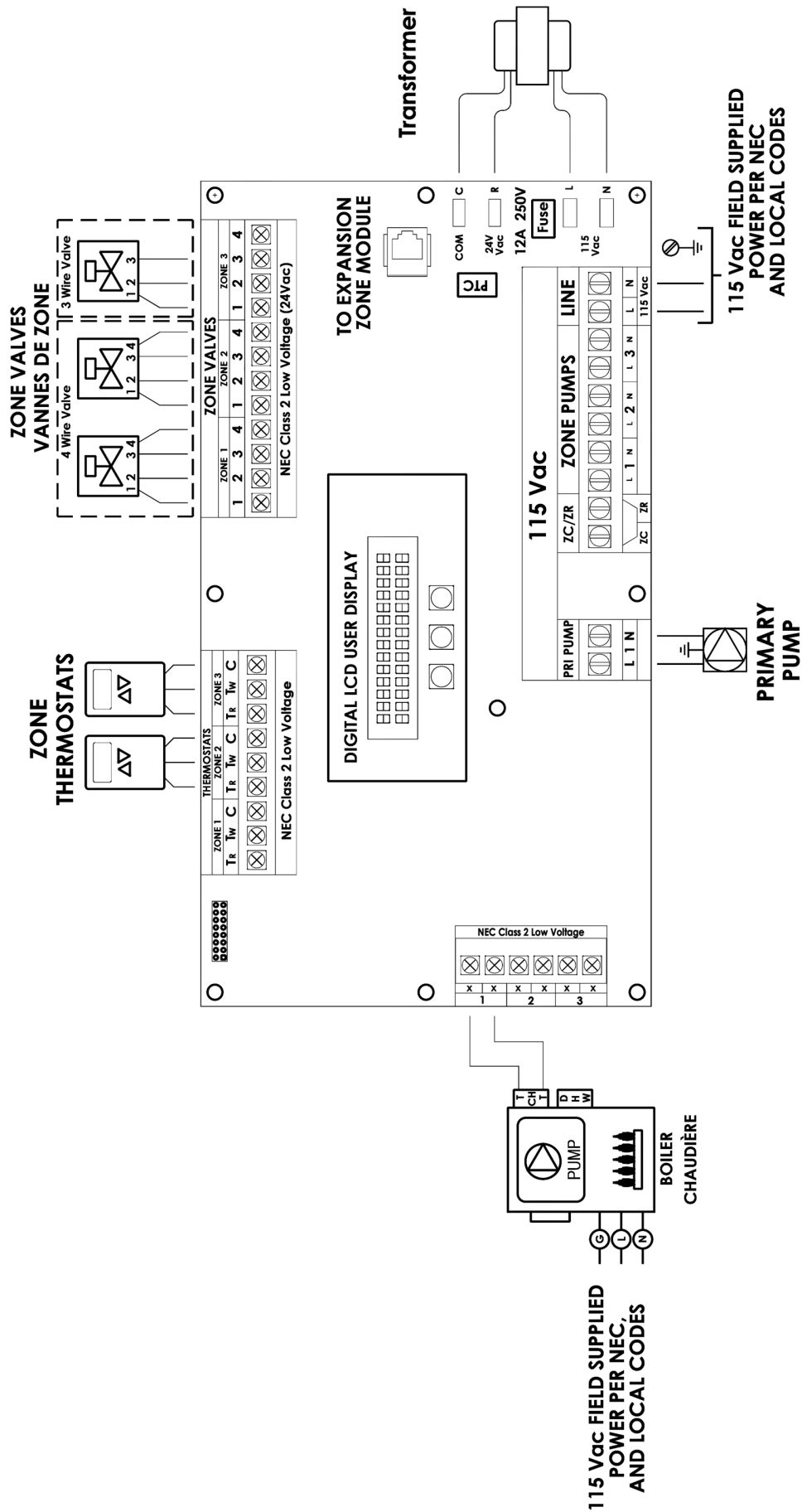

## Buffer Tank Piping

When installing low mass systems, additional water mass may be required to avoid short cycling by the boiler. In these applications it is recommended that a buffer tank be installed.

### Buffer Tank on Central Heat Circuit

**Note:**

- DHW piping not shown for clarity. Reference applicable sections of this manual for DHW piping details.
- Internal Boiler circulator used on Primary circuit.
- Reference Buffer Tank Installation Manual for proper sizing and installation.

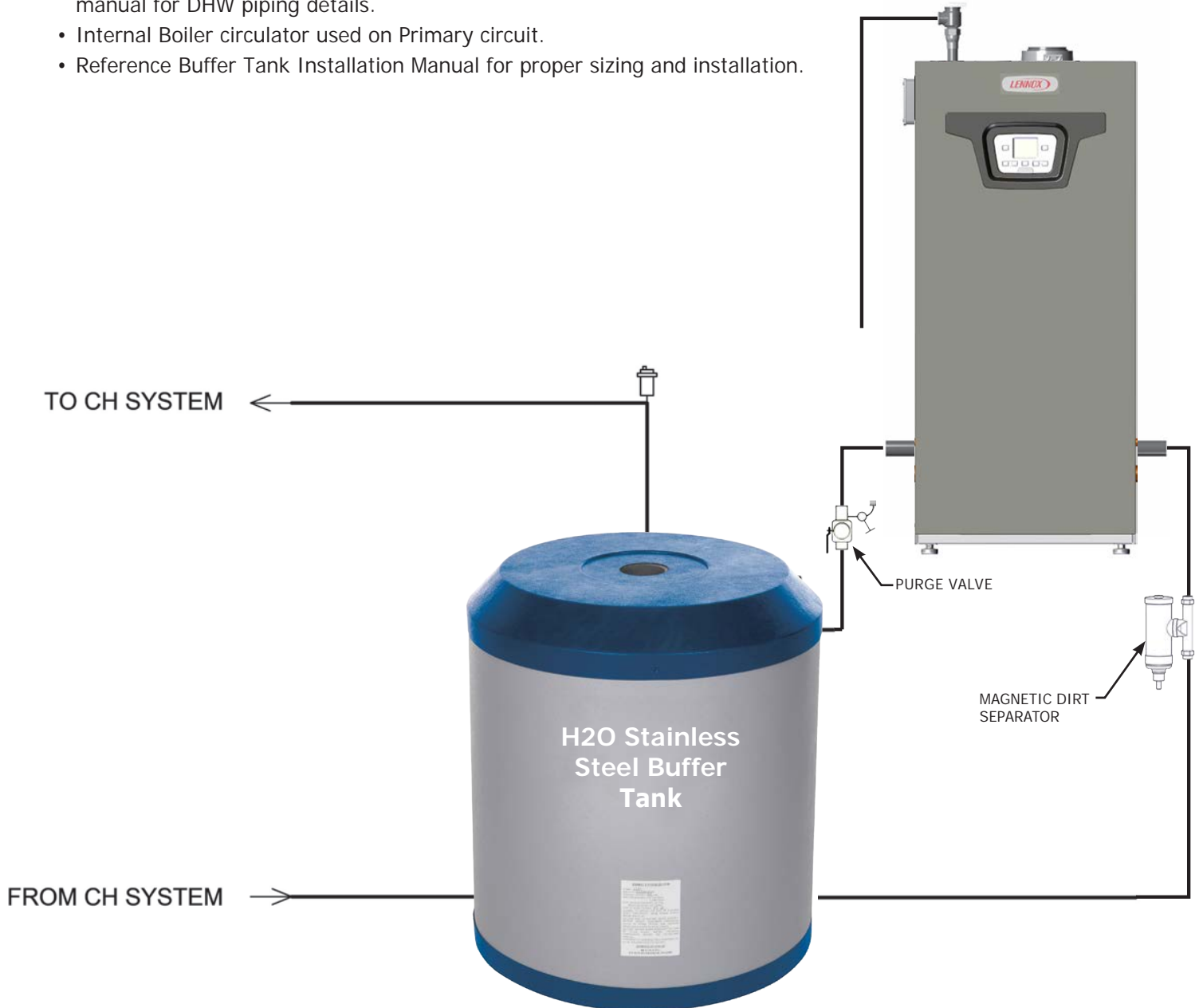

## OPTIONAL EQUIPMENT

### Optional Equipment

**IMPORTANT:** Sensors supplied with this boiler are proprietary to the manufacturer. Use of alternate market sensors *WILL* diminish boiler performance.

1. **1k  $\Omega$**  Outdoor Air Sensor, if used.
  - A. Boiler automatically recognizes sensor when used.
  - B. See Chart 1 for sensor data. Sensor part number BD710487302V
  - C. Locate outdoor sensor to protect against wind and direct sunlight. Mounting instructions provided with sensor.
  - D. Maximum wire length is 100 ft (30m) for 22 ga. wire, or 150 ft (45m) for 18 ga. wire.
  - E. Connect wires to M2 OUTDOOR SENSOR terminals 4 & 5. Wires are interchangeable. See Accessories.

<b>CHART 1 -1k <math>\Omega</math> OUTDOOR AIR SENSOR DATA</b>			
<b>T</b>	<b>R</b>	<b>T</b>	<b>R</b>
<b>[°F]</b>	<b>[Ohm]</b>	<b>[°F]</b>	<b>[Ohm]</b>
-4.0	7,578	53.6	1,690
-2.2	7,193	55.4	1,621
-0.4	6,831	57.2	1,555
1.4	6,489	59.0	1,492
3.2	6,166	60.8	1,433
5.0	5,861	62.6	1,375
6.8	5,574	64.4	1,321
8.6	5,303	66.2	1,268
10.4	5,046	68.0	1,218
12.2	4,804	69.8	1,170
14.0	4,574	71.6	1,125F
15.8	4,358	73.4	1,081
17.6	4,152	75.2	1,040
19.4	3,958	77.0	1,000
21.2	3,774	78.8	962
23.0	3,600	80.6	926
24.8	3,435	82.4	892
26.6	3,279	84.2	858
28.4	3,131	86.0	827
30.2	2,990	87.8	796
32.0	2,857	89.6	767
33.8	2,730	91.4	740
35.6	2,610	93.2	713
37.4	2,496	95.0	687
39.2	2,387	96.8	663
41.0	2,284	98.6	640
42.8	2,186	100.4	617
44.6	2,093	102.2	595
46.4	2,004	100.4	617
48.2	1,920	102.2	595
50.0	1,840	104.0	575
51.8	1,763	106.0	556

## Accessories:

### 1. 1k Ω Outdoor Temperature Sensor Kit - BD710487302V

Use Outdoor Sensor Kit with Heating Only or Combi Boilers. Wire Control to boiler M2 terminal strip terminals #4 and #5 as shown below.

Install/locate Control according to instructions supplied with sensor kit and Installation, Operation and Maintenance Manual (IOM).

#### Setting "Kt" Climate Curve:

Start boiler in CH mode. Depress CH control button once.



Boiler control will recognize installed OAS sensor. Display will change to show current default "Kt" value. Note display value.

When operation in CH mode, **Kt** value setting will override maximum CH boiler control set point based on current outdoor temperature.

- Refer to applicable °F (or °C) chart,
- Identify **Kt** range that will satisfy the desired boiler delivery temperature based on average (extreme) outdoor temperature range expected for climate location.

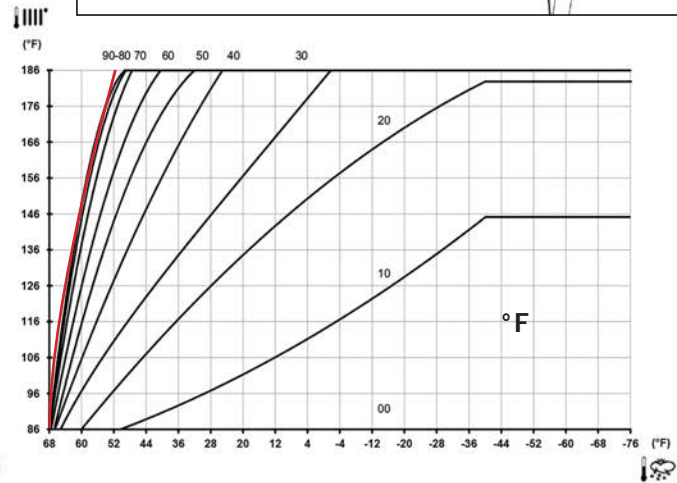
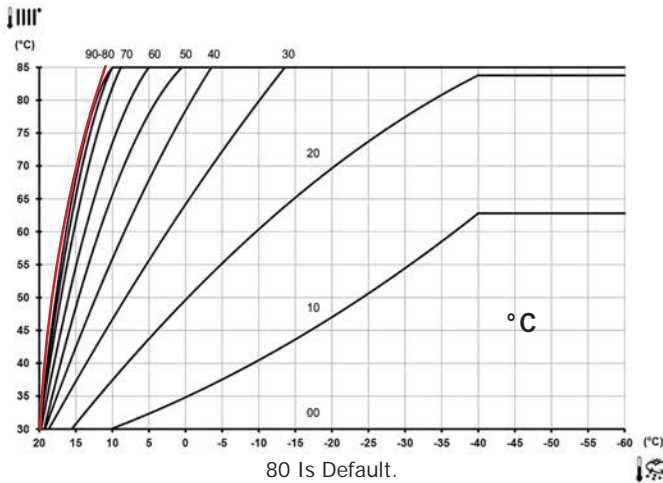

- Use lower value of range as the desired **Kt** value.  
(Example): to deliver 186°F water @ OT of -20°F = **Kt** range is 90 thru 25. Select 25.
- To change "default" **Kt** value on boiler control use +/- CH Heating buttons.

When scrolling has stopped, boiler will automatically "SAVE" value as new **Kt** default value and automatically return to CH mode when no **Kt** adjustment activity is sensed. **Kt** values can be changed in +/- 1 point increments.

To return to check or change current **Kt** "default value" - depress one of the CH set-point adjustment buttons (once), while in any heating or standby mode. Adjust **Kt** value to obtain desired comfort level.

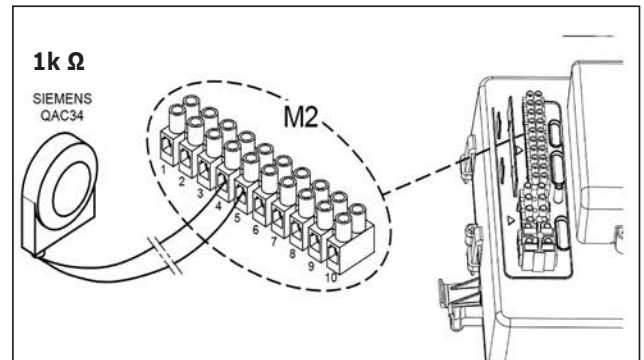

**Note** → For temperatures below -40°F (-40°C), maximum heating flow temperature set point no longer increases and curves on the graph become horizontal. Boiler set point will override sensor setpoint.

#### BUTTONS Key

	DHW temperature adjustment (+ to increase the temperature and - to decrease it)
	Heating water temperature adjustment (+ to increase the temperature and - to decrease it)
	Boiler operating information
	Operating mode: DHW – DHW & Heating – Heating Only
	Off – Reset – Exit menu/functions

#### Boiler Control Panel



## ACCESSORIES

### Management of 0-10V Input

The functions with 0...10V regulator are activated by means of their parameters. When the function is enabled (**P82=3**) and **P78=1**, the input manages the heating set point temperature directly; when **P78=2**, the input manages the heating power input directly. Demand is activated above 3V and the heating setpoint is calculated in proportion to deviation from 3 to 10 V DC, to give a setpoint that goes from minimum to maximum.

GCWB95F-150				
0-10V DC Electrical Signal Input	P78=1		P78 = 2	
	Heating Flow Setpoint Temperature		Central Heating - Heat Input (Gross)	
(V)	(°F)	(°C)	(kW)	(Btu/h)
0...3	OFF			
3	77	25	6.4	22,000
4	95	35	10.8	36,700
5	108	42	15.1	51,400
6	124	51	19.4	66,100
7	140	60	23.7	80,800
8	154	68	28.0	95,500
9	167	75	32.3	110,200
10	176	80	36.6	125,000



# 150F FLOOR STANDING - COMBI WIRING DIAGRAM

## MODEL 150F - Combi

240012700 REV A

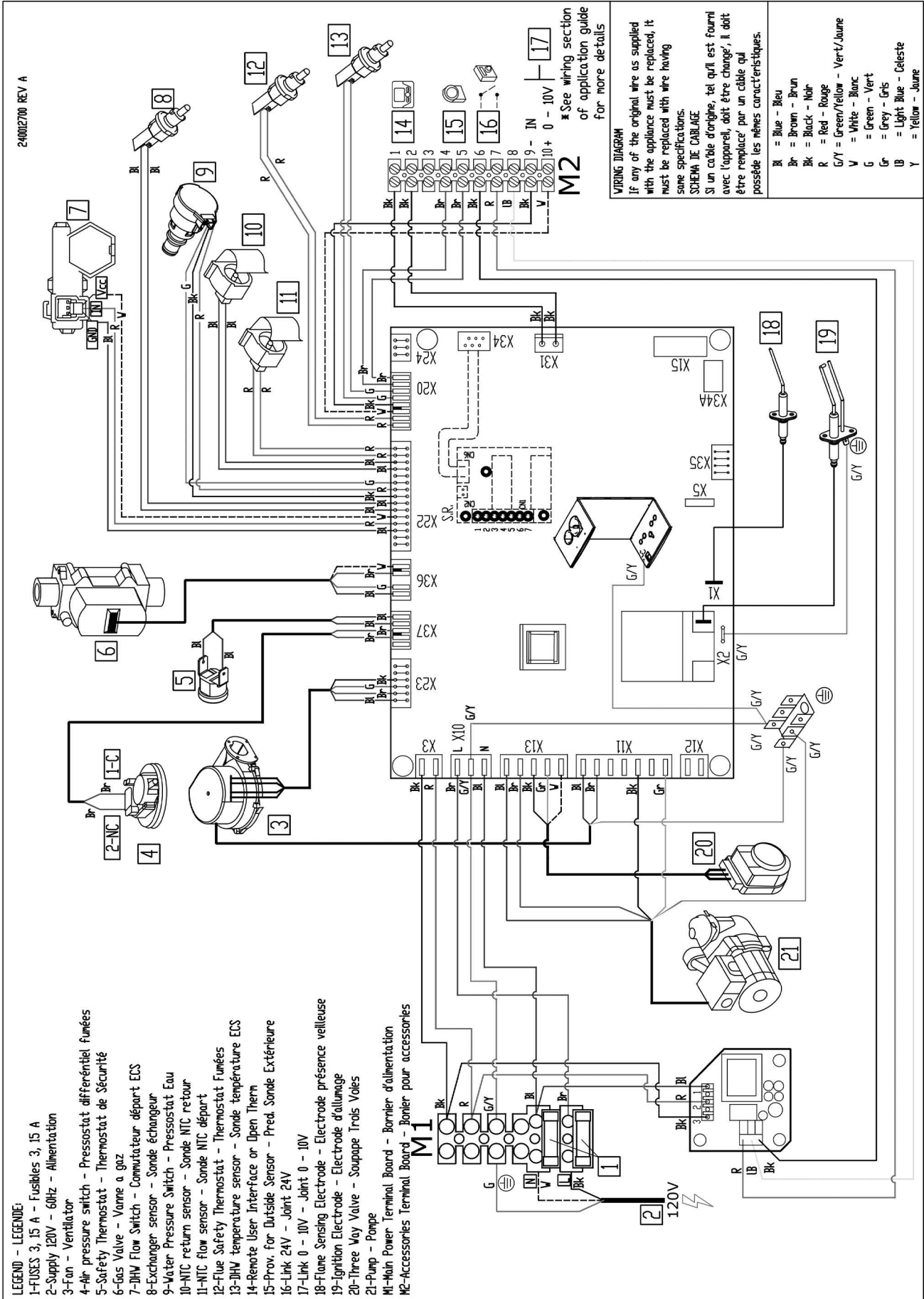

**LEGEND - LEGENDE:**

- 1-FUSES 3, 15 A - Fusibles 3, 15 A
- 2-Supply 120V - 60Hz - Alimentation
- 3-Fan - Ventilator
- 4-Air pressure switch - Pressostat différentiel fumées
- 5-Safety Thermostat - Thermostat de Sécurité
- 6-Gas Valve - Vanne à gaz
- 7-DHW Flow Switch - Commutateur départ ECS
- 8-Exchanger sensor - Sonde échangeur
- 9-Water Pressure Switch - Pressostat Eau
- 10-NTC return sensor - Sonde NTC retour
- 11-NTC flow sensor - Sonde NTC départ
- 12-Flue Safety Thermostat - Thermostat Fumées
- 13-DHW temperature sensor - Sonde température ECS
- 14-Remote User Interface or Open Therm
- 15-Prev. for Outside Sensor - Pred. Sonde Extérieure
- 16-Link 24V - Joint 24V
- 17-Link 0 - 10V - Joint 0 - 10V
- 18-Flame Sensing Electrode - Electrode présence veilleuse
- 19-Ignition Electrode - Electrode d'allumage
- 20-Three Way Valve - Soupape Trois Voies
- 21-Pump - Pompe
- M1-Main Power Terminal Board - Bornier d'alimentation
- M2-Accessories Terminal Board - Bornier pour accessoires

**WIRING DIAGRAM**

If any of the original wire as supplied with the appliance must be replaced, it must be replaced with wire having same specifications.

SCHEMA DE CABLAGE  
Si un câble d'origine, tel qu'il est fourni avec l'appareil, doit être changé, il doit être remplacé par un câble qui possède les mêmes caractéristiques.

- Bk = Blue - Bleu
- Br = Brown - Brun
- R = Red - Rouge
- G/Y = Green/Yellow - Vert/Jaune
- V = White - Blanc
- Gr = Green - Vert
- IB = Grey - Gris
- Y = Light Blue - Céleste
- = Yellow - Jaune

## Model GCWB95F-150

### CALCULATED EFFECTS OF HI-ALTITUDE ON BOILER PERFORMANCE

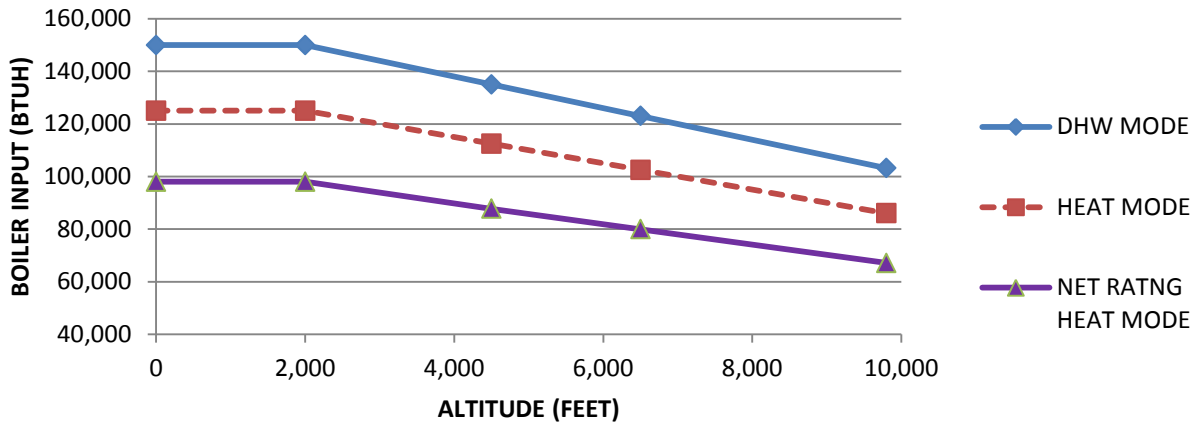

## A - LOW WATER CUTOFF

### Low Water Cut Off

These guidelines are supplied when necessary to install an additional Low Water Cut Off (LWCO), for sensing a low water level condition in a boiler, as required by the Authority Having Jurisdiction.

Follow LWCO manufacturer installation instructions for type of LWCO selected in addition to these instructions.

LWCO shall be 120V/60HZ control and dry contacts sized for load being connected. Wire control to boiler. See Figure 1.

Connect LWCO device to the system ground. Ground in accordance with the requirements of the authority having jurisdiction or, in the absence of such requirements, with the National Electrical Code (NEC) or Canadian Electrical Code CEC.

- Locate LWCO sensing device in the supply piping, above the minimum height of boiler. See Figure A-2, Piping Diagram.
- Position control in HORIZONTAL piping to assure proper boiler protection (upright or 90° rotation).
- For proper operation, sensing element of the LWCO control shall be positioned in the tee to sense the main water stream. Maintain minimum 1/4" spacing from pipe walls. Element shall NOT contact the rear, or side walls of the tee. See Figure A-3.
- Install an air vent using a tee to avoid nuisance shutdowns.
- Apply small amount of pipe sealant to threaded connections.
- Arrange piping to prevent water dripping onto boiler.
- DO NOT install water shutoff valve between boiler and LWCO sensing device.

### LWCO Wiring Diagram

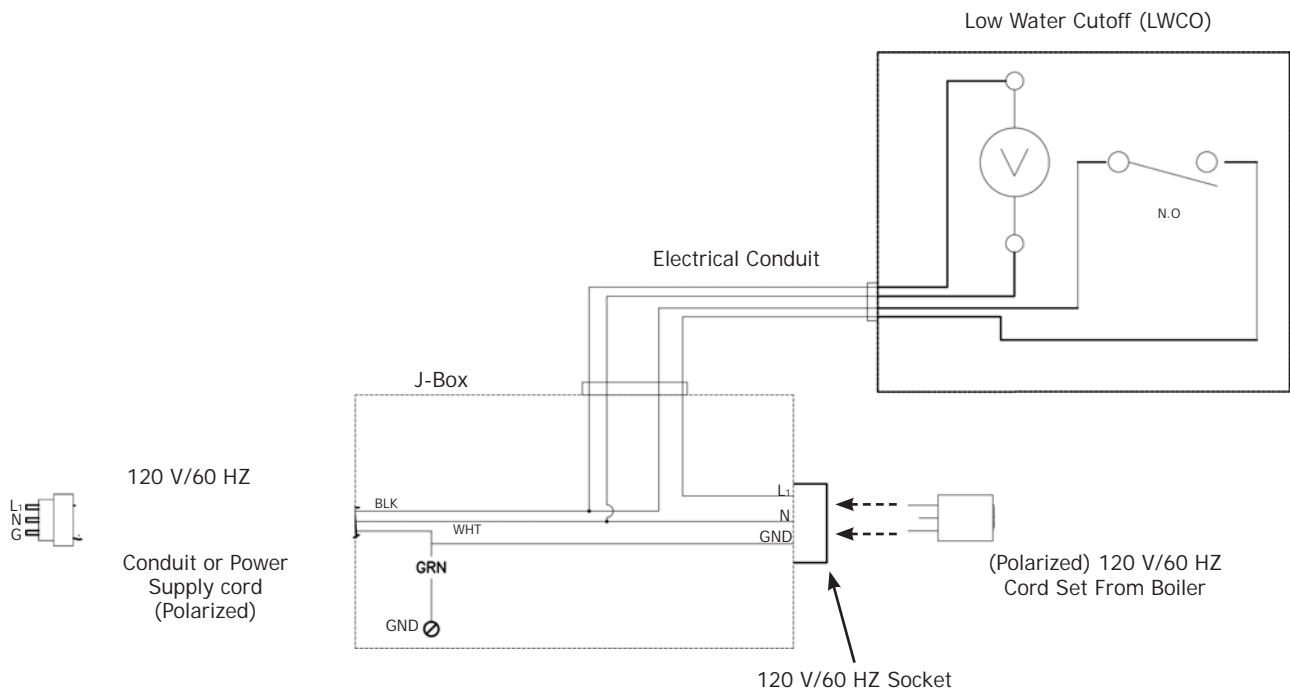

# LOW WATER CUTOFF

## Piping Diagram - LWCO Location

**Note** Arrange piping to prevent water dripping onto boiler.

**Note** Illustrations are meant to show system piping concept only. Installer is responsible for all equipment and detailing required by authority having jurisdiction.

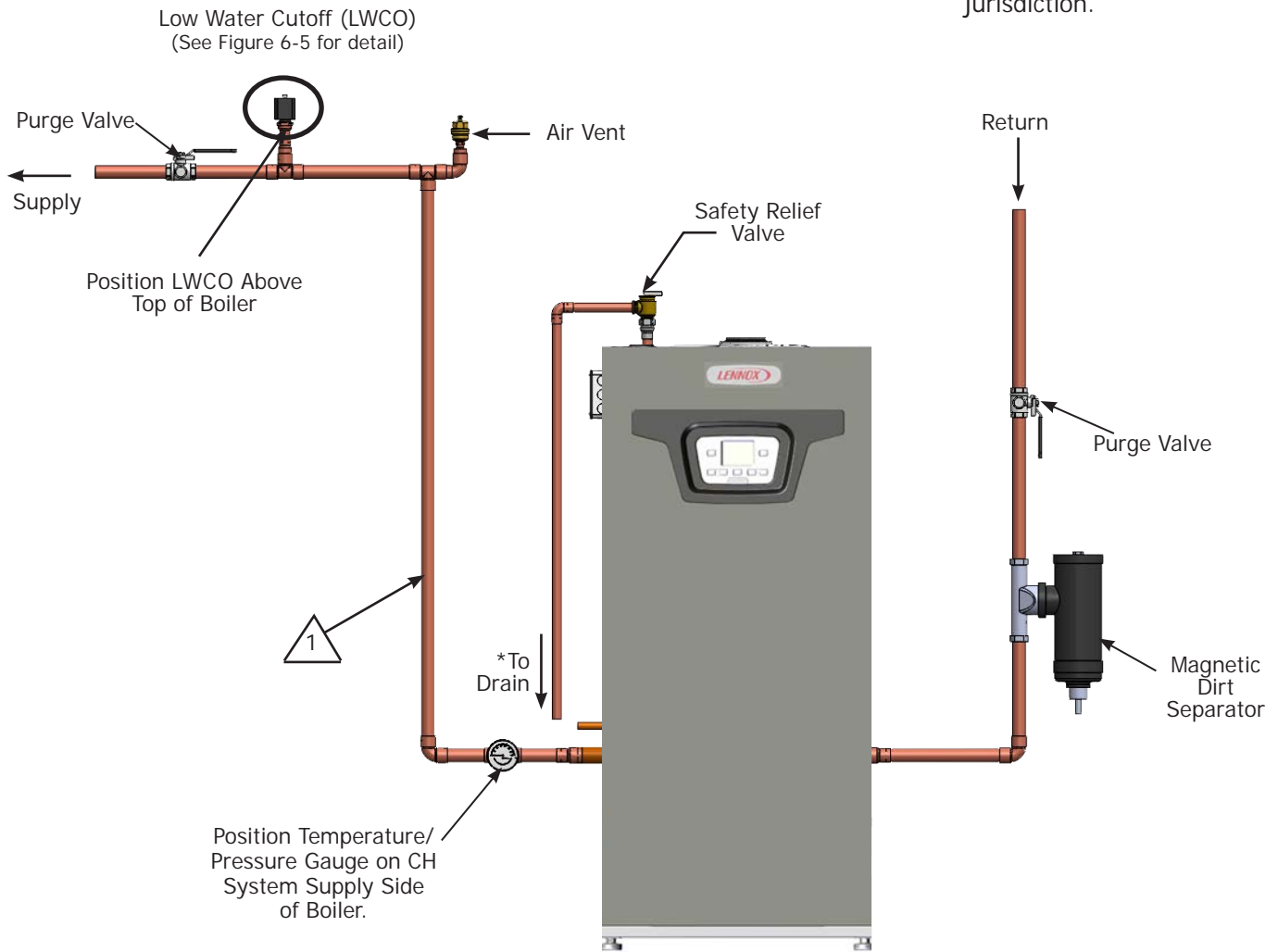

\* Check Local Codes for Maximum Distance to Floor.

**Note**  DO NOT PLACE ISOLATION VALVE BEFORE TEE OR LWCO.

Low Water Cutoff - Detail

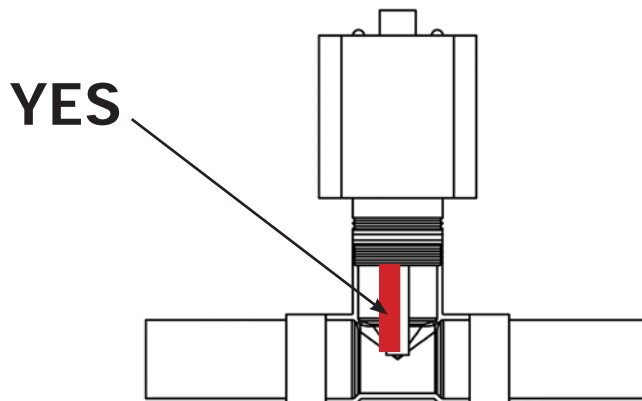
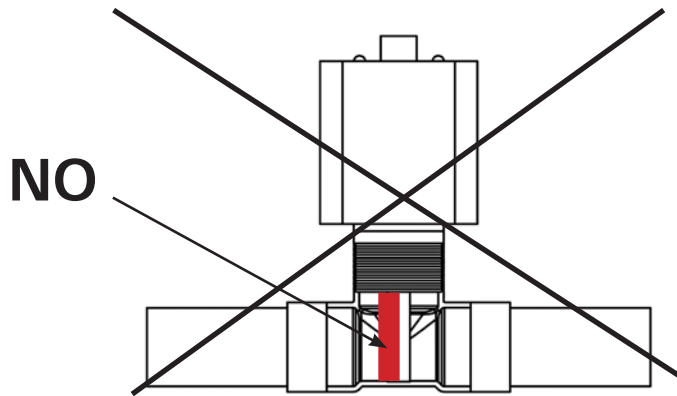
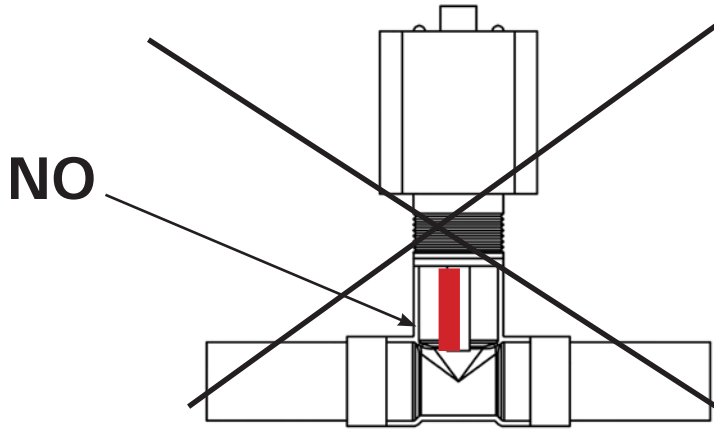

# ERROR CODE TABLE

NOTE: When instructed press and hold the 'Reset' for between 1-3 seconds to reset the boiler.

## Table Of Error Codes

E 09	Gas valve connection cable
E 10	External probe fault
E 12	Water flow switch open
E 13	Water flow switch close
E 15	gas valve fault
E 18	Water refill enabled
E 19	Max time of water refill
E 20	Central Heating Flow NTC Fault
E 28	Flue NTC Fault
E 40	Central Heating Return NTC Fault
E 50	Hot Water NTC Fault (tank version)
E 53	Obstruction on the flue pipe- combustion off
E 55	PCB to be set by the "Calibration Function"
E 71	Fan parameter Out of range in autocalibration
E 72	Combustion test Out of range in autocalibration
E 77	Current out of range
E 78	Minimum gas valve current
E 79	Maximum gas valve current
E 83-87	Communication error
E 92	Combustion test alarm during auto-setting
E 109	Pre-Circulation Fault
E 110	Safety Thermostat Operated
E 117	System Water Pressure Too High
E 118	System Water Pressure Too Low
E 125	Circulation Fault (Primary Circuit)
E 128	Flame Failure
E 129	Frequently loss of flame during the ignition
E 130	Flue NTC Operated
E 133	Interruption Of Gas Supply or Flame Failure
E 134	Elapsed time Gas valve open without gas
E 135	Interruption Of Gas Supply (internal error)
E 160	Fan or Fan Wiring Fault
E 321	Domestic Hot Water NTC sensor fault
E 384	False flame
E 385	Under voltage

## Initial Fault Finding Checks

1. Check that gas, water and electrical supplies are available at the boiler.
2. Electrical supply = 120V ~60 Hz.
3. The preferred minimum gas pressure is 3.5"wc for Natural gas and 10"wc for LPG.
4. Carry out electrical system checks, i.e. Ground Continuity, Resistance to Ground, Short Circuit and Polarity with a suitable meter.

NOTE: These checks must be repeated after any servicing or fault finding.

5. Ensure all external controls are calling for heat and check all external and internal fuses. Before any servicing or replacement of parts, ensure the gas and electrical supplies are isolated.

1. If a fault occurs on the boiler an error code may be shown by the facia display.

E 20, E 28, E 40, E 50, E 160, E 321 and E 431 indicate possible faulty components.

E 53 shows possible obstruction in the flue duct.

E 55 indicates that the pcb is not setting/calibrated.

E 71, E 72, E 77, E 78 e E 92 indicate possible wrong calibration. A new calibration is needed.

E 92 shows possible flue recirculation in the flue duct.

E 83...87 shows possible error of communication with thermostat (Goto section P)

E 110 shows overheat of the primary.

E 117 is displayed when the primary water pressure is more than 43 psi.

E 118 is displayed when the primary water pressure is less than 7.25psi.

E 125 is displayed in either of two situations:-  
 i) If within a time between 15..30 seconds of the burner lighting the boiler temperature has not changed by 2°F.  
 ii) If within 10 minutes of the burner lighting the boiler temperature twice exceeds the selected temperature by 80°F. In these instances poor primary circulation is indicated.

E 128 is displayed if there has been a flame failure during normal burner operation.

E 133 , E 134 and E 135 indicate that the gas supply has been interrupted, ignition has failed or the flame has not been detected.

2. By pressing the 'Reset' button for between 1-3 seconds when E 110, E 125, E 133, E 134, E 135 , E 09, E 15, E 128 and E 384 are displayed it is possible to relight the boiler.

3. If this does not have any effect, or error codes are displayed regularly further investigation is required.

# TROUBLESHOOTING CHART

## Central Heating

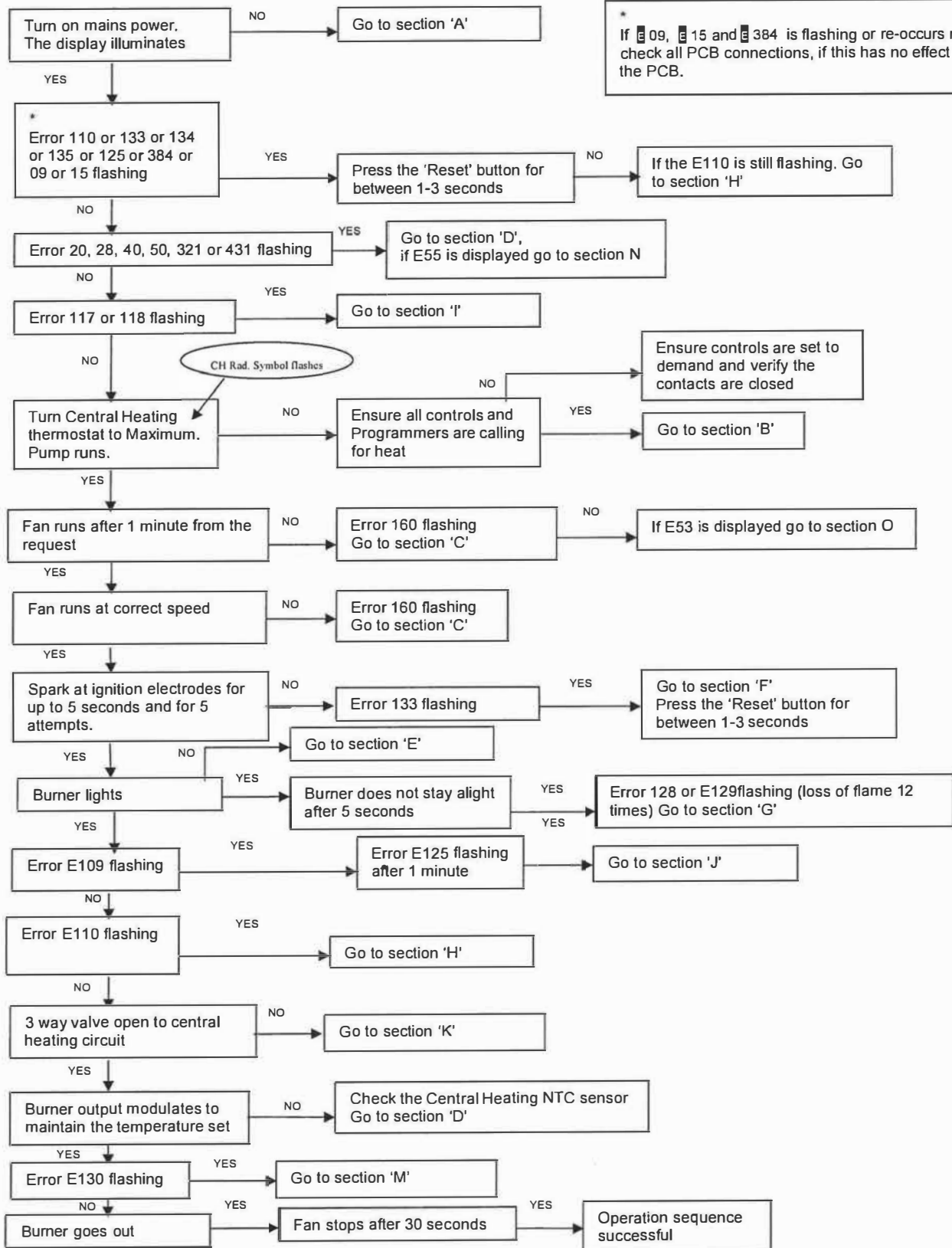

\* If 09, 15 and 384 is flashing or re-occurs regularly check all PCB connections, if this has no effect replace the PCB.

CH Rad. Symbol flashes

# TROUBLESHOOTING CHART

## Domestic hot water

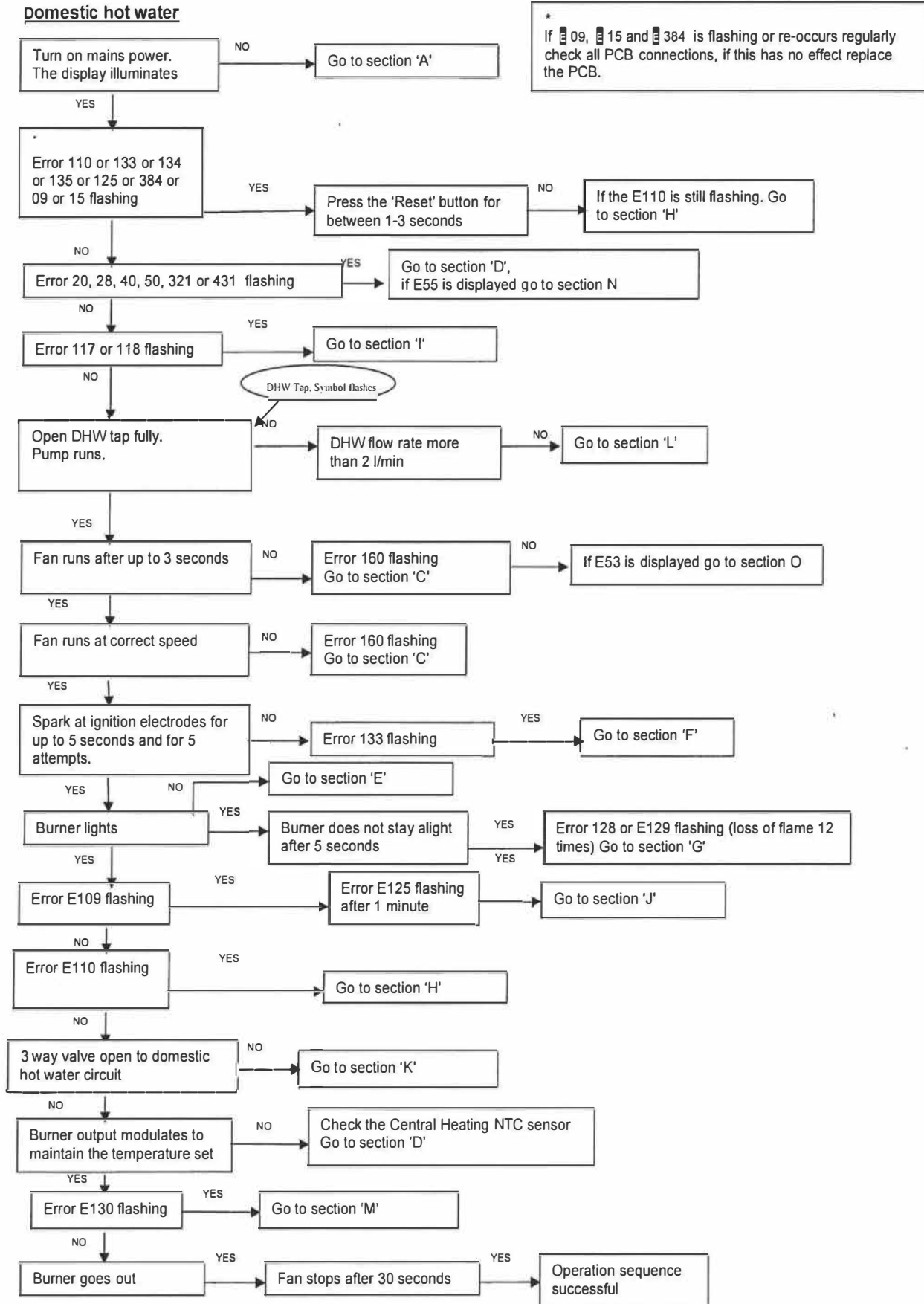



## Fault Finding Solutions Sections

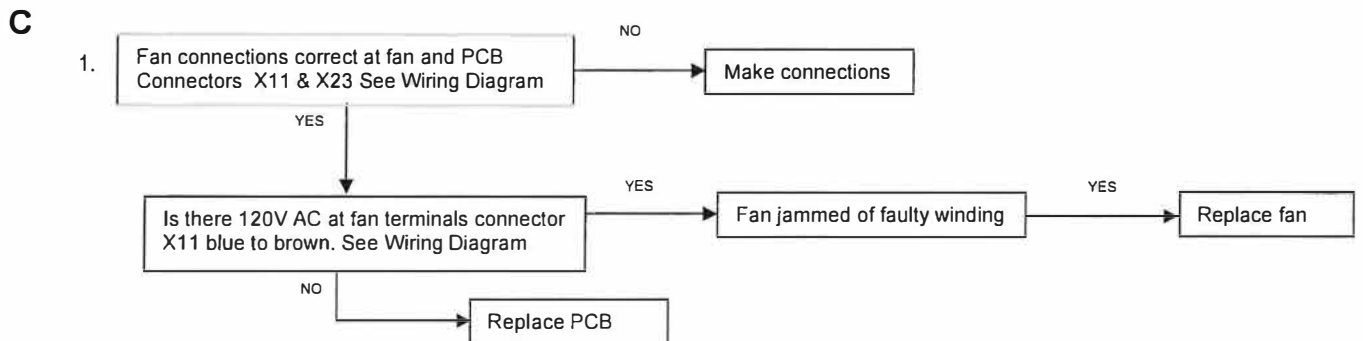
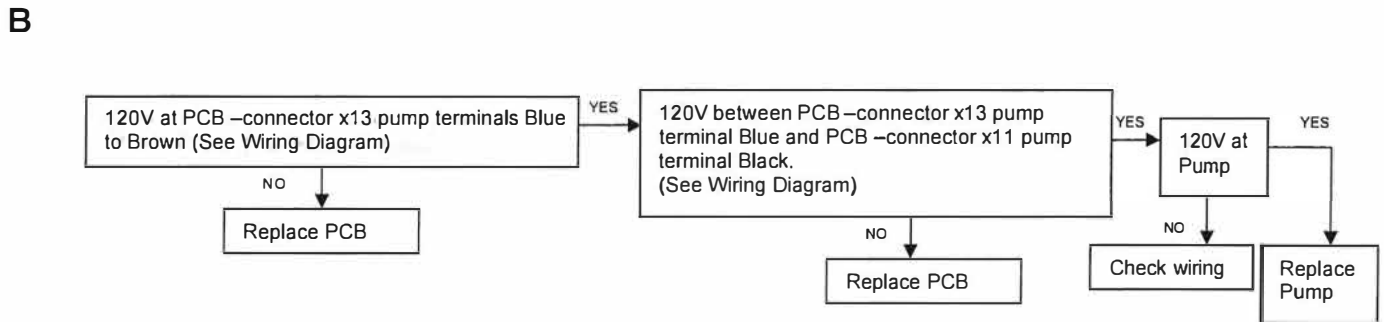
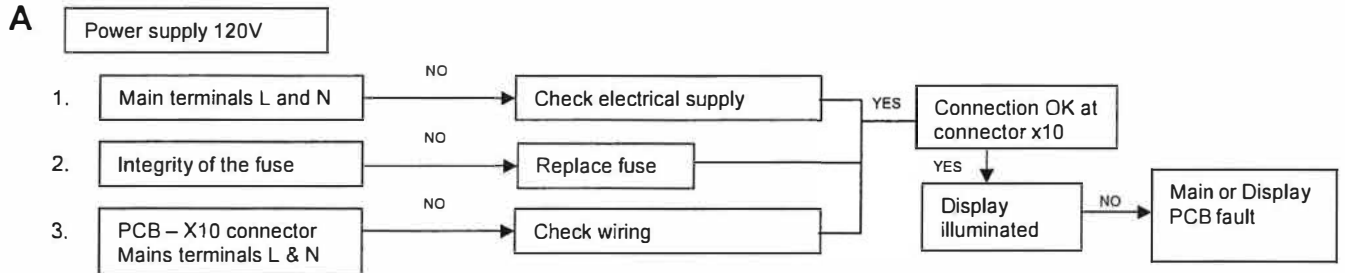

## FAULT SOLUTION SECTIONS

**D**

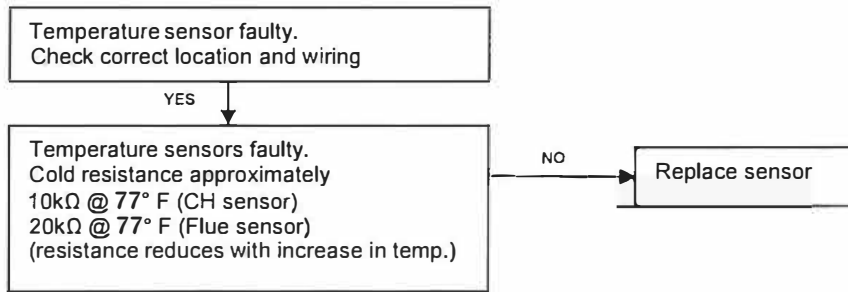

**E**

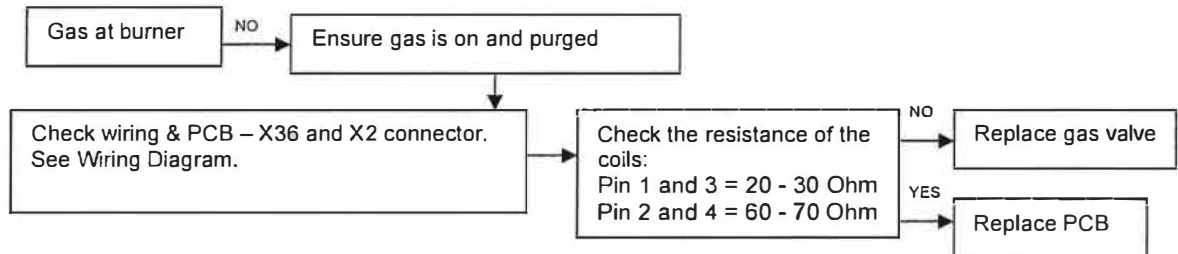

**F**

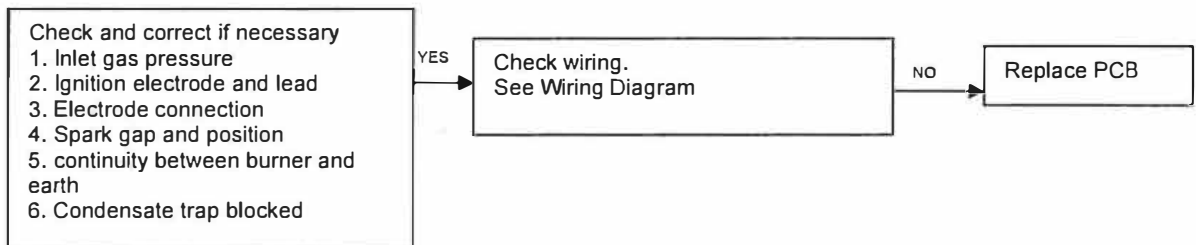

**G**

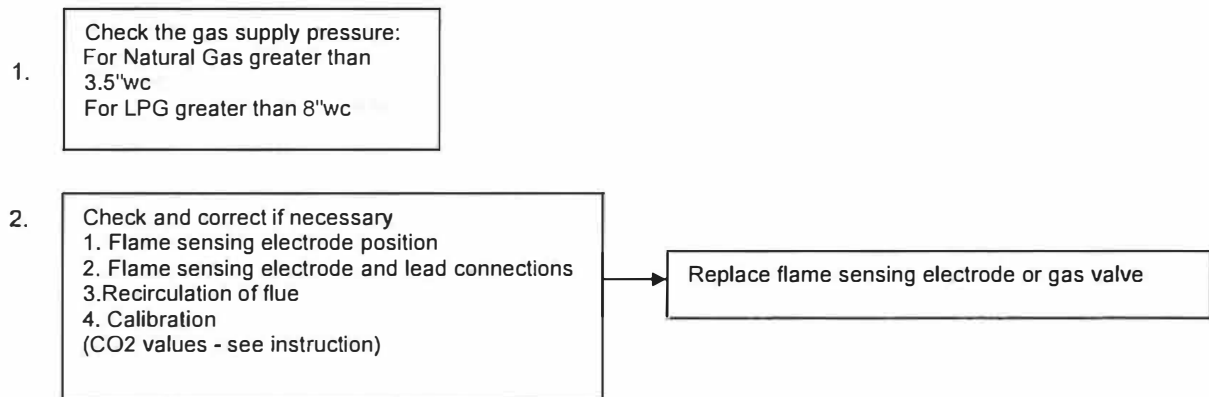

# FAULT SOLUTION SECTIONS

**H**

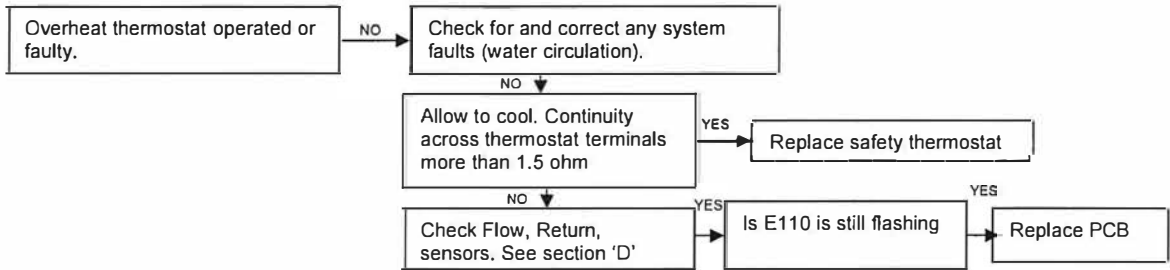

**I**

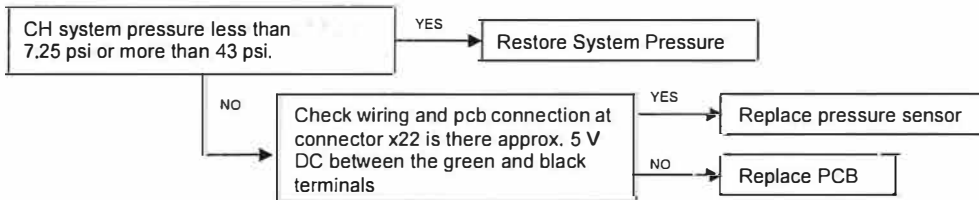

**J**

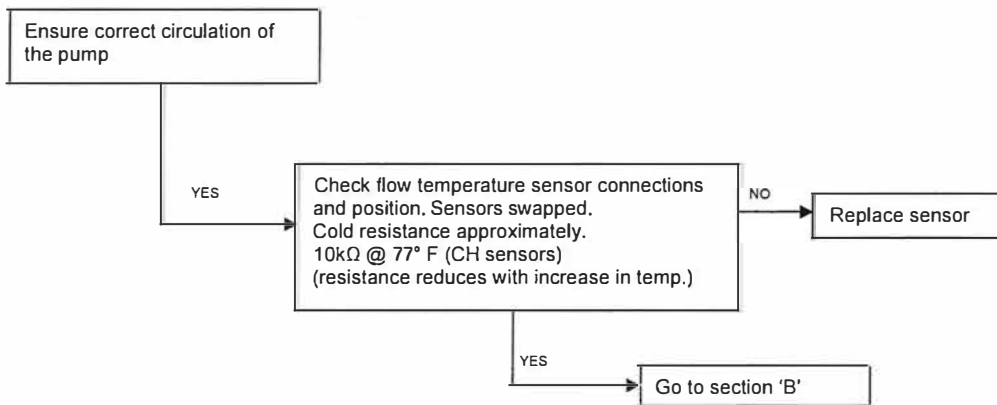

**K**

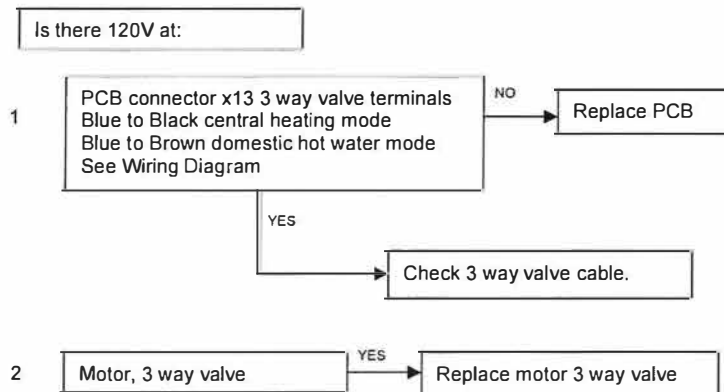

## FAULT SOLUTION SECTIONS

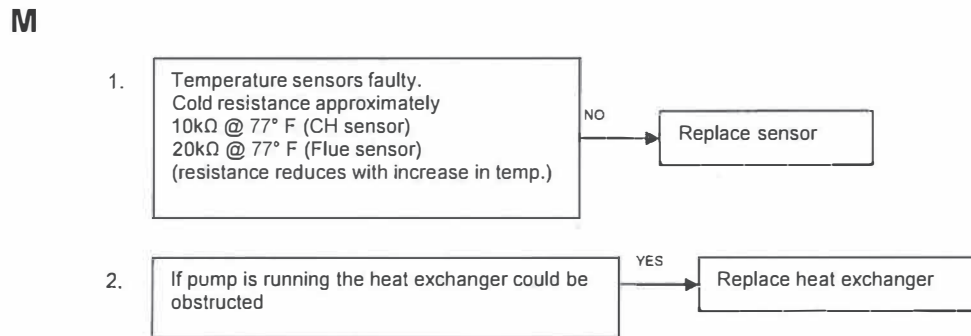
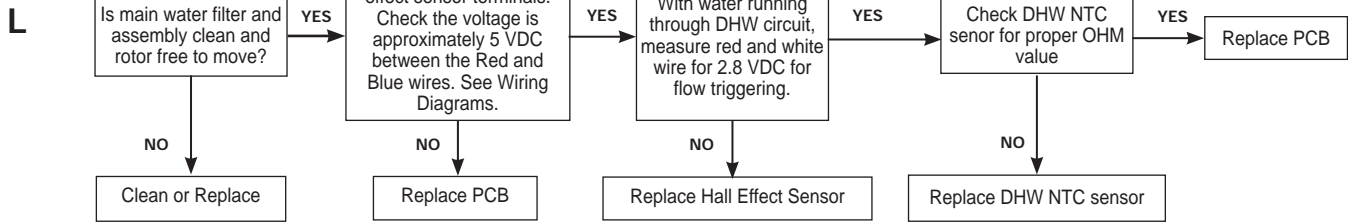

**N**

Performs the autocalibration function (see the Service manual)

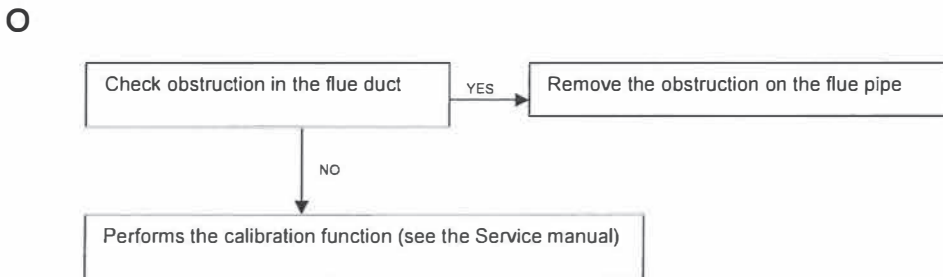
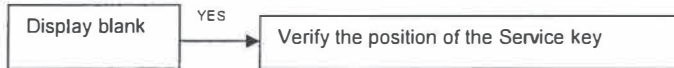

**P**

Check the electrical connection between Ru and pcb

