

INSTALLATION AND MAINTENANCE INSTRUCTIONS SCU14M Series Split System Air Conditioner

⚠ WARNING

The equipment covered in this manual is to be installed by trained and experienced service and installation technicians. Improper installation, modification, service, or use can cause electrical shock, fire, explosion, or other conditions which may cause personal injury, death, or property damage. Use appropriate safety gear including safety glasses and gloves when installing this equipment.

⚠ WARNING

Risk of electrical shock. Disconnect all remote power supplies before installing or servicing any portion of the system. Failure to disconnect power supplies can result in property damage, personal injury, or death.

⚠ WARNING

Installation and servicing of air conditioning equipment can be hazardous due to internal refrigerant pressure and live electrical components. Only trained and qualified service personnel should install or service this equipment. Installation and service performed by unqualified persons can result in property damage, personal injury, or death.

⚠ WARNING

Sharp metal edges can cause injury. When installing the unit, use care to avoid sharp edges.

TABLE OF CONTENTS

UNIT DIMENSIONS	2
INSTALLATION	3
START-UP	10
OPERATION	12
MAINTENANCE	12
CONNECTION DIAGRAM	14
WARRANTY	15

Manufactured By
A.A.C.

A *Lennox International Company*
421 Monroe Street
Bellevue, OH 44811



Save these instructions for future reference

UNIT DIMENSIONS

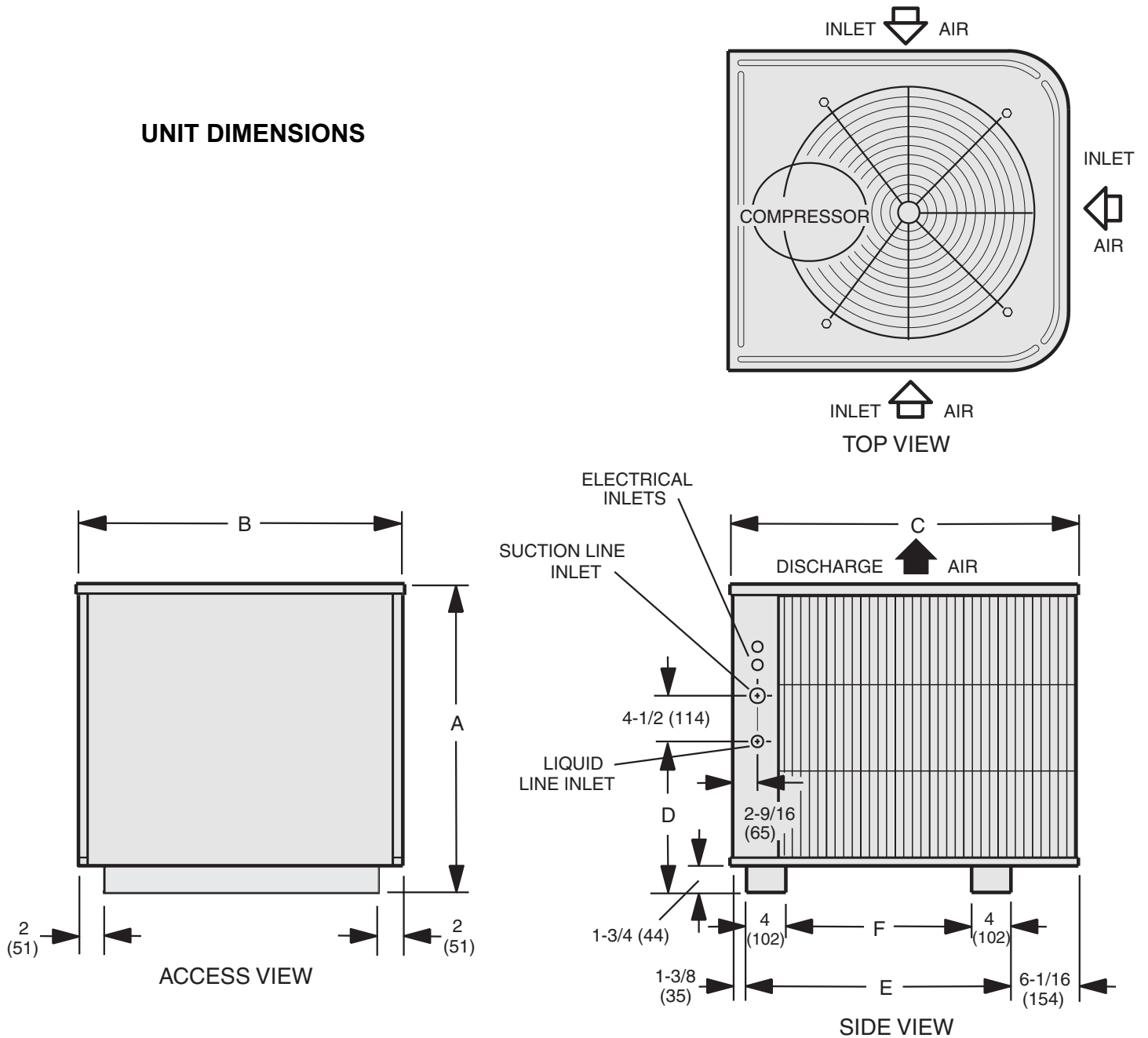

Model Number		A	B	C	D	E	F
SCU14M-024	in.	26-7/8	25-7/8	29-7/8	11-1/2	22-7/16	14-7/16
	mm	683	657	759	292	570	367
SCU14M-030 SCU14M-036 SCU14M-042	in.	29-7/8	32-1/8	34-1/16	12	26-5/8	18-5/8
	mm	759	816	865	305	676	473
	in.	33-7/8	32-1/8	34-1/16	13	26-5/8	18-5/8
SCU14M-048	mm	861	816	865	330	676	473
	in.	39-7/8	32-1/8	34-1/16	19	26-5/8	18-5/8
SCU14M-060	mm	1013	816	865	483	676	473

INSTALLATION

General

Read this entire instruction manual, as well as the instructions supplied in separate equipment, before starting the installation. Observe and follow all warnings, cautions, instructional labels, and tags. Failure to comply with these instructions could result in an unsafe condition and/or premature component failure.

These instructions are intended as a general guide only for use by qualified personnel and do not supersede any national or local codes in any way. The installation must comply with all provincial, state, and local codes as well as the National Electrical Code (U.S.) or Canadian Electrical Code (Canada). Compliance should be determined prior to installation.

SCU14M condensing units use R410A which is an ozone friendly HFC refrigerant. This unit must be installed with a matching indoor coil and line set. SCU14M units are designed for use in expansion valve systems only. They are not designed to be used with other refrigerant flow control devices. An expansion valve and filter drier approved for use with 410A have been shipped with the unit. These components must be installed prior to unit operation.

Inspection of Shipment

Upon receipt of equipment, carefully inspect it for possible shipping damage. If damage is found, it should be noted on the carrier's freight bill. Take special care to examine the unit inside the carton if the carton is damaged. Any concealed damage discovered should be reported to the last carrier immediately, preferably in writing, and should include a request for inspection by the carrier's agent.

If any damages are discovered and reported to the carrier **DO NOT INSTALL THE UNIT, as claim may be denied.**

Check the unit rating plate to confirm specifications are as ordered.

Torque Table	
Fastener	Torque
Gauge Port Seal Caps	8 ft. lbs.
Service Valve Caps	8 ft. lbs.
#8 & #10 Sheet Metal Screws	16 in. lbs.
#10 Machine Screws	28 in. lbs.
Compressor Bolts	90 in. lbs.

Table 1

Location of Unit

Refer to **UNIT DIMENSIONS** on page 2 for sizing mounting slab, platforms, or supports. Refer to Figure 1 below for installation clearances.

Slab Mounting

When installing unit at grade level, install on a level slab high enough above grade to allow adequate drainage of water. Top of slab should be located so runoff water from higher ground will not collect around unit.

Roof Mounting

Install unit at a minimum of 4" above surface of the roof. Care must be taken to ensure weight of unit is properly distributed over roof joists and rafters. Either redwood or steel supports are recommended.

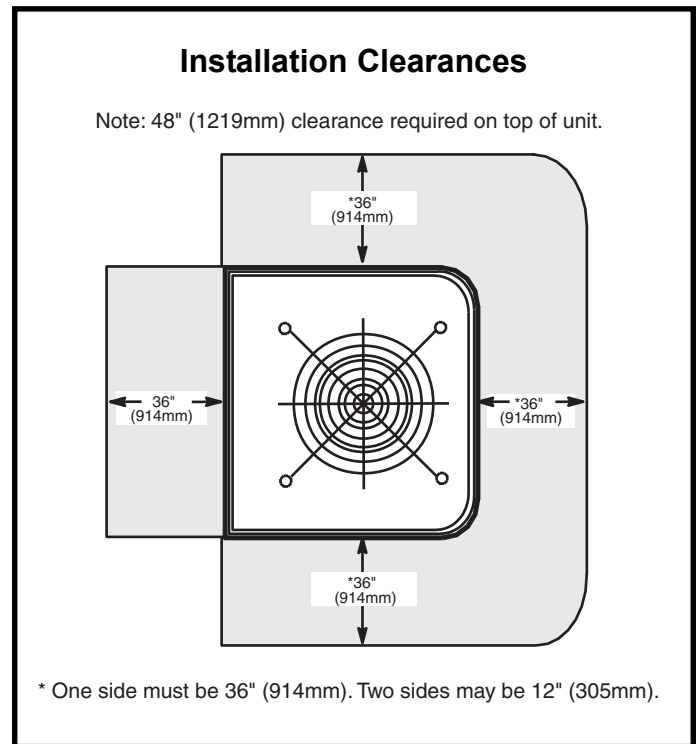

Figure 1

Electrical Wiring

All field wiring must be done in accordance with the National Electrical Code (NEC) recommendations, Canadian Electrical Code (CEC) and CSA Standards, or local codes, where applicable.

Refer to the furnace or blower coil Installation Instructions for additional wiring application diagrams and refer to unit rating plate for minimum circuit ampacity and maximum overcurrent protection size.

Unit must be grounded in accordance with national and local codes.

1. Install line voltage power supply to unit from a properly sized disconnect switch.
2. Install room thermostat on an inside wall that is not subject to drafts, direct sunshine, or other heat sources.
3. Install low voltage wiring from outdoor to indoor unit and from thermostat to indoor unit (see Figure 2 on this page and Figure 7 on page 14).
4. Ground unit at unit disconnect switch or to an earth ground.

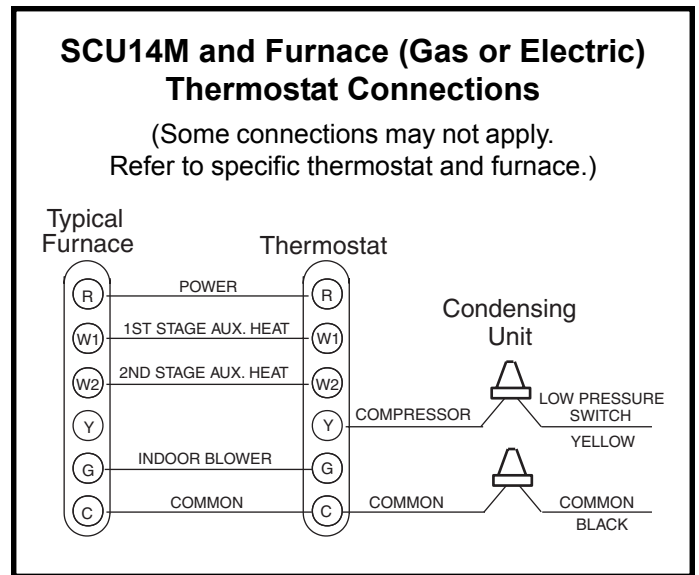

Figure 2

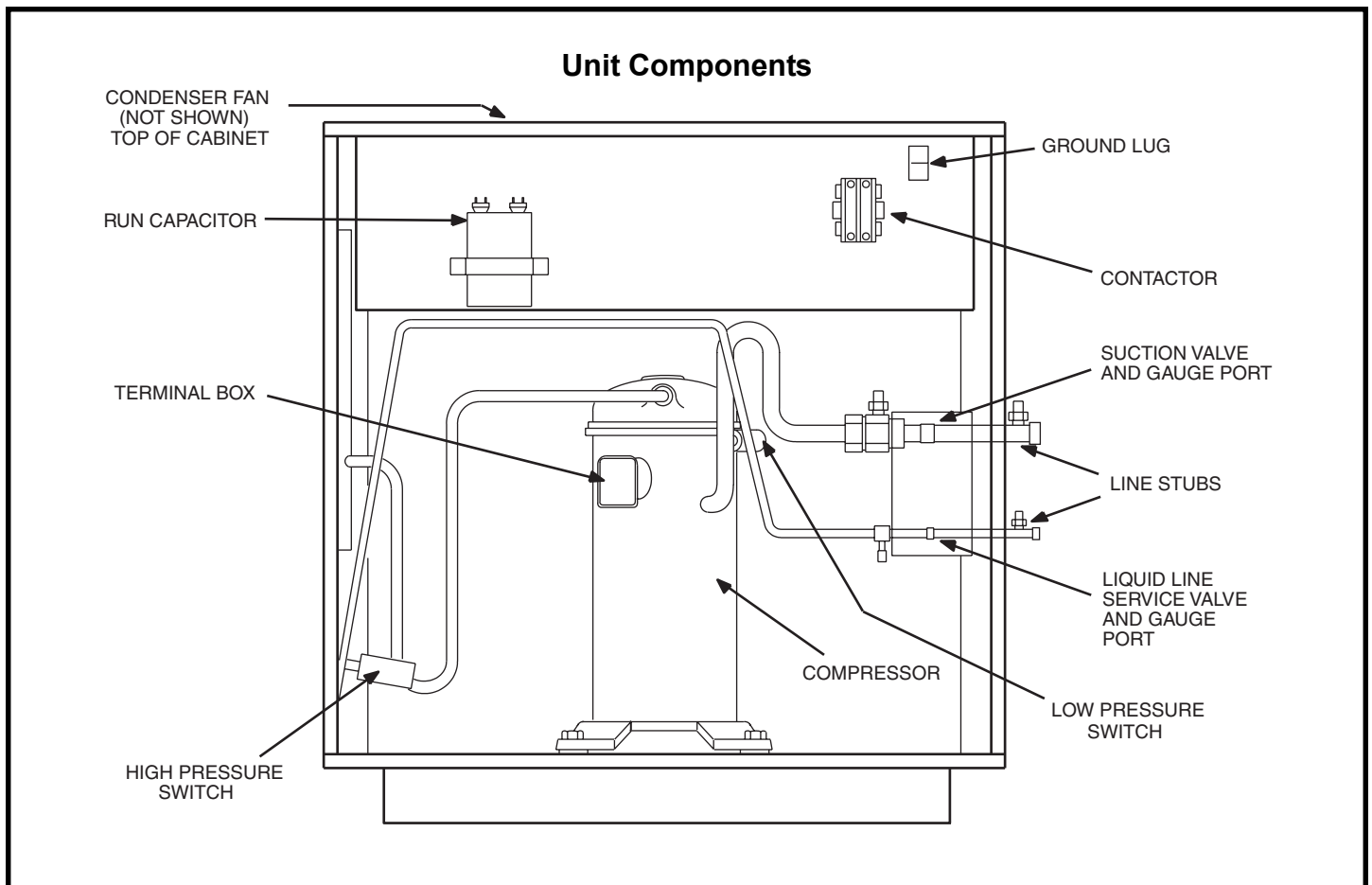

Figure 3

Plumbing

If the SCU14M unit is being installed with a new indoor coil and line set, the plumbing connections should be made as outlined in the section that follows. If an existing line set and/or indoor coil will be used to complete the system, refer to the section entitled **Flushing Existing Line Set and Indoor Coil** on page 6. **If this unit is being matched with an approved line set or indoor coil which was previously charged with R22 refrigerant, the line set and coil must be flushed prior to installation.**

Field refrigerant piping consists of liquid and suction lines from the condensing unit (sweat connections).

Plumbing Connections Using New Indoor Coil and Line Set

If refrigerant lines are to be routed through a wall, seal and isolate the opening so vibration is not transmitted to the building.

NOTE – Line length should be no greater than 50'. Use Table 2 to select line set diameters to ensure oil return to the compressor.

Refrigerant Line Kits		
Model	Liquid Line	Suction Line
SCU14M-024 SCU14M-030 SCU14M-036	3/8 in. (10mm)	3/4 in. (19mm)
SCU14M-042 SCU14M-048	3/8 in. (10mm)	7/8 in. (22mm)
SCU14M-060	3/8 in. (10mm)	1-1/8 in. (29mm)

Table 2

⚠ WARNING

Polyol ester (POE) oils used with R410A refrigerant absorb moisture very quickly. It is very important that the refrigerant system be kept closed as much as possible. **DO NOT** remove line set caps or service valve stub caps until ready to make connections.

Brazing Connection Procedure

1. The end of the refrigerant line must be cut square and its internal shape must remain round. The line must be free of nicks or dents and must be deburred (I.D. and O.D.).
2. Before making line set connections, use dry nitrogen to purge the refrigerant piping. This will help to prevent oxidation and the introduction of moisture into the system.
3. Use silver alloy brazing rods (5% or 6% silver alloy for copper-to-copper brazing or 45% silver alloy for copper-to-brass or copper-to-steel brazing) which are rated for use with R410A refrigerant. Wrap a wet cloth around the valve body and the copper tube stub. Remove light maroon washers from service valves and shield light maroon stickers to protect them during brazing. Braze the line set to the service valve.
4. Quench the joint with water or a wet cloth to prevent heat damage to the valve core and opening port. **The tube end must stay bottomed in the fitting during final assembly to ensure proper seating, sealing, and rigidity.**
5. Flush line set and evaporator if required (refer to **Flushing Existing Line Set and Indoor Coil** on page 6).
6. Install the provided thermal expansion valve (approved for use with R410A refrigerant) in the liquid line at the indoor coil. (See the **Installing Thermo Expansion Valve** section that follows.)
7. Install the provided filter drier (approved for use with R410A refrigerant) in the liquid line as close as possible to the expansion device. **Do not leave the drier uncapped for more than 10 – 15 minutes prior to brazing, evacuation, and leak testing.**

Installing Thermo Expansion Valve

⚠ WARNING

Before opening any system, make sure the pressure in the system is brought to and remains at atmospheric pressure. Failure to comply can result in system damage and/or personal injury.

1. Insert suction line splice between evaporator and suction line with the equalizer port pointing upwards. **To prevent plugging the equalizer line with oil, the equalizer port must be between a 10:00 and 2:00 position.**

2. Separate the distributor assembly and remove the piston orifice and used teflon seal. Insert nozzle end of the thermo expansion valve along with a new teflon seal into the distributor and tighten to 20 – 30 ft. lbs. Use backup wrench on all wrench flats. **Overtightening will crush the teflon seal and may cause a leak.**
3. Attach liquid line portion of distributor assembly along with new teflon seal to the inlet of the thermo expansion valve. Tighten to 20 – 30 ft. lbs. Use backup wrench on all wrench flats. **Overtightening will crush the teflon seal and may cause a leak.**
4. Connect the external equalizer line to the equalizer port on the suction line splice.
5. Strap the superheat sensing bulb to the suction header.

Flushing Existing Line Set and Indoor Coil

CAUTION

When flushing existing line set and/or indoor coil, be sure to empty all existing traps. Residual mineral oil can act as an insulator, preventing proper heat transfer. It can also clog the thermal expansion valve, reducing system performance and capacity. Failure to properly flush the system as explained in these instructions will void the warranty.

This procedure should not be performed on systems which contain contaminants, such as compressor burn out.

Required Equipment

The following equipment is needed to flush the existing line set and indoor coil: Two clean R22 recovery bottles, an oil-less recovery machine with a pump down feature,

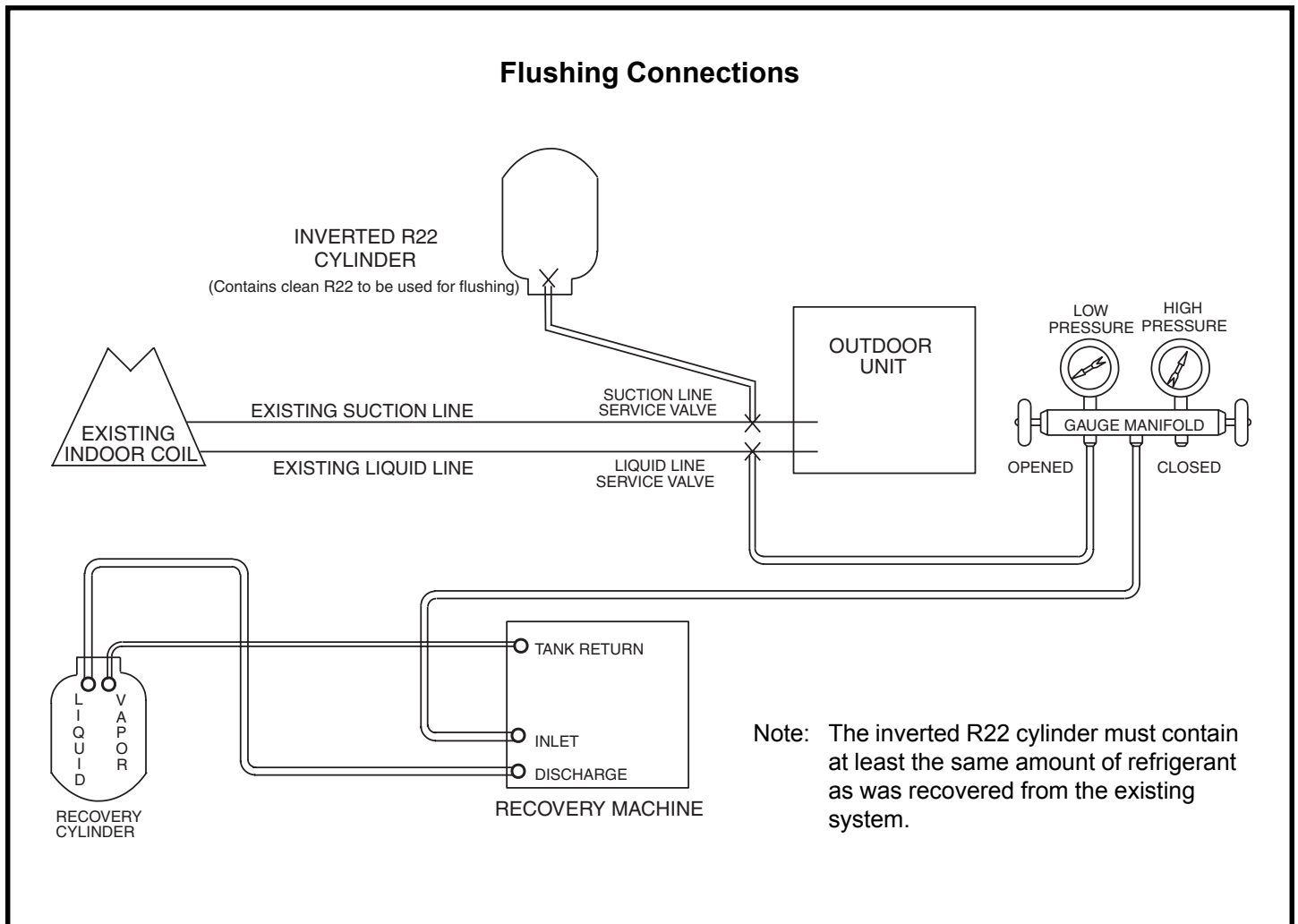

Figure 4

and two sets of gauges (one for use with R22 and one for use with R410A).

Flushing Procedure

IMPORTANT: The line set and/or indoor coil must be flushed with at least the same amount of refrigerant that previously charged the system. Check the charge in the flushing cylinder before flushing the unit.

1. Remove existing R22 refrigerant using the appropriate procedure.

*If the existing outdoor unit is not equipped with shutoff valves, or if the unit is not operational AND you plan to use the **existing** R22 refrigerant to flush the system:*

Disconnect all power to the existing outdoor unit. Connect the existing unit, a clean recovery cylinder, and the recovery machine according to the instructions provided with the recovery machine. Remove all R22 refrigerant from the existing system. Refer to the gauges after shutdown to confirm that the entire system is completely void of refrigerant. Disconnect the liquid and suction lines from the existing outdoor unit.

*If the existing outdoor unit is equipped with manual shutoff valves AND you plan to use **new** R22 refrigerant to flush the system:*

Start the existing R22 refrigerant system in cooling mode and close the liquid line valve. Pump all the existing R22 refrigerant back into the outdoor unit. (It may be necessary to bypass the low pressure switches to ensure complete refrigerant evacuation.) When the low side system pressures reach 0 psig, close the suction line valve. Disconnect all power to the existing outdoor unit. Refer to the gauges after shutdown to confirm that the valves are not allowing refrigerant to flow back into the low side of the system. Disconnect the liquid and vapor lines from the existing outdoor unit.

2. Remove the existing outdoor unit. Set the new R410A unit and follow the brazing connection procedure (see page 5) to make line set connections. **Do not install provided R410A check/expansion valve at this time.**

Make low voltage and line voltage connections to the new outdoor unit. **Do not turn on power to the unit or open the outdoor unit service valves at this time.**

3. Remove the existing refrigerant flow control orifice or thermal expansion valve before continuing with flushing procedures. The existing devices are not approved for use with R410A refrigerant and may

prevent proper flushing. Use a field-provided fitting to reconnect the lines.

4. Remove the pressure tap valve cores from the SCU14M unit's service valves. Connect an R22 cylinder with clean refrigerant to the suction service valve. Connect the R22 gauge set to the liquid line valve and connect a recovery machine with an empty recovery tank to the gauge set.
 5. Set the recovery machine for liquid recovery and start the recovery machine. Open the gauge set valves to allow the recovery machine to pull a vacuum on the existing system line set and indoor coil.
 6. Invert the cylinder of clean R22 and open its valve to allow liquid refrigerant to flow into the system through the suction line valve. Allow the refrigerant to pass from the cylinder and through the line set and the indoor coil before it enters the recovery machine.
 7. After all of the liquid refrigerant has been recovered, switch the recovery machine to vapor recovery so that all of the R22 vapor is recovered. Allow the recovery to pull a vacuum on the system.
- NOTE:** A single system flush should remove all of the mineral oil from the existing refrigerant lines and indoor coil. A second flushing may be done (using clean refrigerant) if insufficient amounts of mineral oil were removed during the first flush. **Each time the system is flushed, you must allow the recovery machine to pull a vacuum on the system at the end of the procedure.**
8. Close the valve on the inverted R22 cylinder and the gauge set valves. Pump the remaining refrigerant out of the recovery machine and turn the machine off.
 9. Use nitrogen to break the vacuum on the refrigerant lines and indoor coil before removing the recovery machine, gauges, and R22 refrigerant drum. Re-install pressure tap valve cores into the SCU14M service valves.
 10. Install the provided expansion valve (approved for use with R410A refrigerant) in the liquid line at the indoor coil.

Manifold Gauge Set

Manifold gauge sets used with systems charged with R410A refrigerant must be capable of handling the higher system operating pressures. The gauges should be rated for use with pressures 0 – 800 on the high side and a low side of 30" vacuum to 250 psi with dampened speed to 500 psi. Gauge hoses must be rated for use at up to 800 psi of pressure with a 4000 psi burst rating.

Liquid and Suction Line Service Valves

The liquid line and suction line service valves (Figures 5 and 6) and gauge ports are accessible from inside the unit, behind the access panel. The service ports are used for leak testing, evacuating, charging, and checking charge.

The valve is equipped with a service port. A schrader valve is factory installed. A service port cap is supplied to protect the schrader valve from contamination and serve as the primary leak seal.

To Access the Schrader Port:

1. Remove the access panel.
2. Remove the service port cap with an adjustable wrench.
3. Connect gauge to the service port.
4. When testing is completed, replace service port cap. Tighten finger tight, then an additional 1/6 turn.

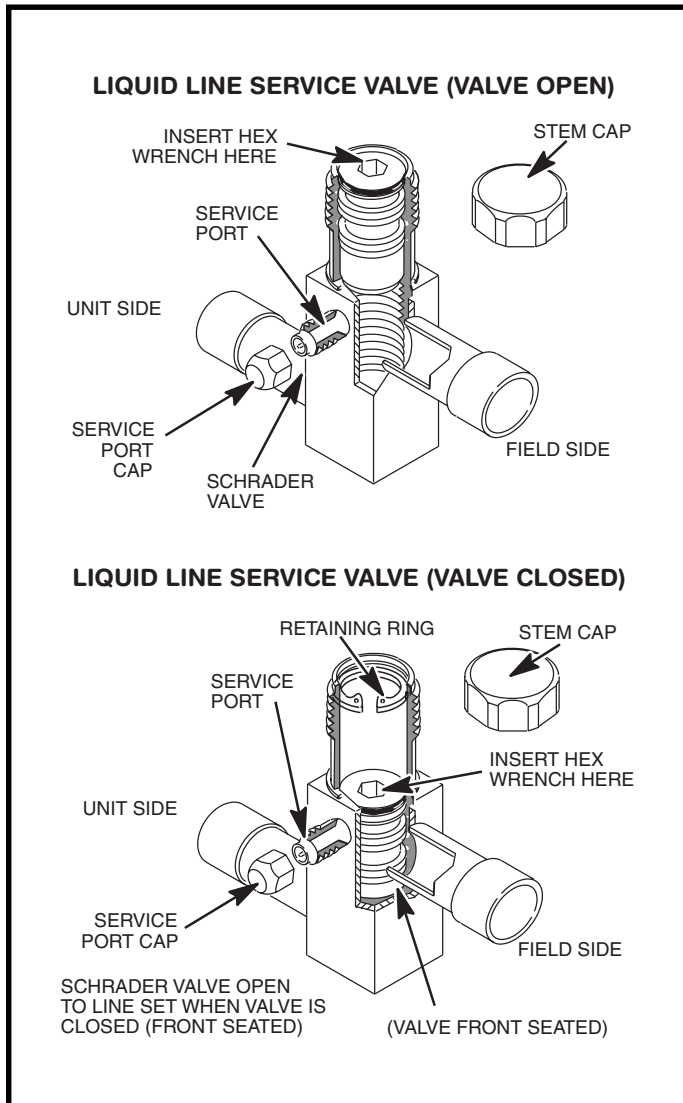

To Open Liquid or Suction Line Service Valve:

1. Remove stem cap with an adjustable wrench.
2. Use a service wrench with a hex-head extension to back the stem out counterclockwise until the valve stem just touches the retaining ring.
3. Replace the stem cap. Tighten finger tight, then tighten an additional 1/6 turn.

To Close Liquid or Suction Line Service Valve:

1. Remove the stem cap with an adjustable wrench.
2. Use a service wrench with a hex-head extension to turn the stem clockwise to seat the valve. Tighten it firmly.

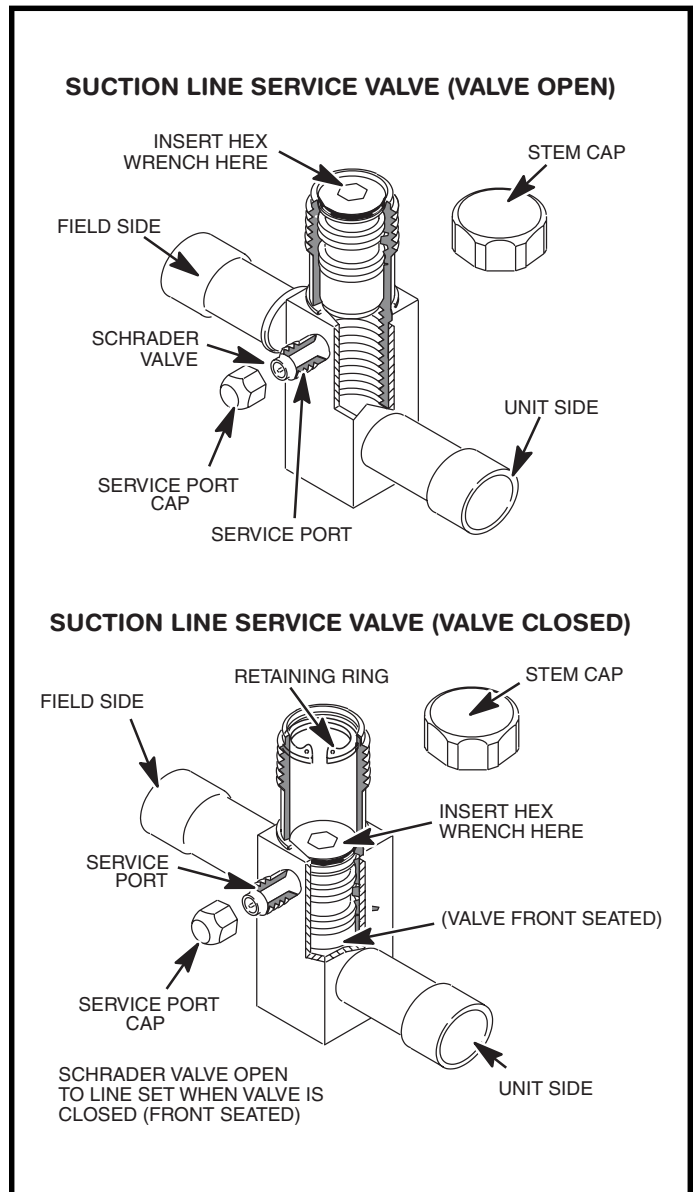

Figure 6

⚠ WARNING

Do not attempt to backseat this valve. Attempts to backseat this valve will cause snap ring to explode from valve body under pressure of refrigerant. Personal injury and unit damage will result.

3. Replace the stem cap. Tighten finger tight, then tighten an additional 1/6 turn.

Leak Testing

After the line set has been connected to the indoor and outdoor units, the line set connections and indoor unit must be checked for leaks.

⚠ WARNING

Refrigerant can be harmful if inhaled. Refrigerant must always be used and recovered responsibly. Incorrect or irresponsible use of refrigerant can result in personal injury or death.

⚠ WARNING

Never use oxygen to pressurize refrigeration or air conditioning systems. Oxygen will explode on contact with oil and could cause personal injury or death.

Using an Electronic Leak Detector

1. Connect the high pressure hose of the manifold gauge set to the suction valve service port. (Normally the high pressure hose is connected to the liquid line port; however, connecting it to the suction ports helps to protect the manifold gauge set from damage caused by high pressure.)
2. With both manifold valves closed, connect the cylinder of R410A refrigerant. Open the valve on the R410A cylinder (vapor only).
3. Open the high pressure side of the manifold to allow R410A into the line set and indoor unit. Weigh in a trace amount of R410A. (A trace amount is a maximum of 2 oz. of refrigerant or 3 lbs. pressure.) Close the valve on the R410A cylinder and the valve on the high pressure side of the manifold gauge set. Disconnect the R410A cylinder.

4. Connect a cylinder of nitrogen with a pressure regulating valve to the center port of the manifold gauge set. **When using high pressure gas such as nitrogen for this purpose, be sure to use a regulator that can control the pressure down to 1 or 2 psig.**
5. Adjust nitrogen pressure to 150 psig. Open the valve on the high side of the manifold gauge set to pressurize the line set and the indoor coil.
6. After a short period of time, open a refrigerant port to make sure that an adequate amount of refrigerant has been added for detection (refrigerant requirements will vary with lengths). Check all joints for leaks. Purge nitrogen and R410A mixture. Correct any leaks and recheck.

IMPORTANT: The leak detector must be capable of sensing HFC refrigerant.

Evacuation and Dehydration

Evacuating the system of non-condensables is critical for proper operation of the unit. Non-condensables are defined as any gas that will not condense under temperatures and pressures present during operation of an air conditioning system. Non-condensables and water vapor combine with refrigerant to produce substances that corrode copper piping and compressor parts.

1. Connect the manifold gauge set to the service valve ports as follows: low pressure gauge to suction line service valve and high pressure gauge to liquid line service valve.

IMPORTANT – Compliant scroll compressors (as with any refrigerant compressor) should never be used to evacuate a refrigeration or air conditioning system.

NOTE – A temperature vacuum gauge, mercury vacuum, or thermocouple gauge should be used. The usual bourdon tube gauges are inaccurate in the vacuum range.

2. Connect the vacuum pump (with vacuum gauge) to the center port of the manifold gauge set.
3. Open both manifold valves and start vacuum pump.
4. Evacuate the line set and indoor unit to an absolute pressure of 23mm (23,000 microns) of mercury (approximately 1 in. of mercury). During the early stages of evacuation, it is desirable to close the manifold gauge valve at least once to determine if there is a rapid rise in absolute pressure. A rapid rise in pressure indicates a relatively large leak. If this occurs, the leak testing procedure must be repeated.

NOTE – The term *absolute pressure* means the total actual pressure with a given volume or system, above

the absolute zero of pressure. Absolute pressure in a vacuum is equal to atmospheric pressure minus vacuum pressure.

- When the absolute pressure reaches 23mm of mercury, close the manifold gauge valves, turn off the vacuum pump, and disconnect the manifold gauge center port hose from the vacuum pump. Attach the manifold gauge center port hose to a nitrogen cylinder with pressure regulator set to 150 psig and purge the hose. Open the manifold gauge valves to break the vacuum in the line set and indoor unit. Close the manifold gauge valves.

⚠ WARNING

Do not use a compressor to evacuate a system. Avoid deep vacuum operation. Extremely low vacuums can cause internal arcing and compressor failure. Danger of equipment damage. Damage caused by deep vacuum operation will void warranty.

- Shut off the nitrogen cylinder and remove the manifold gauge hose from the cylinder. Open the manifold gauge valves to release the nitrogen from the line set and indoor unit.
- Reconnect the manifold gauge to the vacuum pump, turn the pump on, and continue to evacuate the line set and indoor unit until the absolute pressure does not rise above .5mm (500 microns) of mercury within a 20-minute period after shutting off the vacuum pump and closing the manifold gauge valves.
- When the absolute pressure requirement above has been met, disconnect the manifold hose from the vacuum pump and connect it to an upright cylinder of R410A refrigerant. Open the manifold gauge valves to break the vacuum in the line set and indoor unit. Close manifold gauge valves and shut off R410A cylinder and remove manifold gauge set.

START-UP

- Rotate fan to check for frozen bearings or binding.
- Inspect all factory and field-installed wiring for loose connections.
- Open liquid line and suction line service valves to release refrigerant charge (contained in condensing unit) into system. Replace and tighten caps. Use a back-up wrench on the suction and liquid valves when removing or replacing valve caps.
- To open suction valve, remove hex cap and turn valve stem fully open using an Allen (hex) wrench. To open

liquid valve, remove cap and turn valve stem until it is fully open.

NOTE: When replacing valve caps, the caps should be finger tight then tightened an additional 1/6 of a turn.

- Check voltage supply at the disconnect switch. the voltage must be within the range listed on the unit nameplate. If not, do not start equipment until the power company has been consulted and the voltage condition corrected.
- Set thermostat for cooling demand, turn on power to blower and close the condensing unit disconnect switch to start.
- Recheck unit voltage with unit running. Power must be within range shown on unit nameplate. Check amperage draw of unit. Refer to unit nameplate for correct running amps.

Charging

This system is charged with R410A refrigerant which operates at much higher pressures than R22. the expansion valve and liquid line drier provided with the unit are approved for use with R410A. Do not replace them with components designed for use with R22. This unit is NOT approved for use with coils which include metering orifices or capillary tubes.

Processing Procedure

Units are factory charged with the amount of R410A refrigerant indicated on the unit rating plate. This charge is based on a matching indoor coil and outdoor coil with 20' line set. For varying lengths of line set, refer to Table 3 for refrigerant charge adjustment.

⚠ IMPORTANT

Mineral oils are not compatible with R410A. If oil must be added, it must be a polyol ester oil.

Refrigerant Charge Adjustment

Liquid Line Set Diameter	Oz. per 5 ft. adjust from 20 ft. line set*
5/16 in.	2 oz. per 5 ft.
3/8 in.	3 oz. per 5 ft.

* If line length is **greater than 20 ft.**, add this amount. If line length is **less than 20 ft.**, remove this amount.

Table 3

The compressor is charged with sufficient polyol ester oil for line set lengths up to 50'. If line set lengths longer than 50' will be required, add 1 oz. of oil for every additional 10' of line set. Do not add any more than 7 oz. of oil. Copeland has approved Mobil EAL™ Arctic 22CC and ICI EMKARATE™ RL32CF for use with these compressors when oil must be added in the field.

The following procedure is intended as a general guide and is for use on expansion valve systems only. For best results, indoor temperature should be 70° – 80°F. Be sure to monitor system pressures while charging.

1. Record outdoor ambient temperature using a digital thermometer.
2. Attach high pressure gauge set and operate unit for several minutes to allow system pressures to stabilize.
3. Compare stabilized pressures with those provided in Table 4. Minor variations in these pressures may be expected due to differences in installations. Significant differences could mean that the system is not properly charged or that a problem exists with some other component in the system. Pressures higher than those listed indicate that the system is overcharged. Pressures lower than those listed indicate that the system is undercharged. A temperature/pressure chart for R410A refrigerant is provided in Table 5.

Verify adjusted charge using the approach method.

4. Outdoor temperature should be 60°F or above. For best results, use the same digital thermometer used to check outdoor ambient temperature to check liquid line temperature. Verify the unit charge

Temp. °F	Pressure Psig	Temp. °F	Pressure Psig	Temp. °F	Pressure Psig
32	100.8	74	214.0	116	396.0
33	102.9	75	217.4	117	401.3
34	105.0	76	220.9	118	406.7
35	107.1	77	224.4	119	412.2
36	109.2	78	228.0	120	417.7
37	111.4	79	231.6	121	423.2
38	113.6	80	235.3	122	428.8
39	115.8	81	239.0	123	434.5
40	118.0	82	242.7	124	440.2
41	120.3	83	246.5	125	445.9
42	122.6	84	250.3	126	451.8
43	125.0	85	254.1	127	457.6
44	127.3	86	258.0	128	463.5
45	129.7	87	262.0	129	469.5
46	132.2	88	266.0	130	475.6
47	134.6	89	270.0	131	481.6
48	137.1	90	274.1	132	487.8
49	139.6	91	278.2	133	494.0
50	142.2	92	282.3	134	500.2
51	144.8	93	286.5	135	506.5
52	147.4	94	290.8	136	512.9
53	150.1	95	295.1	137	519.3
54	152.8	96	299.4	138	525.8
55	155.5	97	303.8	139	532.4
56	158.2	98	308.2	140	539.0
57	161.0	99	312.7	141	545.6
58	163.9	100	317.2	142	552.3
59	166.7	101	321.8	143	559.1
60	169.6	102	326.4	144	565.9
61	172.6	103	331.0	145	572.8
62	175.5	104	335.7	146	579.8
63	178.5	105	340.5	147	586.8
64	181.6	106	345.3	148	593.8
65	184.3	107	350.1	149	601.0
66	187.7	108	355.0	150	608.1
67	190.9	109	360.0	151	615.4
68	194.1	110	365.0	152	622.7
69	197.3	111	370.0	153	630.1
70	200.6	112	375.1	154	637.5
71	203.9	113	380.2	155	645.0
72	207.2	114	385.4		
73	210.6	115	390.7		

Model	Line*	Outdoor Coil Entering Air Temp.				
		65°F	75°F	85°F	95°F	105°F
SCU14M-024	L	239	278	321	368	420
	S	129	131	133	135	138
SCU14M-030	L	232	271	314	360	412
	S	130	132	135	137	140
SCU14M-036	L	235	276	320	367	421
	S	128	130	132	134	137
SCU14M-042	L	241	282	326	373	424
	S	131	133	135	137	139
SCU14M-048	L	226	266	310	356	407
	S	130	132	135	137	139
SCU14M-060	L	240	279	321	368	418
	S	130	132	135	137	140

* L = Liquid S = Suction

Table 4

Table 5

using the approach method. The difference between the ambient and liquid temperatures should match values given in Table 6. Refrigerant must be added to lower approach temperature and removed to increase approach temperature. Loss of charge results in low capacity and efficiency.

Approach Temperatures	
Model	Approach Temperature Liquid Line Temp. - Outdoor Ambient °F
SCU14M-024	8 +/- 1
SCU14M-030	7 +/- 1
SCU14M-036	6 +/- 1
SCU14M-042	8 +/- 1
SCU14M-048	8 +/- 1
SCU14M-060	8 +/- 1

Table 6

- If the system is low on charge, R410A refrigerant must be added. Be aware of the R410A refrigerant cylinder. It will be light maroon colored. Refrigerant should be added through the suction valve in the liquid state. **Some R410A cylinders are equipped with a dip tube which allows liquid to be drawn from the bottom of the cylinder without turning the cylinder upside-down. The cylinder will be marked if it is equipped with a dip tube.**

OPERATION

Condensing unit and indoor blower cycle on demand from the room thermostat. When the thermostat blower switched in moved to the ON position, the indoor blower operates continuously.

High Pressure Switch

SCU14M units are equipped with a high pressure switch that is located in the discharge line of the compressor. The switch (SPST, manual reset, normally closed) removes power from the compressor when discharge pressure rises above factory setting at 640 ± 10 psi.

Low Pressure Switch

SCU14M units are also equipped with a low pressure switch that is located in the suction line of the compressor. The switch (SPST, auto-reset, normally closed) removes

power from the compressor when suction line pressure drops below factory setting at 40 ± 5 psi.

Filter Drier

A drier is shipped with each SCU14M unit. The drier must be field installed in the liquid line between the liquid line service valve and the expansion valve. **This drier must be installed to ensure a clean, moisture-free system.** A replacement drier is available through the local distributor.

MAINTENANCE

⚠ WARNING

Before performing maintenance operations on system, turn the electric power to unit OFF at disconnect switch(es). Unit may have multiple power supplies. Electrical shock could cause personal injury or death.

At the beginning of each cooling season, the system should be checked as follows:

- Clean and inspect condenser coil. Coil may be flushed with a water hose.
- Condenser fan motor is pre-lubricated and sealed. No further lubrication is needed.
- Visually inspect connecting lines and coils for evidence of oil leaks.
- Check wiring for loose connections.
- Check for correct voltage at unit (with unit operating).
- Check amp-draw condenser fan motor.

Unit nameplate _____ Actual _____

NOTE – If owner complains of insufficient cooling, the unit should be gauged and refrigerant charge checked. Refer to the **Charging** section on page 10.

Evaporator Coil

- Clean coil, if necessary.
- Check connecting lines and coils for evidence of oil leaks.
- Check condensate line and clean, if necessary.

Indoor Unit

1. Clean or change filters.
2. Adjust blower speed for cooling. The pressure drop over the coil should be measured to determine the correct blower CFM. Refer to the unit information service manual for pressure drop tables and procedure.
3. On belt drive blowers, check belt for wear and proper tension.
4. Check all wiring for loose connections.
5. Check for correct voltage at unit (with unit operating).
6. Check amp-draw on blower motor.

Unit nameplate _____ Actual _____

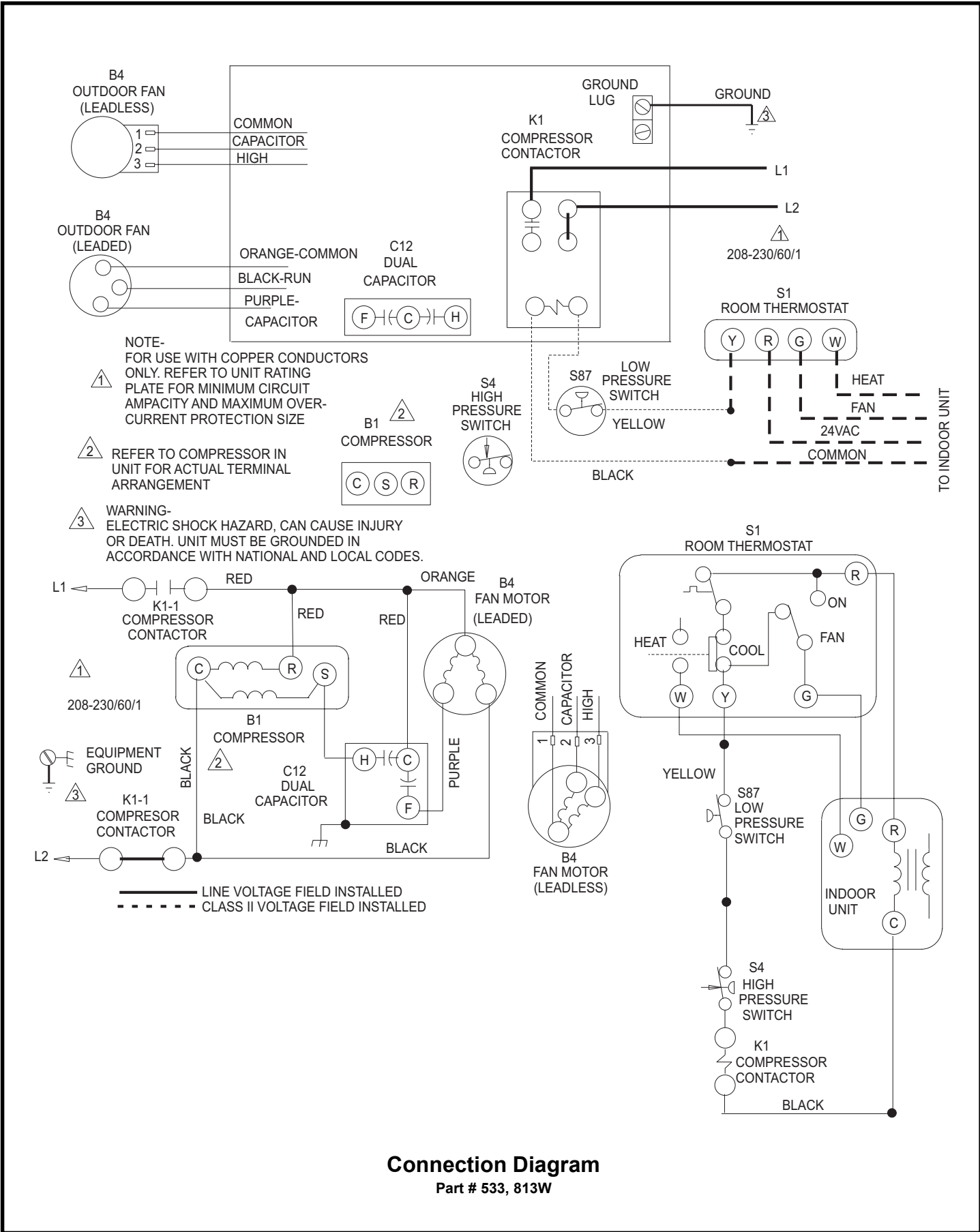

Connection Diagram
 Part # 533, 813W

Figure 7

Limited Warranty

August 1, 1997

This warranty gives you specific legal rights and you may have other rights which vary from state/province to state/province.

Warrantor: Armstrong Air Conditioning Inc., 421 Monroe St., Bellevue, OH 44811

Armstrong Air Conditioning Inc. products are available under the following names: Air Ease, Armstrong Air, American Aire, Concord

Subject to the limitations stated in this warranty, we warrant to the first buyer for use the residential heating, cooling or heat pump unit, when installed, operated and maintained as required by this warranty, to be free of defects in workmanship or material for a period of 5 years (1 year for commercial equipment) from the time of installation. We will replace any defective component without cost or expense to you except for the costs of delivery and labor for removal and replacement of the defective component.

The SCU 14 Series air conditioners carry a 10-year compressor warranty.

Warranty Begins

The warranty period begins when the installation is complete and the product is ready to operate. You must be able to verify this date whenever a warranty claim is made. Original bill of sale, installer's invoice or other similar document will suffice. If the beginning date cannot be verified, we will consider warranty coverage to begin 6 months after the date the product was shipped from our factory.

Limitations on Implied Warranties

Implied warranties of merchantability or, to the extent applicable, fitness for a particular purpose are limited to 5 years, the same duration as the basic limited written warranty provided herein. Some states/provinces do not allow limitations on how long an implied warranty of merchantability or fitness lasts, so the above limitations or exclusions may not apply to you.

Only Warranty

This written Limited Warranty is the only warranty made by the warrantor; this warranty is in lieu of and excludes all other warranties, express or implied. The warrantor does not authorize any person to provide any other warranty or to assume for it any further obligation in connection with the warranted product.

What is NOT Covered

1. Cabinets or cabinet pieces.
2. Normal maintenance items such as filters, fan belts, fuses or other consumable items.
3. Damage caused by misuse, failure to maintain properly, accidents or acts of God.
4. External wiring, piping, venting or attachment of accessory products not integral to our product, including without limitation, humidifier, air cleaner, vent damper, thermostat or other mechanical devices not manufactured by the warrantor.
5. Products that have been operated in a corrosive atmosphere where a concentration of acids, halogenated hydrocarbons or other corrosive elements causes deterioration to metal surfaces or integral components. NOTE: Operation in a corrosive atmosphere is considered abuse and voids this warranty.
6. Products that have NOT been installed in accordance with our published installation instructions, applicable local, state/provincial or national codes, ACCA published standards.
7. Products that have NOT been installed by competent, qualified installers.
8. Products that have been moved from their original place of installation.

Warranty on Replacement Components

Any replacement component furnished by us will assume the remaining (unused) portion of the Limited Warranty.

Consequential Damages

The warrantor shall not be responsible for any consequential damages caused by any defect in the product. Some state/provinces do not allow the exclusion or limitations of incidental or consequential damages, so the above limitation or exclusion may not apply to you.

NOTE: After the first year, in the event that a gas or oil heat exchanger is no longer being manufactured by the warrantor, the warrantor will allow a credit equal to the then current wholesale price of an equivalent heat exchanger towards the purchase of a new Armstrong gas or oil furnace.

This product must be installed, used and cared for in accordance with the instruction manual. You are responsible for required periodic maintenance or service, such as changing or cleaning of air filters and lubrication or cleaning of components. Failure to properly install, operate or maintain your unit voids this warranty.

Owner Record

Model # _____ Serial # _____ Installation Date _____

INSTALLED BY:

Dealer _____

Address _____

Telephone # _____ License # _____