

INSTALLATION INSTRUCTIONS FOR THE SENSOR AND AFTER-HOURS SWITCH KIT USED WITH L CONNECTION NETWORK

Shipping and Packing List

Package 1 of 1 contains:

- 1 - Sensor (A2) or After-Hours Switch (S56)
- 2 - Screws

IMPORTANT - Use 22AWG minimum, 1 twisted pair shielded cable (100% aluminum shield with drain wire, Teflon jacket). Lennox P/N's 94L63, 27M19, 68M25, and Belden type 88761 are equivalent.

⚠ WARNING

Personal injury, loss of life, or damage to property! Installation and service must be performed by a qualified installer or service agency. Improper installation, adjustment, alteration, service or maintenance can cause personal injury, loss of life, or damage to property.

Application

Either a zone - or return air sensor is required on each rooftop unit in an L Connection™ network. The L Connection network provides direct digital communication to a single or network of rooftop units. A PC or a network control panel (NCP) can then be used to monitor and/or control the system.

56L80 and 94L60 sensors contain a data port which can be wired to interface with the L Connection network. The data port does not have to be wired or in operation for the system to function; it is a monitoring and diagnostic feature.

56L80 zone sensor contains a warmer/cooler adjustment lever which allows a ± 1 degree setpoint shift. A DIP switch on the sensor base can be adjusted to increase the range to ± 4 degrees or limit the range to no adjustment.

An after hours switch is provided on 56L80 and 94L60 zone sensors. A separate after hours switch must be installed when this feature is desired on systems using a 56L81 return air sensor, a 94L61 zone sensor, or a 76M32 zone sensor.

Cat. No.	Features
56L80	Wall-mount; communication port; after hours override switch; warmer/cooler adjustment with options.
94L60	Wall-mount; communication port, after hours override switch.
94L61	Wall-mount.
56L81	Duct-mount; installed in return air.
76M32	Wall-mount; flush-mount; stainless steel.
56L16	After Hours Switch

Wall-Mount Sensor Location

Install sensor on a standard handy box or directly on wall. Locate sensor in conditioned space approximately 5 feet (1-1/2m) above the floor in an area with good air circulation at average temperature. Avoid locating the room thermostat where it might be affected by:

- drafts or dead spots behind doors and in corners
- hot or cold air from ducts
- radiant heat from sun or appliances
- concealed pipes and chimneys

Zone Sensors - 56L80, 94L60, 94L61

1. Route cable from the unit controller to an appropriate location in the conditioned space. Make wire connections to unit as shown in figure 1.

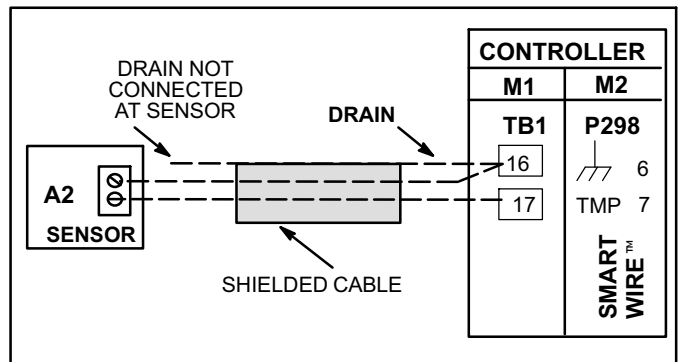

Figure 1. Sensor Wiring



- Loosen screws and remove sensor cover. Turn set screws clockwise on 56L80 and 94L60. See figures 2 and 3.

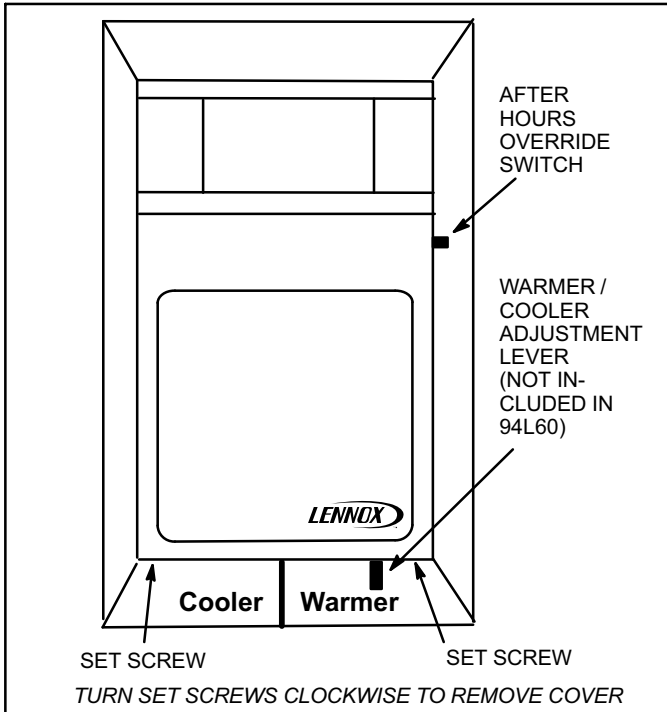

Figure 2. Zone Sensor - 56L80 and 94L60

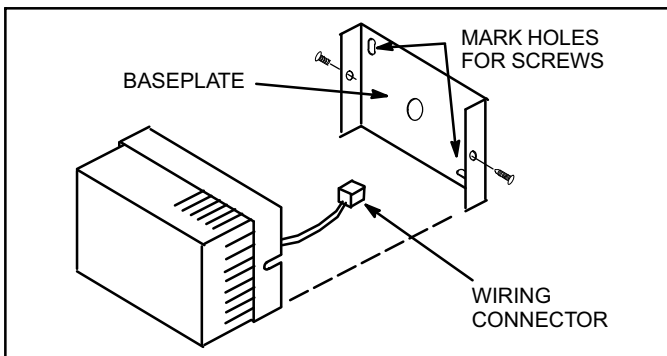

Figure 3. Zone Sensor - 94L61

- Center opening in baseplate or over opening in wall.
- Mark holes for screws. See figure 3 or 4. Remove baseplate and drill holes.
- Insert wall anchors (field provided) and align baseplate over opening in wall. Pull wiring through opening in baseplate. Secure baseplate to wall with screws.
- Connect wiring to sensor as shown in figure 1. When use of the data port is desired on 56L80 and 94L60 sensors, make communication wire connections as shown in figure 5.
- 56L80 Only** - The sensor contains a warmer/cooler adjustment lever which allows a $\pm 1^\circ\text{F}$ setpoint shift. A DIP switch on the sensor base can be adjusted to increase the range to $\pm 4^\circ\text{F}$ or limit the range to no adjustment. See figure 4 for DIP switch location and figure 6 to change the adjustment range.

- Replace zone sensor cover and either tighten side screws or turn set screws counterclockwise to secure cover in place.

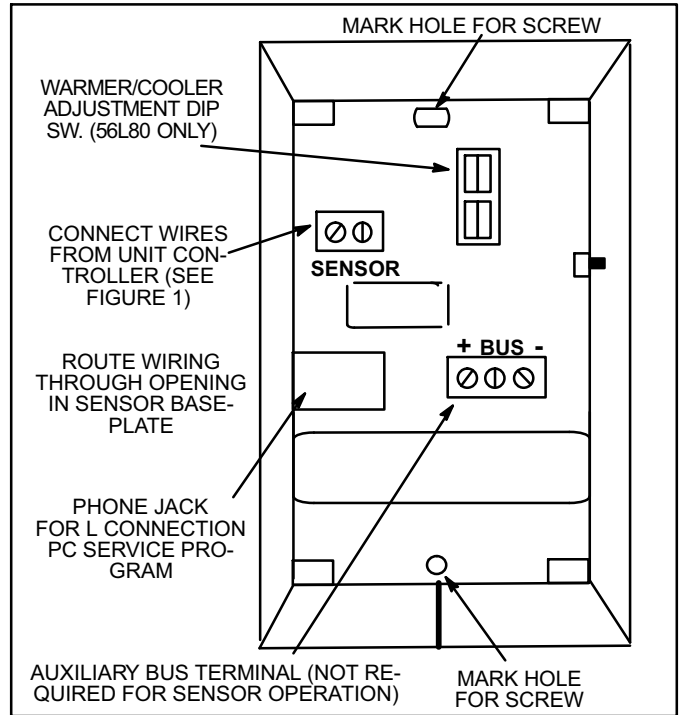

Figure 4. Zone Sensor - 56L80 and 94L60

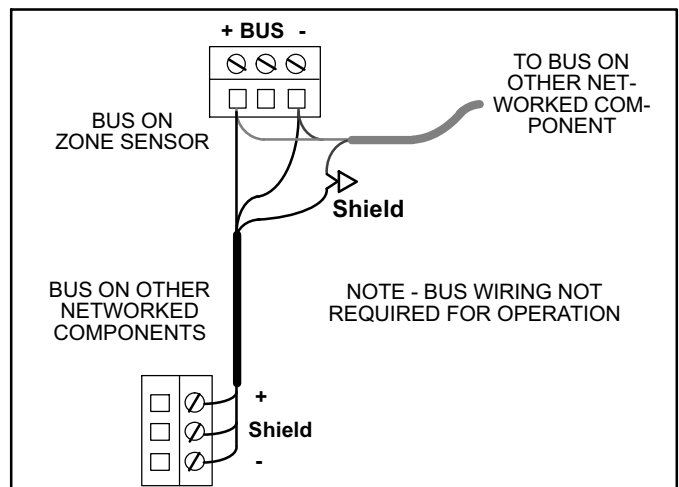

Figure 5. Communication Wiring - L Connection (Available On 56L80 and 94L60 Sensors Only)

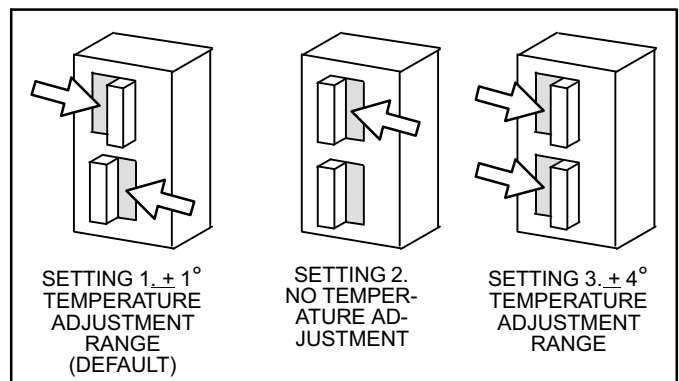

Figure 6. Warmer/Cooler Adjustment Range

Zone Sensor - 76M32

1. Route cable from unit controller to an appropriate location in the conditioned space. Make wire connections to unit as shown in figure 1 (see Page 1).
2. Make wire connections to sensor with wire nuts (sensor has leads instead of a terminal block).
3. Secure sensor to wall with screws provided.

Return Air Sensor - 56L81

1. Open unit filter section and remove knock-out labeled "A2". See figure 7.
2. Insert return air sensor probe through hole and secure in place with two screws provided.
3. Connect return air sensor leads to wires from J62 terminals 1 and 3.
4. Connect jumper wires between rooftop unit TB1 terminals 5 and 17 and TB1 terminals 14 and 16.

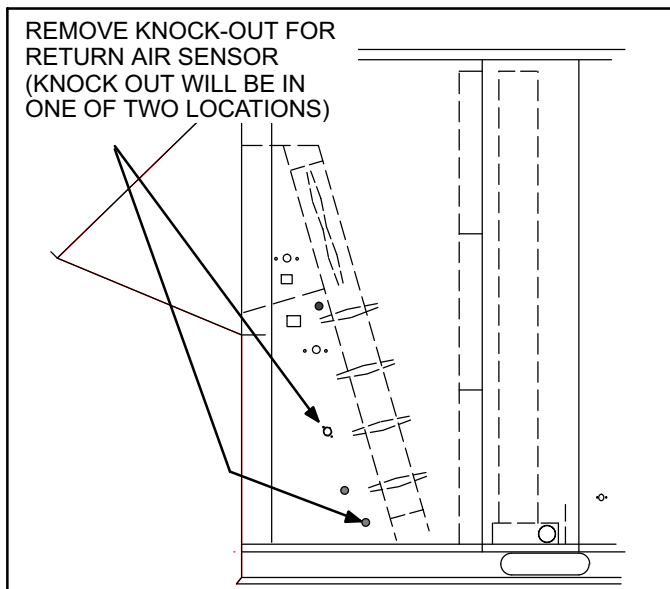

Figure 7. Unit Filter Section

After-Hours Override Switch S56 - 56L16

IMPORTANT - This section refers to 56L16 only. The after hours override switch located on the Zone Sensor (A2) requires no additional installation or wiring.

Connect standard 24V thermostat wires (one pair 20 AWG minimum) from unit controller (M1, TB1-16 & 17; M2, P298-6 & 7). Route the wires to location where switch will be installed.

1. Center switch over opening in wall and mark holes for screws.
2. Connect wires to switch pigtails.
3. Secure switch to wall using two screws provided.
4. Connect jumper wires between rooftop unit TB1 terminals 5 and 17 and TB1 terminals 14 and 16.

Standard Sensors Used For Averaging

Four sensors may be used to get an average temperature reading. Use ONLY the 94L61, 56L81, 76M32 sensors and the 56L16 after hours override switch. Wire sensors as shown in figure 8.

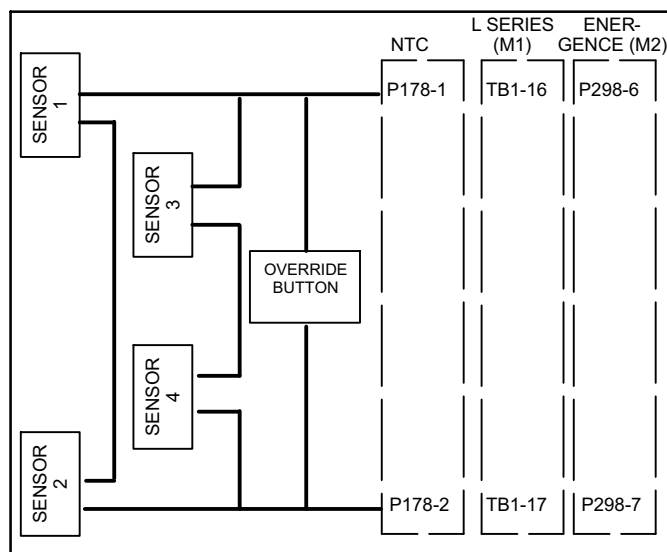

Figure 8. Wiring Standard Sensors for Averaging

