



© 2006 Lennox Industries Inc.
Dallas, Texas, USA

GAS UNITS
KITS AND ACCESSORIES

Technical Publications
Litho U.S.A.

505,172M
08/06

**IGNITION CONTROL
REPLACEMENT KIT**

**INSTALLATION INSTRUCTIONS FOR
IGNITION CONTROL CONVERSION KIT LB-91097C (17W82)
USED WHEN REPLACING AN EGC-1 OR EGC-2 CONTROL WITH AN EGC-1**

⚠ WARNING

This conversion kit is to be installed by a qualified Lennox service technician or other qualified agency in accordance with the manufacturer's instructions, all codes and requirements of the authority having jurisdiction in the USA, and the requirements of the CSA-B149 installation codes in Canada. If the information in these instructions is not followed exactly, a fire or explosion may result causing property damage, personal injury or loss of life. The qualified agency performing this work assumes responsibility for this conversion.

**ELECTROSTATIC DISCHARGE (ESD)
Precautions and Procedures**

⚠ CAUTION

Electrostatic discharge can affect electronic components. Take precautions during furnace installation and service to protect the furnace's electronic controls. Precautions will help to avoid control exposure to electrostatic discharge by putting the furnace, the control and the technician at the same electrostatic potential. Neutralize electrostatic charge by touching hand and all tools on an unpainted unit surface, such as the gas valve or blower deck, before performing any service procedure.

Shipping and Packing List

Package 1 of 1 contains:

- 1 - Replacement ignition control (EGC-1)
- 1 - Continuous fan jumper (used with EGC-2 units converted to EGC-1)

NOTE - This kit contains components for converting ignition controls for two different series of units. Use only the components required for the particular unit(s) being converted.

Shipping Damage

Check all components for shipping damage. Consult last carrier immediately if damage is found.

Application

This kit is used when replacing either an EGC-1 or an EGC-2 control with an EGC-1 control in any Lennox unit in which they are used.

Installation - EGC-1 Replaced by EGC-1

⚠ WARNING

Before installing or servicing unit, be sure ALL power to unit is OFF. More than one disconnect switch may be present. Electrical shock can cause personal injury or death!

- 1 - Shut off gas supply and disconnect electrical power from the unit.
- 2 - Remove access door.
- 3 - Mark and disconnect all wires from control board. Disconnect harness plug.
- 4 - Remove control board.
- 5 - Snap-mount the replacement control board, positioned as the existing control board.
- 6 - Reconnect wires and harness plug to control board. **The kit-provided jumper is not used.** Install wire ties as required.

IMPORTANT - DO NOT INCLUDE IGNITION LEAD IN ANY GROUP OF BUNDLED WIRES. ROUTE IGNITION LEAD SEPARATELY.

Installation - EGC-2 Replaced by EGC-1

⚠ WARNING

Before installing or servicing unit, be sure ALL power to unit is OFF. More than one disconnect switch may be present. Electrical shock can cause personal injury or death!

- 1 - Shut off gas supply and disconnect electrical power from the unit.
- 2 - Remove access door.
- 3 - Mark and disconnect all wires from control board. Disconnect harness plug.
- 4 - Remove control board.

**EGC-2 CONTROL REPLACED WITH EGC-1
WIRING OF BLOWER SPEED TAPS TO EGC-1 CONTROL BOARD
WHEN USING CONTINUOUS FAN JUMPER**

CONTINUOUS FAN JUMPER
(KIT-PROVIDED AND FIELD-INSTALLED)
Do not install jumper if continuous low speed is installed, either at control board ACB LOW terminal or to a separate circuit controlled by terminal G of the thermostat.

----- EXISTING WIRES RECONNECTED
——— EXISTING WIRE
————— REPLACEMENT WIRE

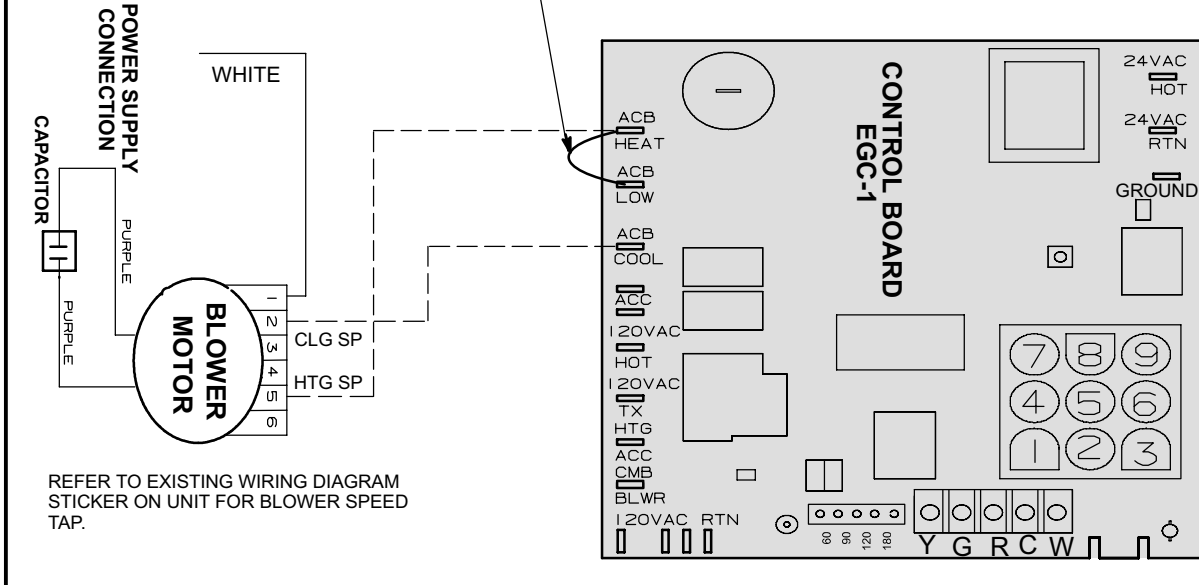

FIGURE 1

- 5 - Snap-mount the replacement control board, positioned as the existing control board.
- 6 - Reconnect wires and harness plug to control board. **For kit-provided jumper usage see step 7.** Install wire ties as required.

IMPORTANT - DO NOT INCLUDE IGNITION LEAD IN ANY GROUP OF BUNDLED WIRES. ROUTE IGNITION LEAD SEPARATELY.

- 7 - Blower Speed and Continuous Fan Connections:
Existing units with continuous low speed fan operation:
Do not install provided continuous fan jumper as shown in figure 1 and do not change existing low speed tap connection. Make the ACB HEAT and ACB COOL connections as shown.
Existing units with no continuous low speed fan operation:
Connect provided continuous fan jumper between control board terminals ACB HEAT and ACB LOW to obtain continuous fan operation on the heating speed when thermostat is set to FAN ON and there is no heating or cooling demand. Make the ACB HEAT and ACB COOL connections as shown in figure 1.
Warning - Do not install jumper if continuous low speed is installed, either at control board ACB LOW terminal or to a separate circuit controlled by terminal G of the thermostat. Damage to the control board and/or blower motor may result.

EGC-1 Control Board Operation

EGC-1 Integrated Blower and Ignition Control Board

The EGC-1 control board controls blower operation and fan off timings, allows for thermostat connections, controls ignition and provides two diagnostic LEDs with a memory recall button. To interpret the LEDs, see the diagnostic codes section near the end of these instructions. To check operation sequence refer to the flow charts at the end of this instruction.

Blower Speed / Timing Adjustments

Important - Turn electrical power off before making any adjustments.

Continuous Speed

Systems using a cooling thermostat subbase may operate continuous blower through the Fan-ON switch of the thermostat. For continuous blower with a system without a cooling subbase, a toggle switch must be installed between the "R" and "G" of unit thermostat connections. Refer to existing unit wiring diagram sticker for factory connected blower speed taps.

EGC-2 controls replaced by EGC-1

Some units may have existing continuous low speed fan connected independently of the control board. If this is the case, do not connect continuous fan jumper. If this is not the case, install continuous fan jumper as outlined in step 7 of EGC-2 TO EGC-1 installation section to obtain continuous blower operation on the heating speed.

Warning - Do not install jumper if continuous low speed is installed, either at control board ACB terminal or to a separate circuit controlled by terminal G of the thermostat. Damage to the control board and/or blower motor may result.

EGC-1 controls replaced by EGC-1

The blower will operate continuously on low speed when connected to the control board as previously installed.

Fan On and Off timings

The fan on time of 45 seconds is not adjustable. Fan off time (time that the blower operates after the heating demand has been satisfied) can be adjusted by moving the jumper on the integrated control board. The replacement integrated control is shipped with a factory fan off setting of 180 seconds. Fan off time will affect comfort and is adjustable to satisfy individual applications. See figure 2.

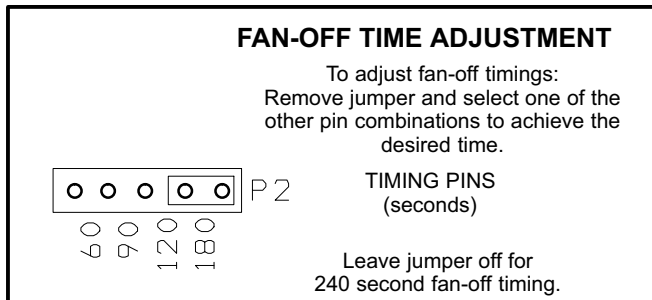

FIGURE 2

Start-Up

BEFORE LIGHTING smell all around the appliance area for gas. Be sure to smell next to the floor because some types of gas are heavier than air and will settle on the floor.

Unit may be equipped with either a gas control knob or lever. Use only your hand to push in or turn the gas control knob or move the gas control lever. Never use tools. If the knob will not push in or turn or if lever will not move by hand, do not try to repair it, call a qualified service technician. Force or attempted repair may result in a fire or explosion.

To place unit in operation

- 1 - Make sure thermostat is set below room temperature and power is turned off to unit.
- 2 - This appliance is equipped with an ignition device which automatically lights the pilot burner. **DO NOT** try to light the pilot burner by hand.
- 3 - On units with a gas valve control knob, turn knob to **OFF**. On units with a gas valve control lever, switch lever to **OFF**. Do not force.
- 4 - Wait 15 minutes to clear out any gas. If you then smell gas, immediately call your gas supplier from a neighbor's phone. Follow the gas supplier's instructions. If you do not smell gas go to next step.
- 5 - On units with a gas valve control knob, turn knob to **ON**. On units with a gas valve control lever, switch lever to **ON**. Do not force.
- 6 - Turn on all electrical power to unit.
- 7 - Set thermostat to above room temperature.
- 8 - Check gas line supply pressure with unit operating. The minimum pressure as shown on the name rating plate must be available. Then check and adjust manifold pressure to the value indicated on the unit rating plate.
- 9 - Set heat anticipator to 0.65 for Honeywell gas valve and 0.50 for WhiteRodgers gas valve.
- 10 - Run unit through a minimum of three complete cycles to check for normal operation.
- 11 - Set thermostat to desired setting.
- 12 - Replace access panel.

EGC-1 Diagnostic Codes

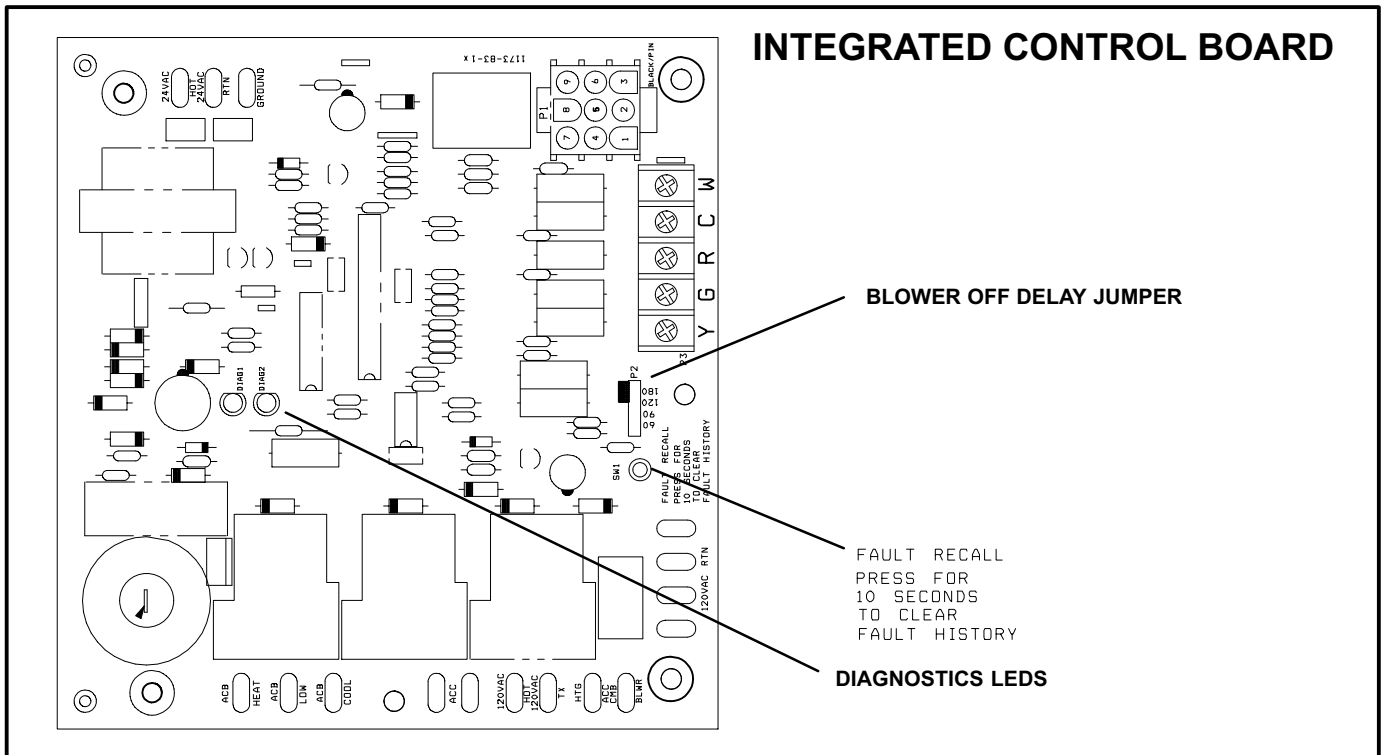

DSI BOARD DIAGNOSTIC PATTERNS	MODE INDICATION	REMEDY
DIAG 1 Flashing Together DIAG 2 Flashing Together	Normal Operation	None. Slow flashing LED signifies normal operation. Fast flashing LED indicates a heating demand.
DIAG 1 Flashing DIAG 2 On	Limit Switch Open	This LED pattern indicates that either the primary or secondary limit switch has opened. Both switches are auto-reset.
DIAG 1 Off DIAG 2 Flashing	Pressure Switch Open	This LED pattern indicates that the pressure switch opened during operation due to reduced flow of combustion products or a blocked condensate drain.
DIAG 1 Flashing Alternately DIAG 2 Flashing Alternately	Watchguard	The system is in Watchguard mode. Burners have failed to ignite.
DIAG 1 Flashing DIAG 2 Off	Flame Failure	This LED pattern indicates that a flame was sensed without power to the gas valve.
DIAG 1 On DIAG 2 Flashing	Flame Roll-Out	This LED pattern indicates that the flame roll-out switch has opened. Check continuity of switch and for blockage in heat exchanger. Manually reset switch.
DIAG 1 Continuously On DIAG 2 Continuously On	Control Board Failure	Remove power to reset control. Run cycle. Check control wiring and replace the EGC-1 control board, if necessary.

HEATING SEQUENCE OF OPERATION

NORMAL HEATING MODE

ABNORMAL HEATING MODE

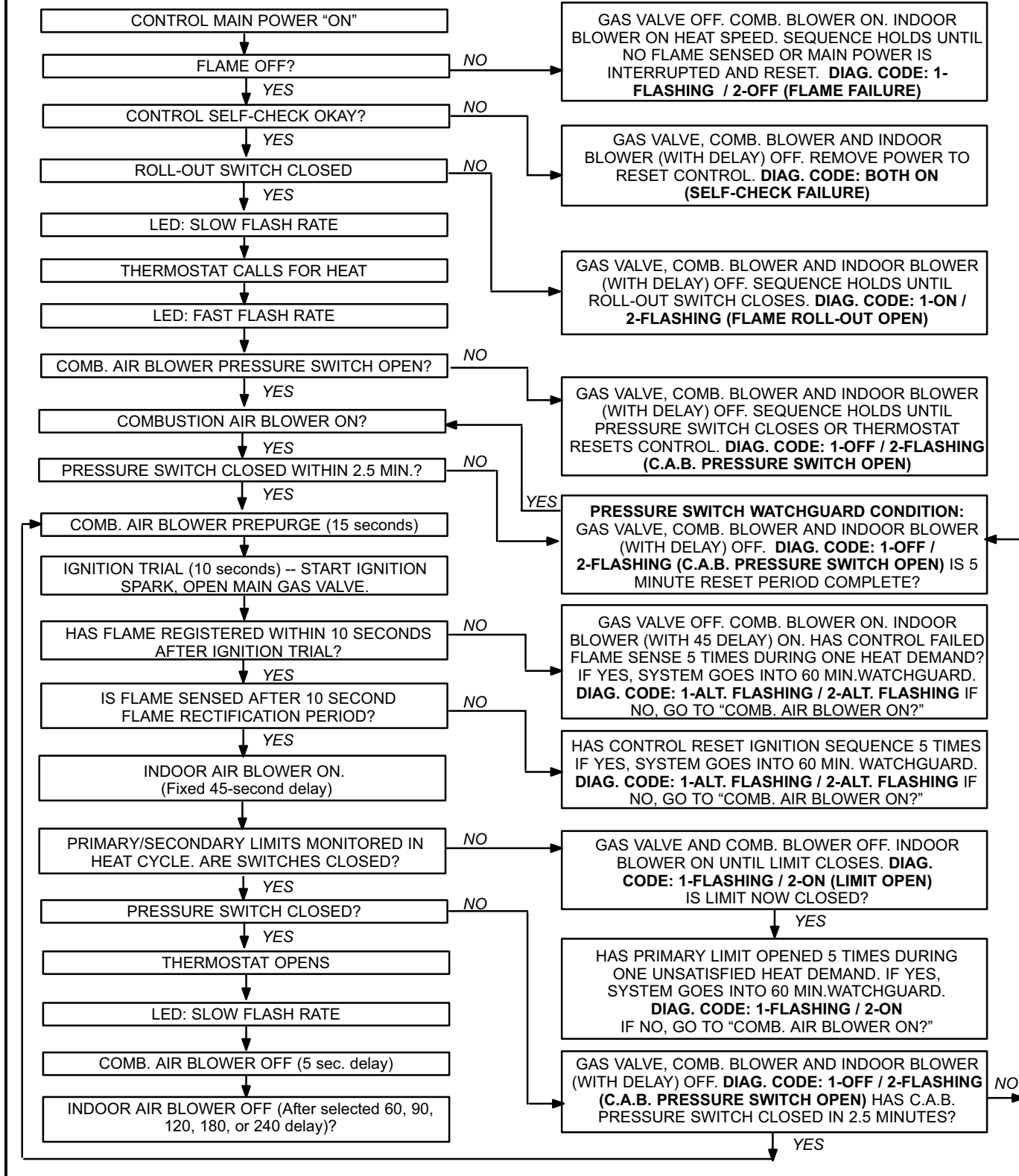

COOLING SEQUENCE OF OPERATION

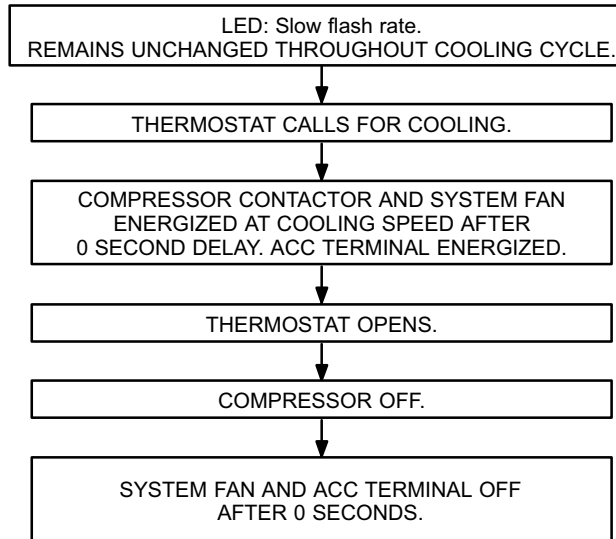

MANUAL FAN SEQUENCE OF OPERATION

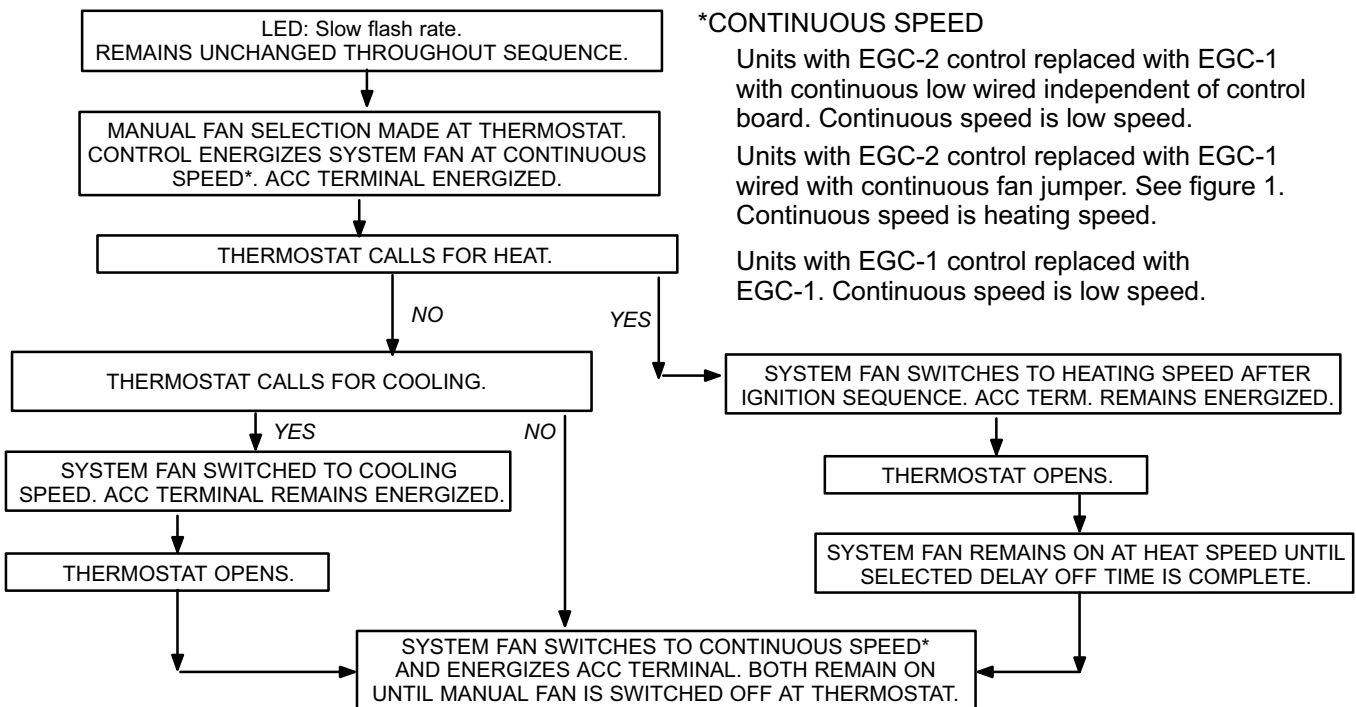

*CONTINUOUS SPEED

Units with EGC-2 control replaced with EGC-1 with continuous low wired independent of control board. Continuous speed is low speed.

Units with EGC-2 control replaced with EGC-1 wired with continuous fan jumper. See figure 1. Continuous speed is heating speed.

Units with EGC-1 control replaced with EGC-1. Continuous speed is low speed.