



HARDWIRING KIT

INSTALLATION INSTRUCTION FOR HARDWIRING KITS (Y0627 AND Y0628) USED WITH PUREAIR® AIR PURIFICATION SYSTEMS PCO14-23, PCO16-28 AND PCO20-28

**RETAIN THESE INSTRUCTIONS
FOR FUTURE REFERENCE**

Shipping and Packing List

Package 1 of 1 contains the following:

- 1 — PCO access door assembly
- 2 — #8-18x1" SDST Screws

Check equipment for shipping damage. If you find any damage, immediately contact the last carrier.

Application

These hardwiring kits are used in applications that require a direct power connection due to local codes. The kit catalog number for each model is as follows:

Model Number	Catalog Number
PCO14-23	Y0627
PCO16-28	Y0628
PCO20-28	Y0627

Installation

! WARNING

Risk of property damage, injury, or death.
Installation, adjustments, alternations, service and maintenance must be performed by a qualified installer or service agency.

! WARNING



Electric Shock Hazard.
Can cause injury or death.
Disconnect all electrical power supplies before servicing. Access panels must be in place during appliance operation.

! CAUTION

Sharp edges hazard
Sharp edges can cause injuries.
Use protective gloves when grasping equipment edges.

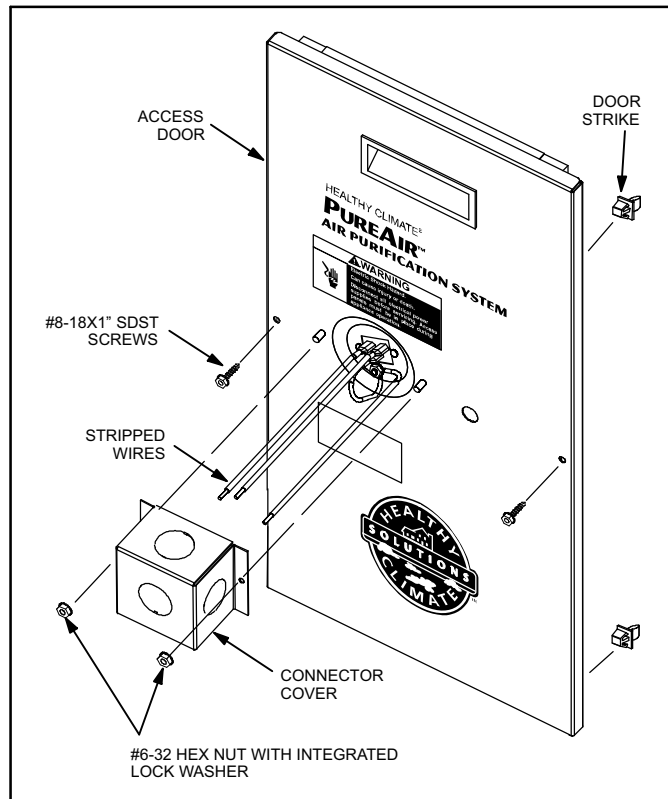

Figure 1. Kit Components

1. Remove access door from shipping container.
2. Remove the two #6-32 hex machine screw nuts with integrated lock washer from the connector cover on the new access door.
3. Select the desired 7/8" knockout location as illustrated in figure 2.

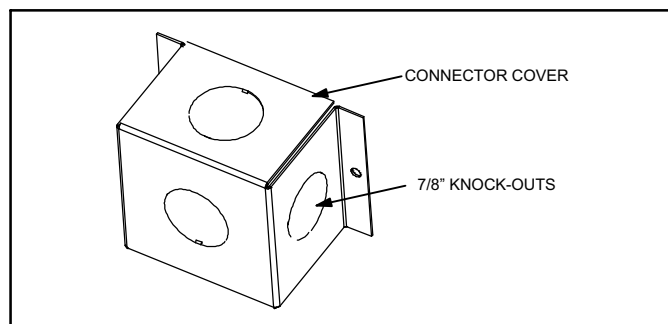

Figure 2. Knock-Out Locations

NOTE - Flexible electrical conduit must be used to make electrical connections to door connector cover. The door is intended to be removed for regular unit maintenance without removing electrical conduit.



4. Connect the field wires per figure 3 to the provided wires. Installation must conform with all local and national codes. Unit may be wired for 120VAC or 230VAC single- phase, 60Hz operation without any changes to internal components or wiring. Use minimum 75°C supply conductors
5. Reinstall the #6-32 hex machine screw nuts with integrated lock washer to secure the connector cover to the access door.
6. Remove the old access door and power cord (if connected) from the PCO unit and discard.
7. Install new access door on the PCO unit. Press access door until door strikes snap into place.

8. Secure door into place using the two provided #8-18x1" SDST screws. DO NOT over-tight screws or access door will deform.

NOTE - When attaching the new access door to the PCO unit, the 320 IEC jack on the back side of the access door will align with the 320 IEC plug on the front side of the PCO cabinet.

Replacement Part		
Models	Part Number	Description
All	X9541	PCO Access Door Strikes (4 each)

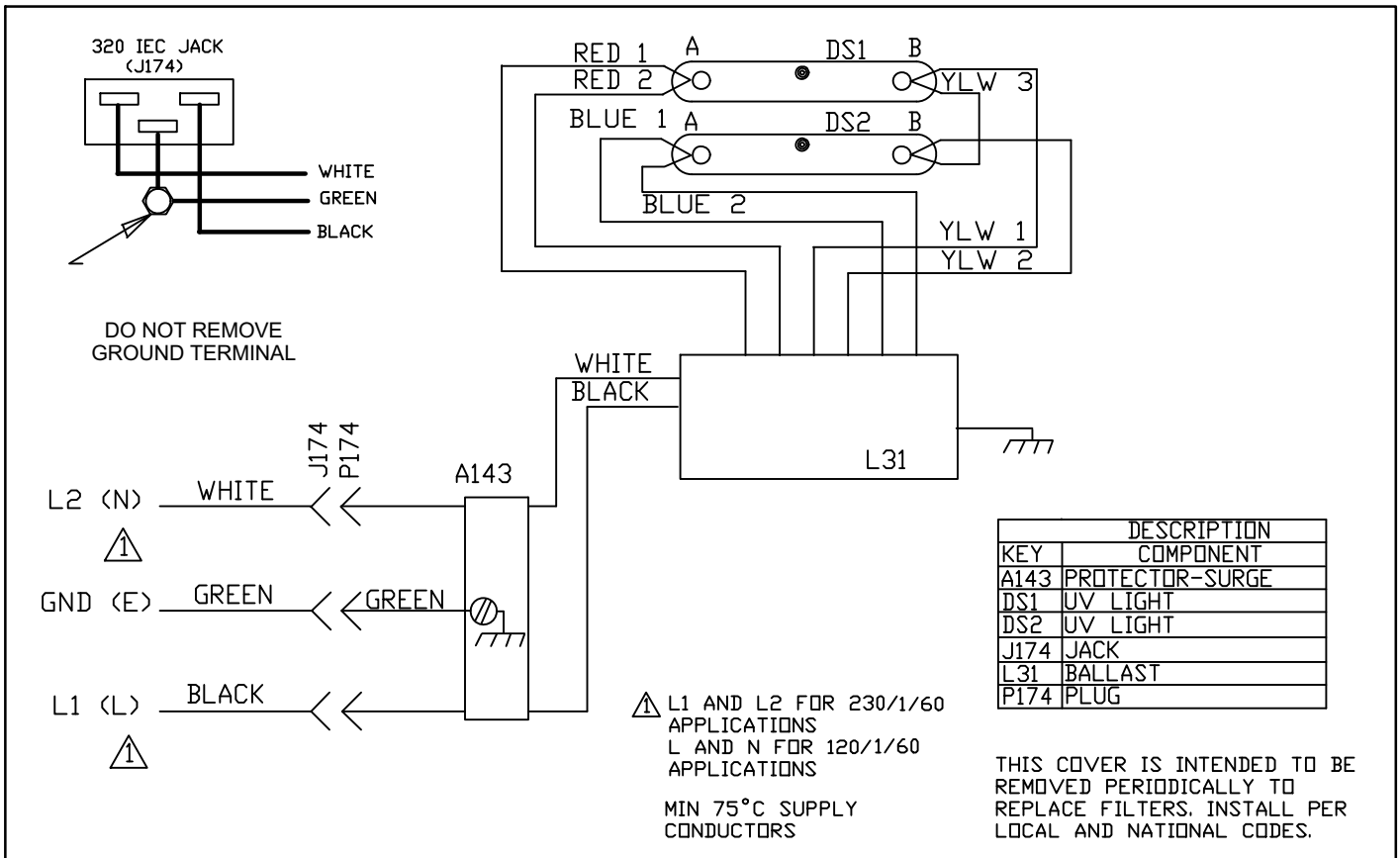

Figure 3. Wiring Diagram