

GAS KITS AND ACCESSORIES

506133-02
8/2017
Supersedes 506133-01

GAS CHANGEOVER KIT

INSTALLATION INSTRUCTIONS FOR NATURAL TO REGULATED LP/PROPANE GAS CHANGEOVER KIT (45L85 / 165296401) USED WITH 100,000, 125,000 AND 150,000 BTUH UNIT HEATERS

⚠ WARNING

This conversion kit is to be installed by a licensed professional service technician (or equivalent) or other qualified agency in accordance with the manufacturer's instructions, all codes and requirements of the authority having jurisdiction in the USA, and the requirements of the CSA-B149 installation codes in Canada. If the information in these instructions is not followed exactly, a fire or explosion may result causing property damage, personal injury or loss of life. The qualified agency performing this work assumes responsibility for this conversion.

Shipping and Packing List

Package 1 of 1 contains:

- 1 - Brass adapter
- 6 - Tapered burner orifices #53 (.0595") 1/8" NPT
- 1 - Honeywell VR8205 series gas valve conversion kit
- 1 - White Rodgers 36E/G series gas valve conversion kit
- 2 - Unit conversion stickers
- 1 - Pressure switch
- 1 - Blue wire c/w terminals
- 1 - 1/8" X 1-1/2" BIP nipple
- 1 - 1/8" X 2-1/2" BIP nipple
- 1 - 1/8" X 90° BIP elbow
- 6 - Turbulator assemblies
- 1 - Retainer
- 3 - 18 X 1/2 SDST Screws

Application

The natural to regulated LP/propane gas changeover kit, 45L85 / LB-85397A / 165296401, is used on LF24 / SEP-100, LF24-125, and LF24-150 unit heaters equipped with the Honeywell VR8205 series gas valve or White Rodgers 36E/G series gas valve.

⚠ WARNING

Danger of explosion.

There are circumstances in which odorant used with LP/propane gas can lose its scent. In case of a leak, LP/propane gas will settle close to the floor and may be difficult to smell. An LP/propane leak detector should be installed in all LP applications.

⚠ WARNING

Improper installation, adjustment, alteration, service or maintenance can cause property damage, personal injury or loss of life. Installation and service must be performed by a licensed professional HVAC installer or equivalent, service agency, or the gas supplier

Installation

- 1 - Set thermostat to lowest setting. The gas supply must be shut off prior to disconnecting the electrical power and proceeding with the conversion.
 - 2 - Turn automatic gas valve knob to **OFF** position.
 - 3 - Disconnect gas supply from gas valve. Disconnect wiring at gas valve. Use 5/16" driver to remove four screws which secure the manifold/gas valve assembly. Remove manifold/gas valve assembly.
 - 4 - Remove existing burner orifices. Apply pipe thread compound to threads of orifices provided in kit. Install orifices in manifold. See 1.
- IMPORTANT - Do not allow pipe thread compound to enter orifice bore.*
- IMPORTANT - Install gas valve changeover sticker provided in valve conversion kit to visible area of gas valve.*
- 5 - Install gas valve conversion kit. Refer to manufacturer's instruction packed in valve conversion kit. See figures 2, 3, or 4.
 - 6 - Disconnect ignition and sensor wires from electrodes on burner bracket.
 - 7 - Use 5/16" driver to remove two #10-16 X 5/8" HWHSMS screws which secure the burner bracket.
 - 8 - Remove the burner assembly from the burner box.

⚠ CAUTION

As with any mechanical equipment, contact with sharp sheet metal edges can result in personal injury. Take care while handling this equipment and wear gloves and protective clothing.

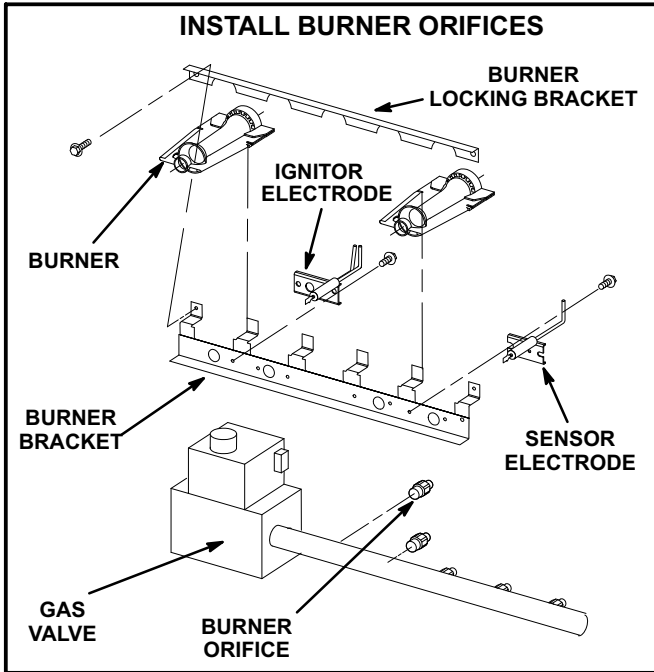
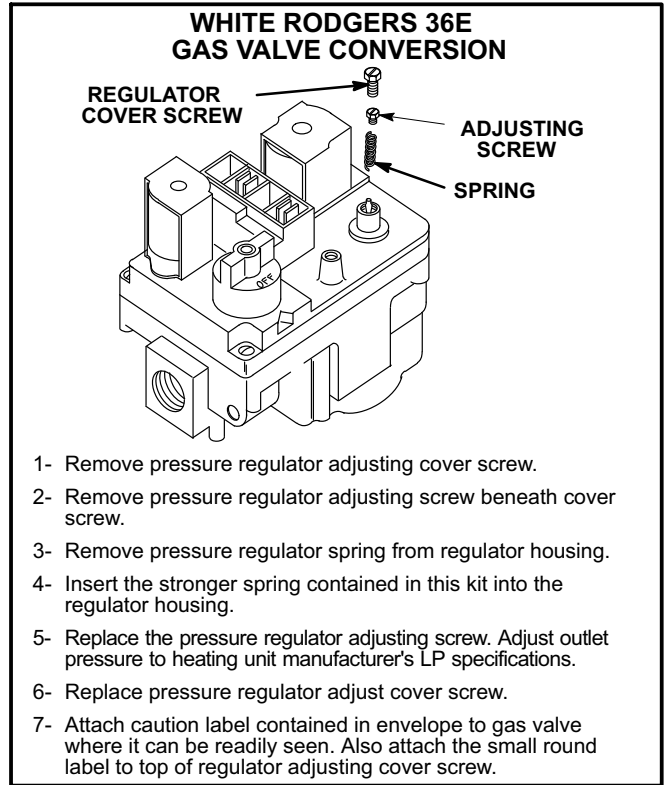

FIGURE 1



- 1- Remove pressure regulator adjusting cover screw.
- 2- Remove pressure regulator adjusting screw beneath cover screw.
- 3- Remove pressure regulator spring from regulator housing.
- 4- Insert the stronger spring contained in this kit into the regulator housing.
- 5- Replace the pressure regulator adjusting screw. Adjust outlet pressure to heating unit manufacturer's LP specifications.
- 6- Replace pressure regulator adjust cover screw.
- 7- Attach caution label contained in envelope to gas valve where it can be readily seen. Also attach the small round label to top of regulator adjusting cover screw.

FIGURE 3

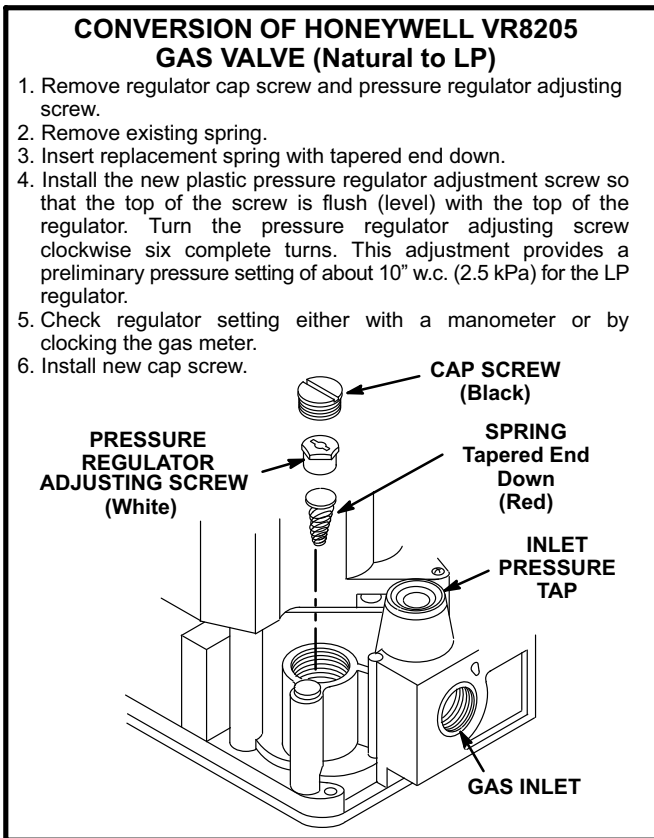
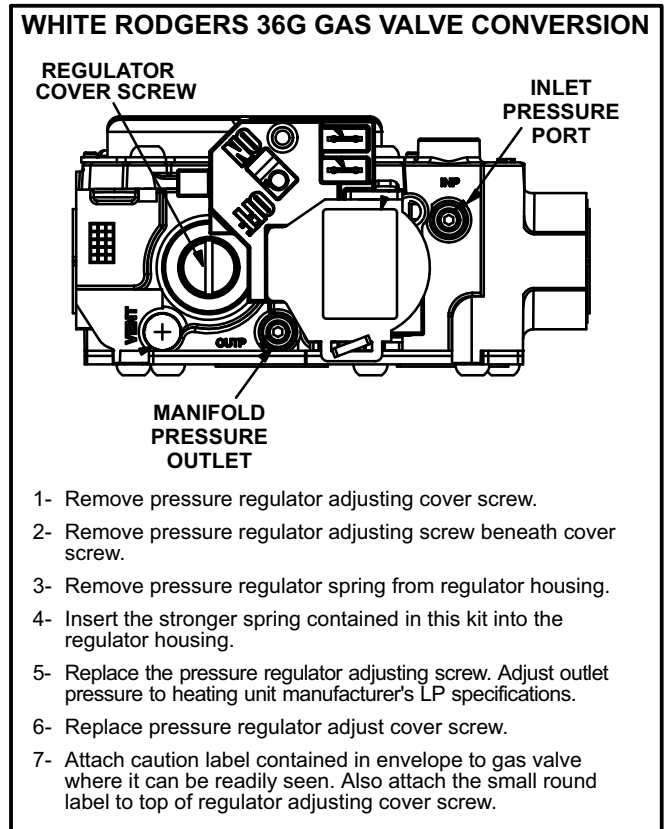

FIGURE 2



- 1- Remove pressure regulator adjusting cover screw.
- 2- Remove pressure regulator adjusting screw beneath cover screw.
- 3- Remove pressure regulator spring from regulator housing.
- 4- Insert the stronger spring contained in this kit into the regulator housing.
- 5- Replace the pressure regulator adjusting screw. Adjust outlet pressure to heating unit manufacturer's LP specifications.
- 6- Replace pressure regulator adjust cover screw.
- 7- Attach caution label contained in envelope to gas valve where it can be readily seen. Also attach the small round label to top of regulator adjusting cover screw.

FIGURE 4

- Pick required number of turbulators for the unit heater: four turbulators for LF24/SEP-100; five for LF24-125; six for LF24-150.

IMPORTANT - When handling turbulators wear gloves and goggles and NIOSH approved dust and mist respirator. Wash exposed skin areas with soap and warm water after handling.

- Carefully insert turbulator assemblies into heat exchanger tubes. Orient as shown in figure 5.

NOTE - Turbulators are brittle - take care in handling.

- Install retainers on vest panel to secure the turbulators. Fasten each retainer with three #8-18 X 1/2 SDST self-drilling screws supplied in the kit.

NOTE - For model LF24-125, shorten the retainer by cutting off one segment.

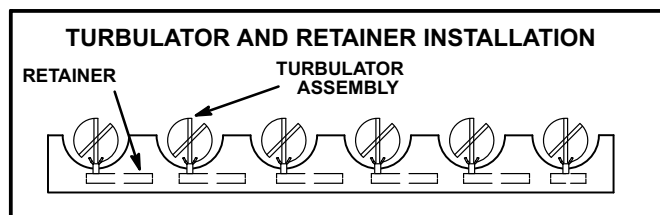

FIGURE 5

- Reinstall burner assembly in burner box using two #10-16 X 5/8" HWHSMS screws and 5/16" driver.
- Reconnect ignition wire and sensor wire.
- Reinstall manifold/valve assembly. Secure with four #10-16 X 5/8" HWHSMS screws.

Install Pressure Switch - VR8205 & 36E

- For Honeywell VR8205 series gas valve connect the 1/8" X 2-1/2" BIP nipple to pressure switch (both supplied in the LP kit). Apply pipe thread compound to the nipple thread before connecting parts.
- For White Rodgers 36E series gas valve use the 1/8" X 90° BIP elbow and two BIP nipples to install pressure switch (all parts supplied in the LP kit). Apply pipe thread compound to the nipple threads before connecting parts.
- Remove cap screw from inlet pressure tap on gas valve. Apply pipe thread compound to threads of the 1/8" BIP nipple and screw the pressure switch/BIP nipple assembly into the inlet pressure tap on the gas valve. See figures 2 or 3 for gas valve inlet pressure tap location. Figures 6 and 7 show installed pressure switches.

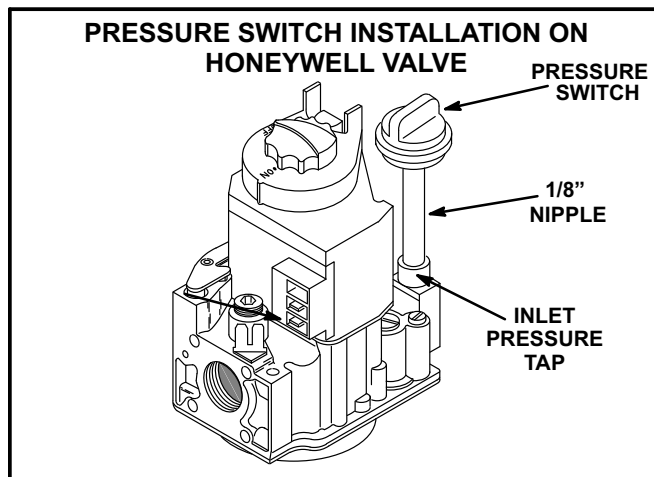

FIGURE 6

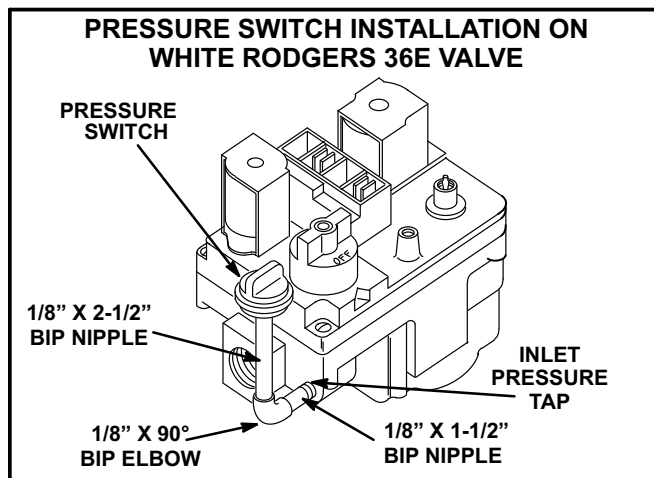

FIGURE 7

Install Pressure Switch - 36G

- For White Rodgers 36G series gas valves, use the 1/8" X 1.5" BIP nipple and the brass adapter to install the pressure switch (all parts supplied in kit). Apply pipe thread compound to the nipple threads before connecting to the switch and brass adapter.
- Thread the brass adapter into the gas inlet and tighten by hand. Using the properly sized wrench, tighten the fitting taking care to position the side port as shown in figure 8. Apply pipe thread compound to the adapter threads before connecting to gas valve.

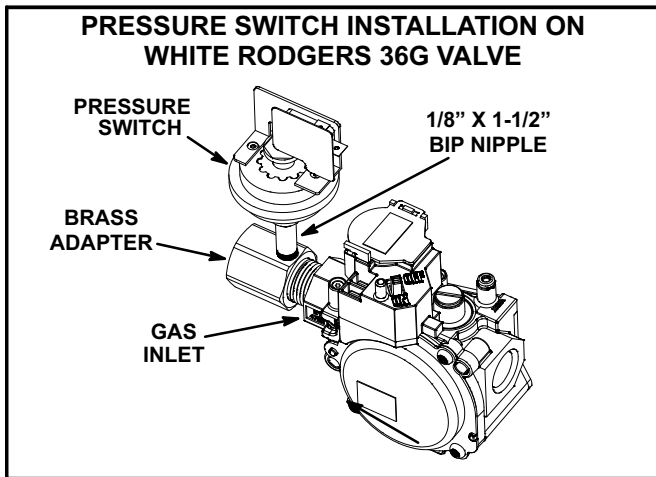

FIGURE 8

Connect Switch Wiring and Gas Supply

- 1- Connect the insulated end of blue wire (provided) to pressure switch terminal "C" (common). Connect the other end of the blue wire to the gas valve terminal. Connect the blue wire from the control board to "NO" terminal on the pressure switch. Reconnect the yellow wire from the control board to the other terminal on gas valve. See figure 9.
- 2- Connect gas supply to gas valve or brass adapter.
- 3- Restore gas to unit.

IMPORTANT - Carefully check all piping connections. DO NOT use matches, candles, open flame or other means of ignition to check for gas leaks. Use a soap solution or other preferred means.

- 4- Affix unit conversion stickers provided in the kit adjacent to unit rating plate.

! IMPORTANT

Some soaps used for leak detection are corrosive to certain metals. Carefully rinse piping thoroughly after leak test has been completed. Do not use matches, candles, flame or other sources of ignition to check for gas leaks.

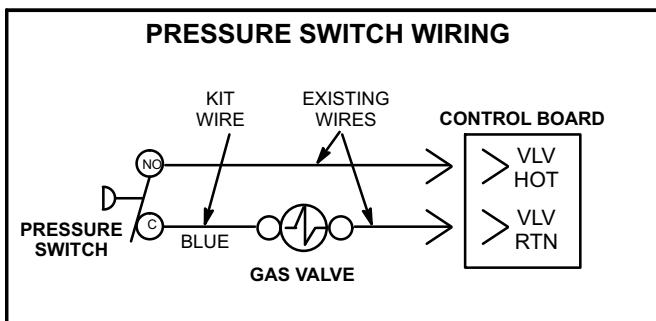

FIGURE 9

Start-Up And Adjustments

BEFORE LIGHTING, smell all around the appliance area for gas. Be sure to smell next to the floor because some gas is heavier than air and will settle on the floor.

Use only your hand to push in or turn the gas control knob. Never use tools. If the knob will not push in or turn by hand, do not try to repair it, call a qualified service technician. Force or attempted repair may result in a fire or explosion.

A - Placing Unit In Operation:

IMPORTANT - Follow the lighting instructions provided on the unit. If lighting instructions are not available, see section below.

LF24 and SEP unit heaters are equipped with an automatic spark ignition system. DO NOT attempt to manually light burners on these furnaces. Each time thermostat calls for heat, the burners will automatically be lit.

- 1 - Make sure thermostat is set below room temperature and power is turned off to unit.
- 2 - This appliance is equipped with an ignition device which automatically lights the burners. DO NOT try to light the burners by hand.
- 3 - Turn knob on gas valve clockwise to OFF. Do not force.
- 4 - Wait 15 minutes to clear out any gas. If you then smell gas, immediately call your gas supplier from an outside phone. Follow the gas supplier's instructions. If you do not smell gas go to next step.
- 5 - Turn knob on gas valve counterclockwise to ON.
- 6 - Turn on all electrical power to unit.
- 7 - Set thermostat to desired setting.

NOTE - When unit is initially started, steps 1 through 7 may need to be repeated to purge air from gas line.

B - Gas Pressure Adjustment

- 1 - Check gas line supply pressure with unit firing at maximum rate. A minimum of 11.0" w.c. should be maintained.
- 2 - After gas line pressure has been checked and adjusted, check manifold pressure at the pressure tap on the outlet side of the gas valve. The correct manifold pressure for LP/propane gas is shown in table 1. Refer to figures 2 , 3, or 4 for gas manifold pressure adjustment screw location.

C - Burner

Burner flame - Start burner and allow to operate for a few minutes. Observe flame. Flame should be predominantly blue (with some yellow), strong and steady. Flame should burn continuously from all burners.

TABLE 1

GAS MANIFOLD PRESSURES (PROPANE)		
Unit Model	0-2000 Ft. (0-610m)	2001-4500 Ft. (610-1376m)
LF24/SEP-100	9.0" w.c.	9.0" w.c.
LF24-125	9.0" w.c.	9.0" w.c.
LF24-150	9.0" w.c.	9.0" w.c.

NOTE - In the USA, refer to the unit installation instructions for elevations above 4500 ft. (1376m).

D - Means To Verify Gas Rate

Input must not exceed amount shown on unit rating plate. In cases where gas is not metered, the service technician performing the conversion will need to supply the meter. Input may then be checked by the following method: The utility company or LP/propane gas distributor may be contacted for the heating value of the gas. All other appliances should be shut off during the input check.

Locate meter just upstream in regulated pressure (10.0" w.c. to 13.0"w.c.). To check the Btu input rate, the dial hand on the gas meter should be timed for at least one revolution, using the one cubic foot dial. To assure accurate measurements, use temperature and pressure correction factors for the meter.

To determine the number of seconds required for the flow of one cubic foot of gas, use the following formula:

(BTUH CONTENT)
HEATING VALUE OF GAS X 3600

UNIT BTUH INPUT

Example: 2500 BTU gas
Unit input 115,000 BTUH

Seconds for one cubic foot =

$$\frac{2500 \times 3600}{115,000} = 78 \text{ seconds}$$

E - Ignition System

Check the normal operation sequence of the ignition system after conversion. See instruction manual supplied with the unit.

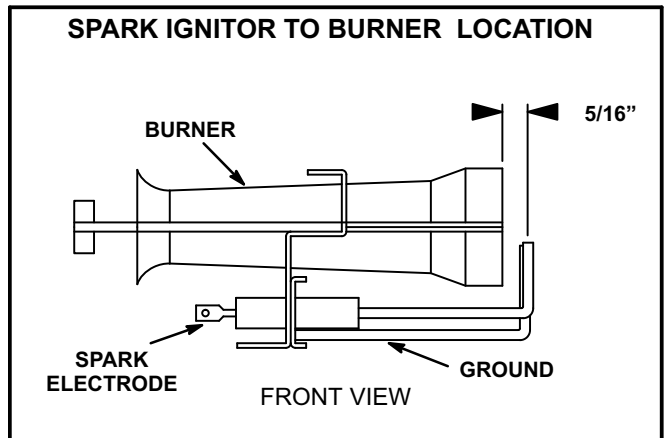

FIGURE 10