

INSTALLATION INSTRUCTIONS

4HP14/15 SPLIT SYSTEM HEAT PUMP

(R410A REFRIGERANT)

This manual must be left with the homeowner for future reference.



This is a safety alert symbol and should never be ignored. When you see this symbol on labels or in manuals, be alert to the potential for personal injury or death.

Table of Contents

Safety Precautions	2
Installation	2
Electrical Connections	5
Start-Up Procedure.....	6
Operation.....	7
Homeowner's Information	10

NOTE

These instructions are intended as a general guide and do not supersede national, state or local codes in any way.

NOTE TO INSTALLING DEALER

These instructions and warranty are to be given to the owner or displayed near the indoor air handler unit.

WARNING

Installation or repairs made by unqualified persons can result in hazards to you and others. Installation MUST conform with local building codes and with the National Electrical Code NFPA 70/ANSI C1-1993 or current edition and Canadian Electrical Code Part 1 CSA C22.1.

CAUTION

Improper installation, adjustment, alteration, service or maintenance will void the warranty. The qualified installer or agency must use factory-authorized kits or accessories when added to this products. Refer to the individual instructions included with the specific accessory kit.

WARNING

Before installing, modifying, or servicing system, main electrical disconnect switch must be in the OFF position. There may be more than 1 disconnect switch. Lock out and tag switch with a suitable warning label. Electrical shock can cause personal injury or death.

215 Metropolitan Drive
West Columbia, SC 29170



(P) 506318-03

Save these instructions for future reference

These units are designed for use in residential and light commercial type buildings. Heat Pumps may only be installed with indoor combinations listed in the Air Conditioning, Heating and Refrigeration Institute (AHRI) Directory of Certified Products.

Inspect the unit for any damage before installation. If damage is found, notify the transportation company immediately and file a concealed damage claim.

Safety Precautions

Follow all safety codes. Wear safety glasses and work gloves. Use quenching cloth for brazing operations. Have fire extinguisher available. Read these instructions thoroughly and follow all warning or cautions attached to the unit.

1. Always wear proper personal protection equipment.
2. Always disconnect electrical power before removing panel or servicing equipment.
3. Keep hands and clothing away from moving parts.
4. Handle refrigerant with caution, refer to proper MSDS from refrigerant supplier.
5. Use care when lifting, avoid contact with sharp edges.

Installation

NOTE: *In some cases noise in the living area has been traced to gas pulsations from improper installation of equipment.*

1. Locate unit away from windows, patios, decks, etc. where unit operation sounds may disturb customer.
2. Ensure that vapor and liquid tube diameters are appropriate to capacity of unit.
3. Run refrigerant tubes as directly as possible by avoiding unnecessary turns and bends.
4. Leave some slack between structure and unit to absorb vibration.
5. When passing refrigerant tubes through the wall, seal opening with RTV or other silicon-based caulk.
6. Avoid direct tubing contact with water pipes, duct work, floor joists, wall studs, floors, walls, and any structure.
7. Do not suspend refrigerant tubing from joists and studs with a rigid wire or strap which comes in direct contact with tubing.
8. Ensure that tubing insulation is pliable and completely surrounds vapor tube.

When outdoor unit is connected to factory-approved indoor unit, outdoor unit contains system refrigerant charge for operation with indoor unit of the same size when connected by 15 ft. of field-supplied tubing. For proper unit operation, check refrigerant charge using charging information located on control box cover.

NOTE: *Maximum liquid-line size is 3/8 in. O.D. for all residential applications including long lines.*

Outdoor Section

Zoning ordinances may govern the minimum distance the condensing unit can be installed from the property line.

Install on a Solid, Level Mounting Pad

The outdoor section is to be installed on a solid foundation. This foundation should extend a minimum of 2" (inches) beyond the sides of the outdoor section. To reduce the possibility of noise transmission, the foundation slab should NOT be in contact with or be an integral part of the building foundation.

Elevate Unit



Accumulation of water and ice in base pan may cause equipment damage.

Elevate unit per local climate and code requirements to provide clearance above estimated snowfall level and ensure adequate drainage of unit. Use snow stand in areas where prolonged freezing temperatures are encountered.

If conditions or local codes require the unit be attached to pad or mounting frame, tie down bolts should be used and fastened through knockouts provided in unit base pan.

Rooftop Installations

Mount on level platform or frame 6 inches above roof surface. Place unit above a load-bearing wall and isolate unit and tubing set from structure. Arrange supporting members to adequately support unit and minimize transmission of vibration to building. Ensure roof structure and anchoring method is adequate for location. Consult local codes governing rooftop applications.

Roof mounted units exposed to winds above 5 mph may require wind baffles to achieve adequate defrost. A sheet metal baffle should be spaced 6-1/2" from the fall of the coil. The height should cover the face of the coil and the length should be 6" from the access panel.

NOTE: *Unit must be level to within $\pm 1/4$ in./ft. per compressor manufacturer specifications.*

Clearance Requirements

When installing, allow sufficient space for airflow clearance, wiring, refrigerant piping, and service. For proper airflow, quiet operation and maximum efficiency. Position so water, snow, or ice from roof or eaves cannot fall directly on unit.

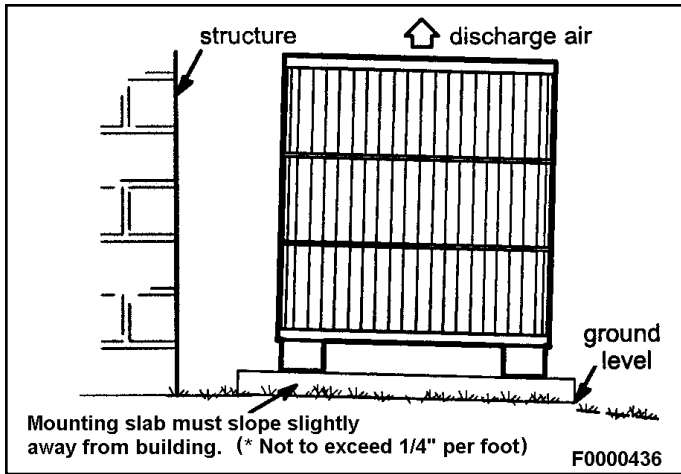

Figure 1.

DO LOCATE THE UNIT:

- With proper clearances on sides and top of unit
- On a solid, level foundation or pad
- To minimize refrigerant line lengths

DO NOT LOCATE THE UNIT:

- On brick, concrete blocks or unstable surfaces
- Near clothes dryer exhaust vents
- Near sleeping area or near windows
- Under eaves where water, snow or ice can fall directly on the unit
- With clearance less than 2 ft. from a second unit
- With clearance less than 4 ft. on top of unit

Operating Ambient

The minimum outdoor operating ambient in cooling mode is 55°F, and the maximum outdoor operating ambient in cooling mode is 125°F. The maximum outdoor operating ambient in heating mode is 66°F.

Refrigeration Line Sets

Use only refrigerant grade copper tubes. Split systems may be installed with up to 50 feet of line set (no more than 20 feet vertical) without special consideration (see long line set guidelines).

It is important that no tubing be cut or seals broken until you are ready to actually make connections to the evaporator and to the condenser section. DO NOT remove rubber plugs or copper caps from the tube ends until ready to make connections at evaporator and condenser. Under no circumstances leave the lines open to the atmosphere for any period of time, if so unit requires additional evacuation to remove moisture.

Capacity	Liquid		Vapor	
	Connections Dia.	Tube Dia.	Connections Dia.	Tube Dia.
-018	3/8"	3/8"	3/4"	3/4"
-024	3/8"	3/8"	3/4"	3/4"
-030	3/8"	3/8"	3/4"	3/4"
-036	3/8"	3/8"	7/8"	7/8"
-042	3/8"	3/8"	7/8"	7/8"
-048	3/8"	3/8"	7/8"	7/8"
-060	3/8"	3/8"	7/8"	*1-1/8"

* Field supplied 7/8 x 1-1/8 connector required on both ends of vapor tubing.

Table 1. Recommended Liquid & Vapor Tube Diameters (in.)

Be extra careful with sharp bends. Tubing can “kink” very easily, and if this occurs, the entire tube length will have to be replaced. Extra care at this time will eliminate future service problems.

It is recommended that vertical suction risers not be up-sized. Proper oil return to the compressor should be maintained with suction gas velocity.

Filter Drier

The filter drier is very important for proper system operation and reliability. If the drier is shipped loose, it must be installed by the installer in the field. Unit warranty will be void, if the drier is not installed.

Installation of Line Sets

DO NOT fasten liquid or suction lines in direct contact with the floor or ceiling joist. Use an insulated or suspension type of hanger. Keep both lines separate, and always insulate the suction line. Long liquid line runs (30 feet or more) in an attic will require insulation. Route refrigeration line sets to minimize length.

DO NOT let refrigerant lines come in direct contact with foundation. When running refrigerant lines through the foundation or wall, openings should allow for a sound and vibration absorbing material to be placed or installed between tubing and foundation. Any gap between foundation or wall and refrigerant lines should be filled with a vibration damping material.

CAUTION
 If ANY refrigerant tubing is required to be buried by state or local codes, provide a 6 inch vertical rise at service valve.

Before making braze connections, be sure all joints are clean. Before heat is applied for brazing, dry nitrogen should be flowing through the tubing to prevent oxidation and scale formation on the inside of the tubing.

The following is the recommended method for making braze connections at the refrigerant line connections:

1. Debur and clean refrigerant tube end with emery cloth or steel brush.
2. Insert tubing into swage fitting connection.
3. Wrap wet rags over valves to protect from heat.
4. Allow dry nitrogen to flow through refrigerant lines.
5. Braze joint, using a suitable brazing alloy for copper to copper joints.
6. Quench the joint and tubing with water using a wet rag. Leave rag on fitting body and re-wet with water to help cool area.

Leak Check

Refrigeration lines and indoor coil must be checked for leaks after brazing and before evacuation. The recommended procedure is to apply a trace amount of vapor refrigerant (approximately two ounces or 3 psig) into the line set and indoor coil, then pressurize with 150 psig of dry nitrogen. Use a refrigerant leak detector to check all joints. The system may also be checked for leaks using a halide torch or pressure and soapy solution. After completion of leak check, relieve all pressure from system before evacuation.

Evacuating and Charging Instructions

NOTE: *Intentional release of CFC or HCFC refrigerant to the atmosphere violates Federal Law. It may also violate State and Local Codes. Check all Federal, State and Local Codes before proceeding.*

These outdoor units are pre-charged at the factory with adequate refrigerant to handle 15 feet of refrigerant tubing.

NOTE: *DO NOT use any portion of the charge for purging or leak testing. It is mandatory that a thorough evacuation of the refrigeration lines and indoor coil be performed.*

The liquid line and suction line service valves have been closed after final testing at the factory. **DO NOT disturb these valves until the lines have been leak checked and evacuated or the charge in the unit may be lost.**

1. Connect the vacuum pump to the center hose of the manifold gauge set, the low-pressure manifold gauge to the vapor service valve and the high pressure manifold gauge to the liquid service valve.

NOTE: *Unnecessary switching of hoses can be avoided and complete evacuation of all lines can be achieved by also connecting a branch hose from the manifold gauge center port to a cylinder of the proper refrigerant. Provide a separate shut-off valve to vacuum pump to avoid contaminating vacuum pump oil with refrigerant.*

2. The valves should be kept in the "front seated" (closed) position. This will allow evacuation of the refrigeration lines and the indoor coil, without disturbing the factory charge in the outdoor unit.
3. Follow the vacuum pump manufacturer's instructions. Allow the pump to operate until the system has been evacuated down to 300 microns. Allow the pump to continue running for an additional 15 minutes. Turn OFF the pump and leave the connections secured to the two (2) service valves. After 5 minutes, if the system fails to hold 500 microns or less, check all connections for tight fit and repeat the evacuation procedure.
4. Isolate the vacuum pump from the system by closing the shutoff valves on the gauge-set. Disconnect the vacuum pump.

Opening Service Valves

After evacuation of the connecting lines, remove the service valve cap and fully insert the hex wrench into the stem. A back-up wrench is required on the valve body to open the valve stem. Back-out counterclockwise until the valve stem just touches the coined edge.

Wrench sizes:

- 3/8 service valve: 3/16" Hex wrench
- 3/4 service valve: 5/16" Hex wrench
- 7/8 service valve: 5/16" Hex wrench

Replace service valve cap and torque to 8-11 ft-lb on 3/8" valves; 12-15 ft-lb on 3/4" valves; 15-20 ft-lb on 7/8" valves. Use backup wrench on valve body when torquing valve cap.

Install Electrical Accessories

Refer to the instructions packaged with the accessories.

Electrical Connections

⚠ WARNING

Electrical Shock Hazard!



Turn OFF electric power before connecting unit, performing any maintenance or removing panels or doors. More than one disconnect may be required to turn off all power.

FAILURE TO DO SO COULD RESULT IN BODILY INJURY OR DEATH.

Be sure to check all local codes to determine that the unit is installed accordance with local requirements. Consult the National Electric Code for wire size requirements. Use 60 C wire or higher. Always provide ground connections to the outdoor unit. Power supply must agree with rating on unit nameplate.

Provide line voltage power supply to unit from a properly sized disconnect switch. Route power and ground wires from disconnect switch to unit. Line voltage connections are made at the line side of the contactor in the control box of the outdoor unit. Follow the appropriate wiring diagram attached to inside of the access panel.

Proper circuit protection recommendations are indicated on Unit Rating Plate. Time delay fuses are required to prevent blowing due to starting current (the current in rush when equipment starts is referred to as the Locked Rotor Amps or (LRA). A fuse of this kind properly sized will give maximum equipment protection.

Use copper wire only between disconnect switch and unit.

Remove access panel to gain access to unit wiring. Extend wires from disconnect through power wiring hole provided and into unit control box. Flexible conduit is required for the swing out control box feature.

⚠ WARNING

The unit cabinet must have an uninterrupted or unbroken ground to minimize personal injury if an electrical fault should occur. The ground may consist of electrical wire or metal conduit when installed in accordance with existing electrical codes. Failure to follow this warning can result in an electric shock, fire, or death.

Connect ground wire to ground connection in control box for safety. Connect power wiring to contactor.

High voltage power connections to 3-phase models is made to "Pig Tail" leads with field supplied splice connectors.

Control Wiring

The control voltage is 24 VAC. NEC Class I insulated 18 AWG is required for control wiring. For lengths longer than 150 feet, contact your local distributor for technical service.

Ensure the room thermostat is properly installed per instructions shipped with room thermostat. Generally the thermostat should not be exposed to sunlight, drafts or vibration and should not be mounted on exterior walls.

Low voltage control wire connections should be made to the screw connection terminal board mounted on the defrost control as shown. All low voltage control wiring must be separated from incoming power leads.

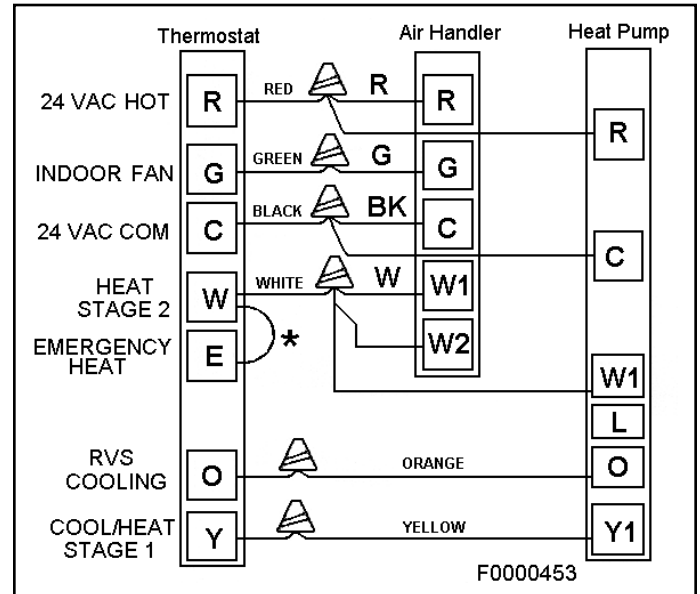

Figure 2.

Heat Pump Application with Electric Heat Emergency Heat (Heating Heat Pump)

If selector switch on thermostat is set to the emergency heat position, the heat pump will be locked out of the heating circuit, and all heating will be electric heat (if applicable). A jumper should be placed between W and E on the thermostat so that the electric heat control will transfer to the first stage heat on the thermostat. This will allow the indoor blower to cycle on and off with the electric heat when the fan switch is in the AUTO position.

* Add Jumper on Subbase (Optional)

Start-Up Procedure

1. Check to ensure:
 - Service valve and gage port caps are installed and tightened.
 - Voltage supply at unit agrees with nameplate rating.
 - Field wiring connections are tight and factory wiring has not been disturbed and are tight.
 - Indoor fan motor is on correct speed tap.
2. Set thermostat selector switch to OFF and fan control switch to "Auto" is so equipped.
3. Close electrical disconnects to energize system.
4. Set room thermostat at desired temperature. Be sure set point is below indoor ambient temperature.
5. Set the system switch of the thermostat on COOL (or HEAT if applicable) and fan switch for continuous operation (ON) or AUTO, as desired. There will be a 5 minute short cycle compressor delay on startup. Operate unit for 15-20 minutes, then check the system refrigerant charge.
6. Adjust refrigerant charge per "Adjusting Charge" section.

Adjusting Charge

Factory charge is shown on the rating label located on the access panel.

All split system heat pumps are factory charged for 15 feet of connecting line set and matched indoor fan coil.

Nameplate refrigerant charge should initially be adjusted for line set lengths other than 15 feet. For line sets shorter than 15 feet in length, remove charge. For line sets longer than 15 feet, add charge. Oil charge is sufficient for all line lengths.

Refrigeration Charge Adjustment	
Liquid Line Diameter	Oz. Per Linear Foot
3/8"	0.6
* Factory charge for series is for 15' (ft.) line sets and matched fan coil.	

Table 2.

Before final adjustment is made to the refrigerant charge, it is imperative that proper indoor airflow be established. Airflow will be higher across a dry coil versus a wet coil. Blower charts are calculated with a dry or wet coil basis. Recommended airflow is 350-450 CFM per ton (12,000 Btuh) through a wet coil. Refer to indoor unit instructions for methods of determining air flow and blower performance.

The optimum method for checking the charge is by weight. However the following methods may be used to confirm the proper charge:

Cooling Mode

1. Operate unit a minimum of 10 minutes before checking charge.
2. Measure liquid service valve pressure by attaching an accurate gage to service port. Determine saturation temp. from T/P chart.
3. Measure liquid line temperature by attaching an accurate thermistor type or electronic thermometer to liquid line near outdoor coil.
4. Calculate subcooling (saturation temp. measured temp.) and compare with table on back of central box cover.
5. Add refrigerant if subcooling is lower than table. Recover refrigerant if subcooling is high.
6. If ambient temp is lower than 60°F, check charge in heating mode or weigh refrigerant according to name plate data.

Heating Mode

Check charge in heating mode if ambient temp is below 60° F. Indoor temp must be between 65° and 75° F.

Follow steps (1) to (6) above and compare with heating mode subcooling range on the table on back of central box cover.

Charge must be rechecked again during the cooling season.

Cold Weather Application

A cold weather accessory kit may be required for heat pumps operating at ambient conditions below 25°F. Supplemental heat should be provided for these conditions due to the expected performance degeneration.

Operation

The outdoor unit and indoor blower cycle on demand from the room thermostat. When the thermostat blower switch is in the ON position, the indoor blower operates continuously.

Emergency Heat Function (Room Thermostat)

An emergency heat function is designed into some room thermostats. This feature is applicable when isolation of outdoor unit is required or when auxiliary electric heat is staged by outdoor thermostats. When the room thermostat is placed in the emergency heat position, the outdoor unit control circuit is isolated from power and field-provided relays bypass the outdoor thermostats. An amber indicating light simultaneously comes on to remind the homeowner that he is operating in the emergency heat mode.

Emergency heat is usually used during an outdoor unit shutdown, but it should also be used following a power outage. If power has been off for over an hour and the outdoor temperature is below 50°F (10°C). System should be left in the emergency heat mode at least six hours to allow the crankcase heater sufficient time to prevent compressor slugging. This applies only to systems with crank case heaters.

Defrost System

The defrost system includes two (2) components: a defrost thermostat and a defrost control.

Defrost Thermostat

The defrost thermostat is located on the outdoor coil of most models and on the liquid line between the check/expansion valve and the distributor on R-410A TXV equipped models. When defrost thermostat senses 29°F (42 on R-410A TXV's) or cooler, the thermostat contacts close and send a signal to the defrost control board to start the defrost timing. It also terminates defrost when the liquid line warms up to 60°F.

Defrost Control

The defrost control board includes the combined functions of a time/temperature defrost control, defrost relay, diagnostic LEDs and terminal strip for field wiring connections.

The control provides automatic switching from normal heating operation to defrost mode and back. During compressor cycle, the control accumulates compressor run times at 30-, 60-, or 90-minute field-adjustable intervals. If the defrost thermostat is closed when the selected compressor run time interval ends (call for defrost), the defrost relay is energized and defrost begins. The factory setting is 90 minutes which is the optimum efficiency setting.

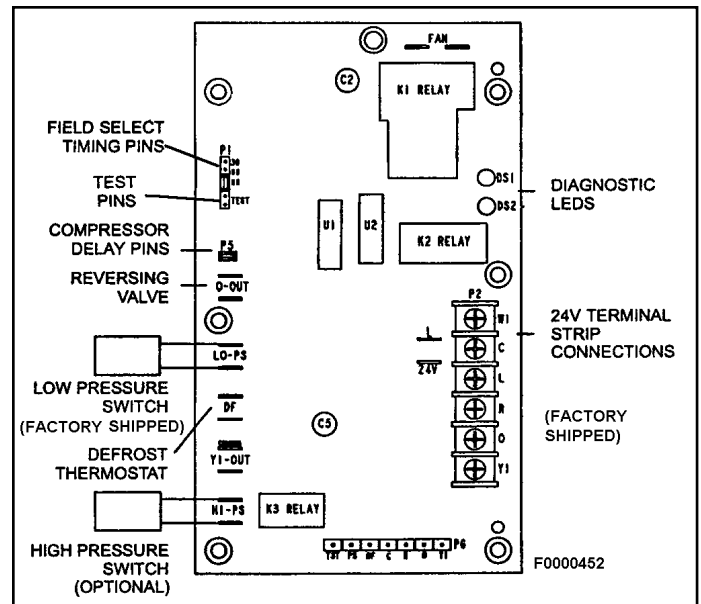

Figure 3. Outdoor Unit Defrost Control Board

Defrost Control Timing Pins

Each timing pin selection provides a different accumulated compressor run time period for one defrost cycle. This time period must occur before a defrost cycle is initiated. The defrost interval can be adjusted to 30 (T1), 60 (T2), or 90 (T3) minutes. If the timing selector jumper is not in place the control defaults to a 90-minute defrost interval. The maximum defrost period is 14 minutes and cannot be adjusted.

A TEST option is provided for troubleshooting. The TEST mode may be started any time the unit is in the heating mode and the defrost thermostat is closed or jumpered. If the jumper is in the TEST position at power-up, the control will ignore the test pins. When the jumper is placed across the TEST pins for 2 seconds, the control will enter the defrost mode. If the jumper is removed before an additional 5 second period has elapsed (7 seconds total), the unit will remain in defrost mode until the defrost thermostat opens or 14 minutes have passed. If the jumper is not removed until after the additional 5 second period has elapsed, the defrost will terminate and the test option will not function again until the jumper is removed and re-applied.

Time Delay

The timed-off delay is 5 minutes long. The delay help to protect the compressor from short-cycling in case the power to the unit is interrupted or a pressure switch opens. The delay is bypassed by placing the timer select jumper across the TEST pins for 0.5 seconds.

Pressure Switch Circuit

The defrost control incorporates 2 pressure switch circuits. The high pressure switch connects to the boards HI PS terminals. The low pressure switch is factory installed.

During a single demand cycle, the defrost control will lock out the unit after the fifth time that the circuit is interrupted by any pressure switch wired to the control board. In addition, the diagnostic LEDs will indicate a locked-out pressure switch after the fifth occurrence of an open pressure switch. The unit will remain locked out until power to the board is interrupted, then re-established or until the jumper is applied to the TEST pins for 0.5 seconds.

NOTE: The defrost control board ignores input from the low-pressure switch terminals as follows:

- During the TEST mode,
- During the defrost cycle,
- During the 90 second start-up period,
- And for the first 90 seconds each time the reversing valve switches heat/cool modes. If the TEST pins are jumpered and the 5 minute delay is being by-passed, the LO PS terminal signal is not ignored during the 90 second start-up period.

Diagnostic LEDs

The state (Off, On, Flashing) of two LEDs on the defrost board (DS1 [Red] and DS2 [Green]) indicate diagnostics conditions that are described in Table 3.

Mode	Green LED (DS2)	Red LED (DS1)
No power to control	Off	Off
Normal operation / power to control	Simultaneous slow flash	
Anti-short cycle lockout	Alternating slow flash	
Low pressure switch fault	Off	Slow flash
Low pressure switch lockout	Off	On
High pressure switch fault	Slow flash	Off
High pressure switch lockout	On	Off

Table 3.

Defrost Board Pressure Switch Connections

The unit's automatic reset pressure switches (LO PS - S87 and HI PS - S4) are factory-wired into the defrost board on the LO-PS and HI-PS terminals, respectively.

Low Pressure Switch (LO-PS) — When the low pressure switch trips, the defrost board will cycle off the compressor, and the strike counter in the board will count one strike. The low pressure switch is ignored under the following conditions:

- during the defrost cycle and 90 seconds after the termination of defrost
- when the average ambient sensor temperature is below 15° F (-9°C)
- for 90 seconds following the start up of the compressor
- during “test” mode

High Pressure Switch (HI-PS) — When the high pressure switch trips, the defrost board will cycle off the compressor, and the strike counter in the board will count one strike.

Defrost Board Pressure Switch Settings

- High Pressure (auto reset) - trip at 590 psig; reset at 418.
- Low Pressure (auto reset) - trip at 25 psig; reset at 40.

5-Strike Lockout Feature

The internal control logic of the board counts the pressure switch trips only while the Y1 (Input) line is active. If a pressure switch opens and closes four times during a Y1 (Input), the control logic will reset the pressure switch trip counter to zero at the end of the Y1 (Input). If the pressure switch opens for a fifth time during the current Y1 (Input), the control will enter a lockout condition.

The 5-strike pressure switch lockout condition can be reset by cycling OFF the 24-volt power to the control board or by shorting the TEST pins between 1 and 2 seconds. All timer functions (run times) will also be reset.

If a pressure switch opens while the Y1 Out line is engaged, a 5-minute short cycle will occur after the switch closes.

Compressor Delay

The defrost board has a field-selectable function to reduce occasional sounds that may occur while the unit is cycling in and out of the defrost mode. When a jumper is installed on the DELAY pins, the compressor will be cycled off for 30 seconds going in and out of the defrost mode. Units are shipped with jumper installed on DELAY pins.

NOTE: The 30 second compressor delay feature (known as the quiet shift) **must** be deactivated during any unit performance testing. The feature is deactivated by removing the jumper located on the compressor delay pins on the control board mounted inside the unit control box. This feature is optional for the homeowner, but may impact testing performance.

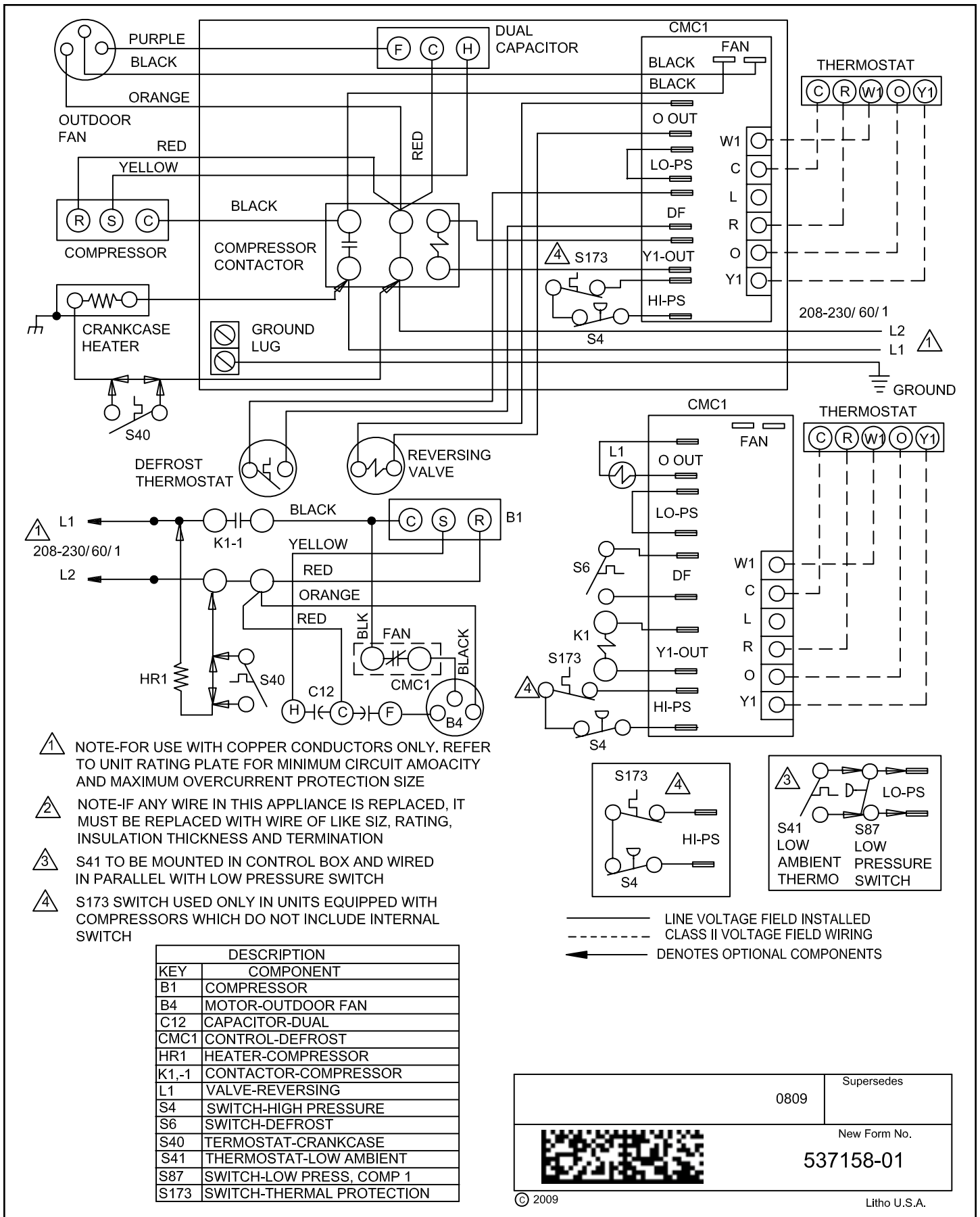

Figure 4. H/P 14/15 SEER Wiring Diagram

Homeowner's Information



WARNING

ELECTRICAL SHOCK HAZARD!

Turn OFF electric power to unit before performing any maintenance or removing panels or doors.

FAILURE TO DO SO COULD RESULT IN BODILY INJURY OR DEATH.

Heat Pump Operation

Your new heat pump has several characteristics that you should be aware of:

- Heat pumps satisfy heating demand by delivering large amounts of warm air into the living space. This is quite different from gas-or oil-fired furnaces or an electric furnace which deliver lower volumes of considerably hotter air to heat the space.
- Do Not be alarmed if you notice frost on the outdoor coil in the winter months. Frost develops on the outdoor coil during the heating cycle when temperatures are below 45°F. An electronic control activates a defrost cycle lasting 5 to 15 minutes at preset intervals to clear the outdoor coil of the frost.
- During the defrost cycle, you may notice steam rising from the outdoor unit. This is a normal occurrence. The thermostat may engage auxiliary heat during the defrost cycle to satisfy a heating demand; however, the unit will run to normal operation at the conclusion of the defrost cycle.

In case of extended power outage...

If the outdoor temperature is below 50°F and power to your outdoor unit has been interrupted for 6 hours or longer, observe the following when restoring power to your heat pump system.

- Set the room thermostat selector to the "Emergency Heat" setting to obtain temporary heat for a minimum of 6 hours. This will allow system refrigerant pressures and temperatures enough time to return to a stabilized condition.
- In Emergency Heat mode, all heating demand is satisfied by auxiliary heat; heat pump operation is locked out. After a 6 hour "warm-up" period, the thermostat can then be switched to the "Heat" setting and normal heat pump operation may resume.
- Heat pumps (in the cooling mode) remove humidity from your home. Depending on the amount of moisture in the air inside your home, water will trickle from the condensate drain of the cooling coil.

Thermostat Operation

The wall-mounted thermostat controls your air conditioner. The thermostat is available in various configurations from

different manufacturers. The information below is typical for most thermostats. Ask your dealer for specific information regarding the model of thermostat installed.

Temperature Setting Levers

Most heat pump thermostats have 2 temperature selector levers: one for heating and one for cooling. Set the levers or dials to the desired temperature set points for both heating and cooling. Avoid frequent temperature adjustment; turning the unit off and back on before pressures equalize puts stress on the unit compressor.

On heat pump systems, increasing your thermostat setting by more than 2 degrees may cause supplemental heaters to turn on, reducing potential energy savings.

Fan Switch

In AUTO or INT (intermittent) mode, the blower operates only when the thermostat calls for heating or cooling. This mode is generally preferred when humidity control is a priority. The ON or CONT mode provides continuous indoor blower operation, regardless of whether the compressor or auxiliary heat are operating. This mode is required when constant air circulation or filtering is desired.

System Switch

Set the system switch for heating, cooling or auto operation. The auto mode allows the heat pump to automatically switch from heating mode to cooling mode to maintain predetermined comfort settings. Many heat pump thermostats are also equipped with an emergency heat mode which locks out heat pump operation and provides temporary heat supplied by the auxiliary heat.

Indicating Light

Most heat pump thermostats have an amber light which indicates when the heat pump is operating in the emergency heat mode.

Temperature Indicator

The temperature indicator displays the actual room temperature.

Fan Control

For fan control your thermostat may have a Fan Selection Switch that allows you to run the fan continuously or cycle it automatically with the heating or cooling system. Switch the lever to ON for continuous operation and to AUTO for automatic cycling.

For maximum comfort satisfaction and continual air cleaning/filtering, constant fan operation is recommended.

On models without a fan Selection Switch, the fan will cycle with the outdoor unit.

Important System Information

- Your system should never be operated without a clean air filter properly installed.
- Return air and supply air registers should be free from restrictions or obstructions to allow full flow of air.

Regular Maintenance Requirements

Your system should be regularly inspected by a qualified service technician. These regular visits may include (among other things) checks for:

- Motor operation
- Ductwork air leaks
- Coil & drain pan cleanliness (indoor & outdoor)
- Electrical component operation & wiring check
- Proper refrigerant level & refrigerant leaks
- Proper airflow
- Drainage of condensate
- Air filter(s) performance
- Blower wheel alignment, balance & cleaning
- Primary & secondary drain line cleanliness
- Proper defrost operation (heat pumps)

There is some routine maintenance procedures you can do to help keep your system operating at peak performance between visits.

Air Filter

Inspect air filters at least monthly and replace or clean as required. Disposable filters should be replaced. Washable filters may be cleaned by soaking in mild detergent and rinsing with cold water. Replace filters with the arrows pointing in the direction of airflow. Dirty filters are the most common cause of poor heating / cooling performance and compressor failures.

Indoor Coil

If the system has been operated with a clean filter in place, it should require minimal cleaning. Use a vacuum cleaner and soft brush attachment to remove any accumulation of dust from the top and underside of the finned coil surface. However, perform this maintenance only when the coil is completely dry.

If the coil cannot be cleaned by this method, call your dealer for service. It may need a detergent solution and rinsing with water for cleaning, which may require coil removal. You should not attempt this yourself.

Condensate Drain

During cooling season check at least monthly for free flow of drainage and clean if necessary.

Condenser Coils

Grass cuttings, leaves, dirt, dust, lint from clothes dryers, and fall off from trees can be drawn into coils by movement

of the air. Clogged condenser coils will lower the efficiency of your unit and could cause damage to the condenser.

Periodically, debris should be brushed from the condenser coils.

WARNING

SHARP OBJECT HAZARD!

Condenser coils have sharp edges. Wear adequate body protection on body extremities (e.g. gloves).

FAILURE TO FOLLOW THIS WARNING COULD RESULT IN BODILY INJURY.

Use a soft bristle brush with light pressure only. DO NOT damage or bend condenser coil fins. Damaged or bent fins may affect unit operation.

Painted Surfaces

For maximum protection of the unit's finish, a good grade of automobile wax should be applied every year. In geographical areas where water has a high concentration of minerals (calcium, iron, sulfur, etc.). It is recommended that lawn sprinklers not be allowed to spray the unit. In such applications, the sprinklers should be directed away from the unit. Failure to follow this precaution may result in premature deterioration of the unit finish and metal components.

In sea coast areas, special maintenance is required due to the corrosive atmosphere provided by the high salt concentration in ocean mists and the air. Periodic washing of all exposed surfaces and coil will add additional life to your unit. Please consult your installing dealer for proper procedures in your geographic area.

IF YOUR SYSTEM DOES NOT WORK, BEFORE REQUESTING A SERVICE CALL:

1. Ensure thermostat is set below (cooling) or above (heating) room temperature and that the system lever is in the "COOL", "HEAT" or "AUTO" position.
2. Inspect your return air filter: If it is dirty your air conditioner may not function properly.
3. Check indoor and outdoor disconnect switches. Confirm circuit breakers are ON or that fuses have not blown. Reset breakers/replace fuses as necessary.
4. Inspect the outdoor unit for clogged condenser coils, (grass cuttings, leaves, dirt, dust or lint). Ensure that branches, twigs or other debris are not obstructing the condenser fan.

IF YOUR SYSTEM STILL DOES NOT OPERATE, CONTACT YOUR SERVICING DEALER.

Be sure to describe the problem, and have the model and serial numbers of the equipment available.

If warranted replacements parts are required, the warranty must be processed through a qualified distribution location.