

Figure 6. Applying Foil Tape to Drip Shield

11. Apply foil tape to entire length of drip shield to seal unused engaging holes (see figure 6).
 - a The foil tape should adhere to the bottom of the filter rack seal, wrap over and adhere to the top of the drip shield.
 - b The screws used to install the drip shield will protrude through the tape.
12. Reinstall filter rack using the same engaging holes as in step 4.
13. Apply sealant to the location shown in figure 7. Completely fill the gap where the drip shield extends through the coil support.

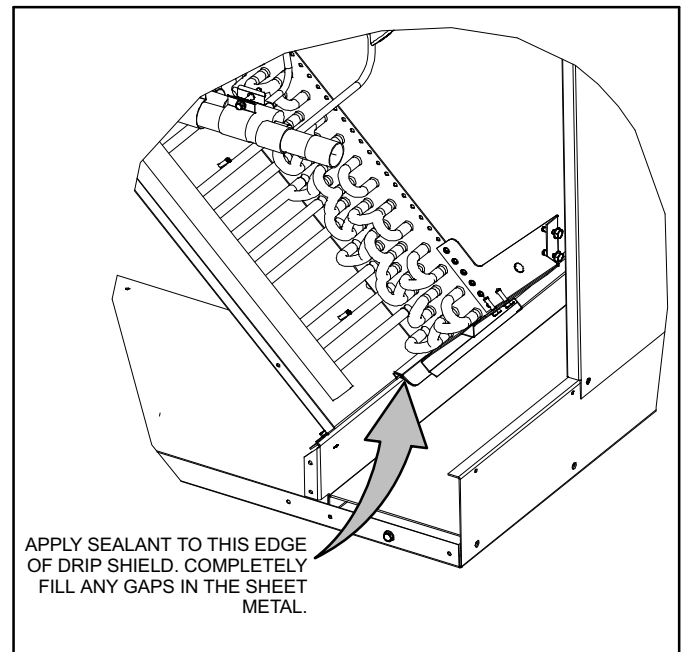

Figure 7. Applying Sealant to Drip Shield Edge

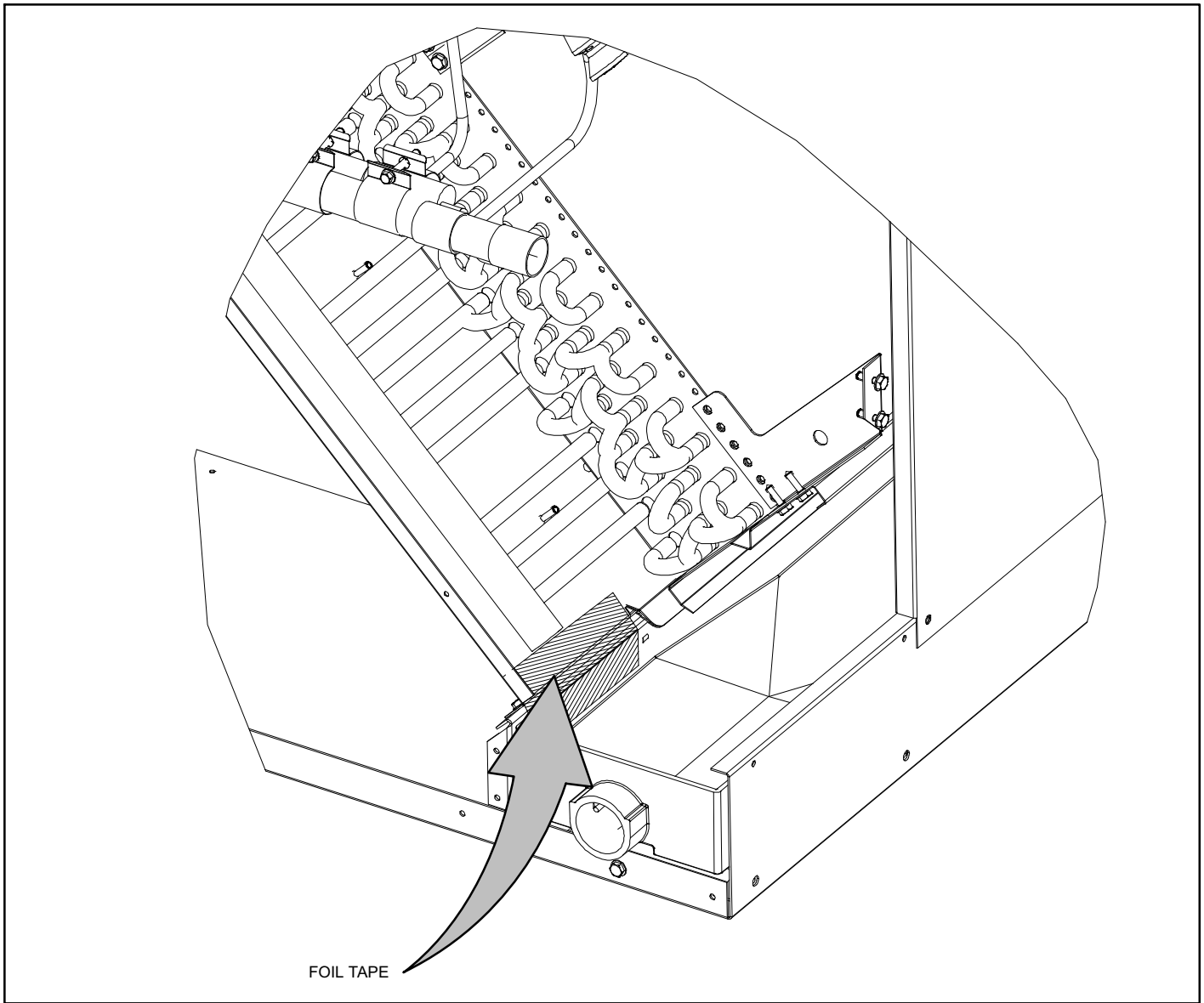

Figure 8. Applying Foil Tape to Coil Support

14. Apply foil tape to coil support under manifolding (see figure 8).

NOTE - It may be necessary to clean the sheet metal and drain pan before applying the tape.

15. Reinstall filters.

16. Replace filter access panels.

17. Restore power to unit.