

INSTALLATION INSTRUCTIONS FOR HIGH ALTITUDE LP/PROPANE KIT (78W96) USED FOR EL296 AND 95AF2 GAS FURNACES

⚠ WARNING

In the U.S., this conversion kit is to be installed by a licensed professional service technician (or equivalent) or other qualified agency in accordance with the manufacturer's instructions and all codes and requirements of the authority having jurisdiction. If the information in these instructions is not followed exactly, a fire, an explosion, or production of carbon monoxide may result, causing property damage, personal injury or loss of life. The qualified agency is responsible for the proper installation of the kit. The installation is not proper and complete until the operation of the converted furnace is checked as specified in the furnace manufacturer's instructions supplied with the kit.

Shipping & Packing List

Package 1 of 1 contains the following:

- 12 - Main burner orifices (0.032)
- 2 - LP/Propane regulator springs
- 1 - Gas converter sticker
- 1 - Nameplate conversion sticker

Application

Units installed in applications of 7501-10,000 ft require installation of a replacement gas valve regulator spring and gas orifices. Some units may require a pressure switch change, which is ordered separately. See unit installation instructions.

Installation

⚠ CAUTION

As with any mechanical equipment, personal injury can result from contact with sharp sheet metal edges. Be careful when you handle this equipment.

- 1 - Set the thermostat to the lowest setting. Shut off the gas supply to the furnace, then turn off the electrical power at the unit disconnect switch.
- 2 - Remove the access panel. Move the automatic gas valve switch to **OFF**. See figure 3.
- 3 - Disconnect the gas supply from the gas valve. Disconnect the wiring harness at the gas valve.

⚠ DANGER

Danger of explosion.

There are circumstances in which odorant used with LP/propane gas can lose its scent. In case of a leak, LP/propane gas will settle close to the floor and may be difficult to smell. An LP/propane leak detector should be installed in all LP applications.

- 4 - Remove the screw that secures the burner box front cover and remove front cover. See figure 1.
- 5 - Remove the four manifold securing screws. Remove the manifold/gas valve assembly. Figure 1 shows burner manifold assembly.
- 6 - Replace the main burner orifices with the provided orifices. Torque to approximately 35 in-lbs.

NOTE - LP/Propane orifices will be labeled (LP .032).

⚠ IMPORTANT

DO NOT use pipe dope or any pipe sealant on gas orifice threads.

- 7 - Reinstall the manifold/valve assembly and the burner box cover. Re-connect wiring harness to the gas valve.
- 8- **Replacing the high fire and low fire regulator springs**
 - a - Remove both high fire and low fire springs from the gas valve. See figure 2.
 - b - Replace both high fire and low fire springs with the provided LP springs color-coded white.
 - c - Install the high fire adjustment screw and adjust approximately 12 turns.
 - d - Install the low fire adjustment screw and adjust approximately 8 turns.
 - e - Install both regulator screw covers.
- 9 - Reconnect the gas supply line to the gas valve and turn on gas supply to unit.
- 10 - On the nameplate conversion sticker, mark the appropriate box that corresponds to the unit model number. Affix the sticker next to unit nameplate.
- 11 - Complete the information required on the converter sticker: date, name, and address. Affix sticker to the exterior of the unit in a visible area.
- 12 - Adjust high fire and low fire regulators and inspect for proper operation following the steps in the Start-Up & Adjustment section.

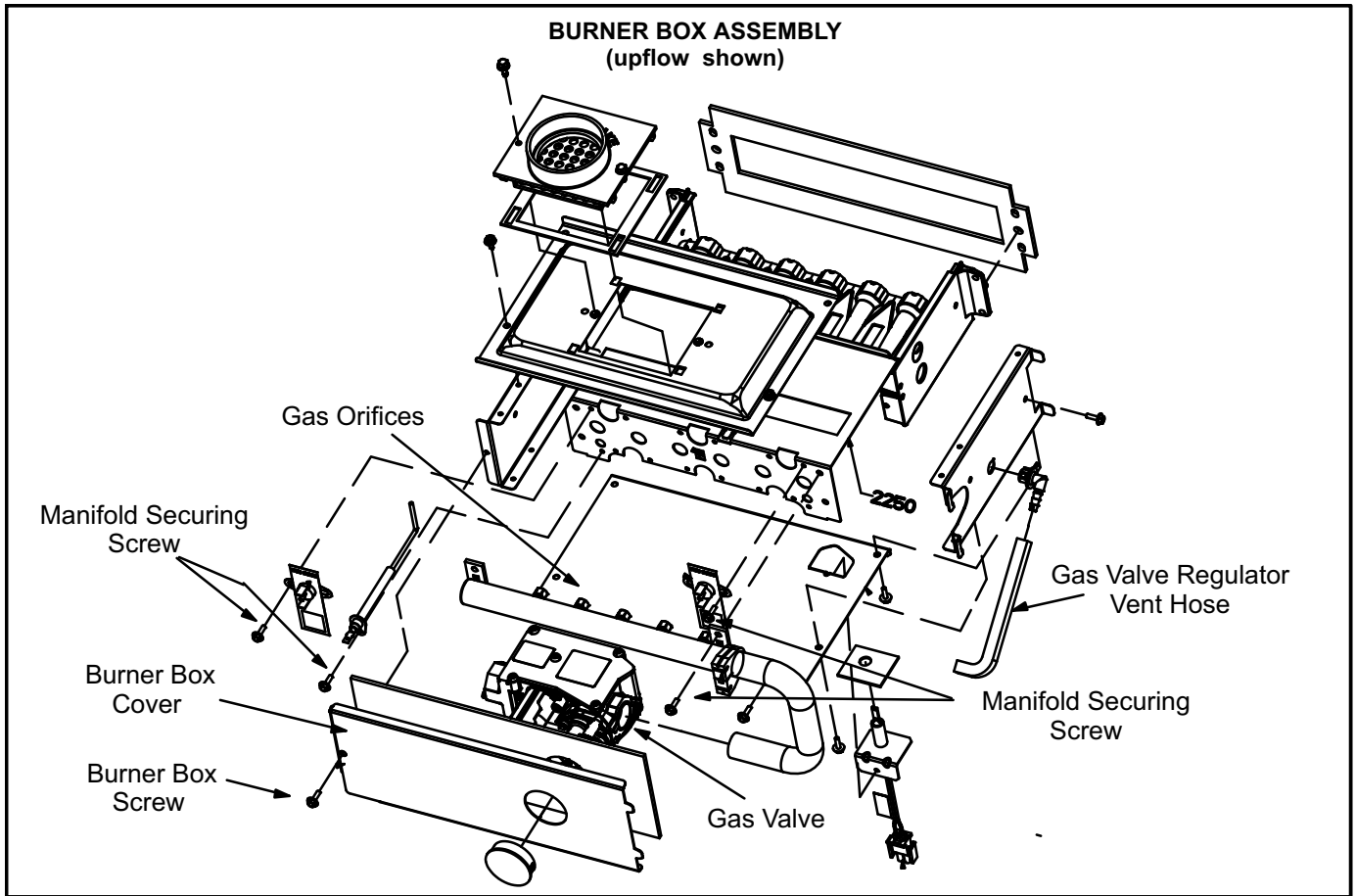

FIGURE 1

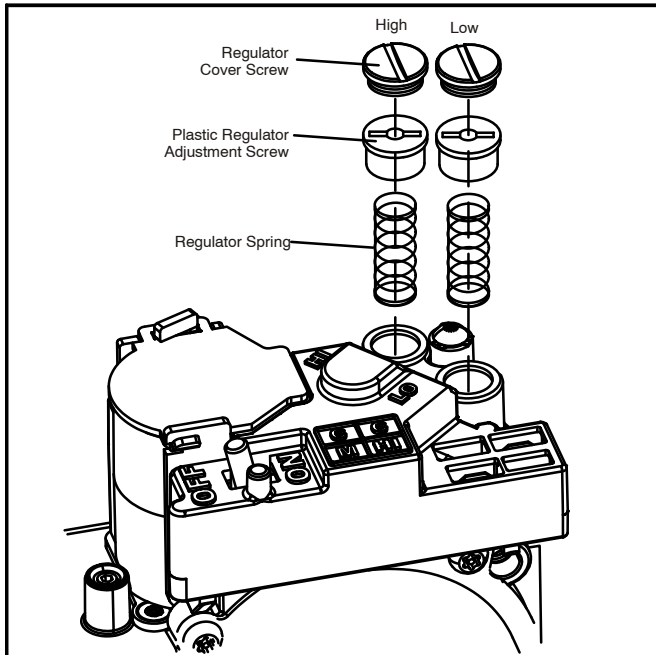

FIGURE 2

⚠ IMPORTANT

Carefully check all piping connections at the valve for gas leaks. **DO NOT** use matches, candles, open flames or other means of ignition to check for gas leaks. Use a soap solution or other preferred means.

⚠ CAUTION

Some soaps used for leak detection are corrosive to certain metals. Carefully rinse piping thoroughly after leak test has been completed. Do not use matches, candles, flame or other sources of ignition to check for gas leaks.

Start-Up & Adjustment

⚠ CAUTION

Gas valve conversion kit **MUST** be installed **BEFORE** the unit is fired using LP/propane gas. Unit damage **WILL OCCUR** if the unit is fired using LP/propane gas with the original natural gas orifices.

BEFORE PLACING THE UNIT INTO OPERATION -

Smell all around the appliance area for gas. Be sure to smell next to the floor because some gas is heavier than air and will settle on the floor.

Use only your hand to move the gas control switch. Never use tools. If the switch will not move by hand, do not try to repair it. Force or attempted repair may result in a fire or explosion.

A - Placing the Unit into Operation

⚠ IMPORTANT

Follow the lighting instructions provided on the unit. If lighting instructions are not available, refer to the following section.

Units are equipped with a integrated ignition system. The integrated ignition control automatically lights the burners each time the thermostat calls for heat.

- 1 - **STOP!** Read the safety information at the beginning of this section.
- 2 - Set the thermostat to its lowest setting.
- 3 - Turn off all electrical power to the furnace.
- 4 - Do **not** try to light the burners by hand.
- 5 - Remove the unit access panel.
- 6 - Move the switch on the gas valve to **OFF**. Do not force the switch. See figure 3.

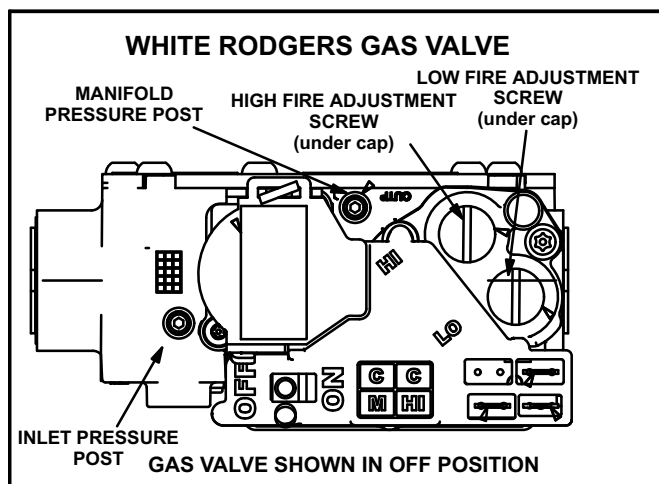

FIGURE 3

7 - Wait five (5) minutes for any gas to clear out. If you then smell gas, **STOP!** Immediately call your gas supplier from a neighbor's phone. Follow the gas supplier's instructions. If you do not smell gas, go to the next step.

8 - Move the switch on the gas valve to **ON**.

9 - Replace the unit access panel.

10 - Turn on all electrical power to the unit.

11 - Set the thermostat to desired setting.

12 - If the furnace will not operate, see section E- "Turning Gas Off to the Unit" and call the gas supplier.

Gas Pressure Measurement

NOTE - To obtain accurate reading, shut off all other gas appliances connected to meter.

A - Gas Flow (Approximate)

Furnace should operate at least 5 minutes before checking gas flow. Determine time in seconds for **two** revolutions of gas through the meter. (Two revolutions assures a more accurate time.) **Divide by two** and compare to time in table 1 below. If manifold pressure matches table 2 and rate is incorrect, check gas orifices for proper size and restriction. Remove temporary gas meter if installed.

TABLE 1
High Fire Only

Unit Capacity	GAS METER CLOCKING CHART	
	Seconds for One Revolution	
	LP	
	1 cu ft Dial	2 cu ft DIAL
-045	227	455
-070	152	304
-090	114	228
-110	91	182
-135	76	152

LP-2500 btu/cu ft

B - Supply Pressure Measurement

An inlet pressure post located on the gas valve provides access to the supply pressure. See figure 3. Back out the 3/32 hex screw one turn, connect a piece of 5/16 tubing and connect to a manometer to measure supply pressure. Check supply pressure with unit on high fire. On multiple unit installations, check each unit separately and with other units operating. See table 2 for supply line pressure. Following supply pressure test, shut off unit, remove manometer and tighten pressure post hex screw.

C - Measuring & Adjusting the Manifold Pressure

NOTE - Pressure test adapter kit (10L34) is available from Lennox to facilitate manifold pressure measurement.

A manifold pressure post located on the gas valve provides access to the manifold pressure. See figure 3. Back out the 3/32 hex screw one turn, connect a piece of 5/16 tubing and connect to a manometer to measure manifold pressure.

To correctly measure manifold pressure, the differential pressure between the positive gas manifold and the negative burner box must be considered. Furnace should operate at least 5 minutes before checking manifold pressure.

- 1 - Connect the test gauge positive side "+" to manifold pressure tap on gas valve as noted above.
- 2 - Tee into the gas valve regulator vent hose and connect to test gauge negative "-".
- 3 - Ignite unit on low fire and let run for 5 minutes to allow for steady state conditions.
- 4 - After allowing unit to stabilize for 5 minutes, record low fire manifold pressure and compare to value given in table 2. If necessary, make adjustment. Figure 3 shows location of low fire adjustment screw.
- 5 - Repeat on high fire and compare to value given in table 2. If necessary, make adjustment. Figure 3 shows location of high fire adjustment screw.
- 6 - Shut unit off and remove manometer as soon as an accurate reading has been obtained. Take care to replace pressure tap plug.
- 7 - Start unit and perform leak check. Seal leaks if found.

TABLE 2
Manifold and Gas Line Pressure (inches w.c.)

Gas	Manifold Pressure		Supply Line Pressure	
	Low Fire	High Fire	Min	Max
LP/ Propane	4.9	10.0	11.0	13.0

D- Proper Combustion

Furnace should operate minimum 15 minutes with correct manifold pressure and gas flow rate before checking combustion. Take combustion sample beyond the flue outlet. See tables 3 and 4.

NOTE - Shut unit off and remove manometer as soon as supply line pressure, manifold pressure and combustion sample have been obtained. Take care to replace pressure tap plug.

TABLE 3

All Up-flow Models	CO ₂ % For L.P	
	Low Fire	High Fire
045	6.4 - 7.4	8.8 - 9.8
070	6.3 - 7.3	8.7 - 9.7
090	6.8 - 7.8	8.9 - 9.9
110	7.1 - 8.1	9.3 - 10.3
135	7.1 - 8.2	9.1 - 10.1
The maximum carbon monoxide reading should not exceed 100 ppm.		

TABLE 4

All Down-flow Model	CO ₂ % For L.P	
	Low Fire	High Fire
045	6.6 - 7.6	9.1 - 10.1
070	6.5 - 7.5	8.6 - 9.6
090	6.9 - 7.9	9.1 - 10.1
110	7.3 - 8.3	9.5 - 10.5
The maximum carbon monoxide reading should not exceed 100 ppm.		

E - Turning Off Gas To the Unit

- 1 - Set the thermostat to its lowest setting.
- 2 - Turn off all the electrical power to the unit.
- 3 - Remove the unit access panel.
- 4 - Move the switch on the gas valve to **OFF**. Do not force the switch.