



©2016 Lennox Industries Inc.
Dallas, Texas, USA

**INSTALLATION INSTRUCTIONS FOR REPLACEMENT DEFROST CONTROL KIT (15D57)
USED WITH VARIOUS HEAT PUMPS**

TABLE OF CONTENTS

Shipping and Packing List 1
 Application 1
 Installation 2
 References 2
 Sequence of Operations 5
 Operational Description 7
 Diagnostics, Sensors and Test 9
 Terminal Wiring 15

! IMPORTANT

Improper installation, adjustment, alteration, service or maintenance can cause personal injury, loss of life, or damage to property.

Installation and service must be performed by a licensed professional installer (or equivalent) or a service agency.

! IMPORTANT



Electric Shock Hazard. Can cause injury or death. Unit must be grounded in accordance with national and local codes.

Line voltage is present at all components when unit is not in operation on units with single-pole contactors. Disconnect all remote electric power supplies before opening access panel. Unit may have multiple power supplies.

Shipping and Packing List

Package 1 of 1 contains:

- 1 - Defrost control (100135-07)
- 1 - Defrost sensor harness (101334-02)
- 1 - Defrost control sticker (401,205S)

Application

Replacement defrost control kit 15D57 (614943-02) includes defrost control 100135-07. This defrost control may be used in various heat pump units to replace any defrost control listed in table 1. If the unit was originally equipped with any defrost control other than a 100135 series, operation should be reviewed at the time of replacement.

Table 1. Applicable Defrost Controls to be Replaced

Original Defrost Control	Heat Pump Model / Build Number	Defrost Sensor Harness Required
10M8901	HP27, build -04P and -06P	Yes
60L3901, 46M8201 or 56M8501	HPXA12, builds -01, -02 and -03	Yes
	HPXA19, builds -01, -02, -03, and -05	Yes
	HP27, build -6P	Yes
	SPA36H4, build -02	Yes
	SPA48H4, build -02	Yes
	SPA60H4, build -02	Yes
100135-01 (86M38) 100135-02 (86M38) 100135-03 (40W00) 100135-04 (41W72) 100135-05 (42W04) 100135-06 (81W99)	HPXA16 (all)	No
	14HPX, builds -01, -02, -10, -11, -12, -13, -14	No
	XP14, builds -01, -02, -03 and -04	No
	XP15, builds -01, -02, -03 and -04	No
	XPG15, builds -01, -02, -03 and -04	No
	XP16, builds -01, -02, -03, -04, -05, -06 and -07	No
	XP19, builds 01, -02, -03 and -05.	No
	XPG20, build -01	No
	SPB36, SPB48 and SPB60, builds -01, -02, -04, -06 and -07	No
	TPA036, TPA042, TPA048, and TPA060, builds -01 and -10	No



Installation

1. Use the Wire Color column in the following table to record the wire colors that are connected to the original defrost control terminals for use when reconnecting.

Table 2. Write Down Wire Colors Before Disconnecting

Terminals	Wire Color
Inputs - screw terminal strip connections	
R - 24VAC input power	
C - 24VAC <i>common</i>	
Y1 - First-stage compressor 24VAC input	
Y2 - Second-stage compressor 24VAC input	
O - Reversing valve 24VAC input	
W1 - Auxiliary heat 24VAC output	
L - 24VAC service light output	
T - 24VAC ambient compensator output	
1/4 quick connect terminals	
HI-PS - High-pressure switch	
HI-PS - High-pressure switch	
LO-PS - Low-pressure switch	
LO-PS - Low-pressure switch	
O - 24VAC output to reversing valve	
O Out - 24VAC output <i>common</i> to reversing valve	
Y1 - 24VAC to contactor for first stage compressor	
Y1 - 24VAC <i>common</i> to contactor for first-stage compressor	
Y2 - 24VAC to second-stage compressor solenoid	
Y2 - 24VAC <i>common</i> to second-stage compressor solenoid	
FAN - 240VAC into outdoor fan relay contacts on defrost control	
FAN - 240VAC out of outdoor fan relay contacts on defrost control	
L - 24VAC terminal for service thermostat	
W - 24VAC terminal for service thermostat	
T - 24VAC ambient compensator output	
T - 24VAC ambient compensator output	
C - 24VAC common	
24V - 24VAC common	

2. If applicable, install new coil and outdoor ambient sensors in the same location as the old sensors and route harness back to new defrost control.
3. Install provided defrost code sticker to access panel.

IMPORTANT

Keep wires away from hot surfaces and sharp edges.

4. Refer to the Sequence of Operations section on page 5 to check out operations of new defrost control.

References

This section provides reference to defrost control features, terminals and defrost control layouts.

Table 3. Demand Defrost Control Features by Catalog Number

Features	10M8901	60L3901	46M8201	56M8501	100135
Self Calibrating principles in order to calibrate itself	Y	Y	Y	Y	Y
On-board switching outdoor fan relay (contacts normal closed)	Y	Y	Y	Y	Y
Anti-short cycle delay (minimum off time of 5 minutes)	Y	Y	Y	Y	Y
High Pressure (HI-PS) fault	Y	Y	Y	Y	Y
High Pressure (HI-PS) lockout (3 or 5 strike)	3	3	3	5	5
Low Pressure (LO-PS) fault	Y	Y	Y	Y	Y
Low Pressure (LO-PS) lockout (3 or 5 strike)	3	3	3	5	5
Ambient sensor fault detection	Y	Y	Y	Y	Y
Coil sensor fault detection	Y	Y	Y	Y	Y
High discharge line temperature (DIS) fault	N	N	N	N	Y
High discharge line temperature (DIS) lockout (3 or 5 strike)	N	N	N	N	5
Defrost pressure termination pins	Y	Y	Y	N	N
Y2 terminal connection (Later versions of 60L3901)	N	N	Y	Y	Y
Compressor Lock in Temperature	N	N	N	N	Y
Compressor Delay option going in and out of defrost (30 seconds)	N	N	N	Y	Y

Table 4. Demand Defrost Control Terminals by Catalog Numbers

Terminals	10M8901	60L3901	46M8201	56M8501	100135
Inputs - screw terminal strip connections					
R - 24VAC input power	x	x	x	x	x
C - 24VAC <i>common</i>	x	x	x	x	x
Y1 - First-stage compressor 24VAC input	x	x	x	x	x
Y2 - Second-stage compressor 24VAC input			x	x	x
O - Reversing valve 24VAC input	x	x	x	x	x
W1 - Auxiliary heat 24VAC output	x	x	x	x	x
L - 24VAC service light output	x	x	x	x	x
T - 24VAC ambient compensator output	x	x			
1/4 quick connect terminals					
HI-PS - High-pressure switch	x	x	x	x	x
HI-PS - High-pressure switch	x	x	x	x	x
LO-PS - Low-pressure switch	x	x	x	x	x
LO-PS - Low-pressure switch	x	x	x	x	x
O - 24VAC output to reversing valve	x	x	x	x	x
O Out - 24VAC output <i>common</i> to reversing valve	x	x	x	x	x
Y1 - 24VAC to contactor for first stage compressor	x	x	x	x	x
Y1 - 24VAC <i>common</i> to contactor for first-stage compressor	x	x	x	x	x
Y2 - 24VAC to second-stage compressor solenoid			x	x	x
Y2 - 24VAC <i>common</i> to second-stage compressor solenoid					x
FAN - 240VAC into outdoor fan relay contacts on defrost control	x	x	x	x	x
FAN - 240VAC out of outdoor fan relay contacts on defrost control	x	x	x	x	x
L - 24VAC terminal for service thermostat	x	x	x	x	x
W - 24VAC terminal for service thermostat			x	x	
T - 24VAC ambient compensator output	x	x			
T - 24VAC ambient compensator output		x			
C - 24VAC common	x	x	x	x	
24V - 24VAC common					x
10M8901, 60L3901, 46M8201 and 56M8501 demand defrost control's ambient and coil sensors can not be detached from defrost control. Connections are soldered.					
100135 demand defrost control ambient and coil sensors are connected to defrost control by a 6-pin plug					
COIL - Ground connection for outdoor coil temperature sensor (Location in plug - P4-1)					x
COIL - Connection for outdoor coil temperature sensor (Location in plug - P4-2)					x
AMB - Ground connection for ambient temperature sensor (Location in plug - P4-3)					x
AMB - Connection for ambient temperature sensor (Location in plug - P4-4)					x
DIS - Ground connection for discharge line temperature sensor (Location in plug - P4-5). Not applicable to single-stage application. Resistor install between P4-5 and P4-6 on defrost sensor harness connector.					x
DIS - Connection for discharge line temperature sensor (Location in plug - P4-6). Not applicable to single stage application. Resistor install between P4-5 and P4-6 on defrost sensor harness connector.					x

Demand Defrost Control Layouts

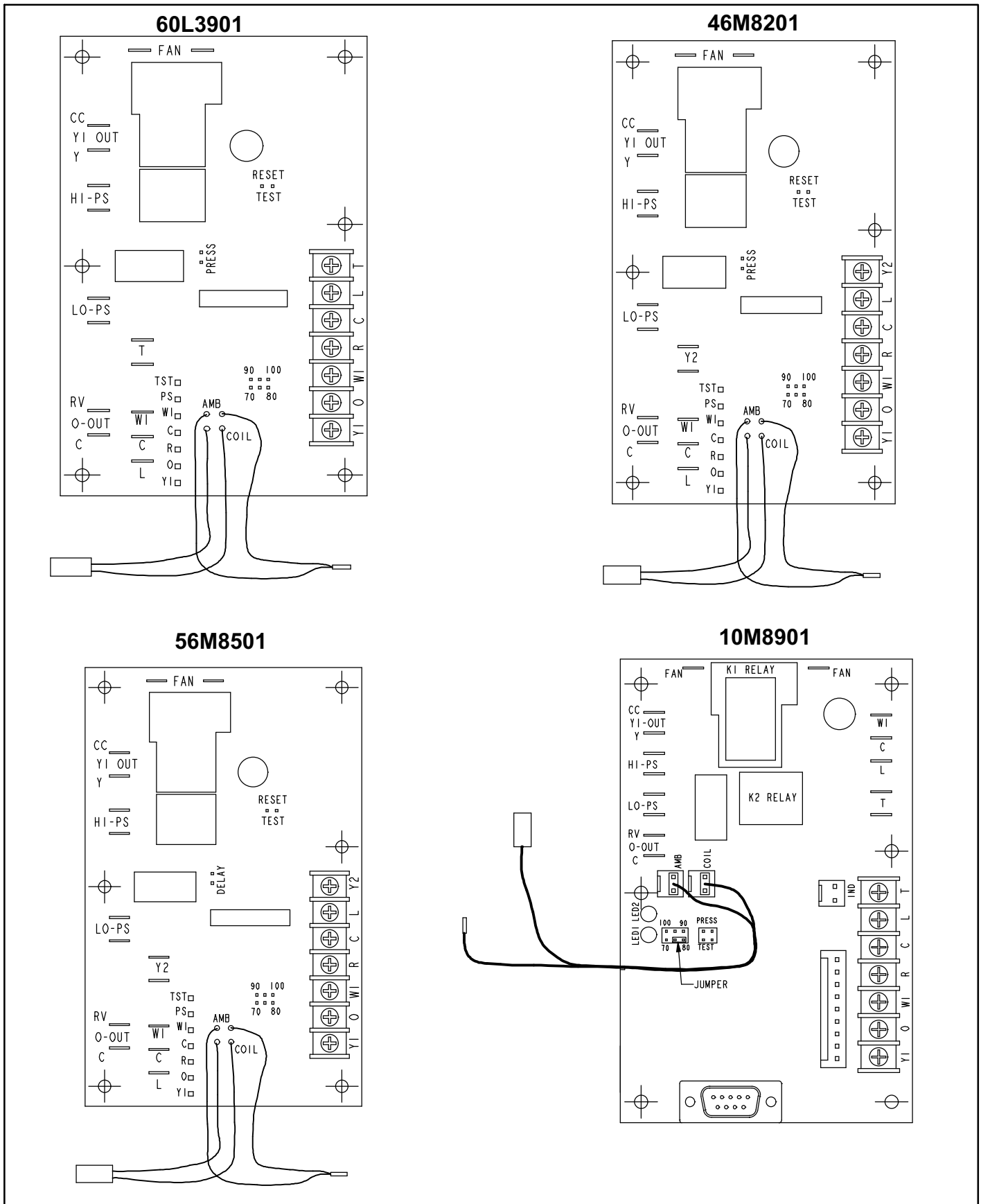

Figure 1. Applicable Defrost Controls

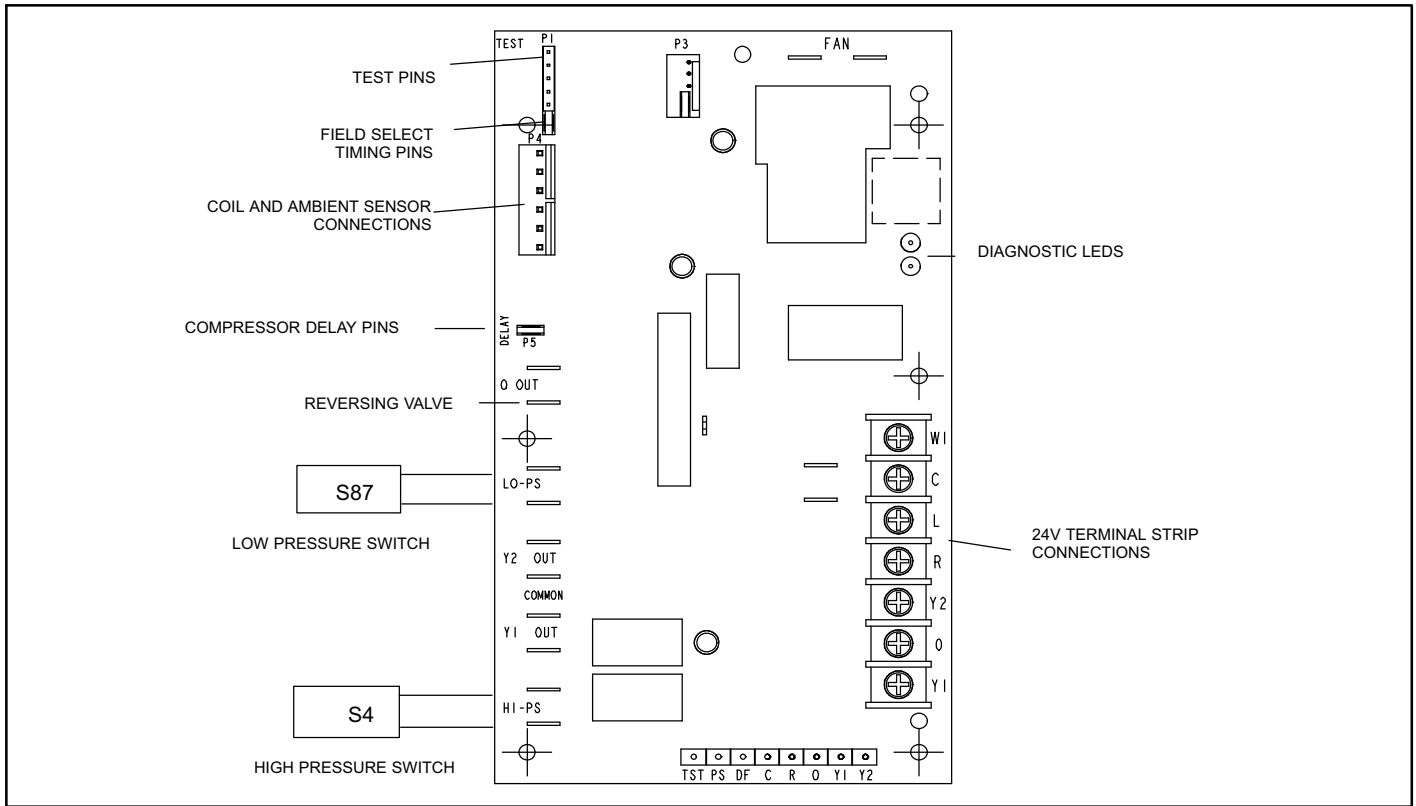

Figure 2. Defrost Control (100135-07)

Sequence of Operations

FIRST-STAGE COMPRESSOR OPERATION — ALL DEMAND DEFROST CONTROLS

If the demand defrost control receives a call for first-stage compressor operation **Y1**, in heating or cooling, the compressor contactor output **Y1 OUT** will be energized immediately, or immediately after the anti-short cycle delay timer has expired, whichever occurs last. The demand defrost control shall de-energize the contactor output immediately when the **Y1** signal is removed.

SECOND-STAGE COMPRESSOR OPERATION

Demand Defrost Controls — 46M8201 and 56M8501

If the demand defrost control receives a call for second-stage compressor operation **Y2**, in heating or cooling mode, the second-stage compressor solenoid output will be energized.

If the first-stage compressor output is active *in heating mode* and the outdoor ambient temperature is below the low ambient thermostat (S23) setting, the second-stage compressor solenoid output will be energized without the **Y2** input. The adjustable control is set from the factory to close at 40°F and open at 50°F. The demand defrost control will de-energize the second-stage compressor solenoid output immediately when the **Y2** signal is removed or the outdoor ambient temperature is 10°F above the selected low outdoor ambient thermostat setting.

Demand Defrost Control — 100135

If the demand defrost control receives a call for second-stage compressor operation **Y2** in heating or cooling mode and the first-stage compressor output is active, the second-stage compressor solenoid output will be energized.

If the first-stage compressor output is active *in heating mode* and the outdoor ambient temperature is below the selected compressor lock-in temperature, the second-stage compressor solenoid output will be energized without the **Y2** input. If the jumper is not connected to one of the temperature selection pins on P3 (40°F, 45°F, 50°F, Ξ), the default lock-in temperature of **40°F** will be used. When the jumper is connected to the three-bar symbol, the second stage lock-in is turned off.

The demand defrost control shall de-energize the second-stage compressor solenoid output immediately when the **Y2** signal is removed or the outdoor ambient temperature is 5°F above the selected compressor lock-in temperature, or the first-stage compressor output is de-energized for any reason.

ANTI-SHORT CYCLE DELAY — ALL DEMAND DEFROST CONTROLS

The demand defrost control protects the compressor from short cycling (five minutes) when there is initial power up, an interruption in power to the unit, pressure or sensor trips or for five minutes after **Y1** demand is removed. (*The TEST terminals on the board can be shunted (jumpered) between 1 to 2 seconds to bypass delay*)

DEFROST TEMPERATURE TERMINATION JUMPER PINS

The demand defrost control can be set to terminate defrost at four different temperature pin settings:

Demand Defrost Controls — 10M8901, 60L3901, 46M8201 and 56M8501

Selections are - 70°F, 80°F, 90°F and 100°F (21°C, 27°C, 32°C and 38°C). *The shunt termination pin is factory set at 90°C (32°C).* (If the shunt is not installed, the default termination temperature is **100°F**).

Demand Defrost Control — 100135

Selections are - 50°F, 70°F, 90°F, and 100°F (10°C, 21°C, 32°C and 38°C). *The shunt termination pin is factory set at 50°F (10°C).* If the temperature shunt is not installed, the default termination temperature is **90°F**.

NOTE — *Different climatic regions may required different defrost termination settings.*

PRESSURE AND / OR TEMPERATURE SWITCH PROTECTION CIRCUITS — ALL DEMAND DEFROST CONTROLS

The demand defrost control incorporates protection circuits that allow the application of additional pressure and/or temperature switches.

IMPORTANT — *If a pressure switch is not connected to the LO-PS or HI-PS spade terminals, a jumper wire is required across these terminals for proper demand defrost control operation.*

High-Pressure Terminals (All demand defrost controls)

The automatic reset high-pressure switch (S4) is factory wired into the HI-PS terminals. The path between **Y1** (input from room thermostat) and **Y1 Out** is interlocked through the high-pressure switch. When the high-pressure switch trips, the demand defrost control will cycle off the compressor and the strike counter in the demand defrost control will count one strike. *(Within a single room thermostat demand, if 3-strikes occur on the 10M8901, 60L3901, 46M8201 or 5-strikes on the 56M8201 and 100135, the demand defrost control will lockout the unit. demand defrost control 24 volt power **R** must be cycled **OFF** or the **TEST** pins on demand defrost control must be shorted between 1 to 2 seconds to reset the demand defrost control).*

If the unit has no high pressure switch, a jumper must be placed on the high pressure switch terminals.

Low-Pressure Terminals (As noted)

No Pressure Switch on LO-PS Terminals: Requires the connection of a jumper wire across the LO-PS terminals.

- LO-PS operation function disabled.

Normal Pressure Input Operation: Requires the connection of a low-pressure switch to the LO-PS terminals. This configuration activates the following functions:

- 3-strike lockout feature (10M8901, 60L3901 and 46M8201)

- 5-strike lockout feature (56M8501 and 100135)
- LO-PS switch is ignored:
 - ✓ During the defrost cycle and 90 seconds after defrost cycle to allow the system pressures to return to normal levels.
 - ✓ For a period of 90 seconds following the start up of the compressor.
 - ✓ If the average ambient sensor temperature is below 15°F
 - ✓ While in **Test Mode**

During one room thermostat demand, if there are two low pressure trips, the 100135-07 defrost control can initiate a defrost.

The LO-PS terminals on **10M8901, 60L3901 and 46M8201** in conjunction with the two male pins marked **PRESS** can configure the control to the following operation:

Pressure Termination Operation:

Requires that a jumper be installed on the pins marked **PRESS**. The jumper is field supplied (Jumper kit – 38L94-10 pack). This option requires the installation of a new pressure switch (set to open at 325 psig and close at 260 psig – Part # 43G7801 for R-22. Set to open at 575 psig and close at 450 psig – Part # 32M0801 for R-410A) next to the factory installed high-pressure switch. This switch is connected to the LO-PS terminals and will allow the defrost cycle to terminate on pressure.

IMPORTANT: If the unit has a low-pressure switch or a factory jumper connected to the LO-PS terminals, disconnect and wire the new pressure switch to the LO-PS terminals.

This configuration activates the following functions:

- LO-PS is ignored during heating/cooling modes
- Coil termination temperatures are ignored during defrost
- 3-strike lockout feature shall be disabled for high and low pressure (60L3901 or 46M8201)
- During defrost operation the new pressure switch that is wired to LO-PS terminals will open and terminate defrost.
- If the defrost cycle terminates by time, the demand defrost control will operate in time/temperature mode.
- During defrost, if the coil temperature is above 35°F (2°C) for 4 minutes and defrost is terminated by pressure, if the demand defrost control is calibrated, it shall operate in demand mode.

DELAY OPERATION

Demand Defrost Control — 56M8501 and 100135

The delay option requires a jumper to be installed on the pins marked **DELAY**. When the jumper is in place, the compressor will cycle **OFF** for 30 seconds going in and out of defrost. **This feature is not enabled when the demand defrost control is in field TEST mode.**

These demand defrost controls **do** come from the factory with the jumper in place. If the **DELAY** jumper is absent, the 30 second compressor delays at the beginning and end of the defrost cycle will not be executed.

Operational Description

Normal demand defrost control Operation (All demand defrost control's)

Table 5. Room Thermostat Inputs

Demand Defrost Control Terminals	Cooling		Heating	
	1 st	2 nd	1 st	2 nd
R and C input power from indoor unit				
Y1 - First-stage compressor 24VAC input	x		x	
Y2 - Second-stage compressor 24VAC input		x		x
O - Reversing valve 24VAC input	x	x		
L - Service light output terminal on board	x	x	x	x
W1 - 24VAC output to indoor auxiliary electric heater when board is in defrost			x	x

DEFROST MODE (DEMAND DEFROST CONTROLS)

When a defrost cycle is initiated, the demand defrost control energizes the reversing valve solenoid and turns off the outdoor fan. The demand defrost control will also put 24 VAC on the **W1** (auxiliary heat) terminal.

The unit will stay in this mode until:

- The outdoor coil sensor temperature goes above the selected termination temperature. (If the temperature select jumper is not installed, the default termination temperature will be 100°F (38°C) on 10M8901, 60L3901, 46M8201, 56M8501 and 90°F (32°C) on 100135).
- The defrost time of 14 minutes has been completed.
- The room thermostat demand has been satisfied. (If the room thermostat demand cycle terminates before the defrost cycle is complete, the defrost cycle will be held until the next room thermostat demand cycle. If the coil sensor temperature is still below the selected termination temperature, the demand defrost control will continue the defrost cycle until defrost is terminated by one of the above methods. If the defrost

is terminated by time and the coil temperature did not remain above 35°F (2°C) for 4 minutes, the demand defrost control will go to the 30 minute Time/Temperature mode.

DEFROST CALIBRATION MODE

Demand Defrost Controls — 10M8901, 60L3901, 46M8201 and 56M8501

These demand defrost controls are considered un-calibrated at power up, after cooling operation or if the coil temperature exceeds the termination temperature when in the heat mode.

Demand Defrost Control — 100135

This demand defrost control is considered un-calibrated at power up and after cooling operation.

Calibration of the demand defrost control occurs after every defrost cycle to ensure there is no ice on the coil. During calibration, the temperature of both the coil and ambient sensor are measured to establish a clear coil condition.

DEMAND DEFROST OPERATION

The demand defrost control initiates a defrost cycle based on either frost detection or time.

Frost Detection — If the compressor runs longer than 30 minutes and the actual difference between the clear coil and frosted coil temperature exceeds the maximum difference allowed by the calibrated demand defrost control, a defrost will be initiated.

IMPORTANT — *The demand defrost control will allow a greater accumulation of frost and will initiate fewer defrost cycles than time/temperature defrost.*

Time — If six hours of heating mode compressor run time has elapsed since the last defrost cycle while the coil temperature remains below 35°F (2°C), the demand defrost control will initiate a defrost cycle.

The attached flow diagram shows the general flow of the demand defrost control when there are no faults. (Ex: low, high, discharge sensor, etc)

CALIBRATION MODE SEQUENCE

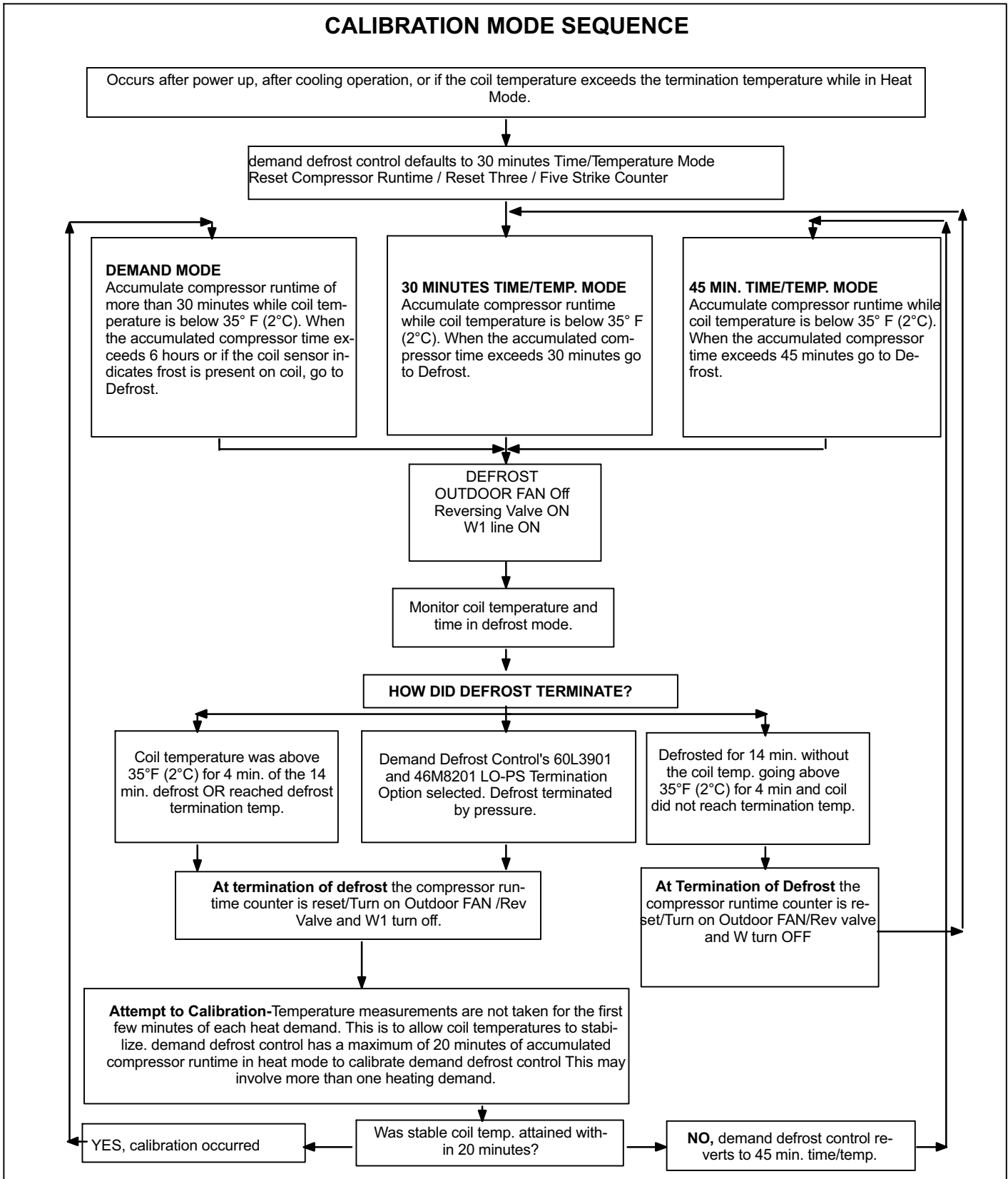

Figure 3. Calibration Mode Sequence

Diagnostics, Sensors and Test

Table 6. Defrost Controls — 10M8901, 60L3901, 46M8201 and 56M8501

Code Description	LED #1 (Red)	LED # 2 (Red)
No Power *	OFF	OFF
Normal Operation *	Simultaneous Flash	
Anti-short Cycle *	Alternate Flash	
Low-Pressure Switch Fault	ON	Flash
High-Pressure Switch Fault	Flash	ON
3 or 5 strike pressure-switch lockout	ON	OFF
Ambient Sensor Problem	OFF	ON
Coil Sensor Problem	ON	ON

Table 7. Demand Defrost Control — 100135

Code Description	DS2 (Green)	DS1 (Red)
No Power *	OFF	OFF
Normal Operation *	Simultaneous Slow Flash	
Anti-short Cycle *	Alternate Slow Flash	
Low-Pressure Switch Fault	OFF	Slow Flash
Low-Pressure Switch Lockout	OFF	ON
High-Pressure Switch Fault	Slow Flash	OFF
High-Pressure Switch Lockout	ON	OFF
High-Discharge Temperature Fault	Slow Flash	ON
High-Discharge Temperature Lockout	Fast Flash	ON
Ambient Sensor Problem	Simultaneous Fast Flash	
Coil Sensor Problem	Alternate Fast Flash	
Circuit Board Failure	ON	ON
Discharge Sensor Fault	OFF	Fast Flash
Discharge Sensor Lockout	Fast Flash	OFF

* Codes that are the same on all demand defrost controls.

Within a single room thermostat demand, if 3-strikes occur on the 10M8901, 60L3901 and 46M8201 or 5-strikes on the 56M8201 and 100135, the demand defrost control will lockout the unit.

Demand Defrost Control 24VAC power **R** must be cycled **OFF** or the **TEST** pins on demand defrost control must be shorted *between 1 to 2 seconds to reset the demand defrost control.*

DISCHARGE SENSOR FAULTS AND LOCKOUT (100135):

- Two-stage application (sensor applied): Indicates open sensor or temperature out of range of sensor.
- Single-stage application (resistor applied): Missing resistor between P4-5 and P4-6 in the discharge sensor harness

DEMAND DEFROST CONTROL FIELD TEST MODE (100135)

The **TEST** mode is engaged by placing a jumper across the **TEST** pins on the demand defrost control **after** power-up. The **TEST** pins are ignored and the test function is locked out if the shunt is applied on the **TEST** pins before power-up. demand defrost control timings are reduced, the low-pressure switch and loss of charge detection fault is ignored and the demand defrost control will clear any active lockout condition. Refer to flow chart below for **TEST** operation.

NOTE — The **Y1** input must be active **ON** and the **O** room thermostat terminal into board must be inactive.

TEST

Placing the jumper on the test pins allows the technician to:

- Clear short cycle lockout
- Clear five-strike fault lockout
- Cycle the unit in and out of defrost mode
- Place the unit in defrost mode to clear the coil

When Y1 is energized and 24V power is being applied to the Demand Defrost Control, a test cycle can be initiated by placing a jumper on the Demand Defrost Control's TEST pins for 2 to 5 seconds. If the jumper remains on the TEST pins for longer than five seconds, the Demand Defrost Control will ignore the jumpered TEST pins and revert to normal operation.

The control will initiate one test event each time a jumper is placed on the TEST pins. For each TEST the jumper must be removed for at least one second and then reapplied.

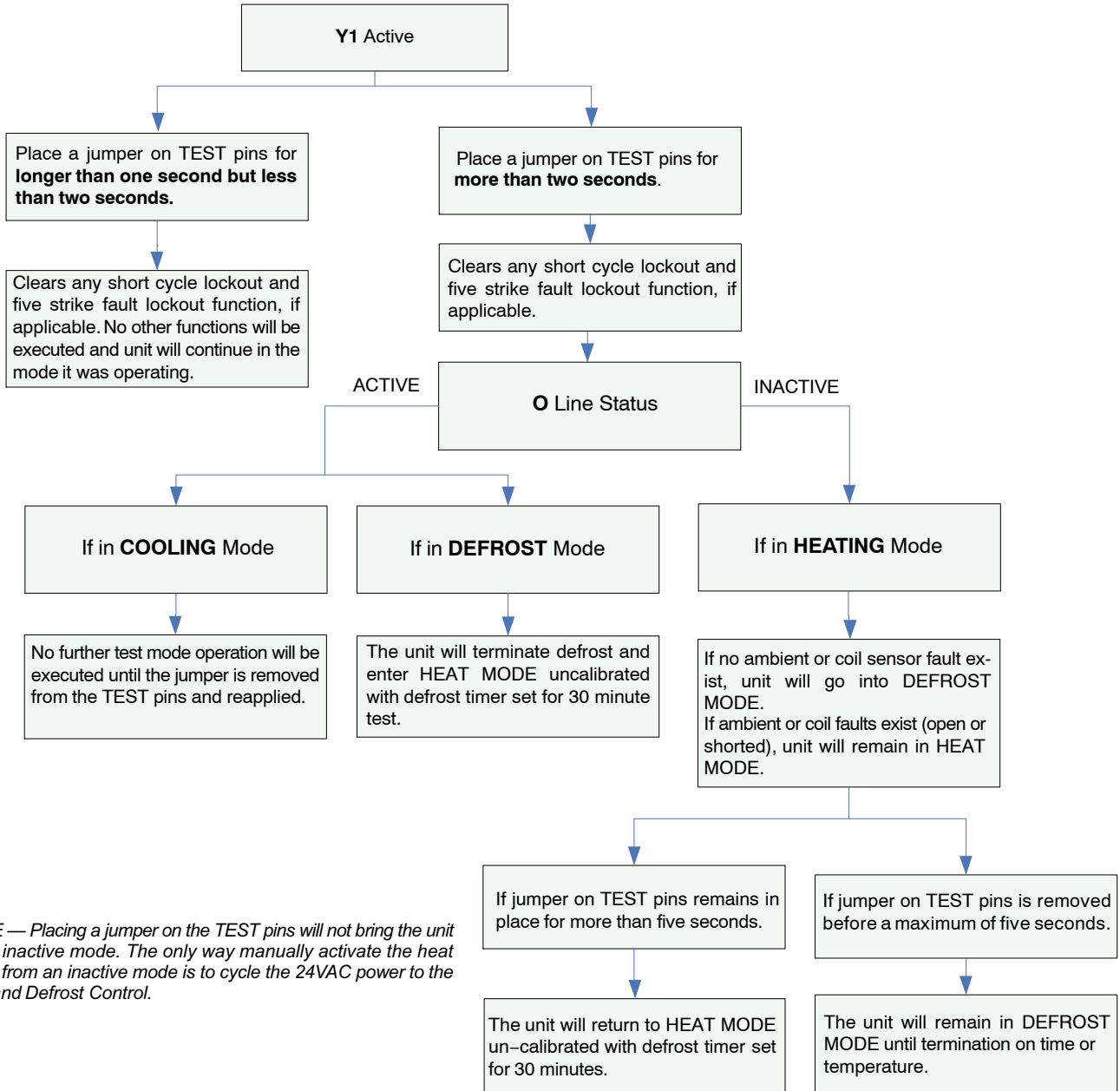
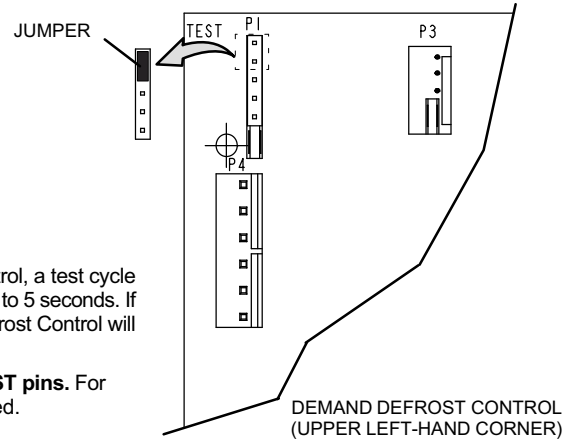

NOTE — Placing a jumper on the TEST pins will not bring the unit out of inactive mode. The only way manually activate the heat pump from an inactive mode is to cycle the 24VAC power to the Demand Defrost Control.

Figure 4. Test Mode (100135 Only)

COIL AND AMBIENT SENSORS

The sensors for the demand defrost control's 10M8901, 60L3901, 46M8201 and 56M8501 are internally and permanently attached to the inputs on the defrost control and are not field replaceable. The sensors for the demand defrost control 100135 uses a discharge sensor harness to plug into the defrost control P4 connector. See figure 6 for defrost sensor harness layout and connection to the 100135 defrost control.

Table 8. Sensor Specifications

Sensor	Temperature Ranges (F) (Sensor resistance increases as sensed temperature decreases)	Resistance values range (ohms)	Sensor Wire color
Coil sensor	-35°F (-37°C) to 120°F (48°C)	280,000 to 3750	Brown
Outdoor Ambient Sensor	-35°F (-37°C) to 120°F (48°C)	280,000 to 3750	Black

NOTE — Discharge line sensor is replaced with a resistor for single-stage unit applications.

Sensor resistance increases as the sensed temperature decreases (negative temperature coefficient thermistor). The demand defrost control is capable of detecting ambient, coil and discharge sensor fault conditions. If the sensor shows a fault, unplug sensors from demand defrost

control and ohm out each sensor. If a sensor shows shorted or open, replace complete discharge sensor harness. If sensor (s) still have resistance, reason for fault may be due to sensor being out of its temperature range. Sensor (s) replacement is not necessary. See figure 5 for sensor temperatures and Table 10 for resistance ranges.

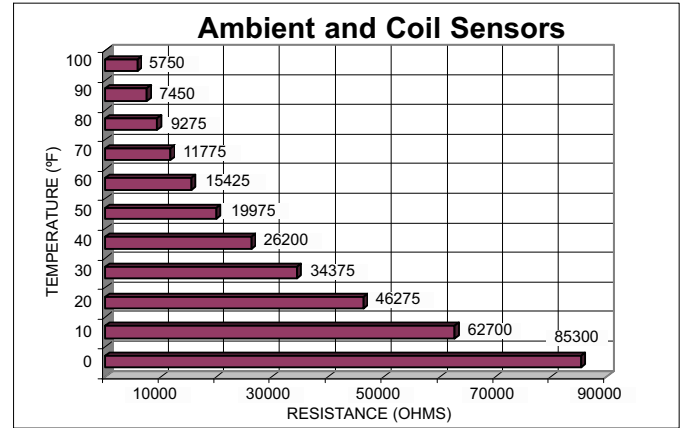

Figure 5. Sensor Temperatures

AMBIENT AND OUTDOOR COIL SENSORS

The demand defrost control 10M8901, 60L3901, 46M8201, 56M8501 and 10035 are capable of detecting ambient and/or coil fault conditions. See table 9.

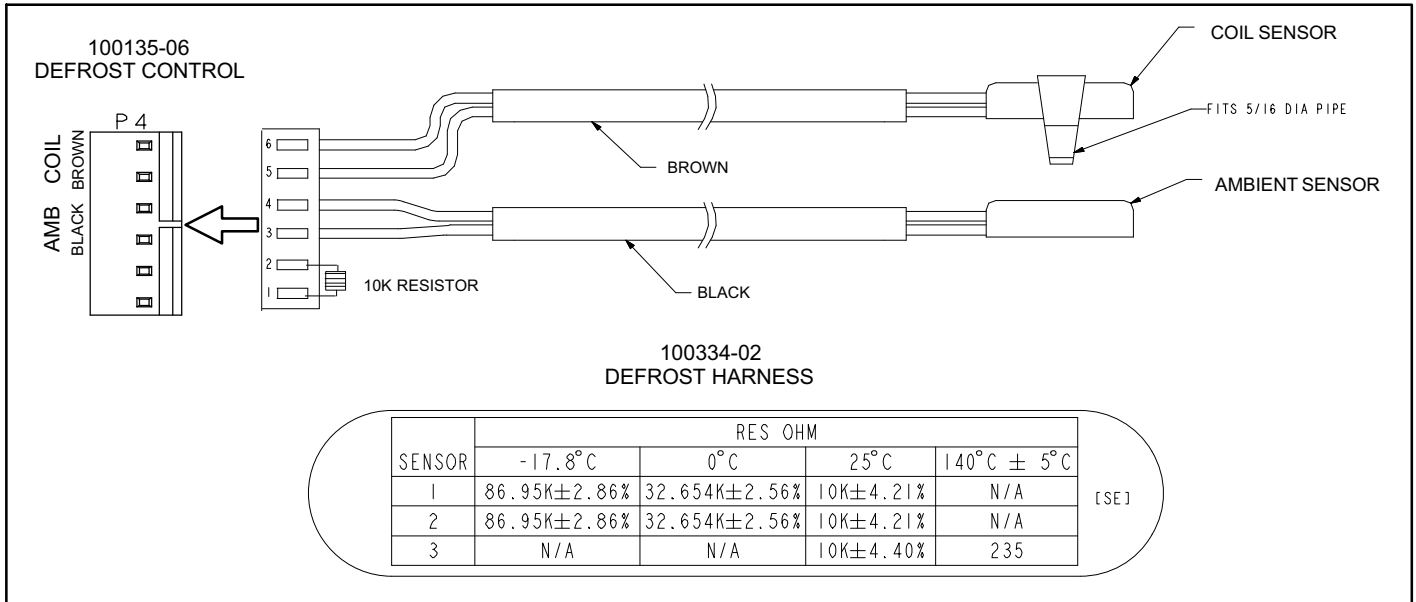

Figure 6. Defrost Sensor Harness (101334-02)

**Table 9. Sensors
Ambient Sensors**

Ambient Sensors		
Defrost Control	Ambient Sensor Fault°F (°C)	Result
10M8901	Below -20 (-28) or above 110 (43)	If the <u>ambient sensor</u> is detected as being open, shorted or out of the temperature range of the sensor, the demand defrost control will not perform demand defrost operation. The demand defrost control will revert to time/temperature defrost operation. The demand defrost control will display the appropriate fault code. <u>Heating and cooling operation will be allowed in this fault conditions.</u>
60L3901		
46M8201		
56M8501		
100135	Below -35 (-37) or above 120 (48)	
Coil Sensors		
Defrost Control	Coil Sensor Fault°F (°C)	Result
10M8901	Below -40 (-40) or above 140 (60)	If the <u>coil temperature sensor</u> is detected as being open, shorted or out of the temperature range of the sensor, the demand defrost control will not perform demand or time/temperature defrost operation. The demand defrost control will display the appropriate fault code. <u>Heating and cooling operation will be allowed in this fault conditions.</u>
60L3901		
46M8201		
56M8501		
100135	Below -35 (-37) or above 120 (48)	

**Table 10. Sensor Resistance
(Ambient and Coil Sensors)**

DEGREES F°	RESISTANCE
100	5743
97	6157
94	6578
92	7007
89	7444
86	7890
84	8343
82	8802
80	9277
78	9757
76	10247
74	10747
72	11256
70	11776
68	12306
66	13122
64	13681
62	14540
60	15129
58	16036
56	16973
54	17616
52	18607
50	19633
48	20695
46	22171
43	23720
39	26626
36	28868
34	30774
32	32273
30	34374
28	36600
26	38359
24	40833
22	43468
20	46281
18	48517
16	51686
14	55089
12	58754
10	61693
8	65895
6	70458
4	74147
2	79465
0	85302

SENSOR LOCATIONS

Heat pumps that used defrost controls 10M8901, 60L3901, 46M8201 or 56M8501 will require the use of the provided defrost sensor harness (101334-02). The following illustrations indicates the location of the ambient and coil sensors. On heat pump models that use 100135 the existing defrost sensor harness will be used.

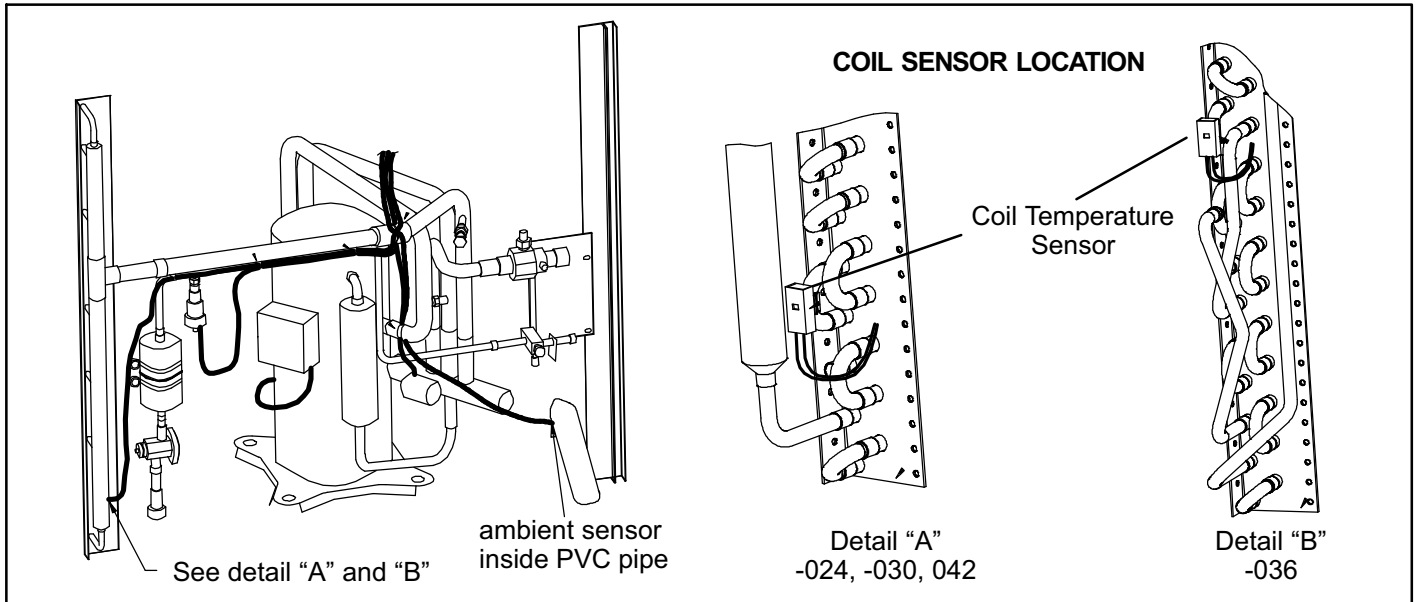

Figure 7. HP27 Ambient and Coil Sensor Locations

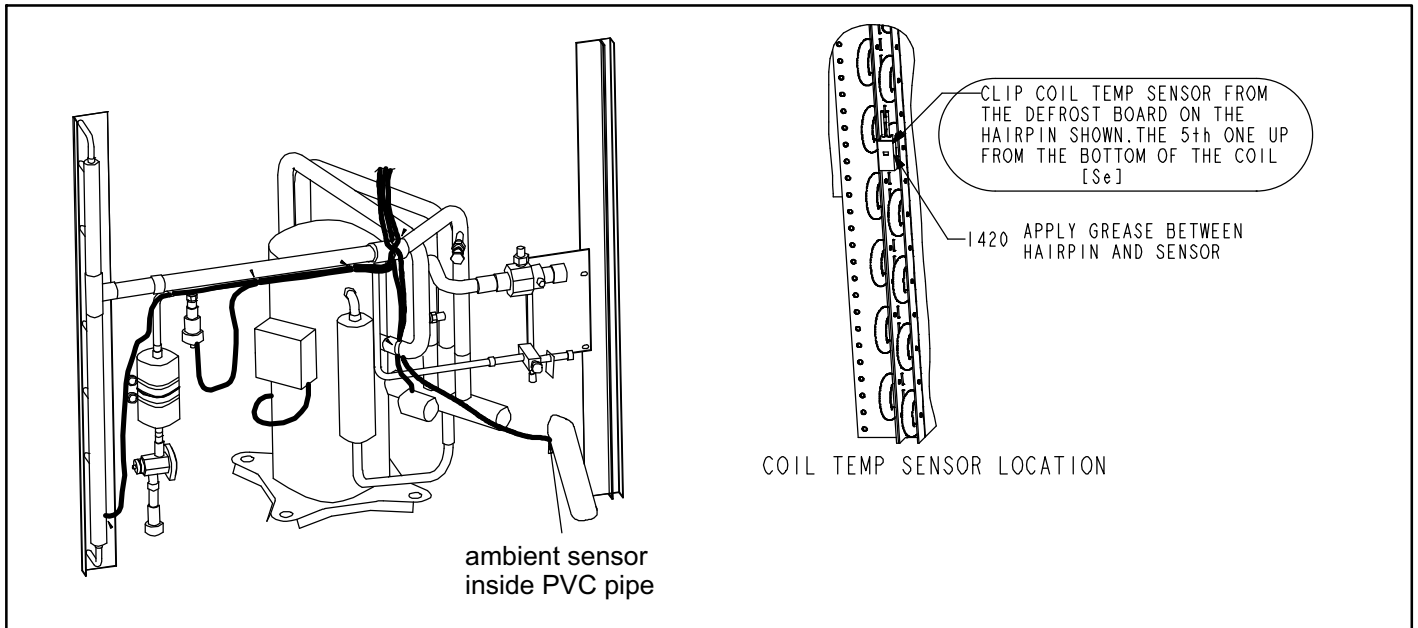

Figure 8. SPA Ambient and Coil Sensor Locations

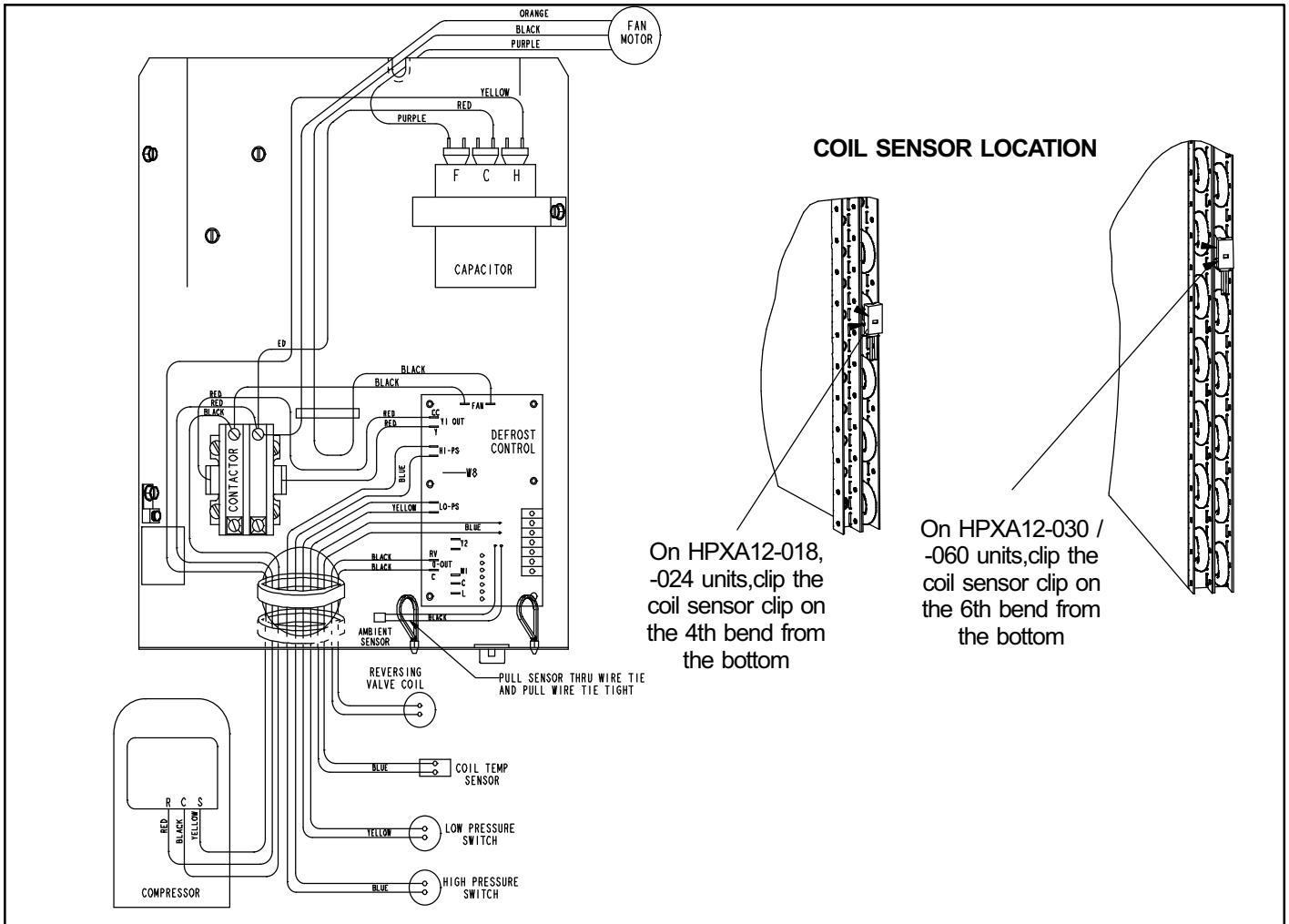

Figure 9. HPXA12 Ambient and Coil Sensor Locations

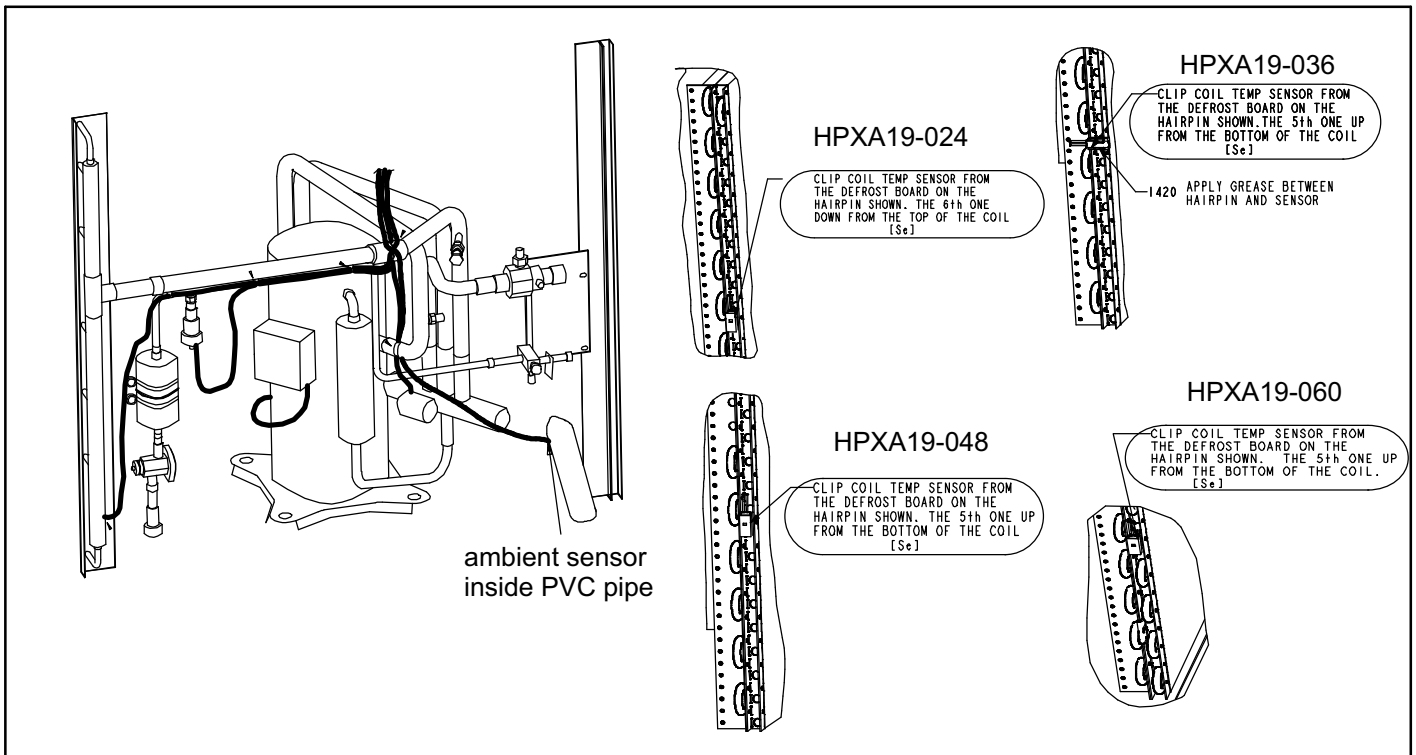

Figure 10. HPX19 Ambient and Coil Sensor Locations

Terminal Wiring

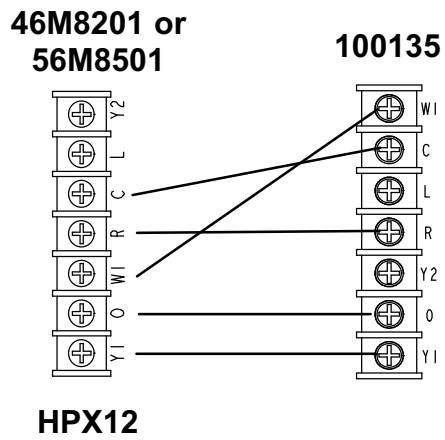
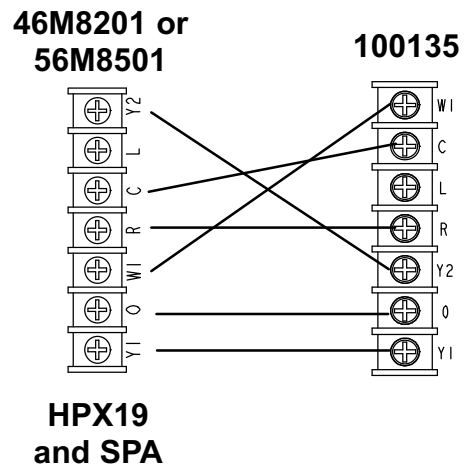
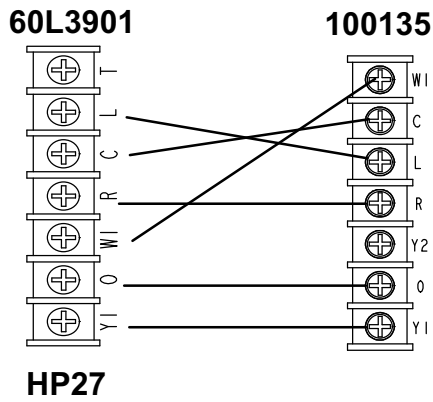
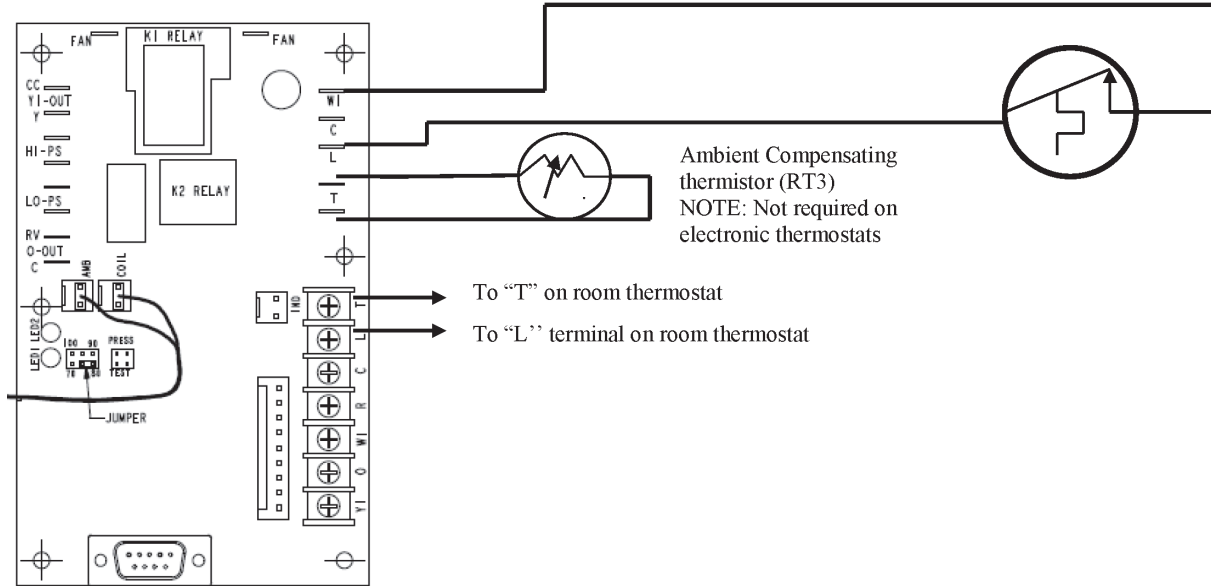

Figure 11. Terminal Match-ups to 100135 Defrost Control

Service Light Thermostat (S54) & Ambient Compensator Thermistor (RT3) Wiring to Defrost Boards

**Defrost Boards with W1, C, L, T & T spade connections
(10M8901 {shown}, 60L3901, 46M8201, 56M8501)**

Service Light Thermostat (S54)
(NOTE: Opens when sensor goes above 130°F)



**Replacement Defrost Board
(100135)**

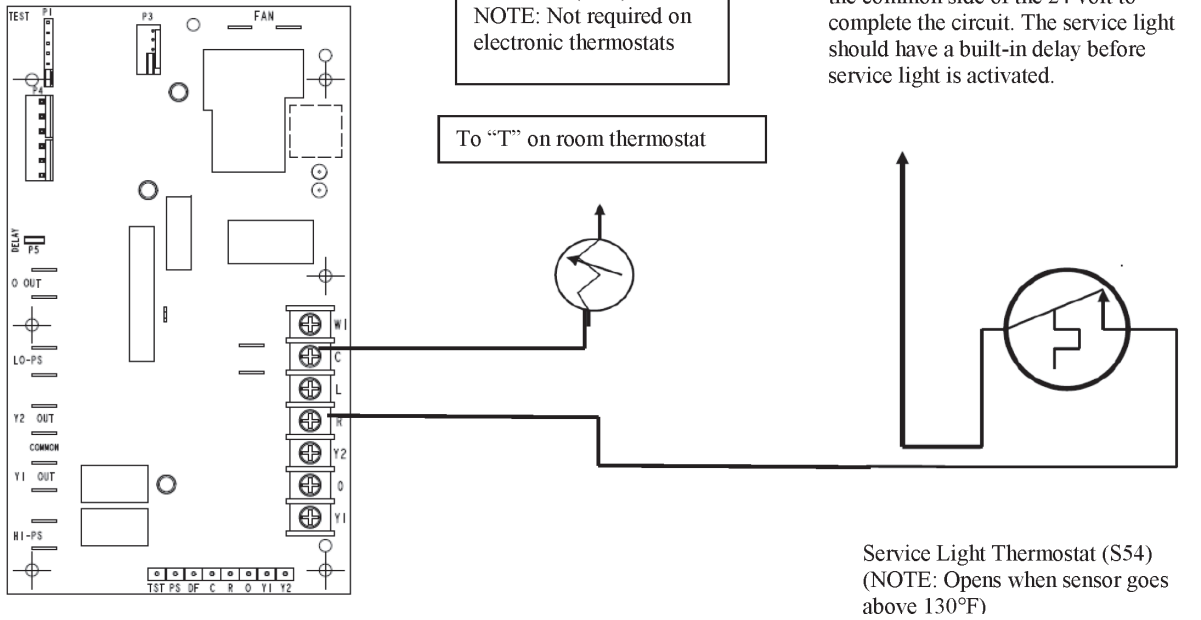

Figure 12. RT3 Sensor and Service Light Wiring