



©2016 Lennox Industries Inc.
Dallas, Texas, USA



This manual must be left with the owner for future reference.

⚠ WARNING

Improper installation, adjustment, alteration, service or maintenance can cause property damage, personal injury or loss of life.

Installation and service must be performed by a licensed professional HVAC installer (or equivalent) or service agency.

Specifications

Input voltage	5 VDC
Ambient temperature	23~110°F (-5~43°C)
Ambient humidity	RH40%~RH90%

INSTALLATION/ OPERATION INSTRUCTIONS

M0STAT64 Indoor Unit Programmable Controller

CONTROLS

507644-01

08/2016

⚠ IMPORTANT

Frequent changes to operating mode may cause system malfunction. Allow at least one minute between mode changes to allow the system to stabilize.

Shipping and Packing List

Package 1 of 1 contains;

- 1 – Wired Controller
- 1 – Lithium battery
- 3 – Screws (mount to wall)
- 2 – Screws (mount to J-box)
- 2 – Plastic spacers (J-box)
 - 1 – Connection Cable A with connector for all indoor units
 - 1 – Connection Cable B with connector for MMDA, MCFA, M22A and M33A indoor units
 - 1 – Connection Cable C with connector for MWMA indoor units
- 1 – Installation and operation manual

General

The M0STAT64Q is a wired programmable local controller for mini-split indoor units with convenient timed schedules for daily operation. These instructions are intended as a general guide and do not supersede local codes in any way. Consult authorities having jurisdiction before installation.

Requirements

Be sure that power supply has been turned off before beginning installation. This controller should be used only as described in this manual. Do not install the controller on outside walls (where there is unconditioned space on opposite side of wall) or in locations where direct sunlight may be present.

Dimensions

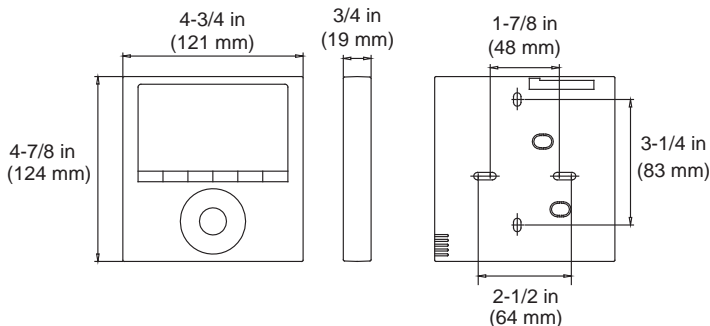

Figure 1. M0STAT64Q Dimensions

Wiring Connections

⚠ WARNING

Be sure that power supply has been turned off before beginning installation.

⚠ CAUTION

Clean controller using a clean, damp cloth. Do not spray cleanser on or around controller.

⚠ WARNING

Do not operate controller with wet hands.

⚠ CAUTION

Do not install controller in areas where heavy oil, vapor, or gases containing sulfur may exist or the controller may be damaged.

⚠ IMPORTANT

Read all of the information in this manual before using this controller. All wiring must conform to local and national building and electrical codes and ordinances. This is a 5 VDC controller. Do not install on voltages higher than 5 VDC.

- This manual provides the installation instructions for this controller. Refer to the included wiring diagrams to connect the controller to the indoor unit.
- The controller uses low voltage. Keep a minimum distance of 12" (305 mm) between low voltage control wire and high voltage power wires.

⚠ IMPORTANT

The provided cables must be used. Do not use excessive force while pulling the cable or when making the connections.

- Ground the shielded control wiring.
 - Do not use a megger to test insulation.
 - The controller cable length should not exceed 164 ft (50 m).
1. Use the wiring connections illustrations (Figures 2 and 6) to connect the controller to the indoor unit. **NOTE** - Connection details for wall-mounted units differ from the other indoor unit types.

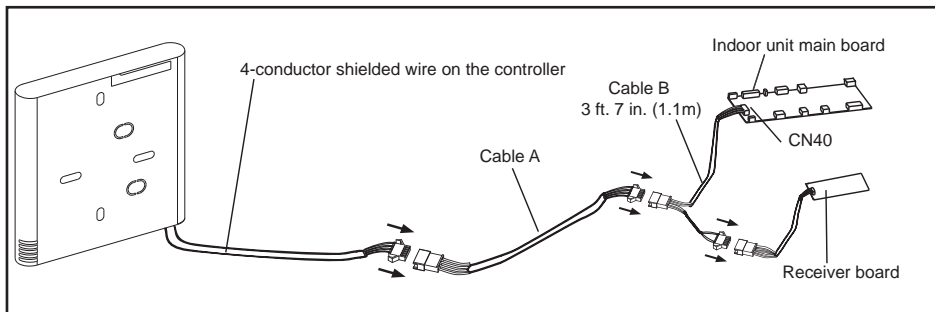

Figure 2. Wiring Connections MMDA, MCFA, M22A and M33A

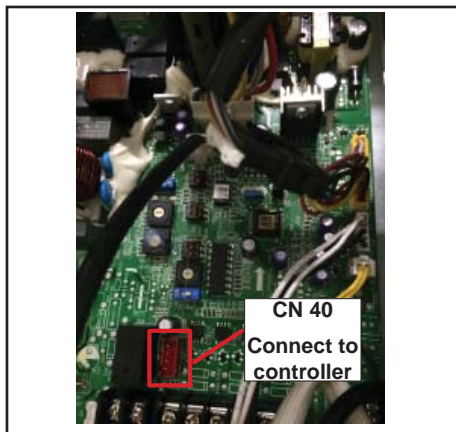

Figure 3. MMDA Main Board

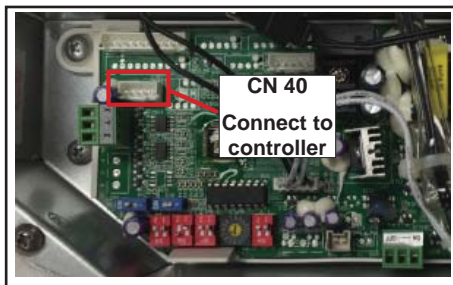

Figure 5. M22A and M33A Main Board

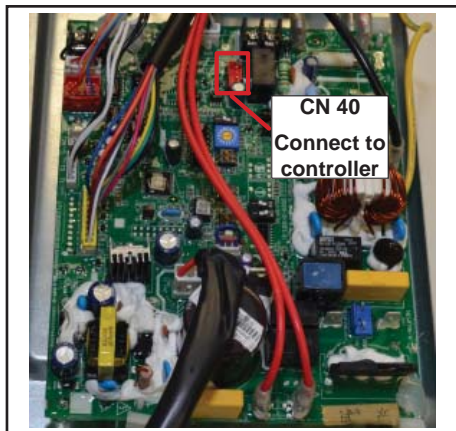

Figure 4. MCFA Main Board

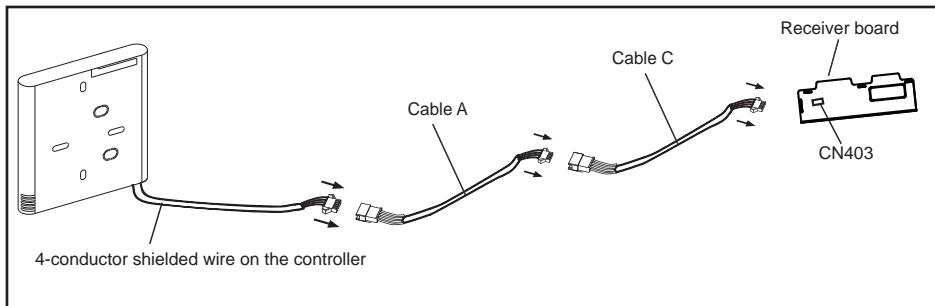

Figure 6. Wiring Connections MWMA

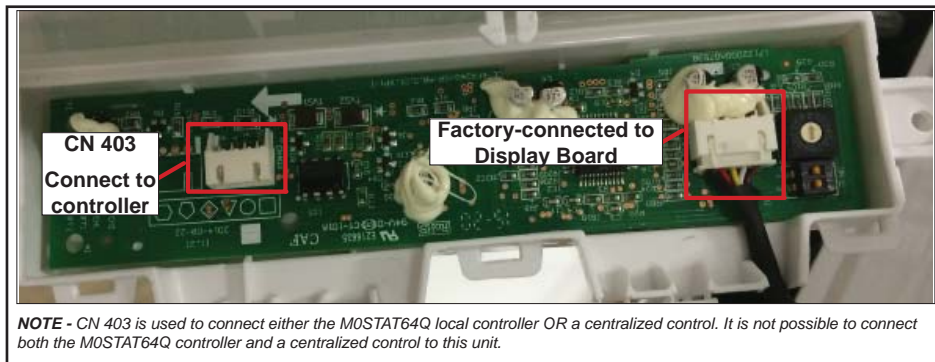

Figure 7. MWMA Receiver Board

2. Select the cable exit route from the back of the controller. See figure 8.

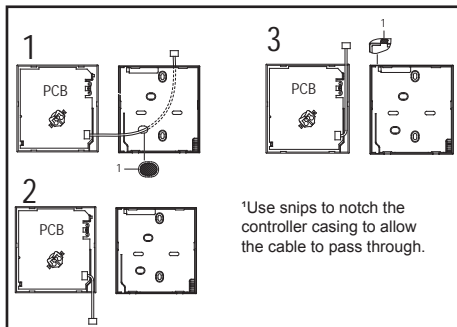

Figure 8. Select Cable Route

3. Include a drip loop in the cable. See figure 9.
4. Seal the cable entrance to the controller casing and any wall penetrations to prevent water from entering the controller. See figure 9.

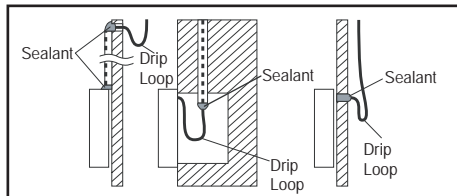

Figure 9. Prevent Water from Entering Controller Casing

5. Reattach the controller to the back plate. Be careful not to pinch or bind the wires. See figure 10.

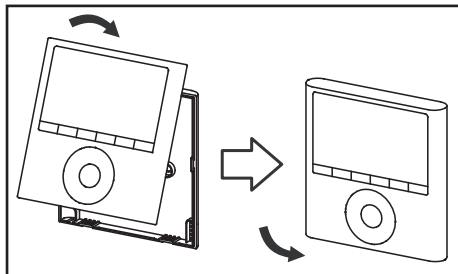

Figure 10. Reattach Controller to Back Plate

Installation

1. Remove the controller from the back plate using a flat-head screwdriver. See figure 11.

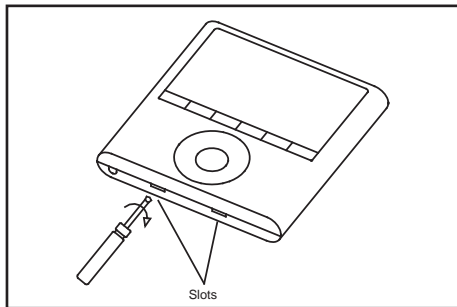

Figure 11. Remove Back Plate

2. Mount the back plate as appropriate for your application. See figures 12 and 13.

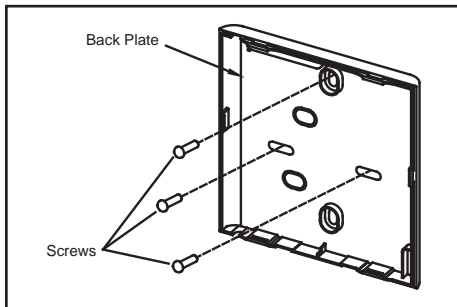

Figure 12. Attach Back Plate to Wall

3. J-box installation - Adjust the length of the two plastic spacers as needed to allow the controller to be mounted flush with the wall.

NOTE – Be sure to provide for future maintenance by allowing enough slack in the wiring to allow the controller to be removed from the wall if needed.

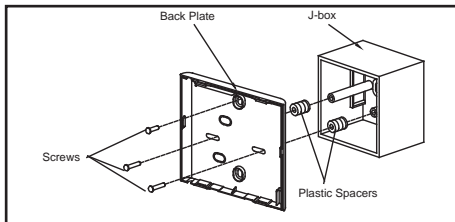
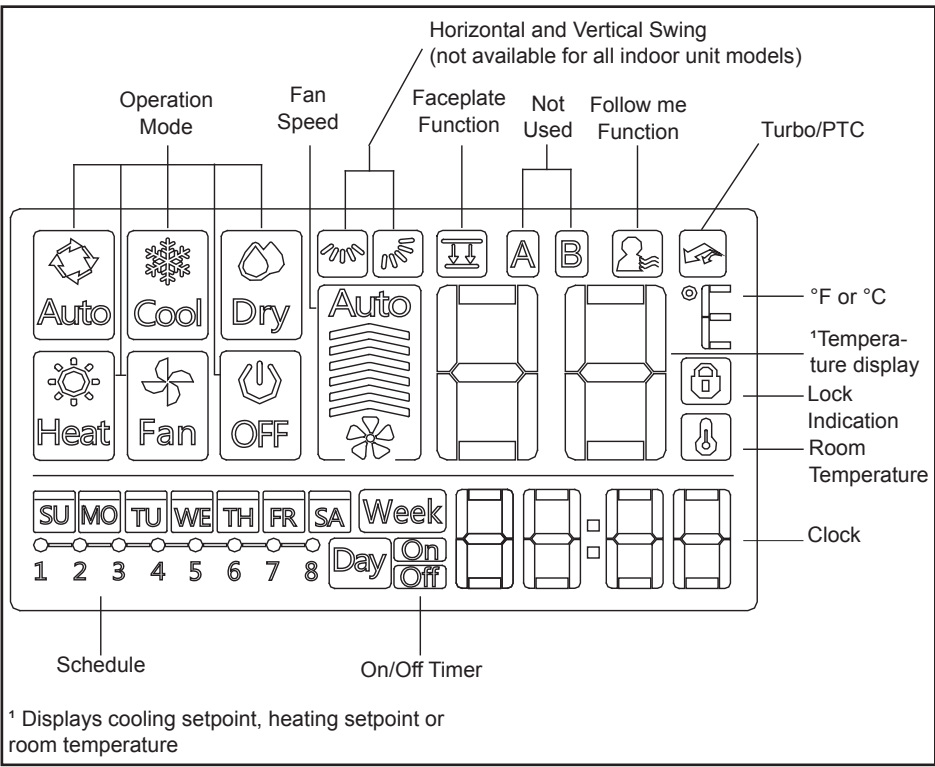

Figure 13. Attach Back Plate to J-box

4. Insert the provided battery into controller, positive side out. The battery stores the day and time in case of power outage. Replace the battery when its charge is depleted.
5. Reattach the controller to the back plate. Be careful not to pinch or bind the wires. See figure 10.

Display



Description of Buttons

Swing button (Swing function not available for all indoor unit models)

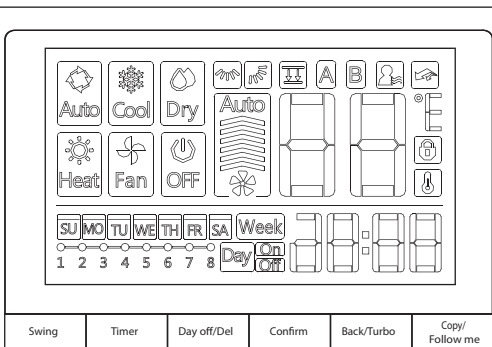

Timer
Day Off/
Delete

Decrease

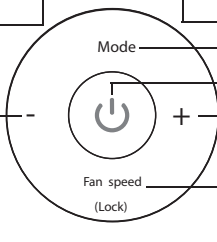

Mode

Fan speed
(Lock)

Copy/
Follow me
Back/Turbo
Confirm
Mode
Power
Increase
Fan speed
(Lock)

Setup

Set the Current Day and Time

1. Press and hold the Timer button for 3 seconds.
2. Use the + and - buttons to select the day. The selected day will flash.
3. Press the Timer button to complete the date setting.
4. Use the + and - buttons to set the current time.
NOTE – *the controller uses a 24-hour clock.*
5. Press the Timer button to complete the time setting.

Select Fahrenheit or Celsius for display

Press and hold the Back/Turbo button and the Copy/Follow me button simultaneously for 3 seconds to toggle between displaying degrees Fahrenheit or degrees Celsius.

To Set Room Temperature Sensor Location

Press the Copy/Follow me button to toggle between having the room temperature sensed by the indoor unit or by the controller. **NOTE** - *The Follow me indicator will display on the screen when the room temp is being sensed by the controller.*

Key Pad Tone (beep)

1. Press and hold the Swing button and the Timer button simultaneously for 3 seconds to turn off the key pad tone.
1. Press and hold the Swing button and the Timer button simultaneously for 3 seconds again to turn on the key pad tone.

Operation

To Start/Stop Operation

Press the Power button.

To set the operation mode

1. Press the Mode button to set the operation mode.
2. Use the + and - buttons to scroll through the mode selections.
 - **Auto** – System will automatically switch between heating and cooling depending on the temperature sensed.
 - **Cool** – System operates in cooling mode.
 - **Dry** – System removes humidity according to preset conditions (fan speed and setpoint temperature, not a humidistat sensor). Cannot adjust fan speed.
 - **Heat** – System operates in heating mode.
 - **Fan** – Fan only, no heating or cooling.

To Set (or change) the Setpoint

Press the + and - buttons to set the setpoint.

NOTE - the setpoint range is 62-86°F (17-30°C).

To Set the Fan Speed

Press the Fan speed (Lock) button to scroll through the fan speeds. Auto → Low → Med → High

To Set Child Lock Function

1. Press and hold the Fan speed (Lock) button for 3 seconds to lock all of the controller buttons.
2. Press and hold the Fan speed (Lock) button again for 3 seconds to unlock all of the buttons.

Turn ON/OFF Turbo Function

Press the Back/Turbo button to activate and deactivate the turbo functionality.

- **Cooling Mode** - Turbo sets the indoor unit fan speed to high for a factory-set period of time.

Set Swing Function

Press the Swing button to adjust louver direction and oscillation.

1. Press the Swing button to adjust the louver position. Each press moves the louvers 6°.
2. Press and hold the Swing button for two seconds to begin continuous louver oscillation. The Swing icon displays on the screen. Swing functionality not available for all indoor unit types.
3. For cassette units only, adjust each of the four louvers independently. Press and hold the Swing button for two seconds. The Swing icon will flash. Press the increase or decrease buttons to select the louver to adjust (the -0 setting makes all louvers move at the same time). After selecting the louver to adjust, press the Swing button to adjust the louver angle. Each press moves the louver 6°.

Timer and Schedules

Use the Timer button to setup Weekly schedules or to setup timed operation for the indoor unit. Timers are used to schedule On/Off operation only. Schedules are used to change operational settings for defined periods of time (events).

Setup Timed Operation Start Time

1. Press the Timer button until Day On is highlighted.
2. Press the Confirm button.
3. Use the + and - buttons to set the time to start operation.
4. Press the Confirm button.

Setup Timed Operation Stop Time

1. Press the Timer button until Day Off is highlighted.
2. Press the Confirm button.
3. Use the + and - buttons to set the time to stop operation.
4. Press the Confirm button.

Setup Timed Operation Start and Stop Time

1. Press the Timer button until Day On/Off is highlighted.
2. Press the Confirm button.
3. Use the + and - buttons to set the time to start operation.
4. Press the Confirm button
5. Use the + and - buttons to set the time to stop operation.
6. Press the Confirm button.

Create Schedules (up to 8 events per day)

1. Press the Timer button until Week is highlighted.
2. Press the Confirm button.
3. Use the + and - buttons to select the day of the week to setup the scheduled events.
4. Press the Confirm button.
5. Setup the first event of the schedule.

Create and Setup Scheduled Events (up to 8 events per day)

1. After selecting the scheduled day.
2. Use the + and - buttons to set the start time of the event. The display will show the event's start time, mode, setpoint and fan speed.
3. Press the Confirm button to confirm the start time and move to the operation mode selection.
4. Use the + and - buttons to select the operation mode for the event.
5. Press the Confirm button to confirm the operation mode and move to the setpoint selection.
6. Use the + and - buttons to set the setpoint for the event.
7. Press the Confirm button to confirm the setpoint and move to the fan speed selection. Not available when operation mode is set to Fan or Off.
8. Use the + and - buttons to select the fan speed for the event.
9. Press the Confirm button to confirm the fan speed and complete the settings for this event. Not available when operation mode is

set to Auto, Dry or Off.

10. Follow steps 2 through 9 to setup the next event. Each event ends at the start time of the next event.

NOTE - Use the Back/Turbo button to return to the previous step during event setup.

Activate and Deactivate Timed Operation

1. Press the Timer button to activate timed operation.
2. Press the Power button to deactivate timed operation.

Setup Days Off

Setup a day, or multiple days, within the scheduled week for which the indoor unit will not operate. When the day arrives, the unit will be powered off and will not operate until the next day's first event. Once the set day has passed, the Day Off setting is automatically removed.

1. Press the Timer button.
2. Press the Confirm button.
3. Use the + and - buttons to select the day of the week.
4. Press the Day off/Del button.
5. Press the Back/Turbo button.
6. Follow steps 3 and 4 for every day off required.

Copy a Schedule to a New Day

All events for the scheduled day will be copied.

1. Press the Timer button until Week is highlighted.
2. Press the Confirm button.
3. Use the + and - buttons to select the day to copy from.

4. Press the Copy/Follow Me button. The letters "CY" will be displayed on the screen.
5. Use the + and - buttons to select the day to copy to.
6. Press the Copy/Follow Me button to confirm.
7. Press the Back/Turbo button to return to the weekly timer.
8. Follow steps 3 through 7 to copy a schedule for additional days.

Edit a Scheduled Event

1. Press the Timer button until Week is highlighted.
2. Press the Confirm button.
3. Use the + and - buttons to select the day of the week.
4. Press the Confirm button.
5. Use the + and - buttons to select the event to edit. The display will show the event's start time, mode, setpoint and fan speed.
6. Use the + and - buttons to change the start time of the event.
7. Press the Confirm button to confirm the start time and move to the operation mode selection.
8. Use the + and - buttons to change the operation mode for the event.
9. Press the Confirm button to confirm the operation mode and move to the setpoint selection.
10. Use the + and - buttons to change the setpoint for the event.
11. Press the Confirm button to confirm the setpoint and move to the fan speed selection. Not available when operation mode is set to

Fan or Off.

12. Use the + and - buttons to change the fan speed for the event.
13. Press the Confirm button to confirm the fan speed and complete the changes for this event. Not available when operation mode is set to Auto, Dry or Off.

NOTE - Use the Back/Turbo button to return to the previous step.

Delete an Event from a Scheduled Day

This action cannot be undone.

1. Press the Timer button until Week is highlighted.
2. Press the Confirm button.
3. Use the + and - buttons to select the day of the week.
4. Press the Confirm button.
5. Use the + and - buttons to select the event to delete. The display will show the event's start time, mode, setpoint and fan speed.
6. Press the Day off/Del button.

Troubleshooting Fault Codes

Indoor Unit Display	M0STAT64Q Display	Error Code Description
N/A	F0	Communication error between wired controller and indoor unit
N/A	F1	The cassette faceplate is abnormal
E0	E7	Indoor unit EEPROM error
E1	E1	Communication error between indoor unit and outdoor units
E3	E8	Indoor fan speed error
E4	E2	Indoor Return air temperature sensor error
E5	E3	Indoor coil temperature sensor error
EC	EF	Low refrigerant
EE	EE	High water level alarm
F0	EA	Outdoor current overload sensed
F1	E5	Outdoor ambient temperature sensor error
F2	E5	Outdoor coil temperature sensor error
F3	E5	Compressor discharge temperature sensor error
F4	Ed	Outdoor unit EEPROM error
F5	Ed	Outdoor unit fan speed error
F6	E4	Indoor coil outlet temperature sensor error
P0	Eb	Inverter module IPM error
P1	N/A	High or Low voltage protection
P3	N/A	Outdoor unit low temperature lockout
P4	N/A	Compressor drive error
P6	N/A	High pressure/ low pressure switch open
P7	EF	Outdoor IGBT temperature sensor error

Indoor Unit Wiring Diagrams

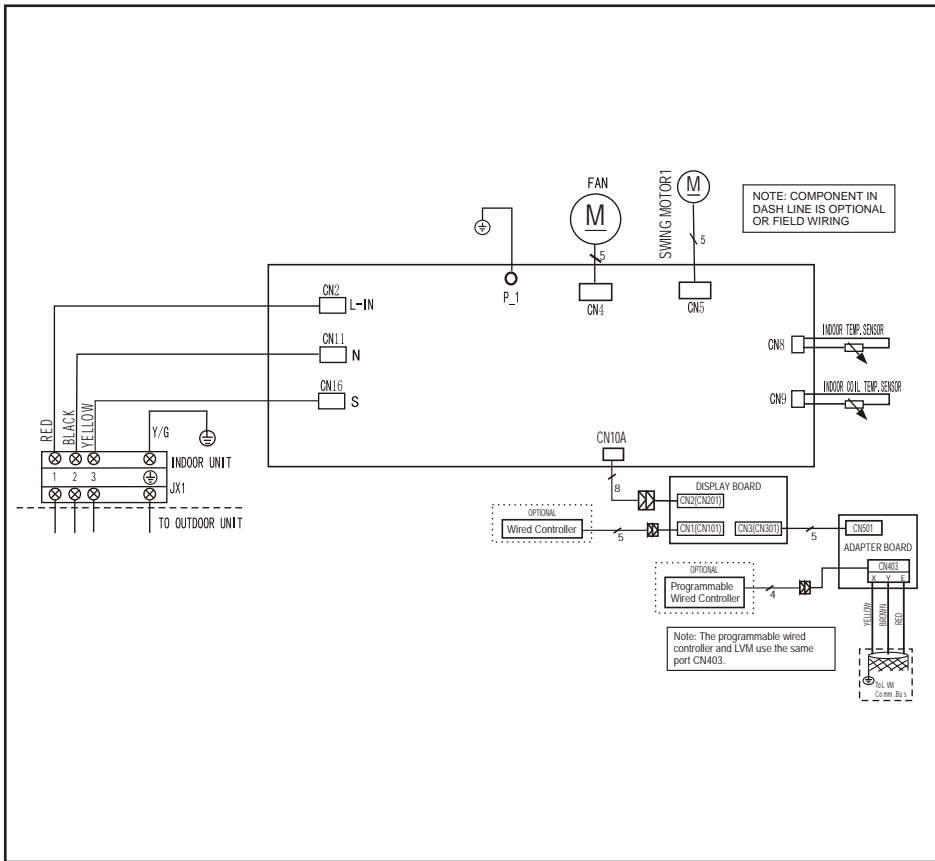

Figure 14. MWMA Unit Wiring Diagram

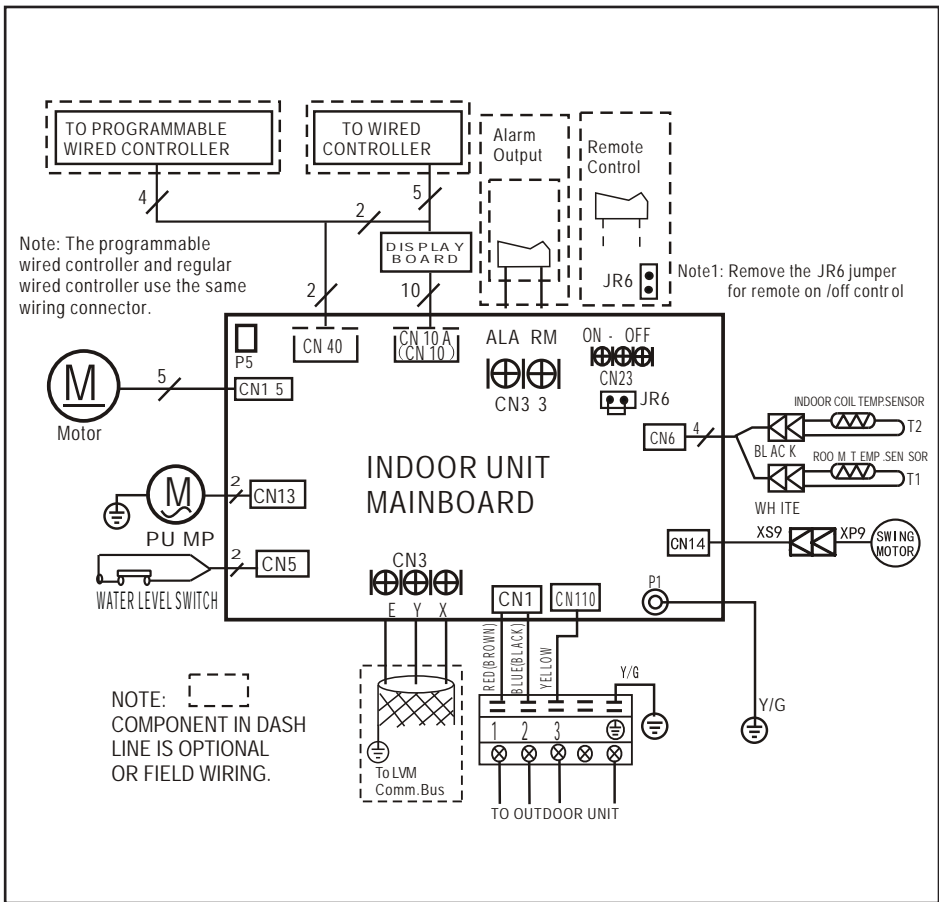

Figure 15. M22A009-018 and M33A024 Wiring Diagram

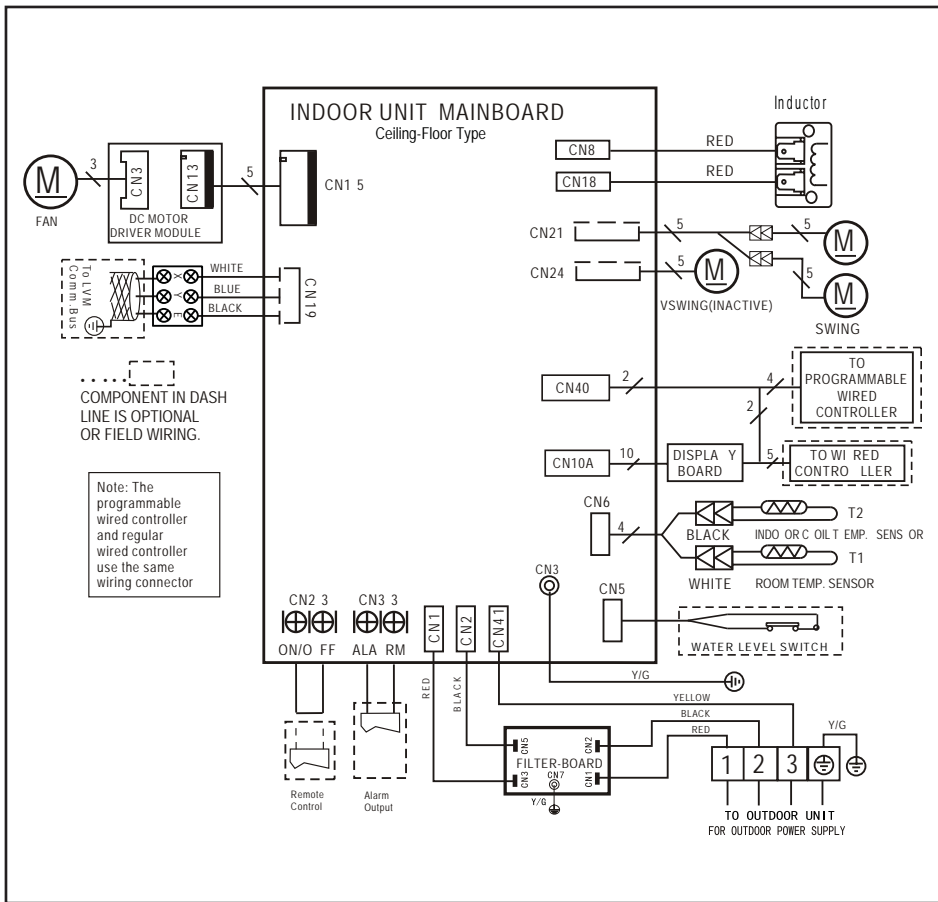

Figure 17. MCFA024 Wiring Diagram

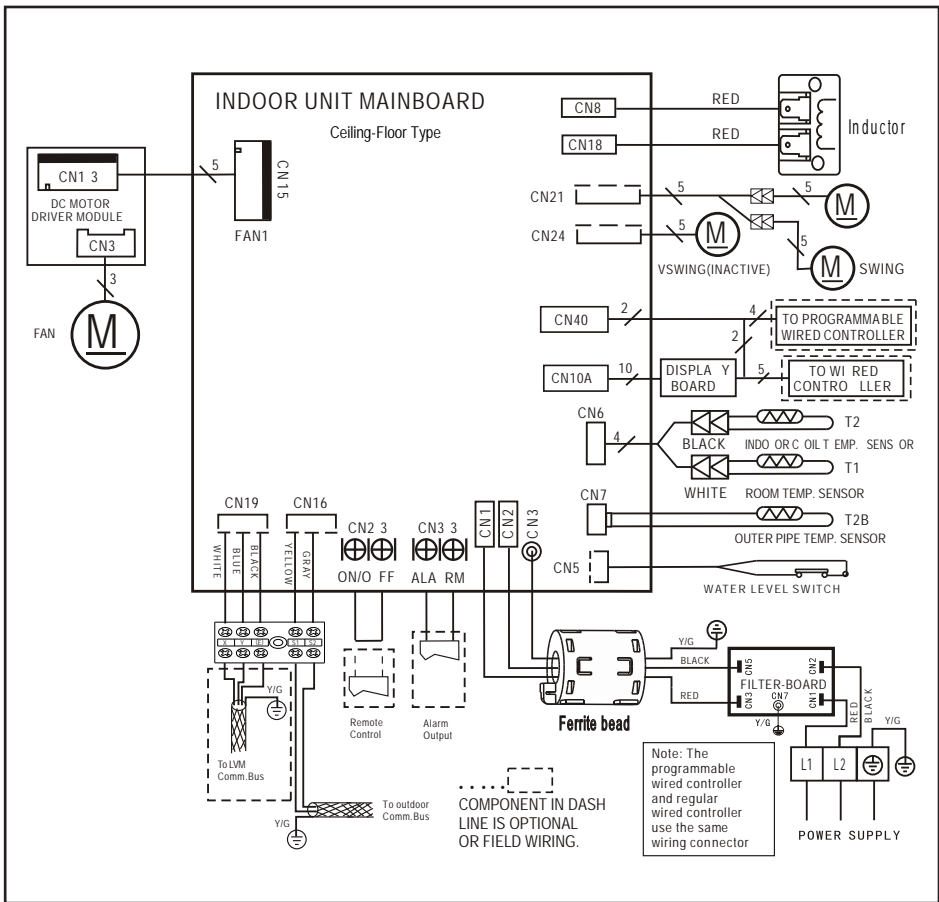

Figure 18. MCFA036 - 048 Wiring Diagram

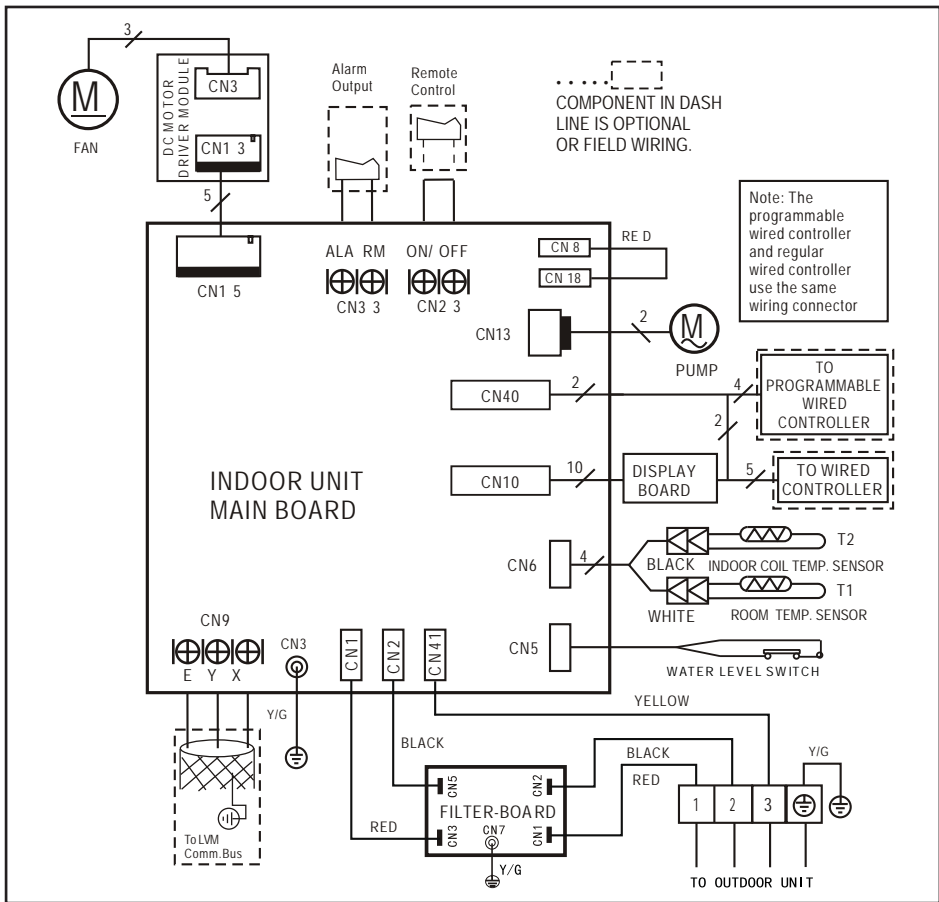

Figure 19. MMDA009 - 024 Wiring Diagram

