



©2021 Lennox Industries Inc.
Dallas, Texas, USA

COMMERCIAL SPLIT SYSTEM KITS AND ACCESSORIES

507753-02
2/2021

LOW AMBIENT KIT

INSTALLATION INSTRUCTIONS FOR LOW AMBIENT KIT (16F18) (618159-01) USED WITH ELS 072-090 SERIES UNITS

Shipping and Packing List

Package 1 of 1 contains:

- 1 – ICM Controller (A190 - see figure 5 for reference)
- 1 – Pressure transducer
- 1 – Fan power harness
- 1 – Valve depressor tees with two cores
- 2 – Wiring diagram sticker
- 1 – High pressure switch
- 1 – ICM Controller harness

Wire ties / Self-tapping screws

⚠ WARNING

Improper installation, adjustment, alteration, service or maintenance can cause property damage, personal injury or loss of life. Installation and service must be performed by a licensed professional HVAC installer or equivalent, service agency, or the gas supplier.

⚠ CAUTION

As with any mechanical equipment, contact with sharp sheet metal edges can result in personal injury. Take care while handling this equipment and wear gloves and protective clothing.

⚠ WARNING



Electric Shock Hazard! – Disconnect all power supplies before servicing.
Replace all parts and panels before operating.
Failure to do so can result in death or electrical shock.

Application

During low ambient conditions, the liquid line pressure will fall. If the pressure gets too low, the system will not have enough pressure drop across it to operate properly. To maintain the head pressure, the low ambient kit, instead of shutting down the condenser fan, slows down the condenser fan until the head pressure rises to the set point. This kit is designed for use in ambient temperatures no lower than 0°F (-17.8°C) unless otherwise noted in the Engineering Handbook.

Operation

Liquid line pressure for the ELS units is set at 315 psig. During low ambient conditions, as the liquid line pressure falls, the pressure transducer converts the liquid line pressure to an analog electric signal. The ICM controller then switches the fan motor to variable speed. The condenser fan speed is reduced, thus increasing the liquid line pressure to the set point to ensure unit keeps operating properly.

Hardware Installation

- 1 - Disconnect all power to the outdoor unit and open panels on outdoor unit to gain access to the control box.
- 2 - Install the ICM333 variable speed controller at the location shown below using self-tapping screws provided.

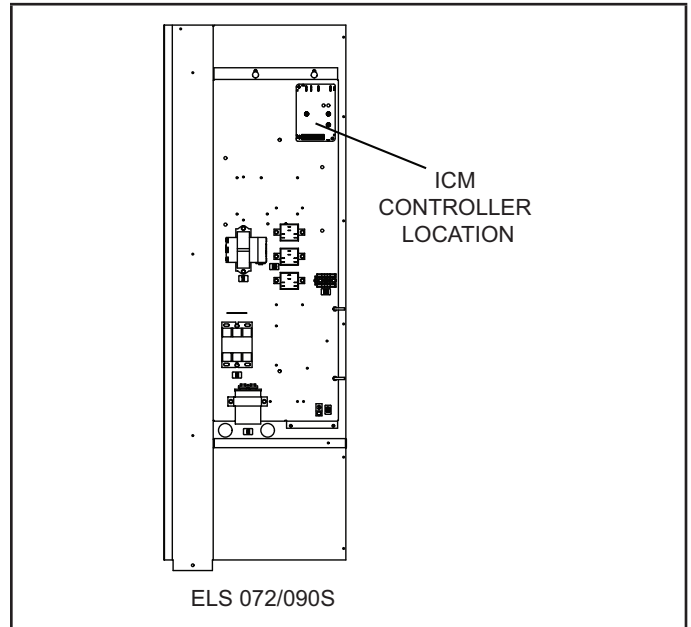

FIGURE 1. ICM Controller Location



507753-02

- 3 - Set the variable speed controller to the following settings:
 - Setpoint: 315 psig
 - Hard Start: Min.
 - Cut-out Speed: Set to 5th marker from minimum
 - Heat Pump Pin set to: N.O.
- 4 - Disconnect loss of charge switch from the liquid line.
- 5 - Install the valve depressor tees with two cores in place of the loss of charge switch.
- 6 - Connect the loss of charge switch to the valve core of the valve depressor tees.
- 7 - On units without loss of charge switch on the liquid line, install the transducer directly on the liquid line. Valve depressor tees not required.
- 8 - Install the pressure transducer (ICM380) to the valve core of the valve depressor tees on the liquid line. Refer to figure 2.
- 9 - Remove the existing high pressure switches from the compressor discharge line and replace them with the switches provided in the kit.

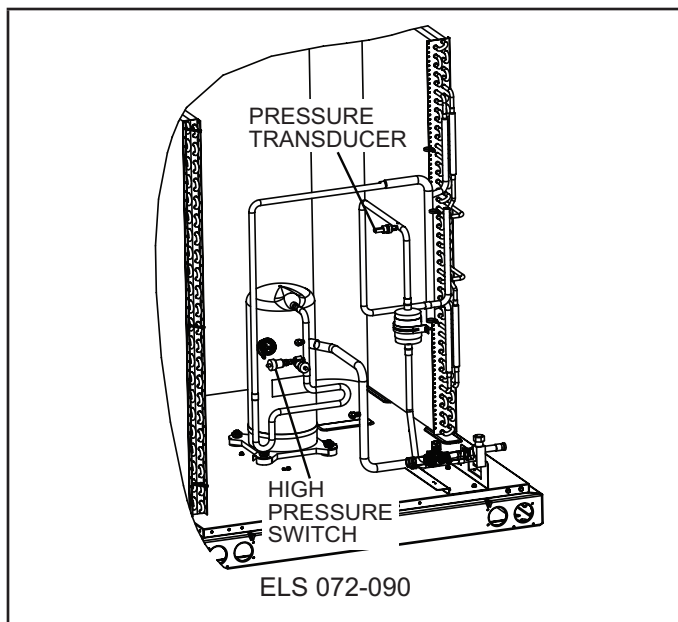

FIGURE 2. Pressure Transducer / Pressure Switch Location

Electrical Installation

Connections for ICM333

- 1 - Connect the line power L2 wire to the terminal marked Line 2 on the ICM333 controller.
- 2 - Connect the motors for the outdoor fan to the terminal marked Motor 2 (blue wire marked A190-M) on the ICM 333 controller (A190).
- 3 - Check the voltage to the unit. Depending on the voltage, connect Line Power L1 to the correct terminal marked by Line1/ Motor 1.
- 4 - For voltages between 120 - 277, connect the L1 to the terminal second from the left. For voltages between 480 – 600, connect L1 to the left most terminal on the ICM333 controller.

Connections for Pressure Transducer

- 1 - Connect the black wire from the pressure transducer to P1 BLK COMM on the controller.
- 2 - Connect the red wire from the pressure transducer to P1 RED on controller.
- 3 - Connect the green wire from the pressure transducer to P1 B, W, G on the controller.

⚠ IMPORTANT

It is essential that the existing fan power harness be removed and discarded as outlined in step 4 below. Continue to make the remaining connections per step 5.

Remaining Connections

- 1 - Install 24V Power Harness, A190 Controller (ICM 333) – A190-24V and A190-COM, to TB14-R and TB14-C.
- 2 - Remove wiring to K10 relay.
- 3 - Remove the wiring plugged into K10-4. DO NOT discard the wiring.
- 4 - Remove existing fan power harness and discard it. (Refer to figure 4 for the harness to be discarded.)
- 5 - After disconnecting factory wiring to K10-4 (blue female 1/4" QC terminal) per step 3, connect the wire marked K10-4/A190-M from the harness in the kit (blue male 1/4" QC) to the K10-4 wire that was unplugged (blue female 1/4" QC terminal). Plug wire from harness in kit marked A190-L2/K10- 4 into relay K10-4. Install remaining connections of the harness provided per the wiring diagram.
- 6 - Make sure all connections are in place.
- 7 - Use wire ties to bundle wiring and keep it away from sharp edges.
- 8 - Place the new wiring diagram sticker provided in kit on the unit.
- 9 - Restore power to outdoor unit.

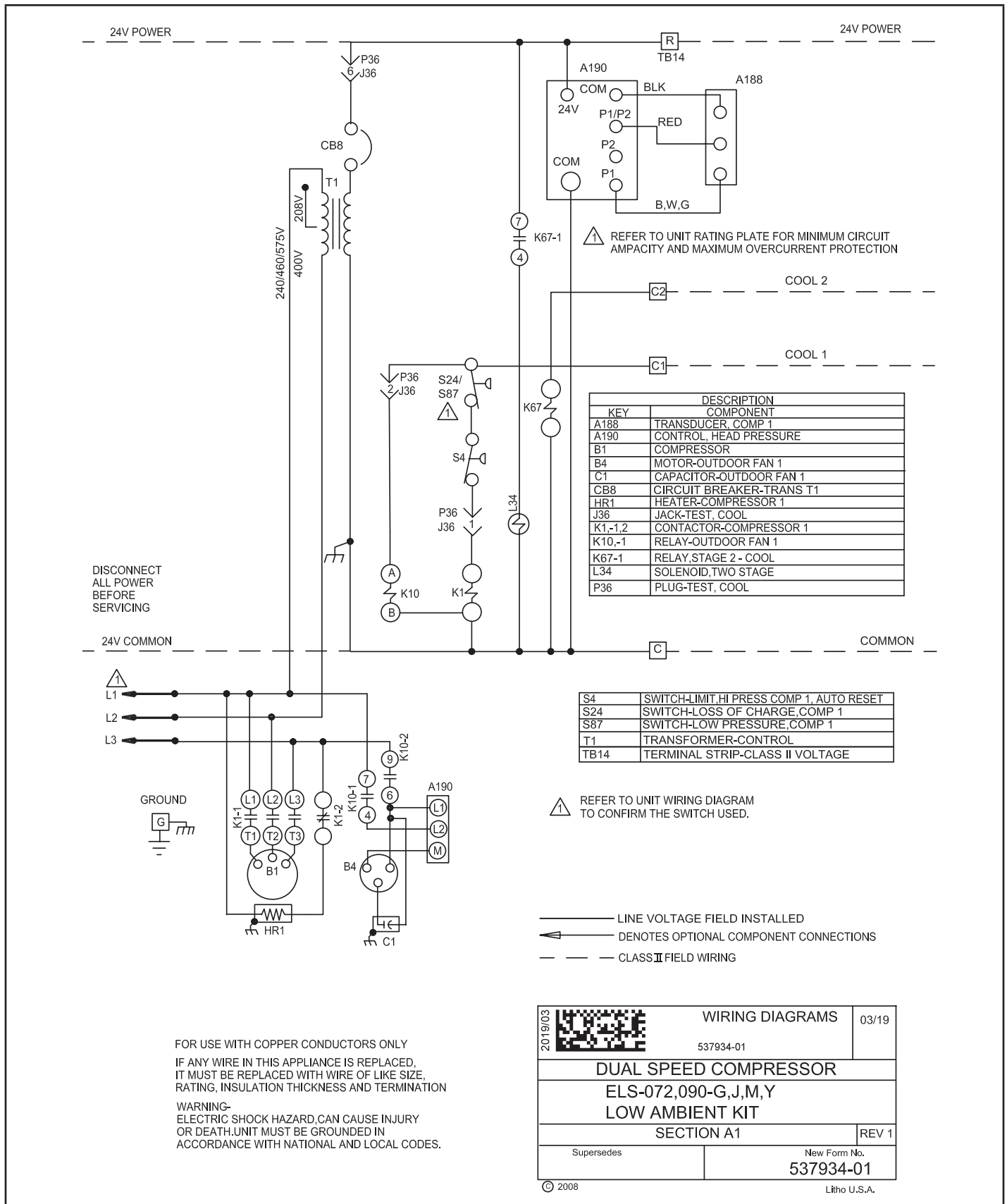

FIGURE 3. Wiring Diagram – ELS 072-090

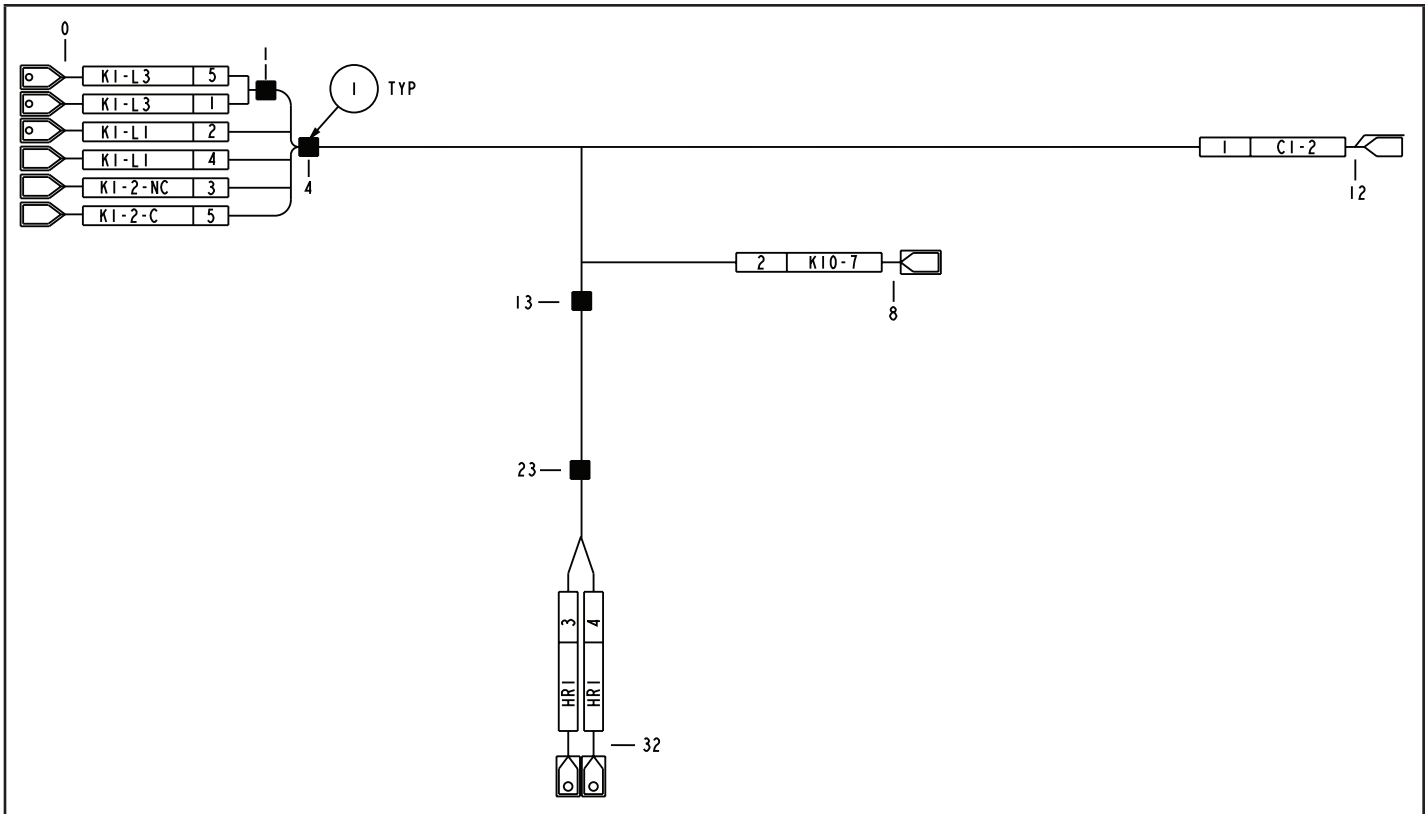

FIGURE 4. Factory-Installed Fan Power Harness (Must be Removed)



FIGURE 5. ICM Controller (A190)