

GAS KITS AND ACCESSORIES

507782-01
09/2017
Supersedes 65336701

GAS CHANGEOVER KIT

INSTALLATION INSTRUCTIONS FOR NATURAL TO REGULATED LP/PROPANE GAS CHANGEOVER KIT LB-115314E (82M94) USED WITH 100,000, 125,000, 150,000 AND 250,000 Btu/h UNIT HEATERS

⚠ WARNING

WARNING - This conversion kit is to be installed by a qualified service technician or other qualified agency in accordance with the manufacturer's instructions, all codes and requirements of the authority having jurisdiction in the USA or Canada. If the information in these instructions is not followed exactly, a fire or explosion may result causing property damage, personal injury or loss of life. The qualified agency performing this work assumes responsibility for this conversion.

Shipping and Packing List

Package 1 of 1 contains:

- 10 - Tapered burner orifices size #53 0.0595" (1.511mm) 1/8" NPT
- 1 - White Rodgers pressure measuring adapter kit 69M1701
- 1 - Honeywell VR8205 series gas valve conversion kit 48G2201
- 1 - White Rodgers 36 series gas valve conversion kit 28G6101
- 1 - LP kit label (580051-02)
- 1 - Unit conversion sticker (65296600)

Application

This natural to regulated LP/propane gas changeover kit is for use on FOAN-100, -125, 150, 250 and TU-A100S, 125S, 150S and 250S separated combustion unit heaters equipped with the Honeywell VR8205 or VR8305 standard opening gas valves and White Rodgers 36 series gas valves.

Installation

- 1 - Set thermostat to lowest setting. The gas supply must be shut off prior to disconnecting the electrical power and proceeding with the conversion.
- 2 - Turn automatic gas valve to **OFF** position.
- 3 - Disconnect gas supply from gas valve. Disconnect wiring at gas valve. Remove manifold/gas valve assembly (use 5/16" driver to remove four mounting screws which secure the manifold/gas valve assembly).
- 4 - Remove existing burner orifices. Apply pipe thread compound to threads of orifices provided in kit. Install orifices in manifold. See figure 1.

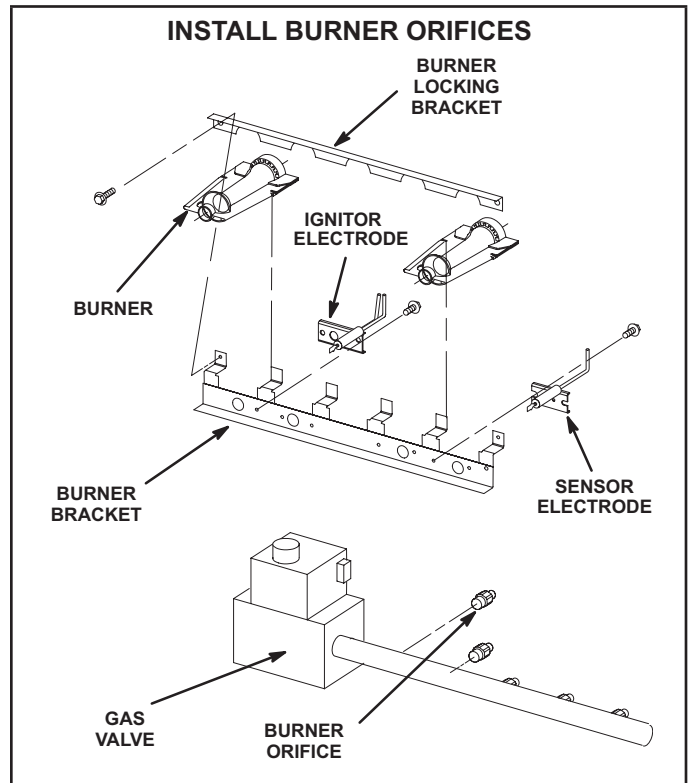

Figure 1

IMPORTANT - Do not allow pipe thread compound to enter orifice bore.

- 5 - Install gas valve conversion kit. Refer to manufacturer's instruction packed in valve conversion kit. See figures 2 and 3.

IMPORTANT - Make sure the correct conversion kit is used for the gas valve. Use **ONLY** White Rodgers conversion kit for White Rodgers gas valve and specific Honeywell conversion kit for specific Honeywell gas valve **ONLY**.

IMPORTANT - Install gas valve changeover sticker provided in valve conversion kit to visible area of gas valve.

- 6 - Reinstall manifold/valve assembly. Secure with four #10-16 X 5/8" HWHSMS screws.
- 7 - Connect gas supply to gas valve. Connect wiring to gas valve.
- 8 - Restore gas to unit.
- 9 - Affix unit conversion sticker (provided) next to unit rating plate.

IMPORTANT - Carefully check all piping connections. **DO NOT** use matches, candles, open flame, or other means of ignition to check for gas leaks. Use a soap solution or other preferred means.

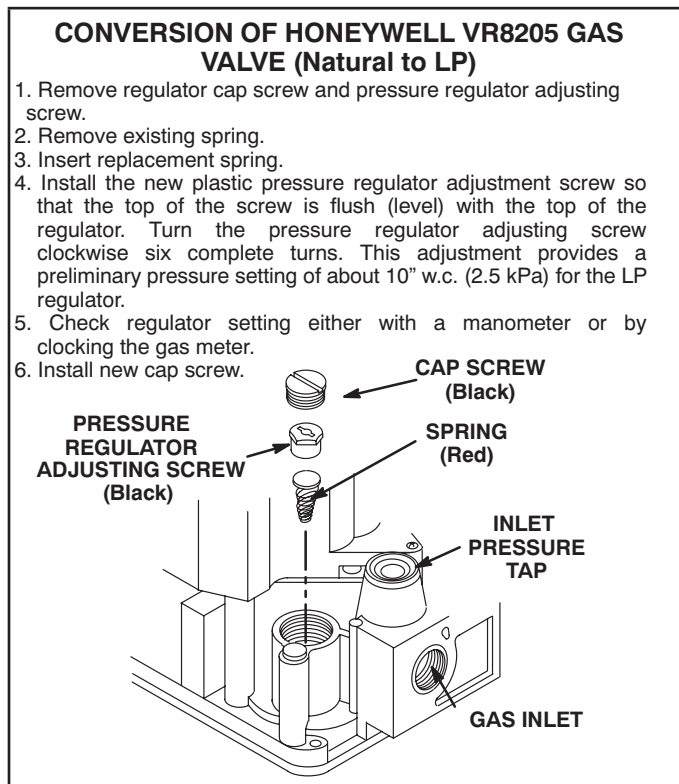

Figure 2

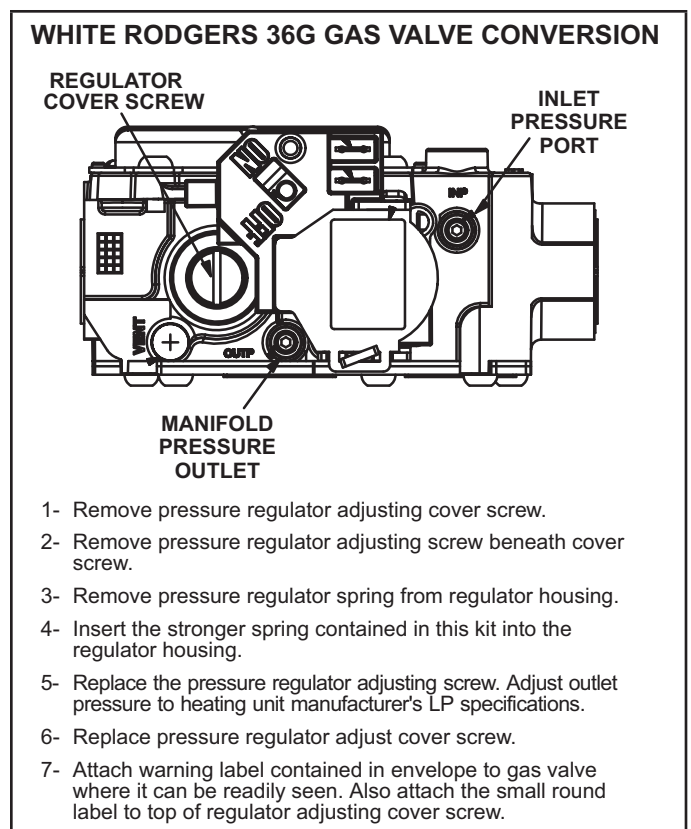

Figure 3

CAUTION

Some soaps used for leak detection are corrosive to certain metals. Carefully rinse piping thoroughly after leak test has been completed. Do not use matches, candles, flame or other sources of ignition to check for gas leaks.

Start-Up and Adjustment

BEFORE LIGHTING, smell all around the appliance area for gas. Be sure to smell next to the floor because some gas is heavier than air and will settle on the floor.

Use only your hand to push in or turn the gas control knob. Never use tools. If the knob will not push in or turn by hand, do not try to repair it, call a qualified service technician. Force or attempted repair may result in a fire or explosion.

A - Placing Unit In Operation:

IMPORTANT - Follow the lighting instructions provided on the unit. If lighting instructions are not available, see section below.

Separated combustion unit heaters are equipped with an automatic spark ignition system. DO NOT attempt to manually light burners on these unit heaters. Each time thermostat calls for heat, the burners will automatically be lit.

- 1 - Make sure thermostat is set below room temperature and power is turned off to unit.
- 2 - This appliance is equipped with an ignition device which automatically lights the burners. DO NOT try

to light the burners by hand.

- 3 - Turn gas valve to **OFF**. Do not force. For Honeywell valves, turn knob clockwise to **OFF**. For White Rodgers valves, move the lever to **OFF**.
- 4 - Wait 15 minutes to clear out any gas. If you then smell gas, immediately call your gas supplier from an outside phone. Follow the gas supplier's instructions. If you do not smell gas go to next step.
- 5 - Turn gas valve to **ON**. Do not force. For Honeywell gas valves, turn the knob 90° counterclockwise to **ON**. For White Rodgers valves, move the lever to **ON**.
- 6 - Turn on all electrical power to unit.
- 7 - Close unit door.
- 8 - Set thermostat to desired setting.

NOTE - When unit is initially started, steps 1 through 8 may need to be repeated to purge air from gas line.

B - Gas Pressure Adjustment

- 1 - Check gas line supply pressure with unit firing at maximum rate. A minimum of 10.4" w.c. should be maintained.
- 2 - After gas line pressure has been checked and adjusted, check manifold pressure at the pressure tap on the outlet side of the gas valve. The correct manifold pressure for LP/propane gas is given in table 1. Refer to figures 2 and 3 for gas manifold pressure adjustment screw location.

TABLE 1

GAS MANIFOLD PRESSURES (PROPANE)			
UNIT MODEL #	UNIT INPUT RATE (Btuh) MODEL	ALTITUDE (FT)*	
		0-2000 FT.	2000-4500 FT in CANADA ONLY**
FOAN-100	100,000	9.5" w.c.	9.5 w.c.
FOAN-125	125,000	9.5" w.c.	9.5 w.c.
FOAN-150	150,000	9.5" w.c.	9.5" w.c.
FOAN-240	250,000	9.0" w.c.	9.0" w.c.

**In the USA, for elevations above 2,000 ft., the unit heater shall be derated 4% for each 1000 ft. elevation.

C - Burner

Start burner and allow to operate for a few minutes. Observe flame. Flame should be predominantly blue (with some yellow), strong and steady. Flame should burn continuously from all burners.

D - Means To Verify Gas Rate

Input must not exceed amount shown on unit rating plate. In cases where gas is not metered, the service technician performing the conversion will need to supply the meter. Input may then be checked by the following method:

The utility company or LP/propane gas distributor may be contacted for the heating value of the gas. All other appliances should be shut off during the input check.

Locate meter just upstream in regulated pressure (10.4" w.c. to 13.0"w.c.). To check the Btu input rate, the dial hand on the gas meter should be timed for at least one revolution, using the one cubic foot dial. To assure accurate measurements, use temperature and pressure correction factors for the meter.

To determine the number of seconds required for the flow of one cubic foot of gas, use the following formula:

$\frac{(\text{BTUH CONTENT})}{\text{HEATING VALUE OF GAS X 3600}}$
UNIT BTUH INPUT
<p>Example: 1000 BTU gas Unit input 200,000 BTUH</p> <p>Seconds for one cubic foot =</p> $\frac{1000 \times 3600}{200,000} = 18 \text{ seconds}$

E - Ignition System

Check the normal operation sequence of the ignition system after conversion. See instruction manual supplied with the unit.