

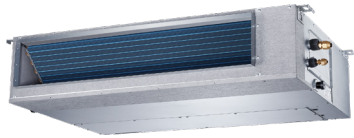

©2020 Lennox Industries Inc.  
Dallas, Texas, USA



# INSTALLATION INSTRUCTIONS

## MMDB Medium-Static Ducted Indoor Series matched with MLA/MLB/MPB Heat Pump Outdoor Series

SINGLE-ZONE MINI-SPLIT SYSTEMS  
(208/230V)  
507783-02 6/2020  
Supersedes 507783-01

### Table of Contents

<b>General</b> .....	<b>1</b>
<b>Included Parts</b> .....	<b>2</b>
<b>Indoor / Outdoor Unit Match-Ups</b> .....	<b>2</b>
<b>Model Number Identification</b> .....	<b>3</b>
<b>Typical System Components</b> .....	<b>4</b>
<b>System Dimensions</b> .....	<b>5</b>
<i>Outdoor Units</i> .....	<b>5</b>
<i>MMDB Indoor Units</i> .....	<b>7</b>
<b>System Clearances</b> .....	<b>8</b>
<i>Outdoor Unit</i> .....	<b>8</b>
<i>Indoor Unit</i> .....	<b>8</b>
<b>Torque Requirements for Caps and Fasteners</b> .....	<b>8</b>
<b>Indoor Unit Installation</b> .....	<b>9</b>
<i>Unit Placement Considerations</i> .....	<b>9</b>
<i>Installation</i> .....	<b>9</b>
<i>Installation Guidelines</i> .....	<b>10</b>
<i>Field-Relocation of Return Air Filter</i> .....	<b>10</b>
<i>Indoor Unit Condensate Piping Connections</i> .....	<b>10</b>
<b>Outdoor Unit Installation</b> .....	<b>11</b>
<i>Placement Considerations</i> .....	<b>11</b>
<i>Direct Sunlight, Rain, Snow and Ice Protection</i> .....	<b>12</b>
<i>Prevailing Winds</i> .....	<b>13</b>
<i>Buried Refrigerant Pipe Protection</i> .....	<b>13</b>
<i>Condensate Piping</i> .....	<b>14</b>
<i>Securing the Outdoor Unit</i> .....	<b>14</b>
<b>Refrigerant Piping Connections</b> .....	<b>14</b>
<b>Leak Test and Evacuation</b> .....	<b>17</b>
<i>Leak Test</i> .....	<b>17</b>
<i>Triple Evacuation Procedure</i> .....	<b>17</b>
<b>Wiring Connections</b> .....	<b>17</b>
<i>Outdoor Unit</i> .....	<b>17</b>
<i>Indoor Unit</i> .....	<b>17</b>
<b>Unit Start-Up</b> .....	<b>23</b>
<b>Adding Refrigerant for Longer Line Set</b> .....	<b>23</b>
<b>Setting Airflow Rate</b> .....	<b>23</b>
<b>Troubleshooting</b> .....	<b>23</b>
<b>Test Run</b> .....	<b>24</b>
<i>Pre-Checks</i> .....	<b>24</b>
<i>Procedure</i> .....	<b>24</b>
<b>Dry Mode Operation (Dehumidification)</b> .....	<b>24</b>
<i>Procedure</i> .....	<b>24</b>
<i>Sequence of Operation</i> .....	<b>24</b>

**THIS MANUAL MUST BE LEFT WITH THE OWNER FOR FUTURE REFERENCE**

### **! WARNING**

Improper installation, adjustment, alteration, service or maintenance can cause property damage, personal injury or loss of life.

Installation and service must be performed by a licensed professional HVAC installer (or equivalent) or a service agency.

### **! WARNING**

The clean Air Act of 1990 bans the intentional venting of refrigerant (CFCs, HCFCs, and HFCs) as of July, 1992. Approved methods of recovery, recycling or reclaiming must be followed. Fines and/or incarceration may be levied for non-compliance.

### **! CAUTION**

As with any mechanical equipment, contact with sharp sheet metal edges can result in personal injury. Take care while handling this equipment and wear gloves and protective clothing.

#### **General**

Refer to the Product Specifications bulletin (EHB) for more product information. These instructions are intended as a general guide and do not supersede local or national codes in any way. Authorities having jurisdiction should be consulted before installation.



The MMDB Medium-Static Ducted indoor units are matched with an outdoor heat pump unit to create a mini-split system that uses HFC-410A refrigerant.

## Included Parts



Package 1 of 1 contains the following:

1 - Assembled Indoor Unit

The assembled indoor unit will include the following items:

Parts	Figure	Quantity	Parts	Figure	Quantity
M0STAT61Q-1 Wired controller		1	Installation Instruction and wired controller user guide.		1 ea.
Wired controller extension cable 6 ft (2m)		1			

1 - Assembled Outdoor Unit and the following items:

Parts	Figure	Quantity	Parts	Figure	Quantity
Drain connector		1	Seal ring		1

## Indoor / Outdoor Unit Match-Ups

Outdoor Unit	Indoor Unit	Voltage
MPB009S4S-*P	MMDB009S4-*P	208/230V
MPB012S4S-*P	MMDB012S4-*P	208/230V
MPB018S4S-*P	MMDB018S4-*P	208/230V
MPB024S4S-*P	MMDB024S4-*P	208/230V
MPB036S4S-*P	MMDB036S4-*P	208/230V
MPB048S4S-*P	MMDB048S4-*P	208/230V
MLA009S4S-*P	MMDB009S4-*P	208/230V
MLA012S4S-*P	MMDB012S4-*P	208/230V
MLA018S4S-*P	MMDB018S4-*P	208/230V
MLA024S4S-*P	MMDB024S4-*P	208/230V
MLB036S4S-*P	MMDB036S4-2P	208/230V
MLB048S4S-*P	MMDB048S4-2P	208/230V

# Model Number Identification

## OUTDOOR SINGLE ZONE HEAT PUMP UNITS

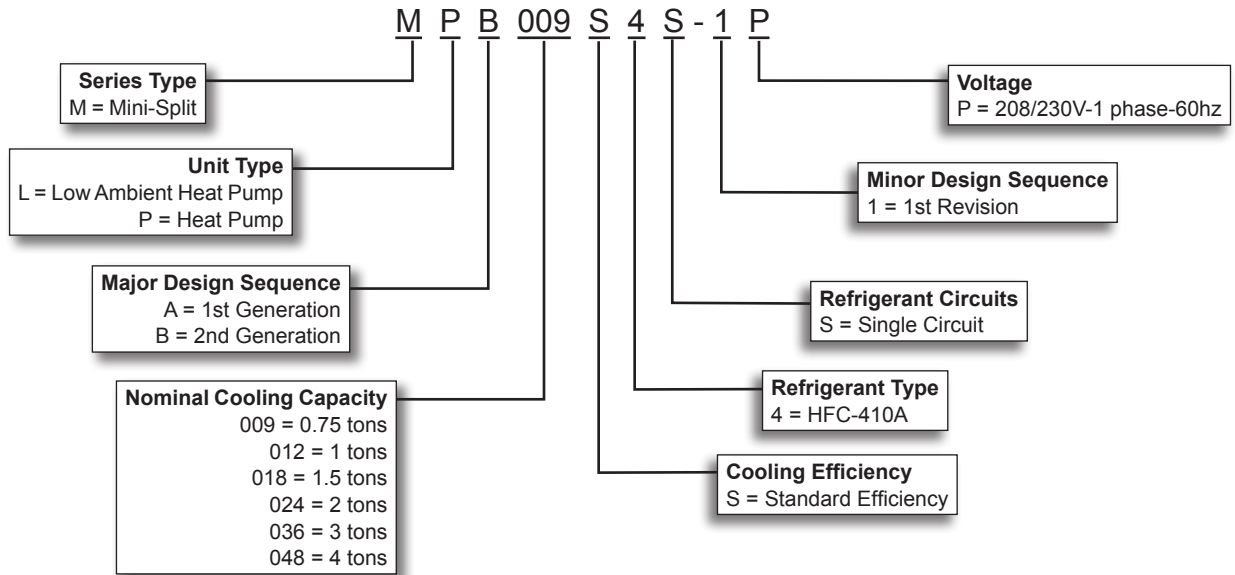

## MEDIUM-STATIC DUCTED INDOOR UNITS

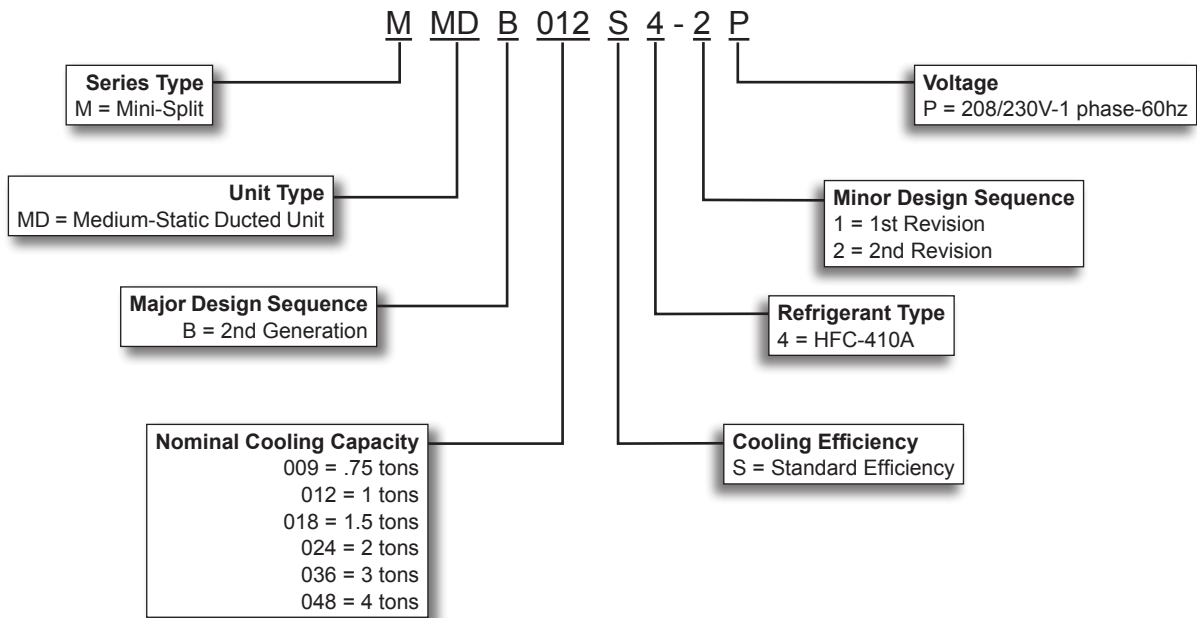

# Typical System Components

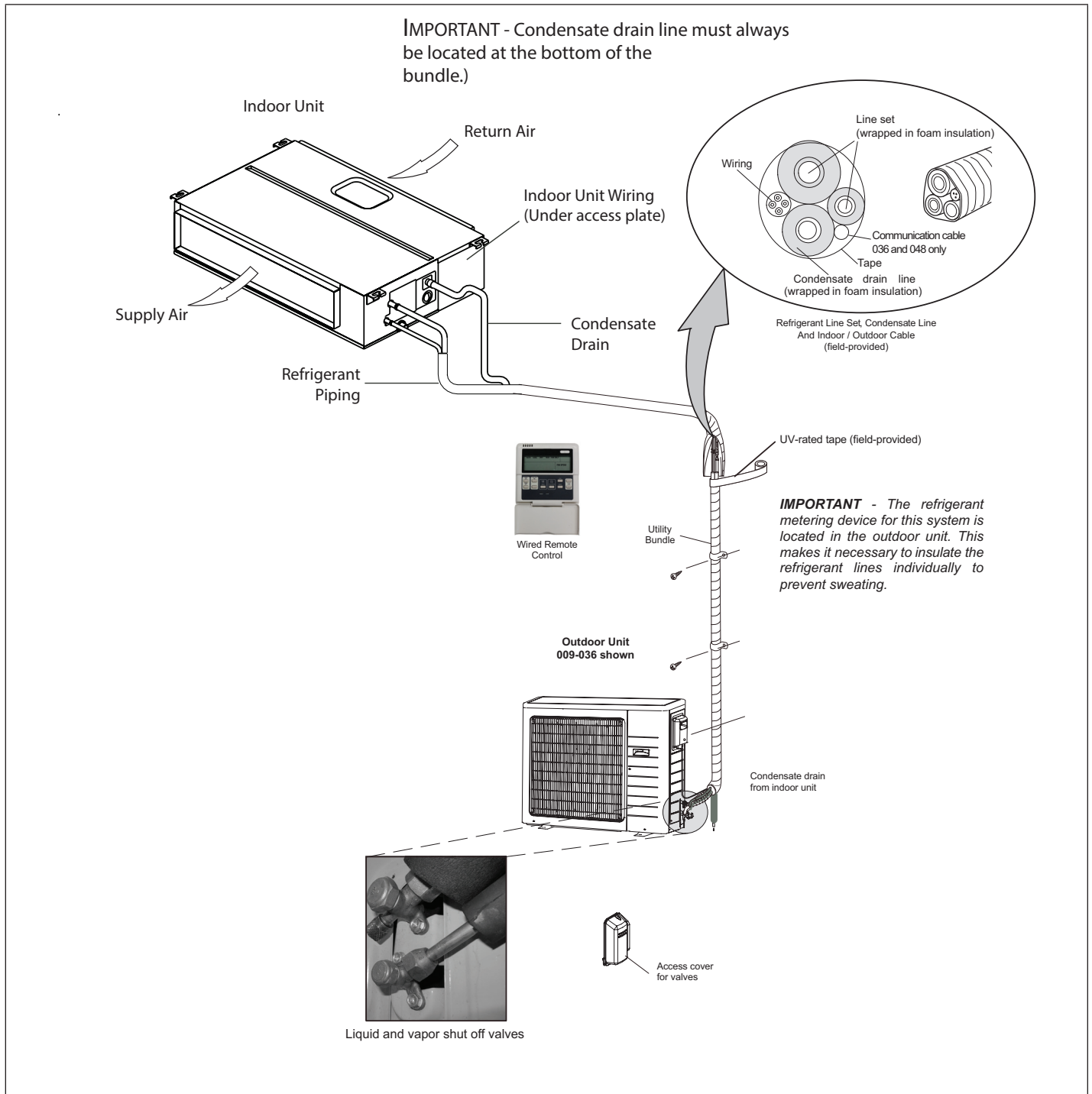

**Figure 1. Typical System Shown**

## System Dimensions

### Outdoor Units

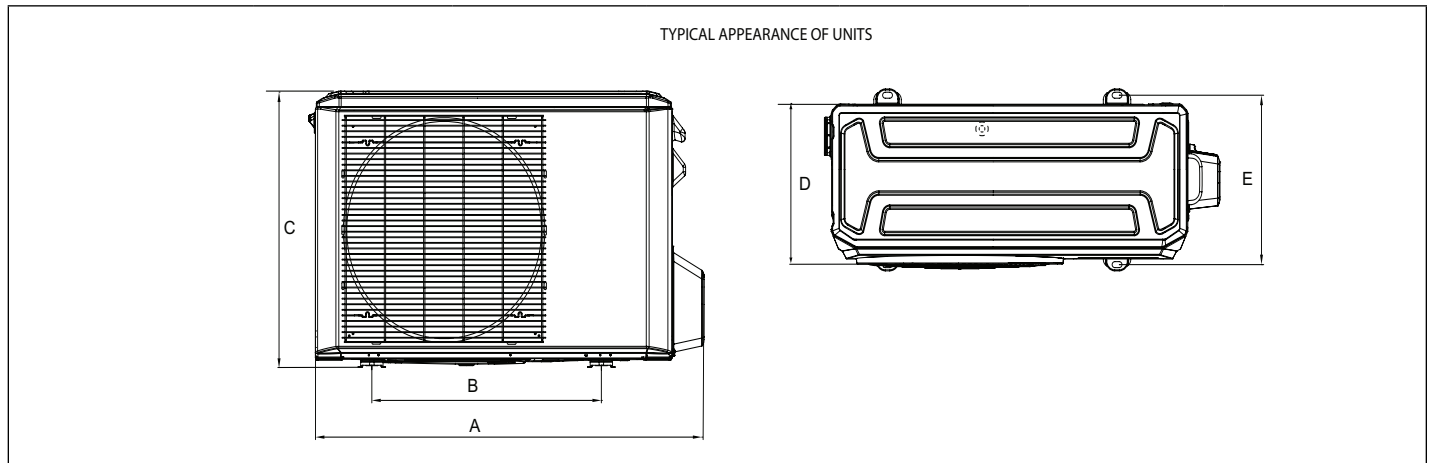

Model	Unit of Measurement	A	B	C	D	E
MPB009S4S-*P	inches	33-1/8	19-1/8	21-7/8	11-7/8	11-3/4
	mm	842	486	556	302	298
MPB012S4S-*P	inches	34-1/4	20-1/4	21-7/8	13-1/8	13-3/8
	mm	870	514	556	333	340
MPB018S4S-*P	inches	36	21-1/4	27-5/8	14-1/4	13-3/4
	mm	914	540	702	362	349
MPB024S4S-*P	inches	37-1/4	26-1/2	31-7/8	16-3/8	15-7/8
MPB036S4S-*P	mm	1032	673	810	416	403
MLA009S4S-*P	inches	34-1/4	20-1/4	21-3/4	12-1/4	13-3/8
MLA012S4S-*P	mm	870	514	552	311	594
MLA018S4S-*P	inches	36	21-1/4	27-5/8	13-3/4	16
	mm	914	540	702	349	406
MLA024S4S-*P	inches	40-3/4	26-1/2	31-7/8	15-1/8	16
	mm	1035	673	810	384	406

Dimensions for MLB036S4S-\*P, MLB048S4S-\*P and MPB048S4S-\*P are listed in Figure 3 on page 6.

**Figure 2. Outdoor Unit Dimensions - inches (mm)**

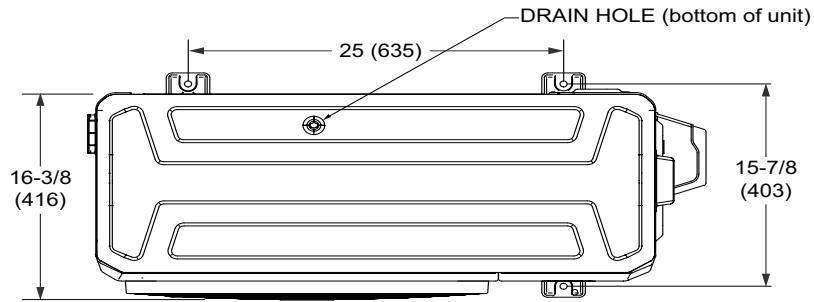

**TOP VIEW**

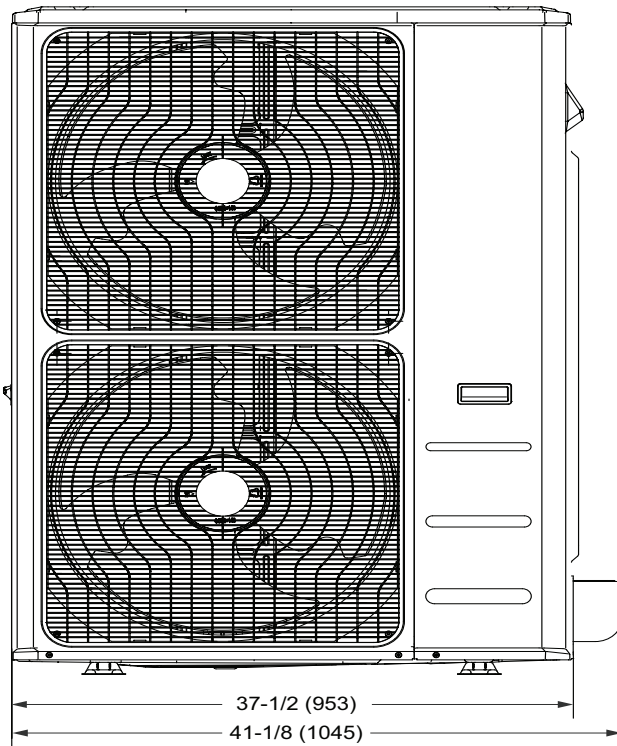

**FRONT VIEW**

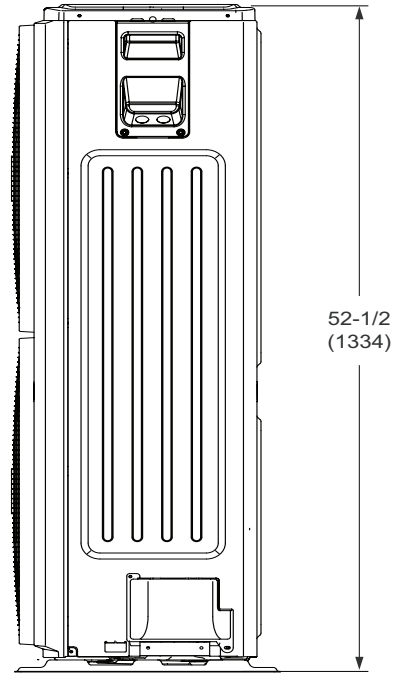

**SIDE VIEW**

**Figure 3. Outdoor Unit Dimensions (MLB036S4S-\*P, MLB048S4S-\*P and MPB048S4S-\*P - Inches (mm))**

# MMDB Indoor Units

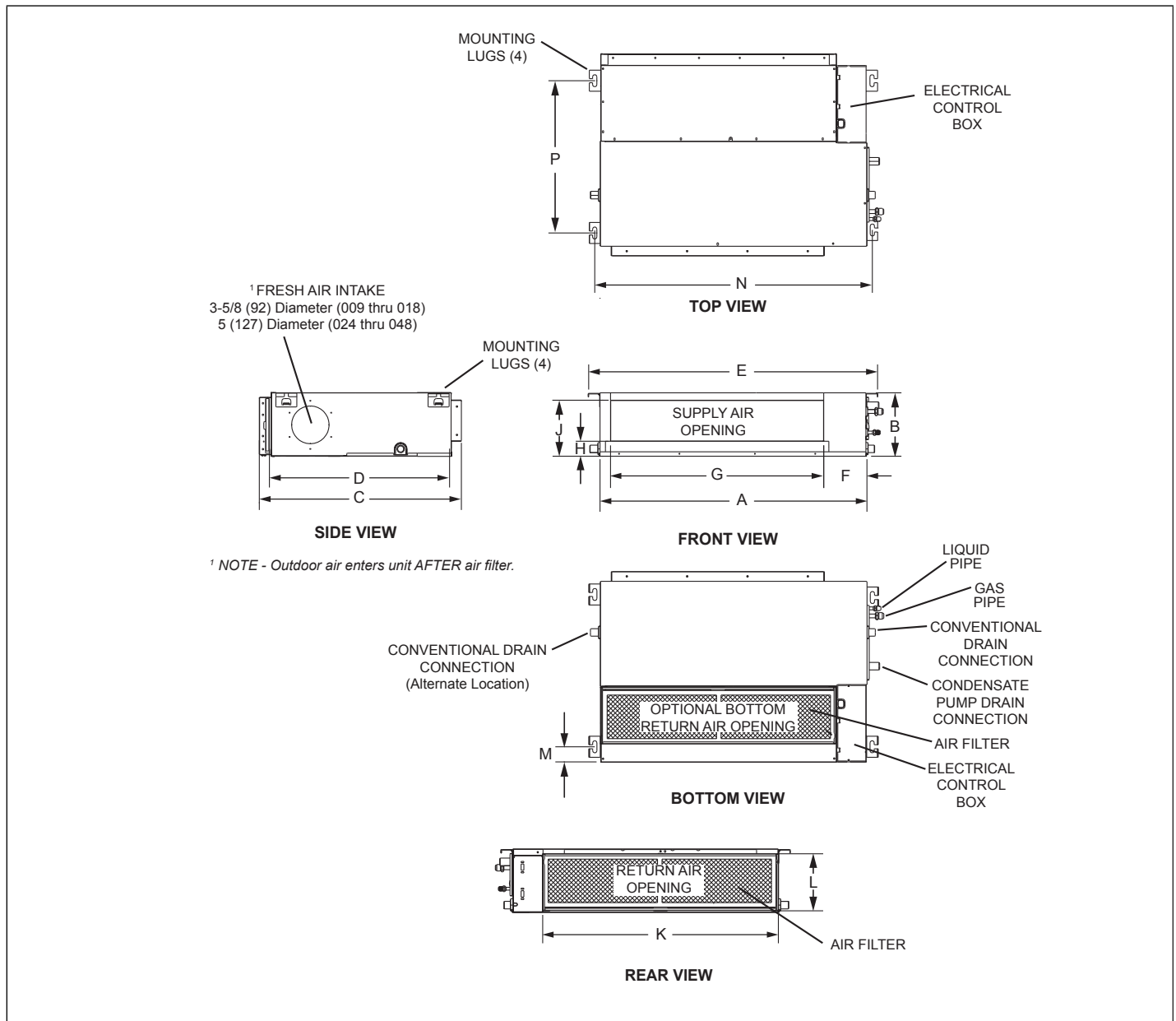

Size	A		B		C		D		E		F		G		H	
	in.	mm	in.	mm	in.	mm	in.	mm	in.	mm	in.	mm	in.	mm	in.	mm
009 thru 012	27-5/8	702	7-7/8	200	19-7/8	505	17-3/4	451	30-3/4	781	5-3/8	137	21-1/8	537	1-1/8	29
018	34-5/8	879	8-1/4	210	26-1/2	673	23-5/8	600	37-7/8	962	5-1/2	140	27-3/4	705	2	51
024	43-1/4	1099	9-3/4	248	30-1/2	775	27-1/2	699	46-1/2	1181	5-1/2	140	36-1/2	927	2	51
036	53-1/2	1359	9-3/4	249	30-1/2	775	27-1/2	699	56-3/4	1441	5-1/2	140	46-3/4	1187	2	51
048	47-1/4	1200	11-7/8	302	34-3/8	873	31-1/2	800	50-1/2	1283	4-7/8	124	41-1/8	1045	2	51

Size	J		K		L		M		N		P	
	in.	mm	in.	mm	in.	mm	in.	mm	in.	mm	in.	mm
009 thru 012	6	152	23-5/8	600	7-3/8	187	2	51	29-1/8	740	14-1/8	359
018	5-3/8	137	30-3/4	781	7-1/2	191	1-5/8	41	36-1/4	921	20	508
024	6-7/8	175	39-3/8	1000	9	229	1/4	6	44-7/8	1140	23-1/2	597
036	6-7/8	175	49-5/8	1260	9	229	1/4	6	55-1/8	1400	23-1/2	597
048	9	229	43-3/8	1102	11	279	1/4	6	48-7/8	1241	27-1/2	699

Figure 4. MMDB Indoor Ducted Unit Dimensions - Inches (mm)

## System Clearances

### OUTDOOR UNIT

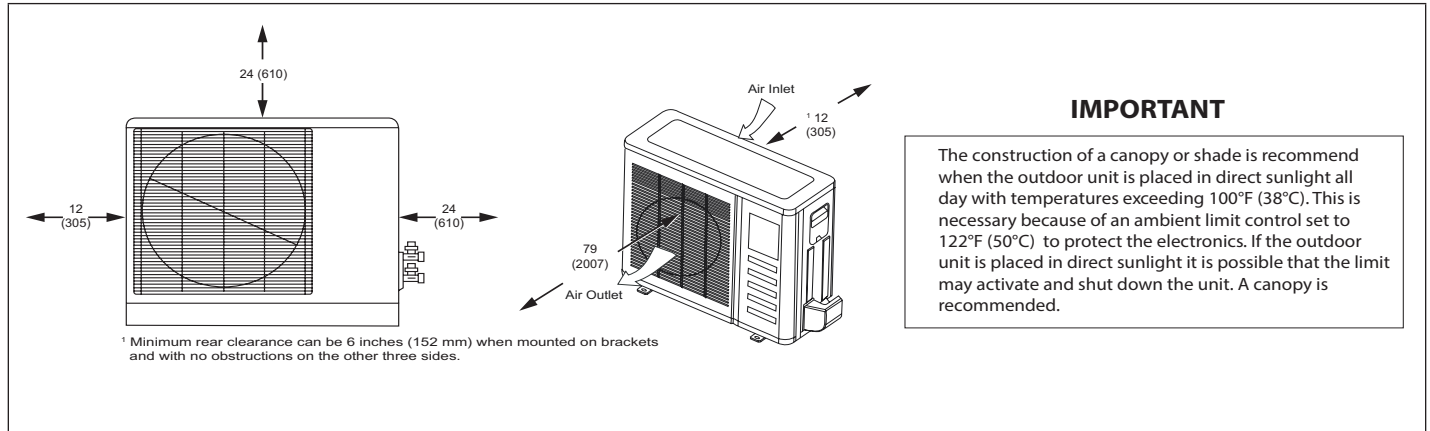

Figure 5. Outdoor Unit Clearances - Inches (mm)

### Indoor Unit

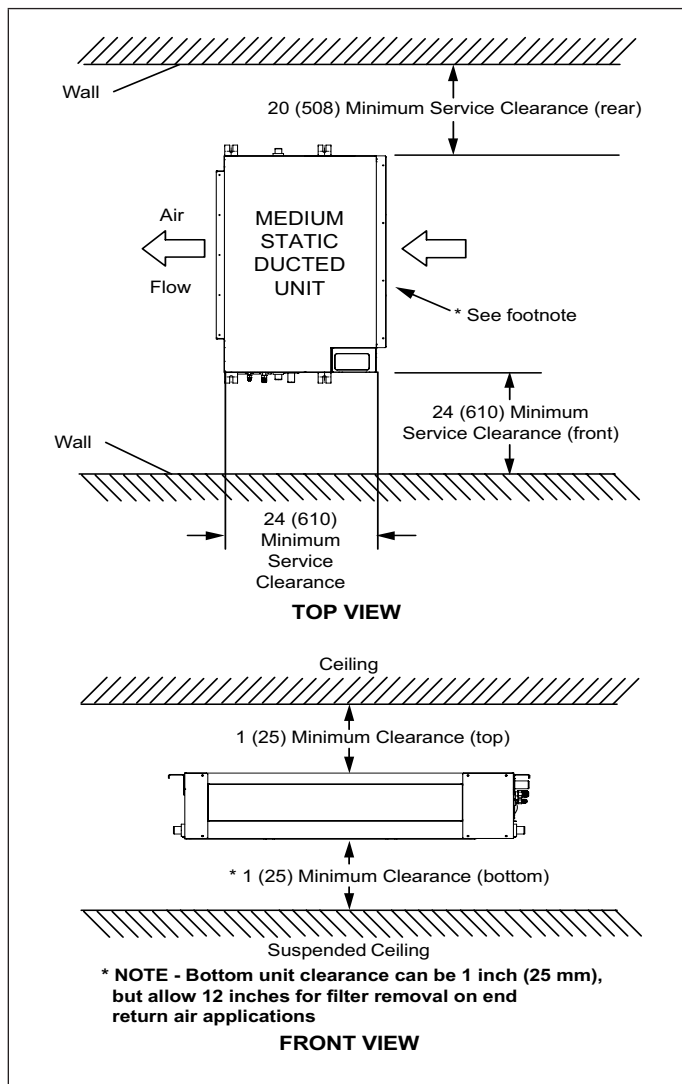

Figure 6. Indoor Unit Clearances - Inches (mm)

### Torque Requirements for Caps and Fasteners

When servicing or repairing HVAC components, ensure the fasteners are appropriately tightened. "Table 1. Torque Requirements" provides torque values for fasteners.

### IMPORTANT

Only use Allen wrenches of sufficient hardness (50Rc - Rockwell scale minimum). Fully insert the wrench into the valve stem recess.

Service valve stems are factory-torqued from 9 ft.-lbs. (12 N\*m) for small valves, to 25 ft.-lbs. (34 N) for large valves) to prevent refrigerant loss during shipping and handling. Using an Allen wrench rated at less than 50Rc risks rounding or breaking off the wrench, or stripping the valve stem recess.

See the Lennox Service and Application Notes C-08-1 for further details and information.

Table 1. Torque Requirements

Parts	Recommended Torque	
	U.S.	Newton-Meter- N
Service valve cap	8 ft.-lb.	11
Sheet metal screws	16 in.-lb.	2
Machine screws #10	27 in.-lb.	3
Compressor bolts	7 ft.-lb.	10
Gauge port seal cap	8 ft.-lb.	11



## Indoor Unit Installation

### ⚠ CAUTION

In order to avoid injury, take proper precaution when lifting heavy objects.

### Unit Placement Considerations

#### AVOID

Do not install the unit in the following locations:

- Areas exposed to petrochemicals or petrochemical products.
- Areas exposed to salt or other corrosive materials or caustic gases.
- Areas exposed to extreme voltage variations (such as factories).
- Tightly enclosed areas that may impede service of the unit.
- Areas exposed to fossil fuels (such as oil or gas in kitchens).
- Areas exposed to strong electromagnetic forces.
- Areas exposed to acids or alkaline detergents.

#### DO

- Place the unit so that it is not exposed to direct sunlight.
- Ensure the structural ceiling can support the weight of the unit.
- Select a location where condensate line will have the shortest run to a suitable drain per local codes.
- Allow sufficient space around unit for proper operation and maintenance.
- Install unit a minimum of 3 feet (1m) away from any antenna, power cord (line) radio, telephone, security system, or intercom. Electrical interference and radio frequencies from any of these sources may affect operation.
- Be sure to instruct customers how to properly operate the unit (especially maintenance of air filter, and operation procedure) by having them carry out operations themselves while looking at the manual provided with the controller.

### Installation

### ⚠ IMPORTANT

It is recommended that Medium Static Ducted Indoor Units not be installed in unconditioned spaces with temperatures above 100°F (38°C).

1. Make sure that the structural ceiling or slab is able to support the weight of the indoor unit. It may be necessary to add extra support.
2. Install suspension rods in the structural

ceiling or concrete slab in a suitable location. If the structural ceiling is constructed of concrete, install anchors to accept four  $\frac{3}{8}$ " threaded rods to suspend the indoor unit. If the structural ceiling includes wooden joists, use angle iron or Unistrut channel fixed securely in place to accept the  $\frac{3}{8}$ " threaded rods.

**NOTE:** Threaded rod is the **ONLY** acceptable method of suspending the unit; do not use chains or straps. See "Figure 7. Suspending Methods".

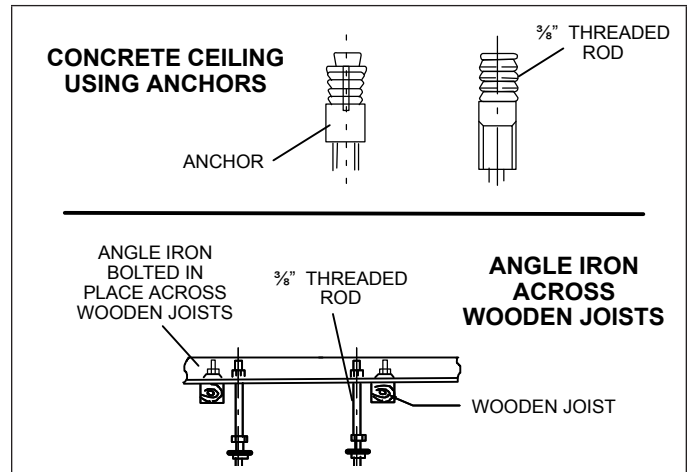

Figure 7. Suspending Methods

3. Slide one nut and one washer onto each threaded rod. Use electrical tape to keep the washer from falling off. Position the nuts slightly above the final resting place of the four suspension brackets. See "Figure 8. Suspending Hardware"
4. Use either a mechanical lifting device or a minimum of two people to raise the unit and insert the threaded rods into the suspension brackets on the unit chassis. Slide a washer and then a nut onto each rod below each suspension bracket. Use the leveling nut (beneath suspension bracket) to adjust the unit to the correct height. Remove the electrical tape holding the upper washers and nuts in place and tighten each of the four nuts above the brackets down onto the brackets. This will ensure that the unit remains level.

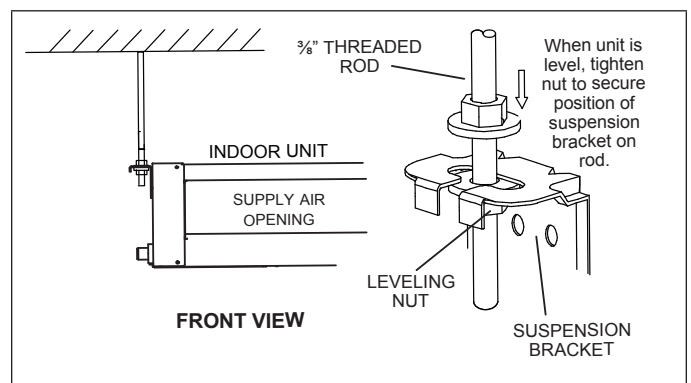
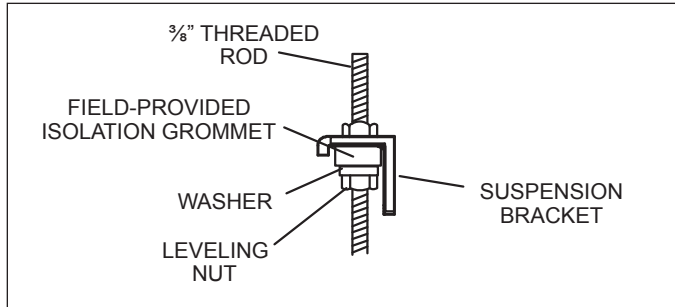

Figure 8. Suspending Hardware

5. If necessary, install a field-provided isolation grommet as shown in "Figure 9. Isolation Grommet" to prevent transmission of vibration from unit to structural ceiling.
6. If the unit is being installed in an application that includes a sheet rock (plasterboard) ceiling, it is required that

an access panel be installed in a suitable location. This will also allow access for future maintenance. Access is required during the start up process to test the condensate disposal system. See “Figure 14. Condensate Drain Test” on page 11.

- The unit is factory-configured for the supply air to be delivered from the front and the return air filter at the rear of the unit. The return air filter location can be relocated in the field for bottom return air filter access, if more convenient. See “Figure 9. Isolation Grommet”.



**Figure 9. Isolation Grommet**

**NOTE:** No part of the suspended ceiling, or other supports not directly associated with the indoor unit installation, can be fixed to, or touch the indoor unit, in any form. Minimum clearances must be observed at all times.

### Installation Guidelines

- Provide separate support for the weight of the duct system. Duct system must not be supported by the indoor unit.
- Use flexible joints (canvas) at the point where the duct connects to the unit on both ends. Material must meet all local and national code requirements.
- When unit is being installed in a location where even the slightest noise would be a problem (meeting room or other very quiet space), design duct system to avoid transmission of vibration to the structure to the extent possible.
- Follow ACCA manual D guidelines for return air filter grille sizing. The return air filter grille should have a minimum surface area of 200 square inch per ton (1290 cm<sup>2</sup> per 3.5kW).

### Field-Relocation of Return Air Filter

Depending on installation requirements, the return air filter may need to be relocated as a bottom return air. See “Figure 10. Field-Relocation of Return Air Filter (Typical) - Bottom Return Air” on page 10 for field-relocating the return air filter.

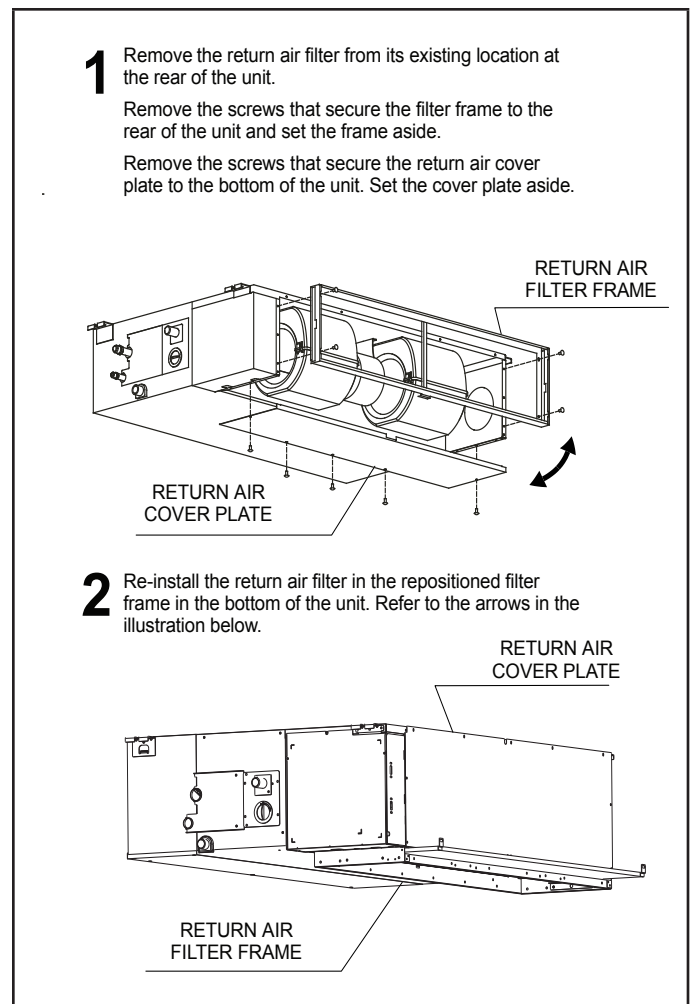

**Figure 10. Field-Relocation of Return Air Filter (Typical) - Bottom Return Air**

### Indoor Unit Condensate Piping Connections

## IMPORTANT

Make sure that drain piping is properly routed and insulated to prevent both leaks and condensation.

- Use a field-provided hose clamp to secure the drain line stub on the side of the unit chassis to a field-supplied 1” (25 mm) drain line.

**NOTE:** Take care not to over-tighten the hose clamp as this may damage the drain line stub.

**NOTE:** Connection between stub and drain line must be watertight. Apply non hardening plumbing joint compound if needed to ensure a watertight seal.

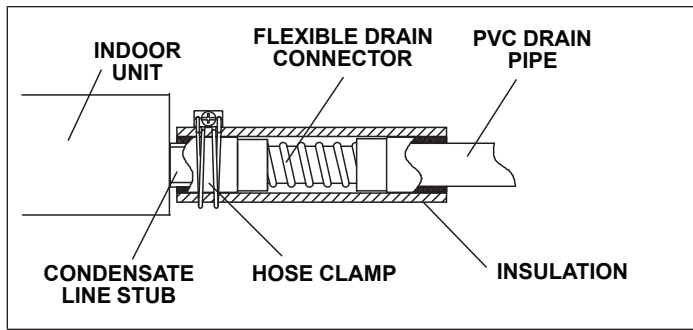

**Figure 11. Condensate Gravity Drain Option**

**NOTE:** If using the gravity drain you must cap the condensate pump drain to prevent condensate from exiting if the gravity drain gets restricted, or disconnect the built-in pump from operating if using gravity connection.

- For applications including an indoor unit and a gravity drain. In this case, ensure that the drain line is properly sloped (no less than 1/4 inch per foot (18 mm per m)) and condensate lines are routed to ensure moisture is drained away from the indoor unit.

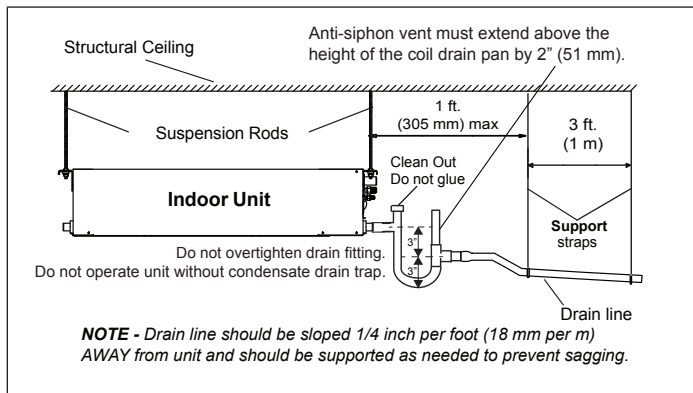

**Figure 12. Slope Condensate Drain**

- For applications including an indoor unit using the internal drain pump.

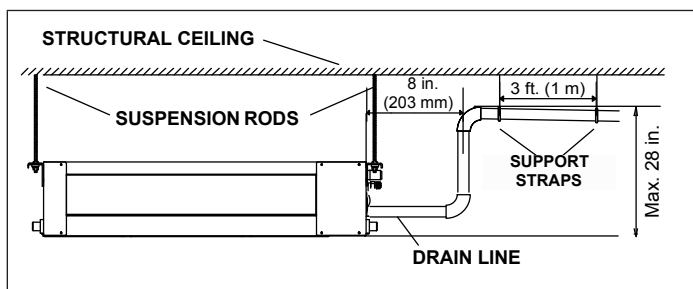

**Figure 13. Condensate Drain with Factory Condensate Pump**

- In all cases, drain should be as short as possible and should not have any droops or kinks that would restrict condensate flow and shall be constructed using an approved pipe. There must be a 2-inch (51 mm) space between the end of the condensate drain and the final termination point (ground, open drain, etc.) to ensure that the line will drain freely.

## IMPORTANT

Drain should have a slope of at least 1/4 inch per foot and should be approved corrosion-resistant pipe. You must confirm operation of every drain and pump in the system as part of the commissioning procedure.

- After system installation is complete, the condensate drain line must be checked for leaks and the condensate pumps must be checked to ensure proper operation. This check is part of the start-up process which must be done by the installing contractor. Turn the condensate drain pan test cover latch counterclockwise to open the cover and access the drain pan. Funnel enough water to engage the pump into the drain pan through a flexible tube.
- Operate the system in the cooling mode. If the internal pump is being used, ensure that the pump is operating and the water in the pan is draining freely. If the internal pump is not being used, pour the water into the drain pan and confirm that it has flowed freely out of the pan and out of the drain termination. If a leak is found, shut down power to the unit at once and do not restore power to the unit until the problem has been resolved.
- Return the test cover and turn the latch clockwise to re-lock it.

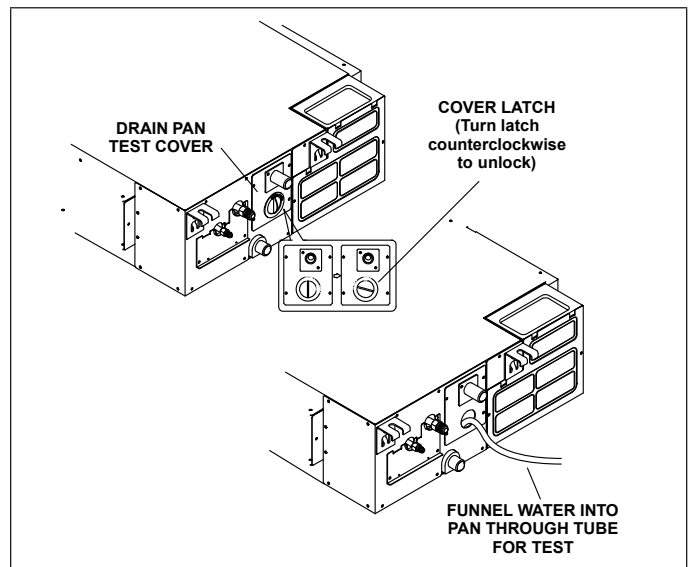

**Figure 14. Condensate Drain Test**

## Outdoor Unit Installation

### CAUTION

In order to avoid injury, take proper precaution when lifting heavy objects.

## Placement Considerations

Consider the following when positioning the unit:

- In coastal areas or other places with salty atmosphere of sulfate gas, corrosion may shorten the life of the unit. In coastal areas, the coil should be cleaned with

potable water several times per year to avoid corrosive buildup (salt).

- Some localities are adopting sound ordinances based on the unit's sound level registered from the adjacent property, not from the property where the unit is installed. Install the unit as far as possible from the property line.
- When possible, do not install the unit directly outside a window. Glass has a very high level of sound transmission.
- Install unit level.

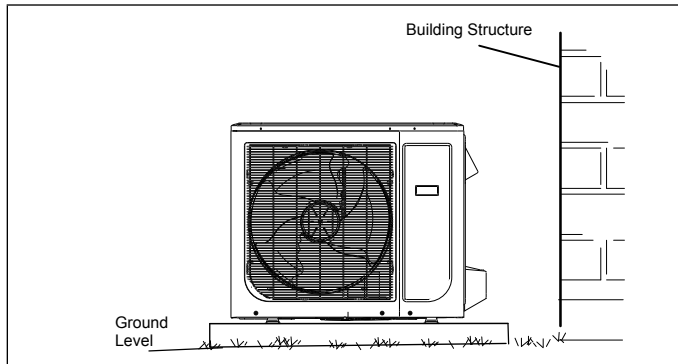

**Figure 15. Install Unit Level**

- Choose a place solid enough to bear the weight and vibration of the unit, where the operation noise will not be amplified.
- Choose a location where the hot air discharged from the unit or the operation noise will not be a nuisance to neighbors.
- Avoid installing the outdoor unit near a bedroom or other places where noise may cause a problem.
- There must be sufficient space to carry the unit into and out of the site.
- There must be unobstructed air flow around the air inlet and the air outlet.
- The unit must not be installed in areas where a flammable gas leak may occur.
- Install the outdoor unit a minimum of 3 feet (1m) away from any antenna, power cord (line), radio, telephone, security system, or intercom. Electrical interference and radio frequencies from any of these sources may affect operation.
- Since water drains from the outdoor unit during various stages of operation, do not place anything which may be damaged by moisture under the unit.

### Direct Sunlight, Rain, Snow and Ice Protection

- If the outdoor unit is subjected to prolong exposure to direct sunlight with temperatures over 100°F (38°C) a canopy is recommended as illustrated in "Figure 16. Outdoor Unit on Pedestal (Stand) and Protective Canopy" or "Figure 21. Dog House-Style Shelter" on page 13.

## IMPORTANT

The construction of a canopy or shade is recommended because of an ambient limit control set to 122°F (50°C) to protect the electronics. If the outdoor unit is placed in direct sunlight it is possible that the limit may activate and shut down the unit.

- Place unit away from overhanging roof lines which would allow water or ice to drop on, or in front of, coil or into unit. Construct a canopy as illustrated in "Figure 16. Outdoor Unit on Pedestal (Stand) and Protective Canopy".
- The unit base should be elevated above the depth of average snows as illustrated in "Figure 17. Outdoor Unit on Brackets above Snow Line".
- In heavy snow areas, do not place the unit where drifting will occur as illustrated in "Figure 18. Outdoor Unit Air Flow Obstructed by Snow".
- Carefully consider how to manage defrost water disposal to prevent ice from blocking walkways or creating a safety hazard near the outdoor unit as illustrated in "Figure 19. Avoid Defrost Water Ice Hazard".

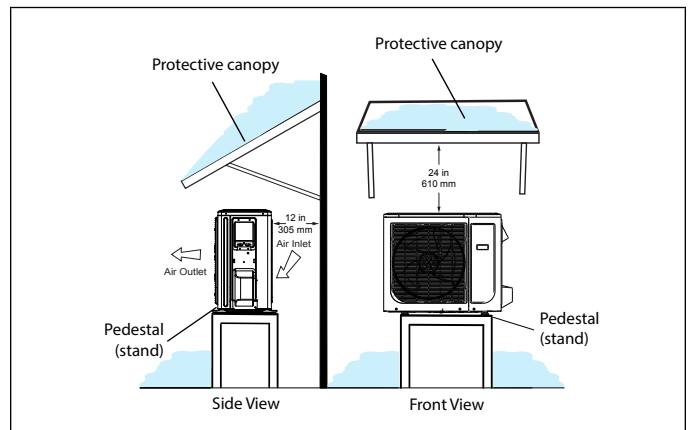

**Figure 16. Outdoor Unit on Pedestal (Stand) and Protective Canopy**

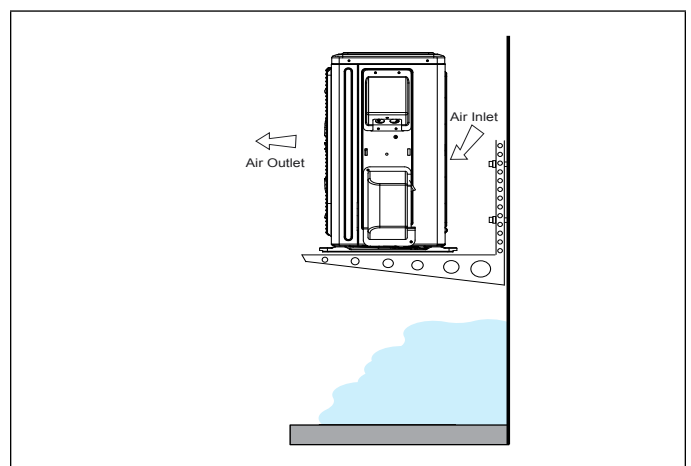

**Figure 17. Outdoor Unit on Brackets above Snow Line**

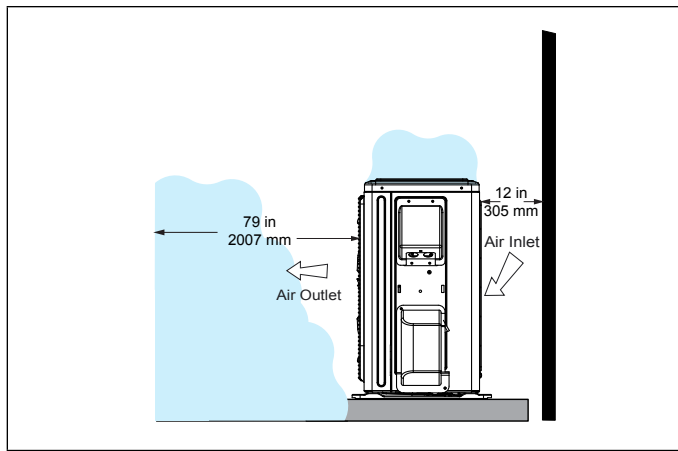

**Figure 18. Outdoor Unit Air Flow Obstructed by Snow**

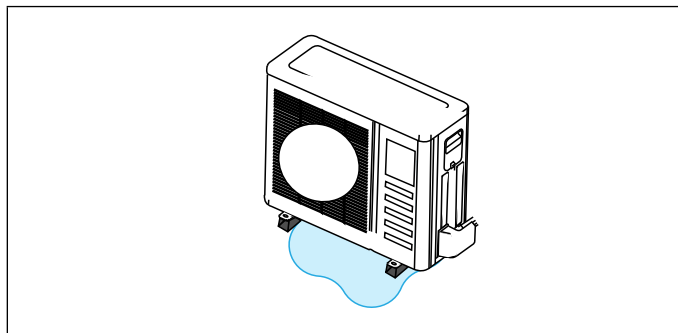

**Figure 19. Avoid Defrost Water Ice Hazard**

### Prevailing Winds

Normally wind baffles are not required for a outdoor unit. However, in order to maximize reliability and performance, the following best practices should be followed.

If unit coil cannot be installed away from prevailing winter winds, some method of protecting the coil is recommended. However, minimum clearances as reference in “Figure 5. Outdoor Unit Clearances - Inches (mm)” on page 8 must be observed at all times.

Common application examples are:

- When prevailing winds are from the air inlet side, then position the wind barrier a minimum of 12 inches (305 mm) from the unit as illustrated in “Figure 20. Wind Barrier”.
- When prevailing wind is into the discharge side, then position the wind barrier a minimum 79 inches (2007 mm) from the front of the unit as illustrated in “Figure 20. Wind Barrier”.
- Outdoor unit can be installed in a dog house style shelter as illustrated in “Figure 21. Dog House-Style Shelter”.
- Outdoor unit can be installed in a alcove or under a roof overhang as illustrated in “Figure 22. Unit installed in Alcove”.

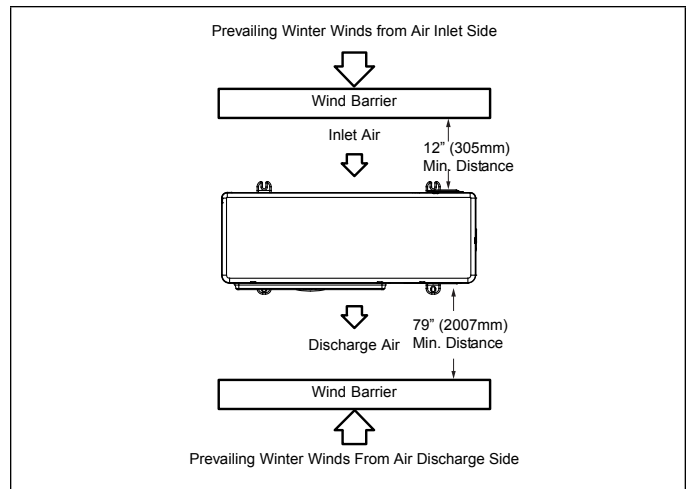

**Figure 20. Wind Barrier**

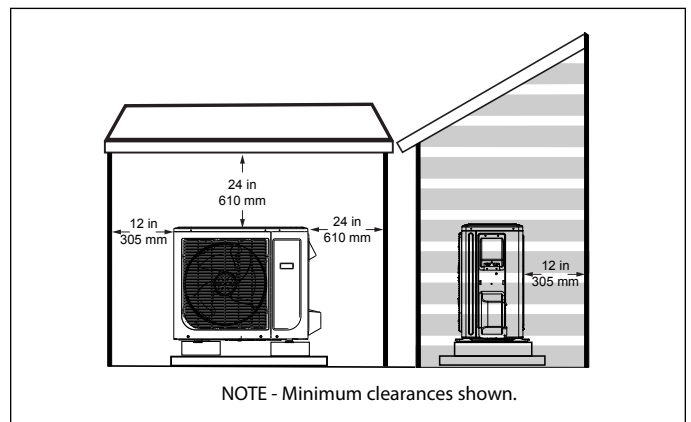

**Figure 21. Dog House-Style Shelter**

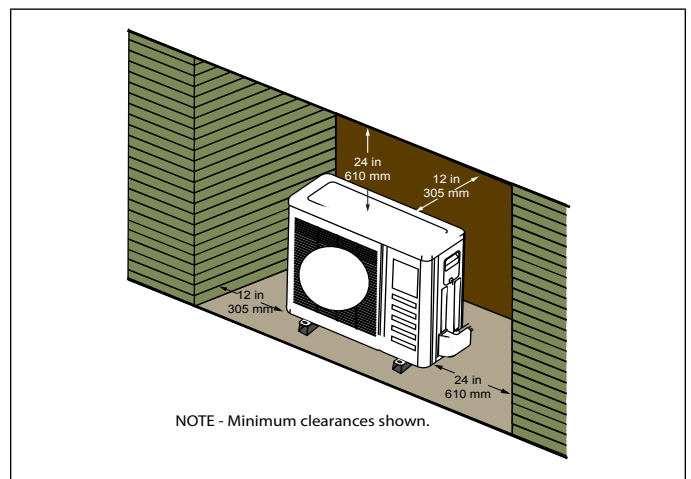

**Figure 22. Unit installed in Alcove**

### Buried Refrigerant Pipe Protection

- **All** refrigerant lines must be insulated regardless of if it is buried.
- In addition to insulating each line of piping, buried lines must rest inside a **sealed, watertight** conduit.
- The conduit must be designed so it cannot collect and retain water.



## Condensate Piping

Condensate formed during the heating and defrost processes must be drained from heat pump units. Drain holes are provided in the base of the units to ensure proper drainage. Heat pumps must be raised when installed on a concrete pad or the ground to allow drainage to occur. If the heat pump unit is installed on wall mounting bracket, insert the provided drain connector into one of the 1 inch (25 mm) drain holes and attached a field-provided insulated drain hose to the connector. Use field-provided rubber plugs to cover any unused drain holes (see "Figure 23. Condensate Drain" on page 14).

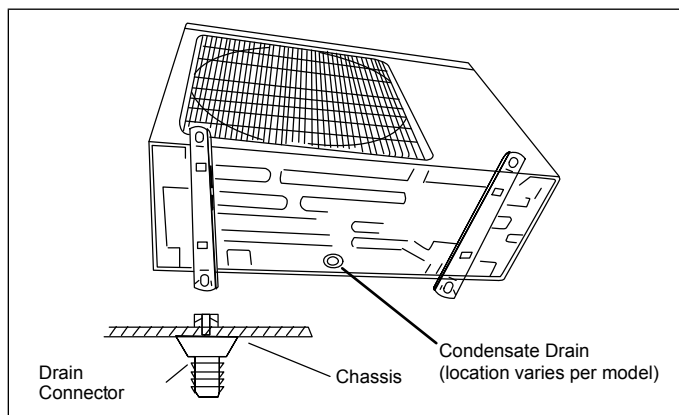

Figure 23. Condensate Drain

## Securing the Outdoor Unit

### Slab or Roof Mounting

Install the unit a minimum of 4 inches (102 mm) above the roof or ground surface to avoid ice build-up around the unit. Place the unit above a load bearing wall or area of the roof that can adequately support the unit. Consult local codes for rooftop applications.

## ! CAUTION

### Roof Damage!

This system contains both refrigerant and oil. Some rubber roofing material may absorb oil. This will cause the rubber to swell when it comes into contact with oil. The rubber will then bubble and could cause leaks. Protect the roof surface to avoid exposure to refrigerant and oil during service and installation. Failure to follow this notice could result in damage to roof surface.

### Securing Outdoor Unit to Slab, Frame, or Rails

If the outdoor unit is installed on a field-provided slab or frame, use lag bolts or equivalent to secure the outdoor unit to the slab or frame.

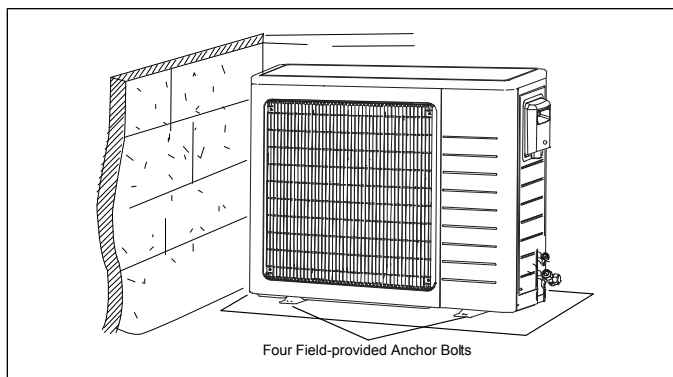

Figure 24. Securing Outdoor Unit to Slab

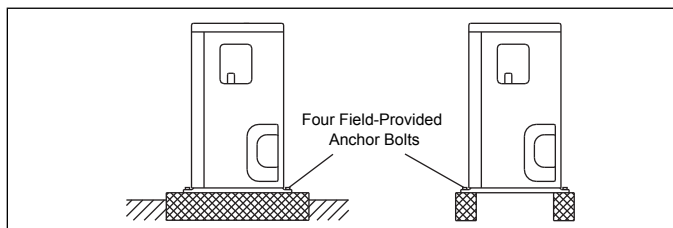

Figure 25. Securing Outdoor Unit to Rails

### Securing Outdoor Unit To Hanging Brackets

If the outdoor unit is installed on field-provided wall mounting brackets, use lag bolts or equivalent to secure the outdoor unit to the bracket. Minimum rear clearance can be reduced to 6 inches (152 mm) when mounted on brackets and with no obstructions on the other three sides. Allow for condensate disposal when placing units above one another.

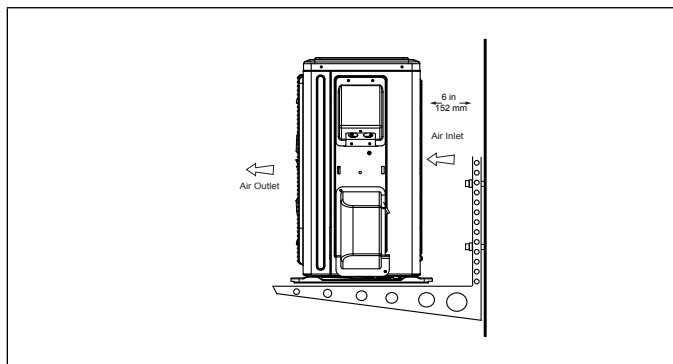

Figure 26. Securing Outdoor Unit to Brackets

## Refrigerant Piping Connections

Field piping consists of two copper lines connecting the outdoor unit to the indoor unit. "Table 3. Refrigerant Piping and Indoor Unit Connection Sizes" on page 15 lists the connection sizes. The connections are made using the provided brass flare nuts at the end of the refrigerant piping connections.

1. Choose the correct pipe sizes for your application using "Table 3. Refrigerant Piping and Indoor Unit Connection Sizes" on page 15.
2. Confirm that you are using the correct diameter piping.

- Determine the necessary piping length required for the application.
- Cut the selected pipes with a pipe cutter. Make the cuts flat and smooth as illustrated in "Figure 27. Cutting Pipe".

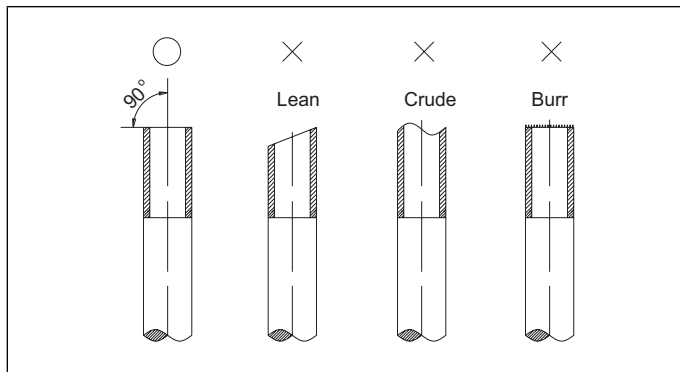

**Figure 27. Cutting Pipe**

- Insulate the copper piping.
- Insert a flare nut onto each pipe before flaring.
- Use "Table 2. Flaring Piping" to properly flare the pipe.

**Table 2. Flaring Piping**

Pipe Diameter	Flare Dimension A (mm)		Flare Shape
	Min	Max	
1/4" (6.35)	8.3	8.7	
3/8" (9.62)	12.0	12.4	
1/2" (9.52")	15.4	15.8	
5/8" (15.9)	18.6	19.1	
3/4" (22.9)	22.9	23.3	

- After flaring the pipe, temporarily sealed pipe ends with adhesive tape to avoid contaminants from entering the pipes.
- The seal on the unit refrigerant piping connections should remain in place until the last possible moment. This will prevent dust or water from getting into the refrigerant piping before it is connected.
- CAREFULLY** adjust refrigerant piping connections to suit the application.
- Slowly loosen one of the flare nuts to release the factory nitrogen charge from the indoor units only.
- Remove the flare nuts from the connections on the unit and discard the seal from each of the piping connections.

- Slide the flare nuts onto the ends of the field-provided refrigerant piping before using a suitable flaring tool to flare the end of the copper pipe.
- Apply recommended HFC-410A refrigerant lubricant to the outside of the flared refrigerant lines.

## IMPORTANT

The compressor in this unit contains PVE oil (Polyvinylether). PVE oil is formulated for hydrofluorocarbon (HFC) refrigerants, such as HFC-410A, which this system contains. While it may have some miscibility properties with mineral-based oil and POE oil (Polyolester), it is not recommended to mix PVE oil with any other type of refrigerant oil.

- Align the threaded connections with the flared refrigerant lines. Tighten the flare nuts slightly at first to obtain a smooth match as illustrated in "Figure 28. Making Connections (Male to Female Connection)".

**Table 3. Refrigerant Piping and Indoor Unit Connection Sizes**

Size (Btuh)	Liquid Line in.	Gas Line in.
9000	1/4	3/8
12000	1/4	1/2
18000	1/4	1/2
24000	3/8	5/8
36000 & 48000	3/8	5/8

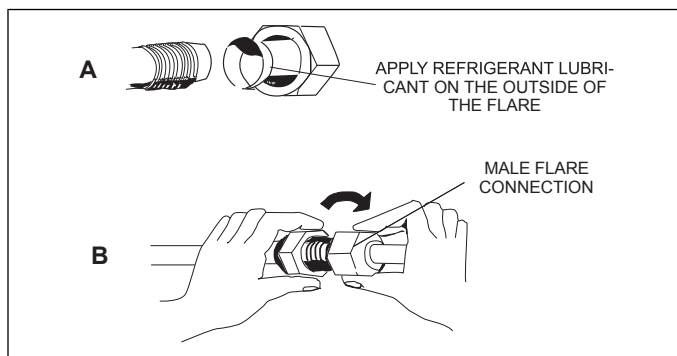

**Figure 28. Making Connections (Male to Female Connection)**

- Once snug, continue another half-turn on each nut which should create a leak-free joint. A torque wrench may be used to tighten flare nuts using table 4 recommendations ("Table 4. Flare Nut Torque Recommendations and Tightening Procedure" on page 16). **Do not over-tighten a flared joint. Flared connections should always be accessible and must be insulated to prevent condensation.**
- After refrigerant piping has been installed and checked for leaks, apply insulation over all flared connections.

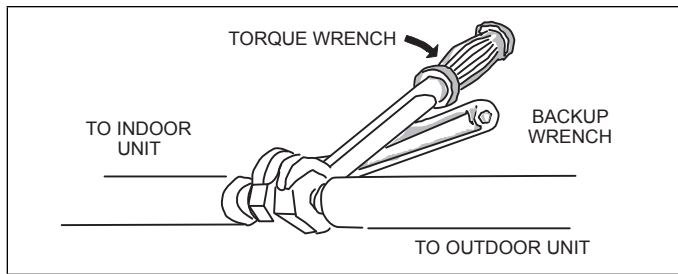

**Figure 29. Tighten Flare Nut**

**Table 4. Flare Nut Torque Recommendations and Tightening Procedure**

Outside Diameter	Recommended Torque	No torque wrench available Finger tighten and use an appropriately sized wrench to turn an additional:
Inches		
1/4	15 ft.-lb. (20 N)	1/4 turn
3/8	26 ft.-lb. (35 N)	1/2 turn
1/2	41 ft.-lb. (56 N)	7/8 turn
5/8	48 ft.-lb. (65 N)	1 full turn

**Table 5. Refrigerant Line Set Requirements**

Outside Unit BELOW Indoor Unit

Outside Unit ABOVE Indoor Unit

**IMPORTANT**

Do not allow for excess length of line sets to be left rolled up as part of the required distance, or in general. This will also cause additional performance issues.

Each system size has a line set length and vertical elevation parameters.

System Size (KBtu)	Line Set Diameters (in.)		Maximum Elevation Outdoor Unit BELOW Indoor Unit - Feet (Meter)	Maximum Elevation Outdoor Unit ABOVE Indoor Unit - Feet (Meter)	Maximum Line Set Length - Feet (Meters)
	Liquid	Gas			
009	1/4	3/8	33 (10)	33 (10)	82 (25)
012	1/4	1/2	33 (10)	33 (10)	82 (25)
018	1/4	1/2	66 (20)	66 (20)	98 (30)
024	3/8	5/8	82 (25)	82 (25)	164 (50)
036/048	3/8	5/8	98 (30)	98 (30)	213 (65)



## Leak Test and Evacuation

Air and moisture remaining in the refrigerant system will have undesirable effects as indicated below:

- Pressure in the system rises.
- Operating current rises.
- Cooling or heating efficiency drops.
- Moisture in the refrigerant circuit may freeze.
- Water may lead to corrosion of parts in the refrigeration system.

The line set between the indoor and outdoor units must be leak tested and evacuated to remove any non-condensables and moisture from the system.

### Leak Test

Use the following procedure to test for system leaks:

1. Connect the manifold gauge set and dry nitrogen gas cylinder to the liquid and gas service ports.
2. Open valve on nitrogen cylinder.
3. Pressurize the system per the pressure test specifications in "Table 6. Pressure Test Specifications"
4. Check that the system pressure remains stable. If there is any movement check system for leaks.
5. After the system is found to be free of leaks:
  - Close valve on nitrogen cylinder.
  - Relieve the nitrogen pressure by: loosening the charge hose connector at the nitrogen cylinder.
  - When the system pressure is reduced to normal, disconnect the hose from the cylinder.

**Table 6. Pressure Test Specifications**

	Bar	Psig	kPa	Duration
1	3	44	303	Minimum of 10 minutes
2	15	220	1517	Minimum of 10 minutes
3	32	470	3241	Minimum of 10 minutes
4	45	650	4482	1 hour. Stress test to prove the integrity of the complete installation.
5	32	470	3241	24 hours. Lower system pressure test, after confirmation No. 4 was successfully completed.

### Triple Evacuation Procedure

A Micron or Torr gauge must be used for this procedure.

1. Discharge the oxygen-free nitrogen and evacuate the system to a reading of 8000 Microns (8 Torr) using all service valves.
2. Break the vacuum by allowing nitrogen into the port connections (liquid and gas line pipes) until a positive pressure is achieved.
3. Evacuate the system to a reading of 5000 Microns (5 Torr).

4. Break the vacuum by allowing nitrogen into the port connections (liquid and gas line pipes) until a positive pressure is achieved.
5. Evacuate the system to a minimum reading of 500 Microns (0.5 Torr).
6. For a moisture-free system, ensure the vacuum is held without movement for a minimum of 4 hours.
7. If vacuum fails to hold, carry out steps 2 through 6 until vacuum holds.

## Wiring Connections

### ! WARNING

Electric Shock Hazard. Can cause injury or death. Unit must be rounded in accordance with national and local codes.

Line voltage is present at all components when unit is not in operation. Disconnect all remote electric power supplies before opening access panel. Unit may have multiple power sources.

### IMPORTANT

All diagrams are typical wiring diagrams. Refer to the wiring diagram on the unit for actual wiring.

### ! CAUTION

All terminal connections must be made as illustrated in the following diagrams. Improperly connected wiring could damage unit or cause communication errors between indoor and outdoor units.

In the U.S.A., wiring must conform with current local codes and the current National Electric Code (NEC). In Canada, wiring must conform with current local codes and the current Canadian Electrical Code (CEC).

### Outdoor Unit

- Refer to unit nameplate for minimum circuit ampacity and maximum over-current protection size.
- Make all electrical power wiring connections at the outdoor unit.
- Be sure to reattach all electrical box covers after connections are complete.

### Indoor Unit

- All indoor units are powered by the outdoor unit.
- See wiring diagrams for specific wire size requirements based on unit sizes.
- When installing a condensate pump, wire in-line with the CN5 float switch.

# IMPORTANT

This unit must be properly grounded and protected by a circuit breaker. The ground wire for the unit must not be connected to a gas or water pipe, a lightning conductor or a telephone ground wire.  
 Do not connect power wires to the outdoor unit until all other wiring and piping connections have been completed.  
 Do not install the unit near a lighting appliance that includes a ballast. The ballast may affect remote control operation.

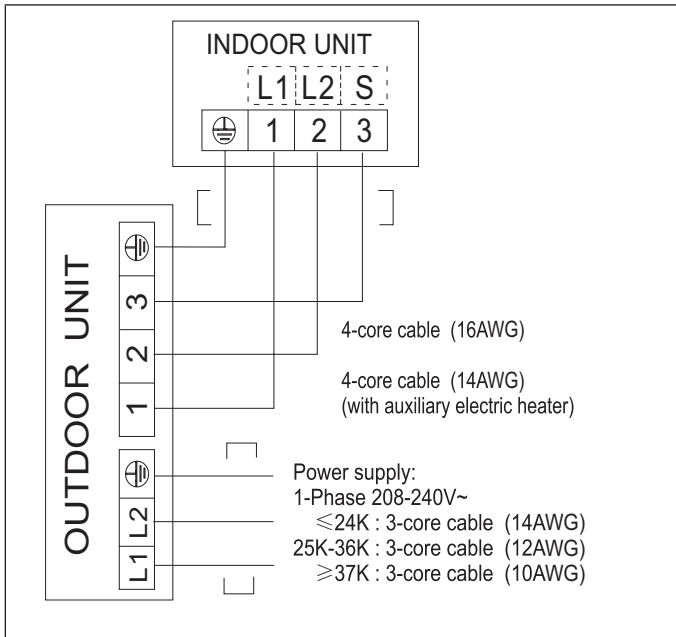

**Figure 30. Single-Zone Wiring 9K, 12K, 18K and 24K**

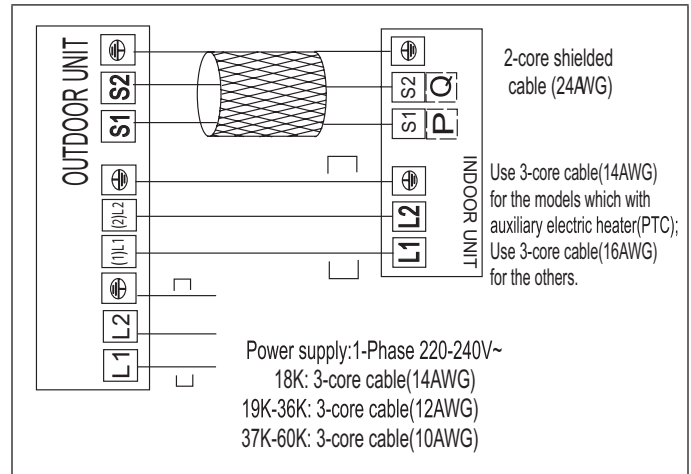

**Figure 31. Single-Zone Wiring 36K and 48K**

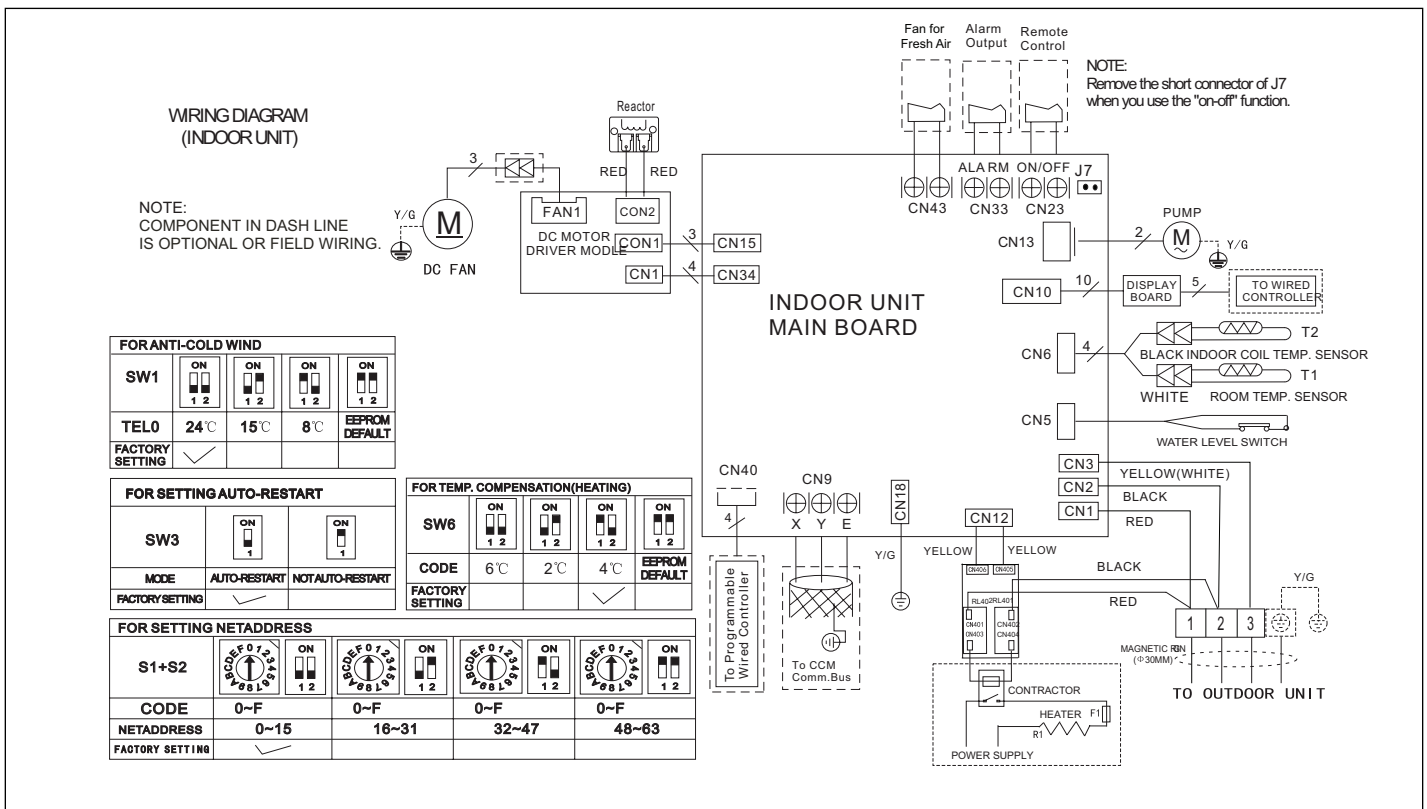

**Figure 32. MMDB009S4-\*P, MMDB012S4-\*P, MMDB018S4-\*P and MMDB024S4-\*P Ducted Units Wiring Diagram**

FOR ANTI-COLD WIND			
SW1	<input type="checkbox"/> ON <input type="checkbox"/> 1 2	<input type="checkbox"/> ON <input type="checkbox"/> 1 2	<input type="checkbox"/> ON <input type="checkbox"/> 1 2
TELO	24°C	15°C	8°C
TELO	Eeprom DEFAULT		
FACTORY SETTING	<input checked="" type="checkbox"/>		

FOR SETTING AUTO-RESTART		
SW3	<input type="checkbox"/> ON <input type="checkbox"/> 1	<input type="checkbox"/> ON <input type="checkbox"/> 1
MODE	AUTO-RESTART	NOT AUTO-RESTART
FACTORY SETTING	<input checked="" type="checkbox"/>	

FOR MAIN-SLAVE SETTING			
SW5	<input type="checkbox"/> ON <input type="checkbox"/> 1 2	<input type="checkbox"/> ON <input type="checkbox"/> 1 2	<input type="checkbox"/> ON <input type="checkbox"/> 1 2
MODE	MAIN NO SLAVE	MAIN	SLAVE
FACTORY SETTING	<input checked="" type="checkbox"/>		

NOTE:  
COMPONENT IN DASH LINE  
IS OPTIONAL OR FIELD WIRING.

FOR TEMP. COMPENSATION (HEATING)			
SW6	<input type="checkbox"/> ON <input type="checkbox"/> 1 2	<input type="checkbox"/> ON <input type="checkbox"/> 1 2	<input type="checkbox"/> ON <input type="checkbox"/> 1 2
CODE	6°C	2°C	4°C
FACTORY SETTING	<input checked="" type="checkbox"/>		

FOR SETTING POWER (DC MOTOR MODEL ONLY)						
ENC1	<input type="checkbox"/> 4	<input type="checkbox"/> 5	<input type="checkbox"/> 7	<input type="checkbox"/> 8	<input type="checkbox"/> 9	<input type="checkbox"/> A
CODE	4	5	7	8	9	A
POWER	≤53	54~71	72~90	91~105	106~140	141~160
FACTORY SETTING	ACCORDING TO RELATED MODEL.					

FOR SETTING NET ADDRESS					
S1+S2	<input type="checkbox"/> 0~F	<input type="checkbox"/> 0~F	<input type="checkbox"/> 0~F	<input type="checkbox"/> 0~F	<input type="checkbox"/> 0~F
CODE	0~F	0~F	0~F	0~F	0~F
NET ADDRESS	0~15	16~31	32~47	48~63	
FACTORY SETTING	<input checked="" type="checkbox"/>				

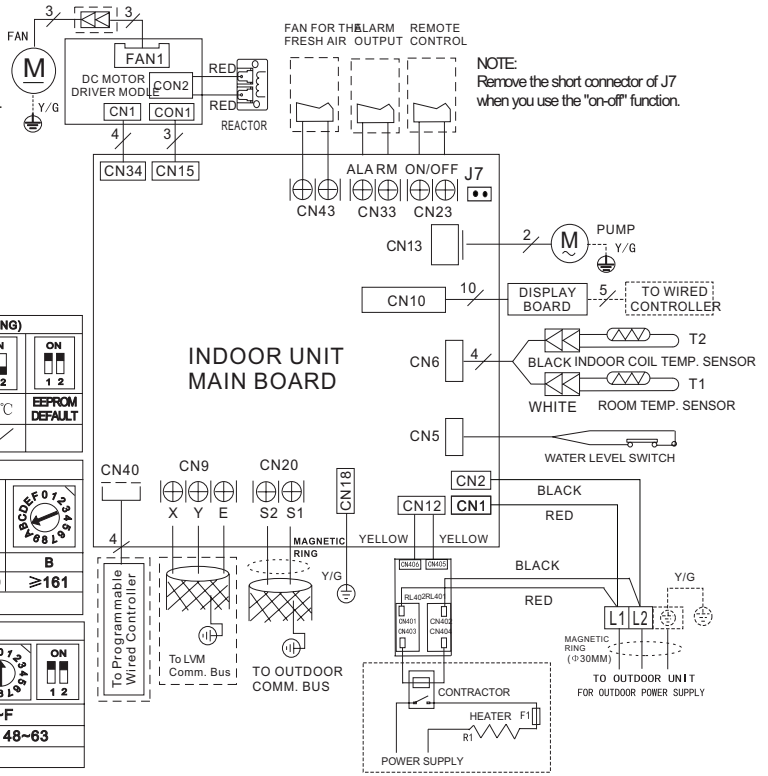

Figure 33. MMDB036S4-\*P and MMDB048S4-\*P Ducted Units Wiring Diagram

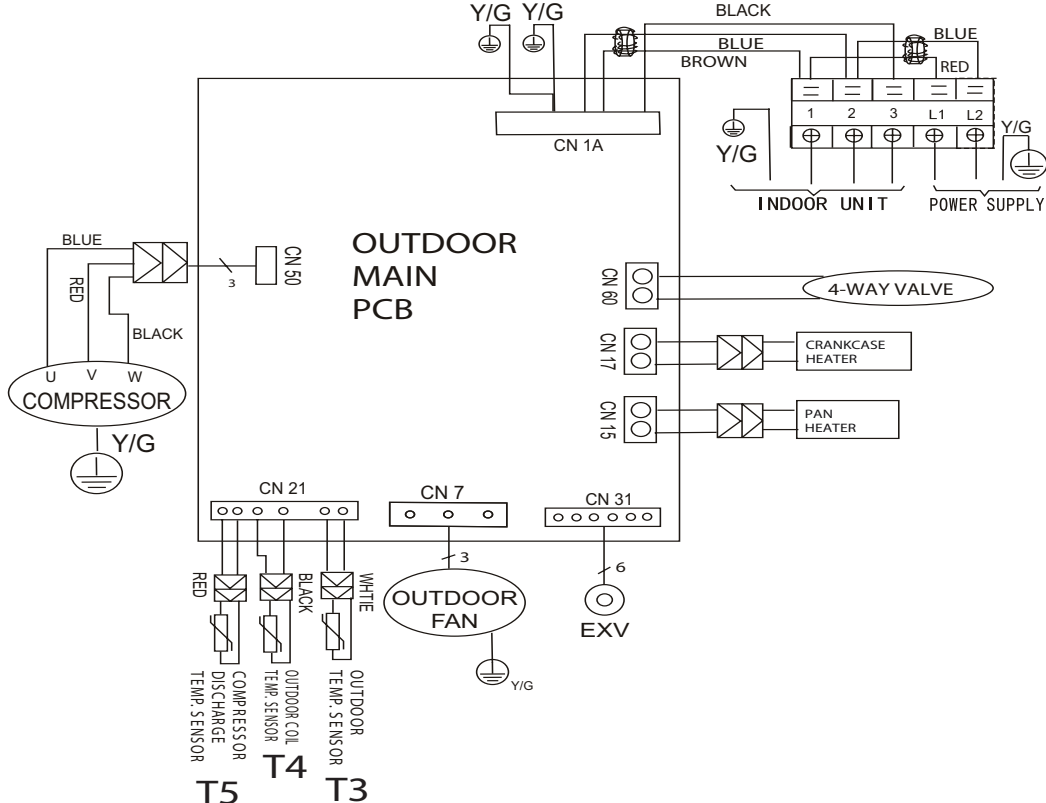

Figure 34. 208/230V MPB009S4S-\*P and MPB012S4S-\*P Outdoor Unit Wiring Diagram

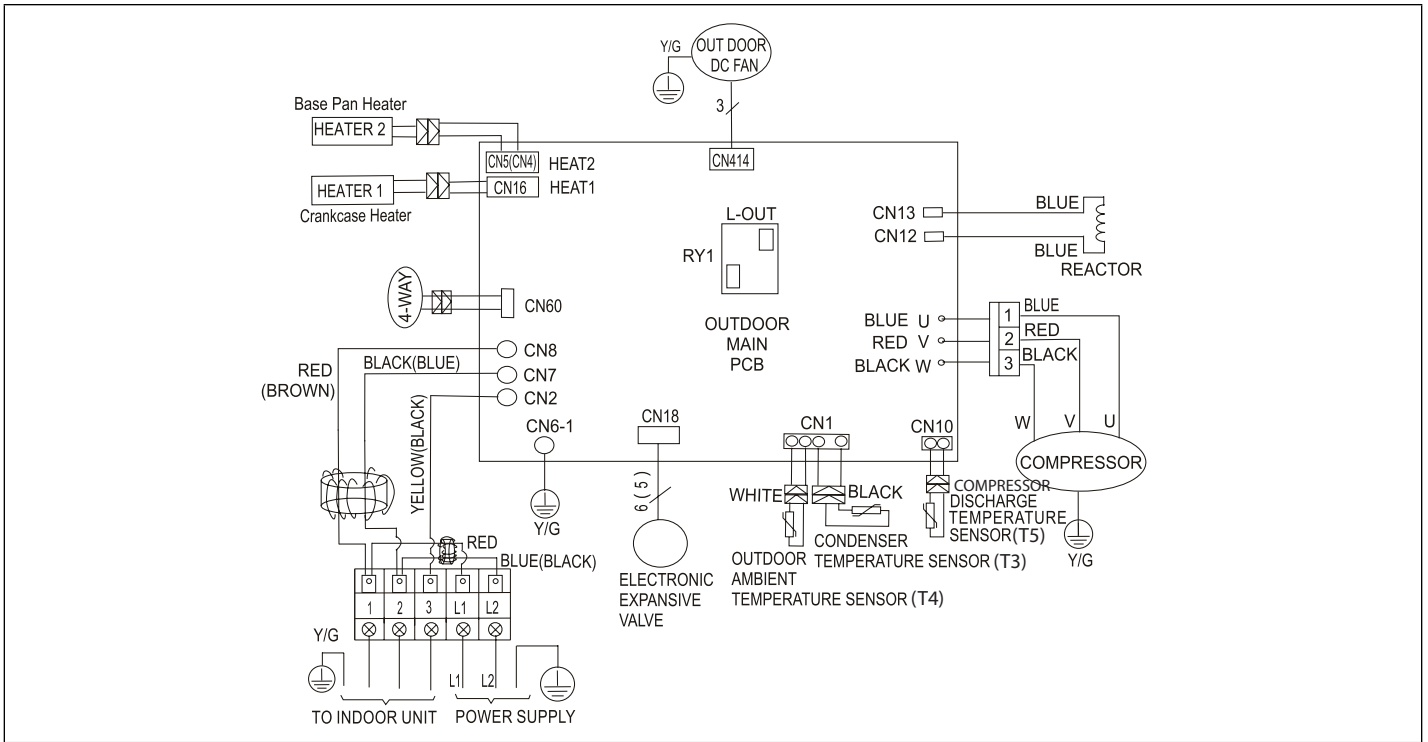

Figure 35. 208/230V MPB018S4S-\*P and MPB024S4S-\*P Outdoor Unit Wiring Diagram

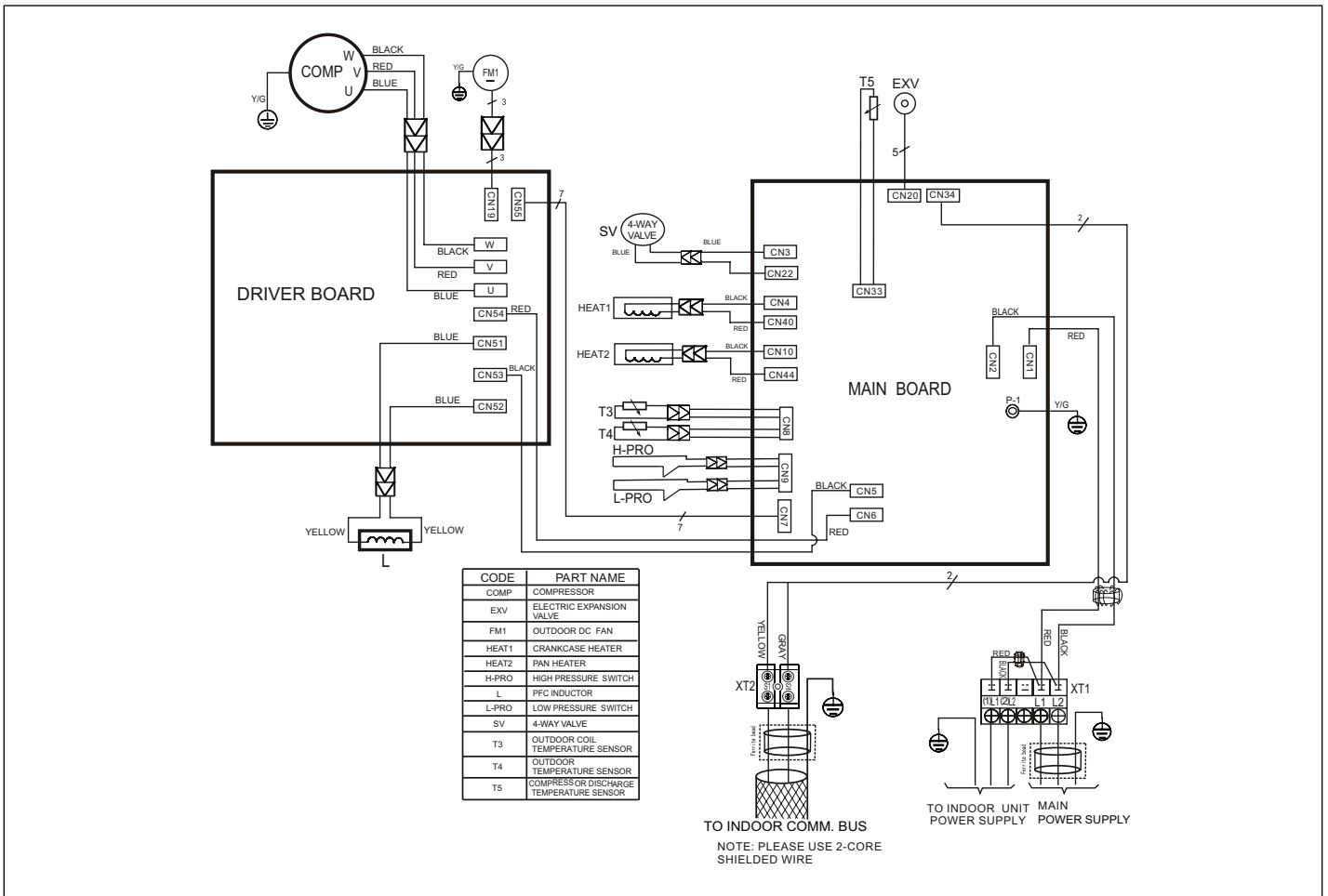

Figure 36. 208/230V MPB036S4S-\*P Outdoor Unit Wiring Diagram

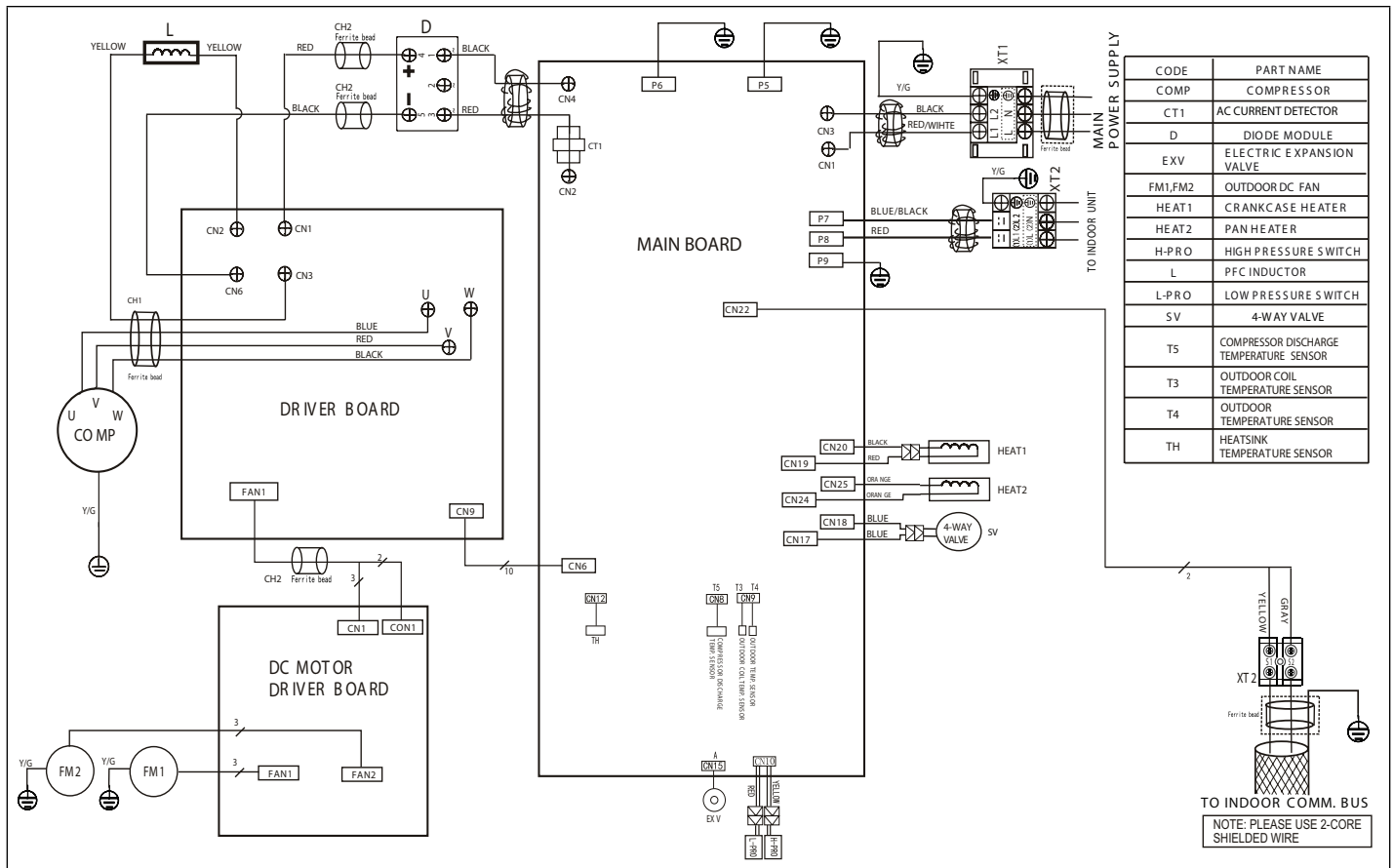

Figure 37. 208/230V MPB048S4S-\*P Outdoor Unit Wiring Diagram

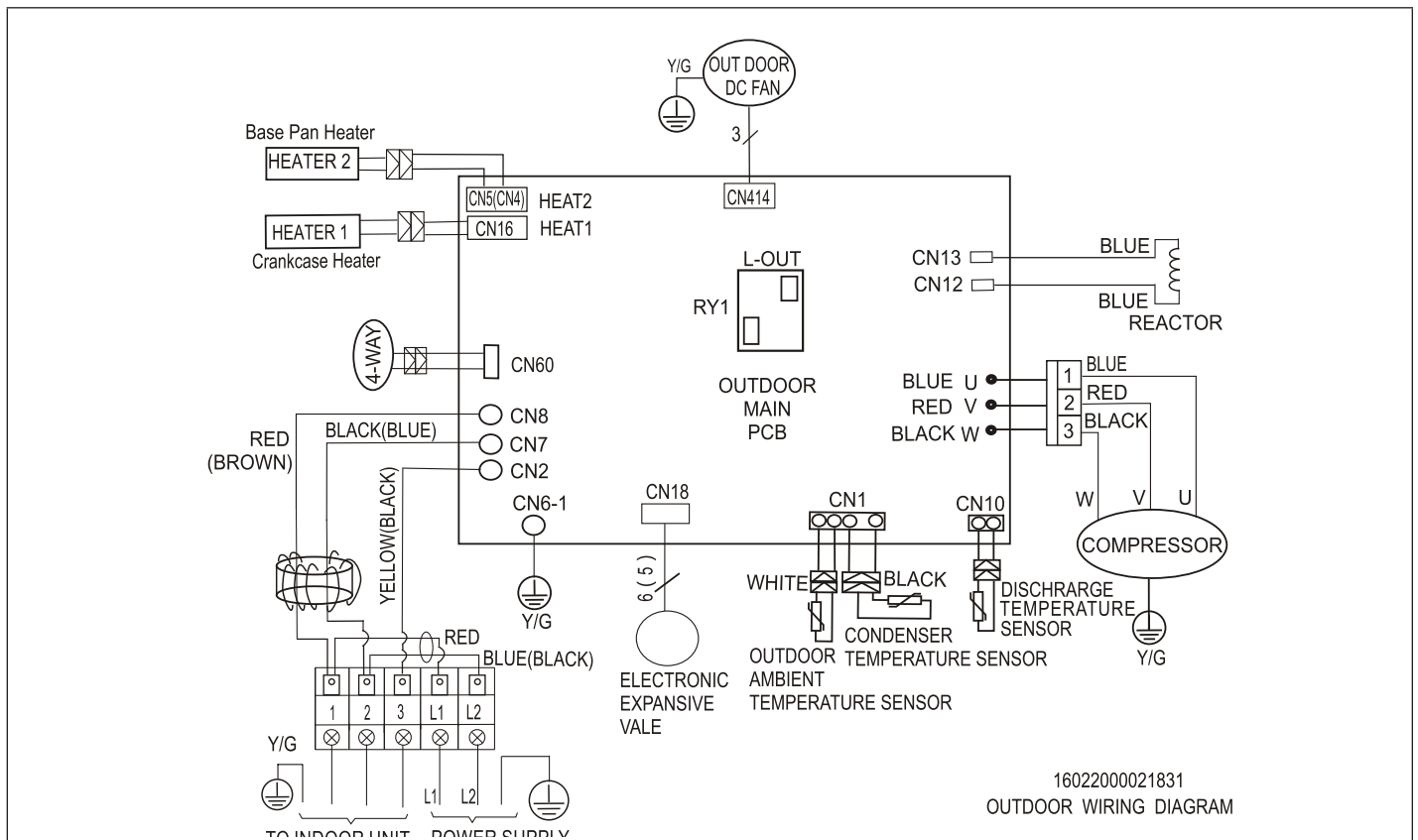

Figure 38. 208/230V MLA009, 012 and 018S4S-\*P Outdoor Unit Wiring Diagram

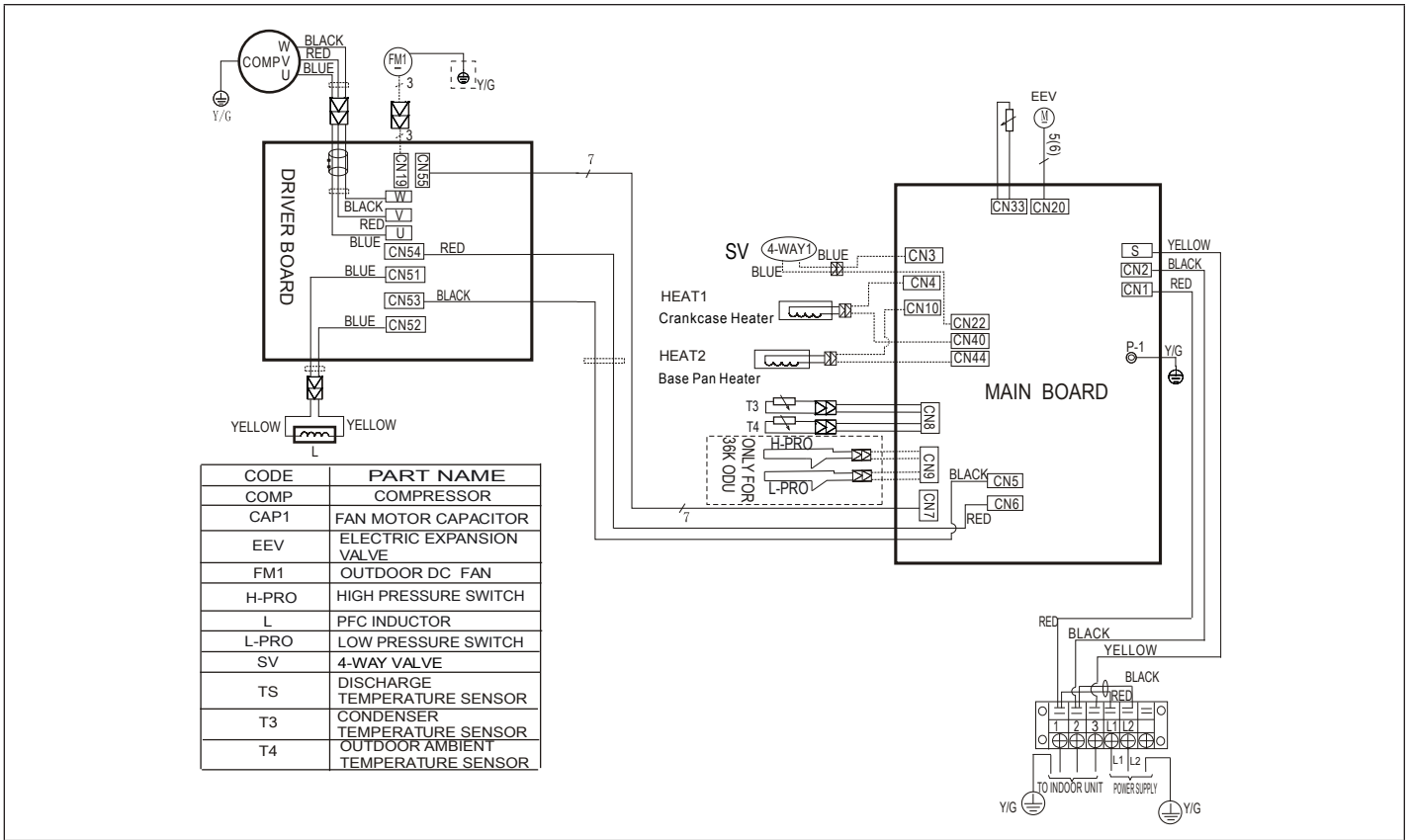

Figure 39. 208/230V MLA024S4S-\*P Outdoor Unit Wiring Diagram

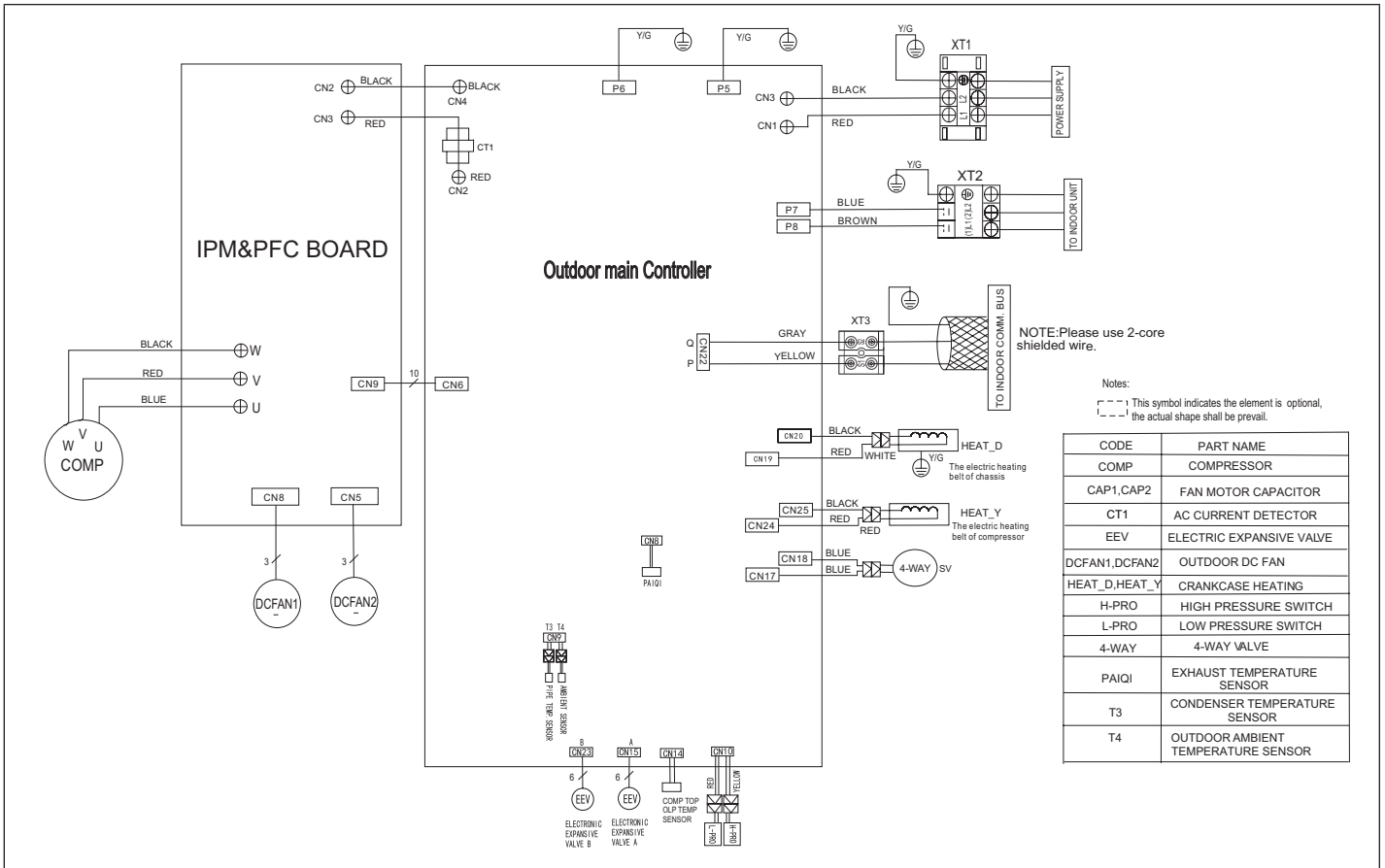

Figure 40. 208/230V MLB036S4S-\*P and MLB048S4S-\*P Outdoor Unit Wiring Diagram

## Unit Start-Up

# IMPORTANT

Units should be energized 24 hours before unit start-up to prevent compressor damage as a result of slugging.

1. Inspect all factory and field-installed wiring for loose connections.
2. Verify that the manifold gauge set is connected.
3. Add additional refrigerant charge if required before opening valves and while system is still under a vacuum.
4. Open the liquid and gas line service valves to release the refrigerant charge contained in outdoor unit into the system.
5. Replace the stem caps and tighten to the value listed in "Table 4. Flare Nut Torque Recommendations and Tightening Procedure" on page 16.
6. Check voltage supply at the outdoor unit terminal strip. The voltage must be within the range listed on the unit's nameplate. If not, do not start the equipment until you have consulted with the power company and the voltage condition has been corrected.
7. Refer to the included user guide to operate the system using the provided remote control.
8. Visually check for binding of both indoor and outdoor fans.

## Adding Refrigerant for Longer Line Set

The outdoor unit is factory-charged with refrigerant. Calculate the additional refrigerant required according to the diameter and the length of the liquid pipe between the outdoor unit and indoor unit connections.

Be sure to add the proper amount of additional refrigerant. Failure to do so may result in reduced performance.

**Table 7. Additional Refrigerant Charge**

System Size (KBtu)	Pipe Length (feet / meters)	Amount of Refrigerant to add
09	>25 (7.5)	0.161 oz/ft (15g/m)
12	>25 (7.5)	0.161 oz/ft (15g/m)
18	>25 (7.5)	0.161 oz/ft (15g/m)
24	>25 (7.5)	0.322 oz/ft (30g/m)
36	>25 (7.5)	0.322 oz/ft (30g/m)
48	>25 (7.5)	0.322 oz/ft (30g/m)

## Setting Airflow Rate

The static pressure airflow rate can be adjusted by using the included M0STAT61Q-1 Wired controller.

1. Turn off the system if it is on.
2. Press the MODE and FAN button simultaneously for three seconds.
3. Press ▲ or ▼ buttons to select the SP option.
4. Press MODE to set the airflow range. Options are 1 through 4.
5. Press the ON/OFF button to finish the procedure.

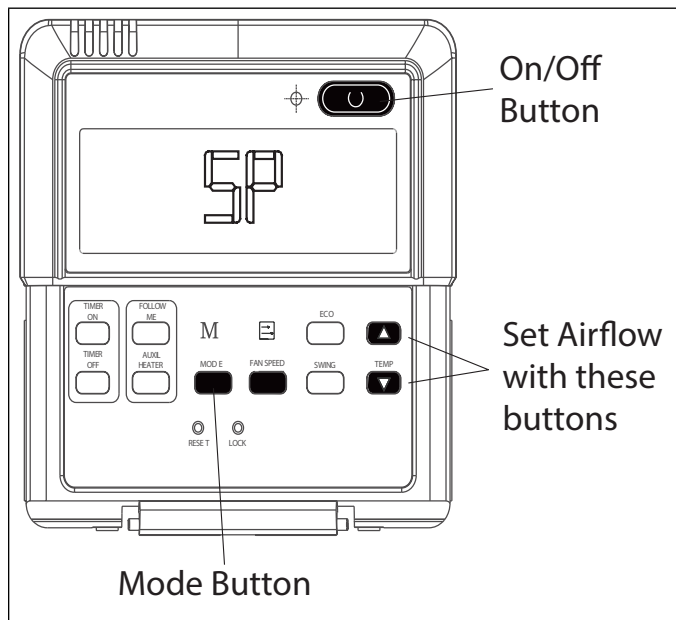

**Figure 41.** M0STAT61Q-1 Wired controller

Refer to the Lennox Product Specification for blower data and settings required for each size unit.

## Troubleshooting

**Table 8. Troubleshooting Codes**

Code	Description
E0	Indoor unit EEPROM error
E1	Communication error between indoor and outdoor units (E2 for outdoor code)
E3	Indoor fan speed error
E4	Indoor return air temperature sensor error
E5	Indoor coil temperature sensor error
EC	Low refrigerant
EE	High water level alarm (for ducted units only)
F0	Outdoor current overload sensed Note: (outdoor unit display --) two dashes
F1	Outdoor ambient temperature sensor error (T4 malfunction) outdoor unit display E4
F2	Outdoor coil temperature sensor error (T3) Malfunction outdoor unit display E4
F3	Compressor discharge temperature sensor error (T5) Malfunction outdoor unit display E4
F4	Outdoor unit EEPROM error - outdoor display E0



**Table 8. Troubleshooting Codes**

Code	Description
F5	Outdoor unit fan speed error - outdoor Error display E8
P0	Inverter module IPM error - outdoor display P6
P1	High or low voltage protection - outdoor display E5
P3	Outdoor unit low temperature lockout - outdoor unit display LP
P4	Compressor drive error
P6	Mode conflict
P7	Compressor high- or low-pressure switch open - outdoor unit display P2

**Test Run**

**Pre-Checks**

Only perform test run after you have completed the following steps:

- Electrical Safety Checks – Confirm that the unit’s electrical system is safe and operating properly.
- Refrigerant Leak Checks – Check all flare nut connections and confirm that the system is not leaking.
- Confirm that liquid and gas valves are fully open.

**Procedure**

You should perform the Test Run for at least 30 minutes.

1. Connect power to the unit.
2. Press the ON/OFF button on the remote controller to turn it on.
3. Press the mode button to scroll through the following functions, one at a time:
  - COOL - Select lowest possible temperature.
  - HEAT - Select highest possible temperature.
4. Let each function run for 5 minutes, and perform the following checks:

**Table 8. Test Run Checklist**

Checks	Pass	Fail
No electrical leakage		
Unit is properly grounded		
All electrical terminals properly covered		
Indoor and outdoor units are solidly installed		
All pipe connection points do not leak		
Water drains properly from drain hose		
All piping is properly insulated		
Unit performs COOL function properly		
Unit performs HEAT function properly		
Indoor unit louvers rotate properly		

**Table 8. Test Run Checklist**

Checks	Pass	Fail
Indoor unit responds to remote controller		

**Dry Mode Operation (Dehumidification)**

**Procedure**

1. Using the provided wired remote control, press the **MODE** button and select **DRY** mode.
2. Press the **UP/ DOWN** button to select the desired temperature. The temperature setting range is from 62°F (17°C) to 86°F (30°C) in one degree increments.

**NOTE:** The blower is preset at a low speed and cannot be changed therefore it will get cold and most likely will surpass the temperature setting and will run down to 50°F (10°C) room temperature depending on the room size or other various factors. Also the **Follow Me** mode does not operate in this mode.

**NOTE:** In addition, the indoor units do not have a humidistat installed therefore they are unable to determine humidity levels. This product is not recommend as a main source for dehumidification.

**Sequence of Operation**

When in dry mode operation the unit is actually in cooling mode with a low speed blower operation. Set remote temp to a lower room temp to begin the dry mode operation. The compressor will stop when the room temperature is 50°F (10°C) lower than the temperature setting. System will not resume unit until room temperature rises above 53.6°F (12°C).