



©2018 Lennox Industries Inc.  
Dallas, Texas, USA

# COMMERCIAL SPLIT SYSTEM KITS AND ACCESSORIES

507812-01  
2/2018

## LOW AMBIENT KIT – VARIABLE

### INSTALLATION INSTRUCTIONS FOR LOW AMBIENT KIT (16X32) USED WITH TSA 120S SERIES UNITS

#### Shipping and Packing List

Package 1 of 1 contains:

- 1 – ICM Controller
- 1 – Pressure transducer
- 1 – Fan power harness
- 1 – Valve depressor w/ two cores
- 1 – Wiring diagram sticker
- 1 – Two-pole relay
- 1 – ICM Controller harness

Wire ties / Self-tapping screws

#### **⚠ WARNING**

Improper installation, adjustment, alteration, service or maintenance can cause property damage, personal injury or loss of life. Installation and service must be performed by a licensed professional HVAC installer or equivalent, service agency, or the gas supplier.

#### **⚠ CAUTION**

As with any mechanical equipment, contact with sharp sheet metal edges can result in personal injury. Take care while handling this equipment and wear gloves and protective clothing.

#### **⚠ WARNING**



Electric Shock Hazard! – Disconnect all power supplies before servicing.  
Replace all parts and panels before operating.  
Failure to do so can result in death or electrical shock.

#### Application

During low ambient conditions, the liquid line pressure will fall. If the pressure gets too low, the system will not have enough pressure drop across it to operate properly. To maintain the head pressure, the low ambient kit, instead of shutting down the condenser fan, slows down the condenser fan until the head pressure rises to the set point. This kit is designed for use in ambient temperatures no lower than 0°F (-17.8°C) unless otherwise noted in the Engineering Handbook.

#### Operation

Liquid line pressure for the TSA units is set at 315 psig. During low ambient conditions, as the liquid line pressure falls, the pressure transducer converts the liquid line pressure to an analog electric signal. The ICM controller then switches the fan motor to variable speed. The condenser fan speed is reduced, thus increasing the liquid line pressure to the set point to ensure unit keeps operating properly.

#### Hardware Installation

- 1 - Disconnect all power to the outdoor unit and open panels on outdoor unit to gain access to the control box.
- 2 - Install the ICM333 variable speed controller at the location shown below using self-tapping screws provided.

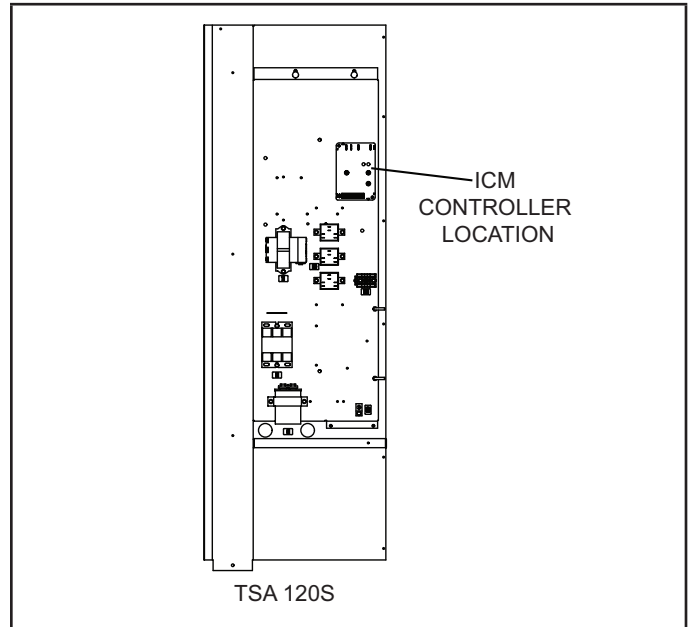
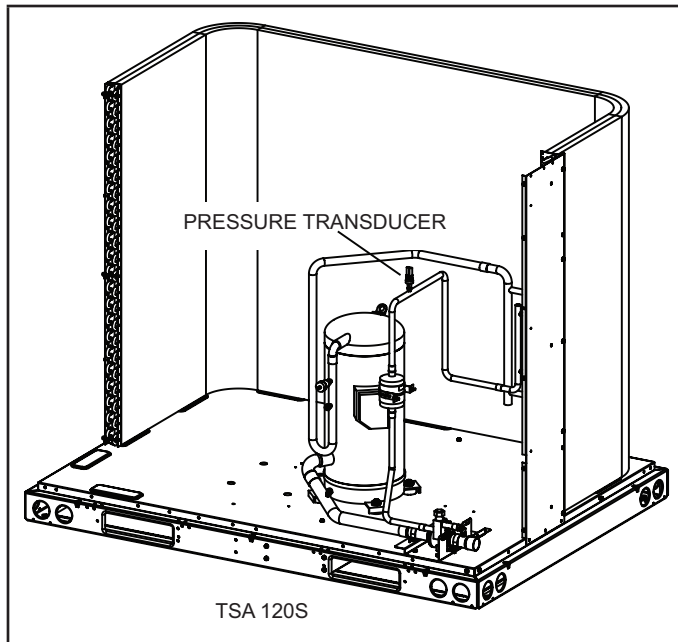

FIGURE 1. ICM Controller Location



- 3 - Set the variable speed controller to the following settings:
  - Setpoint: 315 psig
  - Hard Start: Min.
  - Cut-out Speed: Set to 5th marker from minimum
  - Heat Pump Pin set to: N.O.
- 4 - Disconnect loss of charge switch from the liquid line.
- 5 - If the unit has old low ambient kit installed, remove the pressure switch. Otherwise, install the valve depressor with two cores in place of the loss of charge switch.
- 6 - Connect the loss of charge switch to the valve core of the valve depressor.
- 7 - Install the pressure transducer (ICM380) to the valve core of the valve depressor on the liquid line. Refer to figure 2.



**FIGURE 2. Pressure Transducer Location**

## Electrical Installation

### Connections for ICM333

- 1 - Connect the line power L2 wire to the terminal marked Line 2 on the ICM333 controller.
- 2 - Connect the motor for the outdoor fan to the terminal marked Motor 2 on the ICM 333 controller.
- 3 - Check the voltage to the unit. Depending on the voltage, connect Line Power L1 to the correct terminal marked by Line1/ Motor 1.
- 4 - For voltages between 120 - 277, connect the L1 to the terminal second from the left. For voltages between 480 – 600, connect L1 to the left most terminal on the ICM333 controller.

### Connections for Pressure Transducer

- 1 - Connect the black wire from the pressure transducer to P1 BLK COMM on the controller.
- 2 - Connect the red wire from the pressure transducer to P1 RED on controller.
- 3 - Connect the green wire from the pressure transducer to P1 B, W, G on the controller.

### Remaining Connections

- 1 - Install 24V power harness, A190 controller (ICM33) –A190-24V and A190-COM, to TB14-R and TB14-C.
- 2 - Remove wiring to K10 relay.
- 3 - Remove K10 relay, 56L6801, and replace with relay provided, 67K6501.
- 4 - Remove existing fan power harness and discard it.
- 5 - Install new fan power harness. Connect wire marked K10-5/A190-M in new harness, coming from the ICM Controller, to wire marked K10-5 coming from fan harness. This wire was removed from relay K10 and now to be wired to head pressure control.
- 6 - Make sure all connections are in place.
- 7 - Install wire ties as needed to route all the harnesses.
- 8 - Restore power to the outdoor unit.

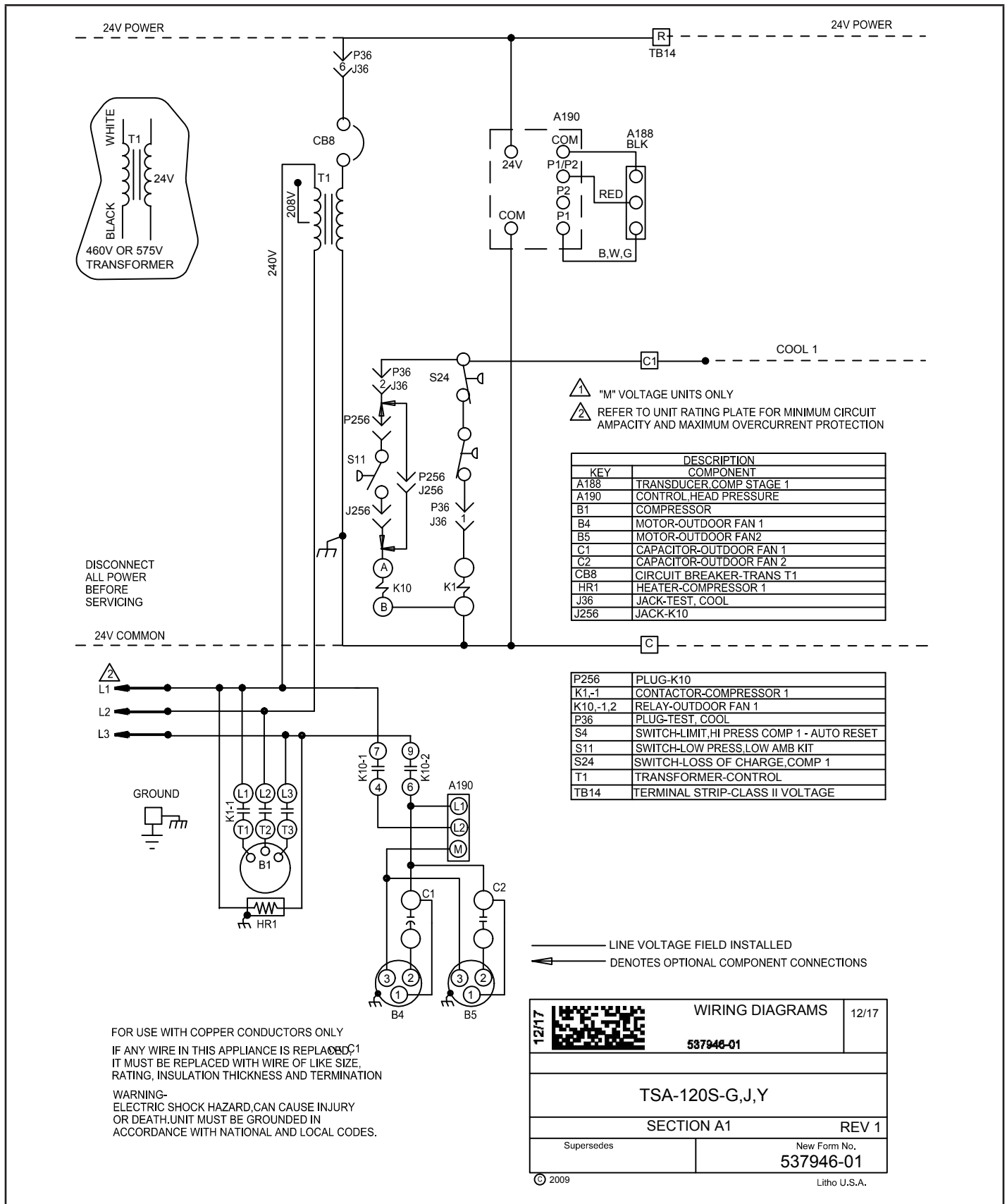

FIGURE 3. Wiring Diagram – TSA 120S