



©2018 Lennox Industries Inc.
Dallas, Texas, USA

COMMERCIAL SPLIT SYSTEM KITS AND ACCESSORIES

507814-01
2/2018

LOW AMBIENT KIT – VARIABLE

INSTALLATION INSTRUCTIONS FOR LOW AMBIENT KIT (16X34) USED WITH TSA 180, 240 SERIES UNITS

Shipping and Packing List

Package 1 of 1 contains:

- 2 – ICM Controller
- 2 – Pressure transducer
- 2 – Fan power harness
- 2 – Valve depressor w/ two cores
- 1 – Wiring diagram sticker
- 2 – Two-pole relay
- 1 – ICM Controller harness

Wire ties / Self-tapping screws

⚠ WARNING

Improper installation, adjustment, alteration, service or maintenance can cause property damage, personal injury or loss of life. Installation and service must be performed by a licensed professional HVAC installer or equivalent, service agency, or the gas supplier.

⚠ CAUTION

As with any mechanical equipment, contact with sharp sheet metal edges can result in personal injury. Take care while handling this equipment and wear gloves and protective clothing.

⚠ WARNING



Electric Shock Hazard! – Disconnect all power supplies before servicing.
Replace all parts and panels before operating.
Failure to do so can result in death or electrical shock.

Application

During low ambient conditions, the liquid line pressure will fall. If the pressure gets too low, the system will not have enough pressure drop across it to operate properly. To maintain the head pressure, the low ambient kit, instead of shutting down the condenser fan, slows down the condenser fan until the head pressure rises to the set point. This kit is designed for use in ambient temperatures no lower than 0°F (-17.8°C) unless otherwise noted in the Engineering Handbook.

Operation

Liquid line pressure for the TSA units is set at 315 psig. During low ambient conditions, as the liquid line pressure falls, the pressure transducer converts the liquid line pressure to an analog electric signal. The ICM controller then switches the fan motor to variable speed. The condenser fan speed is reduced, thus increasing the liquid line pressure to the set point to ensure unit keeps operating properly.

Hardware Installation

- 1 - Disconnect all power to the outdoor unit and open panels on outdoor unit to gain access to the control box.
- 2 - Install the ICM333 variable speed controller at the location shown below using self-tapping screws provided.

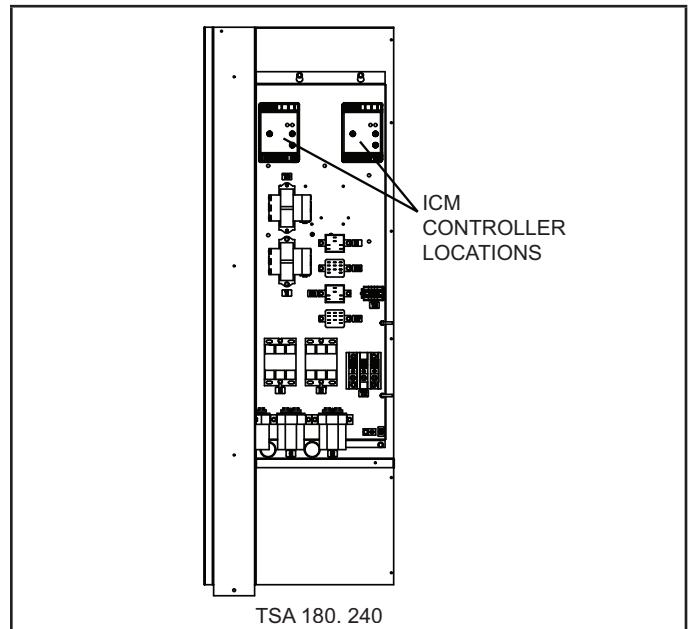

FIGURE 1. ICM Controller Location

- 3 - Set the variable speed controller to the following settings:
 - Setpoint: 315 psig
 - Hard Start: Min.
 - Cut-out Speed: Set to 5th marker from minimum
 - Heat Pump Pin set to: N.O.
- 4 - Disconnect loss of charge switch from the stage 1 liquid line.



- 5 - If the unit has old low ambient kit installed, remove all pressure switches. Otherwise, install the valve depressor with two cores in place of the loss of charge switch.
- 6 - Connect the loss of charge switch to the valve core of the valve depressor.
- 7 - Install the pressure transducer (ICM380) to the valve core of the valve depressor on the stage 1 liquid line. (For TSA 180, refer to figure 2; for TSA 240, refer to figure 3.)

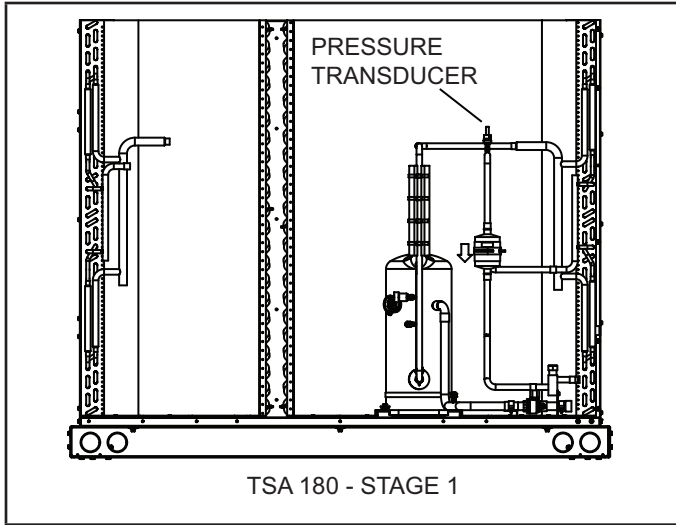

FIGURE 2. Pressure Transducer Location – TSA 180 Stage 1

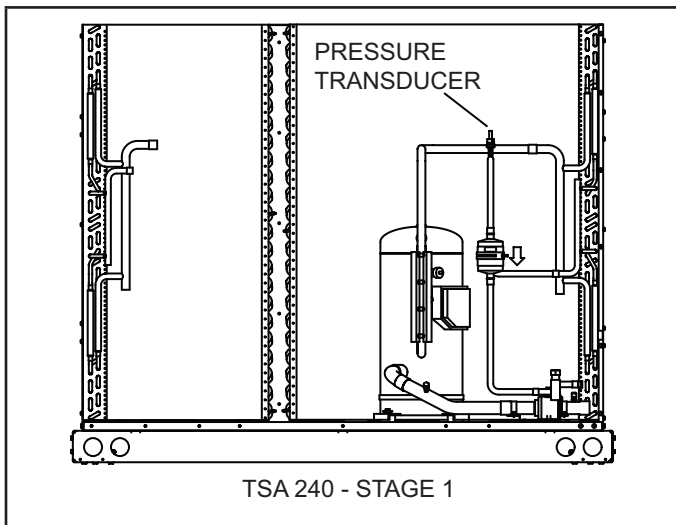

FIGURE 3. Pressure Transducer Location – TSA 240 Stage 1

- 8 - Repeat steps 4 through 7 to install the pressure transducer to the stage 2 liquid line. (For TSA 180, refer to figure 4; for TSA 240, refer to figure 5.)

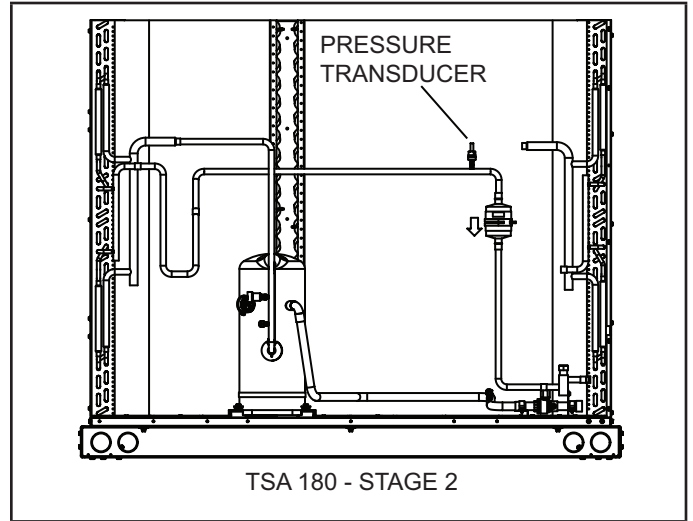

FIGURE 4. Pressure Transducer Location – TSA 180 Stage 2

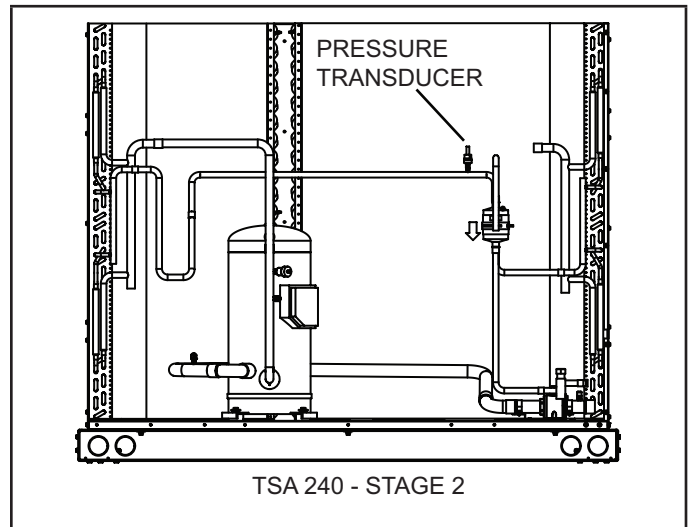

FIGURE 5. Pressure Transducer Location – TSA 240 Stage 2

Electrical Installation

Connections for ICM333 – Stage 1 and 2

- 1 - Connect the line power L2 wire to the terminal marked Line 2 on the ICM333 controller.
- 2 - Connect the motor for the outdoor fan to the terminal marked Motor 2 on the ICM 333 controller.
- 3 - Check the voltage to the unit. Depending on the voltage, connect Line Power L1 to the correct terminal marked by Line1/ Motor 1.
- 4 - For voltages between 120 - 277, connect the L1 to the terminal second from the left. For voltages between 480 – 600, connect L1 to the left most terminal on the ICM333 controller.

Connections for Pressure Transducers

Stage 1:

- 1 - Connect pressure transducer black wires to P1 BLK COMM on the stage 1 controller.
- 2 - Connect pressure transducer red wires to P1 RED on the stage 1 controller
- 3 - Connect pressure transducer green wire to P1, B, W, G on the stage 1 controller

Stage 2:

- 1 - Connect pressure transducer black wires to P1 BLK COMM on the stage 2 controller.
- 2 - Connect pressure transducer red wires to P1 RED on the stage 2 controller
- 3 - Connect pressure transducer green wire to P1, B, W, G on the stage 2 controller

Remaining Connections

Stage 1

- 1 - Install 24V power harness, A190 controller (ICM33) –A190-24V and A190-COM, to TB14-R and TB14-C.
- 2 - Remove wiring to K10 relay.
- 3 - Remove K10 relay, 56L6801, and replace with one of the relays provided, 67K6501.
- 4 - Remove existing fan power harness and discard it.
- 5 - Install new fan power harness. Connect wire marked K10-5/A190-M in new harness, coming from the ICM Controller, to wire marked K10-5 coming from fan harness. This wire was removed from relay K10 and now to be wired to head pressure control.

Stage 2

- 1 - Install 24V power harness, A193 controller (ICM33) –A193-24V and A193-COM, to TB14-R and TB14-C.
- 2 - Remove wiring to K149 relay.
- 3 - Remove K149 relay, 56L6801, and replace with one of the relays provided, 67K6501.
- 4 - Remove existing fan power harness and discard it.
- 5 - Install new fan power harness. Connect wire marked K149-5/A193-M in new harness, coming from the ICM Controller, to wire marked K149-5 coming from fan harness. This wire was removed from relay K149 and now to be wired to head pressure control.
- 6 - Make sure all the connections are in place.
- 7 - Install wire ties as needed to route all the harnesses.
- 8 - Restore power to the outdoor unit.

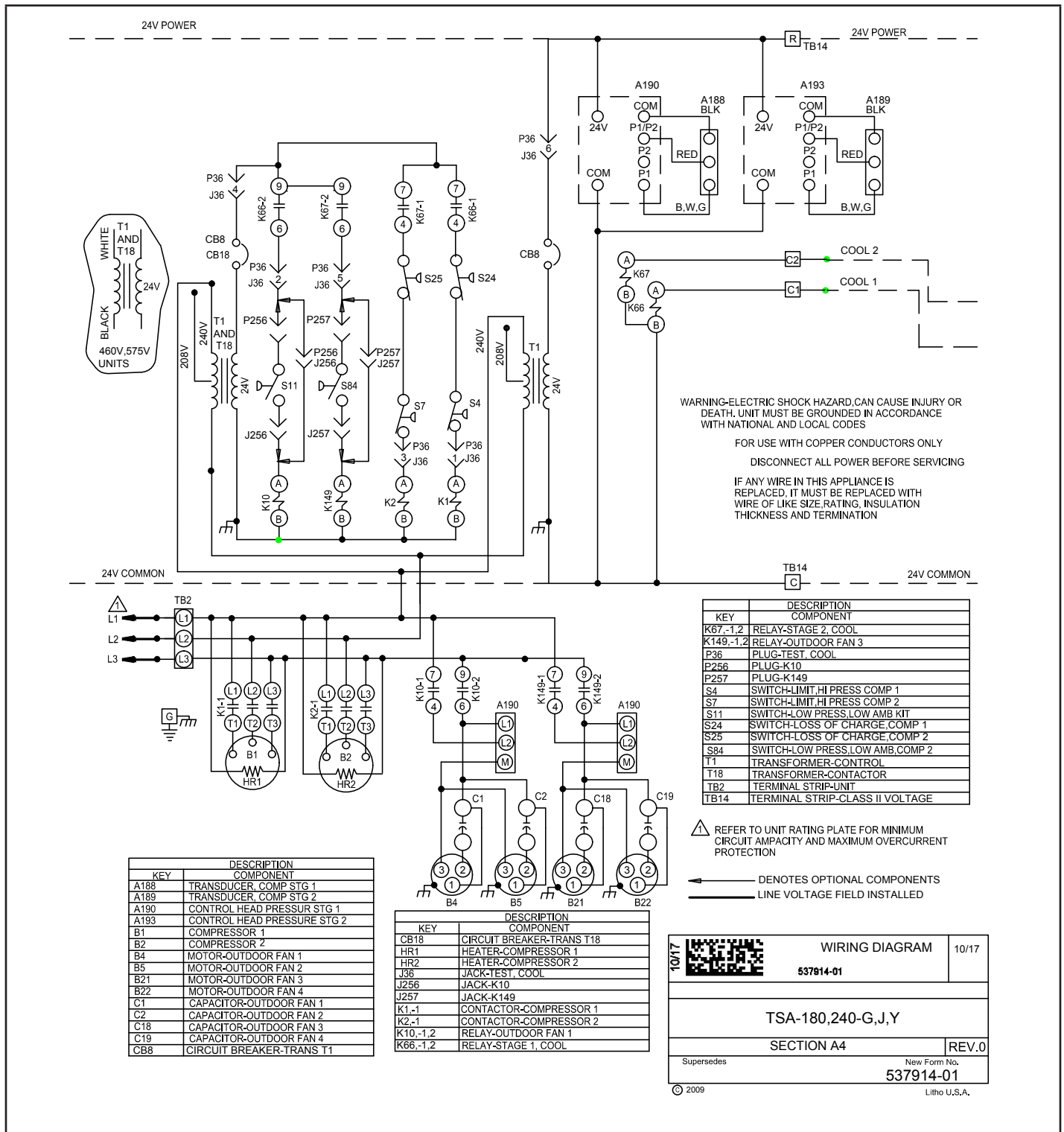

FIGURE 6. Wiring Diagram – TSA 180, 240