

# KITS COMMON TO OUTDOOR COOLING UNITS

507841-01  
04/2018

## INVERTER REPLACEMENT KIT

### INSTALLATION INSTRUCTIONS FOR INVERTER REPLACEMENT KITS (16Y25, 16Y26) USED WITH XC25 / XP25 4- AND 5-TON UNITS

#### Shipping and Packing List

Package 1 of 1 contains:

- 1 – Replacement inverter
- 1 – Replacement reactor
- 4 – Self-tapping screws

Check package for shipping damage. Contact the last carrier immediately if any shipping damage is found.

#### **⚠ WARNING**

Improper installation, adjustment, alteration, service or maintenance can cause property damage, personal injury or loss of life. Installation and service must be performed by a licensed professional HVAC installer or equivalent, service agency, or the gas supplier.

#### **⚠ CAUTION**

As with any mechanical equipment, contact with sharp sheet metal edges can result in personal injury. Take care while handling this equipment and wear gloves and protective clothing.

#### **⚠ WARNING**



Electric Shock Hazard! – Disconnect all power supplies before servicing.  
Replace all parts and panels before operating.  
Failure to do so can result in death or electrical shock.

#### Procedure

- 1 - Disconnect all power to unit.
- 2 - Remove screws securing control panel access panel.
- 3 - Disconnect wiring connected to existing inverter board:
  - Blue plug from noise filter
  - 3-wire compressor plug
  - Communication wire to MUC control board
  - Blue and brown plugs from reactor

- 4 - Disconnect blue and brown wires with fork connection at contactor. (**NOTE** – Loosen screws on contactor until fork connectors can be disconnected. Do not remove screws completely.)
- 5 - Disconnect blue and brown wires with fork connection from reactor to noise filter. (**NOTE** – Loosen screws on noise filter until fork connectors can be disconnected. Do not remove screws completely.) Refer to figure 1.



FIGURE 1

- 6 - Remove six screws securing existing inverter board and remove it. Retain the screws.
- 7 - Remove four screws securing the existing reactor and remove it. Retain the screws.
- 8 - Remove four screws securing the existing noise filter and remove it. Retain the screws. Noise filter will not be reinstalled.

- 9 - Orient the new inverter board so that the five large capacitors are at the bottom of the board.
- 10 - Install the new inverter in the control panel, positioned just above the heat sink and flat against the back of the control panel. Use the six screws removed in step 6.
- 11 - Orient the new reactor with the wires facing down and install starting with the existing hole shown in figure 2. Use provided self-tapping screws in the remaining 3 mount holes.

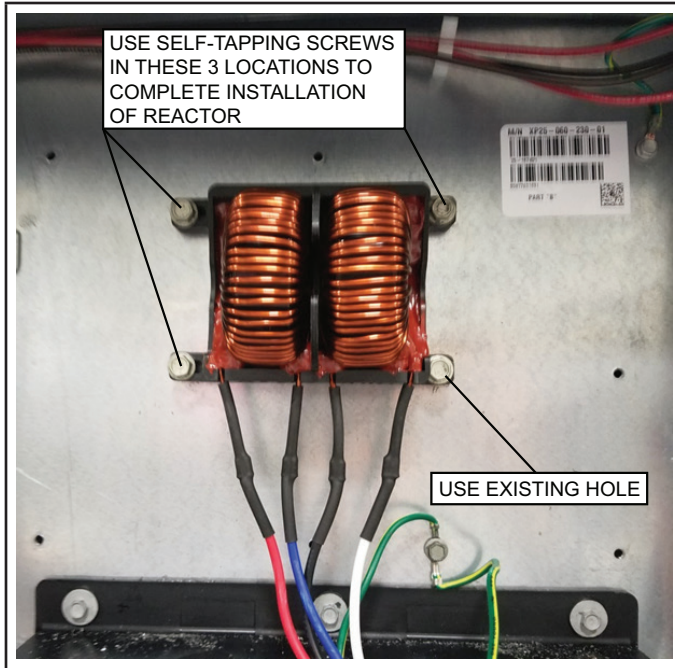

**FIGURE 2**

- 12 - Reconnect all inverter board wiring:
  - Red and blue plugs from reactor
  - 3-wire compressor plug
  - Communication wire to MUC control board
  - Two ground wires. Use two open hole locations.
  - Blue and brown wires with fork connection at contactor. Brown on left, blue on right. Refer to figure 3.



**FIGURE 3**

- 13 - Fill all remaining holes with unused screws, a total of five.
- 14 - Reinstall sheet metal barrier plate.
- 15 - Reinstall control panel access panel.
- 16 - Restore power to the unit.