



VRF

©2019 Lennox Industries Inc. Dallas, Texas, USA



THIS MANUAL MUST BE LEFT WITH THE OWNER FOR FUTURE REFERENCE

These instructions are intended as a general guide and do not supersede local codes in any way. Consult authorities having jurisdiction before installation.

! WARNING

Improper installation, adjustment, alteration, service or maintenance can cause property damage, personal injury or loss of life.

Installation and service must be performed by a licensed professional HVAC installer, service agency or the gas supplier.

Failure to follow safety warnings and these instructions exactly could result in property damage, dangerous operation, serious injury, or death.

Any additions, changes, or conversions required in order for the appliance to satisfactorily meet the application needs must be made by a licensed professional HVAC installer (or equivalent) using factory-specified parts.

Do not use this system if any part has been under water. A flood-damaged appliance is extremely dangerous. Immediately call a licensed professional HVAC service technician (or equivalent) to inspect the system and to replace all controls and electrical parts that have been wet, or to replace the system, if deemed necessary.

! CAUTION

As with any mechanical equipment, contact with sharp sheet metal edges can result in personal injury. Take care while handling this equipment and wear gloves and protective clothing.

To ensure proper system performance and reliability, Lennox does not recommend operation of VRF systems during any phase of construction. Construction debris, low temperatures, harmful vapors, and operation of the unit with misplaced filters can damage the units. Failure to follow these guidelines will result in the warranty being voided.

INSTALLATION INSTRUCTION

VMDB Medium-Static Units

VRF SYSTEMS -- Indoor Units
507893-02
07/2019

! IMPORTANT

The Clean Air Act of 1990 bans the intentional venting of refrigerant (CFCs, HCFCs and HFCs) as of July 1, 1992. Approved methods of recovery, recycling or reclaiming must be followed. Fines and/or incarceration may be levied for noncompliance. These units must be installed as a part of a matched system as specified in the Product Specifications (EHB) bulletin.

General

The VMDB medium-static ducted indoor units are matched with an outdoor heat recovery or heat pump unit to create a VRF (variable refrigerant flow) system that uses R-410A refrigerant. VMDB indoor units are designed for indoor installation only.

Refer to the Product Specification bulletin (EHB) for the proper use of these indoor units with specific heat pumps, heat recovery units, mode switching devices, branch pipes, line sets and controls.

These instructions are intended as a general guide and do not supersede local or national codes in any way. Authorities having jurisdiction should be consulted before installation.

Shipping and Packing List

Check the components for shipping damage. If you find any damage, immediately contact the last carrier.

Package 1 of 1 contains the following:

- 1 - Assembled medium static, ducted unit
- 2 - Condensate drain insulation sleeves
 - 1 - Flexible condensate connector
 - 1 - Hose clamp
- 2 - Pipe reducers (VMD007, 009, 012 & 015)
- 1 - Resistor
- 1 - Cable
- 1 - Installation manual

Safety Requirements

⚠ WARNING

ELECTRICAL SHOCK, FIRE, OR EXPLOSION HAZARD.

Do not touch the unit or the controller if your hands are wet.

DO NOT spray water on the indoor unit for any reason.

Do not replace a fuse with a fuse of a different rating. Do not use a jumper wire to replace a fuse. Do not insert your hands, tools or any other item into the air intake or air outlet at either the indoor or outdoor unit.

Do not allow children to operate the system.

Model Number Identification

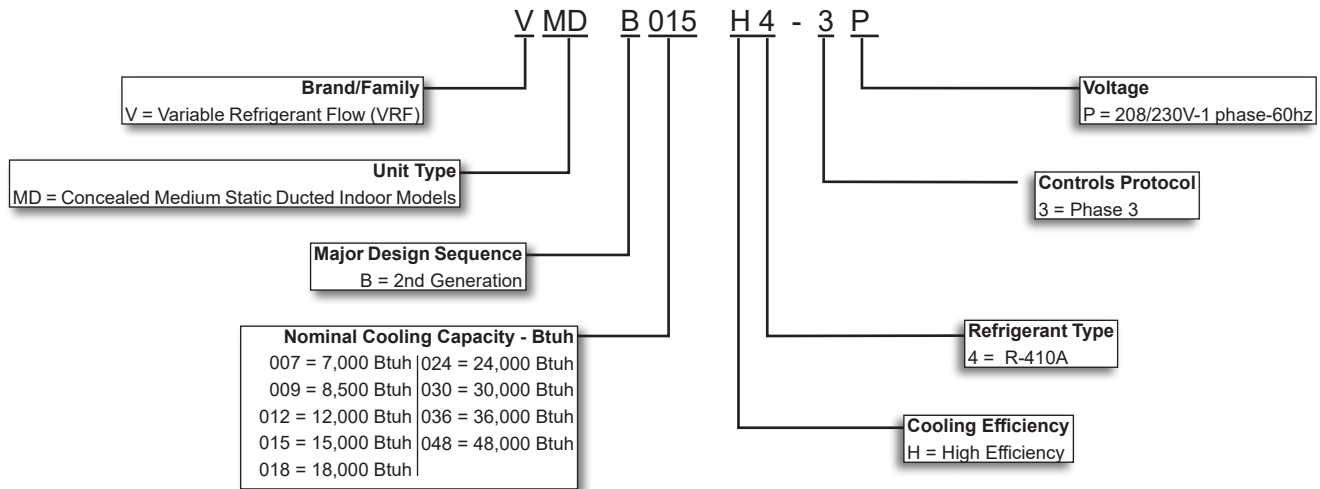

NOTE - Only Lennox VRF indoor units will work with Lennox VRF outdoor units and associated mechanical equipment. Lennox Mini Split indoor units are similar in appearance but must not be connected to a Lennox VRF refrigerant circuit. Please refer to model numbers to confirm compatibility. Model numbers for Lennox VRF units start with a "V" and model numbers for Lennox Mini-Splits start with a "M".

System Piping

⚠ CAUTION

VRF system piping is customized for each installation. The LVSS (Lennox VRF Selection Software) piping report is an engineered design that must be followed. The piping diagram or diagrams included within the LVSS report have been prepared based on the information provided to the Lennox VRF applications department.

When the indicated lengths change from the figures stated within the report, it is imperative that prior to the commencement of the refrigerant pipe work installation, Lennox VRF applications department are informed of these proposed changes.

Upon receipt of this new information the Lennox VRF applications department will confirm any changes that may be applicable to this installation. If changes are required, a new piping diagram will be produced and will supersede all other previously provided documents.

Failure to provide this information regarding changes to the original design may lead to insufficient capacity, equipment failure, warranty being made void and the refusal to commission the system.

VMDB007-009 Unit Dimensions

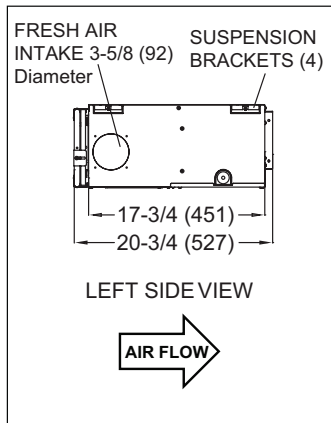
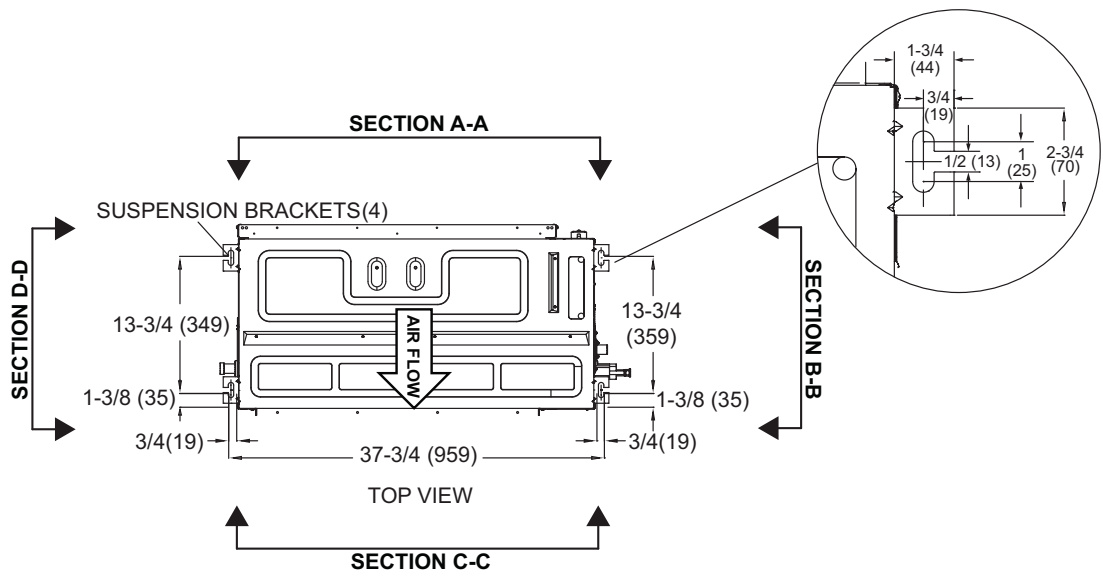

SECTION D-D

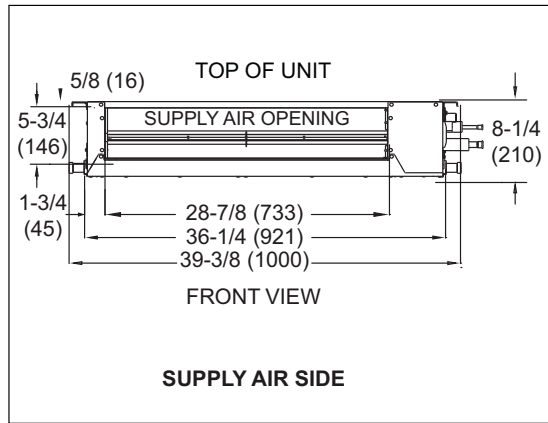

SECTION C-C

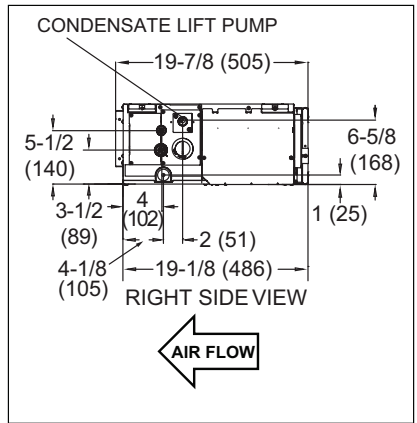

SECTION B-B

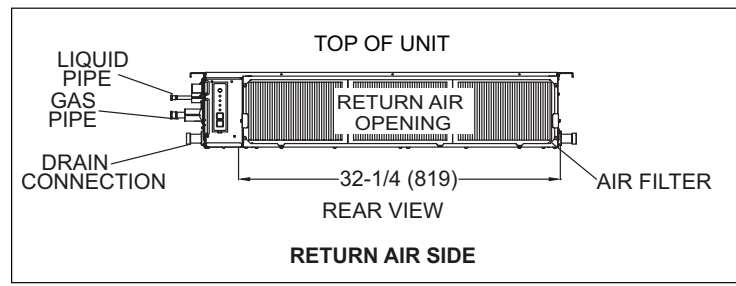

SECTION A-A

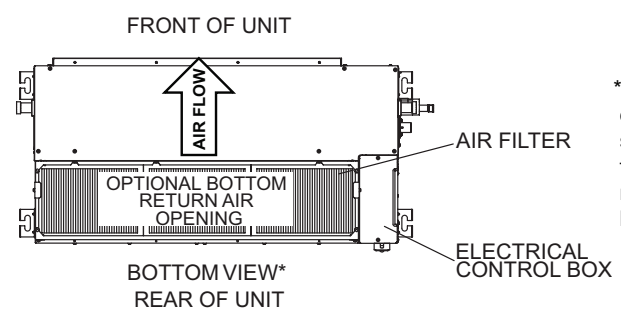

*NOTE - Unit orientation reversed to show alternative filter location and return air path on bottom of unit.

VMDB012-048 Unit Dimensions

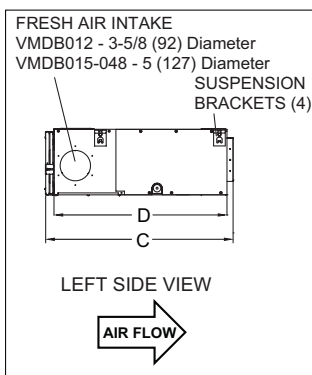
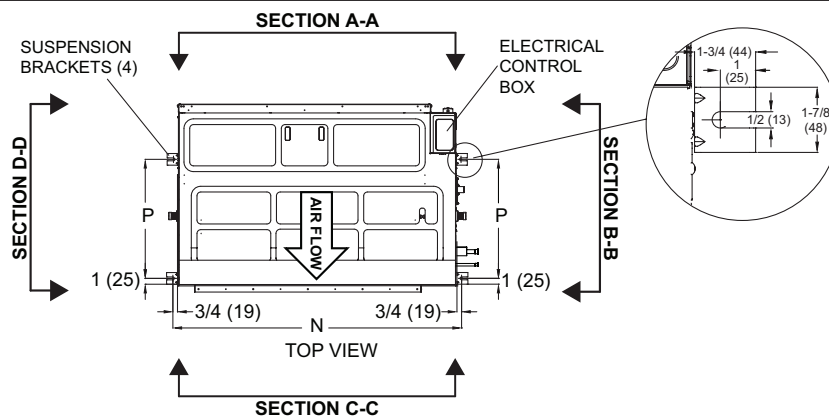

SECTION D-D

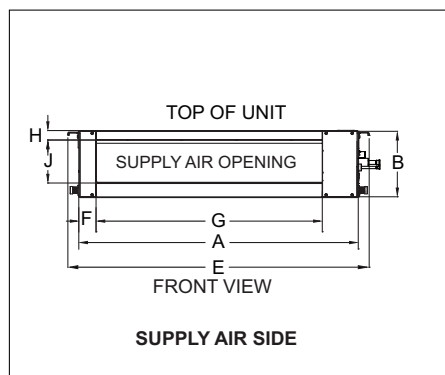

SECTION C-C

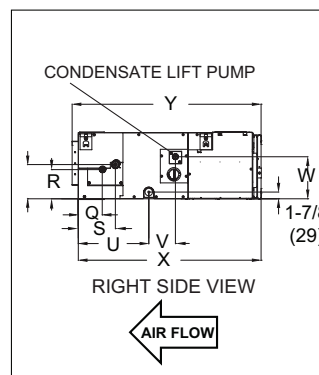

SECTION B-B

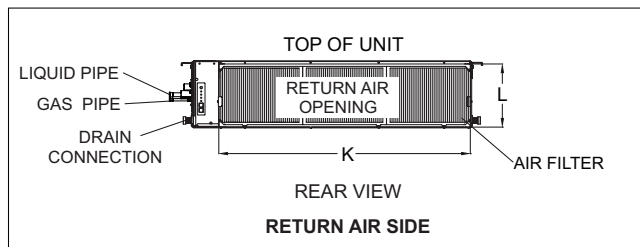

SECTION A-A

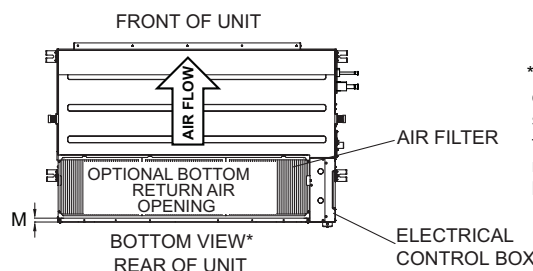

*NOTE - Unit orientation reversed to show alternative filter location and return air path on bottom of unit.

Size	A		B		C		D		E		F		G		H		J	
	in.	mm	in.	mm	in.	mm	in.	mm	in.	mm	in.	mm	in.	mm	in.	mm	in.	mm
012	36-1/4	921	10-5/8	270	25-3/8	645	22-1/2	572	39-3/4	1010	2-5/8	67	28	711	1-3/8	35	7	178
015/018/024	44-7/8	1140	10-5/8	270	30-1/2	775	28	711	48-1/2	1232	2-5/8	67	36-3/4	933	1-3/8	35	7	178
030/036/048	47-1/4	1200	11-7/8	302	34-1/8	867	31-1/2	800	50-3/4	1289	3-1/8	79	38-1/8	968	1-1/2	38	8	203

Size	K		L		M		N		P		Q		R		S		T		U	
	in.	mm	in.	mm	in.	mm	in.	mm	in.	mm	in.	mm	in.	mm	in.	mm	in.	mm	in.	mm
012	32	813	10-1/4	260	---	---	37-3/4	961	13-3/4	349	3-7/8	99	4-5/8	117	6	152	5-5/8	143	8-1/8	206
015/018/024	40-3/4	1035	10-1/4	260	3/4	18	46-3/4	1188	19-1/4	490	3-7/8	99	4-5/8	117	6	152	5-1/2	140	11-3/8	289
030/036/048	43	1092	11-3/8	289	2	48	49	1246	19-3/4	502	6-3/8	162	6-7/8	175	8-3/8	213	7-5/8	194	9-3/4	248

Size	V		W		X		Y	
	in.	mm	in.	mm	in.	mm	in.	mm
012	1-7/8	48	6-3/4	171	24-1/8	613	25-1/8	638
015/018/024	4-1/4	108	6-3/4	171	29-3/8	746	30-1/4	768
030/036/048	7-1/4	184	6-3/4	171	33-1/8	841	34	864

Clearances

Refer to Figure 1 for minimum clearance requirements.

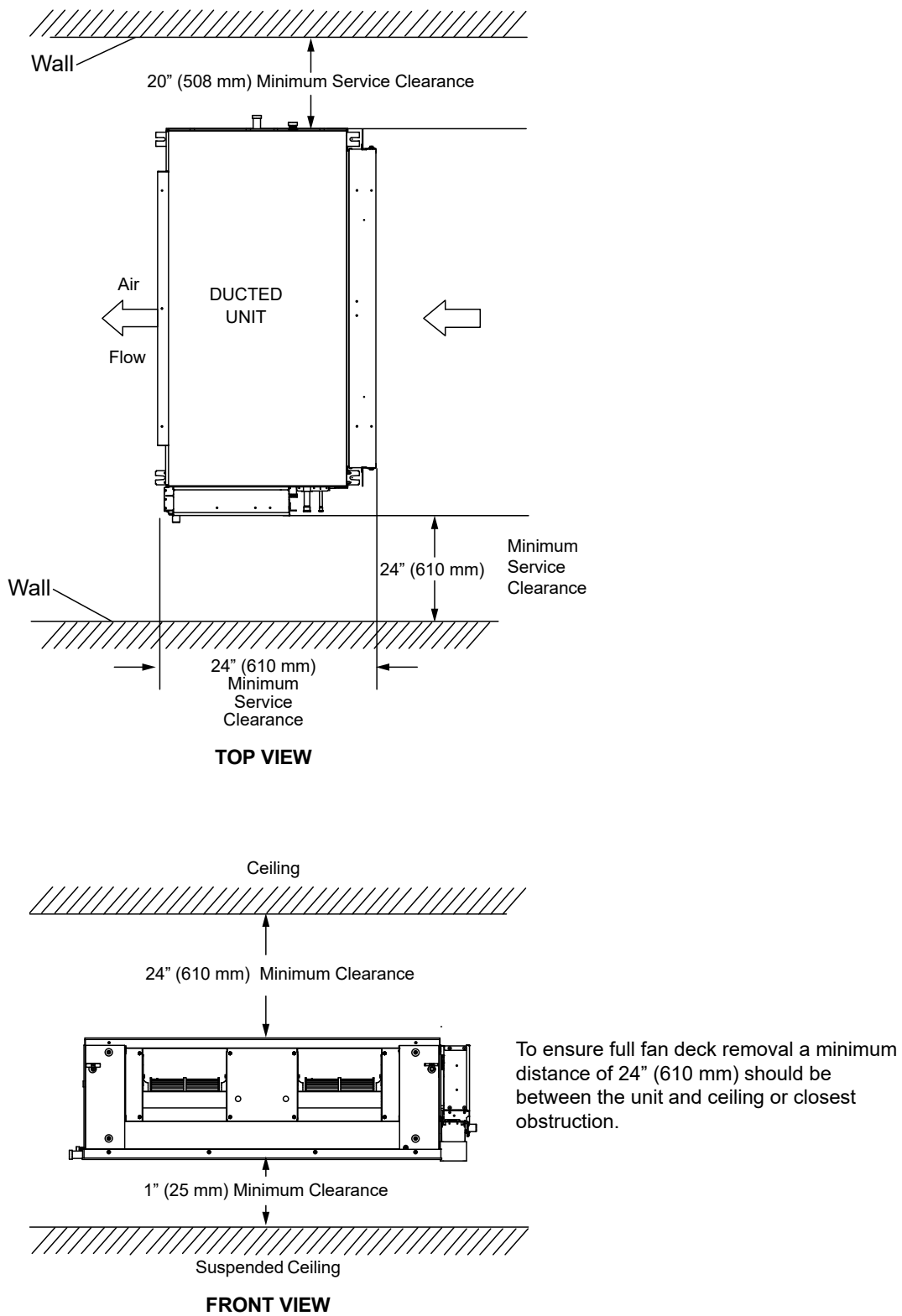

NOTE - No part of the suspended ceiling, or other supports not directly associated with the indoor unit installation, can be fixed to, or touch the indoor unit, in any form. Minimum clearances must be observed at all times.

NOTE - Horizontal installation only.

Figure 1. Minimum Installation Clearances

Unit Placement

In addition to clearances, the following items should be considered:

WARNING

Use the provided and specified components when installing equipment. Failure to do so may result in unit falling, water leaking or electrical shocks, causing personal injury or equipment or property damage.

Check suitability of structure to which the unit support mechanism will be fixed to. If structure is not capable of carrying the weight of the unit, unit may fall causing personal injury or equipment damage.

Consider the possibility of earthquakes in your area when installing the equipment. If the unit is not correctly secured, it may fall, causing personal injury or equipment damage.

Safely dispose of packing materials, which include nails, wood and other sharp objects, as well as plastic wrapping. Children playing with plastic wrap or bags risk the danger of suffocation.

Remove tape from Receiver (rear of electrical control box) prior to commissioning

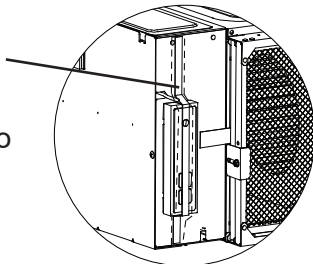

CAUTION

Do not place items which may be damaged by water under or around the unit.

The unit should be installed at least 8 feet above the floor (if possible) to ensure maximum performance and comfort.

Unit Installation

Unit Installation Guidelines

- Install a field-provided isolation grommet as shown in Figure 4 to prevent transmission of vibration from unit to structural ceiling.
- Provide separate support for the weight of the duct system. Duct system must not be supported by the indoor unit.
- It is recommended that you use flexible joints (canvas) at the point where the duct connects to the unit on both ends. Material must meet all local and national code requirements.

AVOID

Do not install the unit in the following locations:

- Areas exposed to petrochemicals or petrochemical products
- Areas exposed to salt or other corrosive materials or caustic gasses
- Areas exposed to extreme voltage variations (such as factories)
- Tightly enclosed areas that may impede service of the unit
- Areas exposed to fossil fuels (such as oil or gas in kitchens)
- Areas exposed to strong electromagnetic forces
- Areas exposed to acids or alkaline detergents (laundry rooms)

DO:

- Locate the unit so that it is not exposed to direct sunlight
- Ensure the structural ceiling can support the weight of the unit.
- Select a location where condensate line will have the shortest run to a suitable drain per local codes.
- Allow sufficient space around unit for proper operation and maintenance
- Install unit a minimum of 3 feet (1 meter) away from any antenna, power cord (line) radio, telephone, security system, or intercom. Electrical interference and radio frequencies from any of these sources may affect operation
- Be sure to instruct customers how to properly operate the unit (especially maintenance of air filter, and operation procedure) by having them carry out operations themselves while looking at the manual provided with the equipment.

- When unit is being installed in a location where even the slightest noise would be a problem (meeting room or other very quiet space), design duct system to avoid transmission of vibration to the structure to the extent possible.
- For Ducted return systems, a minimum surface area of 200 sq. in. per ton is recommended.
Example: 3 Ton IDU.
3 tons x 200 sq. in. per ton = 600 sq. in.

Unit Installation Instructions

1. Make sure that the structural ceiling or slab is able to support the weight of the indoor unit. It may be necessary to add extra support.
2. Install suspension rods in the structural ceiling or concrete slab in a suitable location. If the structural ceiling is constructed of concrete, install anchors to accept four $\frac{3}{8}$ " threaded rods to suspend the indoor unit. If the structural ceiling includes wooden joists, use angle iron or Unistrut channel fixed securely in place to accept the $\frac{3}{8}$ " threaded rods. **NOTE - Threaded rod (requirement of Lennox warranty program) is the ONLY acceptable method of suspending the unit; do not use chains or straps.** See Figure 2.

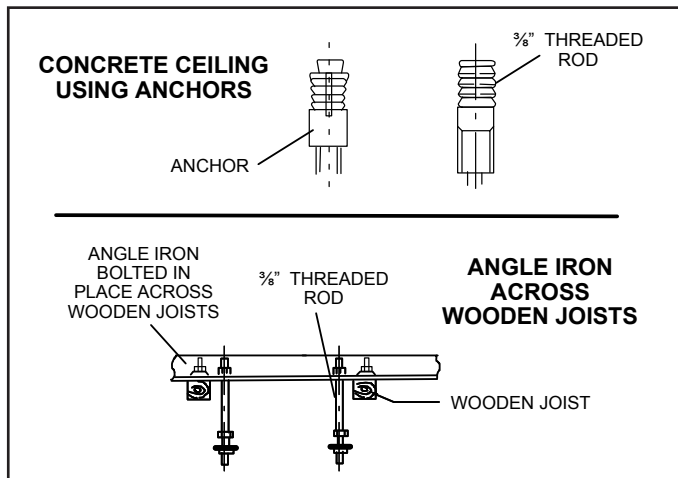

Figure 2. Suspending Methods

3. Slide one nut and one washer onto each threaded rod. Use electrical tape to keep the washer from falling off. Position the nuts slightly above the final resting place of the four suspension brackets. See Figure 3.

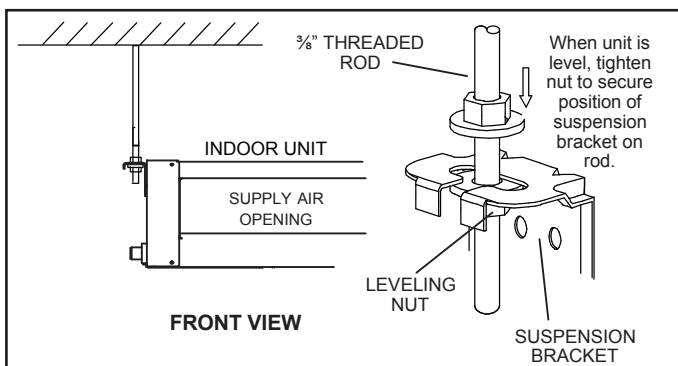

Figure 3. Suspension Hardware

4. Use either a mechanical lifting device or a minimum of two people to raise the unit and insert the threaded rods into the suspension brackets on the cassette base. Slide a washer and then a nut onto each rod below each suspension bracket. Use the leveling nut (beneath suspension bracket) to adjust the unit to the correct height. Remove the electrical tape holding the upper washers and nuts in place and tighten each of the four nuts above the brackets down onto the brackets. This will ensure that the unit remains level.
5. It is recommended to install a field-provided isolation grommet as shown in Figure 4 to prevent transmission of vibration from unit to structural ceiling.

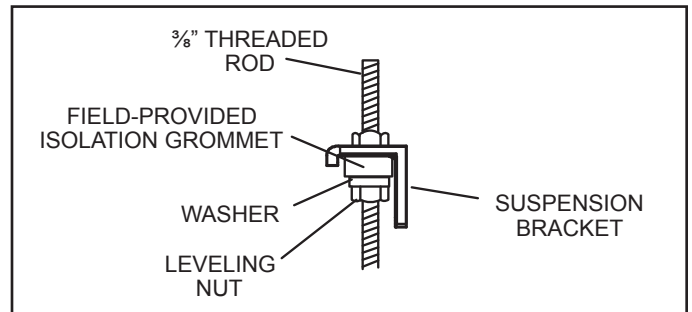

Figure 4. Isolation Grommet

6. If the unit is being installed in an application that includes a sheet rock (plasterboard) ceiling, it is required that an access panel be installed in a suitable location. This will also allow access for future maintenance (requirement of Lennox warranty program). Access is required during the commissioning process to test the condensate disposal system (See Figure 20) and to check the local disconnect.
7. The unit is factory-configured for the supply air to be delivered from the front and the return air filter at the rear of the unit. The return air filter location can be relocated in the field for bottom return air filter access, if more convenient. See Figure 10.

Return Air Filter

Foldable Return Air Filter

The factory-supplied return air filter is hinged to allow it to be folded if needed to remove it from the unit in tight spaces. See Table 1 for filter dimensions.

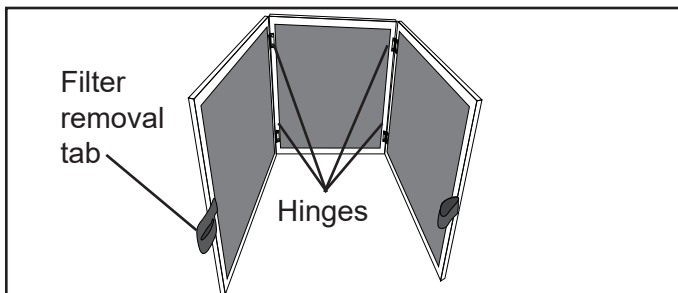

Figure 5. Foldable Factory-Supplied Return Air Filter

Remove Return Air Filter Instructions

1. If removing the filter from the left side (facing the rear of the unit), remove the factory-installed receiver from the electrical control box panel by sliding the receiver up until the two plastic mounting brackets on the back of the receiver slide out of the slots on the back of the control box. This step is not necessary if removing the filter from the right side (facing the rear of the unit).

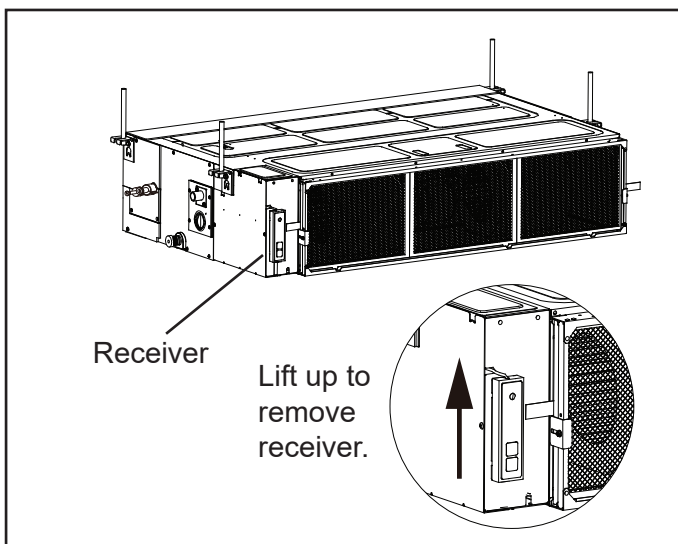

Figure 6. Remove Receiver

2. Loosen the screw that secures the filter retaining bracket and slide the bracket away from the unit.

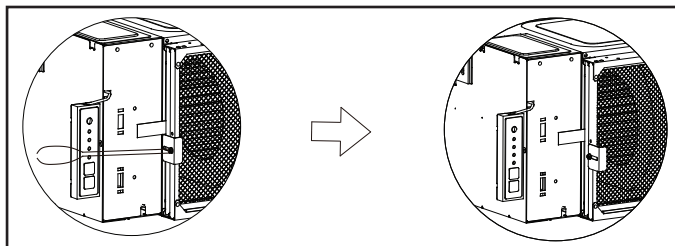

Figure 7. Loosen Filter Retaining Bracket

3. Grasp the filter removal tab and slide the filter out.

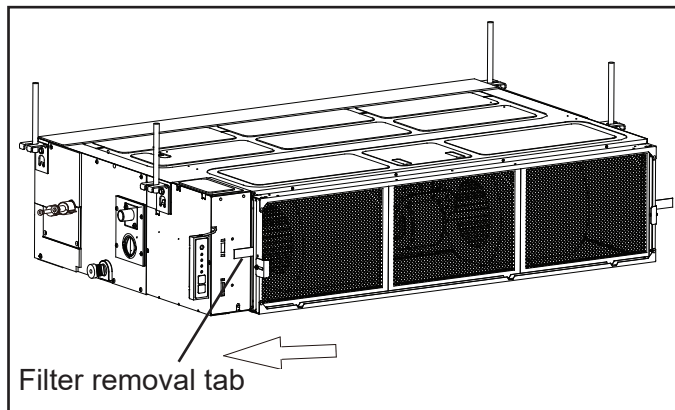

Figure 8. Slide Out Filter

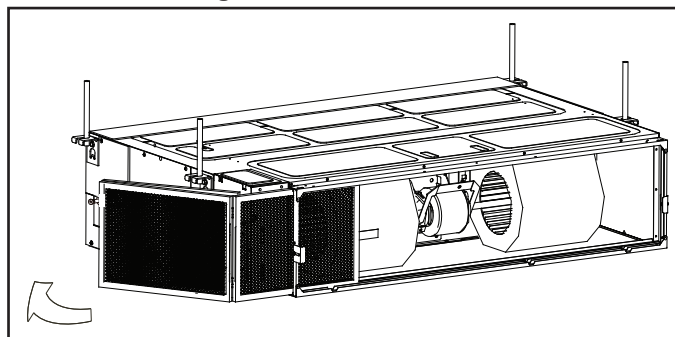

Figure 9. Filter Partially Removed

4. Reverse these steps to reinstall the filter. Be sure to reinstall the receiver if it was detached during the filter removal.

Table 1. Filter Dimensions

Indoor Unit Model	Filter Dimensions	Each Section of Filter Dimensions
VMDB007,009	32 x 7-1/2 x 3/8 in. 813 x 192 x 10 mm	8-1/2 x 7-1/2 x 3/8 in. 217 x 192 x 10 mm
VMDB012	32 x 10 x 3/8 in. 813 x 252 x 10 mm	8-1/2 x 7-1/2 x 3/8 in. 217 x 252 x 10 mm
VMDB015,018,024	40-3/4 x 10 x 3/8 in. 1035 x 252 x 10 mm	13-1/2 x 7-1/2 x 3/8 in. 345 x 252 x 10 mm
VMDB030,036,048	43-1/8 x 11 x 3/8 in. 1095 x 278 x 10 mm	14-3/8 x 11 x 3/8 in. 365 x 278 x 10 mm

Relocate Return Air Filter Instructions

1. Remove the return air filter from its existing location at the rear of the unit.
2. Remove the screws that secure the filter frame to the rear of the unit and set the frame aside. See Figure 10.
3. Remove the screws that secure the return air cover plate to the bottom of the unit. Set the cover plate aside. See Figure 10.

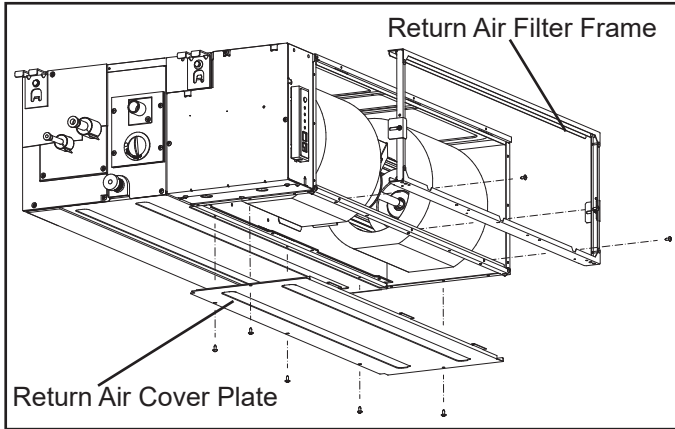

Figure 10. Remove Filter, Filter Frame and Return Air Cover Plate from Existing Location

4. Apply field-supplied foam insulating tape to the return air opening on the bottom of the unit. See Figure 11.

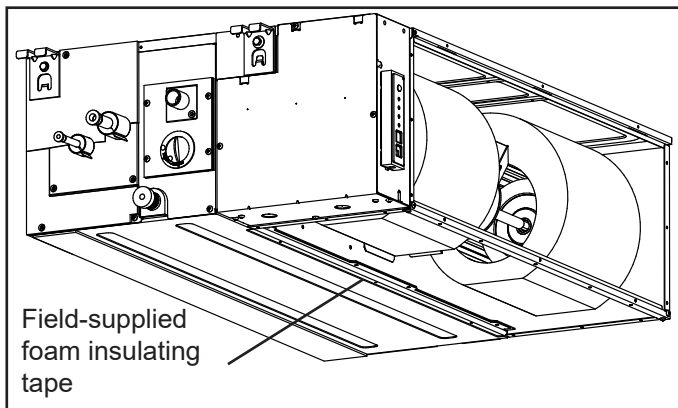

Figure 11. Apply Foam Insulating Tape

5. Use the existing screws to re-install the return air filter frame on the bottom of the unit. See Figure 12.
6. Use the existing screws to re-install the return air cover plate on the rear of the unit. See Figure 14.

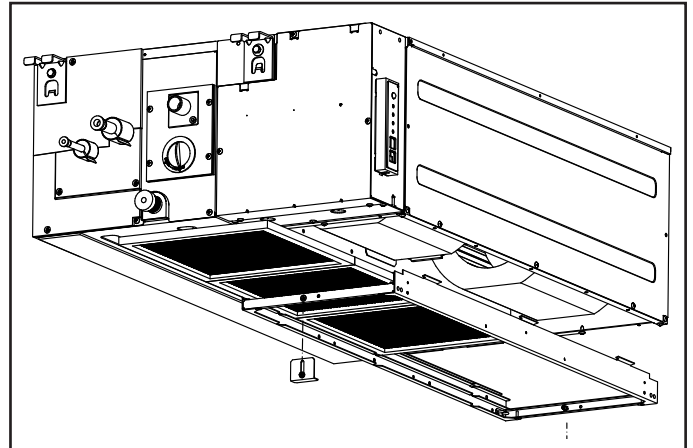

Figure 12. Re-install Filter Frame and Return Air Cover Plate

7. Re-install the return air filter in the repositioned filter frame in the bottom of the unit. Use the provided clips to secure the filter within the filter frame as shown in Figure 13.

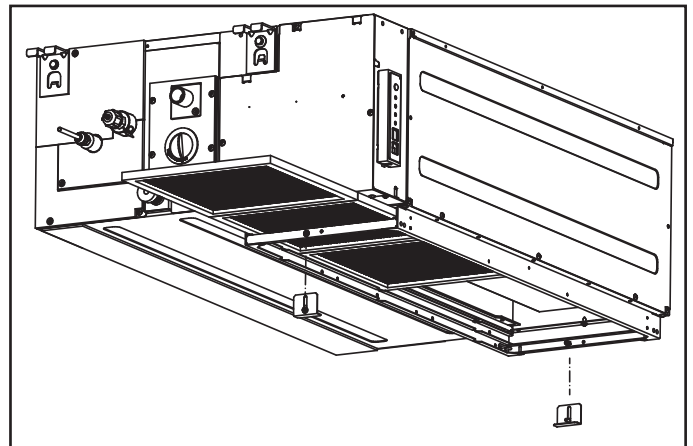

Figure 13. Re-install Filter using Clips

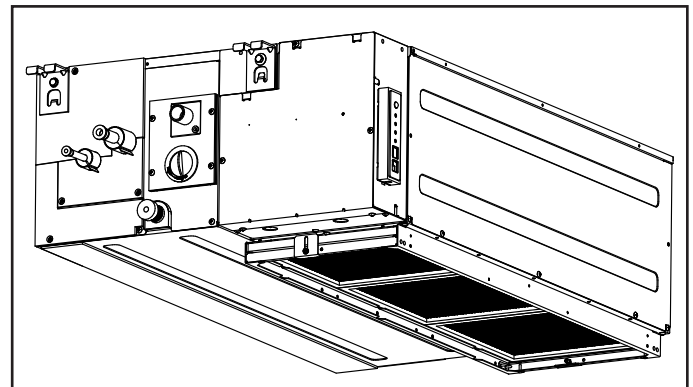

Figure 14. Relocate Return Air Filter Complete

Refrigerant Piping Connections

WARNING

Refrigerant leaks are unlikely; however, if a refrigerant leak occurs, open a door or windows to dilute the refrigerant in the room. Turn off the unit and all other appliances that may cause a spark. Call a licensed professional HVAC technician (or equivalent) to repair the leak.

Use only R410A refrigerant to charge this system. Use of other refrigerant or gas will damage the equipment. Do not allow air or other contaminants to enter system during installation of refrigerant piping. Contaminants will result in lower system capacity and abnormally high operating pressures and may result in system failure or explosion.

Insulate all refrigerant piping.

Refrigerant pipes may be very hot during unit operation. Do not allow contact between wiring and bare copper pipes.

After refrigerant piping connections have been completed, check the system for leaks per commissioning instructions.

WARNING



Danger of fire. Bleeding the refrigerant charge from only the high side may result in pressurization of the low side shell and suction tubing. Application of a brazing torch to a pressurized system may result in ignition of the refrigerant and oil mixture. Check the high and low pressures before applying heat.

CAUTION

Brazing alloys and flux contain materials which are hazardous to your health.

Avoid breathing vapors or fumes from brazing operations. Perform operations only in well-ventilated areas.

Wear gloves and protective goggles or face shield to protect against burns.

Wash hands with soap and water after handling brazing alloys and flux.

CAUTION

Purge low pressure nitrogen [1 to 2 psig (6.0 to 12.8 kPA)] through the refrigerant piping during brazing. This will help to prevent oxidation and the introduction of moisture into a system.

To prevent the build-up of high levels of nitrogen when purging be sure it is done in a well ventilated area.

IMPORTANT

Refrigerant lines must be clean, dry, refrigerant-grade copper lines. Air handler coils should be installed only with specified line sizes for approved system combinations.

Handle refrigerant lines gently during the installation process. Sharp bends or kinks in the lines will cause restrictions.

IMPORTANT

Only use brazing rods/sticks which are suitable/recommended for air conditioning pipework installations - Do Not Use Soft Solder.

IMPORTANT

The compressor in the unit this air handler is matched with contains PVE oil (Polyvinyl ether). PVE oil is formulated for hydrofluorocarbon (HFC) refrigerants, such as R410A, which this system contains. While it may have some miscibility properties with mineral-based oil and POE oil (Polyolester), it is not recommended to mix PVE oil with any other type of refrigerant oil.

IMPORTANT

Support ALL piping within 12 in. (305 mm) of any mechanical fitting such as a flared connection.

- Field provided piping consists of two HVAC/R rated copper lines connected to the indoor unit.
- Final equipment connections must be brazed connections. Compression or other types of fittings are not permitted for final connections.
- Refrigerant lines must be connected by a qualified technician in accordance with established procedures.
- Copper-phosphorous brazing alloys are to be used to join all pipework connections where applicable.
- Always flow/purge nitrogen to avoid oxidation while brazing.
- Always use an appropriate heat absorption compound to protect the unit and internal sensors from conductive heat while brazing.

Table 2. Refrigerant Piping Connections

Indoor Unit Size (Btuh)	Liquid Line	Vapor Line
7,000	1/4"	1/2"
9,000		
12,000		
15,000		
18,000	3/8"	5/8"
24,000		
30,000		
36,000		
48,000		

1. The seal on the unit refrigerant piping connections should remain in place until the last possible moment. This will prevent dust or moisture from getting into the refrigerant piping before it is connected.
2. Prior to brazing remove rubber air grommets from indoor unit refrigerant line ports.
3. Slowly loosen one of the rubber plugs to release the factory nitrogen charge. Remove the rubber plug from both liquid and gas lines or cut pipework tails to suit field installation conditions.
4. All refrigerant piping shall be free of defects, debris, and oil.
5. Connect the liquid and gas lines to the evaporator coil.
6. Always use an appropriate heat absorption compound to protect the unit and internal sensors from conductive heat while brazing. Take care to protect the cabinet and internal components.
7. Ensure nitrogen is flowing at all times during the brazing process.
8. Braze connections. Allow pipe to cool before removing wet rag.
9. Reinstall the rubber grommets into the refrigerant piping panel.
10. Insulate both pipes individually.

VMDB007-015

Use provided piping reducers.

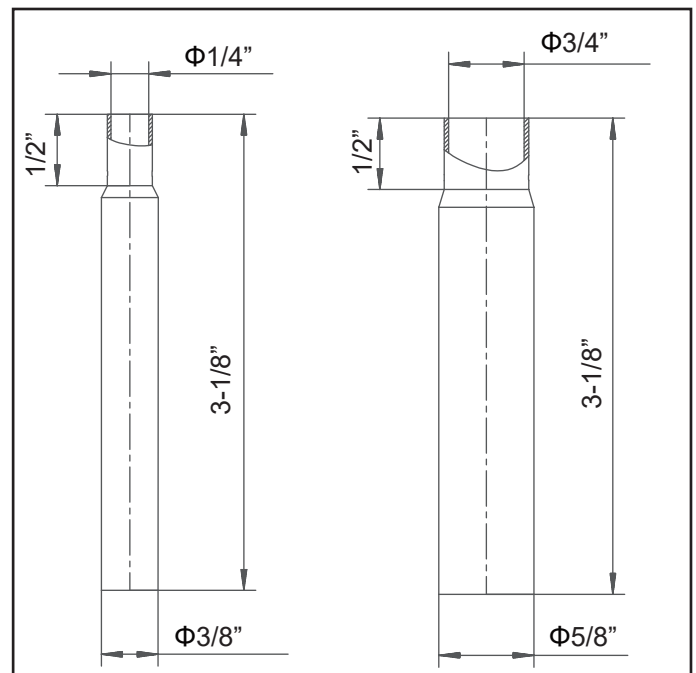

Figure 15. VMDB007-015 Piping Reducers.

Sealing the Unit

Seal the unit so that warm air is not allowed into the cabinet. Warm air introduces moisture, which results in condensation problems.

This is especially important when the unit is installed in an unconditioned area.

If installed in an unconditioned space, sealant should be applied around the electrical wires, refrigerant tubing, and condensate lines where they enter the cabinet.

! WARNING

There must be an air-tight seal between the unit and the return air plenum. Use fiberglass sealing strips, caulking, or equivalent sealing method between the plenum and the air handler cabinet to ensure a tight seal. Return air must not be drawn from a room where this unit or any gas-fueled appliance (i.e. water heater) or carbon monoxide-producing device (i.e. wood fireplace) is installed.

Condensate Piping Connections

CAUTION

Make sure that drain piping is properly routed and insulated in order to prevent both leaks and condensation. Follow these instructions exactly to ensure proper drainage and unit operation.

1. Use the provided hose clamp to secure the provided flexible condensate drain connector and insulating sleeve to the drain line stub on the side of the indoor unit. See Figure 16. **NOTE** - Take care not to overtighten the hose clamps this may damage the drain line stub.

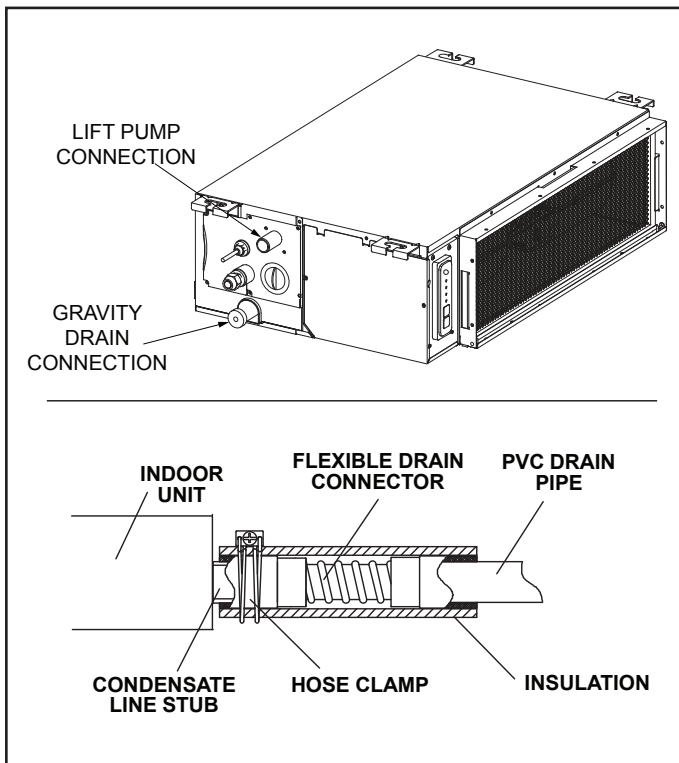

Figure 16. Condensate Drain Connection

2. Make a water-tight connection between the field-provided condensate drain line and the flexible condensate connector (1 in. O.D.).
3. See Figure 17 for applications including a single unit and a single gravity drain. In this case, ensure that the drain line is properly sloped (no less than 1/4 inch per foot) and condensate lines are routed to ensure moisture is drained away from the indoor unit. A gravity drain connection port is located on the side of the unit with the refrigerant piping and on the opposite side of the unit. Select one connection to use and leave the unused connection port sealed. Seal and plug the lift pump connection port when using either gravity drain connection port. Disconnect the factory-installed lift pump, CN 13.

4. See Figure 18 for applications including a single unit using the internal drain pump.

IMPORTANT

You must confirm operation of every drain and pump in the system as part of the commissioning procedure.

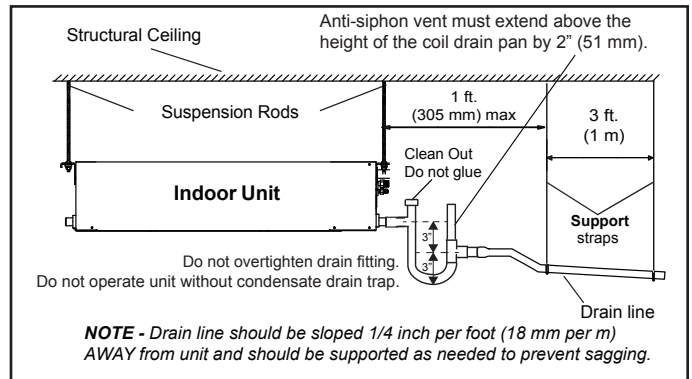

Figure 17. Sloped Condensate Gravity Drain Single Unit

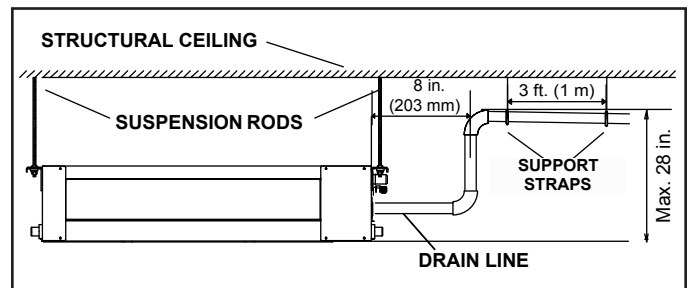
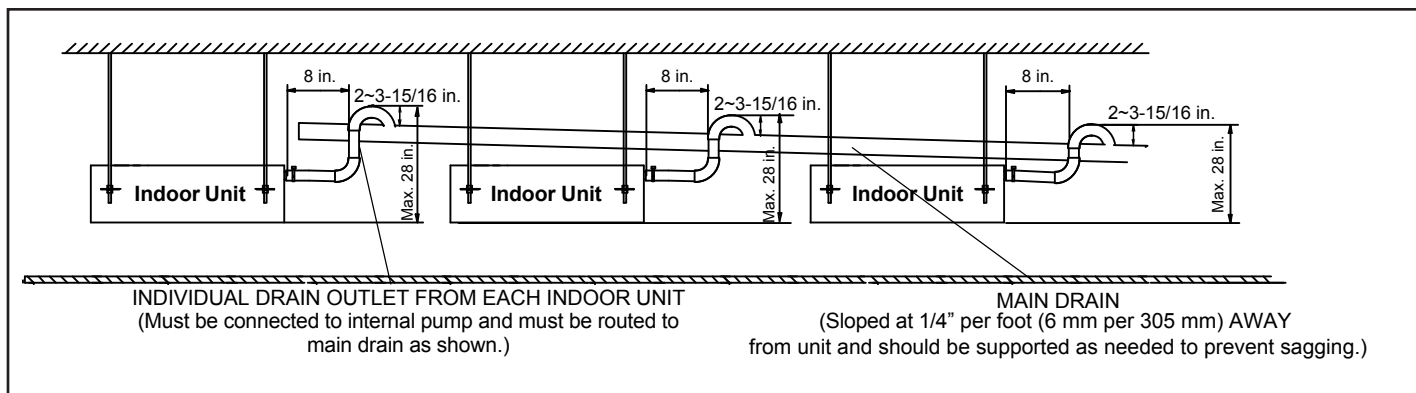

Figure 18. Condensate Drain with Lift Pump Single Unit

5. See Figure 19 for applications including multiple units using the internal pump to provide lift into a single, correctly sized main drain. In this case, ensure that the main drain line is properly sloped, no less than 1/4 inch per foot (6 mm per 305 mm), and that each individual drain is connected to the main drain exactly as shown.
6. In all cases, drain should be as short as possible and should not have any droops or kinks that would restrict condensate flow and shall be constructed using an approved pipe. **There must be a 2-inch (51 mm) space between the end of the condensate drain and the final termination point (ground, open drain, etc.) to ensure that the line will drain freely.**



**Figure 19. Condensate Drain with Lift Pump
Multiple Indoor Units**

! IMPORTANT

When using a gravity drain instead of the factory-installed lift pump.
Disconnect the factory-installed lift pump, CN 13. See unit wiring diagrams for location of CN 13.

! IMPORTANT

Drain should have a slope of at least 1/4 inch per foot and should be approved corrosion-resistant pipe. You must confirm operation of every drain and pump in the system as part of the commissioning procedure.

7. After system installation is complete, the condensate drain line must be checked for leaks and the condensate pumps must be checked to ensure proper operation. This check is part of the commissioning sequence. Turn the condensate drain pan test cover latch counterclockwise to open the cover and access the drain pan. See Figure 20. Funnel enough water to engage the pump into the drain pan through a flexible tube.
8. Operate the system in the cooling mode. If the internal pump is being used, ensure that the pump is operating and the water in the pan is draining freely. If the internal pump is not being used, pour the water into the drain pan and confirm that it has flowed freely out of the pan and out of the drain termination. If a leak is found, shut down power to the unit at once and do not restore power to the unit until the problem has been resolved.

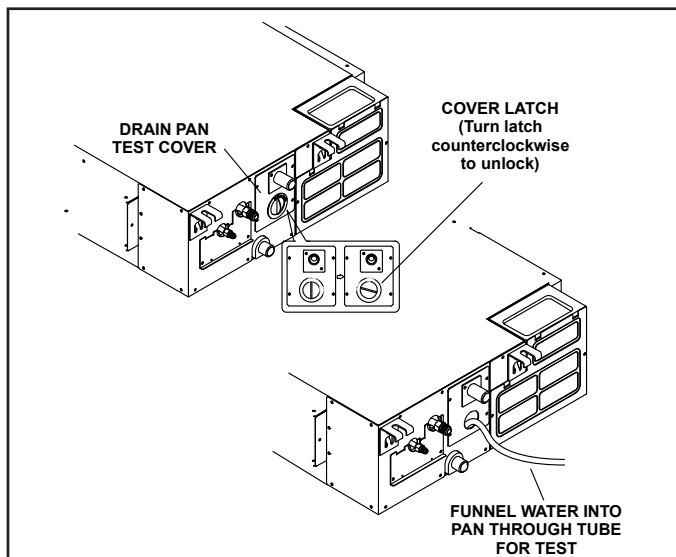

Figure 20. Condensate Drain Test

9. Return the test cover and turn the latch clockwise to re-lock it.

Wiring Connections

WARNING

Isolate the power supply before accessing unit electrical terminals.

Install unit so that unit disconnect is accessible.

Follow all local and national codes, as well as this installation instruction, during installation. Do NOT overload electrical circuit, as this may lead to failure and possible fire.

Use specified wiring and cable to make electrical connections. Clamp cables securely and make sure that connections are tight to avoid strain on wiring. Insecure wiring connections may result in equipment failure and risk of fire.

Wiring must be installed so that all cover plates can be securely closed.

In the U.S.A., wiring must conform with current local codes and the current National Electric Code (NEC). In Canada, wiring must conform with current local codes and the current Canadian Electrical Code (CEC).

Refer to unit nameplate for minimum circuit ampacity and maximum overcurrent protection size.

NOTE - Two-conductor stranded shielded cable must be used for the communication wiring. This is necessary to ensure proper system communication and operation.

- A circuit breaker capable of shutting down the power supply to the entire system must be installed.
- A single switch can be used to supply power to units on the same system. However, branch switches and circuit breakers must be selected carefully.
- Fit the power supply wiring of each unit with a switch and fuse as shown in the wiring diagram.
- Install a wiring interrupter or ground-fault circuit interrupter for the power wiring.
- Make sure the ground resistance is no greater than 100Ω. This value can be as high as 500Ω when using a grounding fault circuit interrupter since the protective ground resistance can be applied.

CAUTION

This unit must be properly grounded and protected by a circuit breaker. The ground wire for the unit must not be connected to a gas or water pipe, a lightning conductor or a telephone ground wire.

Do not connect power wires to the outdoor unit until all other wiring and piping connections have been completed.

Install all wiring at least 3 feet away from televisions, radios or other electronic devices in order to avoid the possibility of interference with the unit operation.

Do not install the unit near a lighting appliance that includes a ballast. The ballast may affect remote control operation.

CAUTION

A disconnection device having an air gap contact separation in all active conductors should be incorporated in the fixed wiring according to the National Wiring Regulation.

1. Remove the screws that secure the control box cover. Remove the cover and place it to the side where it will not be damaged.
2. Locate the terminal strip in the control box. Connect the power wiring (sized per NEC/CEC and local codes) and communications cable (two-conductor, shielded cable) per Figures 21, 22 and 23. Refer to unit nameplate for rated voltage.
3. If the indoor unit is the final unit in a group that is wired in series, install the provided resistor across terminals P and Q.
4. The infra-red receiver / display panel can be repositioned, if necessary. Use optional extension cable kit V0CTRL93P-1 (cat # 14R84).

Indoor units and mode selection boxes on the same refrigeration circuit should have a common power supply but must have an independent disconnect switch installed adjacent to each item of equipment for servicing

and maintenance purposes. Indoor unit and mode selection box power supply MUST not be taken from the outdoor unit. Always follow NEC/CEC and Local Codes.

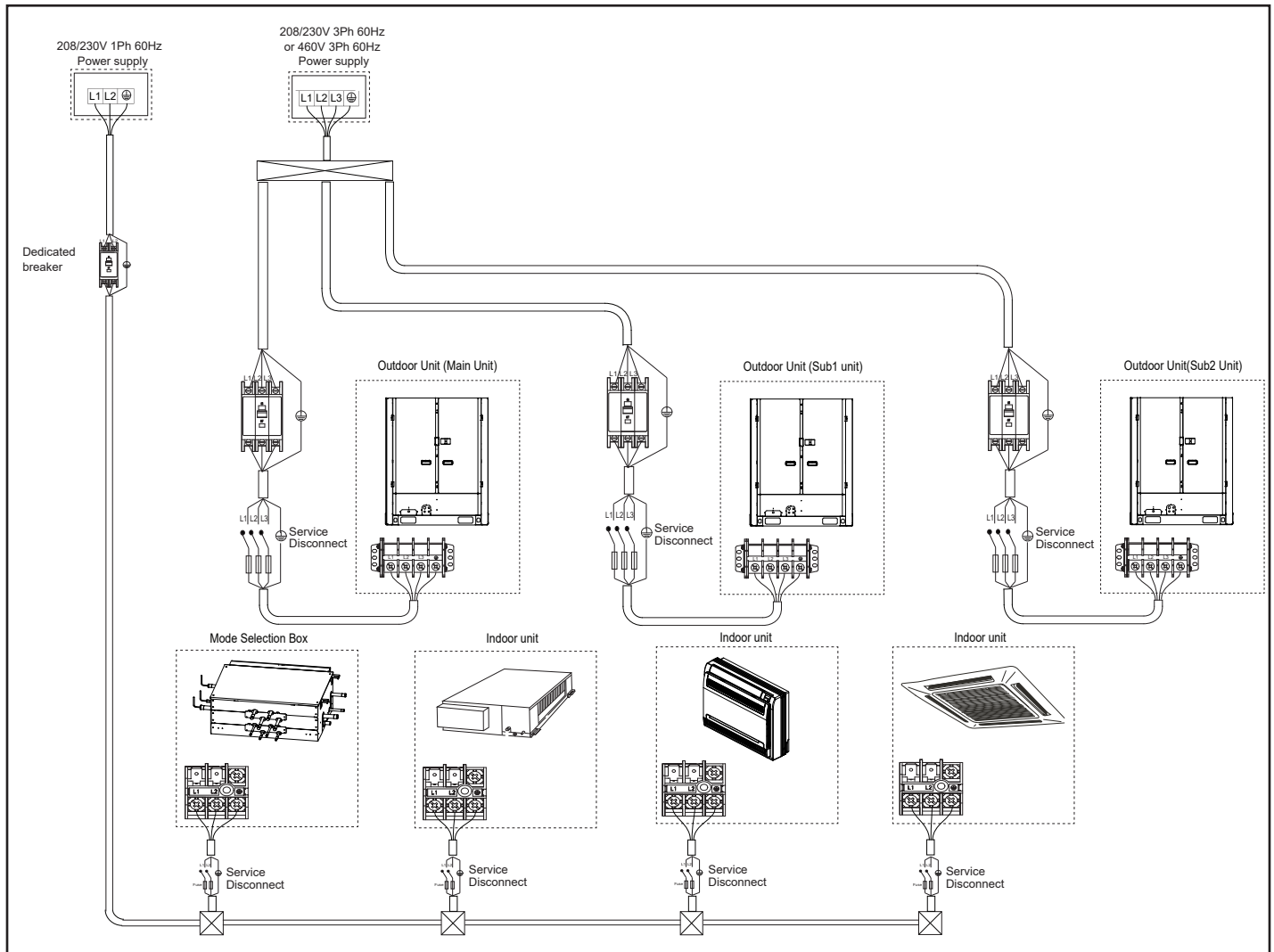

Figure 21. Typical Power Wiring Diagram (VRF Heat Recovery System Shown)

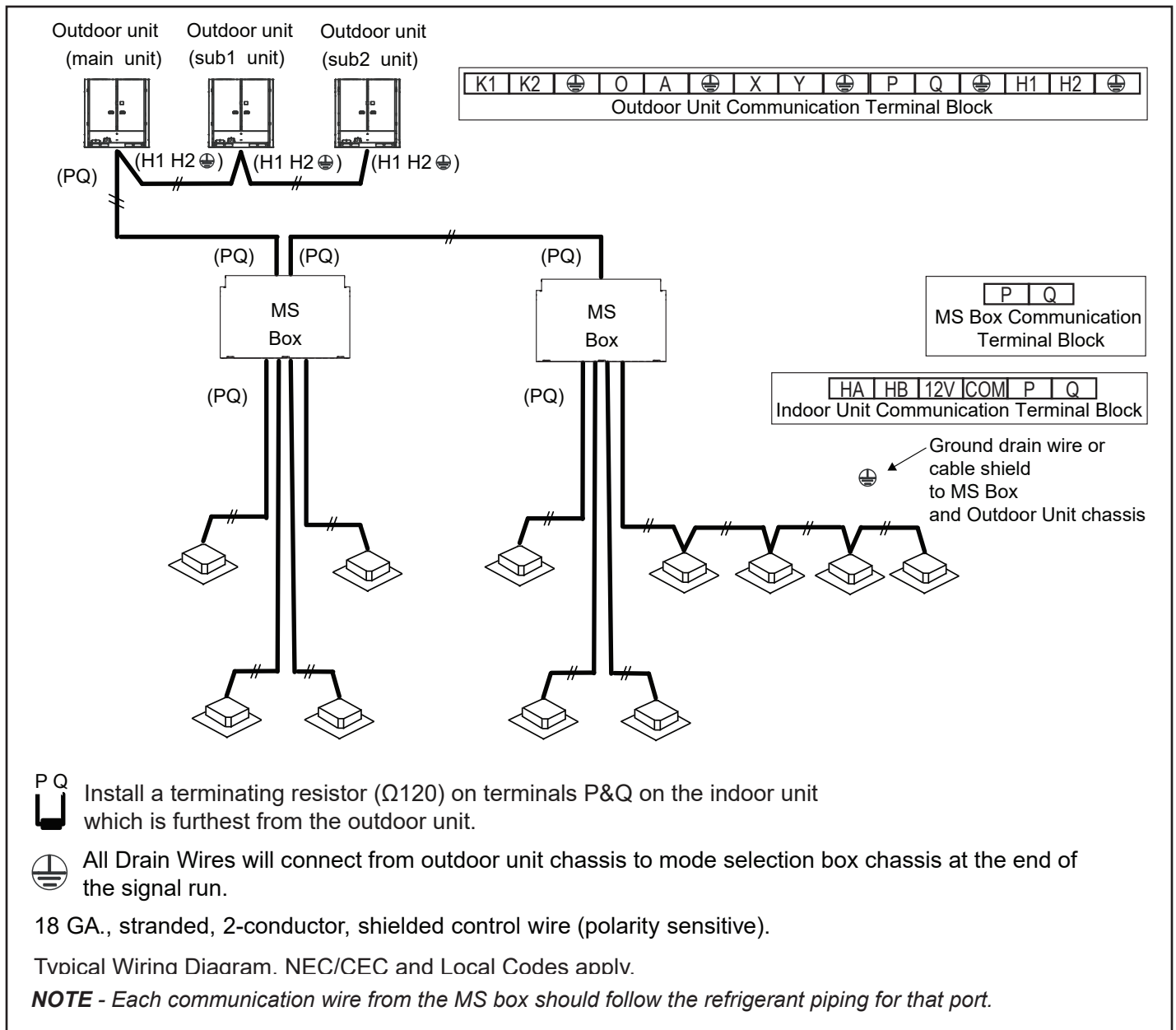

Figure 22. Typical Communication Wiring Diagram (VRF Heat Recovery System)

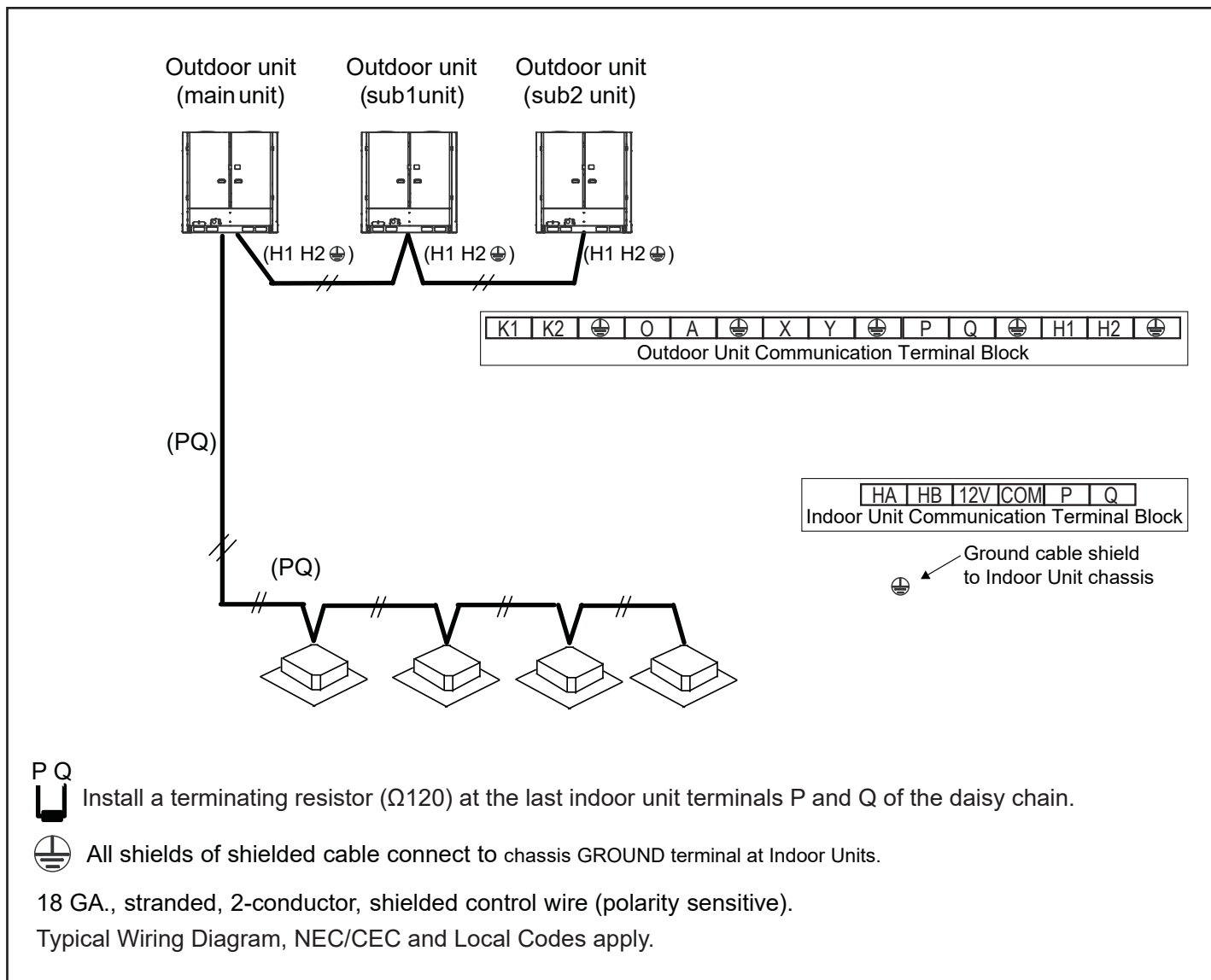

Figure 23. Typical Communication Wiring Diagram (VRF Heat Pump System)

Tightening torque for the terminal screws

- Use the correct screwdriver for fighting the terminal screws. If the screwdriver blade is too small, the head of the screw might be damaged, and the screw will not be properly tightened.
- If the terminal screws are over tightened, screws might be damaged.
- Refer to the table below for the tightening torque of the terminal screws.
- After wiring, confirm all connections are correct; Then turn on power supply to the unit.

Table 3. Terminal Screw Tightening Torque

	Tightening torque (lb-ft)
Terminal base of remote controller/Signal transmission wire (X2M)	0.58-0.72
Terminal base of power supply (X1M)	0.87-1.06
Grounding terminal (M4)	1.06-1.43

⚠ IMPORTANT
 DO NOT adjust DIP switch settings. Settings may only be adjusted by a trained technician as part of the commissioning procedures.

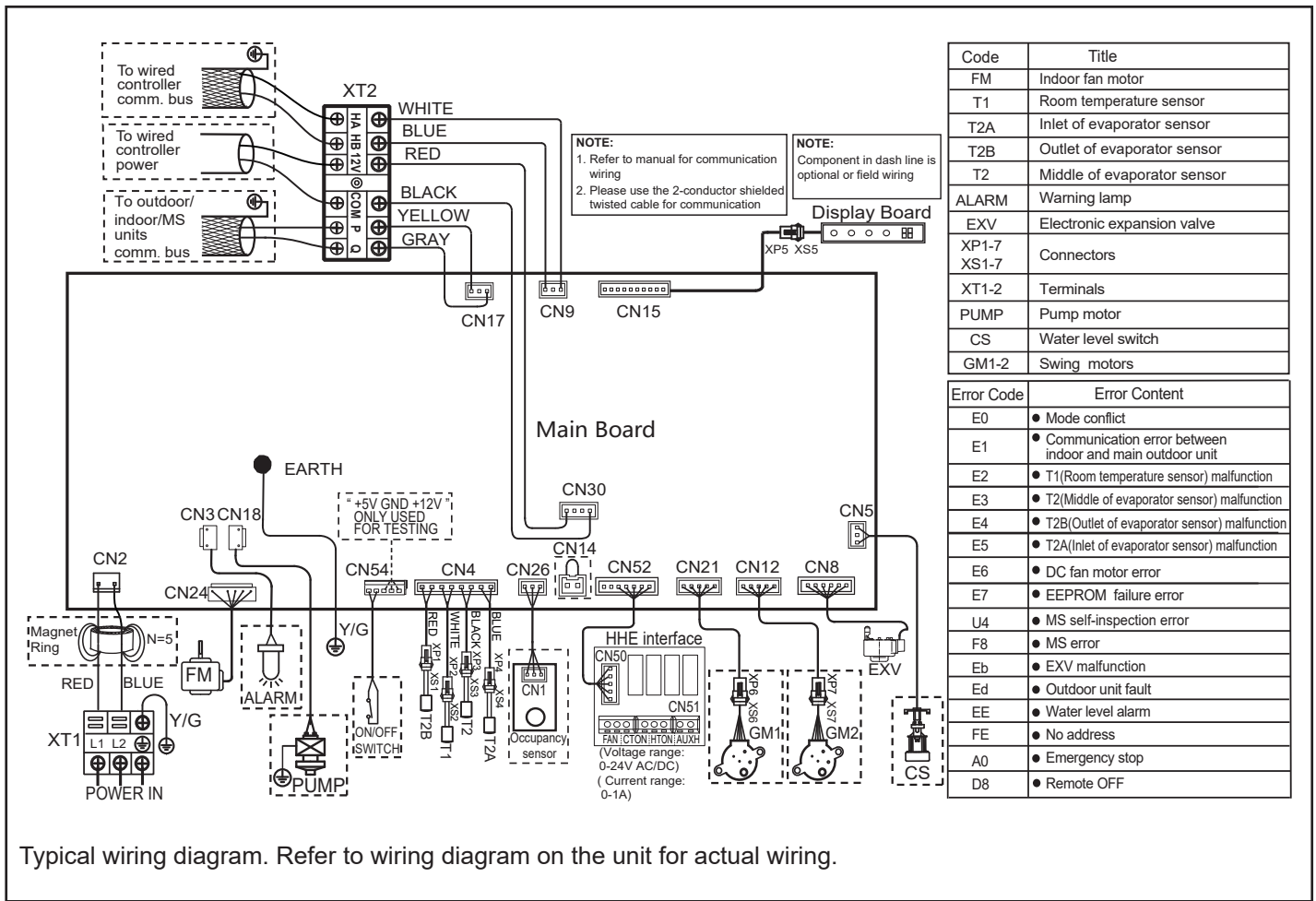

Typical wiring diagram. Refer to wiring diagram on the unit for actual wiring.

Figure 24. Wiring Diagram - VMDB007-048-P3 Wiring Diagram

Relocate T1 Return Air Sensing

Relocate the unit return air sensing from inside the unit to a location within the conditioned zone whenever the return is pulling air from above the ceiling or if fresh air is being introduced and mixed into the return. The T1 sensor cannot accurately read the space temperature under these conditions if the sensing remains located inside of the unit.

Two methods of relocating the return air sensing are:

1. Set return air sensing to the wired local controller. See the specific controller's installation and user manual for instructions.
2. Relocate physical T1 sensor. Instructions below.

Relocate Physical T1 Sensor Instructions

This sensor can be extended with 18 AWG stranded shielded cable.

1. Identify the T1 connection on the main board - CN4. (white wires soldered to PCB)

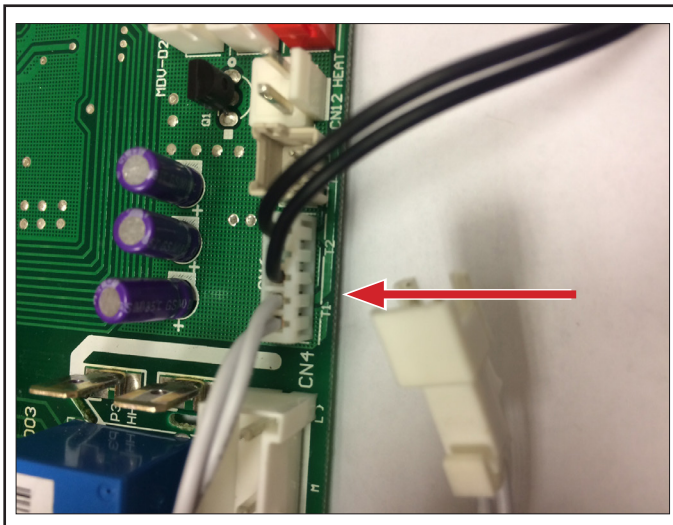

Figure 26. Identify T1 Sensor Connection on PCB

2. Identify where the white wire is plugged into the black wire.

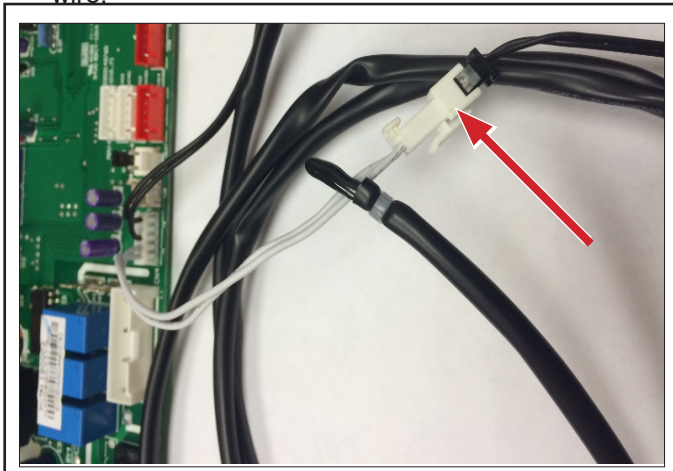

Figure 27. Identify White Plug into Black Wire

3. Cut the black wire between the plug and the sensor thermistor. Leave adequate room for making wiring connections on each end.

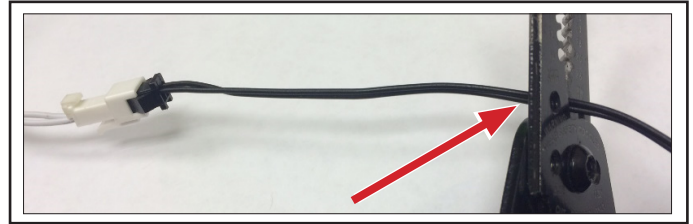

Figure 28. Cut the Black Wire

4. Prepare the 18 AWG stranded shielded extension cable.
5. Solder the extension cable to the black wire on each end or use the VRF accessory V0SNSR00P to splice in the extension cable.
6. Locate the return air thermistor to the conditioned area of which the indoor unit serves.

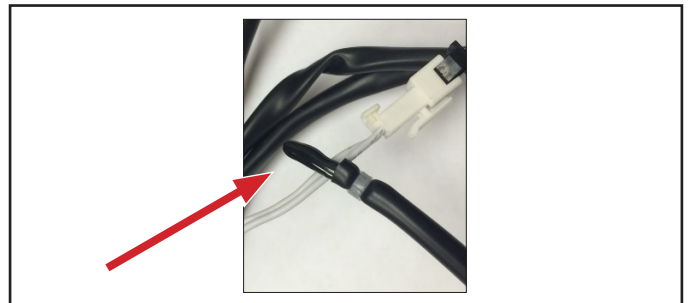

Figure 29. Sensor Thermistor

! IMPORTANT

Avoid installing sensor in high load or heat loss areas such as exterior walls or walls that are against unconditioned spaces, near entry doors and windows, or where direct sunlight may be present.

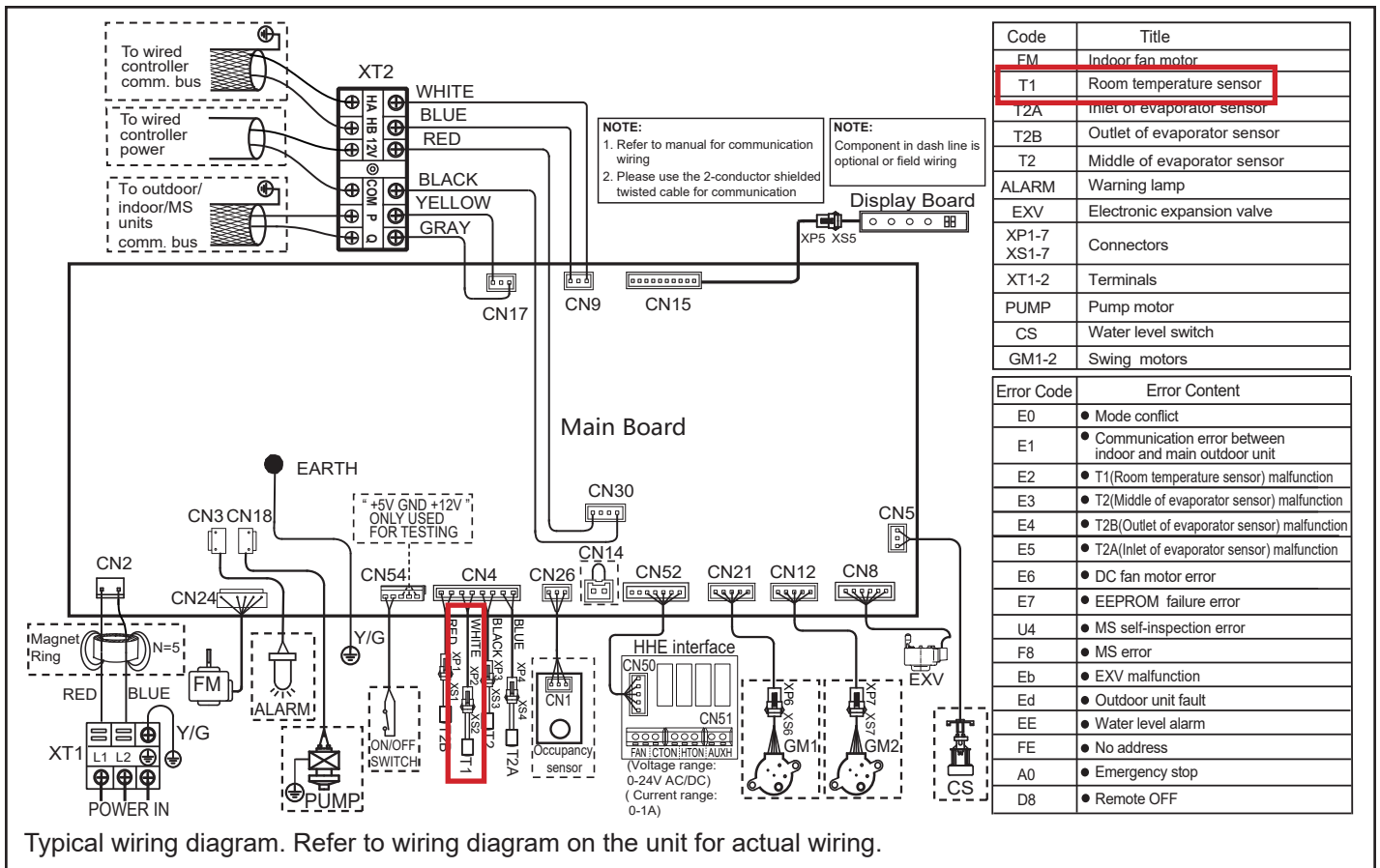

Figure 30. Identify T1 Sensor on Wiring Diagram

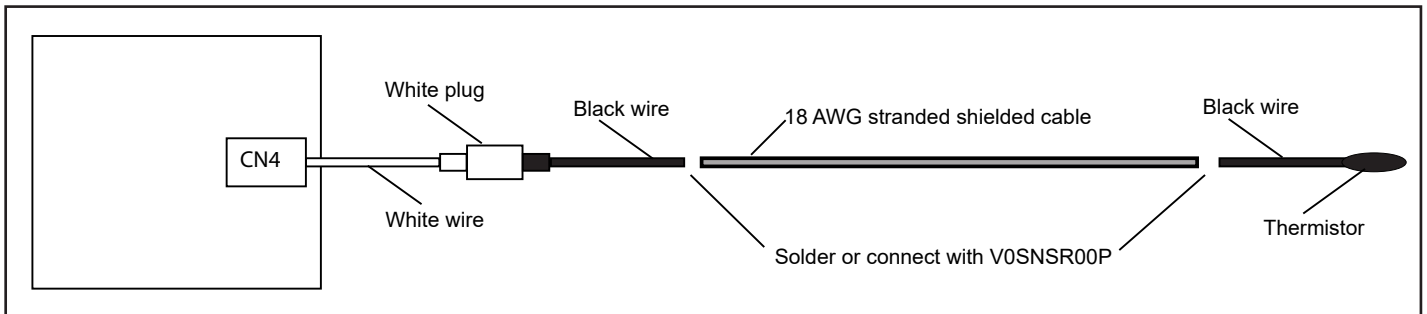

Figure 31. Typical Wiring Connections

Setting Blower Operation

Blower cycling can be configured to determine indoor operation.

- Default operation is indoor unit blower OFF when the indoor unit is in thermo OFF.
- Settings can be adjusted in the -3P controller and cannot be configured at the indoor unit PCB.

- Consult the specific controller manual for detailed blower setting information.

NOTE - Ensure the blower is set to the ON position when using an electrical duct heater.

Network Address and Commissioning

After the system has been installed, each indoor unit must be assigned an address as part of the commissioning procedure.

Spot Check Instructions

Use the Spot Check Performance tables below and the Manual button on the unit receiver to view diagnostic information the indoor unit.

Table 4. Spot Check Performance Identification Table

No.	Content	Recorded Value/Date
0	Normal display	
1	Communication address of indoor unit	
2	Indoor unit capacity (horsepower)	
3	Network address of indoor unit	
4	The actual setpoint temperature	
5	The actual indoor temperature T1	
6	The middle coil temperature T2	
7	The coil inlet temperature T2A	
8	The coil outlet temperature T2B	
9	The actual superheat temperature	
10	The actual subcool temperature	
11	Error Code	
12	Indoor software version	
13	End (--)	

This Spot Check Performance table is located on the unit service panel.

The diagnostic information can also be obtained using the wired remote controller.

Digital Display

The indoor unit is equipped with a receiver that has a digital display that provides an error code. Refer to the table below to view the error codes. The error code will replace the temperature setting displayed on the receiver. If more than one error has occurred, the codes will alternate so that all codes are shown.

Make note of the code (E1, EE, etc.), then reset the display by pressing the ON/OFF button on the unit controller. Press the ON/OFF button a second time to reapply power to unit. If the code is still displayed, disconnect and restore power at the unit disconnect switch or circuit breaker. If the problem was temporary, the code will not reappear. If the error code reappears after power has been broken and restored at the disconnect switch or circuit breaker, call VRF Technical Support 1-844-438-8731.



Figure 32. Receiver/Display

Table 7. Fault Code Display on Indoor Unit Receiver

Error Code	Description
FE	No address
E0	Mode conflict
E1	Communication error between indoor and main outdoor unit
E2	T1 (Room temperature sensor) malfunction
E3	T2 (Middle of evaporator sensor) malfunction
E4	T2B (Outlet of evaporator sensor) malfunction
E5	T2A (Inlet of evaporator sensor) malfunction
E6	DC fan motor error
E7	EEPROM failure
Eb	EXV malfunction
Ed	Outdoor unit Fault
EE	High Water Alarm
A0	Emergency stop
D8	Remote off
U4	MS self-inspection error
F8	MS error

Table 8. Fault Code Display on Controller

Error Code	Description
F0	Communication/Address error between indoor units and wired controller
F1	Communication/Wiring error between indoor units and wired controller
E2	Controller temperature sensor error

Technical Support

1-844-GET-VRF1

(1-844-438-8731)

vrftechsupport@lennoxind.com

www.LennoxVRF.com

Download the app
from the Apple App Store or the Google Play store.

