

WARNING

Improper installation, adjustment, alteration, service or maintenance can cause property damage, personal injury or loss of life. Installation and service must be performed by a licensed professional installer (or equivalent), service agency or the gas supplier.

CAUTION

As with any mechanical equipment, personal injury can result from contact with sharp sheet metal edges. Be careful when you handle this equipment.

INSTALLATION INSTRUCTIONS

UH(RS,CM)

30,000 to 400,000 Btuh Series

UNIT HEATERS

507938-04

6/2020





Supersedes 507938-03

Note - Unit heaters are designed for indoor use only.

Table Of Contents

Shipping and Packing List.....	2	Gas Connection	21
UHRS-030/105 Compact Unit Dimensions.....	3	Leak Check	22
Compact Unit Parts Arrangement.....	4	Unit Start-Up	22
UHCM-125/200 Standard Unit Dimensions	5	To Turn Off Gas to Unit	23
UHCM-250/400 Standard Unit Dimensions	6	Heating Sequence of Operations	23
Standard Unit Parts Arrangement.....	7	Gas Flow.....	23
Optional Accessory.....	8	Gas Pressure Adjustments.....	23
Requirements in USA	8	Ignition Control LED.....	24
Requirements in Canada.....	8	High Altitude Adjustments.....	24
Additional Requirements	9	Limit Control Switch.....	25
Unit Heater Installation	9	Louver Vane Adjustment	25
Combustion and Ventilation Air.....	10	Combustion Air Pressure Switch	25
Rotation of Combustion Air Inducer - 125/150.....	11	Flame Roll-out Switch	25
Venting.....	11	Service.....	25
Electrical Connections	16	Start-Up and Performance Checklist	27

RETAIN THESE INSTRUCTIONS FOR FUTURE REFERENCE

		<h2> WARNING</h2> <p>FIRE OR EXPLOSION HAZARD.</p> <p>Failure to follow safety warnings exactly could result in serious injury, death, or property damage.</p>	
<p>Be sure to read and understand the installation, operation and service instructions in this manual.</p> <p>Improper installation, adjustment, alteration, service or maintenance can cause serious injury, death or property damage.</p> <p>Do not store or use gasoline or other flammable vapors and liquids in the vicinity of this or any other appliance.</p> <p>Installation and service must be performed by a qualified installer, service agency or the gas supplier.</p>	<h3>WHAT TO DO IF YOU SMELL GAS:</h3> <ul style="list-style-type: none">• Do not try to light any appliance.• Do not touch any electrical switch; do not use any phone in your building.• Leave the building immediately.• Immediately call your gas supplier from a neighbor's phone. Follow the gas supplier's instructions.• If you cannot reach your gas supplier, call the fire department.		



Shipping and Packing List

UHRS30-105 Units

Package 1 of 1 contains:

- 1-Unit Heater
- 2-Hanging brackets
- Bag assembly containing:
 - 1-Warranty card
 - 1-Brand logo badge
 - 8- 10-16 X 5/8" SDST screws
 - 1-3/8" Snap bushing
 - 3-Wire ties

The heater is shipped completely assembled. Check the unit for shipping damage. The receiving party should contact the last carrier immediately if any shipping damage is found.

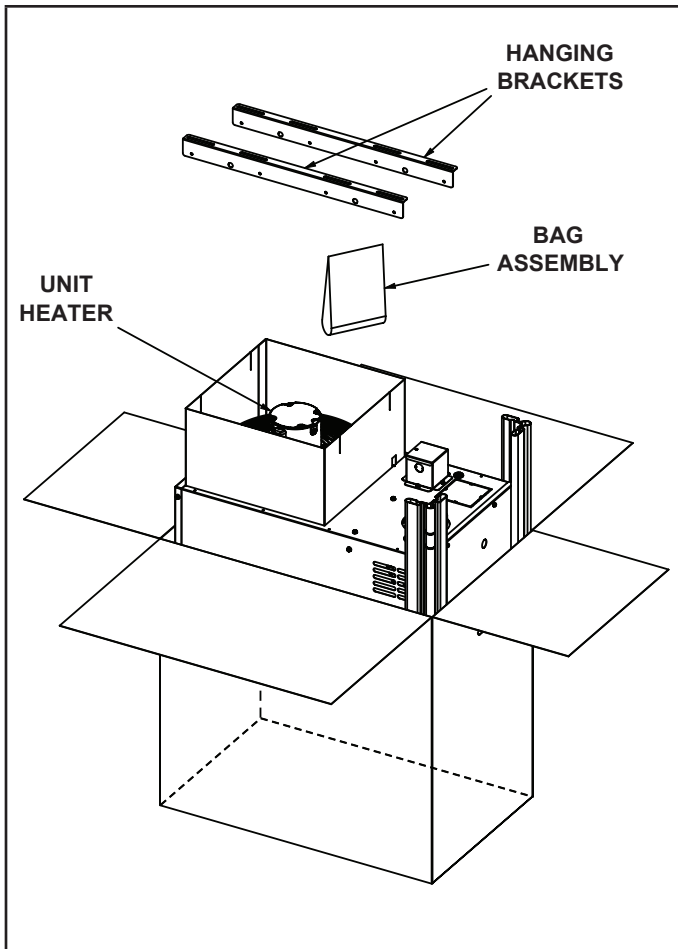

Shipping and Packing List

UHCM 125-400 Units

Package 1 of 1 contains:

- 1-Unit Heater
- 1-Burner box hood
- 1-5" Diameter Flue transition (6" diameter on 350-400)
- Bag assembly containing:
 - 1-Warranty card
 - 1-Brand logo badge
 - 8- 10-16 X 5/8" SDST screws
 - 2-Wire ties

The heater is shipped completely assembled. Check the unit for shipping damage. The receiving party should contact the last carrier immediately if any shipping damage is found.

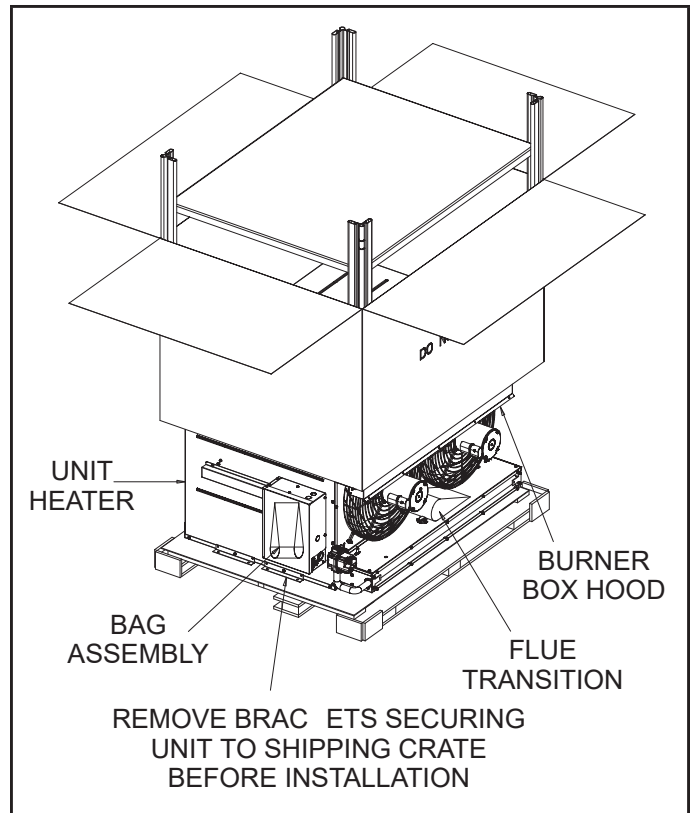

UHRS-030 / 105 DIMENSIONS - Inches (mm)

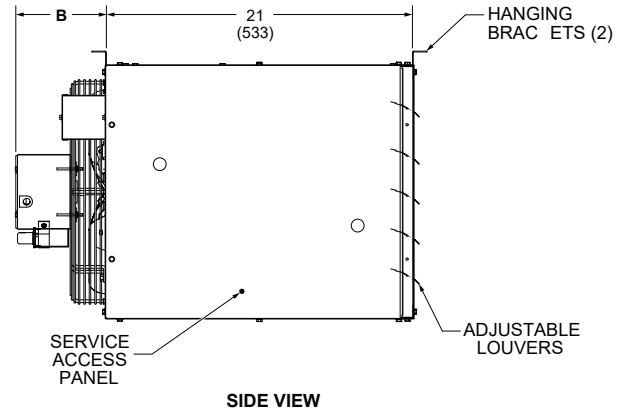
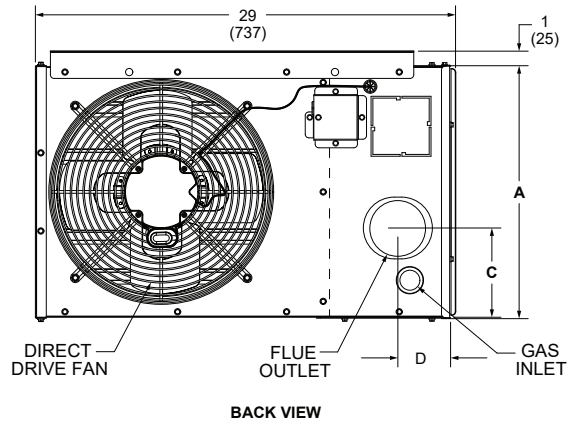
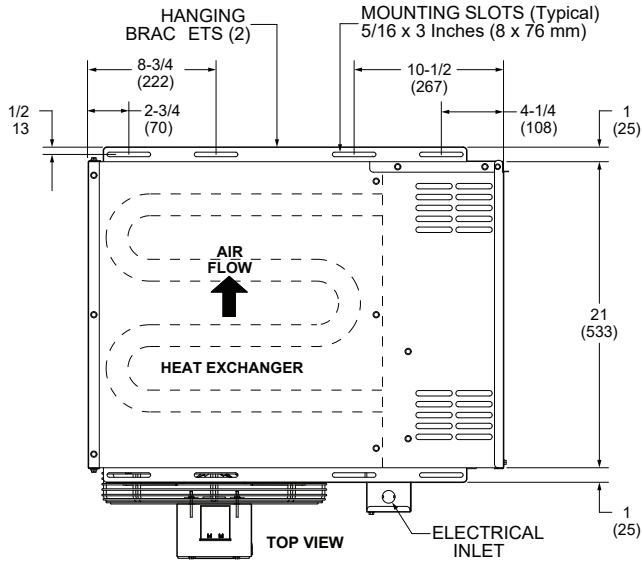

Model No.	A		B		C		D	
	in.	mm	in.	mm	in.	mm	in.	mm
UHRS-030A UHRS-045A	12-3/8	314	6-1/2	165	4	102	6	152
UHRS-060A UHRS-075A	17-1/2	445	6-1/4	159	6-1/8	156	3-5/8	92
UHRS-090A UHRS-105A	23	584	7-7/8	200	9-1/8	232	3-5/8	92

PARTS ARRANGEMENT 030K THRU 105K BTUH

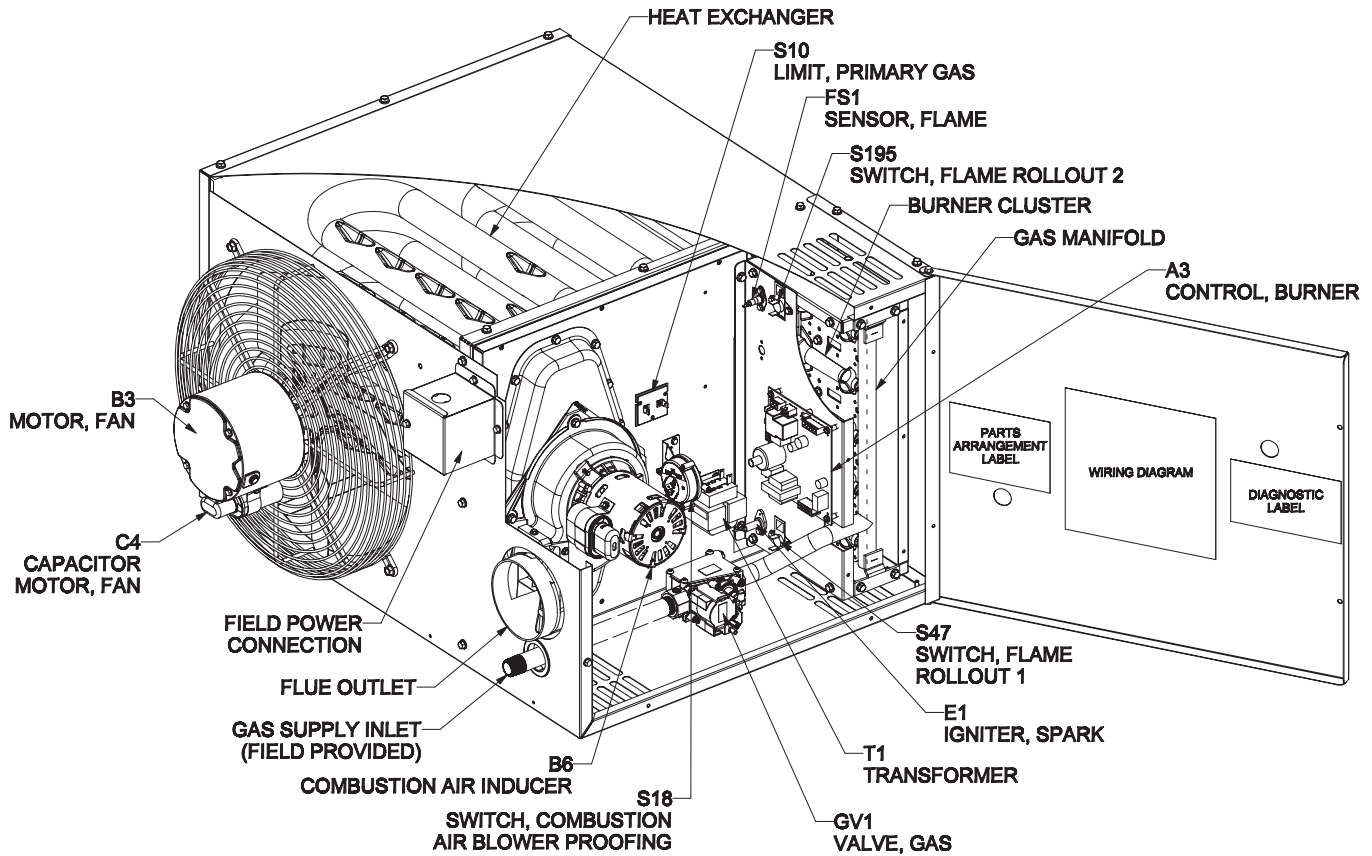

UHCM-125 / 200 DIMENSIONS - Inches (mm)

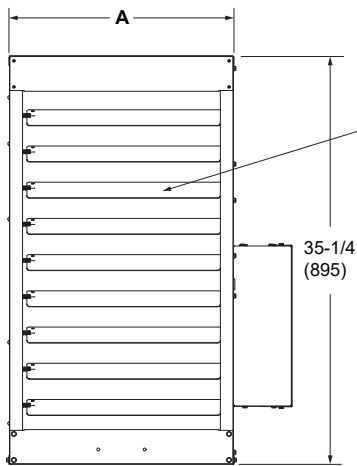
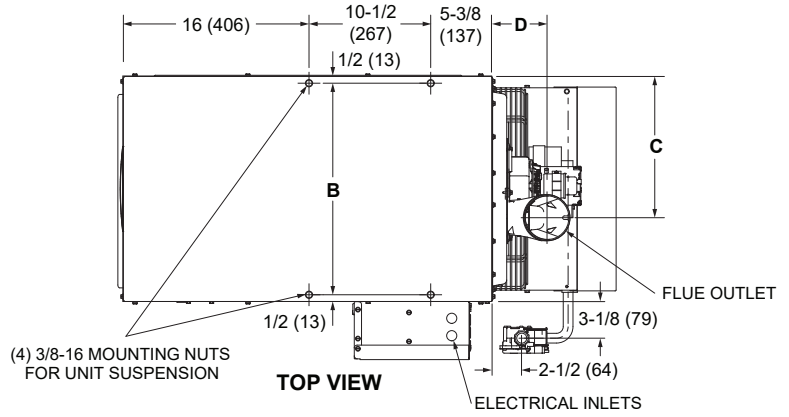

FRONT VIEW

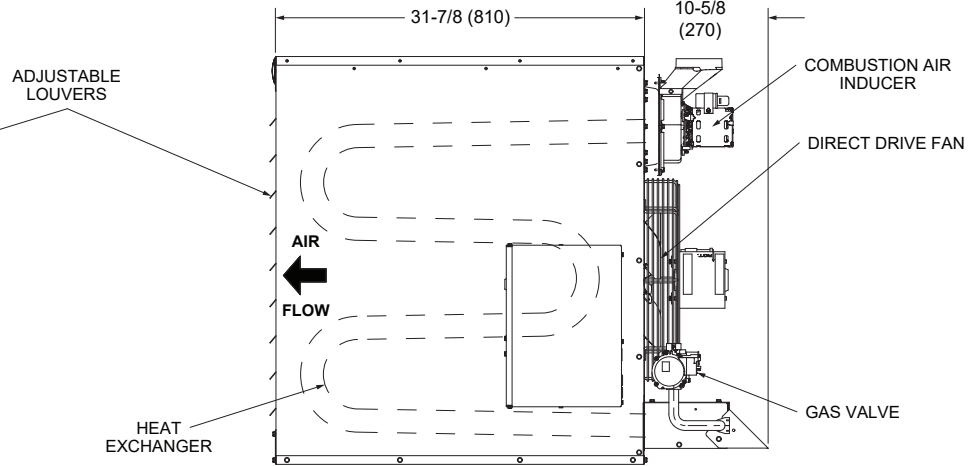

SIDE VIEW

Model No.	A		B		C		D	
	in.	mm	in.	mm	in.	mm	in.	mm
UHCM-125 UHCM-150	19-1/2	495	18-1/2	470	12-1/4	311	4-3/4	121
UHCM-175 UHCM-200	25	635	23-3/4	603	9-1/2	241	3	76

UHCM-250 / 400 DIMENSIONS - Inches (mm)

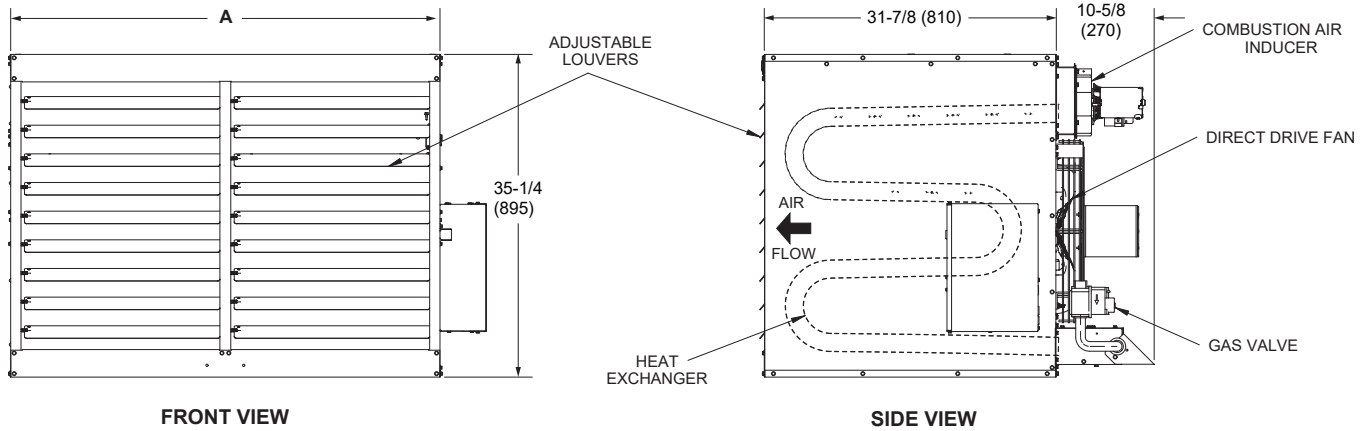
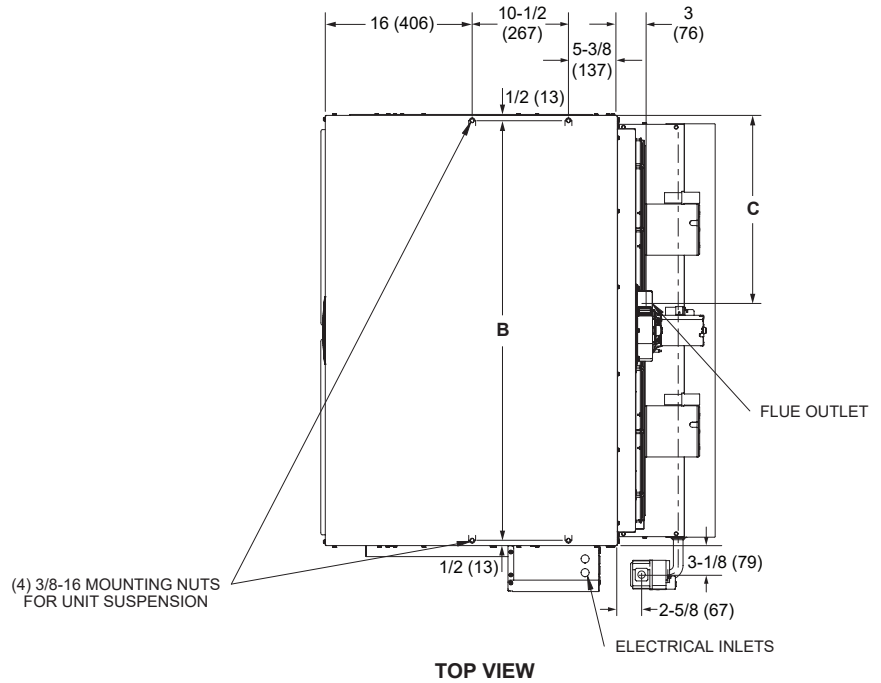

Model No.	A		B		C	
	in.	mm	in.	mm	in.	mm
UHCM-250 UHCM-300	37-5/8	956	36-1/2	927	15-7/8	403
UHCM-350 UHCM-400	47	1194	45-3/4	1162	20-1/2	521

**PARTS ARRANGEMENT
125K THRU 400K BTUH**

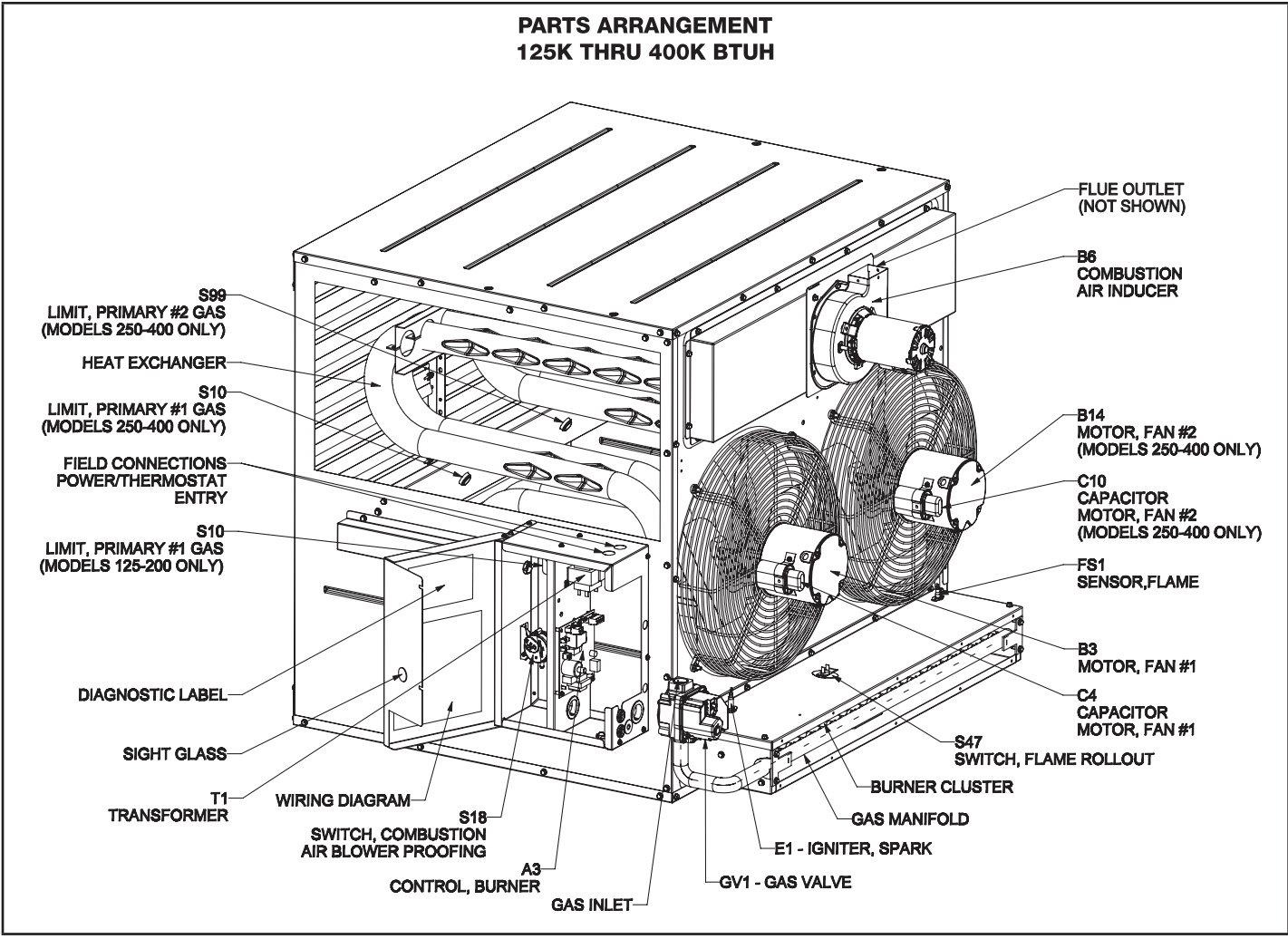

Optional Accessory

Units require a changeover kit when the unit is to be used with Natural gas. The kit is ordered separately. See Engineering Handbook.

Requirements in USA

Installation of gas unit heaters must conform with local building codes or, in the absence of local codes, with the current edition of ANSI Z223.1, National Fuel Gas Code. Installation in aircraft hangers must be in accordance with the current edition of ANSI/NFPA No. 409, Standard for Aircraft Hangers.

Installation in parking structures must be in accordance with the current edition of ANSI/NFPA No. 88A, Standard for Parking Structures.

Installation in repair garages must be in accordance with the current edition of ANSI/NFPA No. 88B, Standard for Repair Garages.

These units are approved for residential garage or non-confined living space applications. For installation in a residential garage or non-confined living space, unit must be installed so that burners and ignition source are located no less than 18" (457mm) above floor. Heater must be located or protected to avoid physical damage by vehicles. Refer to the current edition of ANSI Z223.1, National Fuel Gas Code.

Authorities having jurisdiction should be consulted before installation. Air for combustion and ventilation must conform to the methods outlined in the current edition of ANSI Z223.1, Section 5.3, Air for Combustion and Ventilation, or applicable provisions of local building codes.

The National Fuel Gas Code (ANSI Z223.1) is available from:

American National Standard Institute Inc.
11 West 42nd Street
New York, NY 10036

These unit heaters are CSA International design-certified. These unit heaters are certified for installation to combustible material as listed in Table 1 and on unit rating plate.

Accessibility and service clearances must be observed in addition to fire protection clearances.

All electrical wiring and grounding for unit must be in accordance with the regulations of the current edition of ANSI/NFPA No. 70, National Electric Code.

The National Electric Code is available from:

National Fire Protection Association

1 Batterymarch Park
PO Box 9101
Quincy, MA 02269-9101

Requirements in Canada

These instructions are intended only as a general guide and do not supersede local codes in any way. Authorities having jurisdiction should be consulted before installation. The installation must conform with local building codes or, in the absence of local codes, with the current edition of CSA-B149 installation compliance codes. All electrical wiring and grounding for the unit must also comply with the current edition of CSA C22.1, Canadian Electrical Code. These unit heaters are CSA-certified for the installation clearances listed on the rating plate and in table 1.

Adequate clearance must be provided around the appliance and around air openings into the combustion chamber. Provision shall be made for service accessibility.

NOTE - Fire protection clearances may be exceeded to provide additional space for service and accessibility.

GARAGE / WAREHOUSE INSTALLATIONS

- 1 - In a storage area, clearance from heaters to combustible materials must be such that the combustible material must not attain a temperature above 160°F (71°C) by continuous operation of the unit.

WARNING

Combustible materials that are affected by exposure to temperatures LESS than 160°F or 71°C (plastics, plastic wrap, styrofoam, cardboard, etc.) must be stored well away from this heater. Discharge air temperatures for these units can approach 250°F or 121°C.

- 2 - Maintain an 8-foot (2m) minimum clearance from the floor to the bottom of the heater. Refer to the current edition of CSA-B149 for installation compliance codes.

AIRCRAFT HANGER

- 1 - In an area where aircraft are housed or serviced, a 10-foot (3m) minimum clearance from the highest surface of the aircraft to bottom of the heater must be maintained.
- 2 - In other areas, an 8-foot (2m) minimum clearance from the floor to bottom of heater must be maintained.
- 3 - Heaters should be located so that they are protected from damage from aircraft or other appliances needed for servicing of aircraft. Refer to requirements of the enforcing authorities.

RESIDENTIAL

These units are approved for residential garage or non-confined living space applications. For installation in a residential garage or non-confined living space, unit must be installed so that burners and ignition source are located no less than 18" (457mm) above floor. Heater must be located or protected to avoid physical damage by vehicles. Refer to the current edition of CSA-B149 for installation compliance codes. In a confined area, the heater must be installed in accordance with the current edition of CSA-B149 installation compliance codes. Be sure to check with local codes and ordinances for additional requirements.

TABLE 1

UNIT CLEARANCES TO COMBUSTIBLE MATERIALS

Unit	Top		Side**		Bottom		Back		Flue	
	in	mm	in	mm	in	mm	in	mm	in	mm
030/105	1	25	1	25	1	25	18	457	6*	152
125/400	6	152	18	457	1	25	18	457	6	152

*6" is for single wall. Double wall B-vent clearance will be in accordance with the manufacturer's listing.

**Access panel or control box side of unit should have 24" (610mm) clearance.

Additional Requirements

The Commonwealth of Massachusetts stipulates the following additional requirements:

- 1 - Gas furnaces shall be installed by a licensed plumber or gas fitter only.
- 2 - The gas cock must be "T handle" type.

Unit Heater Installation

The appliance shall not be installed downstream from evaporator coils or cooling units.

Install the unit in the desired location as governed by clearances, vent connection, air direction, gas supply, electrical supply and service accessibility.

Unit is shipped ready for installation.

CAUTION

Do not install unit heaters in close proximity to fire sprinklers. Unit heater normal operating temperatures could result in fire sprinkler activation.

UHCM-125/400 UNITS

Four mounting nuts are furnished. Refer to dimension illustration. Mounting nuts will accommodate 3/8" x 16 threaded rods.

- 1 - Push each louver to the left to depress spring and release locking tab on the other end (locking tab keeps the louver in place for shipping).
- 2 - Rotate louvers to direct airflow as desired.
- 3 - Cut threaded rods to desired length and slide a 3/8" nut onto the rod.
- 4 - Slide a flat washer onto the threaded rod AFTER the nut (7/16" inside diameter X 1" outside diameter X 1/16" thick washer).
- 5 - Screw the rods (four) into the mounting nuts on the unit.
- 6 - Tighten nuts to secure unit to rods.
- 7 - Install the 3D brand badge provided with the unit.
- 8 - Install the burner box hood. See figure 1.

UHCM-125/400 MODELS

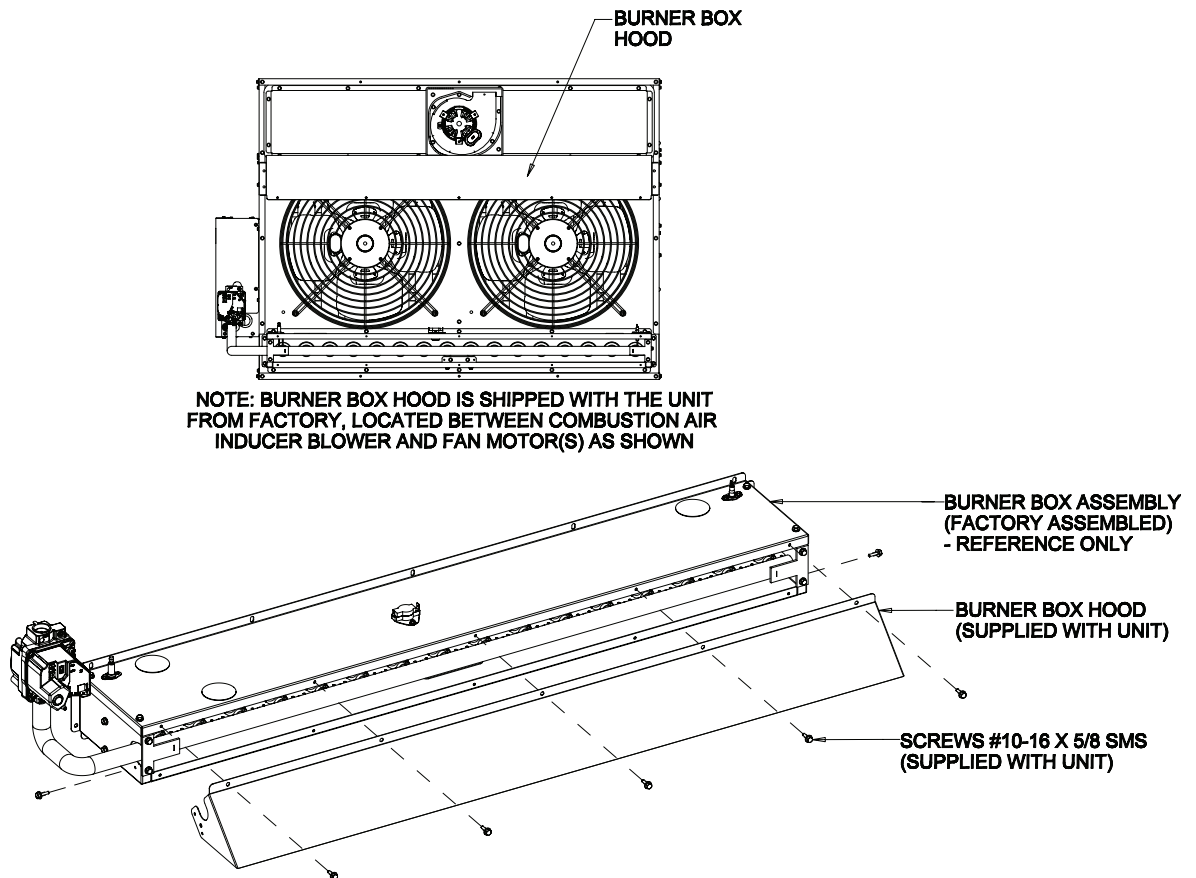

FIGURE 1

UHRS-30/105

Unit may be installed as shown in figure 2 or rotated 180°.

- 1 - Push each louver to the right to depress spring and release locking tab on the other end (locking tab keeps the louver in place for shipping).
- 2 - If installing unit in a rotated position - release locking tabs in the same manner as previous step. Rotate each louver 180° and reinstall. Remove and retain screws securing access panel. Rotate access panel 180° and re-secure using retained screws.
- 3 - Rotate louvers to direct airflow as desired.
- 4 - Choose location for mounting brackets.
- 5 - Align mounting brackets with pilot holes on the top or bottom (when rotating) edge of the unit. Secure with screws provided in bag assembly.
- 6 - To support unit, secure mounting bracket to ceiling joist or truss. Unit may also be supported using support rods as shown in figure 2.
- 7 - Install the 3D brand badge provided with the unit.

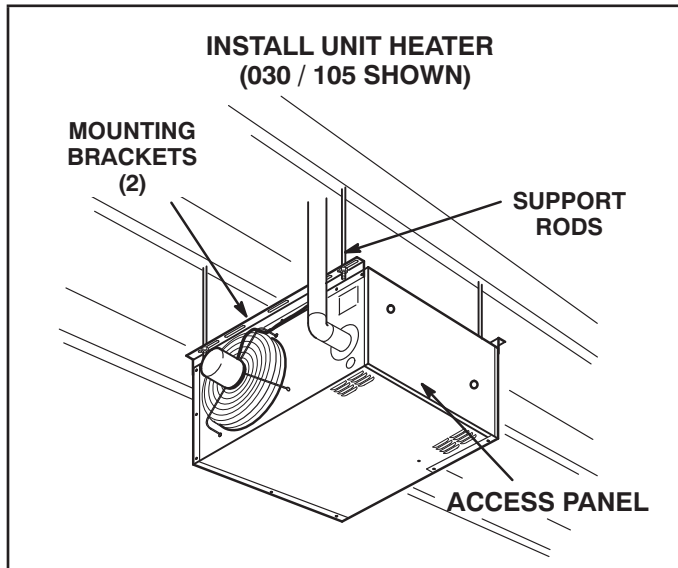

FIGURE 2

TABLE 2

MAXIMUM MOUNTING HEIGHTS

Unit	Feet (Meters)
UHRS-030/075	10 (3.0)
UHRS-090/105	12 (3.7)
UHCM-125/150	16 (4.9)
UHCM-175/200	20 (6.1)
UHCM-250/400	30 (9.1)

Combustion and Ventilation Air

Adequate facilities for supplying air for combustion and ventilation must be provided in accordance with the current edition of ANSI Z223.1, section 5.3 and CSA-B149 installation compliance codes, or applicable provisions of local building codes.

All gas-fired appliances require air to be used for combustion. In many buildings today, there is a negative indoor air pressure caused by exhaust fans, etc. If sufficient quantities of combustion air are not available, the heater or another appliance will operate in an inefficient manner, resulting in incomplete combustion which can result in the production of excessive carbon monoxide.

⚠ WARNING

Insufficient combustion air can cause headaches, nausea, dizziness or asphyxiation. It will also cause excess water in the heat exchanger resulting in rusting and premature heat exchanger failure. Excessive exposure to contaminated combustion air will result in safety and performance related problems. Avoid exposure to the following substances in the combustion air supply:

Permanent wave solutions
Chlorinated waxes and cleaners
Chlorine base swimming pool chemicals
Water softening chemicals
De-icing salts or chemicals
Carbon tetrachloride
Halogen type refrigerants
Cleaning solvents (such as perchloroethylene)
Printing inks, paint removers, varnishes, etc.
Hydrochloric acid
Cements and glues
Antistatic fabric softeners for clothes dryers
Masonry acid washing materials

If indoor air is to be used for combustion, it must be free of the following substances or the life of the heat exchanger will be adversely affected: chlorine, carbon tetrachloride, cleaning solvent, halogen refrigerants, acids, cements and glues, printing inks, fluorides, paint removers, varnishes, or any other corrosives.

Rotation of Combustion Air Inducer (UHCM-125 & 150 Only)

The combustion air inducer on UHCM-125 & 150 may be rotated 90° either to the left or right of the original vertical position in order to better suit the application.

NOTE - It is not permissible to rotate the combustion air inducer on UHRS-030/105 and -175/400.

Rotate the combustion air inducer assembly as follows:

- 1 - Remove the heater from the carton. Decide the best unit heater orientation. The vent can be installed in one of three discharge positions: up, left, or right.
- 2 - If the inducer is to be rotated, follow the instructions in this section; otherwise, refer to instructions under "Venting" section.
- 3 - Before making an electrical or gas connections, use a socket to remove the four screws which secure the combustion air inducer to the flue box. See figure 3.
- 4 - Rotate the inducer 90° to the desired position. Reinsert and tighten the inducer securing screws.
- 5 - The unit heater is now ready for installation as described in the Venting section.

Venting

NOTE - The vent is a passageway, vertical or nearly so, used to convey flue gases from an appliance, or its vent connector, to the outside atmosphere. The vent connector is the pipe or duct that connects a fuel-gas-burning appliance to a vent or chimney.

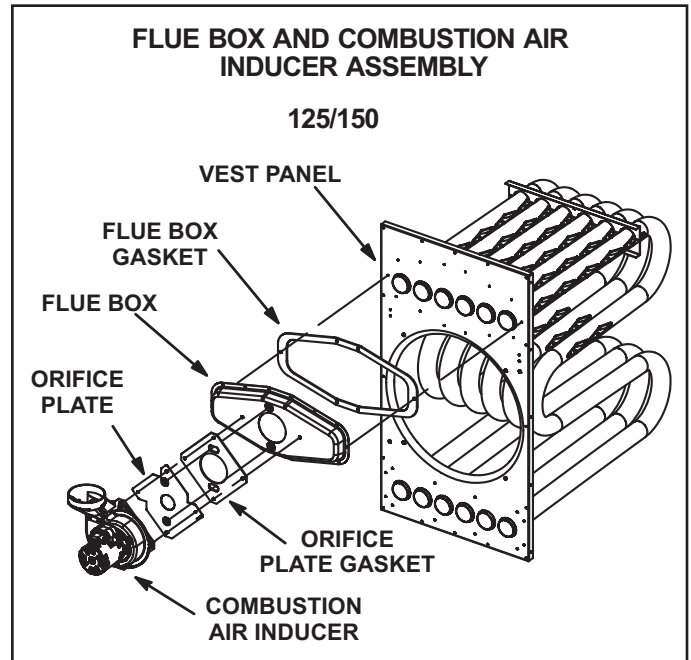

FIGURE 3

NOTE - Local codes may supersede any of these provisions.

GENERAL RECOMMENDATIONS AND REQUIREMENTS

Unit heaters must be vented in compliance with the latest edition of the National Fuel Gas Code (NFPA 54 / ANSI Z223.1) in the USA and with CSA-B149.1 codes in Canada, as well as applicable provisions of local building codes, and the following instructions.

Vent piping must be in compliance with UL 1738 for installations in the United States, and ULC S636 for installations in Canada. Refer to venting sections for vent termination clearance requirements.

Note - Different manufacturers have different joint systems and adhesives. Do not mix pipe, fittings or joining methods from different manufacturers.

030-150 Units - The transition is a part of the combustion air blower.

175-400 Units - A sheet metal transition is supplied with this certified unit. It must not be modified or altered and must be installed on the outlet of the combustion air inducer assembly prior to the installation of the vent connector. Failure to comply with this requirement will void the certification of the unit by the approval agencies.

A single-wall vent connector may be used between the furnace and the vertical vent pipe in all applications; however, **single-wall vent material cannot be used for vertical vent piping in residential applications. UL-approved Category III venting materials must be used in all residential applications which vent horizontally.**

A single-wall vent pipe used as a vent connector in residential or commercial applications, or as a vertical vent in commercial applications, must have all seams and joints sealed with pressure-sensitive aluminum tape or silicone rubber sealant. The aluminum tape must have a temperature rating of 400°F (204°C) i.e., 3M 433 or equivalent. Silicone rubber sealant must have a temperature rating of 482°F (250°C), i.e., Dow Corning RTV-736 or equivalent. All joints must be secured with at least two corrosion-resistant screws. All joints must be checked for gas tightness after installation. Single-wall vent pipe used as vertical vent in commercial applications must not pass through any attic, interior wall, concealed space, or floor.

VERTICAL VENTS USING METAL VENT PIPE - COMMERCIAL AND RESIDENTIAL INSTALLATIONS

These compact unit heaters are listed as Category 1 appliances for vertical vent installations.

- 1 - These unit heaters are to be used with NFPA- or ANSI-approved chimneys or U.L.-listed type B-1 gas vents, or listed chimney lining systems for gas venting where applicable, as well as the modifications and limitations listed in figure 3. Seal single-wall vent material according to **General Recommendations and Requirements** section.
- 2 - The vent connector shall be 4" (102mm) diameter on 30 , 45 , 60 , 75 , 090, 105 , 125 , and 150 Btuh units; 5" (127mm) diameter on 175 , 200 , 250 , & 300 Btuh units; 6" (152mm) on 360 & 400 Btuh units. On 175-400 units, a flue transition piece (supplied) is required to fit over the outlet of the induced draft assembly on the appliance.

NOTE - If needed, loosen the upper right two or three screws securing the combustion air blower. Slide the transition into place and secure loosened screws.

- 3 - Keep the vent connector runs as short as possible with a minimum number of elbows. Refer to the current edition of ANSI Z223.1 or CSA-B149 installation compliance codes for maximum vent and vent connector lengths.
- 4 - The entire length of a single-wall metal vent connector shall be readily accessible for inspection, cleaning and replacement.
- 5 - Single-wall vent pipe used as vertical vent in commercial applications must not pass through any attic, interior wall, concealed space, or floor.

**TABLE 3
MAXIMUM HORIZONTAL VENT CONNECTOR AND HORIZONTAL VENT PIPE LENGTHS**

No. of Elbows	30, 45, 60, 75, 90, 105, 125, 150, 175, 200, 350, 400		250 & 300	
	ft	m	ft	m
1	25	7.6	35	10.7
2	20	6.1	30	9.1
3	15	4.6	25	7.6
4	10	3.0	20	6.1
5	5	1.5	15	4.6
6	-	-	10	3.0
7	-	-	5	1.5

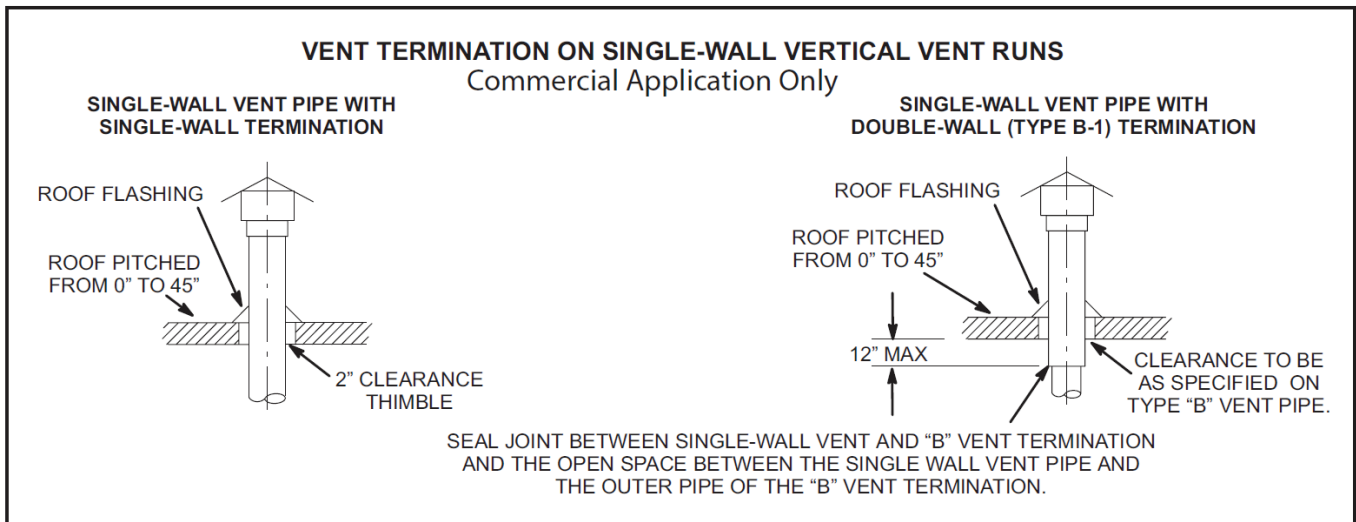

FIGURE 4

- 6 - The unit may be vented vertically as a single appliance or in a common vent with other gas-fired appliances. In common venting situations, vent connectors for other appliances must maintain a 4" (102mm) vertical separation between the vent connectors. Refer to common venting tables in the current editions of ANSI Z223.1 or CSA-B149 installation compliance codes for proper vent size.
- 7 - Clearance to combustible material is 6" (152mm) for single-wall vent material except where a listed clearance thimble is used. Clearance to combustible material for type B-1 vent or factory-built chimney is per manufacturer's instructions.
- 8 - The vent connector shall be supported without any dips or sags. Vertical vents shall be supported in accordance with their listing and manufacturers' instructions. All horizontal vent connector runs shall have a slope up to the vertical vent of at least 1/4" per foot (1mm per 50mm).
- 9 - All vertical type B-1 vents, single-wall vertical vents (commercial applications), or listed chimney lining systems must be terminated with a UL-listed (or other equivalent agency) vent cap or listed roof assembly.
- 10 - The vent must extend at least 3 feet (1m) above the highest point where it passes through a roof of a building. The vent must also extend at least 2 feet (1m) higher than any part of a building within a horizontal distance of 10 feet (3m) unless otherwise specified by ANSI Z223.1 or CSA-B149 installation compliance codes. The vent must extend at least 5 feet (2m) above the highest connected equipment flue collar
- 6 - Horizontal vent termination must be free from obstructions and at least 12" (305mm) above grade level and maximum snow height.
- 7 - Do not install a horizontal vent termination directly below roof eaves or above a public walkway, or any other area where condensate dripping may be troublesome and may cause some staining. Avoid windows where steam may cause fogging or ice buildup.
- 8 - Minimum clearance for horizontal vent termination from any door, window, non-mechanical air supply inlet is 4 feet below or to the side of opening; 1 foot above opening horizontally for United States installations. In Canada, minimum clearance for horizontal vent termination from any door, window, non-mechanical air supply inlet or the combustion air inlet to any other appliance is 12 inches for appliances 10,000 to 100,000 Btuh, and 36 inches for appliance 100,000 Btuh.

Refer to latest editions of the ANSI Z223.1 or CSA-B149 for installation compliance codes and with local authorities with jurisdiction.

- 9 - Vent terminal clearance to each side of a centerline extended above a meter/regulator assembly and service regulator vent outlet must be in accordance with local installation codes and the requirements of the gas supplier for installations in the United States. In Canada the clearance to each side of a centerline extended above meter/regulator assembly and service regulator vent outlet must be 3 feet(1m) within a height 15 feet above the meter/regulator assembly and 3 feet to a service regulator vent.
- 10 - Vent termination clearance to an unvented soffit or within 2 feet horizontally of a ventilated soffit must be in accordance with local installation codes and the requirements of the gas supplier.
- 11 - When a vent termination is inside a corner formed by two exterior walls the clearance must be in accordance with local installation codes and the requirements of the gas supplier.
- 12 - Vent termination must be a minimum of 3 feet(1m) above any forced air inlet (includes fresh air inlet for other appliance, such as a dryer) if within 10 feet horizontally for United States installations. In Canada, vent termination must have 6 feet (2m) minimum clearance to a mechanical air-supply inlet of any building.- All horizontal vents which use special vent pipe for use with Category III appliances must terminate with an approved Category III tee. Opening end must face downward.
- 13 - When termination is routed through combustible wall, vent termination must be supported using a firestop to maintain clearances specified on unit rating plate. Inside edge of vent termination must be at least 16" (406mm) from outside wall.
- 14 - All horizontal vents which use special vent pipe for use with Category III appliances must terminate with an approved Category III tee. Opening end must face downward.
- 15 For horizontal venting, the vent pipe shall be supported with hangers no more than 3 feet. (1m)

HORIZONTAL VENTING

NOTE - Common venting is not allowed when horizontally venting the unit heater.

NOTE - Precautions must be taken to prevent degradation of building materials by flue products.

If the UH(RS,CM) unit heater is to be horizontally vented, a positive pressure may be created in the vent. The unit heater, when installed with horizontal venting, will perform as a category III appliance.

- 1 - In residential applications which vent horizontally, use only special vent materials approved for use with Category III appliances.
- 2 - The vent pipe diameter for horizontal installations shall be 4" (102mm) diameter on 30 , 45 , 60 , 75 , 90, 105 , 125 , and 150 Btuh units; 5" (127mm) diameter on 175 , 200 , 250 , & 300 Btuh units; 6" (152mm) on 350 & 400 Btuh units. On 175-400 units, a flue transition piece (supplied) is required to fit over the outlet of the induced draft assembly on the appliance.
- 3 - The minimum horizontal vent length is 5 feet (2m).
- 4 - Refer to table 3 for maximum horizontal vent lengths.
- 5 - If possible, do not terminate the horizontal vent through a wall that is exposed to prevailing wind. Exposure to excessive winds can affect unit performance. If such a termination is necessary, use a wind block to protect the vent termination from direct winds.

apart to prevent movement after installation.

- 16 - Select a wall termination point that will maintain 1/4" (6mm) rise per foot (305mm) slope of horizontal run of vent pipe.
- 17 - For upward sloped vent, a condensate tee and drain must be installed within the first 5 feet (2m) from the unit heater to protect the appliance. If a flexible condensate drain line is used, the drain line must include a loop filled with water to prevent combustion products from entering the structure. If the unit is shut down for an extended period of time and will be exposed to sub-freezing temperatures, the condensate may freeze.
- 18 - Select a wall termination point that will maintain 1/4" rise per foot slope of horizontal run of vent pipe. In areas where authorities having jurisdiction permit, a downward slope of maximum 1/4" per foot is also acceptable. Condensate drainage can be collected in a tee pipe section (figure 4) with drain loop similar to one used for upward slope vent, or allowed to drip through the vent termination, if permitted by authorities (figure 6).

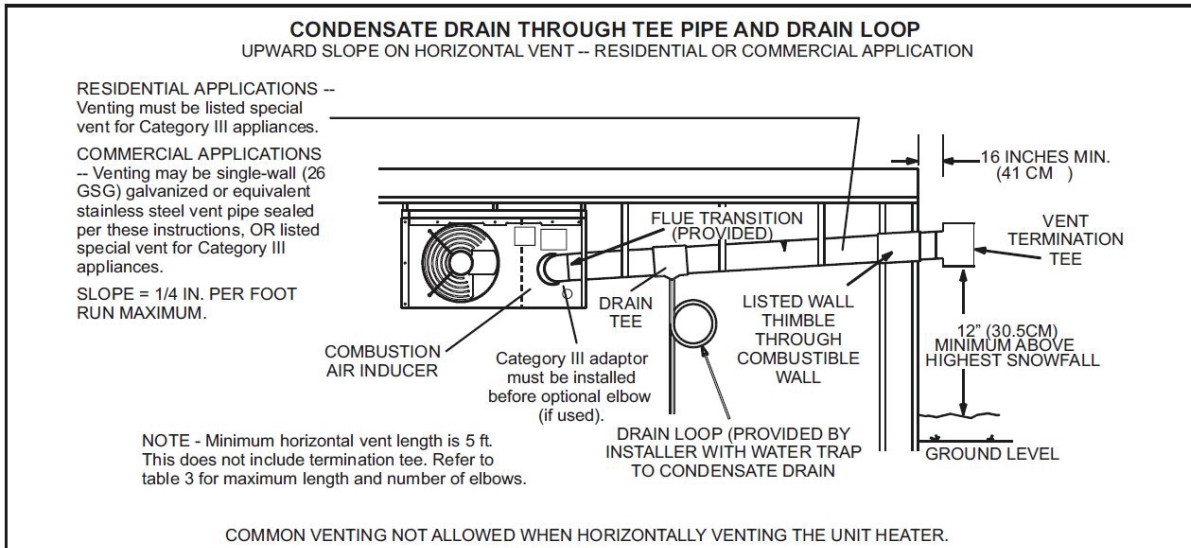

FIGURE 5

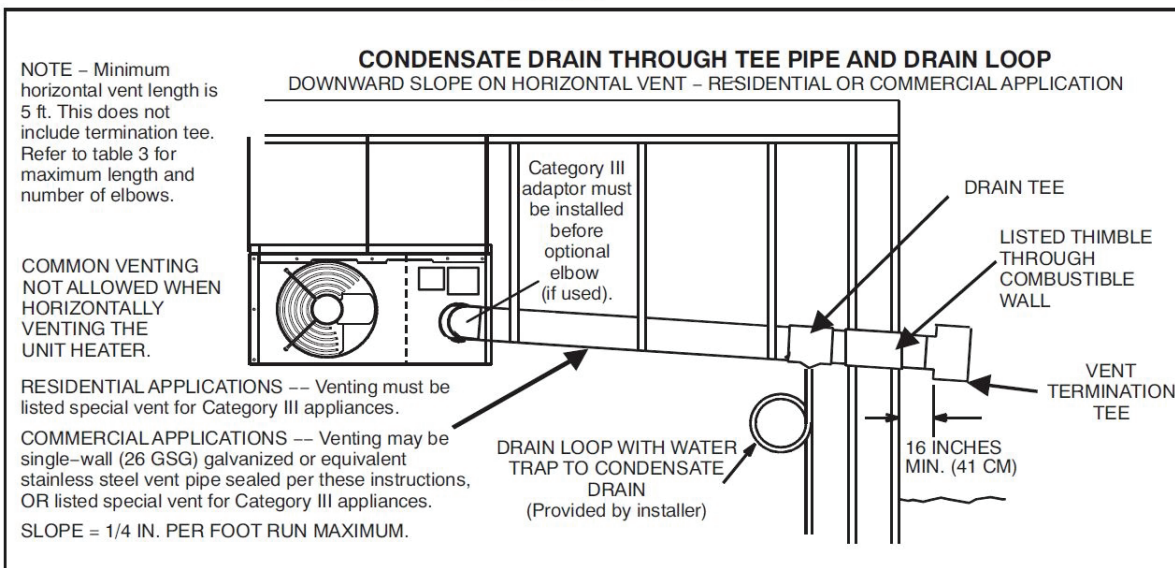

FIGURE 6

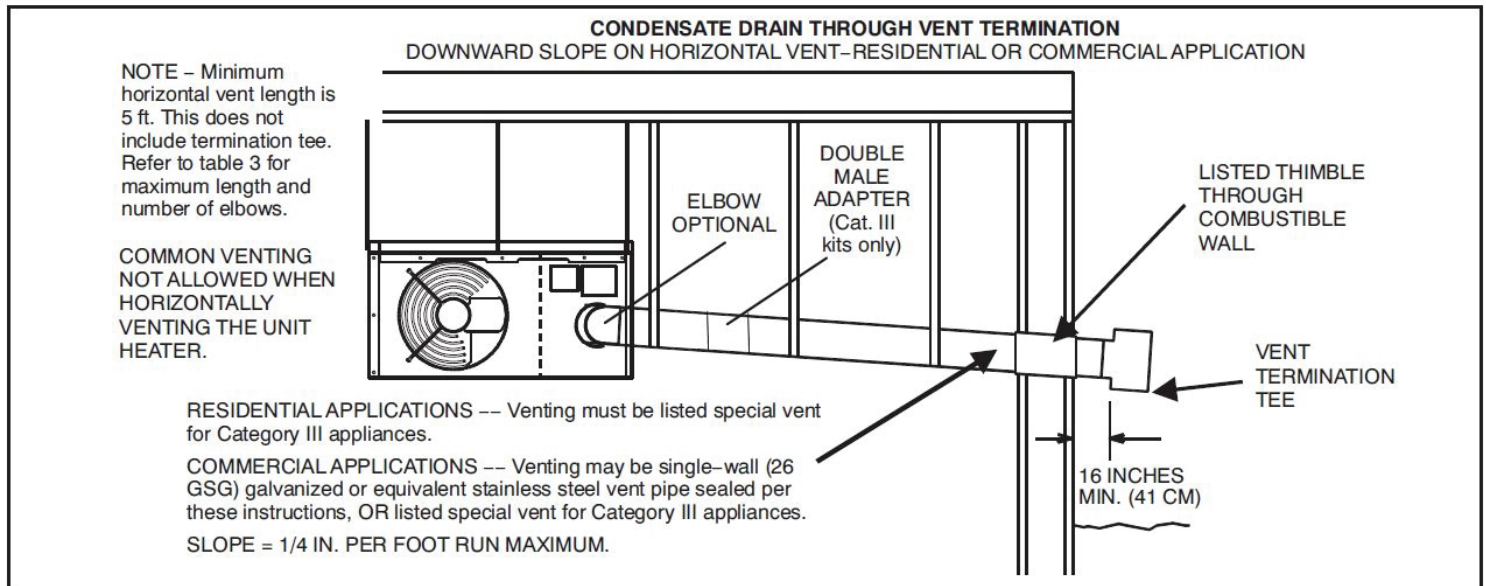

FIGURE 7

VENTING USING A MASONRY CHIMNEY

The following additional requirements apply when a lined masonry chimney is being used to vent the compact unit heater.

! IMPORTANT

Single appliance venting of a fan-assisted unit heater into a tile lined masonry chimney (interior or outside wall) is prohibited. The chimney must first be lined with either type "B-1" vent or an insulated single-wall flexible vent lining system, sized in accordance with venting tables in the ANSI Z223.1, or CSA-B149 installation compliance codes.

- 1 - Masonry chimneys used to vent Category I units heaters must be either tile-lined or lined with a listed metal lining system or dedicated gas vent. Unlined masonry chimneys are prohibited. A category I appliance must never be connected to a chimney that is servicing a solid fuel appliance. If a fireplace chimney flue is used to vent this appliance, the fireplace opening must be permanently sealed.

- 2 - A fan-assisted unit heater may be commonly vented into an existing lined masonry chimney provided:
 - a. The chimney is currently serving at least one draft-hood equipped appliance.
 - b. The vent connector and chimney are sized in accordance with venting tables.

- 3 - A "B1" double-wall vent or masonry chimney liner shall terminate above the roof surface with a listed cap or a listed roof assembly in accordance with the terms of their respective listings and the vent manufacturer's instructions.

- 4 - Do not install a manual damper, barometric draft regulator, or flue restrictor between the unit heater and the chimney.

- 5 - If type "B1" double-wall vent is used inside a chimney, no other appliance can be vented into the chimney. Outer wall of type "B" vent pipe must not be exposed to flue products.

- 6 - Insulation for the flexible vent pipe must be an encapsulated fiberglass sleeve recommended by the flexible vent pipe manufacturer.

- 7 - The space between liner and chimney wall should NOT be insulated with puffed mica or any other loose granular insulating material.

8. - If B-1 vent or an insulated flexible vent pipe cannot be used as liners, the chimney must be rebuilt to accommodate one of these methods or some alternate approved method must be found to vent the appliance. When inspection reveals that an existing chimney is not safe for the intended purpose, it shall be rebuilt to conform to nationally recognized standards, lined or relined with suitable materials or replaced with a gas vent or chimney suitable for venting unit heaters. The chimney passageway must be checked periodically to ensure that it is clear and free of obstructions.

2 REMOVAL OF UNIT FROM COMMON VENT

In the event that an existing unit heater is removed from a venting system commonly run with separate gas appliances, the venting system is likely to be too large to properly vent the remaining attached appliances. The following test should be conducted while each appliance is in operation and the other appliances are not in operation, yet remain connected to the common venting system. If the venting system has been installed improperly, the system must be corrected.

- 1 - Seal any unused openings in the common venting system.
- 2 - Visually inspect the venting system for proper size and horizontal pitch. Determine there is no blockage or restriction, leakage, corrosion, or other deficiencies which could cause an unsafe condition.
- 3 - In so far as is practical, close all building doors and windows and all doors between the space in which the appliances remaining connected to the common venting system are located and other spaces of the building. Turn on clothes dryers and any appliances not connected to the common venting system. Turn on any exhaust fans, such as range hoods and bathroom exhausts, so they will operate at maximum speed. Do not operate a summer exhaust fan. Close fireplace dampers.
- 4 - Follow the lighting instructions. Place the appliance being inspected in operation. Adjust thermostat so appliance will operate continuously.
- 5 - Test for spillage at the draft hood relief opening after five minutes of main burner operation. Use the flame of a match or candle, or smoke from a cigarette, cigar, or pipe.
- 6 - After it has been determined that each appliance remaining connected to the common venting system properly vents when tested as outlined above, return doors, windows, exhaust fans, fireplace dampers and any other gas-burning appliance to their previous condition of use.
- 7 - If improper venting is observed during any of the above tests, the common venting system must be corrected. The common venting system should be resized to approach the minimum size as determined by using the appropriate tables in Appendix G in the current editions of the ANSI Z223-1, or the appropriate Category I Natural Gas and Propane appliances venting sizing tables in the current standards of the CSA-B149 for installation compliance codes.

Electrical Connections

NOTE - Local codes may supersede any of the provisions outlined in this instruction.

These unit heaters use a direct spark ignition system. There is no pilot necessary as the spark lights the main burner when the gas valve is turned on. The direct spark ignition control board (A3) emits radio noise as the sparking process is under way. The level of energy may be sufficient to disturb a logic circuit in a microprocessor controlled thermostat. It is recommended that an isolation relay be used when connecting the unit heaters to a microprocessor controlled thermostat.

250-400 Units Only: Units are shipped from the factory in two-stage heating mode. When using a single-stage thermostat or control, jumper W1 & W2 terminals on P367 5-pin thermostat plug.

Install the thermostat according to instructions provided. Route thermostat wiring through knockout on the power entry box located on the side of the unit heater. Refer to dimensions in the front of this instruction for location. Use 18 gauge wire or larger for thermostat connections.

Connect thermostat wires to 5-pin P367 thermostat plug located on the A3 ignition control board. See figure 7. For ease of installation, disconnect P367 plug from J367, make wire connections, and replace P367. Refer to diagram on unit and appropriate diagram in this instruction.

An additional thermostat wire must be run to terminal "G" on heater when continuous blower is desired.

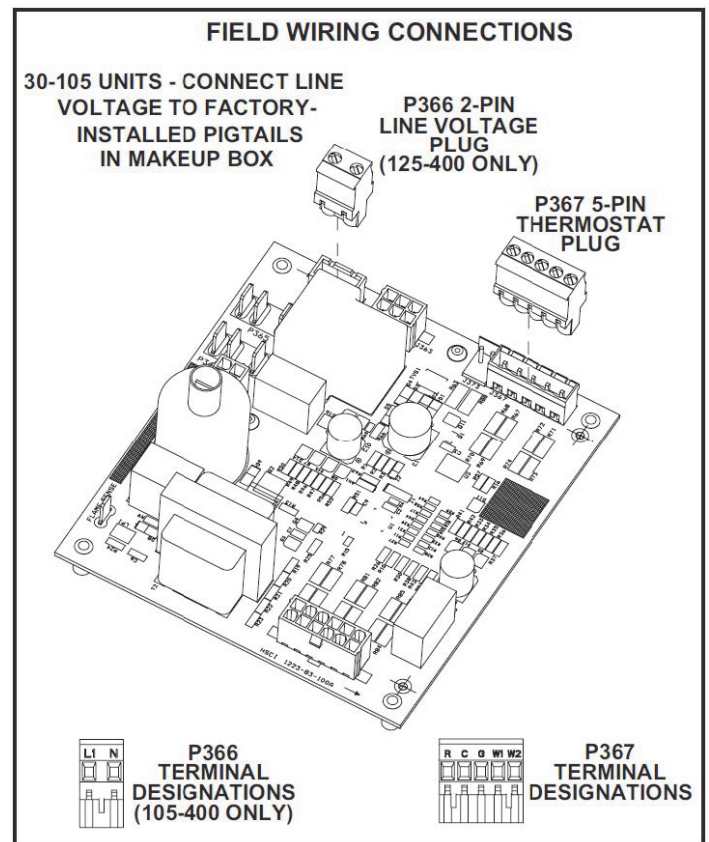

FIGURE 8

LINE VOLTAGE WIRING

1 - Install a separate fused disconnect switch with the fuse sized according to the blower motor size.

NOTE - Electrically ground unit in accordance with local codes or, in the absence of local codes, in accordance with the current editions of the ANSI/NFPA No. 70, National Electrical Code or CSA C22.1, Canadian Electrical Code, Part 1.

NOTE - Uninsulated ground wires must be wrapped in electrical tape to avoid damage to the electrical system.

2 - Make line voltage connections as shown in figure 8. On 030-105 units, use pigtailed provided in power entry box. On 125-400 units, connect wires to 2-pin P366 plug located on the A3 ignition control board. For ease of installation, disconnect P366 plug from J366, make wire connections, and replace P366. Refer to wiring diagram on unit and the appropriate typical diagram in this manual.

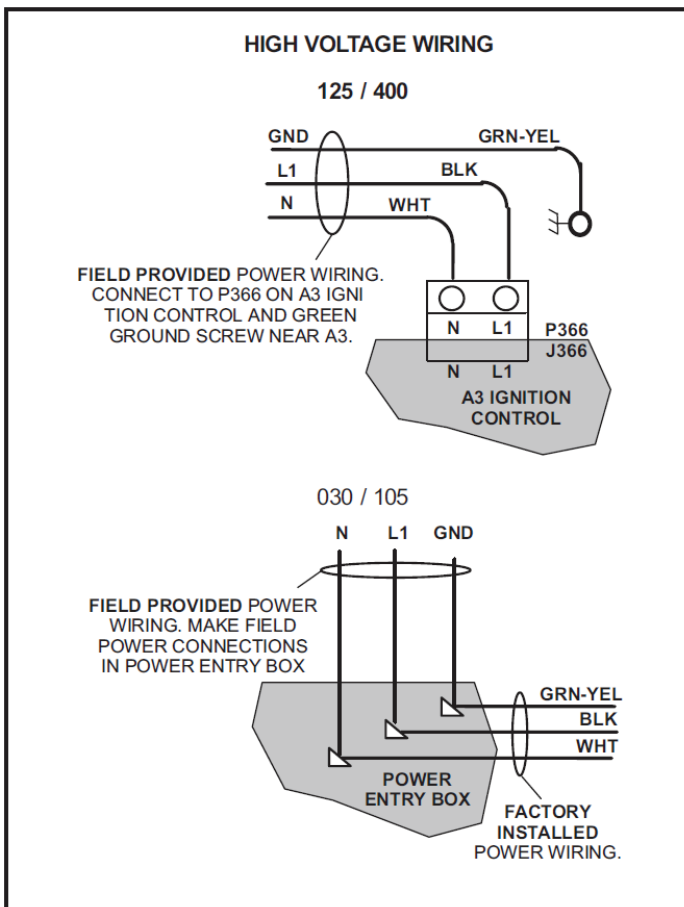



537992-02

AA

BB

CC

DD

EE

FF

01

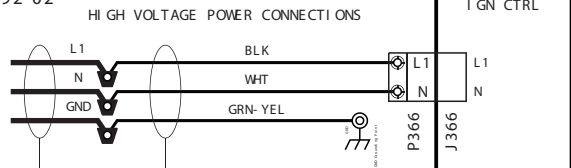

02

FIELD PROVIDED POWER WIRING MAKE FIELD POWER CONNECTIONS IN POWER ENTRY BOX.

FACTORY INSTALLED POWER WIRING

03

EQUIPMENT GROUND

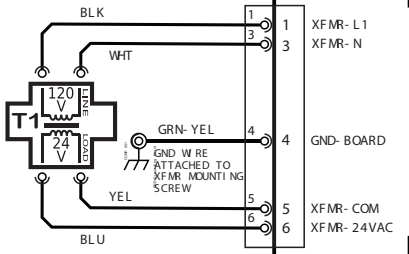

04

LOW VOLTAGE THERMOSTAT CONNECTIONS

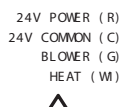

05

SET THERMOSTAT HEAT ANTICIPATION AS FOLLOWS
 HONEYWELL VALVE: .7
 WHITE ROGERS VALVE: .5

WARNING

DISCONNECT ALL POWER BEFORE SERVICING. ELECTRIC SHOCK HAZARD, CAN CAUSE INJURY OR DEATH. UNIT MUST BE GROUNDED IN ACCORDANCE WITH NATIONAL AND LOCAL CODES.

FOR USE WITH COPPER CONDUCTORS ONLY. REFER TO UNIT RATING PLATE FOR MINIMUM CIRCUIT AMPACITY AND MAXIMUM OVERCURRENT PROTECTION SIZE.

IF ANY WIRE IN THIS APPLIANCE IS REPLACED, IT MUST BE REPLACED WITH WIRE OF LIKE SIZE, RATING AND INSULATION THICKNESS.

07

NOTES		⚠
MAXIMUM LOAD NOT TO EXCEED 20VA AT 24VAC, CLASS 2.		1
S43 MAY BE FIELD OR FACTORY INSTALLED ON LP GAS UNITS ONLY.		2

08

Model:	UHRS Unit Heater; UHSC Separated Combustion Unit Heater		
	Heat Input - 030k-105k BTUH		
Voltage:	120/60/1		
Supersedes:	537992-01	Form No:	537992-02
		Rev:	0.0

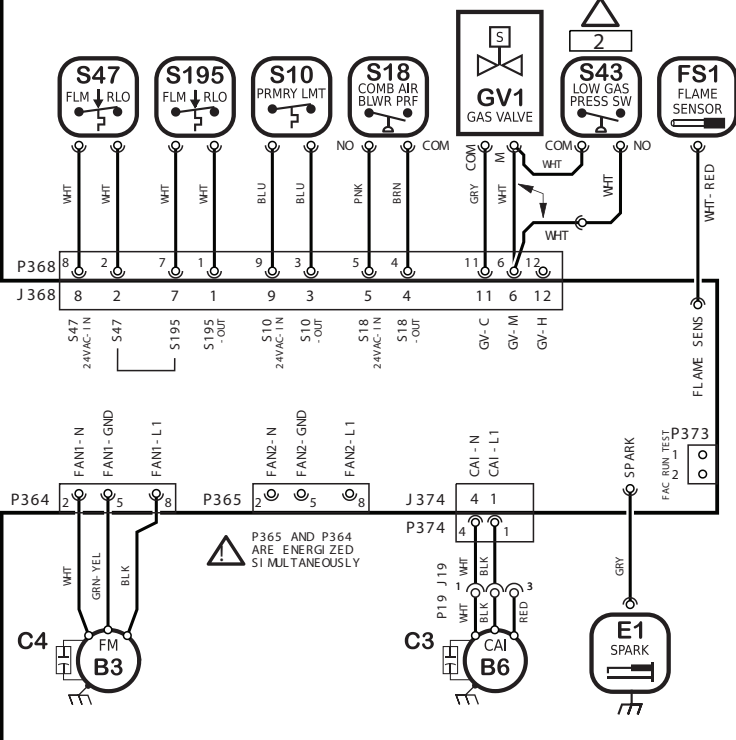

KEY LIST

LOCATION	COMPONENT TAG	COMPONENT DESCRIPTION
CONTROL		
CC01	A3	IGN CTRL CONTROL, BURNER
POWER		
BB03	T1	TRANSFORMER, CONTROL
INPUT		
FF01	FS1	FLAME SENSOR, FLAME
DD01	S10	PRMRY LMT LIMIT, PRIMARY, GAS
EE01	S18	COMB AIR BLWR PRF SWITCH, COMBUSTION AIR BLOWER PROOFING
DD01	S47	FLM RLO SWITCH, FLAME ROLLOUT 1, BURNER 1
DD01	S195	FLM RLO SWITCH, FLAME ROLLOUT 2, BURNER 1
OUTPUT		
DD04	B3	FM MOTOR, FAN
EE04	B6	CAI MOTOR, COMBUSTION AIR, INDUCER
EE04	C3	- CAPACITOR, MOTOR, CAI
DD04	C4	- CAPACITOR, MOTOR, FAN
FF04	E1	SPARK IGNITER, SPARK
FF01	GV1	GAS VALVE VALVE, GAS
FF01	S43	LOW GAS PRESS SW LOW GAS PRESSURE SWITCH, GV1

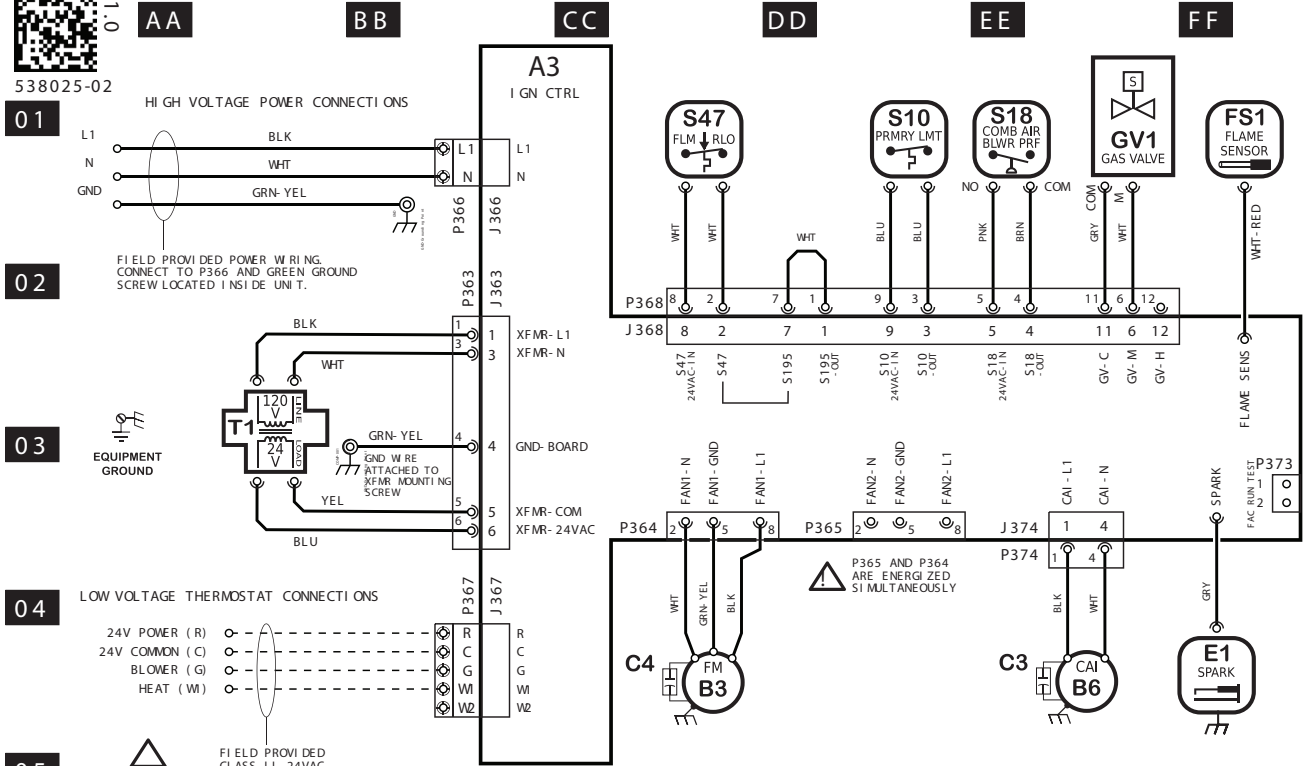

01 HIGH VOLTAGE POWER CONNECTIONS

02 FIELD PROVIDED POWER WIRING. CONNECT TO P366 AND GREEN GROUND SCREW LOCATED INSIDE UNIT.

03 EQUIPMENT GROUND

04 LOW VOLTAGE THERMOSTAT CONNECTIONS

05 SET THERMOSTAT HEAT ANTICIPATION AS FOLLOWS
HONEYWELL VALVE: .7
WHITE ROGERS VALVE: .5

WARNING

DISCONNECT ALL POWER BEFORE SERVICING. ELECTRIC SHOCK HAZARD, CAN CAUSE INJURY OR DEATH. UNIT MUST BE GROUNDED IN ACCORDANCE WITH NATIONAL AND LOCAL CODES.

FOR USE WITH COPPER CONDUCTORS ONLY. REFER TO UNIT RATING PLATE FOR MINIMUM CIRCUIT AMPACITY AND MAXIMUM OVERCURRENT PROTECTION SIZE.

IF ANY WIRE IN THIS APPLIANCE IS REPLACED, IT MUST BE REPLACED WITH WIRE OF LIKE SIZE, RATING AND INSULATION THICKNESS.

NOTES	
MAXIMUM LOAD NOT TO EXCEED 20VA AT 24VAC, CLASS 2.	1

KEY LIST		
LOCATION	COMPONENT TAG	COMPONENT DESCRIPTION
CONTROL		
CC01	A3 IGN CTRL	CONTROL, BURNER
POWER		
BB03	T1	TRANSFORMER, CONTROL
INPUT		
FF01	FS1	FLAME SENSOR
DD01	S10	PRMRY LMT
EE01	S18	COMB AIR BLWR PRF
DD01	S47	FLM RLO
OUTPUT		
DD04	B3	FM
EE04	B6	CAI
EE04	C3	-
DD04	C4	-
FF04	E1	SPARK
FF01	GV1	GAS VALVE

08 Model:	UHCM Unit Heater; UHSC Separated Combustion Unit Heater				
	Heat Input - 125k-200k BTUH				
Voltage:	120/60/1				
Supersedes:	538025-01	Form No:	538025-02	Rev:	1.0

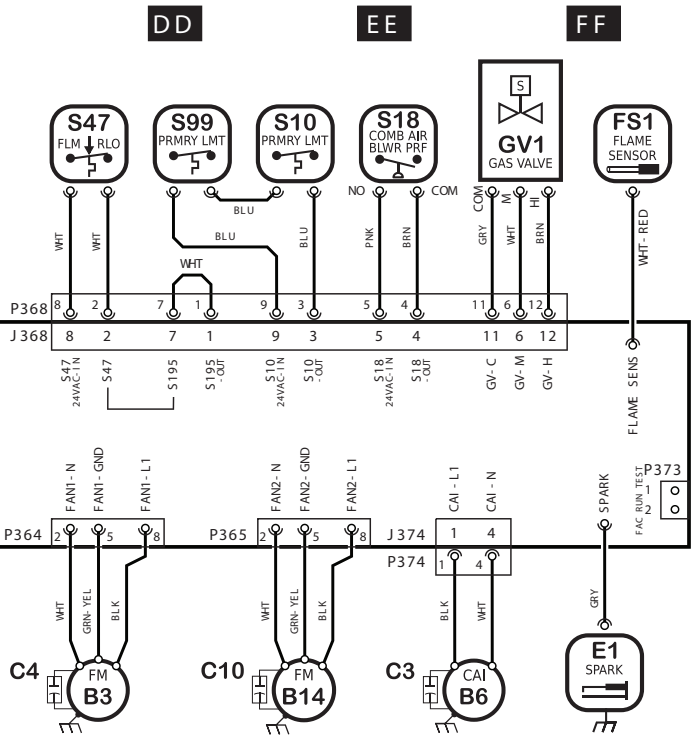
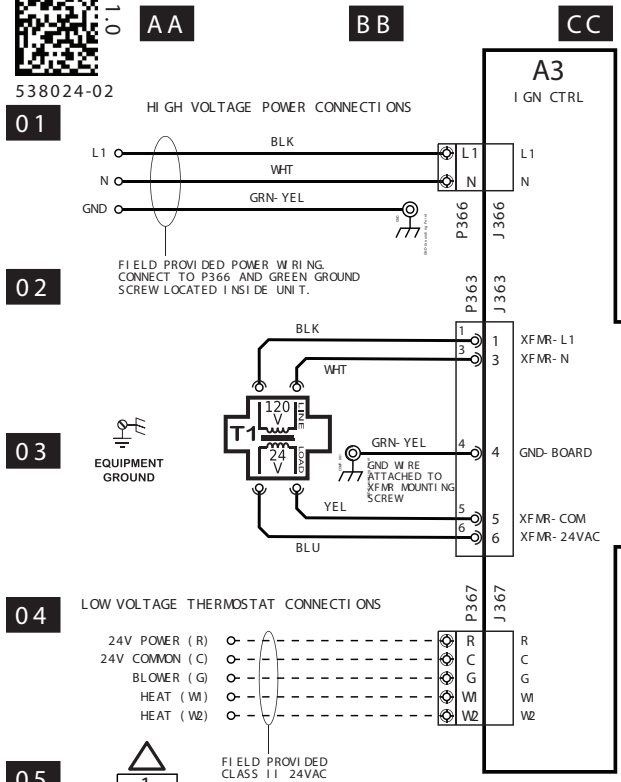

SET THERMOSTAT HEAT ANTICIPATION AS FOLLOWS
 HONEYWELL VALVE: .7
 WHITE ROGERS VALVE: .5

WARNING

DISCONNECT ALL POWER BEFORE SERVICING. ELECTRIC SHOCK HAZARD, CAN CAUSE INJURY OR DEATH. UNIT MUST BE GROUNDED IN ACCORDANCE WITH NATIONAL AND LOCAL CODES.

FOR USE WITH COPPER CONDUCTORS ONLY. REFER TO UNIT RATING PLATE FOR MINIMUM CIRCUIT AMPACITY AND MAXIMUM OVERCURRENT PROTECTION SIZE.

IF ANY WIRE IN THIS APPLIANCE IS REPLACED, IT MUST BE REPLACED WITH WIRE OF LIKE SIZE, RATING AND INSULATION THICKNESS.

NOTES	
MAXIMUM LOAD NOT TO EXCEED 20VA AT 24VAC, CLASS 2.	1

LOCATION	COMPONENT TAG	COMPONENT DESCRIPTION
CONTROL		
CC01	A3 IGN CTRL	CONTROL, BURNER
POWER		
BB03	T1 --	TRANSFORMER, CONTROL
INPUT		
FF01	FS1 FLAME SENSOR	SENSOR, FLAME
DD01	S10 PRMRY LMT	LIMIT, PRIMARY 1, GAS
EE01	S18 COMB AIR BLWR PRF	SWITCH, COMBUSTION AIR BLOWER PROOFING
DD01	S47 FLM RLO	SWITCH, FLAME ROLLOUT
DD01	S99 PRMRY LMT	LIMIT, PRIMARY 2, GAS
OUTPUT		
DD04	B3 FM	MOTOR, FAN 1
EE04	B6 CAI	MOTOR, COMBUSTION AIR, INDUCER
DD04	B14 FM	MOTOR, FAN 2
EE04	C3 --	CAPACITOR, MOTOR, CAI
DD04	C4 --	CAPACITOR, MOTOR, FAN 1
DD04	C10 --	CAPACITOR, MOTOR, FAN 2
FF04	E1 SPARK	IGNITER, SPARK
FF01	GV1 GAS VALVE	VALVE, GAS

08	Model:	UHCM Unit Heater; UHSC Separated Combustion Unit Heater		
		Heat Input - 250k-400k BTUH		
	Voltage:	120/60/1		
	Supersedes:	538024-01	Form No:	538024-02
			Rev:	1.0

Gas Connection

Note - Install protective bushing (provided in bag assembly) before making gas connections.

When connecting gas supply, the length of the run from the meter must be considered in determining the pipe size to avoid excessive pressure drop. A line pressure of 7" w.g. (178mm w.g.) for natural gas should be maintained when sizing piping. For correct sizing of piping, consult the utility having jurisdiction.

A drip leg should be installed in the vertical pipe run to the unit. In some localities, codes may require that a manual main shutoff valve and union (furnished by installer) be installed external to the unit. Union must be of the ground joint type. A drip leg should be readily accessible to permit cleaning and emptying. See figure 10.

NOTE - If a switch box is mounted over electrical knock-outs on back of unit, leave a minimum of 4" (102mm) clearance between switch box and drip leg.

A 1/8" NPT plugged tap shall be installed immediately upstream of the gas supply connection to the heater.

NOTE - Compounds used on threaded joints of gas piping must be resistant to the actions of liquefied petroleum gases.

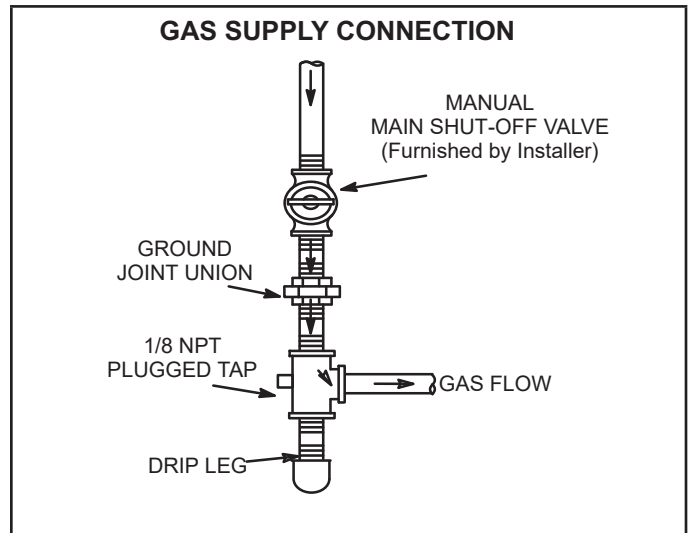

FIGURE 10

Leak Check

After gas piping is completed, carefully check all piping connections, (field and factory), for gas leaks. Use a soap solution or other preferred means.

CAUTION

DO NOT use matches, candles, flame or other sources of ignition to check for gas leaks.

The appliance must be isolated from the gas supply piping system by closing its individual manual gas shutoff valve during any pressure testing of the gas supply system at test pressures equal to or greater than 1/2 psig (3.45kPa).

IMPORTANT

The heater and its individual shut off valve must be disconnected from the gas supply piping system during any pressure testing of that system at test pressures in excess of 1/2 psig (3.45kPa). See figure 9.

NOTE - In case emergency shutdown is required, shut down main gas valve and disconnect main power to unit. These devices should be properly labeled by the installer.

Unit Start-Up

FOR YOUR SAFETY READ BEFORE LIGHTING

WARNING



Electric shock hazard. Can cause injury or death. Do not use this unit if any part has been under water. Immediately call a qualified service technician to inspect the unit and to replace any part of the control system and any gas control which has been under water.

WARNING

Install, operate and maintain unit in accordance with manufacturer's instructions to avoid exposure to fuel substances or substances from incomplete combustion which can cause death or serious illness.

WARNING



Danger of explosion. Can cause injury or product or property damage. If overheating occurs or if gas supply fails to shut off, shut off the manual gas valve to the appliance before shutting off electrical supply.

Oil residues, from manufacturing of the heat exchanger, may cause the unit to produce smoke when first started; there is no health hazard associated with this. As a precaution, open doors and windows and alert people in the building there may be smoke on start-up.

Return Air Temperature Requirements:

The following return air temperatures must be maintained for optimum unit operation and extended life of the heat exchanger. Failure to comply with the conditions will void the warranty.

Minimum return air temperature for units built with aluminized steel heat exchanger: 55°F

Minimum return air temperature for units built with stainless steel heat exchanger: 45°F

Maximum return air temperature: 85°F

WARNING



Electric shock hazard. Can cause injury or death. Before attempting to perform any service or maintenance, turn the electrical power to unit OFF at disconnect switch(es). Unit may have multiple power supplies.

WARNING



Danger of explosion. Can cause injury or product or property damage. You must follow these instructions exactly.

BEFORE LIGHTING smell all around the appliance area for gas. Be sure to smell next to the floor because some gas is heavier than air and will settle on the floor.

Use only your hand to move the switch. Never use tools. If the switch will not move by hand, do not try to repair it, call a qualified service technician. Force or attempted repair may result in a fire or explosion.

OPERATION OF WHITE RODGERS 36H SERIES VALVE (FIGURE 11) AND WHITE RODGERS 36G SERIES GAS VALVE (FIGURE 12)

NOTE - **STOP!** Read the safety information at the beginning of this section.

- 1 - Set thermostat to lowest setting.
- 2 - Turn off all electrical power to appliance.
- 3 - This appliance is equipped with an ignition device which automatically lights burners. **DO NOT attempt to light the burners manually.**
- 4 - Move switch to OFF.
- 5 - Wait five minutes to clear out any gas. If you then smell gas, **STOP!** Immediately call your gas supplier from a neighbor's phone. Follow the gas supplier's instructions. If you do not smell gas, go to next step.
- 6 - Move switch to **ON**.
- 7 - Turn on all electric power to unit.
- 8 - Set thermostat to desired setting.
- 9 - If appliance still will not operate, follow the instructions **"To Turn Off Gas to Unit"** and call your service technician or gas supplier.

To Turn Off Gas to Unit

- 1 - Set thermostat to lowest level.
- 2 - Turn off all electrical power to unit if service is to be performed.
- 3 - Move switch to OFF

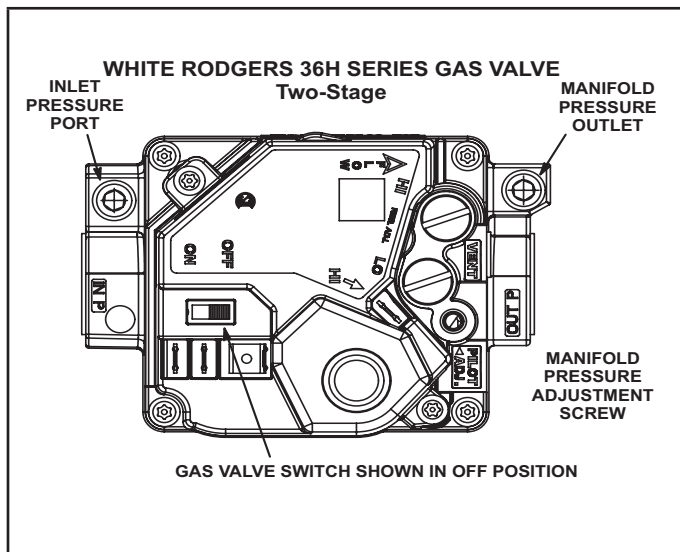

FIGURE 11

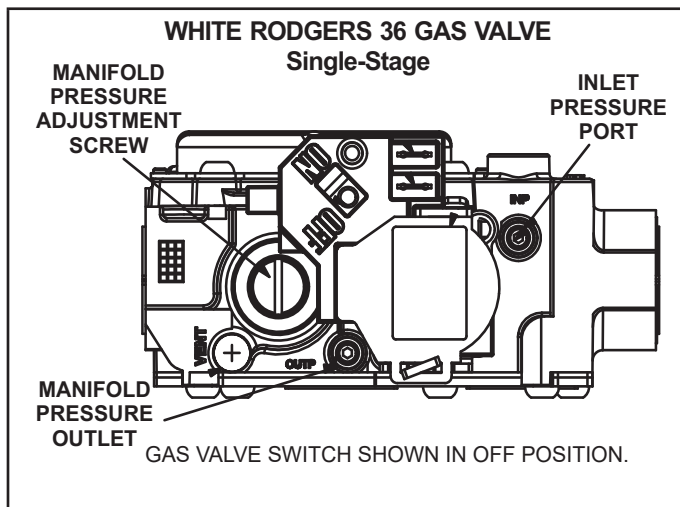

FIGURE 12

Heating Sequence of Operation

- 1 - When the thermostat calls for heat, the combustion air inducer starts immediately.
- 2 - Combustion air pressure switch proves inducer operation before allowing ignition sequence to start. This switch is factory set and no adjustment is necessary.
- 3 - After pre-purge of approximately 30 seconds, the spark ignition is energized and the solenoid valves open in the gas valve.
- 4 - The spark then ignites the gas, the ignition sensor proves the flame and the combustion process continues.
- 5 - In the event that the flame is not detected after the first 10-second trial for ignition, the controller will repeat steps 3 and 4 an additional two times before locking out the gas valve. Ignition control will then automatically repeat steps 3, 4, and 5 after 60 minutes.

NOTE - To interrupt the 60-minute lockout period, move thermostat from "Heat" to "OFF" then back to "Heat." Heating sequence then restarts at step 1.

- 6 - The burners must light without noticeable crossover delay. There must be no flame lifting from the burner heads, flashback or burning within the burner. The flames should be predominantly blue in color and should be approximately centered in the tubes with no apparent impingement taking place.
- 7 - The ignition control will energize the fan approximately 30 seconds after ignition is established.
- 8 - After the thermostat demand is satisfied the gas valve is closed. Thirty seconds after the demand is satisfied, the combustion air inducer is shut off.
- 9 - The ignition control will shut off the system fan approximately 150 seconds after the gas valve is de-energize.

Gas Flow

To check for proper gas flow to the combustion chamber, determine the Btu input from the appliance rating plate. Divide this input rating by the Btu per cubic feet of available gas. Result is the required number of cubic feet per hour. Determine the flow of gas through the gas meter for two minutes and multiply by 30 to get the hourly flow of gas.

Gas Pressure Adjustment

- 1 - Check gas line pressure with unit firing at maximum rate. A minimum of the following should be maintained for proper unit operation:

- 030-105KBTUH** - 5" (127mm) w.c. for natural gas
 - 125-400KBTUH** - 6" (152mm) w.c. for natural gas
 - 030-105KBTUH** - 10.5" (267mm) w.c. for LP/propane gas
 - 125-400KBTUH** - 11.0" (279mm) w.c. for LP/propane gas
- NOTE** - Maximum line pressure shall not exceed 13" w.c. for natural and propane gases.

- 2 - After line pressure has been checked and adjusted, check regulator pressure. Correct manifold pressure is shown on the unit rating plate. See figures 11 and 12 for gas pressure adjustment screw location. A natural gas to LP/propane gas changeover kit is required to convert the unit in the field. Refer to installation instructions provided with changeover kit for conversion procedure.

Ignition Control LED

The ignition control contains a green LED which indicates the following:

**TABLE 4
IGNITION CONTROL LED**

LED	UNIT OPERATION
Slow Flash*	Normal Operation - No call for heat
Fast Flash	Normal Operation - Call for heat
2 Flashes	System lockout - failed to detect or sustain flame
3 Flashes	Pressure switch failed closed before CAI is energized or failed open after CAI is energized
4 Flashes	High limit (S10) switch open
5 Flashes	Flame sensed and gas valve (GV1) not energized
6 Flashes	On-board microprocessor fault.
7 Flashes	Pressure switch (S18) closed with inducer off.
8 Flashes	Rollout switch (S47/S195) open. Cycle-power to reset.
Steady On	Control board (A3) failure
Steady Off	Internal control board (A3) failure or not power.

High Altitude Adjustments

In Canada, certification for installation at altitudes over 4500 feet (1372m) above sea level is the jurisdiction of local authorities. ADP recommends derating 4 /1000 feet above 4,500 feet. Refer to table 6 for natural gas manifold pressures and the Engineering Handbook for high altitude kit part numbers.

Units may be fired at full input up to 2000 feet. (610m) above sea level. Above 2000 feet (610m), manifold pressure must be adjusted. Adjust pressure regulator to pressure shown in table 5.

**TABLE 5
CANADA - NATURAL GAS MANIFOLD PRESSURES
[inch w.g. (kPa)]**

MODEL	Altitude in Feet (Meters)					
	0-2000 (0-610)	2001-4500 (610-1372)	4501-5500 (1372-1676)	5501-6500 (1677-2012)	6501-7500 (2012-2286)	7501-9500 (2286-2896)
030, 045, 060, 075, 090, 105	3.5 (0.87)	3.3 (0.82)	3.0 (0.75)	2.8 (0.70)	2.5 (0.62)	See Kit Instruction
125, 150, 175, 200	3.5 (0.87)	3.1 (0.77)	2.8 (0.70)	2.6 (0.65)	See Kit Instruction	
250, 300, 350, 400	3.7 (0.92)	3.2 (0.80)	2.9 (0.72)	2.8 (0.70)	2.6 (0.65)	See Kit Instruction
250, 300, 350, 400	3.7* (0.92)	3.3* (0.82)	2.9* (0.72)	2.8* (0.70)	2.6* (0.65)	See Kit Instruction
1.6** (0.40)						

* High Fire **Low Fire

In the US, units may be fired at full input up to 2000 feet (610m) above sea level. Above 2000 feet (610m), unit must be de-rated by four percent per 1000 feet for installation above 2000 feet. The de-rate may be accomplished by adjusting the manifold pressure. See table 8 for NG & table 8 for LP gas manifold pressures. See the Engineering Handbook for high altitude kit part numbers.

TABLE 6

CANADA - PROPANE GAS MANIFOLD PRESSURES [inch w.g. (kPa)]							
MODEL	Altitude in Feet (Meters)						
	0-2000 (0-610)	2001-4500 (610-1372)	4501-5500 (1372-1677)	5501-6500 (1677-1982)	6501-7500 (1982-2287)	7501-8500 (2287-2591)	8501-9500 (2592-2896)
030, 045, 060, 075, 090, 105	10.0 (2.49)	9.0 (2.24)	8.4 (2.09)	7.8 (1.94)	7.3 (1.82)	See Kit Instruction	
125, 150, 175, 200	10.0 (2.49)	9.1 (2.26)	8.5 (2.12)	7.8 (1.94)	7.2 (1.79)	See Kit Instruction	
250, 300, 350, 400	10.5 (2.61)	8.5 (2.12)	See Kit Instruction				

NOTE - A LP/propane to natural gas changeover kit is required to convert the unit in the field. Refer to the installation instructions supplied with the changeover kit for

TABLE 7

**US - NATURAL GAS MANIFOLD PRESSURES
[inch w.g. (kPa)]**

MODEL	Altitude in Feet (Meters)				
	0-2000 (0-610)	2001-3000 (610- 914)	3001-4000 (915- 1219)	4001-5000 (1220-1524)	5001-10000 (1524-3048)
030, 045, 060, 075, 090, 105	3.5 (0.87)	3.1 (0.77)	2.9 (0.72)	2.6 (0.65)	See Kit Instruction
125, 150, 175, 200	3.5 (0.87)	2.9 (0.72)	2.7 (0.67)	See Kit Instruction	
250, 300, 350, 400	3.7 (0.92)	3.1 (0.77)	2.8 (0.70)	2.6 (0.65)	See Kit Instruction
250, 300, 350, 400	3.7* (0.92)	3.1* (0.77)	2.8* (0.70)	2.6* (0.65)	See Kit Instruction
1.6** (0.40)					

* High Fire **Low Fire

TABLE 8

US - PROPANE GAS MANIFOLD PRESSURES [inch w.g. (kPa)]									
MODEL	Altitude in Feet (Meters)								
	0-2000 (0-610)	2001-3000 (610-915)	3001-4000 (915-1220)	4001-5000 (1220-1524)	5001-6000 (1525-1829)	6001-7000 (1830-2134)	7001-8000 (2134-2439)	8001-9000 (2439-2744)	9001-10000 (2744-3049)
030, 045, 060, 075, 090, 105	10.0 (2.49)	8.7 (2.16)	8.0 (1.99)	7.4 (1.84)	See Kit Instruction				
125, 150, 175, 200	10.0 (2.49)	8.8 (2.19)	8.0 (1.99)	7.3 (1.82)	See Kit Instruction				
250, 300, 350, 400	10.5 (2.61)	8.2 (2.04)	See Kit Instruction						

NOTE - A natural to LP/propane gas changeover kit is required to convert the unit in the field. Refer to the in-installation instructions supplied with the changeover kit for conversion procedure.

Limit Control Switch

The limit control switch(es) is factory-set and is not field-adjustable.

Louver Vane Adjustment

Rotate louver vanes to direct airflow upward, downward, straight, or any combination of these directions. When 30/105 units are installed in an inverted position, louvers must be removed and rotated 180 degrees as shown in the installation section.

Combustion Air Pressure Switch

This pressure switch checks for proper combustion air inducer operation before allowing an ignition trial. The switch is factory-set. No field adjustment is necessary. For high altitude applications, see the Engineering Handbook.

Flame Rollout Switch

This normally closed switch opens on a temperature rise. See the parts arrangement for location. These switches are not adjustable.

Service

CAUTION

Turn off gas and electrical power to unit before performing any maintenance or service operations on this unit. Remember to follow lighting instructions when putting unit back into operation after service or maintenance.

The unit heater and vent system shall be inspected once a year by a licensed professional service technician, or equivalent.

BURNERS

- 1 - Periodically examine burner flames for proper appearance during the heating season.
- 2 - Before each heating season examine the burners for any deposits or blockage that may have occurred.
- 3 - Clean burners as follows:
 - a. Turn off both electrical and gas supplies to unit.
 - b. Disconnect gas supply piping, high tension and sensor leads. Remove gas manifold. Remove burner box top. Remove burner cluster assembly.
 - c. Clean burners as necessary. Make sure that burner heads line up properly to ensure flame crossover. Check spark gap on electrode and adjust if required. The gap should be between 0.110" and 0.140" (3mm to 4mm). The gap may be checked with appropriately sized twist drills or feeler gauges.
 - d. Reinstall burner cluster assembly, burner box top, gas manifold, high tension and sensor leads. Reconnect gas supply piping.
 - e. Restore electrical power and gas supply. Follow lighting instructions to light unit. Check burner flame.

FLUE PASSAGEWAY AND FLUE BOX

The flue passages and flue box should be inspected and cleaned prior to each heating season. The sequence of operation should be as follows:

- 1 - Turn off both electrical and gas supply to unit.
- 2 - Disconnect combustion air inducer wiring.
- 3 - Remove combustion air inducer assembly. Remove flue box. If necessary, remove inducer assembly from flue box. Clean flue box with wire brush.
- 4 - Remove burners as described in "Burners" section.
- 5 - Clean tubes with a wire brush.
- 6 - Reassemble unit. The combustion air and flue box gaskets should also be replaced during reassembly.
- 7 - Restore electrical power and gas supply. Follow lighting instructions to light unit. Check operation of unit.

COMBUSTION AIR INDUCER

Under normal operating conditions, the combustion air inducer should be checked and cleaned prior to the heating season with the power supply disconnected. Use a small brush to clean inducer wheel.

ELECTRICAL

- 1 - Check all wiring for loose connections.
- 2 - Check for correct voltage at unit (unit operating).
- 3 - Check amperage draw.

FLUE AND CHIMNEY

Check all vent and vent connector joints for tightness. Ensure that connections are sealed and that there are no blockages.

FAILURE TO OPERATE

If unit fails to operate check the following:

- 1 - Is thermostat calling for heat?
- 2 - Is main disconnect closed?
- 3 - Is there a breaker tripped or a fuse blown?
- 4 - Is gas turned on at meter?
- 5 - Is manual shutoff valve open?
- 6 - Is unit ignition system in lock out? If unit locks out again, call service technician to inspect unit.
- 7 - Is pressure switch closed? Obstructed flue will cause unit to shut off at pressure switch. Check flue passage and outlet.

SAFETY SHUT-OFF VALVE TEST

The safety shut-off valve test procedure is as follows:

- 1 - Turn off the manual gas valve.
- 2 - Set the thermostat to call for heat.
- 3 - System begins normal sequence of operation.
- 4 - After approximately 30 seconds (pre purge period) the LED will fast flash indicating the gas valve is powered.

5 - After 10 seconds, the gas valve closes and steps 4 and 5 will repeat two additional times before locking out the gas valve, which will be indicated by two flashes on the LED.

6 - To restart the system, de-energize the thermostat call for heat and follow the operating instructions under "Unit Start-Up and Operation."

REPAIR PARTS

When ordering repair parts, include the complete unit model number listed on the unit rating plate. For example:UHRS-45A-1. Contact the installing dealer, or visit www.adpnow.com for a list of dealers in the area. Include manufacturer's or distributor's name and address. It is a requirement in the Z83.8 standard.

REPAIR PARTS

When ordering repair parts, include the complete unit model number listed on the unit rating plate. For example:UHRS-45A-1. Contact the installing dealer, or visit www.adpnow.com for a list of dealers in the area. Include manufacturer's or distributor's name and address. It is a requirement in the Z83.8 standard.

START-UP AND PERFORMANCE CHECKLIST

Job Name: _____ Job No.: _____ Date: _____
Job Location: _____ City: _____ State/Province: _____
Installer: _____ City: _____ State/Province: _____
Unit Model No.: _____ Serial No.: _____ Service Technician: _____

Electrical Connections Tight _____ Air Shutters Properly Adjusted (If Installed) _____
Supply Voltage _____ Flue Connections Tight _____
Blower Motor Lubrication O. . _____ Fan Timer Operation Checked _____
Gas Piping Connections Tight & Leak-Tested _____

THERMOSTAT

Blower Motor Amps _____
Furnace Btu Input _____
Line Pressure _____
Manifold Pressure _____ w.c.

Calibrated _____
Heat Anticipator Properly Set _____
Level _____



ADP Unit Heater Limited Warranty

Term of Warranty: Advanced Distributor Products (ADP) warrants that products sold shall be of merchantable quality, free of defects in material and workmanship, under normal use and service, for a period of two (2) years from the date of installation, **not** to exceed three (3) years from the date of manufacture subject to the terms of ADP's limited warranty.

Unit Heater Extended Components: This warranty provides extended coverage on Aluminized Heat Exchangers for ten (10) years and Stainless Steel Heat Exchangers for fifteen (15) years. The extended warranty coverage begins with the installation date and represents the total warranty period for the specific component. ADP, at its option, will furnish a replacement heat exchanger or allow a credit (in the amount of the heat exchanger original selling price) toward the purchase of a new ADP unit heater.

For information on this products warranty, including **complete** warranty terms, registering for an extended warranty*, or instructions on how to file a warranty claim, please go to www.ADPwarranty.com.

** In such states or provinces where registration requirements are prohibited, failure to complete registration by the consumer does not diminish his or her warranty rights.*

EQUIPMENT INFORMATION

Please complete information below and retain this warranty for records and future reference.

Unit Model Number: _____

Serial Number: _____

Installing Contractor: _____

Installation Date: _____ Phone: _____

