



© 2021 Lennox Industries Inc.
Dallas, Texas USA



INSTALLATION INSTRUCTIONS ML180UHV

MERIT® SERIES GAS FURNACE
HORIZONTAL AIR DISCHARGE

507945-01
01/2021
Supersedes 08/2019



**THIS MANUAL MUST BE LEFT WITH THE
HOMEOWNER FOR FUTURE REFERENCE**

! This is a safety alert symbol and should never be ignored. When you see this symbol on labels or in manuals, be alert to the potential for personal injury or death.

! IMPORTANT

DO NOT use the bracket securing the heat exchanger to lift, drag or pull the furnace to its installation location. Doing so will loosen the bracket causing noise and or unsafe operation.

! WARNING

Improper installation, adjustment, alteration, service or maintenance can cause property damage, personal injury or loss of life. Installation and service must be performed by a licensed professional HVAC installer (or equivalent), service agency or the gas supplier.



Contents

Unit Dimensions - inches (mm).....	2
ML180UHV Gas Furnace	3
Shipping and Packing List	3
Safety	3
Use of Furnace as a Construction Heaterl	4
General.....	4
Combustion, Dilution, Ventilation Air.....	5
Setting Equipment	8
Filters	11
Duct System	12
Venting	13

Gas Piping	20
Electrical	22
Integrated Control.....	25
Unit Start-Up.....	29
Gas Pressure Measurement.....	30
Proper Combustion.....	30
High Altitude	30
Other Unit Adjustments.....	32
Service.....	32
Blower Data	35



Unit Dimensions - inches (mm)

- ¹ NOTE - 60C size units that require air volumes over 1800 cfm must have one of the following:
1. Single side return air and Optional Return Air Base with transition that must accommodate required 20 x 25 x 1 inch (508 x 635 x 25 mm) air filter to maintain proper velocity.
 2. Bottom return air.
 3. Return air from both sides.
 4. Bottom and one side return air.
- See Blower Performance Tables for additional information.

² Flue outlet may be horizontal but furnace must be vented vertically

³ Optional External Side Return Air Filter Kit is not for use with the optional Return Air Base.

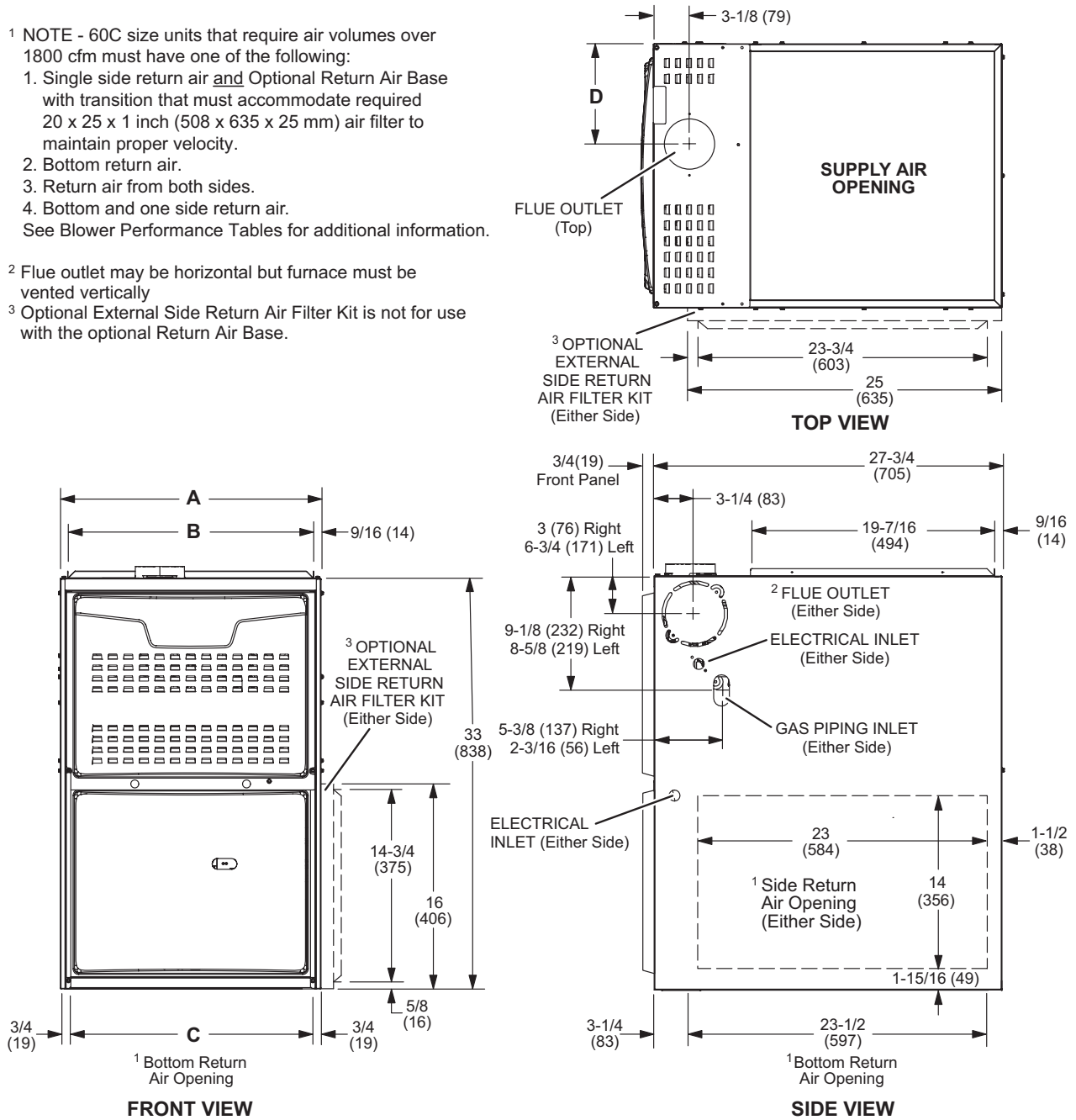

ML180UHV Model	A		B		C		D	
	in	mm	in	mm	in	mm	in	mm
030V36A 045V36A 070V36A	14-1/2	368	13-3/8	340	13	330	4-3/4	121
070V36B 070V48B 090V48B	17-1/2	446	16-3/8	416	16	406	6-1/4	159
110V60C	21	533	19-7/8	504	19-1/2	495	8	203

ML180UHV Gas Furnace

The ML180UHV unit is shipped ready for installation in the upflow or horizontal right position (for horizontal left position the combustion air pressure switch must be moved) fueled by natural gas. A conversion kit (ordered separately) is required for use in LP/Propane gas applications. The furnace is shipped with the bottom panel in place. The bottom panel must be removed if the unit is to be installed in a horizontal application. The panel may also be removed in upflow applications.

Shipping and Packing List

Package 1 of 1 contains

- 1 - Assembled ML180UHV unit
- 1 - Bag assembly containing the following:
 - 2 - Screws
 - 1 - Snap bushing
 - 1 - Snap plug
 - 1 - Wire tie
 - 1 - Vent warning label
 - 1 - Owner's manual and warranty card

The following items may be ordered separately:

- 1 - Thermostat
- 1 - Suspension kit (for horizontal installations)
- 1 - LP/Propane changeover kit
- 1 - Return air base
- 1 - High altitude kit
- 1 - Side filter kit

Check equipment for shipping damage. If you find any damage, immediately contact the last carrier.

Safety Information

DANGER

Danger of explosion.

There are circumstances in which odorant used with LP/propane gas can lose its scent. In case of a leak, LP/propane gas will settle close to the floor and may be difficult to smell. An LP/propane leak detector should be installed in all LP applications.

CAUTION

As with any mechanical equipment, contact with sharp sheet metal edges can result in personal injury. Take care while handling this equipment and wear gloves and protective clothing.

Certifications

ML180UHV units are CSA International certified to ANSI Z21.47.

In the USA, installation of gas furnaces must conform with local building codes. In the absence of local codes, units must be installed according to the current National Fuel Gas Code (ANSI-Z223.1). The National Fuel Gas Code is available from the following address:

American National Standards Institute, Inc.
11 West 42nd Street
New York, NY 10036

Clearances

Adequate clearance must be made around the air openings into the vestibule area. In order to ensure proper operation, combustion and ventilation air supply must be provided according to the current National Fuel Gas Code.

Vent installations must be consistent with the National Fuel Gas Code venting tables (in this instruction) and applicable provisions of local building codes.

This furnace is CSA International certified for installation clearances to combustible material as listed on the unit nameplate and in the tables in figures 7 and 11. Accessibility and service clearances must take precedence over fire protection clearances.

NOTE - For installation on combustible floors, the furnace shall not be installed directly on carpeting, tile, or other combustible material other than wood flooring.

Installed Locations

For installation in a residential garage, the furnace must be installed so that the burner(s) and the ignition source are located no less than 18 inches (457 mm) above the floor. The furnace must be located or protected to avoid physical damage by vehicles. When a furnace is installed in a public garage, hangar, or other building that has a hazardous atmosphere, the furnace must be installed according to recommended good practice requirements and current National Fuel Gas Code.

Temperature Rise

NOTE - Furnace must be adjusted to obtain a temperature rise within the range specified on the unit nameplate. Failure to do so may cause erratic limit operation and may result in premature heat exchanger failure.

This ML180UHV furnace must be installed so that its electrical components are protected from water.

Installed in Combination with a Cooling Coil

When this furnace is used with cooling units, it shall be installed in parallel with, or on the upstream side of, cooling units to avoid condensation in the heating compartment. See figure 1.

With a parallel flow arrangement, a damper (or other means to control the flow of air) must adequately prePage 4 vent chilled air from entering the furnace. If the damper is manually operated, it must be equipped to prevent operation of either the heating or the cooling unit, unless it is in the full HEAT or COOL setting. See figure 1.

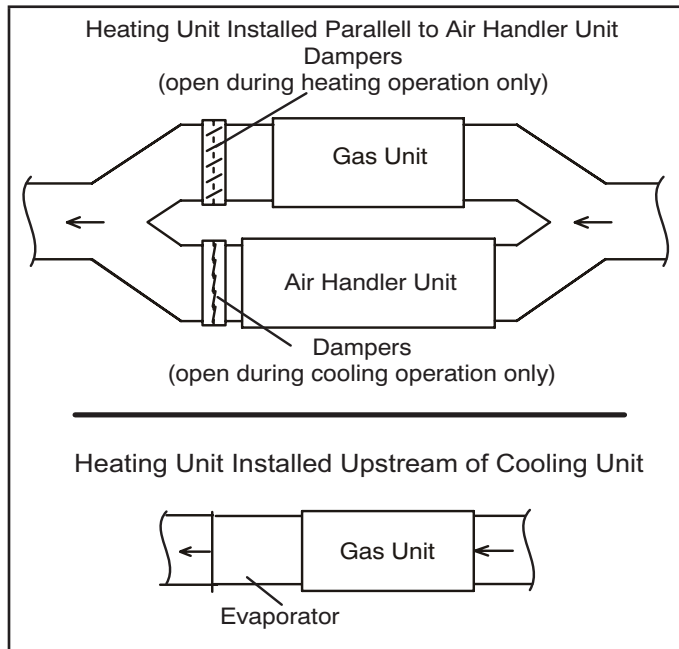

FIGURE 1

When installed, this furnace must be electrically grounded according to local codes. In addition, in the United States, installation must conform with the current National Electric Code, ANSI/NFPA No. 70. The National Electric Code (ANSI/NFPA No. 70) is available from the following address:

National Fire Protection Association
1 Battery March Park
Quincy, MA 02269

NOTE - This furnace is designed for a minimum continuous return air temperature of 60°F (16°C) or an intermittent operation down to 55°F (13°C) dry bulb for cases where a night setback thermostat is used. Return air temperature must not exceed 85°F (29°C) dry bulb.

The ML180UHV furnace may be installed in alcoves, closets, attics, basements, garages, crawl spaces and utility rooms in the upflow or horizontal position.

This furnace design has not been CSA International certified for installation in mobile homes, recreational vehicles, or outdoors.

Use of Furnace as Construction Heater

Lennox does not recommend the use of ML180UHV units as a construction heater during any phase of construction. Very low return air temperatures, harmful vapors and operation of the unit with clogged or misplaced filters will damage the unit.

ML180UHV units may be used for heating of buildings or structures under construction, if the following conditions are met:

- The vent system must be permanently installed per these installation instructions.
- A room thermostat must control the furnace. The use of fixed jumpers that will provide continuous heating is not allowed.
- The return air duct must be provided and sealed to the furnace.
- Return air temperature range between 60°F (16°C) and 80°F (27°C) must be maintained.
- Air filters must be installed in the system and must be maintained during construction.
- Air filters must be replaced upon construction completion.
- The input rate and temperature rise must be set per the furnace rating plate.
- One hundred percent (100%) outdoor air must be provided for combustion air requirements during construction. Temporary ducting may supply outdoor air to the furnace. Do not connect duct directly to the furnace. Size the temporary duct following these instructions in section for Combustion, Dilution and Ventilation Air in a confined space with air from outside.
- The furnace heat exchanger, components, duct system, air filters and evaporator coils must be thoroughly cleaned following final construction clean-up.
- All furnace operating conditions (including ignition, input rate, temperature rise and venting) must be verified according to these installation instructions.

General

These instructions are intended as a general guide and do not supersede local codes in any way. Consult authorities having jurisdiction before installation. In addition to the requirements outlined previously, the following general recommendations must be considered when installing a ML180UHV furnace:

- Place the furnace as close to the center of the air distribution system as possible. The furnace should also be located close to the chimney or vent termination point.

- Do not install the furnace where drafts might blow directly into it. This could cause improper combustion and unsafe operation.
- Do not block the furnace combustion air openings with clothing, boxes, doors, etc. Air is needed for proper combustion and safe unit operation.
- When the furnace is installed in an attic or other insulated space, keep insulation away from the furnace.

NOTE - The Commonwealth of Massachusetts stipulates these additional requirements:

- **Gas furnaces shall be installed by a licensed plumber or fitter only.**
- **The gas cock must be "T handle" type.**
- **When a furnace is installed in an attic, the passageway to and service area surrounding the equipment shall be floored.**

Combustion, Dilution & Ventilation Air

In the past, there was no problem in bringing in sufficient outdoor air for combustion. Infiltration provided all the air that was needed. In today's homes, tight construction practices make it necessary to bring in air from outside for combustion. Take into account that exhaust fans, appliance vents, chimneys, and fireplaces force additional air that could be used for combustion out of the house. Unless outside air is brought into the house for combustion, negative pressure (outside pressure is greater than inside pressure) will build to the point that a downdraft can occur in the furnace vent pipe or chimney. As a result, combustion gases enter the living space creating a potentially dangerous situation.

In the absence of local codes concerning air for combustion and ventilation, use the guidelines and procedures in this section to install ML180UHE furnaces to ensure efficient and safe operation. You must consider combustion air needs and requirements for exhaust vents. A portion of this information has been reprinted with permission from the National Fuel Gas Code (ANSI-Z223.1). This reprinted material is not the complete and official position of the ANSI on the referenced subject, which is represented only by the standard in its entirety.

CAUTION

Do not install the furnace in a corrosive or contaminated atmosphere. Meet all combustion and ventilation air requirements, as well as all local codes.

CAUTION

Insufficient combustion air can cause headaches, nausea, dizziness or asphyxiation. It will also cause excess water in the heat exchanger resulting in rusting and premature heat exchanger failure. Excessive exposure to contaminated combustion air will result in safety and performance related problems. Avoid exposure to the following substances in the combustion air supply:

- Permanent wave solutions
- Chlorinated waxes and cleaners
- Chlorine base swimming pool chemicals
- Water softening chemicals
- De-icing salts or chemicals
- Carbon tetrachloride
- Halogen type refrigerants
- Cleaning solvents (such as perchloroethylene)
- Printing inks, paint removers, varnishes, etc.
- Hydrochloric acid
- Cements and glues
- Antistatic fabric softeners for clothes dryers
- Masonry acid washing materials

In addition to providing combustion air, fresh outdoor air dilutes contaminants in the indoor air. These contaminants may include bleaches, adhesives, detergents, solvents and other contaminants which can corrode furnace components.

The requirements for providing air for combustion and ventilation depend largely on whether the furnace is installed in an unconfined or a confined space

Unconfined Space

An unconfined space is an area such as a basement or large equipment room with a volume greater than 50 cubic feet (1.42 m³) per 1,000 Btu (.29 kW) per hour of the combined input rating of all appliances installed in that space.

This space also includes adjacent rooms which are not separated by a door. Though an area may appear to be unconfined, it might be necessary to bring in outdoor air for combustion if the structure does not provide enough air by infiltration. If the furnace is located in a building of tight construction with weather stripping and caulking around the windows and doors, follow the procedures in the air from outside section.

Confined Space

A confined space is an area with a volume less than 50 cubic feet (1.42 m³) per 1,000 Btu (.29 kW) per hour of the combined input rating of all appliances installed in that space. This definition includes furnace closets or small equipment rooms.

When the furnace is installed so that supply ducts carry air circulated by the furnace to areas outside the space containing the furnace, the return air must be handled by ducts which are sealed to the furnace casing and which terminate outside the space containing the furnace.

This is especially important when the furnace is mounted on a platform in a confined space such as a closet or small equipment room. Even a small leak around the base of the unit at the platform or at the return air duct connection can cause a potentially dangerous negative pressure condition. Air for combustion and ventilation can be brought into the confined space either from inside the building or from outside.

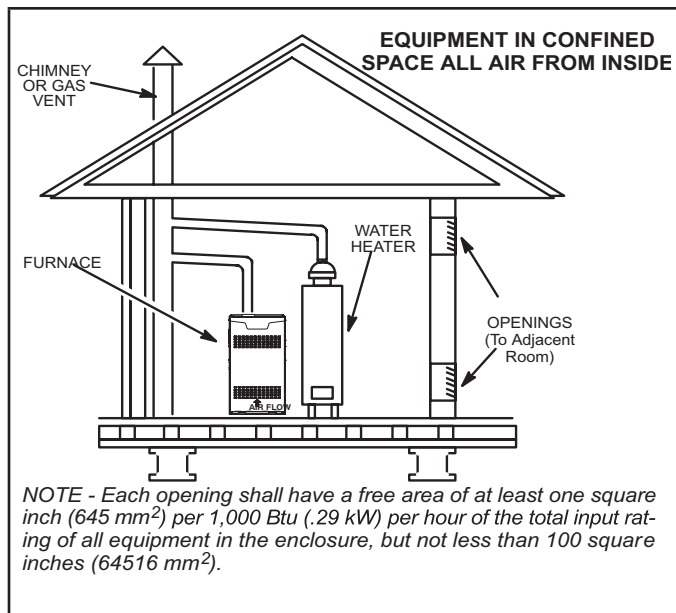

FIGURE 2

Air from Inside

If the confined space that houses the furnace adjoins a space categorized as unconfined, air can be brought in by providing two permanent openings between the two spaces.

Each opening must have a minimum free area of 1 square inch (645 mm²) per 1,000 Btu (.29 kW) per hour of total input rating of all gas-fired equipment in the confined space. Each opening must be at least 100 square inches (64516 mm²). One opening shall be within 12 inches (305 mm) of the top of the enclosure and one opening within 12 inches (305 mm) of the bottom. See figure 2.

Air from Outside

If air from outside is brought in for combustion and ventilation, the confined space must have two permanent openings. One opening shall be within 12 inches (305 mm) of the top of the enclosure and one opening within 12 inches (305 mm) of the bottom. These openings must communicate directly or by ducts with the outdoors or spaces (crawl or attic) that freely communicate with the outdoors or indirectly through vertical ducts. Each opening shall have a minimum free area of 1 square inch (645 mm²) per 4,000 Btu (1.17 kW) per hour of total input rating of all equipment in the enclosure. See figures 3 and 4. When communicating with the outdoors through horizontal ducts, each opening shall have a minimum free area of 1 square inch (645 mm²) per 2,000 Btu (.56 kW) per total input rating of all equipment in the enclosure. See figure 5.

When ducts are used, they shall be of the same cross-sectional area as the free area of the openings to which they connect. The minimum dimension of rectangular air ducts shall be no less than 3 inches (75 mm). In calculating free area, the blocking effect of louvers, grilles, or screens must be considered. If the design and free area of protective covering is not known for calculating the size opening required, it may be assumed that wood louvers will have 20 to 25 percent free area and metal louvers and grilles will have 60 to 75 percent free area. Louvers and grilles must be fixed in the open position or interlocked with the equipment so that they are opened automatically during equipment operation

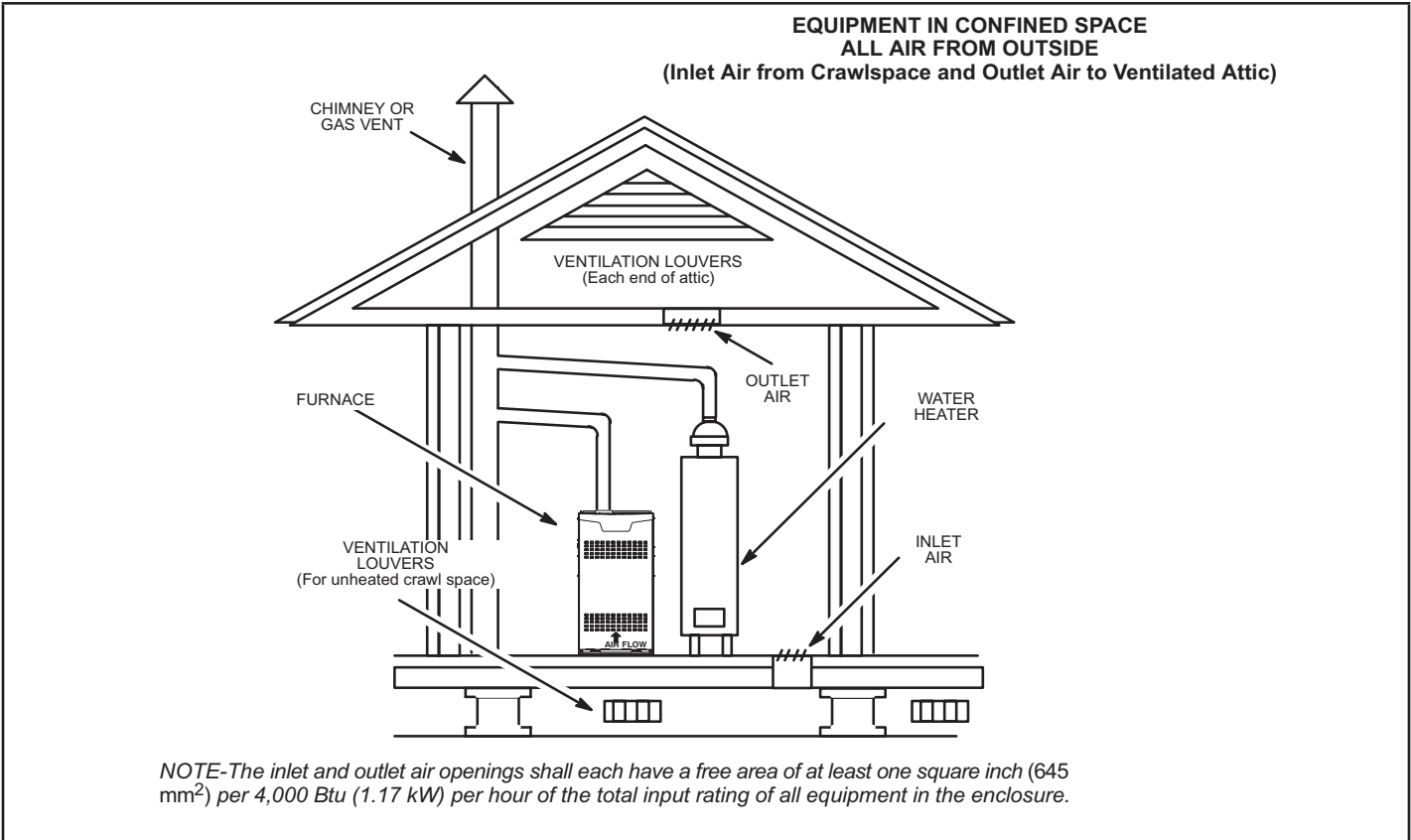

FIGURE 3

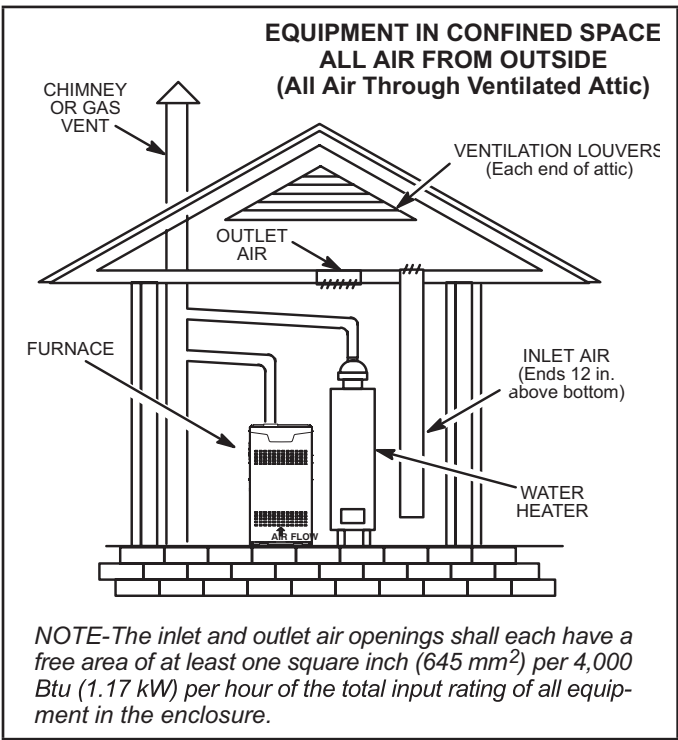

FIGURE 4

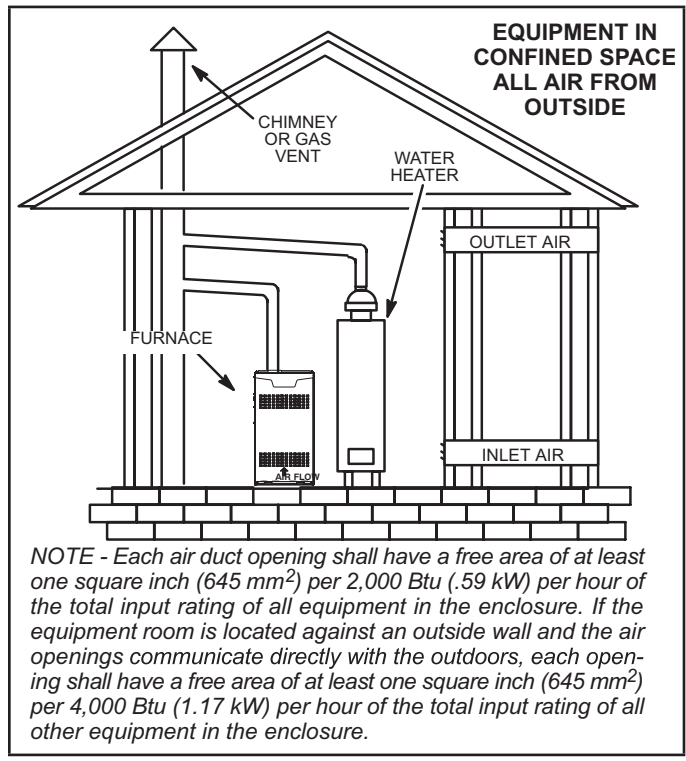

FIGURE 5

Setting Equipment

⚠ WARNING

Do not install the furnace on its front or its back. Do not connect the return air ducts to the back of the furnace. Doing so will adversely affect the operation of the safety control devices, which could result in personal injury or death.

The ML180UHV gas furnace can be installed as shipped in either the upflow position or the horizontal position.

Select a location that allows for the required clearances that are listed on the unit nameplate. Also consider gas supply connections, electrical supply, vent connection, and installation and service clearances [24 inches (610 mm) at unit front]. The unit must be level.

NOTE - Units with 1/2 hp blower motors are equipped with three flexible legs and one rigid leg. See figure 6. The rigid leg is equipped with a shipping bolt and a flat white plastic washer (rather than the rubber mounting grommet used with a flexible mounting leg). **The bolt and washer must be removed before the furnace is placed into operation.** After the bolt and washer have been removed, the rigid leg will not touch the blower housing.

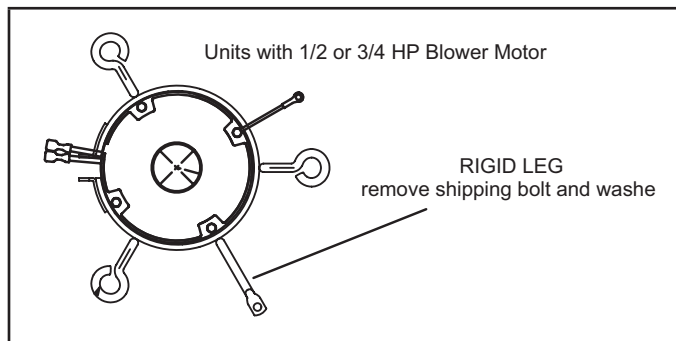

FIGURE 6

Upflow Applications

Allow for clearances to combustible materials as indicated on the unit nameplate. Minimum clearances for closet or alcove installations are shown in figure 7.

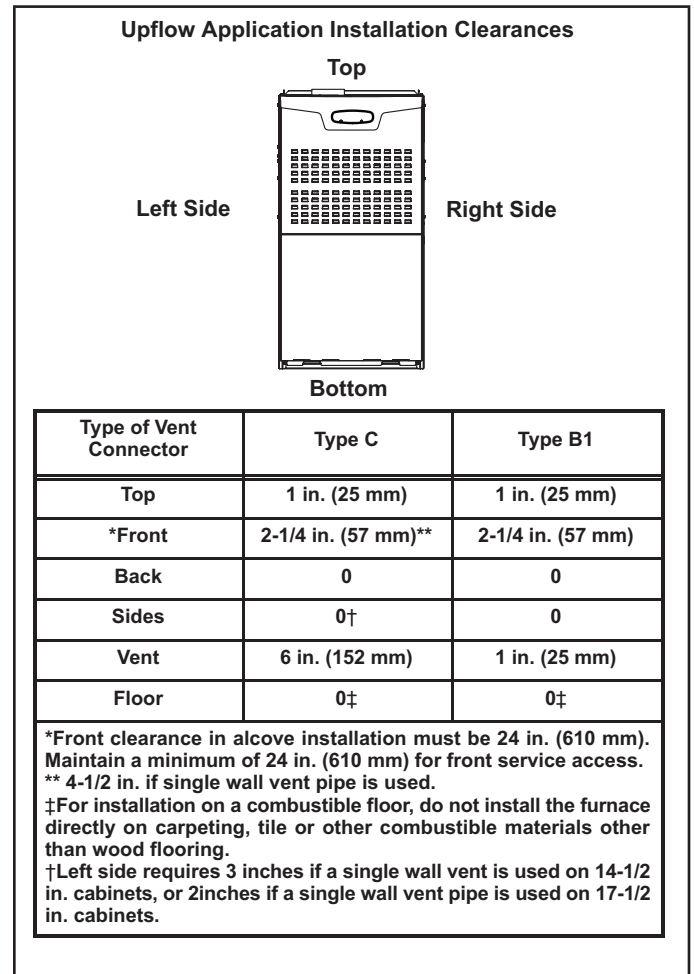

FIGURE 7

Return Air -- Upflow Applications

Return air can be brought in through the bottom or either side of the furnace installed in an upflow application. If the furnace is installed on a platform with bottom return, make an airtight seal between the bottom of the furnace and the platform to ensure that the furnace operates properly and safely. The furnace is equipped with a removable bottom panel to facilitate installation.

Markings are provided on both sides of the furnace cabinet for installations that require side return air. Cut the furnace cabinet at the maximum dimensions shown on page 2.

NOTE - 60C units that require air volumes over 1800 cfm (850 L/s) must have one of the following:

- 1 - Single side return air and Optional Return Air Base with transition that must accommodate required 20 x 25 x 1 inch (508 x 635 x 25 mm) air filter to maintain proper velocity.
- 2 - Bottom return air
- 3 - Return air from both sides.
- 4 - Bottom and one side return air.

Refer to Engineering Handbook for additional information.

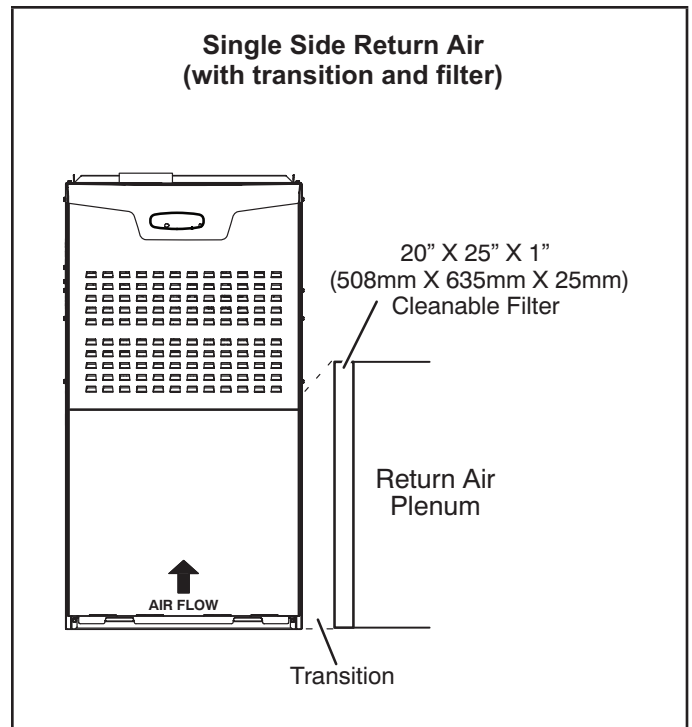

FIGURE 8

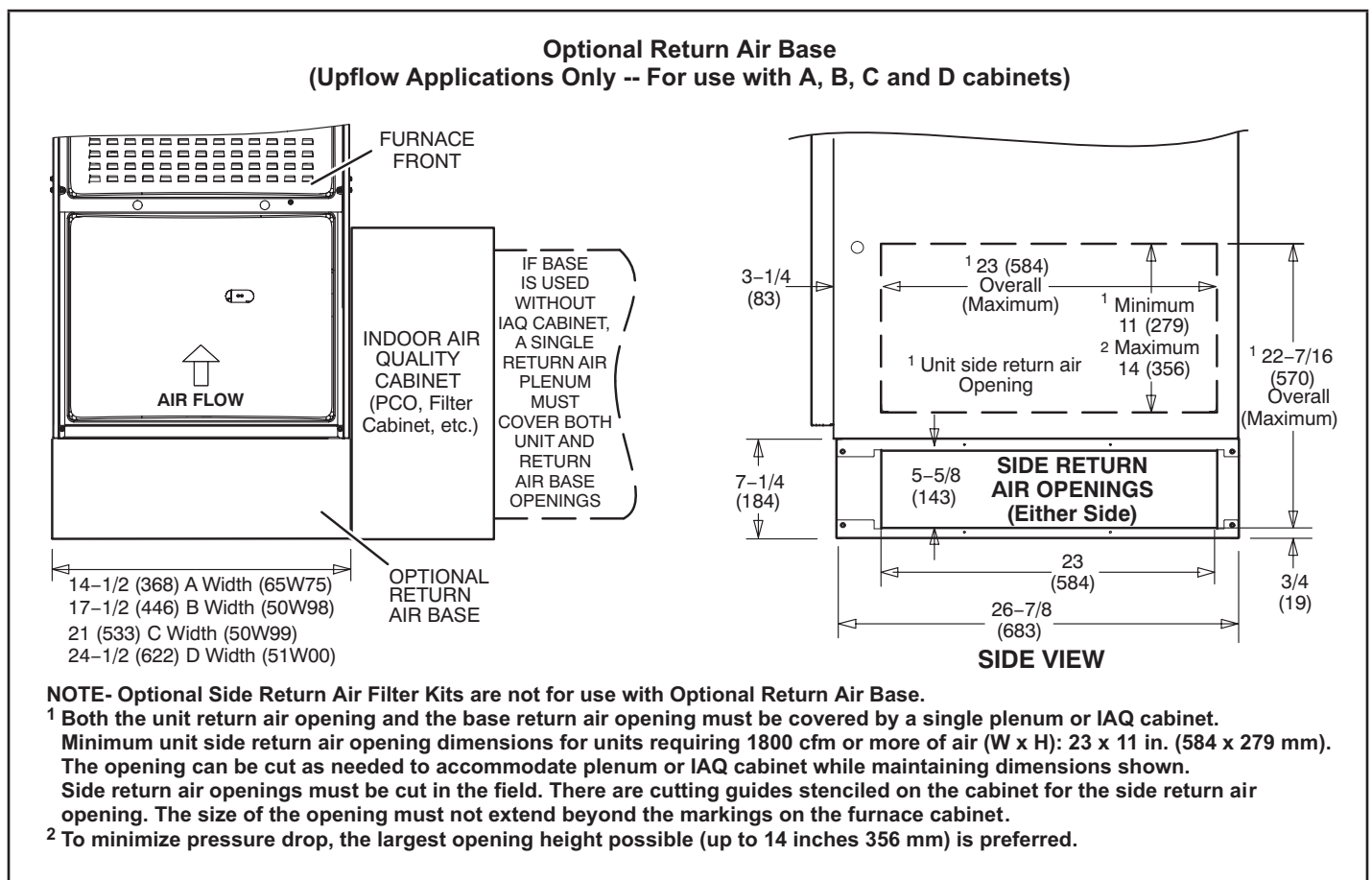

FIGURE 9

Removing the Bottom Panel

Remove the two screws that secure the bottom cap to the furnace. Pivot the bottom cap down to release the bottom panel. Once the bottom panel has been removed, reinstall the bottom cap. See figure 10.

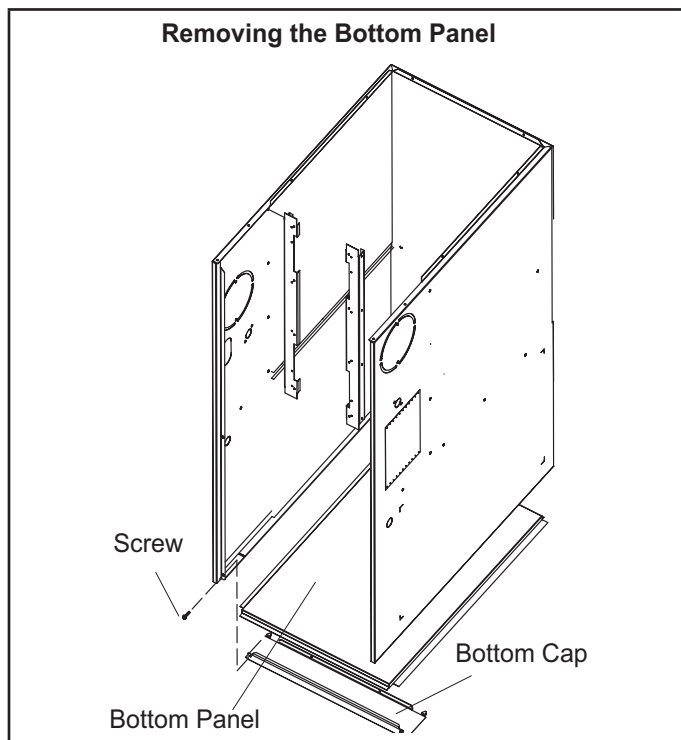

FIGURE 10

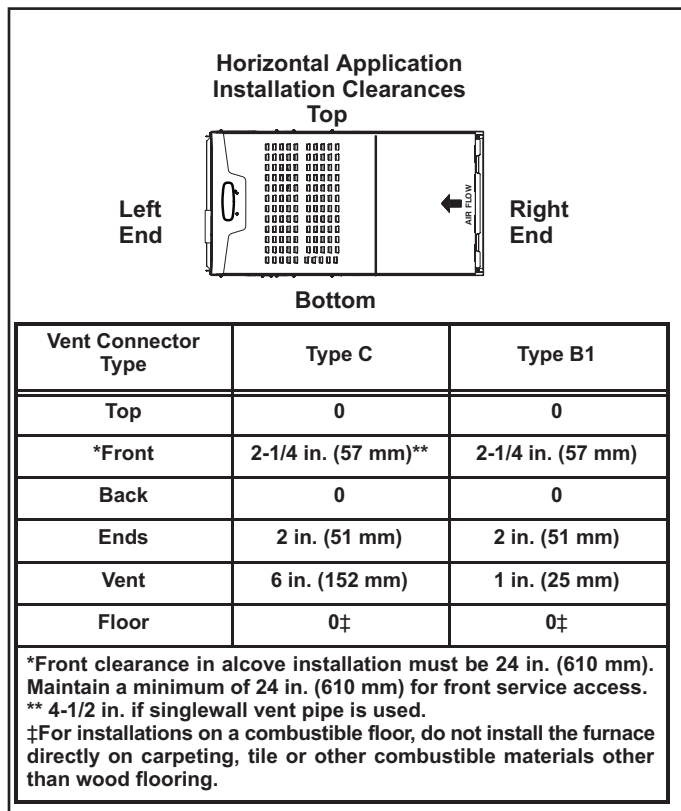

FIGURE 11

Horizontal Applications

The ML180UHV furnace can be installed in horizontal applications. Order horizontal suspension kit (51W10) from Lennox, or use equivalent suspension method.

Allow for clearances to combustible materials as indicated on the unit nameplate. Minimum clearances for closet or alcove installations are shown in figure 11.

This furnace may be installed in either an attic or a crawlspace. Either suspend the furnace from roof rafters or floor joists, as shown in figure 12, or install the furnace on a platform, as shown in figure 13.

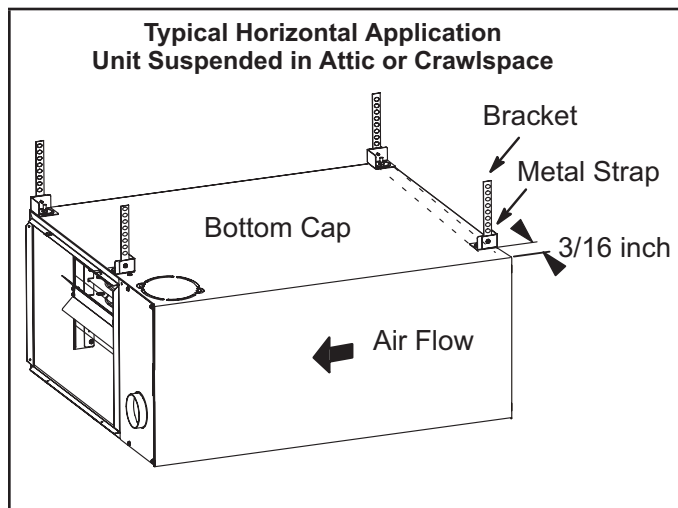

FIGURE 12

NOTE - Heavy-gauge perforated sheet metal straps may be used to suspend the unit from roof rafters or ceiling joists. When straps are used to suspend the unit in this way, support must be provided for both the ends. The straps must not interfere with the plenum or exhaust piping installation. **Cooling coils and supply and return air plenums must be supported separately.**

NOTE - When the furnace is installed on a platform in a crawlspace, it must be elevated enough to avoid water damage and to allow the evaporator coil to drain.

Return Air -- Horizontal Applications

Return air must be brought in through the end of a furnace installed in a horizontal application. The furnace is equipped with a removable bottom panel to facilitate installation. See figure 10.

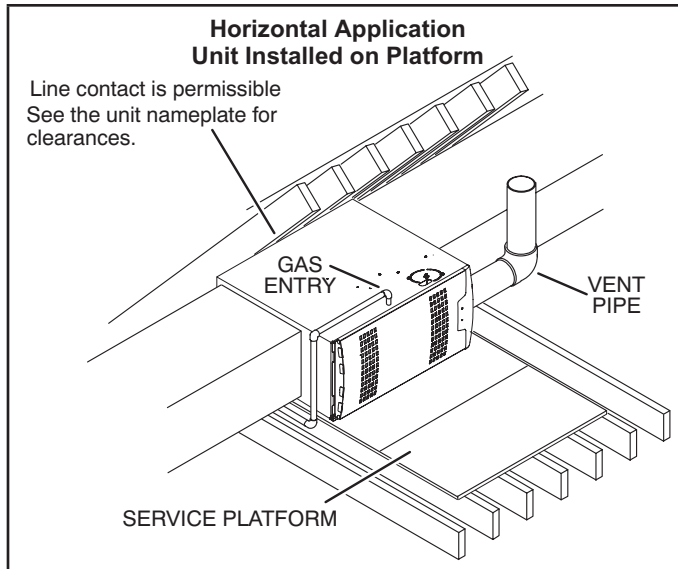

FIGURE 13

⚠ WARNING

Improper installation of the furnace can result in personal injury or death. Combustion and flue products must never be allowed to enter the return air system or the living space. Use screws and joint tape to seal the return air system to the furnace.

In platform installations with bottom return air, the furnace should be sealed airtight to the return air plenum. A door must never be used as a portion of the return air duct system. The base must provide a stable support and an airtight seal to the furnace. Allow absolutely no sagging, cracks, gaps, etc. The return and supply air duct systems must never be connected to or from other heating devices such as a fireplace or stove, etc. Fire, explosion, carbon monoxide poisoning, personal injury and/or property damage could result.

⚠ WARNING

The blower access panel must be securely in place when the blower and burners are operating. Gas fumes, which could contain carbon monoxide, can be drawn into living space resulting in personal injury or death.

Filters

This unit is not equipped with a filter or rack. A field-provided high-velocity filter is required for the unit to operate properly. Table 1 lists recommended filter sizes.

A filter must be in place any time the unit is operating.

⚠ IMPORTANT

If a highefficiency filter is being installed as part of this system to ensure better indoor air quality, the filter must be properly sized. Highefficiency filters have a higher static pressure drop than standardefficiency glass/foam filters. If the pressure drop is too great, system capacity and performance may be reduced.

The pressure drop may also cause the limit to trip more frequently during the winter and the indoor coil to freeze in the summer, resulting in an increase in the number of service calls.

Before using any filter with this system, check the specifications provided by the filter manufacturer against the data given in the appropriate Lennox Product Specifications bulletin. Additional information is provided in Service and Application Note ACC002 (August 2000).

TABLE 1

Furnace Cabinet Width	Filter Size	
	Side Return	Bottom Return
A - 14-1/2"	16 X 25 X 1 (1)	14 X 25 X 1 (1)
B - 17-1/2"	16 X 25 X 1 (1)	16 X 25 X 1 (1)
C - 21"	16 X 25 X 1 (1)	20 x 25 x 1 (1)

Duct System

Use industry-approved standards (such as those published by Air Conditioning Contractors of America or American Society of Heating, Refrigerating and Air Conditioning Engineers) to size and install the supply and return air duct system. This will result in a quiet and low-static pressure system that has uniform air distribution. See figure 14 for proper duct installation.

NOTE - Do not operate the furnace in the heating mode with an external static pressure that exceeds 0.5 inches w.c. Higher external static pressures may cause erratic limit operation.

Supply Air Plenum

If the furnace is installed without a cooling coil, a removable access panel must be installed in the supply air duct. The access panel should be large enough to permit inspection (either by smoke or reflected light) of the heat exchanger for leaks after the furnace is installed. The furnace access panel must always be in place when the furnace is operating and it must not allow leaks into the supply air duct system. Install self tapping screws in the three evaporator coil screw holes made for horizontal applications to seal the top cap to the vestibule panel.

Return Air Plenum

NOTE - Return air must not be drawn from a room where this furnace, or any other gas-fueled appliance (i.e., water heater), or carbon monoxide producing device (i.e., wood fireplace) is installed.

When return air is drawn from a room, a negative pressure is created in the room. If a gas appliance is operating in a room with negative pressure, the flue products can be pulled back down the vent pipe and into the room. This reverse flow of the flue gas may result in incomplete combustion and the formation of carbon monoxide gas. This toxic gas might then be distributed throughout the house by the furnace duct system.

In upflow applications, the return air can be brought in through the bottom or either side of the furnace. If a furnace with bottom return air is installed on a platform, make an airtight seal between the bottom of the furnace and the platform to ensure that the unit operates properly and safely. Use fiberglass sealing strips, caulking, or equivalent sealing method between the plenum and the furnace cabinet to ensure a tight seal. If a filter is installed, size the return air duct to fit the filter frame.

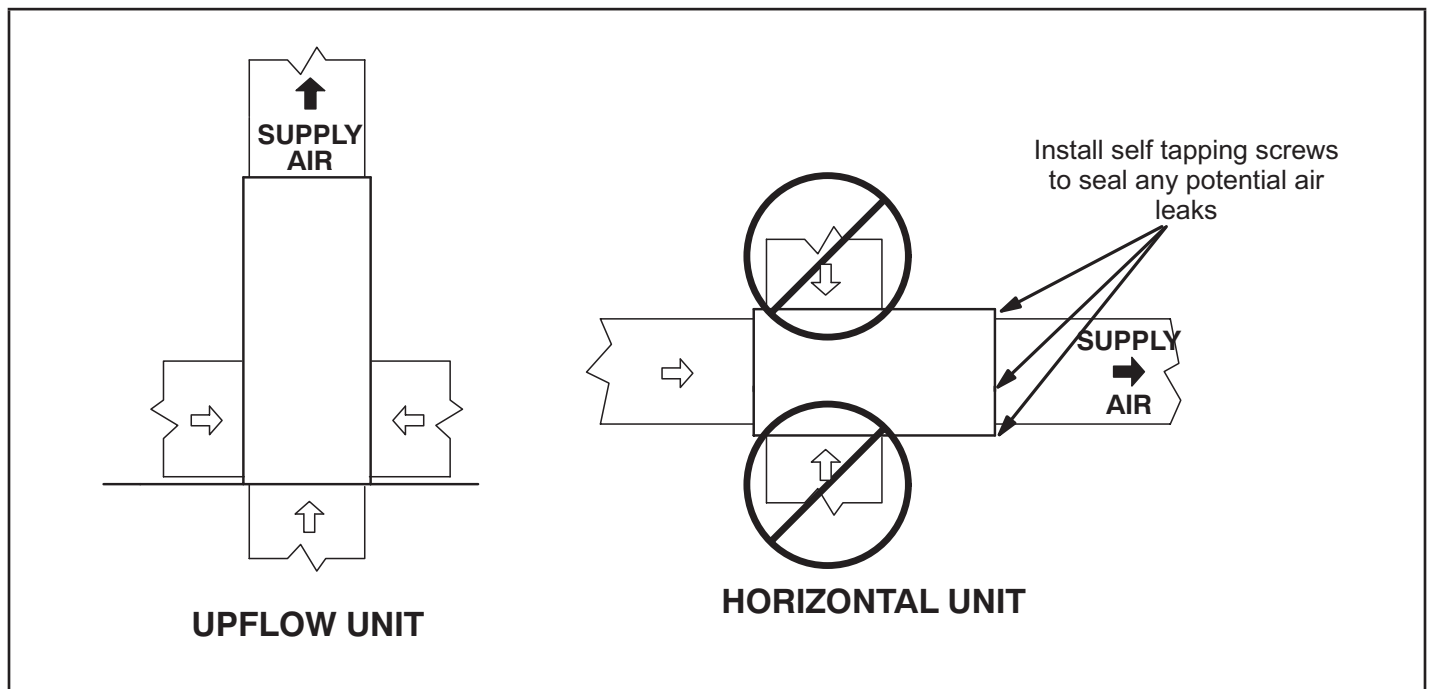

FIGURE 14

Venting

A 4-inch diameter flue transition is factory-installed on the combustion air inducer outlet of all models. Figure 16 shows the combustion air inducer as shipped from the factory.

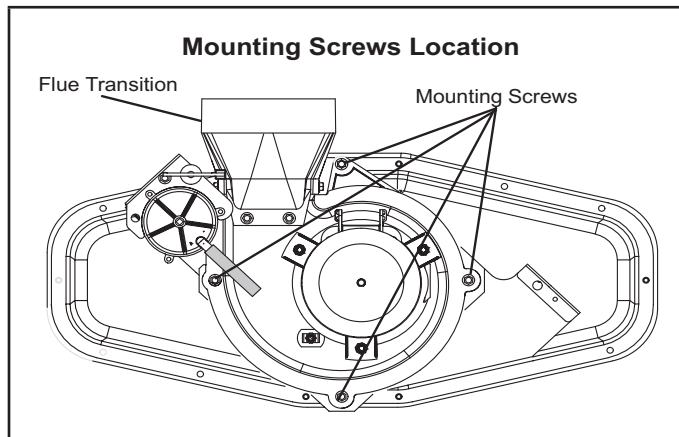

FIGURE 15

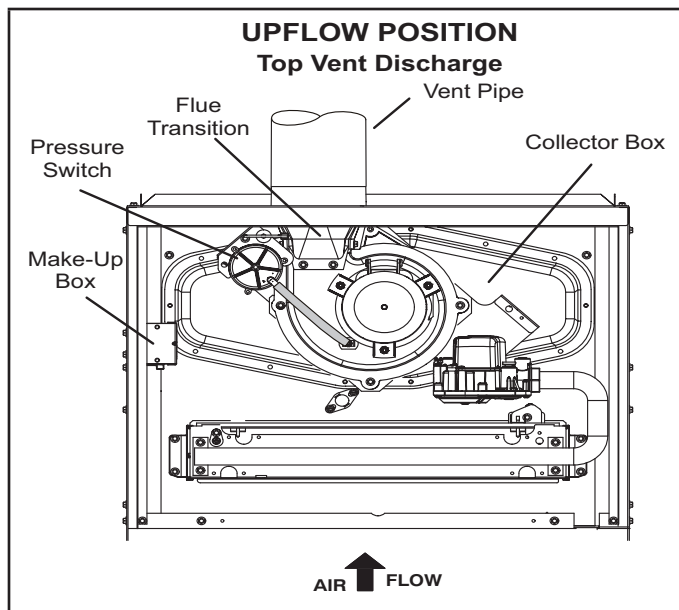

FIGURE 16

⚠ IMPORTANT

The unit will not vent properly with the flue transition pointed down in the 6 o'clock position. The combustion air inducer may be rotated clockwise or counterclockwise by 90° to allow for top or side vent discharge in all applications. When the unit is installed, the flue transition must be in the 9 o'clock, 12 o'clock or 3 o'clock position.

If necessary, reposition the combustion air inducer, pressure switch and/or make-up box as needed per the following steps. See figures 17 through 21.

1 - Remove the four mounting screws (figure 15) which secure the combustion air inducer / pressure switch assembly to the orifice plate. Lift the assembly and rotate it 90 degrees clockwise or counterclockwise to either the 3 o'clock position or to 9 o'clock position. Resecure with four screws. Gasket should be left in place.

2 - Use tin snips to cut preferred opening on the cabinet for repositioning the flue outlet. Use the cut-out piece as a cover plate to patch unused opening on cabinet.

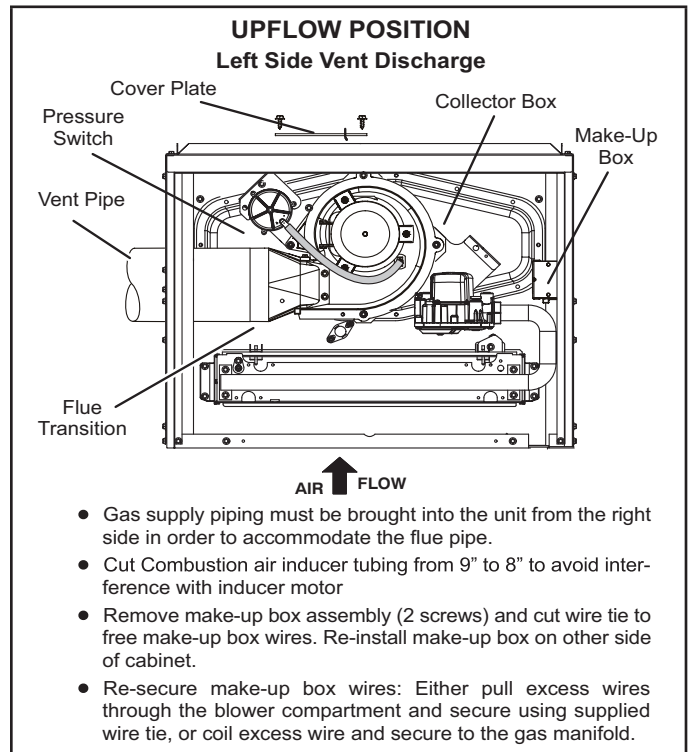

FIGURE 17

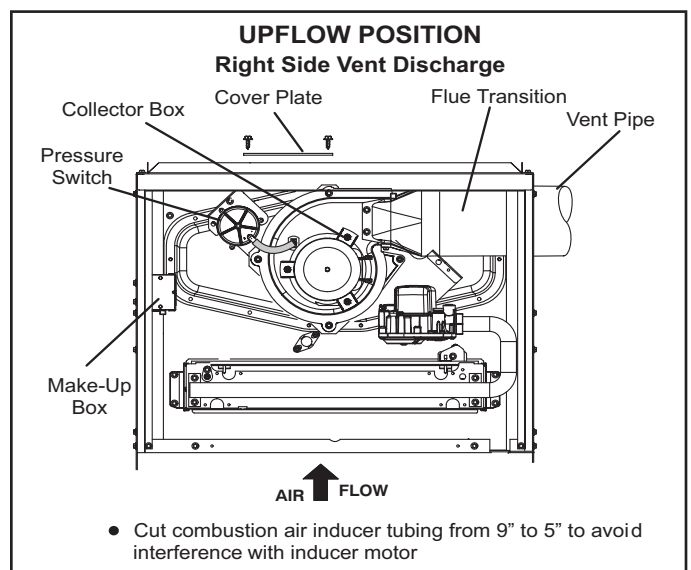

FIGURE 18

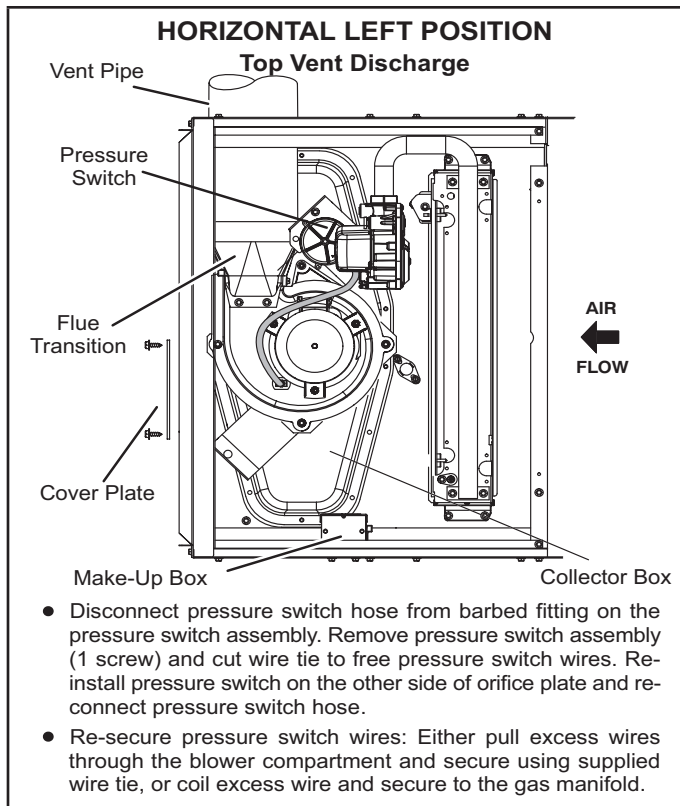

FIGURE 19

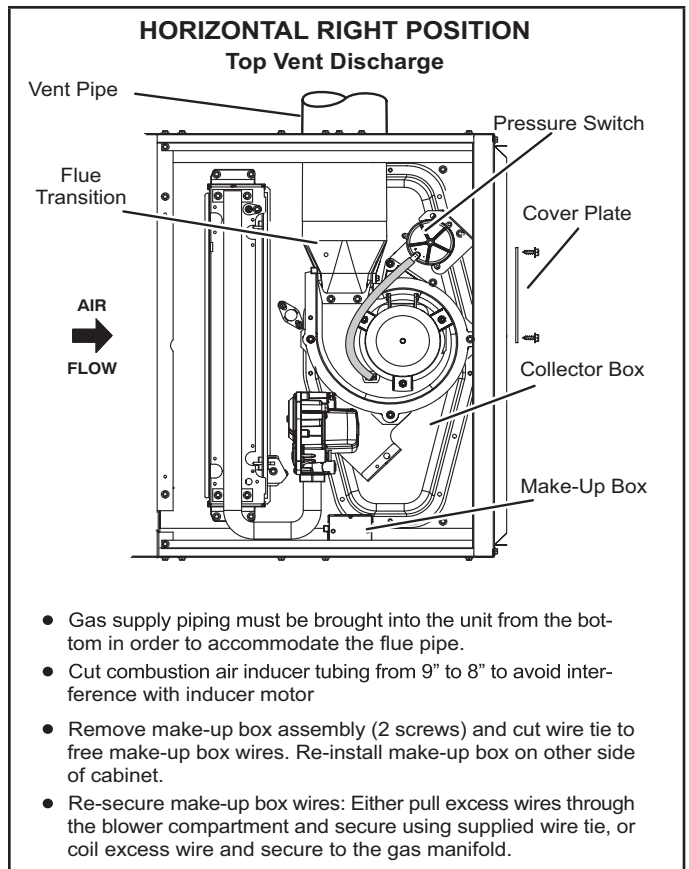

FIGURE 21

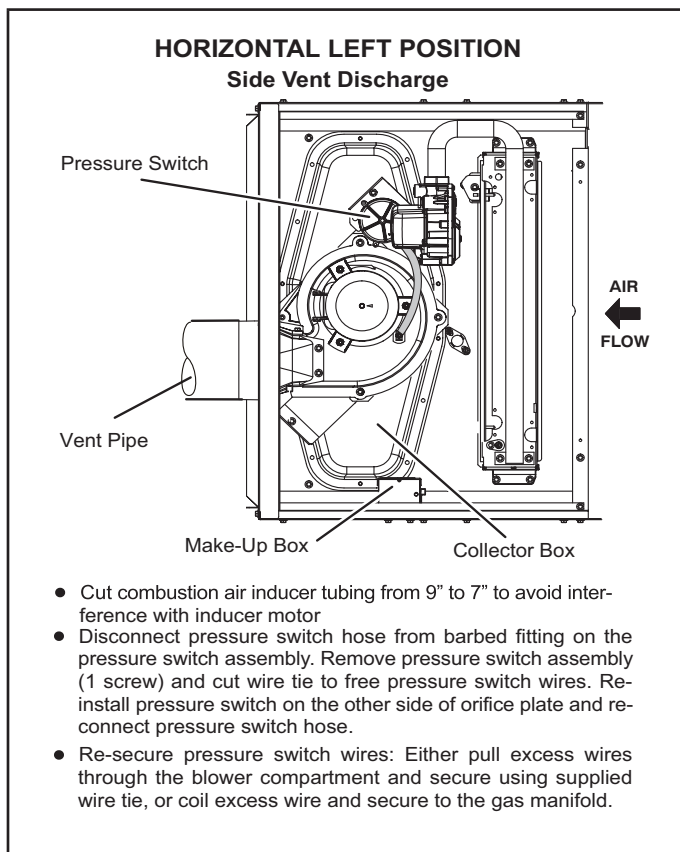

FIGURE 20

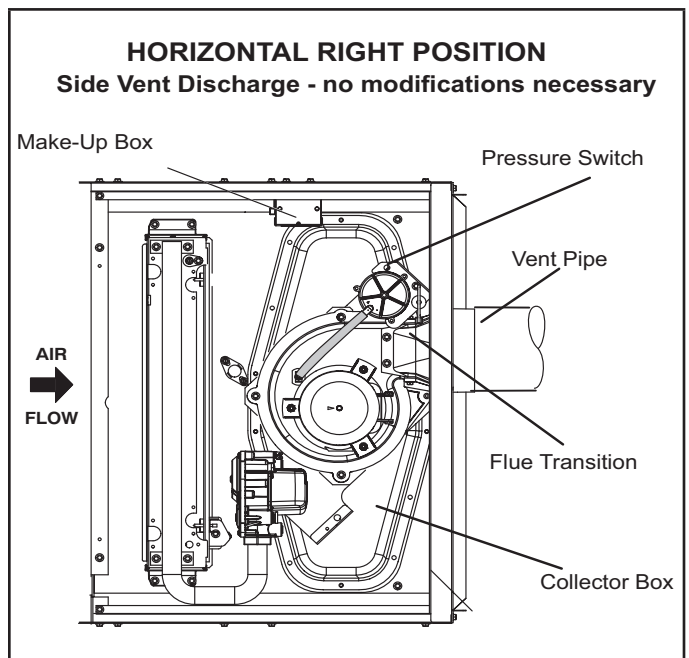

FIGURE 22

The ML180UHV series units are classified as fan-assisted Category I furnaces when vertically vented according to the latest edition of National Fuel Gas Code (NFPA 54 / ANSI Z223.1) in the USA. A fan-assisted Category I furnace is an appliance equipped with an integral mechanical means to either draw or force combustion products through the combustion chamber and/or heat exchanger. The ML180UHV is not approved for use with horizontal venting.

NOTE - Use these instructions as a guide. They do not supersede local codes. This furnace must be vented according to all local codes these installation instructions, and the provided venting tables in these instructions

The venting tables in this manual were extracted from the National Fuel Gas Code (NFPA 54 / ANSI Z223.1) and are provided as a guide for proper vent installation. Proper application, termination, construction and location of vents must conform to local codes having jurisdiction. In the absence of local codes, the NFGC serves as the defining document.

Use self-drilling sheet metal screws or a mechanical fastener to firmly secure the vent pipe to the round collar of the flue transition. If self-drilling screws are used to attach the vent pipe, it is recommended that three be used. Drive one self-drilling screw through the front and one through each side of the vent pipe and collar. See figure 23.

Install the first vent connector elbow at a minimum of six inches (152 mm) from the furnace vent outlet. See figure 23.

! IMPORTANT
Once the venting system is installed, attach the "Disconnected Vent" warning sticker to a visible area of the plenum near the vent pipe. See figure 23. The warning sticker is provided in the bag assembly. Order kit 66W04 for additional stickers.

Venting Using a Masonry Chimney

The following additional requirements apply when a lined masonry chimney is used to vent this furnace.

Masonry chimneys used to vent Category I central furnaces must be either tile-lined or lined with a listed metal lining system or dedicated gas vent. Unlined masonry chimneys are prohibited. See figures 24 and 25 for common venting.

A chimney with one or more sides exposed to the outside of the structure is considered to be an exterior chimney.

An exterior masonry chimney that is not tile-lined must be lined with B1 vent or a listed insulated flexible metal vent. An exterior tile-lined chimney that is sealed and capped may be lined with a listed uninsulated flexible metal vent. If the existing chimney will not accommodate a listed metal liner, either the chimney must be rebuilt to accommodate one of these liners or an alternate approved venting method must be found.

Insulation for the flexible vent pipe must be an encapsulated fiberglass sleeve recommended by the flexible vent pipe manufacturer. See figure 24. Refer to the tables and the venting information contained in these instructions to properly size and install the venting system.

! IMPORTANT
Once the venting system is installed, attach the "Disconnected Vent" warning sticker to a visible area of the plenum near the vent pipe. See figure 23. The warning sticker is provided in the bag assembly. Order kit 66W04 for additional stickers.

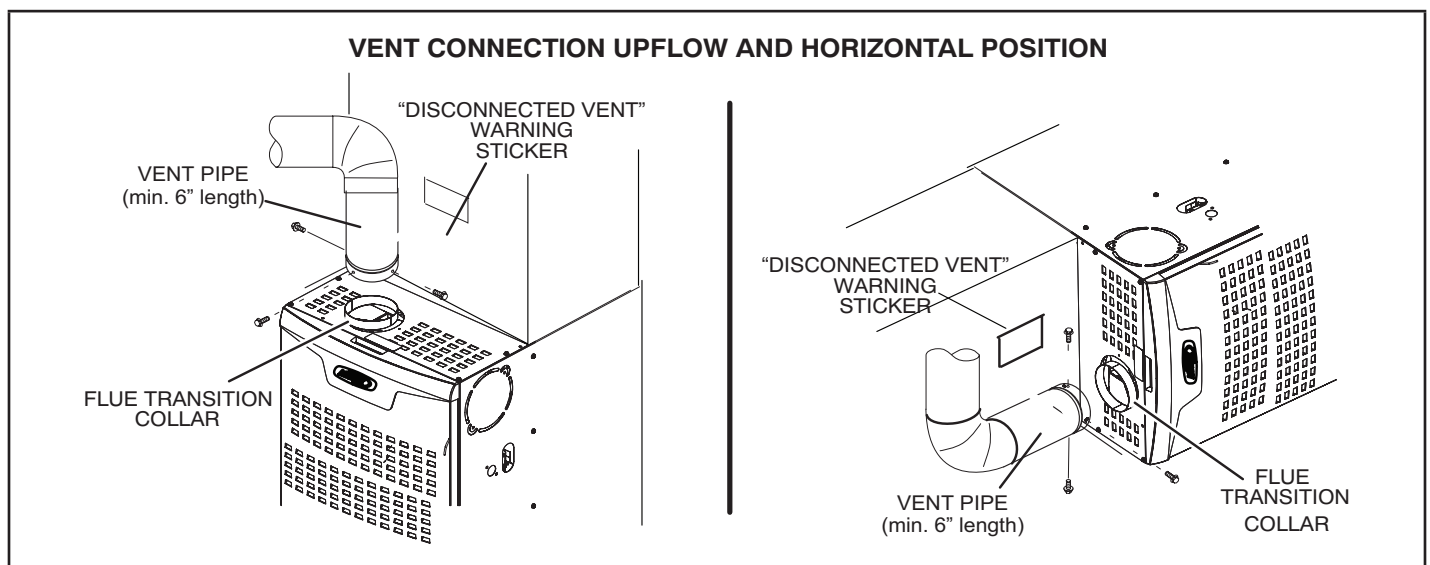

FIGURE 23

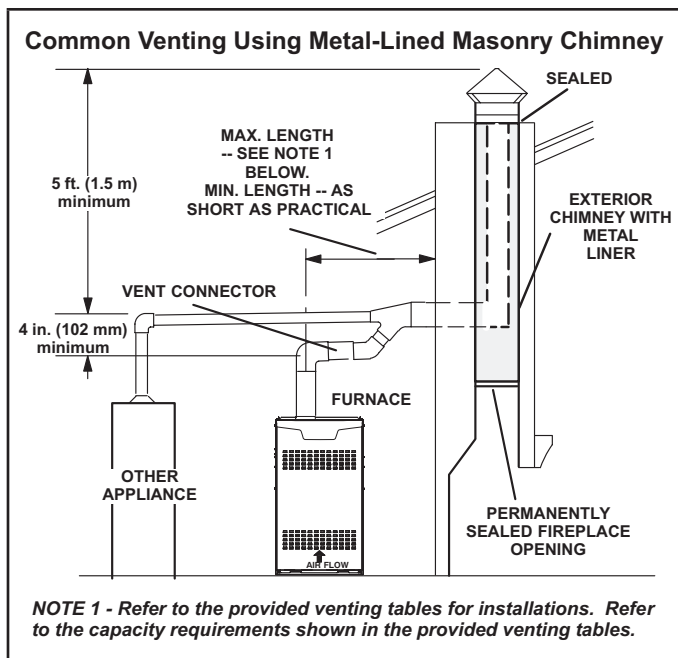

FIGURE 24

DO NOT insulate the space between the liner and the chimney wall with puffed mica or any other loose granular insulating material.

! IMPORTANT
SINGLE appliance venting of a fan-assisted furnace into a tile-lined masonry chimney (interior or outside wall) is PROHIBITED. The chimney must first be lined with either type B1 vent or an insulated single wall flexible vent lining system which has been sized according to the provided venting tables and the vent pipe manufacturer's instructions.

A fan-assisted furnace may be commonly vented into an existing lined masonry chimney if the following conditions are met:

- The chimney is currently serving at least one draft-hood-equipped appliance;
- The vent connectors and chimney are sized according to the provided venting tables.

If type B1 double-wall vent is used inside a chimney, no other appliance can be vented into the chimney. The outer wall of type B1 vent pipe must not be exposed to flue products. A type B1 vent or masonry chimney liner shall terminate above the roof surface with a listed cap or a listed roof assembly according to the terms of their respective listings and the vent manufacturer's instructions.

When inspection reveals that an existing chimney is not safe for the intended purpose, it shall be rebuilt to conform to nationally recognized standards, lined or relined with suitable materials, or replaced with a gas vent or chimney suitable for venting ML180UHV series units. The chimney passageway must be checked periodically to ensure that it is clear and free of obstructions.

Do not install a manual damper, barometric draft regulator, or flue restrictor between the furnace and the chimney.

Never connect a Category I appliance to a chimney that is servicing a solid-fuel appliance. If a fireplace chimney flue is used to vent this appliance, the fireplace opening must be permanently sealed.

A type B or listed chimney lining system that passes through an unused masonry chimney flue is not considered to be exposed to the outdoors.

General Venting Requirements

Vent all ML180UHV furnaces according to these instructions:

- 1 - Vent diameter recommendations and maximum allowable piping runs are found in the provided venting tables.
- 2 - In no case should the vent or vent connector diameter be less than the diameter specified in the provided venting tables.
- 3 - The minimum vent capacity determined by the sizing tables must be less than the low fire input rating and the maximum vent capacity must be greater than the high fire input rating.
- 4 - Single appliance vents - If the vertical vent or tile-lined chimney has a larger diameter or flow area than the vent connector, use the vertical vent diameter to determine the minimum vent capacity and the vent connector diameter to determine the maximum vent capacity. The flow area of the vertical vent, however, shall not exceed 7 times the flow area of the listed appliance categorized vent area, drafthood outlet area or flue collar area unless designed according to approved engineering methods.
- 5 - Multiple appliance vents - The flow area of the largest section of vertical vent or chimney shall not exceed 7 times the smallest listed appliance categorized vent area, drafthood outlet area or flue collar area unless designed
- 6 - The entire length of single wall metal vent connector shall be readily accessible for inspection, cleaning, and replacement.

Common Venting Using Tile-Lined Interior Masonry Chimney and Combined Vent Connector

NOTE- Refer to provided venting tables for installations.

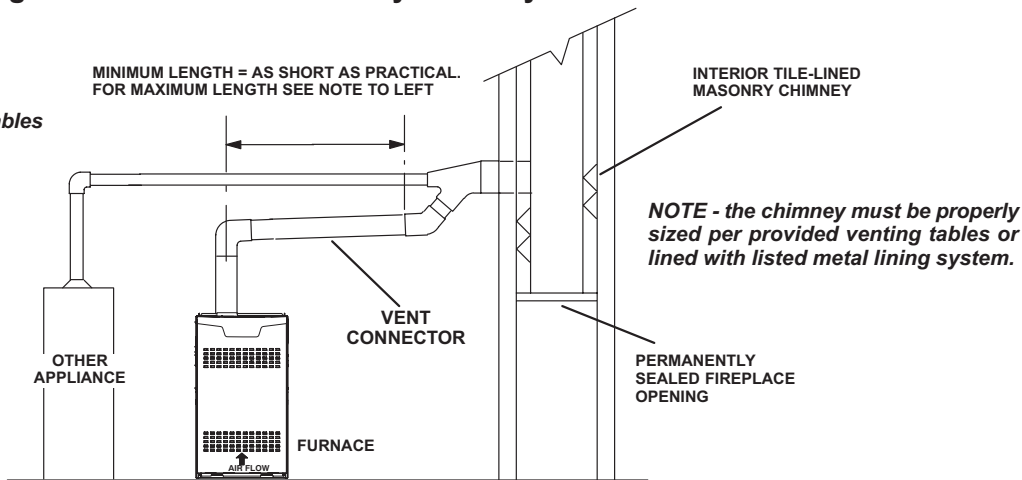

FIGURE 25

- 6 - The entire length of single wall metal vent connector shall be readily accessible for inspection, cleaning, and replacement.
- 7 - Single appliance venting configurations with zero lateral lengths (tables 3) are assumed to have no elbows in the vent system. For all other vent configurations, the vent system is assumed to have two 90° elbows. For each additional 90° elbow or equivalent (for example two 45° elbows equal one 90° elbow) beyond two, the maximum capacity listed in the venting table should be reduced by 10% (0.90 x maximum listed capacity).
- 8 - The common venting tables (4 and 5) were generated using a maximum horizontal vent connector length of 1-1/2 feet (.46 m) for each inch (25 mm) of connector diameter as follows:

TABLE 2

Connector Diameter inches (mm)	Maximum Horizontal Connector Length feet (m)
3 (76)	4-1/2 (1.37)
4 (102)	6 (1.83)
5 (127)	7-1/2 (2.29)
6 (152)	9 (2.74)
7 (178)	10-1/2 (3.20)

- 9 - If the common vertical vent is offset, the maximum common vent capacity listed in the common venting tables should be reduced by 20%, the equivalent of two 90° elbows (0.80 x maximum common vent capacity). The horizontal length of the offset shall not exceed 1-1/2 feet (.46 m) for each inch (25 mm) of common vent diameter.

- 10 - The vent pipe should be as short as possible with the least number of elbows and angles required to complete the job. Route the vent connector to the vent using the shortest possible route.
- 11 - A vent connector shall be supported without any dips or sags and shall slope a minimum of 1/4 inch (6.4 mm) per linear foot (305 mm) of connector, back toward the appliance.
- 12 - Vent connectors shall be firmly attached to the furnace flue collar by self-drilling screws or other approved means, except vent connectors of listed type B vent material which shall be assembled according to the manufacturer's instructions. Joints between sections of single wall connector piping shall be fastened by screws or other approved means.
- 13 - When the vent connector used for Category I appliances must be located in or pass through a crawlspace, attic or other areas which may be cold, that portion of the vent connector shall be constructed of listed double-wall type B vent material or material having equivalent insulation qualities.
- 14 - All venting pipe passing through floors, walls, and ceilings must be installed with the listed clearance to combustible materials and be fire stopped according to local codes. In absence of local codes, refer to NFGC (Z223.1).
- 15 - No portion of the venting system can extend into, or pass through any circulation air duct or plenum.
- 16 - Vent connectors serving Category I appliances shall not be connected to any portion of mechanical draft systems operating under positive pressure such as Category III or IV venting systems.

- 17 - If vent connectors are combined prior to entering the common vent, the maximum common vent capacity listed in the common venting tables must be reduced by 10%, the equivalent of one 90° elbow (0.90 x maximum common vent capacity).
- 18 - The common vent diameter must always be at least as large as the largest vent connector diameter.

- 20 - Do not install a manual damper, barometric draft regulator or flue restrictor between the furnace and the chimney.
- 21 - When connecting this appliance to an existing dedicated or common venting system, you must inspect the venting system's general condition and look for signs of corrosion. The existing vent pipe size must conform to these instructions and the provided venting tables. If the existing venting system does

TABLE 3
Capacity of Type B Double-Wall Vents with Type B Double-Wall Connectors
Serving a Single Category I Appliance

Height H (feet)	Lateral L (feet)	Vent and Connector Diameter - D (inches)							
		3 inch		4 inch		5 inch		6 inch	
		Appliance Input Rating in Thousands of Btu Per Hour							
		Min	Max	Min	Max	Min	Max	Min	Max
6	0	0	78	0	152	0	251	0	375
	2	13	51	18	97	27	157	32	232
	4	21	49	30	94	39	153	50	227
	6	25	46	36	91	47	149	59	223
8	0	0	84	0	165	0	276	0	415
	2	12	57	16	109	25	178	28	263
	5	23	53	32	103	42	171	53	255
	8	28	49	39	98	51	164	64	247
10	0	0	88	0	175	0	295	0	447
	2	12	61	17	118	23	194	26	289
	5	23	57	32	113	41	187	52	280
	10	30	51	41	104	54	176	67	267
15	0	0	94	0	191	0	327	0	502
	2	11	69	15	136	20	226	22	339
	5	22	65	30	130	39	219	49	330
	10	29	59	40	121	51	206	64	315
	15	35	53	48	112	61	195	76	301
20	0	0	97	0	202	0	349	0	540
	2	10	75	14	149	18	250	20	377
	5	21	71	29	143	38	242	47	367
	10	28	64	38	133	50	229	62	351
	15	34	58	46	124	59	217	73	337
	20	48	52	55	116	69	206	84	322
30	0	0	100	0	213	0	374	0	587
	2	9	81	13	166	14	283	18	432
	5	21	77	28	160	36	275	45	421
	10	27	70	37	150	48	262	59	405
	15	33	64	44	141	57	249	70	389
	20	56	58	53	132	66	237	80	374
	30	NA	NA	73	113	88	214	104	346

NOTE - Single appliance venting configurations with zero lateral lengths are assumed to have no elbows in the vent system. For all other vent configurations, the vent system is assumed to have two 90° elbows. For each additional 90° elbow or equivalent (for example two 45° elbows equal one 90° elbow) beyond two, the maximum capacity listed in the venting table should be reduced by 10 percent (0.90 x maximum listed capacity).

TABLE 4

Vent Connector Capacity
Type B Double-Wall Vents with Type B Double-Wall Connectors
Serving Two or More Category I Appliances

Height H (feet)	Lateral L (feet)	Vent and Connector Diameter - D (inches)							
		3 inch		4 inch		5 inch		6 inch	
		Appliance Input Rating in Thousands of Btu Per Hour							
		Min	Max	Min	Max	Min	Max	Min	Max
6	1	22	37	35	66	46	106	58	164
	2	23	41	37	75	48	121	60	183
	3	24	44	38	81	49	132	62	199
8	1	22	40	35	72	49	114	64	176
	2	23	44	36	80	51	128	66	195
	3	24	47	37	87	53	139	67	210
10	1	22	43	34	78	49	123	65	189
	2	23	47	36	86	51	136	67	206
	3	24	50	37	92	52	146	69	220
15	1	21	50	33	89	47	142	64	220
	2	22	53	35	96	49	153	66	235
	3	24	55	36	102	51	163	68	248
20	1	21	54	33	99	46	157	62	246
	2	2	57	34	105	48	167	64	259
	3	23	60	35	110	50	176	66	271
30	1	20	62	31	113	45	181	60	288
	2	21	64	33	118	47	190	62	299
	3	22	66	34	123	48	198	64	309

TABLE 5

Common Vent Capacity
Type B Double-Wall Vents with Type B Double-Wall Connectors
Serving Two or More Category I Appliances

Vent Height H (feet)	Vent and Connector Diameter - D (inches)							
	4 inch		5 inch		7 inch		7 inch	
	Appliance Input Rating in Thousands of Btu Per Hour							
	FAN + FAN	FAN + NAT	FAN + FAN	FAN + NAT	FAN + FAN	FAN + NAT	FAN + FAN	FAN + NAT
6	92	81	140	116	204	161	309	248
8	101	90	155	129	224	178	339	275
10	110	97	169	141	243	194	367	299
15	125	112	195	164	283	228	427	352
20	136	123	215	183	314	255	475	394
30	152	138	244	210	361	297	547	459

Removal of the Furnace from Common Vent

In the event that an existing furnace is removed from a venting system commonly run with separate gas appliances, the venting system is likely to be too large to properly vent the remaining attached appliances.

Conduct the following test while each appliance is operating and the other appliances (which are not operating) remain connected to the common venting system. If the venting system has been installed improperly, you must correct the system as indicated in the general venting requirements section.

IMPORTANT

CARBON MONOXIDE POISONING HAZARD
Failure to follow the steps outlined below for each appliance connected to the venting system being placed into operation could result in carbon monoxide poisoning or death. The following steps shall be followed for each appliance connected to the venting system being placed into operation, while all other appliances connected to the venting system are not in operation:

- 1 - Seal any unused openings in the common venting system.
- 2 - Inspect the venting system for proper size and horizontal pitch. Determine that there is no blockage, restriction, leakage, corrosion, or other deficiencies which could cause an unsafe condition.
- 3 - Close all building doors and windows and all doors between the space in which the appliances remaining connected to the common venting system are located and other spaces of the building. Turn on clothes dryers and any appliances not connected to the common venting system. Turn on any exhaust fans, such as range hoods and bathroom exhausts, so they will operate at maximum speed. Do not operate a summer exhaust fan. Close fireplace dampers.
- 4 - Follow the lighting instructions. Turn on the appliance that is being inspected. Adjust the thermostat so that the appliance operates continuously.
- 5 - After the burner have operated for 5 minutes, test for leaks of flue gases at the draft hood relief opening. Use the flame of a match or candle.
- 6 - After determining that each appliance connected to the common venting system is venting properly, (step 3) return all doors, widows, exhaust fans, fireplace dampers, and any other gas-burning appliances to their previous mode of operation.
- 7 - If a venting problem is found during any of the preceding tests, the common venting system must be modified to correct the problem. Resize the common venting system to the minimum vent pipe size determined by using the appropriate tables in Appendix G. (These are in the current standards of the National Fuel Gas Code ANSI Z223.1.

Gas Piping

Gas supply piping should not allow more than 0.5"W.C. drop in pressure between gas meter and unit. Supply gas pipe must not be smaller than unit gas connection.

CAUTION

If a flexible gas connector is required or allowed by the authority that has jurisdiction, black iron pipe shall be installed at the gas valve and extend outside the furnace cabinet. The flexible connector can then be added between the black iron pipe and the gas supply line.

WARNING

Do not over torque (800 in-lbs) or under torque (350 in-lbs) when attaching the gas piping to the gas valve.

Gas Supply

- 1 - This unit is shipped standard for left or right side installation of gas piping (or top entry in horizontal applications) Connect the gas supply piping into the gas valve. The maximum torque is 800 in lbs and minimum torque is 350 in lbs
- 2 - When connecting the gas supply piping, consider factors such as length of run, number of fittings, and furnace rating to avoid excessive pressure drop. Table 6 lists recommended pipe sizes for typical applications.
- 3 - The gas piping must not run in or through air ducts, clothes chutes, gas vents or chimneys, dumb waiters, or elevator shafts.
- 4 - The piping should be sloped 1/4 inch (6.4 mm) per 15 feet (4.57 m) upward toward the meter from the furnace. The piping must be supported at proper intervals [every 8 to 10 feet (2.44 to 3.01 m)] with suitable hangers or straps. Install a drip leg in vertical pipe runs to the unit.
- 5 - A 1/8" N.P.T. plugged tap or pressure post is located on the gas valve to facilitate test gauge connection. See figure 36.
- 6 - In some localities, codes may require the installation of a manual main shut-off valve and union (furnished by the installer) external to the unit. The union must be of the ground joint type.

IMPORTANT

Compounds used on threaded joints of gas piping must be resistant to the actions of liquified petroleum gases.

NOTE - If emergency shutoff is necessary, shut off the main manual gas valve and disconnect main power to the furnace. The installer should properly label these devices.

TABLE 6
Gas Pipe Capacity - ft³/hr (m³/hr)

Nominal Iron Pipe Size Inches (mm)	Internal Diameter inches (mm)	Length of Pipe - feet (m)									
		10 (3.048)	20 (6.096)	30 (9.144)	40 (12.192)	50 (15.240)	60 (18.288)	70 (21.336)	80 (24.384)	90 (27.432)	100 (30.480)
1/2 (12.7)	.622 (17.799)	172 (4.87)	118 (3.34)	95 (2.69)	81 (2.29)	72 (2.03)	65 (1.84)	60 (1.69)	56 (1.58)	52 (1.47)	50 (1.42)
3/4 (19.05)	.824 (20.930)	360 (10.19)	247 (7.000)	199 (5.63)	170 (4.81)	151 (4.23)	137 (3.87)	126 (3.56)	117 (3.31)	110 (3.11)	104 (2.94)
1 (25.4)	1.049 (26.645)	678 (19.19)	466 (13.19)	374 (10.59)	320 (9.06)	284 (8.04)	257 (7.27)	237 (6.71)	220 (6.23)	207 (5.86)	195 (5.52)
1-1/4 (31.75)	1.380 (35.052)	1350 (38.22)	957 (27.09)	768 (22.25)	657 (18.60)	583 (16.50)	528 (14.95)	486 (13.76)	452 (12.79)	424 (12.00)	400 (11.33)
1-1/2 (38.1)	1.610 (40.894)	2090 (59.18)	1430 (40.49)	1150 (32.56)	985 (27.89)	873 (24.72)	791 (22.39)	728 (20.61)	677 (19.17)	635 (17.98)	600 (17.00)
2 (50.8)	2.067 (52.502)	4020 (113.83)	2760 (78.15)	2220 (62.86)	1900 (53.80)	1680 (47.57)	1520 (43.04)	1400 (39.64)	1300 (36.81)	1220 (34.55)	1160 (32.844)
2-1/2 (63.5)	2.469 (67.713)	6400 (181.22)	4400 (124.59)	3530 (99.95)	3020 (85.51)	2680 (75.88)	2480 (70.22)	2230 (63.14)	2080 (58.89)	1950 (55.22)	1840 (52.10)
3 (76.2)	3.068 (77.927)	11300 (319.98)	7780 (220.30)	6250 (176.98)	5350 (151.49)	4740 (134.22)	4290 (121.47)	3950 (111.85)	3670 (103.92)	3450 (97.69)	3260 (92.31)

NOTE - Capacity given in cubic feet (m³) of gas per hour and based on 0.60 specific gravity gas.

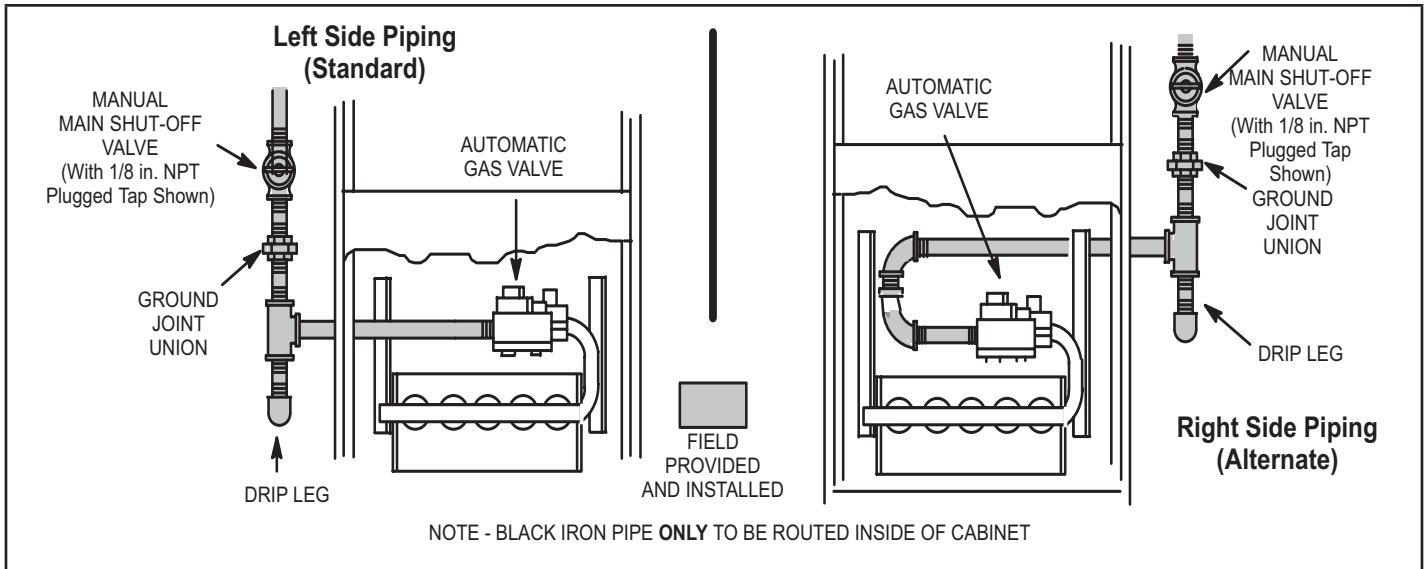

FIGURE 26

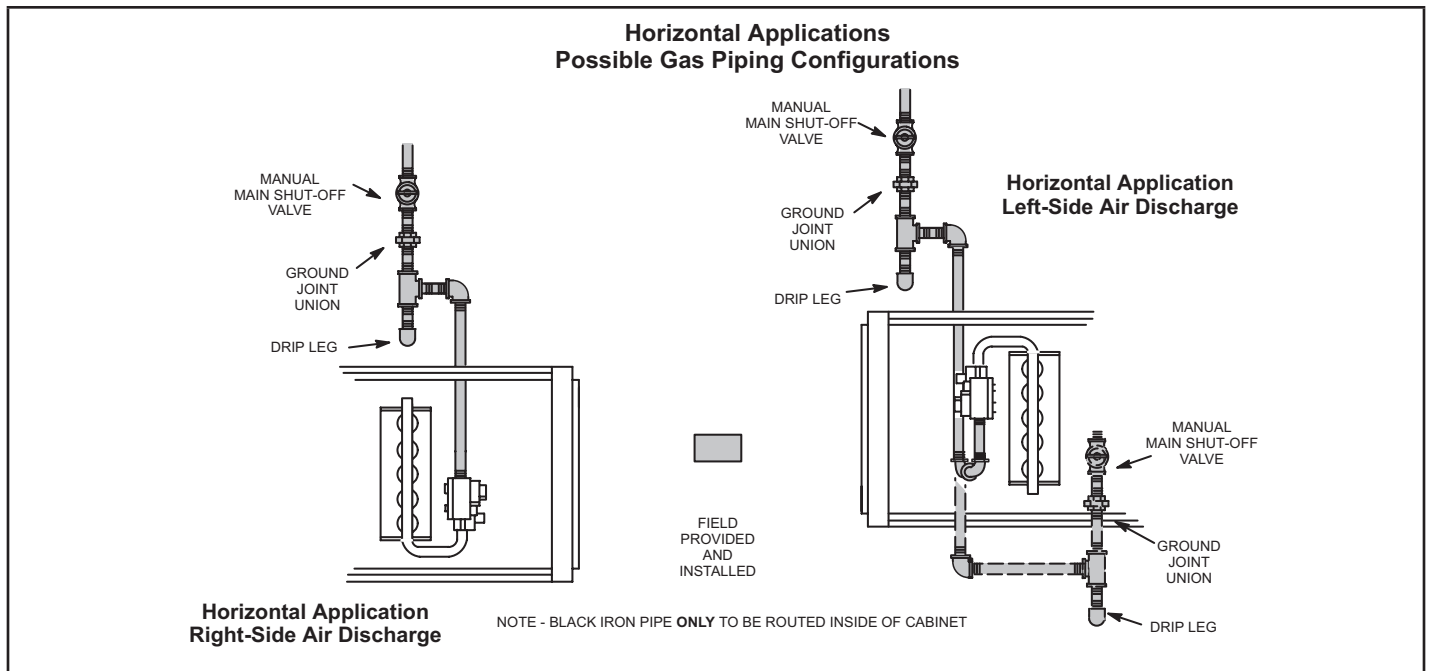

FIGURE 27

Leak Check

After gas piping is completed, carefully check all field-installed piping connections for gas leaks. Use a commercially available leak detecting solution specifically manufactured for leak detection. Never use an open flame to test for gas leaks.

NOTE - If emergency shutoff is necessary, shut off the main manual gas valve and disconnect the main power to the furnace. The installer should properly label these devices.

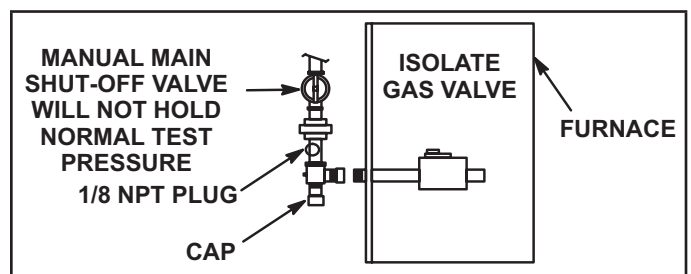

FIGURE 28

⚠ CAUTION

Some soaps used for leak detection are corrosive to certain metals. Carefully rinse piping thoroughly after leak test has been completed. Do not use matches, candles, flame or other sources of ignition to check for gas leaks.

The furnace must be isolated from the gas supply system by closing the individual manual shut-off valve during any gas supply system at pressures greater than or equal to 1/2 psig. (3.48 kPa, 14 inches w.c.). This furnace and its components are designed, manufactured and independently certified to comply with all applicable ANSI/CSA standards. A leak check of the furnace and its components is not required.

⚠ IMPORTANT

When testing gas lines using pressures in excess of 1/2 psig (3.48 kPa), gas valve must be disconnected and isolated. See FIGURE 28. Gas valves can be damaged if subjected to pressures greater than 1/2 psig (3.48 kPa).

Electrical

**ELECTROSTATIC DISCHARGE (ESD)
Precautions and Procedures**

⚠ CAUTION



Electrostatic discharge can affect electronic components. Take precautions to neutralize electrostatic charge by touching your hand and tools to metal prior to handling the control.

The unit is equipped with a field make-up box on the left hand side of the cabinet. The make-up box may be moved to the right side of the furnace to facilitate installation. If the make-up box is moved to the right side, clip the wire ties that bundle the wires together. The excess wire must be pulled into the blower compartment. Secure the excess wire to the existing harness to protect it from damage.

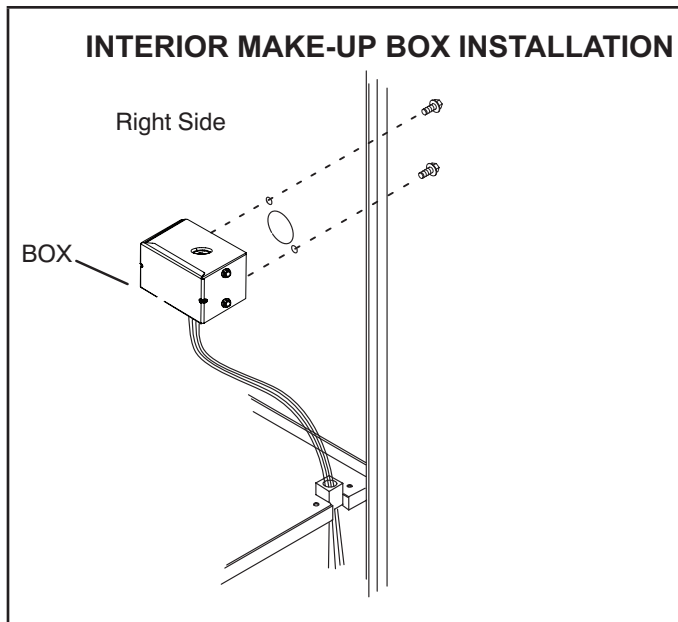

FIGURE 29

Refer to figure 30 for schematic wiring diagram and for field wiring.

The power supply wiring must meet Class I restrictions. Protected by either a fuse or circuit breaker, select circuit protection and wire size according to unit nameplate.

⚠ CAUTION

Failure to use properly sized wiring and circuit breaker may result in property damage. Size wiring and circuit breaker(s) per Product Specifications bulletin (EHB) and unit rating plate.

⚠ WARNING

Fire Hazard. Use of aluminum wire with this product may result in a fire, causing property damage, severe injury or death. Use copper wire only with this product.

NOTE - Unit nameplate states maximum current draw. Maximum over-current protection allowed is 15 AMP.

Holes are on both sides of the furnace cabinet to facilitate wiring.

Install a separate (properly sized) disconnect switch near the furnace so that power can be turned off for servicing. Before connecting the thermostat, check to make sure the wires will be long enough for servicing at a later date. Make sure that thermostat wire is long enough to facilitate future removal of blower for service.

Complete the wiring connections to the equipment. Use the provided unit wiring diagram and the field wiring diagram shown in figure 30. Use 18-gauge wire or larger that is suitable for Class II rating for thermostat connections.

Electrically ground the unit according to local codes or, in the absence of local codes, according to the current National Electric Code (ANSI/NFPA No. 70). A green ground wire is provided in the field make-up box.

NOTE - The ML180UHV furnace contains electronic components that are polarity sensitive. Make sure that the furnace is wired correctly and is properly grounded.

Accessory Terminals

One line voltage “ACC” 1/4” spade terminal is provided on the furnace integrated control. See figure 31 for integrated control configuration. This terminal is energized when the indoor blower is operating. Any accessory rated up to one amp can be connected to this terminal with the neutral leg of the circuit being connected to one of the provided neutral terminals. If an accessory rated at greater than one amp is connected to this terminal, it is necessary to use an external relay.

One line voltage “HUM” 1/4” spade terminal is provided on the furnace integrated control. See figure 31 for integrated control configuration. This terminal is energized in the heating mode when the combustion air inducer is operating. Any humidifier rated up to one amp can be connected to this terminal with the neutral leg of the circuit being connected to one of the provided neutral terminals. If a humidifier rated at greater than one amp is connected to this terminal, it is necessary to use an external relay.

Generator Use - Voltage Requirements

The following requirements must be kept in mind when specifying a generator for use with this equipment:

- The furnace requires 120 volts + 10% (Range: 108 volts to 132 volts).
- The furnace operates at 60 Hz + 5% (Range: 57 Hz to 63 Hz).
- The furnace integrated control requires both polarity and proper ground. Both polarity and proper grounding should be checked before attempting to operate the furnace on either permanent or temporary power.
- Generator should have a wave form distortion of less than 5% total harmonic distortion.

Thermostat

Install the room thermostat according to the instructions provided with the thermostat. If the furnace is being matched with a heat pump, refer to the FM21 installation instruction or appropriate dual fuel thermostat instructions.

Indoor Blower Speeds

- 1 - When the thermostat is set to “FAN ON,” the indoor blower will run continuously at approximately 38% of the second stage cooling speed when there is no cooling or heating demand.
- 2 - When this unit is running in the heating mode, the indoor blower will run on the heating speed designated by the positions of DIP switches 3 and 4.
- 3 - When there is a cooling demand, the indoor blower will run on the cooling speed designated by the positions of DIP switches 5 and 6.

ML180UHV Schematic Wiring Diagram and Sequence of Operation

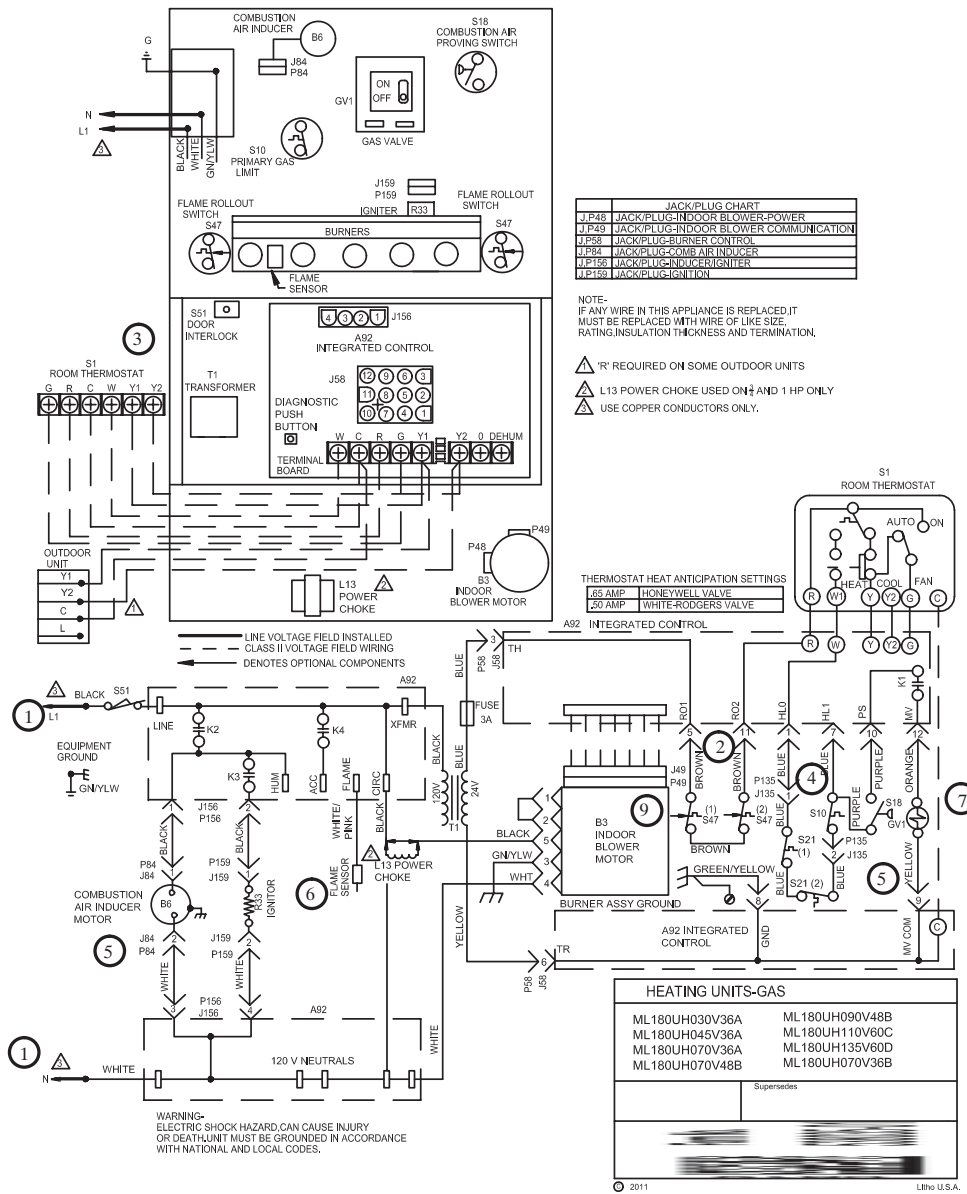

- Line voltage is applied to L1 and N. The T1 low voltage transformer is energized, and line voltage is applied to B3 indoor blower.
- S47 rollout switch(es) must be closed in order for 24V from transformer to be output on integrated control "R" to power thermostat.
- When there is a call for heat, W1 of the thermostat energizes W of the furnace control with 24VAC.
- A92 integrated control runs a self-check. S10 primary limit and S21 secondary limit contacts are found to be closed. Call for heat can continue.
- A92 integrated control energizes B6 combustion air inducer. S18 combustion air pressure switch closes. Once S18 closes, a 15-second pre-purge follows.
- A92 integrated control energizes R33 ignitor. A 20-second warm-up period begins.
- GV1 gas valve opens for a 4-second trial for ignition
- Flame is sensed, gas valve remains open for the heat call.
- After 30-second delay (from flame sensed), A92 integrated control applies 24vVAC to Heat speed of B3 indoor blower.
- When heat demand is satisfied, W1 of the indoor thermostat de-energizes W of A92 ignition control which de-energizes GV1 gas valve. B6 combustion air inducer continues a 5-second post-purge period, and B3 indoor blower completes a selected OFF time delay.

FIGURE 30

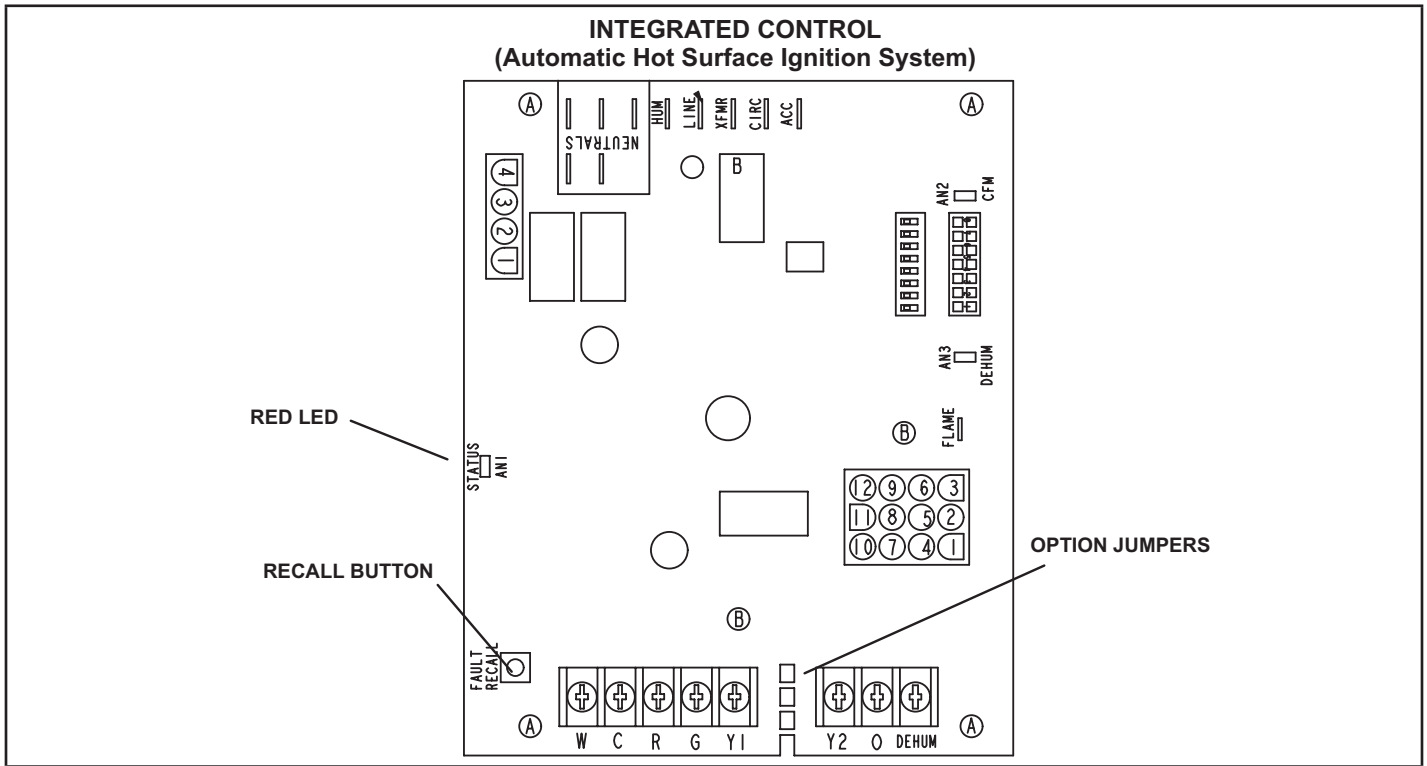

FIGURE 31

TABLE 7

1/4" QUICK CONNECT TERMINALS	
HUM	Humidifier 120VAC
LINE	120VAC
XFMR	Transformer 120VAC
CIRC	Indoor blower 120VAC
ACC	Indoor air quality accessory 120VAC
NEUTRAL	Common 120VAC
3/16" QUICK CONNECT TERMINALS	
Flame	Flame sense

Integrated Control Diagnostic Codes

RED LED Flash Code	Diagnostic Codes / Status of Furnace
Off	No power to control or board fault detected
On	Board fault detected,
Heartbeat ¹	Normal Operation - Idle, Continuous Fan, Cool
Continuous Rapid Flash ²	Call For Heat / Burner Operation
1	Reverse Line Voltage Polarity
2	Improper Earth Ground
3	Burner failed to light, or lost flame during heat demand
4	Low Flame Signal - check flame sensor
5	Watchguard - burner failed to light, exceeded maximum number of retries or recycles.
6	Not Used
7	Primary or Secondary Limit Open or Watchguard Mode - Limit Switch Open longer than 3 minutes
8	Rollout Switch Open
9	Pressure Switch failed to close or opened during heat demand
10	Watchguard - Pressure Switch opened 5 times during one heat demand
11	Pressure Switch stuck closed prior to activation of combustion air inducer
12	Flame Sensed without gas valve energized
13	Low Line Voltage
Notes	
Note - 1	A "Heartbeat" is indicated by a "Slow Flash" - 1 sec on 1 sec off, repeating
Note - 2	A "Rapid Flash" is indicated by a 1/3 second on, 1/3 second off, repeating
Note	Error codes are indicated by a "rapid flash" - the LED flashes X times at 1/3 second on 1/3 second off, remains off for 3 seconds then repeats.
Note	Last 5 error codes are stored in memory including when power is shut off to the unit. - To recall, press and release button, most recent will be displayed first, LED off for 3 sec, then next error code is displayed, etc. To clear error codes, depress and hold button longer than 5 seconds.

Variable Speed Features

This furnace is equipped with a variable speed circulation air blower motor that will deliver a constant airflow within a wide range of external static pressures. Other features of this variable speed motor include:

- **Soft Start** - The variable speed motor will slowly ramp up to normal operating speed. This minimizes noise and increases comfort by eliminating the initial blasts of air encountered with standard motors.
- **Soft Stop** - At the end of a cooling or heating cycle, the variable speed motor will slowly ramp down after a short blower “off” delay. If continuous blower operation has been selected, the variable speed motor will slowly ramp down until it reaches the airflow for that mode.
- **Passive Dehumidification** - For situations where humidity control is a problem, a dehumidification feature has been built into the variable speed motor. At the start of each cooling cycle, the variable speed motor will run at 82% of the rated airflow for 7.5 minutes. After 7.5 minutes has elapsed, the motor will increase to 100% of the rated airflow.
- **Active Dehumidification** - To achieve additional dehumidification, clip the jumper located near the DEHUM terminal on the integrated ignition/ blower control board and connect a humidity control that opens on humidity rise to the DEHUM and R terminals. The DEHUM terminal on the control board must be connected to the normally closed contact of the humidity control so that the board senses an open circuit on high humidity. In this setup, the variable speed motor will operate at a 30% reduction in the normal cooling airflow rate when there is a call for dehumidification.

Both the passive and active dehumidification methods described above can be utilized on the same furnace.

Circulating Airflow Adjustments

Heating Mode - These units are factory set to run at the middle of the heating rise range as shown on the unit rating plate. See table 16 for allowable heating speeds. If higher or lower rise is desired, reposition DIP switches 3 and 4. To determine what CFM the motor is delivering at any time, count the number of times the green LED on the control board flashes. Each flash signifies 100 CFM; count the flashes and multiply by 100 to determine the actual CFM delivered (for example: 10 flashes x 100 = 1000 CFM).

TABLE 8
Heating Mode

Heat Air Flow	DIP3	DIP4
High	OFF	ON
Med-High	ON	OFF
Med-Low	OFF	OFF
Low	ON	ON

Cooling Mode - The units are factory set for the highest airflow for each model. Adjustments can be made to the cooling airflow by repositioning DIP switches 5 and 6. To determine what CFM the motor is delivering at any time, count the number of times the green LED on the control board flashes. Each flash signifies 100 CFM; count the flashes and multiply by 100 to determine the actual CFM delivered (for example: 10 flashes x 100 = 1000 CFM).

TABLE 9
Cooling Mode

Cool Air Flow	DIP5	DIP6
High	OFF	OFF
Med-High	OFF	ON
Med-Low	ON	OFF
Low	ON	ON

Adjust Tap - Airflow amounts may be increased or decreased by 10% by moving the ADJUST DIP switches 7 and 8 from the NORM position to the (+) or (-) position. Changes to the ADJUST tap will affect both cooling and heating airflows. The TEST position on the ADJUST tap is not used.

TABLE 10
Adjust Tap

Adjust Tap	DIP7	DIP8
10%	ON	OFF
Normal	OFF	OFF
-10%	OFF	ON
Not Used	ON	ON

Continuous Blower Operation Figure 32

The comfort level of the living space can be enhanced when using this feature by allowing continuous circulation of air between calls for cooling or heating. The circulation of air occurs at 38% the full cooling airflow rate.

To engage the continuous blower operation, place the fan switch on the thermostat into the ON position. A call for fan from the thermostat closes R to G on the ignition control board. The control waits for a 1 second thermostat debounce delay before responding to the call for fan by ramping the circulating blower up to the cooling speed. When the call for continuous fan is satisfied, the control immediately ramps down the circulating blower.

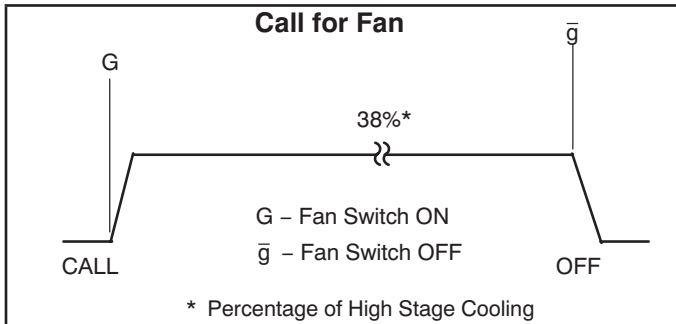

FIGURE 32

Single Stage Cooling Figure 33

A call for cooling from the thermostat closes the R to Y circuit on the integrated ignition/blower control board. The control waits for a 1-second delay before energizing the circulating blower to 82% of the selected cooling CFM (passive dehumidification mode). After 7.5 minutes, the circulating blower automatically ramps up to 100% of the selected cooling airflow. When the call for cooling is satisfied, the circulating blower ramps back down to 82% of the selected cooling airflow for 1 minute, then shuts off.

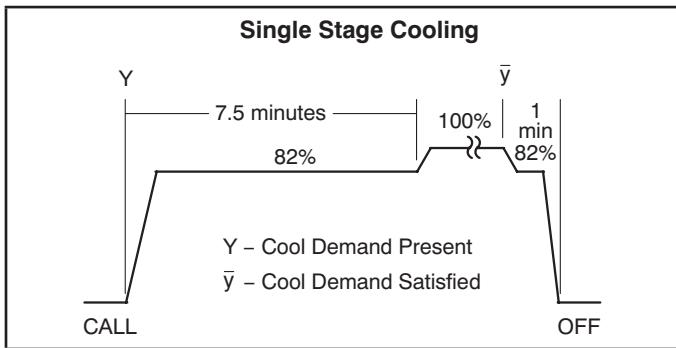

FIGURE 33

Two Stage Cooling Figure 34

A call for 1st stage cooling from the thermostat closes the R to Y circuit on the control board. The control waits for a 1- second delay before energizing the circulating blower. The blower motor runs at 57% of the selected air flow for the first 7.5 minutes of the 1st stage cooling demand (passive dehumidification mode). After 7.5 minutes, the blower motor runs at 70% of the selected cooling air flow until 1st stage cooling demand is satisfied.

A call for 2nd stage cooling from the thermostat closes the R to Y2 circuit on the control board. The blower motor ramps up to 100% of the selected cooling air flow. When the demand for cooling is met, the blower ramps down to Y1 until satisfied, then ramps down to 57% for 1 minute, then turns off.

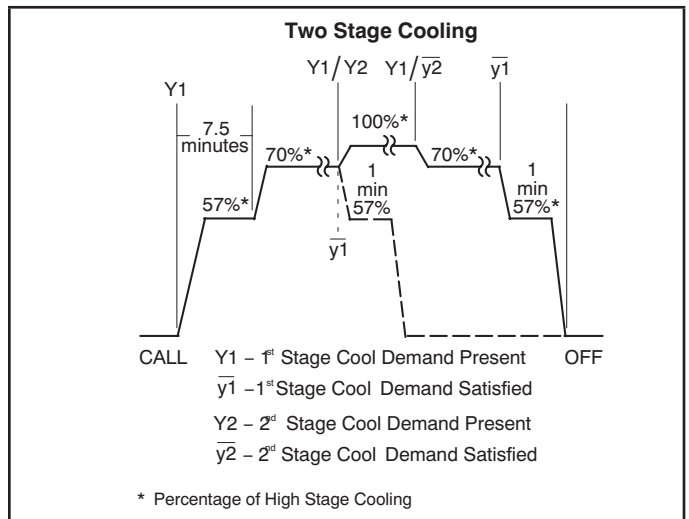

FIGURE 34

Heat Pump

For heat pump operation, clip the R-O link located next to the terminal block at the bottom of the furnace control. In heat pump mode, a call for heat will result in the circulating air blower operating at the selected cooling airflow after a brief ramp-up period.

Unit Start-Up

FOR YOUR SAFETY READ BEFORE LIGHTING

⚠ WARNING

Do not use this furnace if any part has been underwater. A flood-damaged furnace is extremely dangerous. Attempts to use the furnace can result in fire or explosion. Immediately call a qualified service technician to inspect the furnace and to replace all gas controls, control system parts, and electrical parts that have been wet or to replace the furnace, if deemed necessary.

⚠ WARNING

If overheating occurs or if gas supply fails to shut off, shut off the manual gas valve to the appliance before shutting off electrical supply..

⚠ CAUTION

Before attempting to perform any service or maintenance, turn the electrical power to unit OFF at disconnect switch..

BEFORE LIGHTING smell all around the appliance area for gas. Be sure to smell next to the floor because some gas is heavier than air and will settle on the floor.

The gas valve on the ML180UHV unit is equipped with a gas control switch. Use only your hand to move the switch. Never use tools. If the switch will not turn or if the control switch will not move by hand, do not try to repair it.

Placing the furnace into operation:

ML180UHV units are equipped with an automatic ignition system. Do not attempt to manually light burners on these furnaces. Each time the thermostat calls for heat, the burners will automatically light. The ignitor does not get hot when there is no call for heat on units with an automatic ignition system.

⚠ WARNING

If you do not follow these instructions exactly, a fire or explosion may result causing property damage, personal injury or death..

Gas Valve Operation (Figures 35 and 36)

- 1 - **STOP!** Read the safety information at the beginning of this section.
- 2 - Set the thermostat to the lowest setting.
- 3 - Turn off all electrical power to the unit.
- 4 - This furnace is equipped with an ignition device which automatically lights the burners. Do not try to light the burners by hand.

- 5 - Remove the upper access panel.
- 6 - Move switch on gas valve to OFF. Do not force. See figures 35 and 36.
- 7 - Wait five minutes to clear out any gas. If you then smell gas, **STOP!** Immediately call your gas supplier from a neighbor's phone. Follow the gas supplier's instructions. If you do not smell gas go to next step.

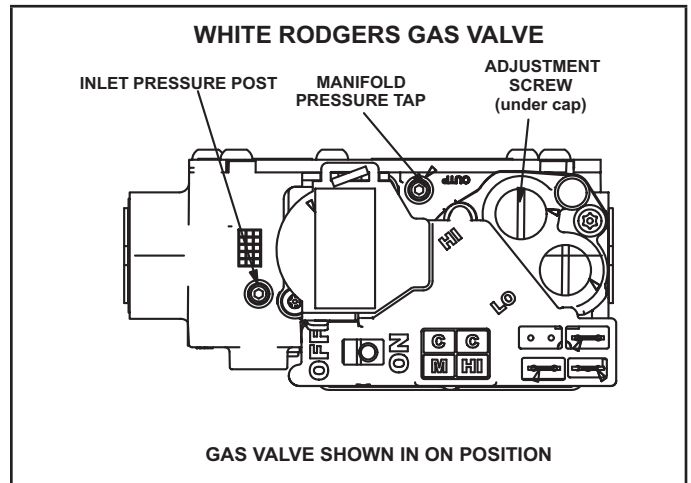

FIGURE 35

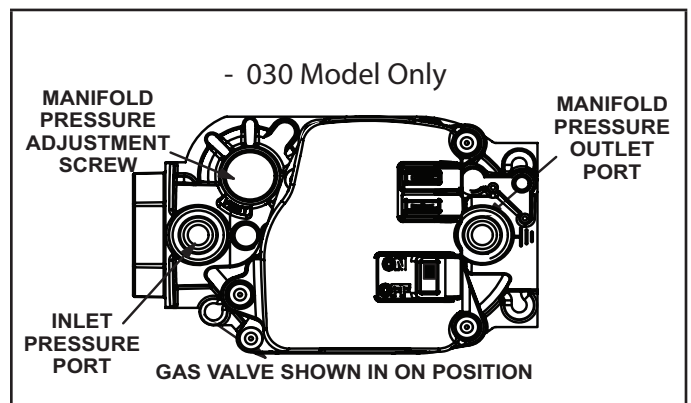

FIGURE 36

- 8 - Move switch on gas valve to ON. Do not force. See figures 35 and 36.
 - 9 - Replace the upper access panel.
 - 10- Turn on all electrical power to to the unit.
 - 11- Set the thermostat to desired setting.
- NOTE - When unit is initially started, steps 1 through 11 may need to be repeated to purge air from gas line.
- 12- If the appliance will not operate, follow the instructions "Turning Off Gas to Unit" and call your service technician or gas supplier.

Turning Off Gas to Unit

- 1 - Set the thermostat to the lowest setting.
- 2 - Turn off all electrical power to the unit if service is to be performed.
- 3 - Remove the upper access panel.
- 4 - Move switch on gas valve to OFF. Do not force.
- 5 - Replace the upper access panel.

Failure To Operate

If the unit fails to operate, check the following:

- 1 - Is the thermostat calling for heat?
- 2 - Are access panels securely in place?
- 3 - Is the main disconnect switch closed?
- 4 - Is there a blown fuse or tripped circuit breaker?
- 5 - Is the filter dirty or plugged? Dirty or plugged filters will cause the limit control to shut the unit off.
- 6 - Is gas turned on at the meter?
- 7 - Is the manual main shut-off valve open?
- 8 - Is the internal manual shut-off valve open?
- 9 - Is the unit ignition system in lock out? If the unit locks out again, call the service technician to inspect the unit for blockages.
- 10 - Is pressure switch closed? Obstructed flue will cause unit to shut off at pressure switch. Check flue and outlet for blockages
- 11 - Are flame rollout switches tripped? If flame rollout switches are tripped, call the service technician for inspection.

Heating Sequence Of Operation (follow steps below or see Figure 30 for more detail).

- 1 - When thermostat calls for heat, combustion air blower starts.
- 2 - Combustion air pressure switch proves blower operation. Switch is factory-set and requires no adjustment.
- 3 - After a 15-second prepurge, the hot surface ignitor energizes.
- 4 - After a 20-second ignitor warm-up period, the gas valve solenoid opens. A 4-second trial for ignition period begins.
- 5 - Gas is ignited, flame sensor proves the flame, and the combustion process continues.
- 6 - If flame is not detected after first ignition trial, the ignition control will repeat steps 3 and 4 four more times before locking out the gas valve ("WATCHGUARD" flame failure mode). The ignition control will then automatically repeat steps 1 through 6 after 60 minutes.
- 7 - To interrupt the 60-minute "WATCHGUARD" period, move thermostat from "Heat" to "OFF" then back to "Heat." Heating sequence then restarts at step 1.

Gas Pressure Adjustment

Gas Flow (Approximate)

Furnace should operate at least 5 minutes before checking gas flow. Determine time in seconds for **two** revolutions of gas through the meter. (Two revolutions assures a more accurate time.) **Divide by two** and compare to time in table 11. If manifold pressure matches table 13 and rate is incorrect, check gas orifices for proper size and restriction. Remove temporary gas meter if installed.

NOTE - To obtain accurate reading, shut off all other gas appliances connected to meter.

TABLE 11

GAS METER CLOCKING CHART				
ML180UHV Unit	Seconds For One Revolution			
	Natural		LP/Propane	
	1 cu ft Dial	2 cu ft Dial	1 cu ft Dial	2 cu ft Dial
-030	115	230	285	575
-045	80	160	200	400
-070	55	110	136	272
-090	41	82	102	204
-110	33	66	82	164
-135	27	54	68	136

Natural-1000 btu/cu ft LP-2500 btu/cu ft

Supply Pressure Measurement

A threaded plug on the inlet side of the gas valve provides access to the supply pressure tap. Remove the threaded plug, install a field-provided barbed fitting and connect a manometer to measure supply pressure. See table 13 for proper line pressure. Replace the threaded plug after measurements have been taken.

Manifold Pressure Measurement

NOTE - Pressure test adapter kit (10L34) is available from Lennox to facilitate manifold pressure measurement.

- 1 - Connect test gauge to manifold pressure post on gas valve.
- 2 - Fire the unit on and let run for 5 minutes to allow for steady state conditions.
- 3 - After allowing unit to stabilize for 5 minutes, record manifold pressure and compare to value given in table 13.
- 4 - If necessary, make adjustments. Figures 35 and 36 show location of adjustment screw.
- 5 - Shut unit off and remove manometer as soon as an accurate reading has been obtained. Take care to replace pressure tap plug if removed.
- 6 - Start unit and perform leak check. Seal leaks if found.

Proper Combustion

Furnace should operate a minimum 15 minutes with correct manifold pressure and gas flow rate before checking combustion. Take combustion sample beyond the flue outlet and compare to the tables below. The maximum carbon monoxide reading should not exceed 100 ppm.

TABLE 12

ML180UHV Unit	CO ₂ % Nat	CO ₂ % LP
All Models	6.8 - 7.4	7.5 - 9.0

High Altitude

The manifold pressure may require adjustment and combustion air pressure switch may need replacing to ensure proper combustion at higher altitudes. Refer to table 13 for manifold pressure and table 14 for pressure switch change and gas conversion kits.

⚠ IMPORTANT

For safety, shut unit off and remove manometer as soon as an accurate reading has been obtained. Take care to replace pressure tap plug.

TABLE 13

Supply Line and Manifold Pressure Settings at all Altitudes

Model Input Size	Gas	0 - 2000 ft.	2001 -4500 ft .	4501 - 7500 ft.	7501 - 10,000 ft	Line Pressure in. wg.	
						Min	Max
030	Nat	3.5	3.2	3.0	3.5	4.5	13.0
	LP/Propane	10.0	10.0	10.0	10.0	11.0	13.0
045	Nat	3.5	3.2	3.0	3.5	4.5	13.0
	LP/Propane	10.0	10.0	10.0	10.0	11.0	13.0
070	Nat	3.5	3.2	2.8	3.5	4.5	13.0
	LP/Propane	10.0	10.0	10.0	10.0	11.0	13.0
090	Nat	3.5	3.2	2.7	3.5	4.5	13.0
	LP/Propane	10.0	10.0	9.6	10.0	11.0	13.0
110	Nat	3.5	3.5	3.0	3.5	4.5	13.0
	LP/Propane	10.0	10.0	9.6	10.0	11.0	13.0

TABLE 14

Pressure Switch and Gas Conversion Kits at all Altitudes

Model Input Size	High Altitude Pressure Switch Kit			High Altitude Natural Gas Orifice Kit	LP/Propane Orifice Kit		Natural Gas Orifice Kit
	0-4500 ft	4501-7500 ft	7501 - 10,000 ft	7501- 10,000 ft	0-7500 ft	7501-10,000 ft	0-7500 ft
030	No Change	80W52	80W51	14C90	19D59	19H30	N/A
045		80W52	80W51	73W37	19D58	19H29	77WO9
070		80W52	80W51				
110		80W52	80W51				
090		80W52	80W51				
110		80W57	80W52				

NOTE - A natural to L.P. propane gas changeover kit is necessary to convert this unit. Refer to the changeover kit installation instruction for the conversion procedure.

Other Unit Adjustments

Primary and Secondary Limits

The primary limit is located on the heating compartment vestibule panel. The secondary limits (if equipped) are located in the blower compartment, attached to the back side of the blower. These auto reset limits are factory-set and require no adjustment.

Flame Rollout Switches

These manually reset switches are located on the burner box.

Pressure Switch

The pressure switch is located in the heating compartment adjacent to the combustion air inducer. The switch checks for proper combustion air inducer operation before allowing ignition trial. The switch is factory-set and requires no adjustment.

Temperature Rise

After the furnace has been started, and supply and return air temperatures have been allowed to stabilize, check the temperature rise. If necessary, adjust the blower speed to maintain the temperature rise within the range shown on the unit nameplate. See table 16 for allowable heating speeds. Increase the blower speed to decrease the temperature. Decrease the blower speed to increase the temperature rise. Failure to adjust the temperature rise may cause erratic limit operation.

Fan Control

The heat fan-on time of 30 seconds is not adjustable. The heat fan-off delay (amount of time that the blower operates after the heat demand has been satisfied) may be adjusted by repositioning DIP switches 1 and 2 (table 15). The unit is shipped with a factory fan-off delay setting of 90 seconds. The fan-off delay affects comfort and is adjustable to satisfy individual applications. Adjust the fan-off delay to achieve a supply air temperature between 90° and 110°F at the moment that the blower is de-energized. Longer off delay settings provide lower return air temperatures; shorter settings provide higher return air temperatures.

TABLE 15

Heat Blower Off Delay Seconds	DIP1	DIP2
90	OFF	OFF
120	ON	OFF
180	ON	ON
210	OFF	ON

Thermostat Heat Anticipation

Set the heat anticipator setting (if adjustable) according to the amp draw listed on the wiring diagram that is attached to the unit.

Electronic Ignition

The integrated control has an added feature of an internal Watchguard control. The feature serves as an automatic reset device for integrated control lockout caused by ignition failure. This type of lockout is usually due to low gas line pressure. After one hour of continuous thermostat demand for heat, the Watchguard will re-set and remake thermostat demand to the furnace and automatically reset the integrated control to begin the ignition sequence.

Cooling

The unit is set up at the factory for single stage cooling. For two stage cooling operation, clip the Y1 to Y2 link located next to the terminal block at the bottom of the furnace control. If the active dehumidification feature is enabled, the circulating blower runs at 82% of the selected cooling speed as long as there is a call for dehumidification.

IMPORTANT

The system cannot be in the passive mode or dehumidification mode when charging the cooling system.

Service

WARNING

The blower access panel must be securely in place when the blower and burners are operating. Gas fumes, which could contain carbon monoxide, can be drawn into living space resulting in personal injury or death.

WARNING

ELECTRICAL SHOCK, FIRE, OR EXPLOSION HAZARD.

Failure to follow safety warnings exactly could result in dangerous operation, serious injury, death or property damage.

Improper servicing could result in dangerous operation, serious injury, death, or property damage. Before servicing, disconnect all electrical power to furnace.

When servicing controls, label all wires prior to disconnecting. Take care to reconnect wires correctly. Verify proper operation after servicing.

Annual Furnace Maintenance

At the beginning of each heating season, and to comply with the Lennox Limited Warranty, your system should be checked by a licensed professional technician (or equivalent) as follows:

- 1 - Check wiring for loose connections, voltage at indoor unit and amperage of indoor motor.
- 2- Check the condition of the belt and shaft bearings if applicable.
- 3- Inspect all gas pipe and connections for leaks.
- 4- Check the cleanliness of filters and change if necessary (monthly).
- 5- Check the condition and cleanliness of burners and heat exchanger and clean if necessary.
- 6- Check the cleanliness of blower assembly and clean the housing, blower wheel and blower motor if necessary . The blower motors are prelubricated for extended bearing life. No further lubrication is needed.
- 7- Inspect the combustion air inducer and clean if necessary.
- 8- Evaluate the heat exchanger integrity by inspecting the heat exchanger per the AHRI heat exchanger inspection procedure. This procedure can be viewed at www.ahrinet.org
- 9- Ensure sufficient combustion air is available to the furnace. Fresh air grilles and louvers (on the unit and in the room where the furnace is installed) must be properly sized, open and unobstructed to provide combustion air.
- 10-Inspect the furnace venting system to make sure it is in place, structurally sound, and without holes, corrosion, or blockage. Vent system must be free and clear of obstructions and must slope upward away from the furnace . Vent system should be installed per the National Fuel Gas Code

- 11- Inspect the furnace return air duct connection to ensure the duct is sealed to the furnace. Check for air leaks on supply and return ducts and seal where necessary.
- 12- Check the condition of the furnace cabinet insulation and repair if necessary.
- 13- Perform a complete combustion analysis during the furnace inspection to ensure proper combustion and operation. Consult Service Literature for proper combustion values.
- 14-Verify operation of CO detectors and replace batteries as required.

Perform a general system test. Turn on the furnace to check operating functions such as the start-up and shut-off operation.

- 1 - Check the operation of the ignition system, inspect and clean flame sensor. Check microamps before and after. Check controls and safety devices (gas valve, flame sensor, temperature limits). Consult Service Manual for proper operating range. Thermal Limits should be checked by restricting airflow and not disconnecting the indoor blower. For additional details, please see Service and Application Note H049.
- 2 - Verify that system total static pressure and airflow settings are within specific operating parameters.
- 3 - Clock gas meter to ensure that the unit is operating at the specified firing rate. Check the supply pressure and the manifold pressure. On two-stage gas furnaces check the manifold pressure on high fire and low fire. If manifold pressure adjustment is necessary, consult the Service Literature for unit specific information on adjusting gas pressure. Not all gas valves are adjustable. Verify correct temperature rise.

Cleaning the Burners

NOTE - Use papers or protective covering in front of the furnace during cleaning.

- 1 - Turn off both electrical and gas power supplies to furnace.
- 2 - Label the wires from gas valve, rollout switches, primary limit switch and make-up box then disconnect them.
- 3 - Disconnect gas supply piping. Remove the screw securing the burner box cover and remove cover. Remove the four screws securing the burner manifold assembly to the vestibule panel and remove the assembly from the unit.

4 - To clean burners, run a vacuum cleaner with a soft brush attachment over the face of burners. Visually inspect inside the burners and crossovers for any blockage caused by foreign matter. Remove any blockage. Figure 37 shows burner detail.

5 - Reinstall burner box, manifold assembly and burner box cover.

6 - Re-install gas supply and turn on electrical power to furnace.

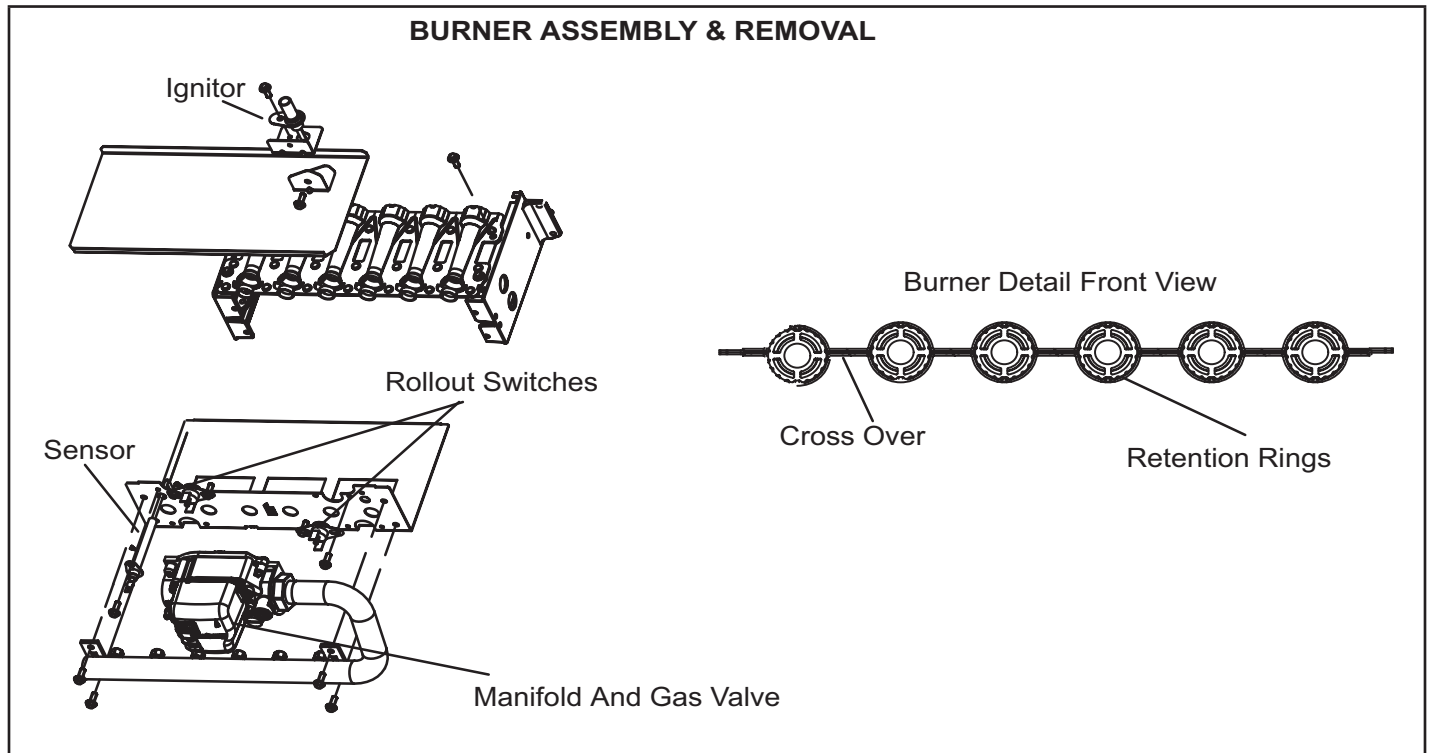

FIGURE 37

TABLE 16
Allowable Heating Speeds

ML180V Model	Speed Adjust	LOW	MED LOW	MED HIGH	HIGH						
030V36A	+10%	Allowed	Allowed	Allowed	Allowed						
	Norm		Factory Setting								
	-10%		Allowed								
045V36A	+10%		Allowed		Allowed	Not Allowed					
	Norm		Factory Setting								
	-10%		Allowed								
070V36A	+10%		Allowed			Allowed	Not Allowed				
	Norm		Factory Setting								
	-10%		Allowed								
070V36B	+10%		Allowed				Allowed	Allowed	Allowed		
	Norm						Factory Setting				
	-10%						Allowed				
070V48B	+10%						Allowed			Allowed	Allowed
	Norm						Factory Setting				
	-10%						Allowed				
090V48B	+10%	Allowed		Allowed			Allowed				
	Norm	Factory Setting									
	-10%	Allowed									
110V60C	+10%	Allowed			Allowed		Allowed		Allowed		
	Norm				Factory Setting						
	-10%				Allowed						

TABLE 17
Allowable Circulation Speeds

Model Number	38% of Second Stage Cooling
All Models	Factory Setting

BLOWER DATA**ML180UH030V36A BLOWER PERFORMANCE (less filter)****BOTTOM RETURN AIR**

0 through 0.8 in. w.g. (Heating) and 0 through 1.0 in. w.g. (Cooling) External Static Pressure Range

"ADJUST" Switch Positions	Speed Switch Positions							
	"HEAT" Speed - cfm				Second Stage "COOL" Speed - cfm			
	Low	¹ Med-Low	Med-Hi	High	Low	Med-Low	Med-Hi	¹ High
+	630	665	715	775	645	840	1045	1320
¹ NORM	580	615	665	715	590	765	950	1200
—	335	560	615	645	540	700	850	1070
"ADJUST" Switch Positions					First Stage "COOL" Speed - cfm			
					Low	Med-Low	Med-Hi	¹ High
					450	580	690	860
+					410	520	635	785
¹ NORM					380	480	590	705
—								

¹ Factory default DIP switch setting.

NOTES - The effect of static pressure is included in air volumes shown.

First stage COOL (two-stage air conditioning units only) is approximately **70%** of the same second stage COOL speed position.Continuous Fan Only speed is approximately **38%** of the same second stage COOL speed position - minimum 350 cfm.

Lennox Harmony III™ Zoning System Applications - Minimum blower speed is 350 cfm.

BLOWER DATA**ML180UH045V36A BLOWER PERFORMANCE (less filter)****BOTTOM RETURN AIR**

0 through 0.8 in. w.g. (Heating) and 0 through 1.0 in. w.g. (Cooling) External Static Pressure Range

"ADJUST" Switch Positions	Speed Switch Positions							
	"HEAT" Speed - cfm				Second Stage "COOL" Speed - cfm			
	Low	¹ Med-Low	Med-Hi	High	Low	Med-Low	Med-Hi	¹ High
+	900	1005	1100	1260	645	840	1045	1320
¹ NORM	825	915	1005	1135	590	765	950	1200
—	750	830	910	1020	540	700	850	1070
"ADJUST" Switch Positions					First Stage "COOL" Speed - cfm			
					Low	Med-Low	Med-Hi	¹ High
					450	580	690	860
+					410	520	635	785
¹ NORM					380	480	590	705
—								

¹ Factory default DIP switch setting.

NOTES - The effect of static pressure is included in air volumes shown.

First stage COOL (two-stage air conditioning units only) is approximately **70%** of the same second stage COOL speed position.Continuous Fan Only speed is approximately **38%** of the same second stage COOL speed position - minimum 350 cfm.

Lennox Harmony III™ Zoning System Applications - Minimum blower speed is 350 cfm.

BLOWER DATA**ML180UH070V36A BLOWER PERFORMANCE (less filter)****BOTTOM RETURN AIR****0 through 0.8 in. w.g. (Heating) and 0 through 1.0 in. w.g. (Cooling) External Static Pressure Range**

"ADJUST" Switch Positions	Speed Switch Positions							
	"HEAT" Speed - cfm				Second Stage "COOL" Speed - cfm			
	Low	¹ Med-Low	Med-Hi	High	Low	Med-Low	Med-Hi	¹ High
+	890	1035	1150	1300	660	880	1110	1345
¹ NORM	810	940	1045	1180	600	800	1000	1215
—	730	845	940	1060	540	720	900	1095
"ADJUST" Switch Positions					First Stage "COOL" Speed - cfm			
					Low	Med-Low	Med-Hi	¹ High
	+					470	630	765
¹ NORM					440	565	700	835
—					395	510	630	750

¹ Factory default DIP switch setting.

NOTES - The effect of static pressure is included in air volumes shown.

First stage COOL (two-stage air conditioning units only) is approximately **70%** of the same second stage COOL speed position.Continuous Fan Only speed is approximately **38%** of the same second stage COOL speed position - minimum 350 cfm.

Lennox Harmony III™ Zoning System Applications - Minimum blower speed is 350 cfm.

BLOWER DATA**ML180UH070V36B BLOWER PERFORMANCE (less filter)****BOTTOM RETURN AIR****0 through 0.8 in. w.g. (Heating) and 0 through 1.0 in. w.g. (Cooling) External Static Pressure Range**

"ADJUST" Switch Positions	Speed Switch Positions							
	"HEAT" Speed - cfm				Second Stage "COOL" Speed - cfm			
	Low	¹ Med-Low	Med-Hi	High	Low	Med-Low	Med-Hi	¹ High
+	875	970	1075	1225	640	820	1020	1290
¹ NORM	800	890	975	1100	600	755	935	1170
—	725	810	885	995	540	685	835	1050
"ADJUST" Switch Positions					First Stage "COOL" Speed - cfm			
					Low	Med-Low	Med-Hi	¹ High
	+					440	570	675
¹ NORM					400	530	620	770
—					370	480	570	695

¹ Factory default DIP switch setting.

NOTES - The effect of static pressure is included in air volumes shown.

First stage COOL (two-stage air conditioning units only) is approximately **70%** of the same second stage COOL speed position.Continuous Fan Only speed is approximately **38%** of the same second stage COOL speed position - minimum 350 cfm.

Lennox Harmony III™ Zoning System Applications - Minimum blower speed is 350 cfm.

BLOWER DATA**ML180UH070V48B BLOWER PERFORMANCE (less filter)****BOTTOM RETURN AIR****0 through 0.8 in. w.g. (Heating) and 0 through 1.0 in. w.g. (Cooling) External Static Pressure Range**

"ADJUST" Switch Positions	Speed Switch Positions							
	"HEAT" Speed - cfm				Second Stage "COOL" Speed - cfm			
	Low	¹ Med-Low	Med-Hi	High	Low	Med-Low	Med-Hi	¹ High
+	1410	1550	1750	1930	1045	1375	1640	1850
¹ NORM	1285	1410	1615	1770	940	1250	1500	1700
—	1155	1270	1445	1620	850	1115	1365	1540
"ADJUST" Switch Positions					First Stage "COOL" Speed - cfm			
					Low	Med-Low	Med-Hi	¹ High
	+					615	870	1065
¹ NORM					525	780	960	1130
—					430	685	870	990

¹ Factory default DIP switch setting.

NOTES - The effect of static pressure is included in air volumes shown.

First stage COOL (two-stage air conditioning units only) is approximately **70%** of the same second stage COOL speed position.Continuous Fan Only speed is approximately **38%** of the same second stage COOL speed position - minimum 400 cfm.

Lennox Harmony III™ Zoning System Applications - Minimum blower speed is 400 cfm.

BLOWER DATA**ML180UH090V48B BLOWER PERFORMANCE (less filter)****BOTTOM RETURN AIR****0 through 0.8 in. w.g. (Heating) and 0 through 1.0 in. w.g. (Cooling) External Static Pressure Range**

"ADJUST" Switch Positions	Speed Switch Positions							
	"HEAT" Speed - cfm				Second Stage "COOL" Speed - cfm			
	Low	¹ Med-Low	Med-Hi	High	Low	Med-Low	Med-Hi	¹ High
+	1315	1445	1575	1775	1070	1300	1550	1740
¹ NORM	1195	1315	1430	1615	1000	1210	1410	1600
—	1075	1180	1285	1450	880	1115	1295	1465
"ADJUST" Switch Positions					First Stage "COOL" Speed - cfm			
					Low	Med-Low	Med-Hi	¹ High
	+					750	910	1050
¹ NORM					730	875	990	1120
—					650	800	940	1010

¹ Factory default DIP switch setting.

NOTES - The effect of static pressure is included in air volumes shown.

First stage COOL (two-stage air conditioning units only) is approximately **70%** of the same second stage COOL speed position.Continuous Fan Only speed is approximately **38%** of the same second stage COOL speed position - minimum 400 cfm.

Lennox Harmony III™ Zoning System Applications - Minimum blower speed is 400 cfm.

BLOWER DATA

ML180UH110V60C BLOWER PERFORMANCE (less filter)

BOTTOM RETURN AIR, RETURN AIR FROM BOTH SIDES OR RETURN AIR FROM BOTTOM AND ONE SIDE

0 through 0.8 in. w.g. (Heating) and 0 through 1.0 in. w.g. (Cooling) External Static Pressure Range

"ADJUST" Switch Positions	Speed Switch Positions							
	"HEAT" Speed - cfm				Second Stage "COOL" Speed - cfm			
	Low	¹ Med-Low	Med-Hi	High	Low	Med-Low	Med-Hi	¹ High
+	1530	1700	1850	2150	1560	1765	1980	2180
¹ NORM	1400	1560	1730	1960	1425	1620	1800	2000
—	1260	1400	1560	1764	1280	1460	1620	1800
"ADJUST" Switch Positions					First Stage "COOL" Speed - cfm			
					Low	Med-Low	Med-Hi	¹ High
+					1125	1275	1420	1585
¹ NORM					1030	1165	1290	1450
—					930	1050	1160	1305

¹ Factory default DIP switch setting.

NOTES - The effect of static pressure is included in air volumes shown.

First stage COOL (two-stage air conditioning units only) is approximately **70%** of the same second stage COOL speed position.

Continuous Fan Only speed is approximately **38%** of the same second stage COOL speed position - minimum 550 cfm.

Lennox Harmony III™ Zoning System Applications - Minimum blower speed is 550 cfm.