



GAS UNITS KITS & ACCESSORIES

©2021

507985-02
01/2021
Supersedes 507985-01

GAS CHANGEOVER KIT

INSTALLATION INSTRUCTIONS FOR NATURAL TO LP/PROPANE GAS CHANGEOVER KIT (19D59) USED WITH ML180UHV-030 SERIES UNITS

⚠ WARNING

This conversion kit is to be installed by a licensed professional service technician (or equivalent) or other qualified agency in accordance with the manufacturer's instructions, all codes and requirements of the authority having jurisdiction in the USA, and the requirements of the CSA-B149 installation codes in Canada. If the information in these instructions is not followed exactly, a fire or explosion may result causing property damage, personal injury or loss of life. The qualified agency performing this work assumes responsibility for this conversion.

Shipping and Packing List

Package 1 of 1 contains:

- 4 - Main burner orifices (0.028)
- 1 - Gas converter sticker
- 1 - Nameplate conversion sticker
- 1 - Bag assembly containing:
 - 1- Gas valve regulator spring
 - 1- Low gas inlet pressure switch (S145)
 - 1- Gas valve inlet fitting
 - 1- Wiring harness

Application

Use this natural to LP/Propane gas conversion kit to convert ML180UHV units from natural gas to LP/Propane.

Installation

⚠ WARNING

Danger of explosion.
There are circumstances in which odorant used with LP/propane gas can lose its scent. In case of a leak, LP/propane gas will settle close to the floor and may be difficult to smell. An LP/propane leak detector should be installed in all LP applications.

⚠ CAUTION

As with any mechanical equipment, contact with sharp sheet metal edges can result in personal injury. Take care while handling this equipment and wear gloves and protective clothing.

⚠ CAUTION

Gas valve conversion kit **MUST** be installed **BEFORE** the unit is fired using LP/propane gas. Unit damage **WILL OCCUR** if the unit is fired using LP/ propane gas with the original natural gas orifices.

- 1 - Set the thermostat to the lowest setting. If the gas supply line has been connected, shut off the gas supply to the furnace, then disconnect the electrical power.
- 2 - Remove the heating compartment access panel. Turn the automatic gas valve switch to the OFF position. See figure 4.
- 3 - Disconnect the gas supply and the two wires at the gas valve.
- 4 - Remove the four manifold securing screws. Slide the manifold/gas valve assembly out of the burner box. See figure 1.
- 5 - Replace the burner orifices with the provided gas orifices. Torque to approximately 35 in-lbs. Do not use sealant on orifices.
- 6 - Replace the gas valve regulator spring with the provided regulator spring. See figure 5.

⚠ IMPORTANT

DO NOT use pipe dope or any pipe sealant on gas orifice threads.



MANIFOLD GAS VALVE ASSEMBLY

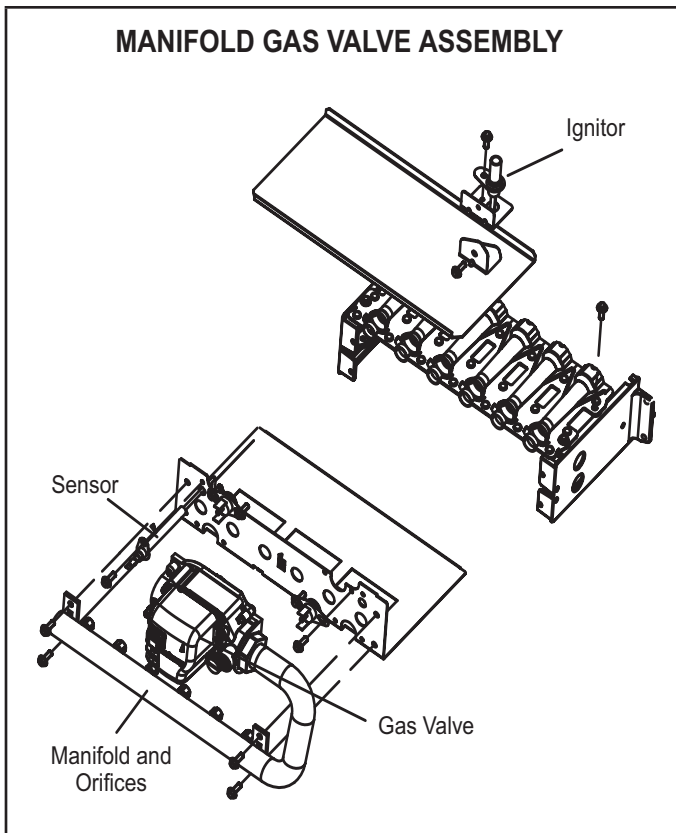

FIGURE 1

- 7 - Re-install the manifold/valve assembly.
 - 8 - Thread provided fitting to gas valve inlet until hand tight. Using properly sized wrench, tighten fitting 2 to 3 full turns being careful to position the side port to allow clearance for the pressure switch and harness. See figure 2 or 3.
- NOTE** - Never use channel lock pliers or a pipe wrench on the brass fitting.
- NOTE** - Some installations may require the pressure switch and fitting assembly to be positioned differently than shown in figure 2 and 3.
- 9 - Thread the gas supply to the fitting until hand tight. A field provided coupling may be needed. See figure 3. Using properly sized wrench to support fitting, tighten supply line into fitting 2 to 3 full turns to achieve leak free joint.
- NOTE** - Do not over tighten. (Maximum 3 full turns past hand tight for ½" NPT per ASME B1.20.1-2013)
- 10 - Thread pressure switch (S145) to fitting 2 to 3 turns past hand tight, then wire as shown in figure 6.
 - 11 - Restore the electrical power to the unit.
 - 12 - Inspect all sides of assembly. Turn on gas supply. **Immediately check the entire fitting surface and assembly joints for gas leaks.**

⚠ CAUTION

Carefully check all piping connection for gas leaks. **DO NOT** use matches, candles, open flames or other means of ignition to check for gas leaks. Use a soap solution or other preferred means.

⚠ IMPORTANT

Some soaps used for leak detection are corrosive to certain metals. Carefully rinse piping thoroughly after leak test has been completed.

- 13 - Affix nameplate conversion sticker next to unit nameplate.
- 14 - Complete the information required on the gas converter sticker: date, name, and address. Affix sticker to the exterior of the unit in a visible area.
- 15 - Follow the steps given in the start-up and adjustment section.

GAS VALVE WITH LOW INLET PRESSURE SWITCH (S145) LOCATION

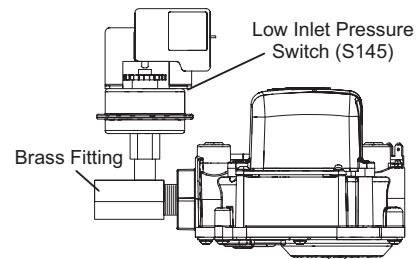

FIGURE 2

GAS VAVE WITH LOW INLET PRESSURE SWITCH (S145) LOCATION

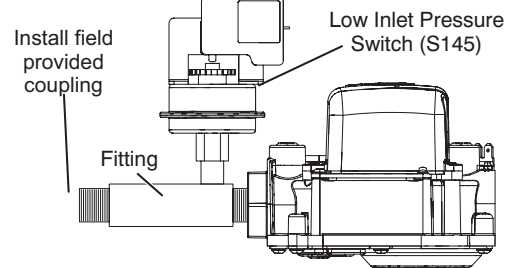
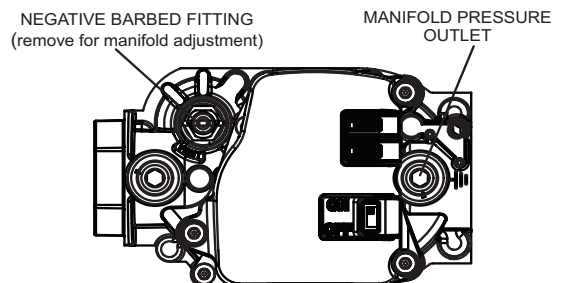

FIGURE 3

GAS VALVE



GAS VALVE SHOWN IN ON POSITION

FIGURE 4

CONVERSION OF GAS VALVE

1. Remove the barbed (if equipped) fitting and pressure regulator adjusting screw.
2. Remove the existing spring.
3. Insert the replacement spring.
4. Install the new plastic pressure regulator adjustment screw so that the top of the screw is flush (level) with the top of the regulator. Turn the pressure regulator adjusting screw clockwise six complete turns. This adjustment provides a preliminary pressure setting of about 10 inches w.c. for the LP /propane regulator.
5. Check the regulator setting either with a manometer or by clocking the gas meter.
6. Re-install the barbed fitting.

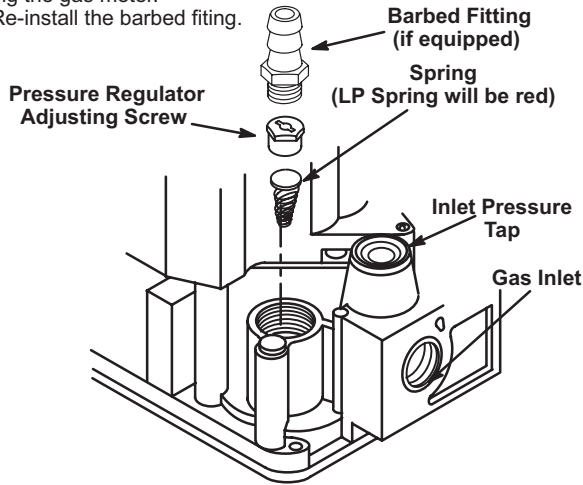

FIGURE 5

Start-Up & Adjustment

BEFORE LIGHTING - Smell all around the appliance area for gas. Be sure to smell next to the floor because LP/ Propane gas is heavier than air and will settle on the floor. Use only your hand to move the gas control switch. Never use tools. If the switch will not move by hand, do not try to repair it. Force or attempted repair may result in a fire or explosion.

A - Placing the Unit into Operation

⚠ IMPORTANT

Follow the lighting instructions provided on the unit. If lighting instructions are not available, refer to the following section.

Units are equipped with a hot surface ignition system. The ignition system automatically lights the burners each time the thermostat calls for heat.

LOW INLET PRESSURE SWITCH (S145) WIRING Point-to-Point Wiring Diagram

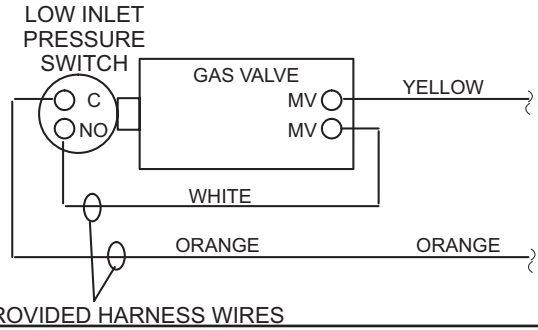

Schematic Diagram

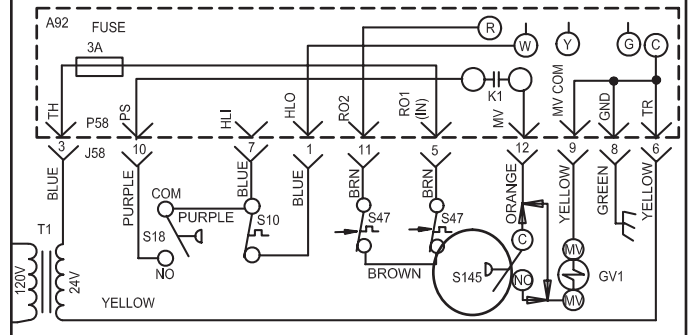

FIGURE 6

- 1 - **STOP!** Read the safety information at the beginning of this section.
- 2 - Set the thermostat to its lowest setting.
- 3 - Turn off all electrical power to the furnace.
- 4 - Do not try to light the burners by hand.
- 5 - Remove the unit access panel.
- 6 - Move gas valve switch to **OFF**. See figure 4.
- 7 - Wait five (5) minutes for any gas to clear out. If you then smell gas, **STOP!** Immediately call your gas supplier from a neighbor's phone. Follow the gas supplier's instructions. If you do not smell gas, go to the next step.
- 8 - Move gas valve switch to **ON**. See figure 4.
- 9 - Replace the unit access panel.
- 10 - Turn on all electrical power to the unit.
- 11 - Set the thermostat to desired setting.
- 12 - If the furnace will not operate, see the section "Turning Gas Off to the Unit" and call your the gas supplier.

Gas Pressure Measurement

A - Gas Pressure Measurement

**TABLE 1
GAS METER CLOCKING CHART**

Capacity	Seconds for One Revolution			
	Natural		LP/Propane	
	1 cu ft Dial	2 cu ft Dial	1 cu ft Dial	2 cu ft Dial
-030	115	230	300	600
-040	80	160	200	400
-070	55	110	136	272
-090	41	82	102	204
-110	33	66	82	164
-135	27	54	68	136
Natural - 1000 btu/cu ft LP/Propane - 2500 btu/cu ft				

Furnace should operate at least 5 minutes before checking gas flow. Determine time in seconds for two revolutions of gas through the meter. (Two revolutions assures a more accurate time.) **Divide by two** and compare to time in table 1 below. If manifold pressure matches table 2 and rate is incorrect, check gas orifices for proper size and restriction. Remove temporary gas meter if installed.

B - Supply Pressure Measurement

When testing supply gas pressure, use the 1/8" N.P.T. supply line tap located on the gas valve to facilitate test gauge connection. Check gas line pressure with unit firing at maximum rate. Low pressure may result in erratic operation or underfire. High pressure can result in permanent damage to gas valve or overfire.

On multiple unit installations, each unit should be checked separately, with and without units operating. Supply pressure must fall within range listed in table 2.

C - Manifold Pressure Measurement

NOTE - To obtain accurate reading, shut off all other gas appliances connected to meter.

- 1 - Connect test gauge to manifold pressure tap (figure 4) on gas valve.
- 2 - Start unit and allow 5 minutes for unit to reach steady state.
- 3 - After allowing unit to stabilize for 5 minutes, record manifold pressure and compare to value given in table 2.
- 4 - If necessary, make adjustments. Figure 4 shows location of adjustment screw.
- 5 - Shut unit off and remove manometer as soon as an accurate reading has been obtained. Take care to replace pressure tap plug.
- 6 - Start unit and perform leak check. Seal leaks if found.

D - Proper Combustion

Furnace should operate minimum 15 minutes with correct manifold pressure and gas flow rate before checking combustion. Take combustion sample beyond the flue outlet. See table 2. **The carbon monoxide reading should not to exceed 100 ppm.**

**TABLE 2
ML180UHV 0-7500 FT.**

Manifold Pressure in. w.g.	Supply Line Pressure in. w.g.		CO ₂ % LP/Propane
	Min	Max	
10.0	11.0	13.0	7.0 - 8.5