

**INSTALLATION INSTRUCTIONS FOR BIPOLAR IONIZER KIT
USED WITH LGM/LCM036-300, LGH/LCH/KG/KC/KH 156-300 UNITS**

⚠ WARNING

Improper installation, adjustment, alteration, service or maintenance can cause property damage, personal injury or loss of life. Installation and service must be performed by a licensed professional installer (or equivalent), service agency or the gas supplier.

Shipping & Packing List

Package 1 of 1 contains the following:

- 1 - Bipolar ionizer assembly
- 1 - Bag assembly containing:
 - 1- Wiring diagram
 - 2- #10-16 x 5/8" sheet metal screws (3 on 092-210)
 - 2- Screw-in wire ties (156-300 only)
 - 1- Wire tie (156-300 only)
 - 3- Edge protectors (156-300 only)
 - 1- Power harness (LGH/LCH/KG/KC/KH156-300 only)

NOTE - Not all components provided in kit are used in each application.

Check packaging for shipping damage. Contact the last carrier immediately if any shipping damage is found.

⚠ CAUTION

As with any mechanical equipment, contact with sharp sheet metal edges can result in personal injury. Take care while handling this equipment and wear gloves and protective clothing.

General

The Bipolar Ionizer integrates with system controls for effective air cleaning. The brush-type ionizer produces both positive and negative ions. Ionization has been shown to effectively reduce harmful pathogens, pollutants and odors by the introduction of these positive and negative ions into the airstream. These ions are dispersed into the occupied space through the duct system proactively reducing airborne contaminants.

Application

The Needlepoint Bipolar Ionizer (NBPI) kit is specifically designed for LGM/LCM036-300 and LGH/LCH/KG/KC/KH 156-300 units. The ionizer is equipped with dry contacts which allow a Building Automation System (BAS) to interface and indicate ionizer functionality.

Note - The BAS will be able to monitor units equipped with M4 Unit Controllers only. Units with an M3 Unit Controller or no controller need to be connected to a separate monitoring system.

The ionizers are also equipped with a green LED which indicates power is on. When the blower is in operation, power is delivered to the ionizers and ions are generated.

See table 1 for unit application.

TABLE 1

Unit	Part No.	
036-074	21U35	622688-01
092-150	21U36	622688-02
156, 180, 210	21U37	622688-03
240	21U38	622688-04
300	21U39	622688-05



Specifications	
Ionizer dimension	3.875" L x 1.500" W x 1.500" H (98mm x 38mm x 38mm)
Lamp assembly dimension	40.75" L x 2" W x 2.75" H (1035mm x 51mm x 60mm)
Triangular sheet metal panel dimension	036-074 - 40.620" L x 1.688" W x 2.688" H (1032mm x 43mm x 68mm) 092-150 - 24.000" L x 0.591" W x 3.717" H (610mm x 15mm x 94mm) 156-300 - 68.812" L x 2.438" W x 0.750" H (1748mm x 62mm x 19mm)
Electrical power supply	24V
Power consumption	<1 Watt
Temperature (outside of duct):	5°F to 158°F (-15°C to 70°C)
Relative humidity	<95%.
Listings: Conforms to ANSI/UL Std. 867. Certified to CSA 22.2 #187	
Specifications subject to change without notice.	

Before Installation

- Turn off power to the rooftop unit.
- Open access to the control box, blower compartment and the filter section.

⚠ WARNING



Electric shock hazard.
Can cause injury or death.
Disconnect all remote power supplies before opening any unit access panels.
Unit may have multiple power supplies.
Do not operate without access panels in place.

Install Ionizer

036-074 Units

- 1- On the back side of the unit, remove one screw securing the horizontal supply air duct cover in place. See figure 1. Retain the screw to secure the back side of the ionizer bracket.
- 2- Install ionizer assembly on the blower deck to the left of the blower housing; secure with two provided screws. See figure 2.

- 3- On the back side of the unit, reinstall the retained screw engaging the back side of the ionizer bracket. See figure 2.

092-150 Units

- 1- Install ionizer assembly on the blower deck to the left of the blower using 3 provided screws. See figure 3.

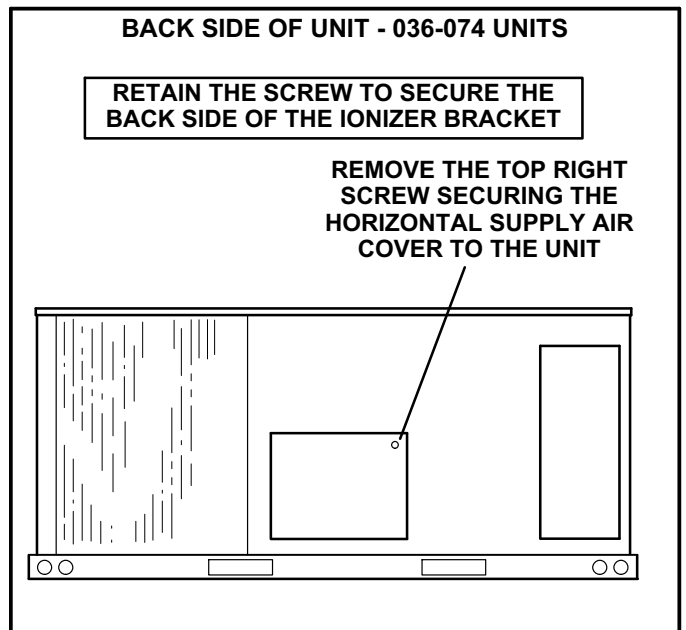

FIGURE 1

INSTALL IONIZER - 036-074

**ON THE BACK SIDE OF THE UNIT,
REINSTALL THE RETAINED SCREW IN
THE SAME LOCATION ON THE DUCT
COVER; BE SURE TO ENGAGE THE
BACK SIDE OF THE IONIZER BRACKET**

**SECURE FRONT OF
BRACKET WITH
TWO SCREWS**

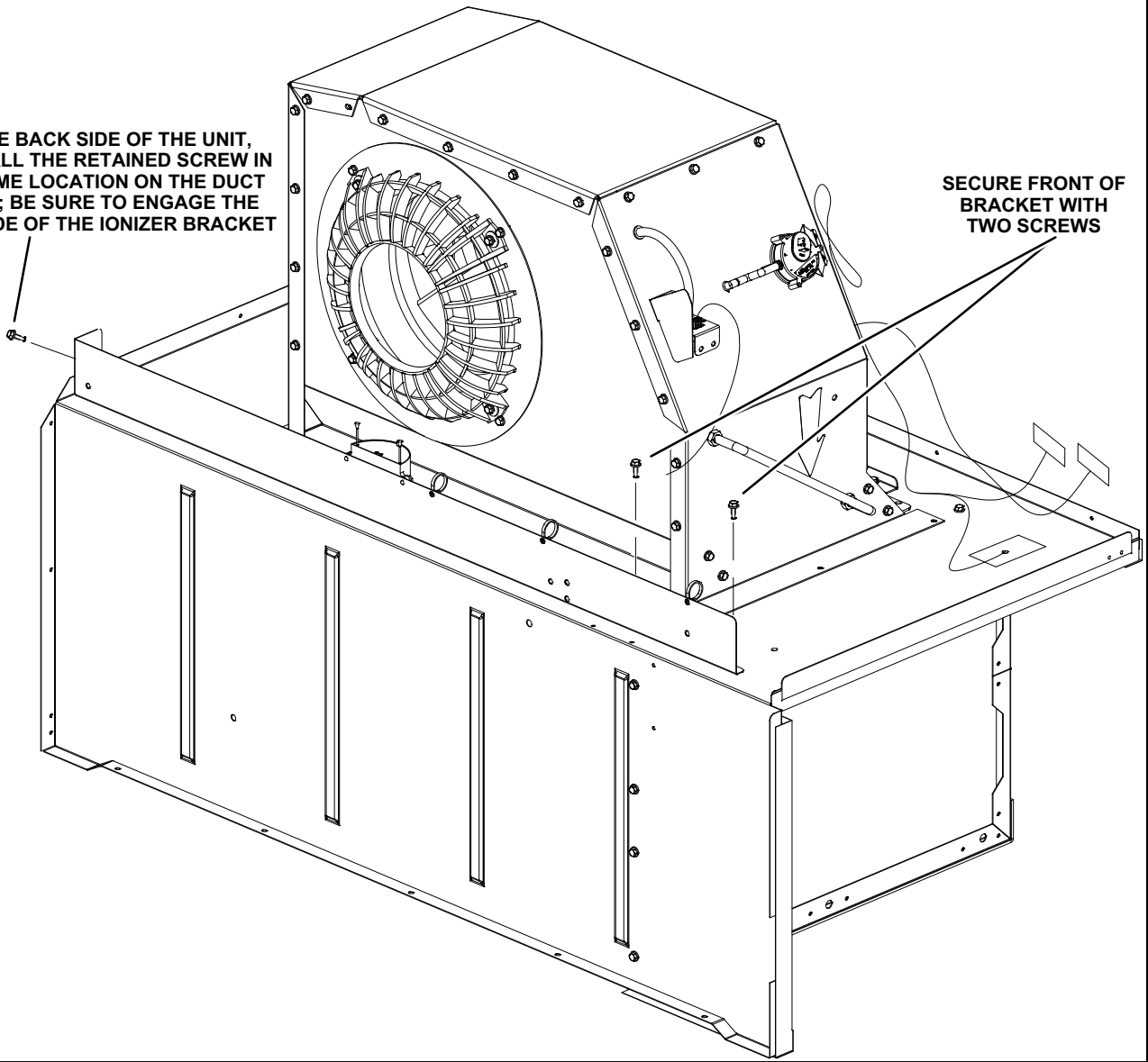

FIGURE 2

INSTALL IONIZER - 092-150

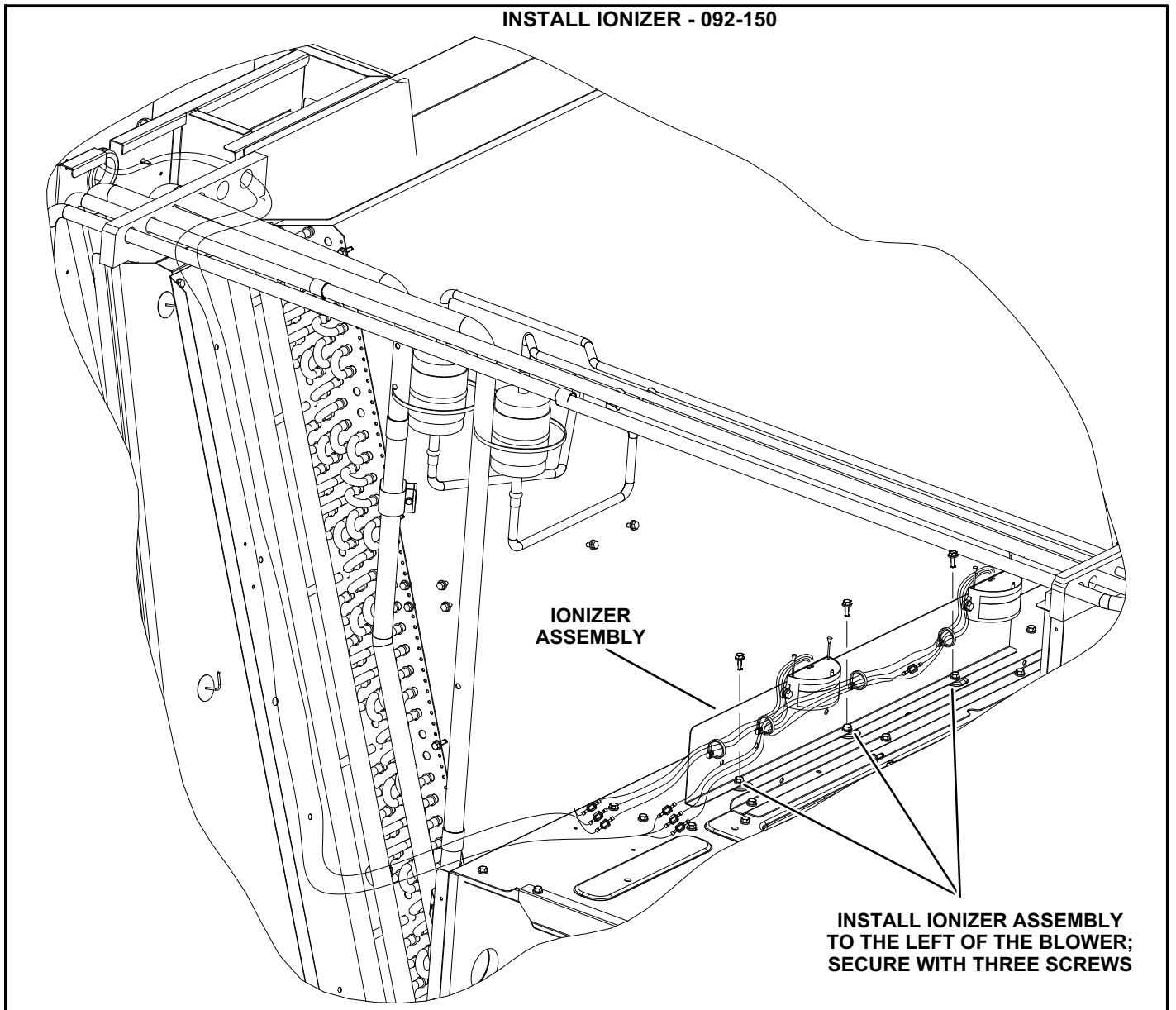

FIGURE 3

156-300 Units

- 1- Open the filter access door and remove the filters and filter puller.
- 2- Remove the screw securing the **bottom** of the upper filter bracket. See detail in figure 4.
- 3- Orient the ionizers toward the indoor coil and slide the ionizer assembly bracket between the upper and lower filter U-channels.
- 4- Using the provided screw, secure a screw-in wire tie where the bottom filter rack screw was removed. See figure 5.
- 5- Install provided edge protectors. See figure 4 for location.
- 6- Remove the screw securing the **top** of the upper filter bracket. See detail in figure 4.
- 7- Using the provided screw, secure a screw-in wire tie where the top filter rack screw was removed. See figure 5.
- 8- Unbundle ionizer wires and route through wire ties.

INSTALL IONIZER - 156-300

**20 TON SHOWN
(5 IONIZERS)**

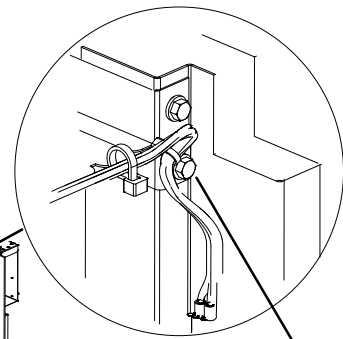

**REMOVE THE SCREW
SECURING THE TOP
OF THE UPPER FILTER
RACK BRACKET**

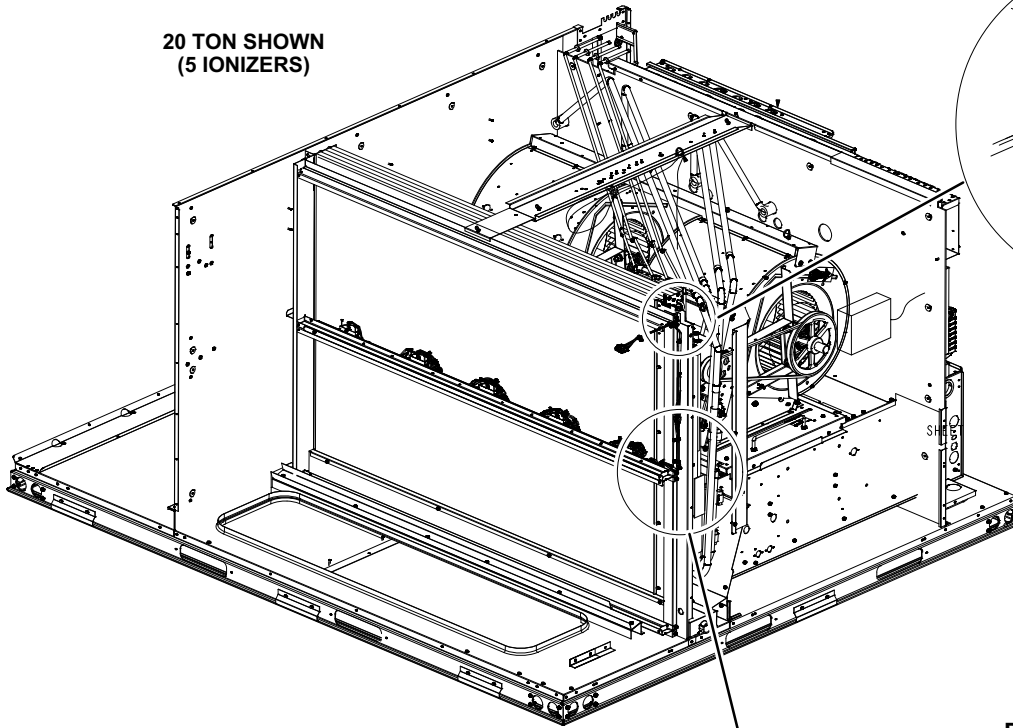

**ONE EDGE
PROTECTOR ON
IONIZER BRACKET**

**EVAPORATOR
COIL**

**TWO EDGE
PROTECTORS ON
FILTER RACK**

**REMOVE THE
SCREW SECURING
THE BOTTOM
OF THE UPPER FILTER
RACK BRACKET**

**IONIZER
BRACKET**

**UPPER FILTER
BRACKET
U-CHANNEL**

**SLIDE IONIZER BRACKET
BETWEEN UPPER AND LOWER
FILTER BRACKET U-CHANNELS**

**LOWER FILTER
BRACKET
U-CHANNEL**

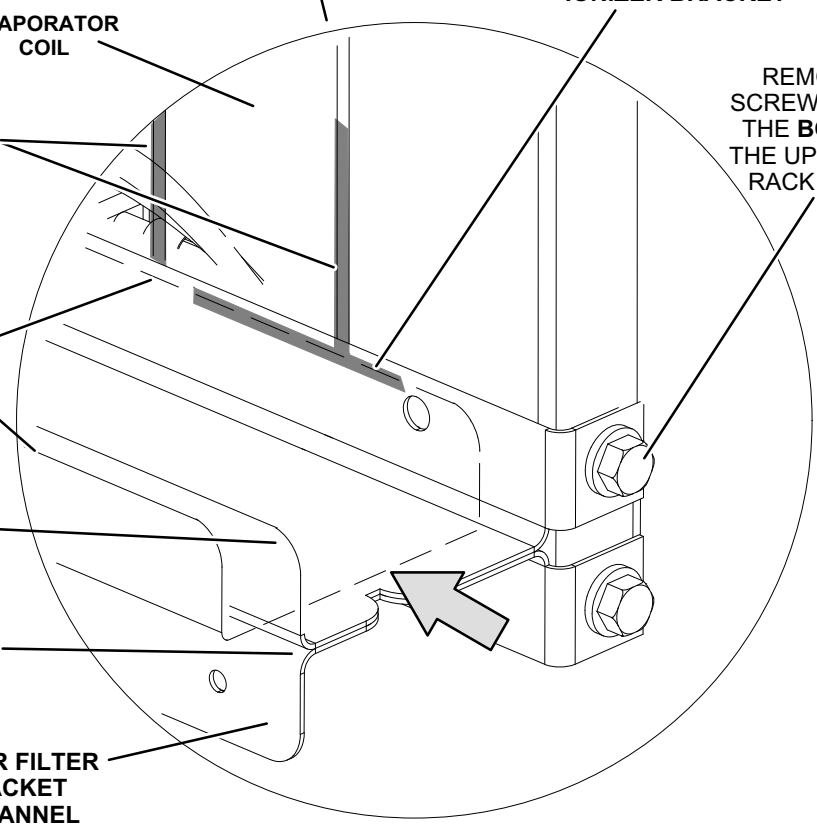

FIGURE 4

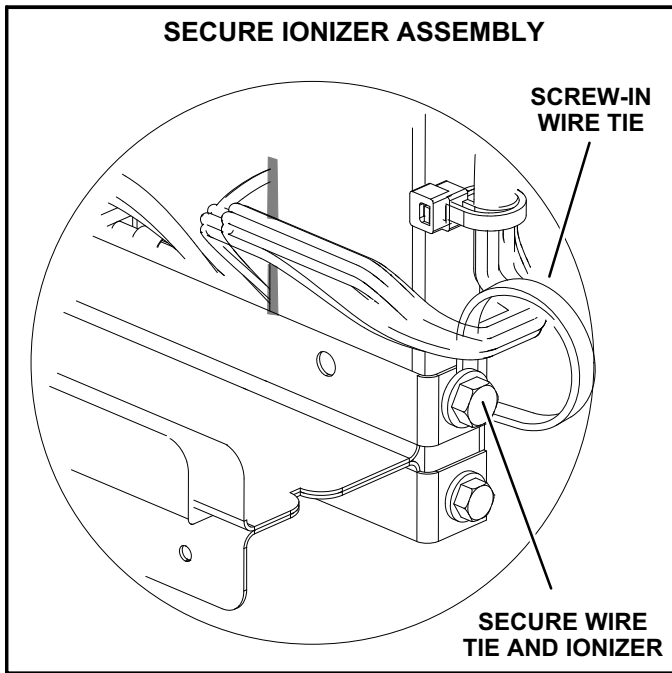

FIGURE 5

Wiring Units With M4 Unit Controller

- 1- Make wiring connections in the as shown in:
 Figure 6 - LGM/LCM036-074 Units
 Figure 7 - LGM/LCM092-150
 Figure 8 - LGM/LCM156-300

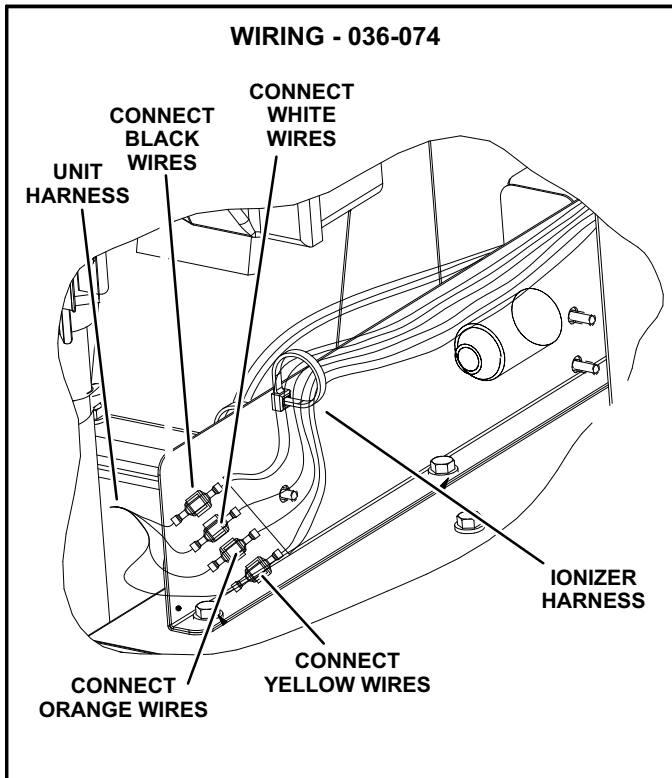

FIGURE 6

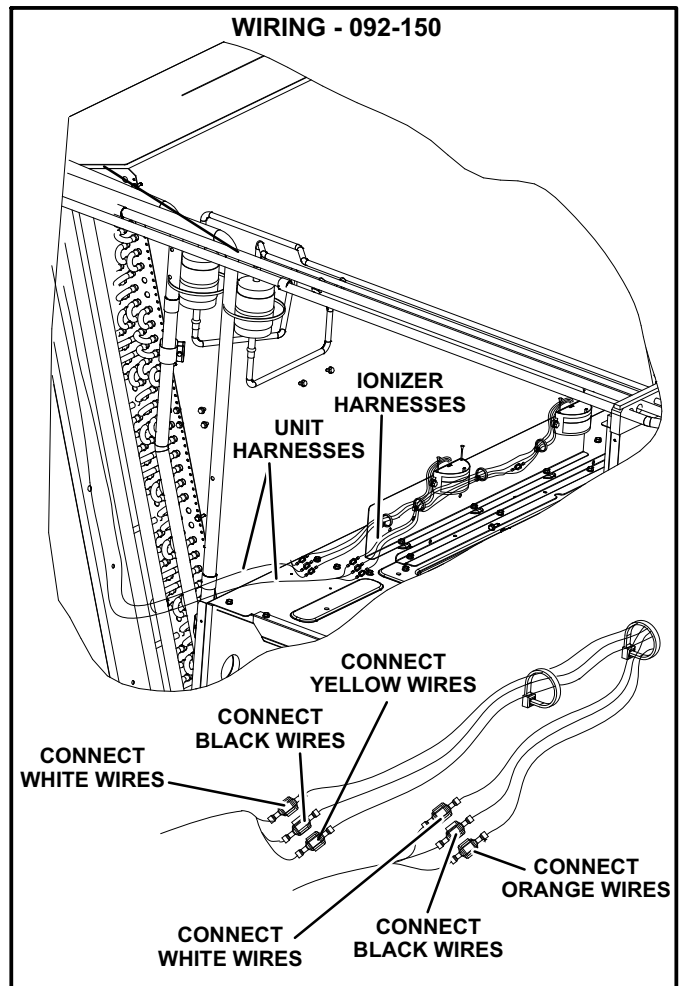
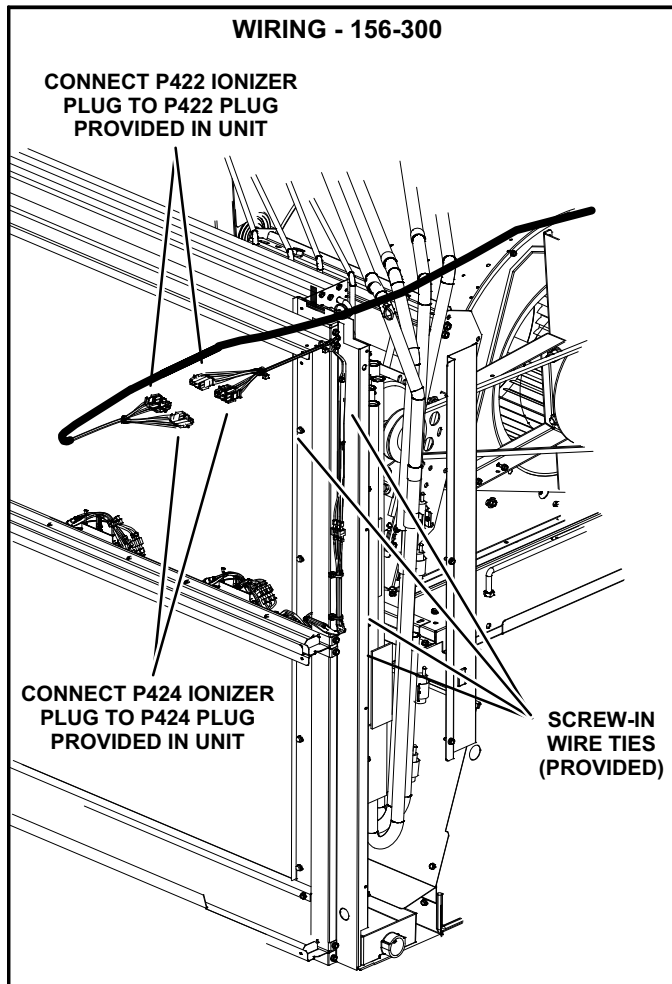

FIGURE 7

Configure M4 For Ionizer

- 1- Use the following mobile service app menu to configure the Unit Controller.
 SETUP > INSTALL > RTU INFORMATION > CONFIGURATION ID2
- 2- Set position 6 to to the appropriate setting to enable the ionizer:
 2=Bipolar Ionizer Installed
 3=Both UV Lamp and Ionizer Installed



Wiring Units With M3 Unit Controller - LGH/LCH156-300S

- 1- Locate the kit harness and cut the wires near the 3-pin plug. Discard plug.
- 2- Route the cut wire ends to the control area and the 2-pin plug to the filter section. See figure 9. Secure with provided wire ties.
- 3- Strip and connect the cut wires to P298 terminals D01 and C on the M3 Unit Controller. See figure 10.
- 4- Connect the 2-pin P422 plug (routed to the filter section) to the ionizer P422. See figure 11.
- 5- Apply power to unit. Use the M3 to navigate through the following menu which enables the ionizer.
 DATA > RTU OPTION > EDIT PARAMETER > ENTER
 DATA ID 186 > OPTION 3
- 6- To monitor ionizer operation, connect orange and yellow BAS ionizer wires to field-provided monitoring system if available. If the BAS signal is not used, bundle wires and secure together.

Wiring Units Without Unit Controller

- 1- Locate the kit harness and cut the wires near the 3-pin plug. Discard plug.
- 2- Route the cut wire ends to the control area and the 2-pin plug to the filter section. See figure 9. Secure with provided wire ties.
- 3- Strip and connect the cut wires to TB1 terminals G and C. See figure 12.
- 4- Connect the 2-pin P422 plug (routed to the filter section) to the ionizer P422 plug. See figure 11.
- 5- To monitor ionizer operation, connect orange and yellow BAS ionizer wires to field-provided monitoring system if available. If the BAS signal is not used, bundle wires and secure together.

ROUTE KIT HARNESS - LGH/LCH/KG/KC/KH 156-300S

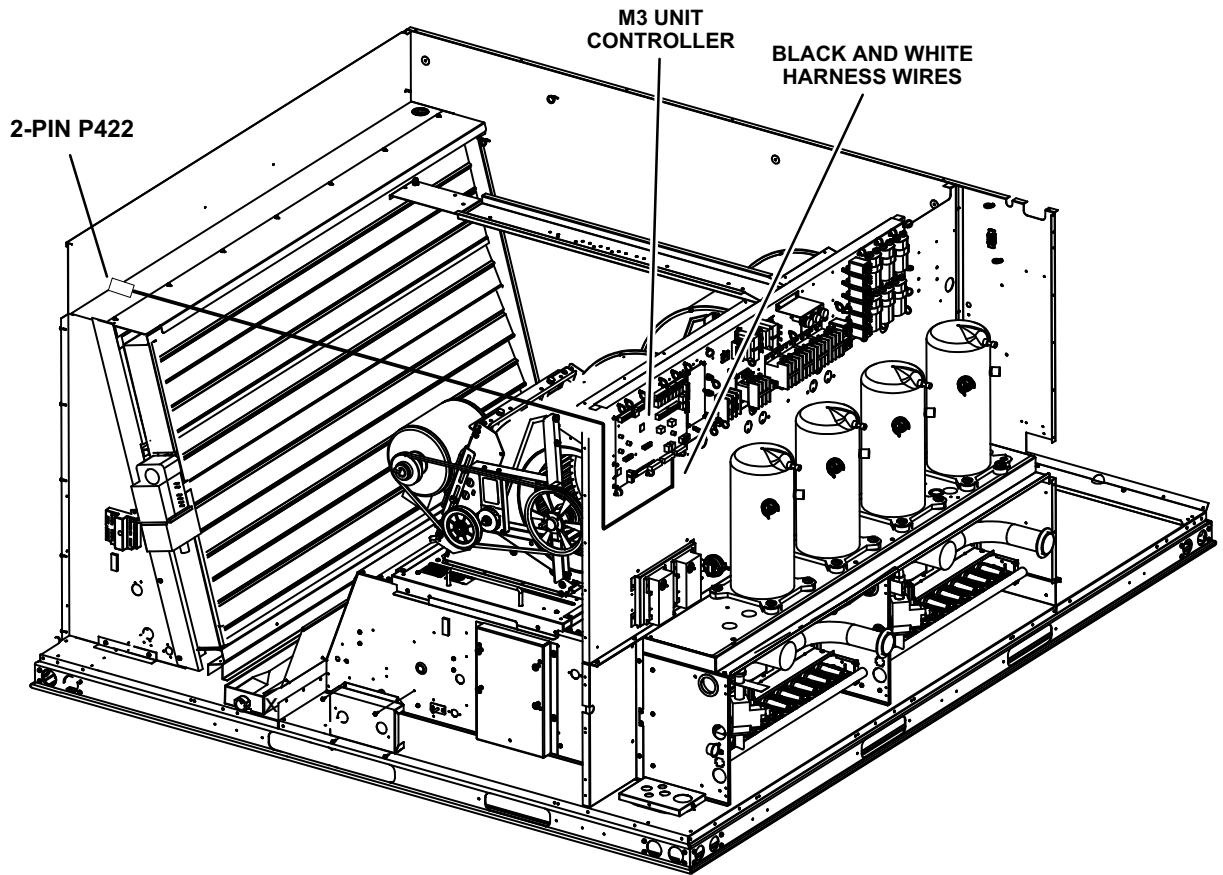

FIGURE 9

HARNESS WIRES TO M3 CONTROLLER - LGH/LCH

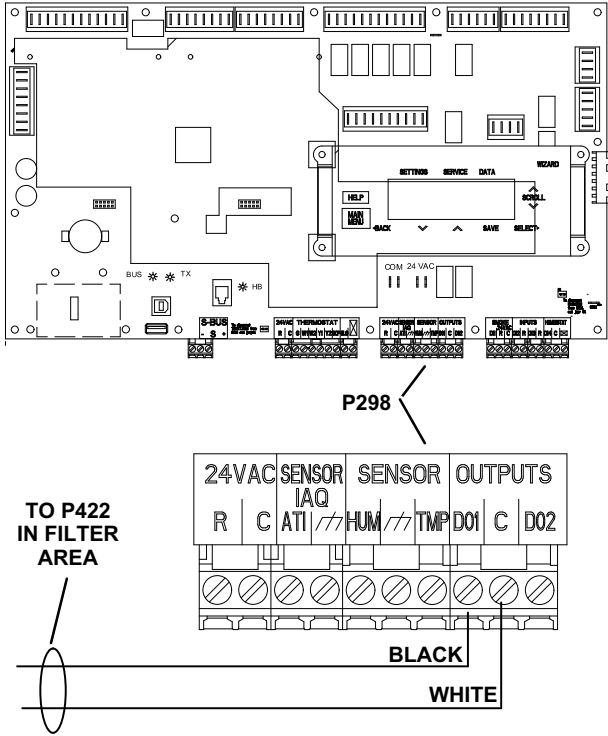

FIGURE 10

CONNECT PLUGS - LGH/LCH/KG/KC/KH156-300

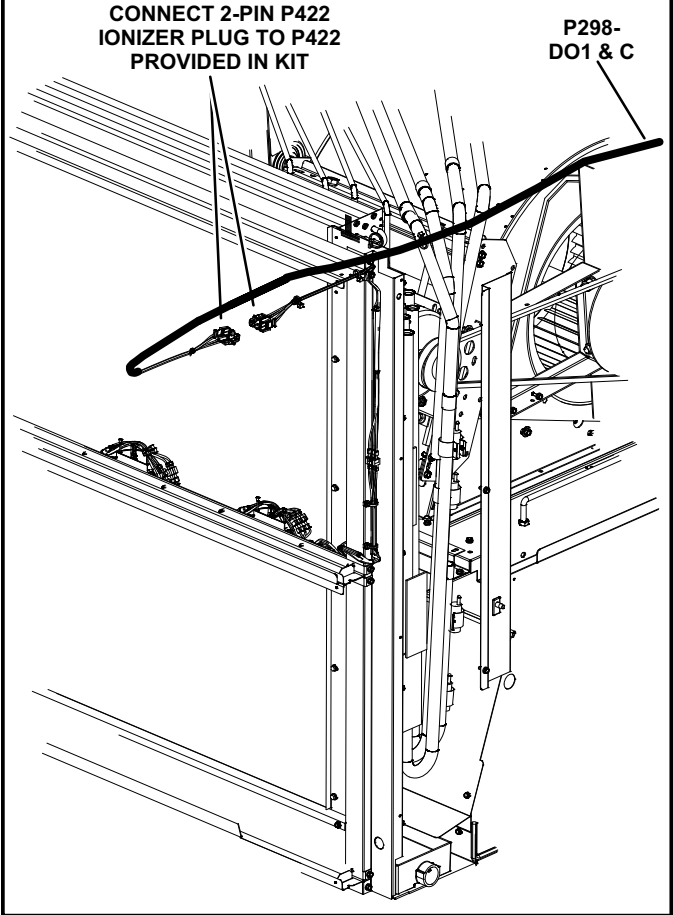

FIGURE 11

TO P422 IN
FILTER SECTION

WIRE KIT HARNESS - KG/KC/KH 156-300S

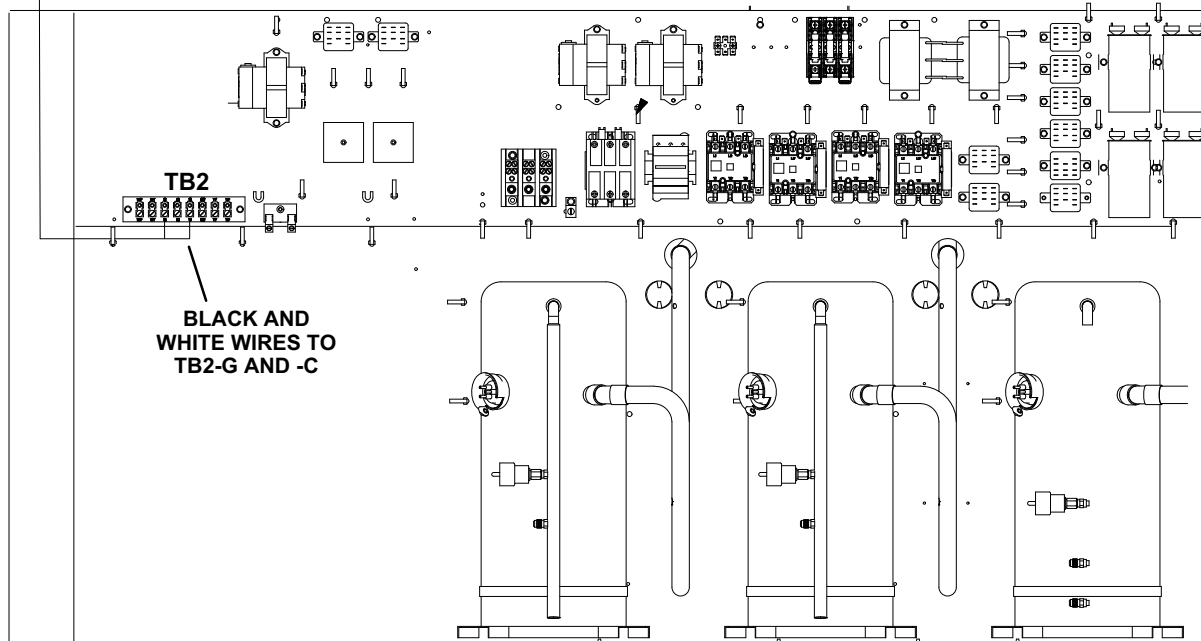

FIGURE 12

Maintenance

⚠ WARNING

Improper installation, adjustment, alteration, service or maintenance can cause property damage, personal injury or loss of life. Installation and service must be performed by a licensed professional installer (or equivalent), service agency or the gas supplier.

The ionizer was designed for low maintenance. The device should be checked semi-annually to confirm the brushes are clean for maximum output. If the carbon fiber brushes are dirty, to clean the device as follows:

- 1- Disconnect power.

- 2- Remove any accumulated dust on bristles of the brushes with either compressed air or a toothbrush.
- 3- Reconnect power.

Troubleshooting

If the unit is not working, check the following:

- 1- The supply fan is running and that the green LED light illuminates.
- 2- Check the power input connections to the ionization unit. Verify all connections are correct and tightened. Reconnect any loose wires as necessary.
- 3- Test dry contact wiring with multimeter set to continuity mode.