

INSTALLATION INSTRUCTIONS

⚠ WARNING

Improper installation, adjustment, alteration, service or maintenance can cause property damage, personal injury or loss of life. Installation and service must be performed by a licensed professional HVAC installer or equivalent, service agency, or the gas supplier

⚠ CAUTION

As with any mechanical equipment, contact with sharp sheet metal edges can result in personal injury. Take care while handling this equipment and wear gloves and protective clothing.

Table of Contents

Dimensions	Page 2
Parts Arrangements	Page 4
Shipping and Packing List	Page 5
General	Page 5
Unit Support	Page 6
Duct Connection	Page 7
Rigging Unit For Lifting	Page 7
Condensate Drains	Page 7
Gas Piping	Page 8
Pressure Test Gas Piping	Page 8
High Altitude Derate	Page 9
Download Mobile Service App	Page 9
Electrical Connections - Power Supply	Page 10

- LGM/LCM156U** (13 Ton)
- LGM/LCM180U** (15 Ton)
- LGM/LCM210U** (17.5 Ton)
- LGM/LCM240U** (20 Ton)
- LGM/LCM300U** (25 Ton)

ROOFTOP PACKAGED UNITS
508117-01
2/2021

Electrical Connections - Control Wiring	Page 10
Blower Operation and Adjustments	Page 12
Cooling Start-Up	Page 19
Temperature Thermistor Sensors	Page 24
Gas Heat Start-Up	Page 28
Heating Operation and Adjustments	Page 29
Electric Heat Start-Up	Page 29
Variable Air Volume Start-Up	Page 30
Multi-Stage Air Volume Start-Up	Page 32
Multi-Stage Air Volume Operation	Page 34
Hot Gas Reheat Start-Up and Operation	Page 35
Service	Page 39
Unit Controller Parameter Settings	Page 44

RETAIN THESE INSTRUCTIONS FOR FUTURE REFERENCE

Attention!

Use this QR code to download the mobile service app. Follow the prompts to pair the app with the unit control system and configure the unit. Refer to the "Download Mobile App" section in this manual and the Setup Guide provided with this unit. The QR code is also available in the unit control area.



The app can be downloaded from the appropriate iOS or Android store. Look for the following icon.



LGM/LCM156U, 180U Unit Dimensions - Inches (mm) - Gas Heat Section Shown

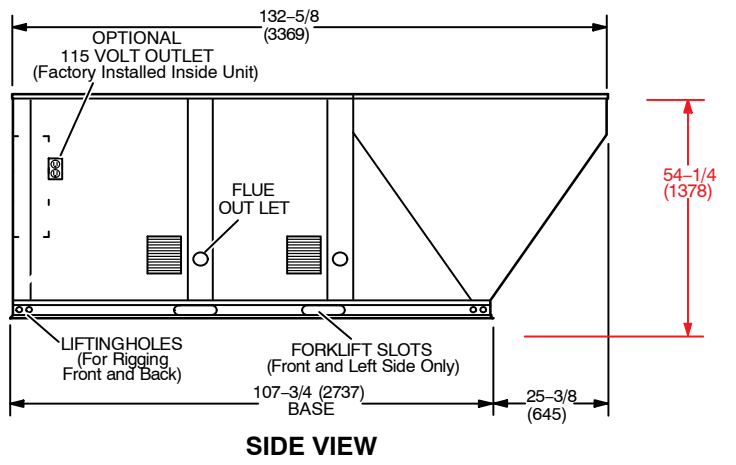
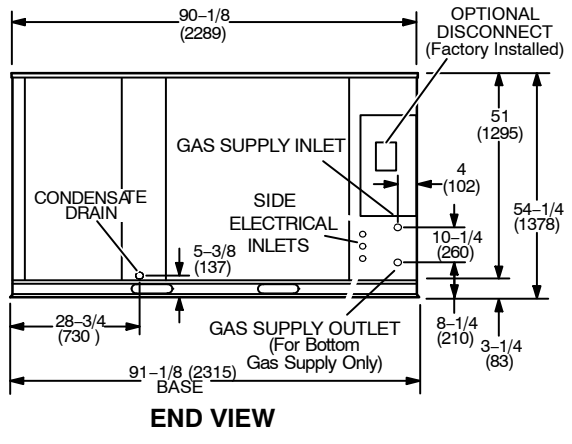
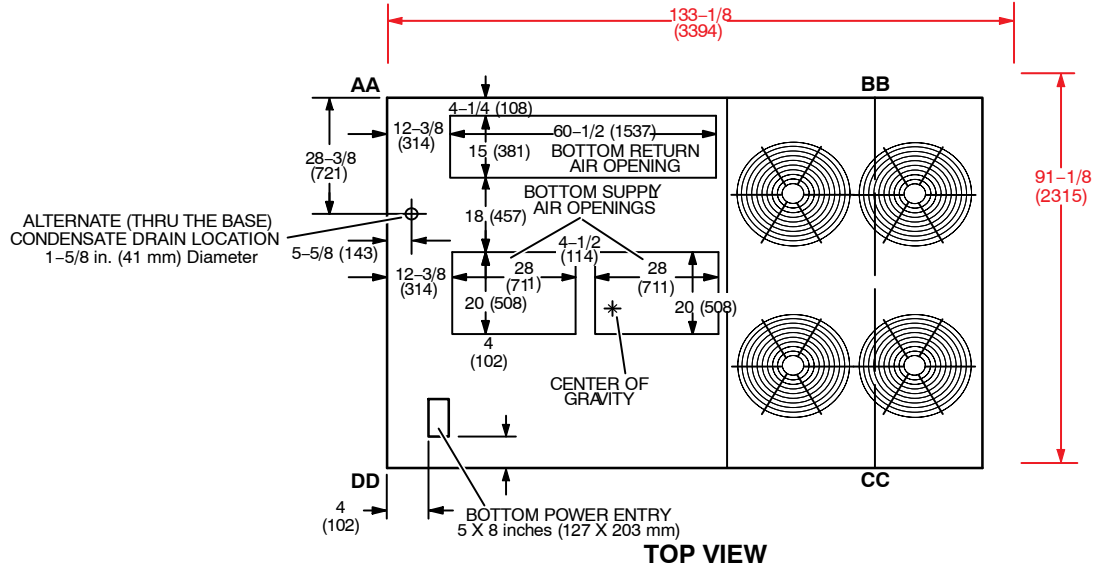

LGM/LCM 210U, 240U & 300U Unit Dimensions - Inches (mm)-Gas Heat Section Shown

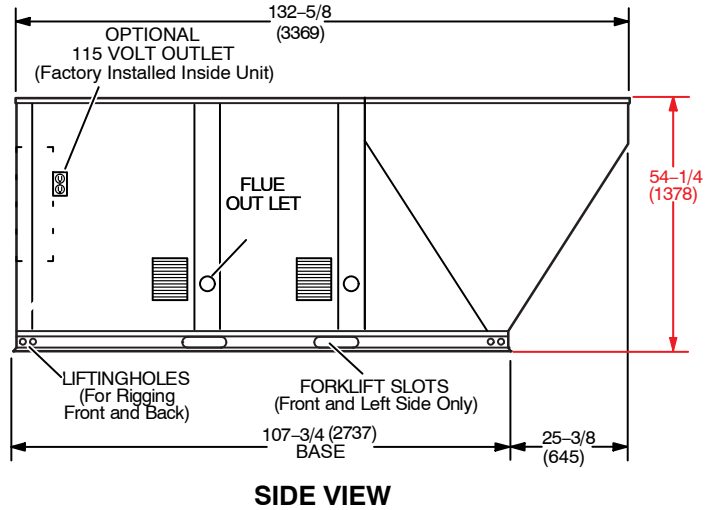
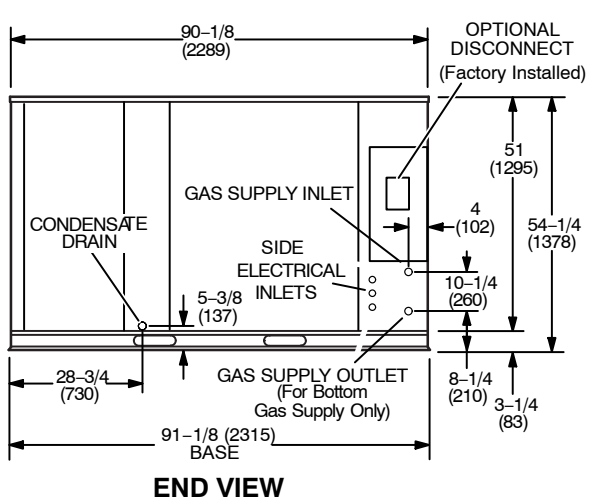
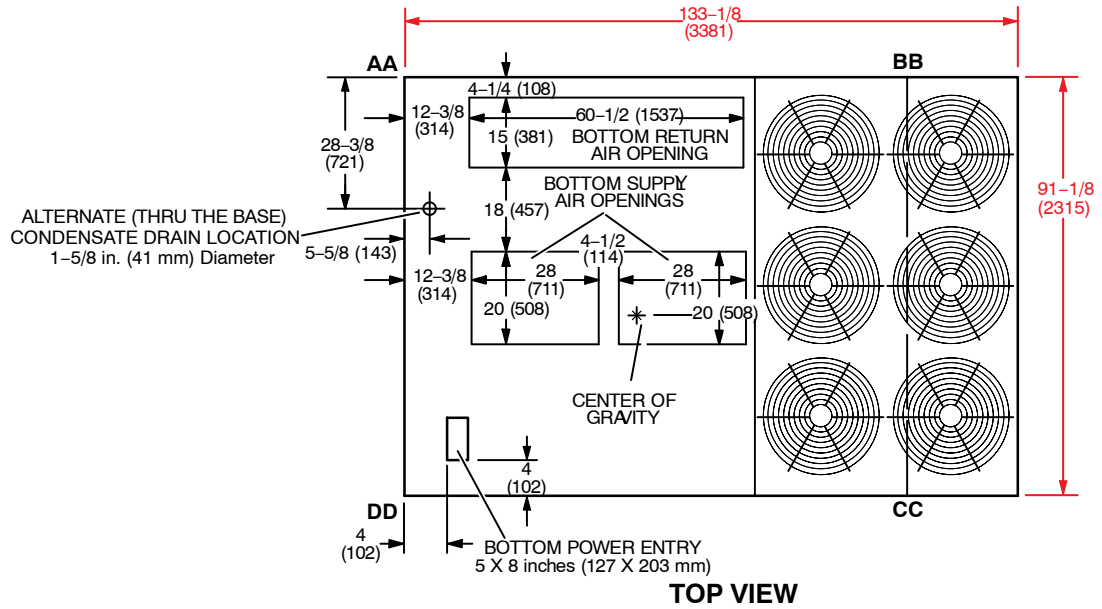

LGM156U, 180U, 210U, 240U, 300U PARTS ARRANGEMENT

210U, 240U, 300U Shown

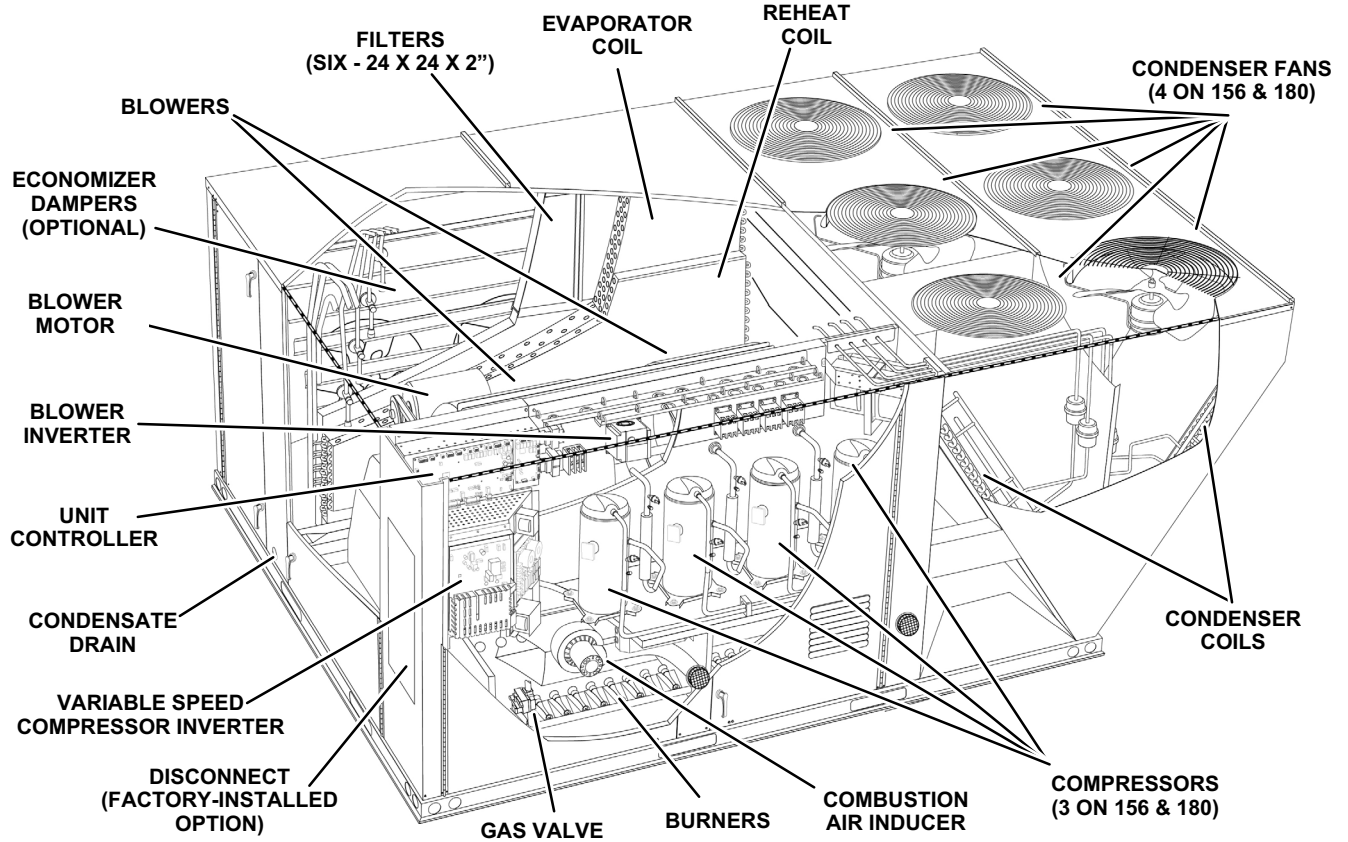

LCM156U, 180U, 210U, 240U, 300U PARTS ARRANGEMENT

210U, 240U, 300U Shown

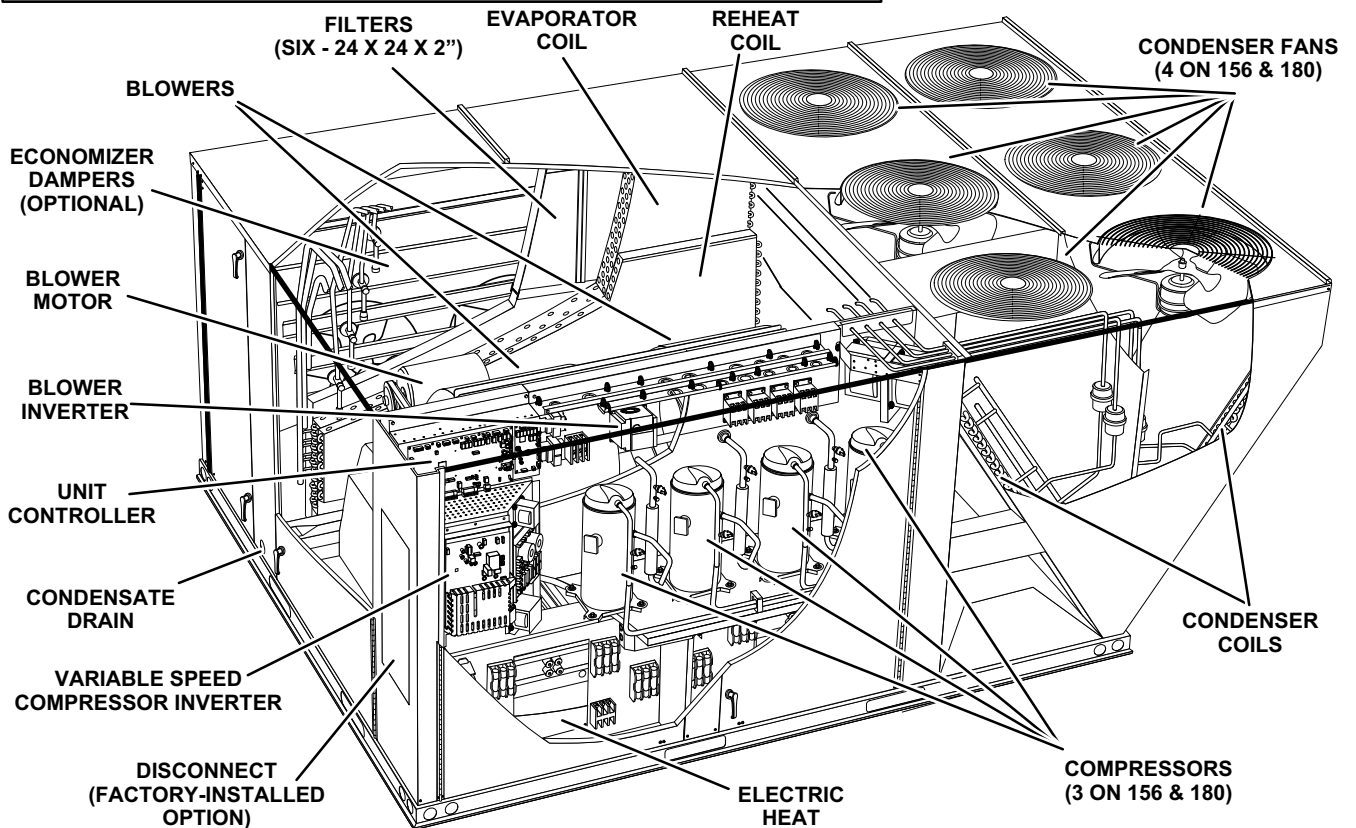

Shipping and Packing List

Package 1 of 1 contains:

1- Assembled unit

Check unit for shipping damage. Receiving party should contact last carrier immediately if shipping damage is found.

General

These instructions are intended as a general guide and do not supersede local codes in any way. Authorities having jurisdiction should be consulted before installation.

The LGM156U gas/electric packaged rooftop unit is available in 260,000 & 360,000 Btuh heating input. The LGM180U, 210U, 240U, & 300U gas/electric packaged rooftop units are available in 260,000, 360,000, or 480,000 Btuh heating inputs.

The LCM cooling packaged rooftop unit is the same basic design as the LGM unit except for the heating section. Optional electric heat is factory- or field-installed in LCM units.

LGM and LCM units have identical refrigerant circuits with respective 13, 15, 17-1/2, 20 and 25 ton cooling capacities. 156U and 180U units contain three compressors; one is variable speed and the other two are fixed speed compressors. 210U, 240U and 300U units contain four compressors; one is variable speed and the other three are fixed speed compressors.

Units come standard with a factory-installed fin/tube condenser coil.

Units are available with an optional hot gas reheat coil which provides a dehumidifying mode of operation. Refer to Reheat Operation section.

Units are available with variable air volume or single-zone variable air volume. Refer to the 9th character of the model number to determine type of blower:

- V - Variable Air Volume
- M - Single-Zone Variable Air Volume

Units use R410A, an ozone-friendly HFC refrigerant. Refer to the Cooling Start-Up section for precautions when installing unit.

⚠ WARNING

Electric shock hazard and danger of explosion. Can cause injury, death or product or property damage. Turn off gas and electrical power to unit before performing any maintenance or servicing operations on the unit. Follow lighting instructions attached to unit when putting unit back into operation and after service or maintenance.

Requirements

See figure 1 for unit clearances.

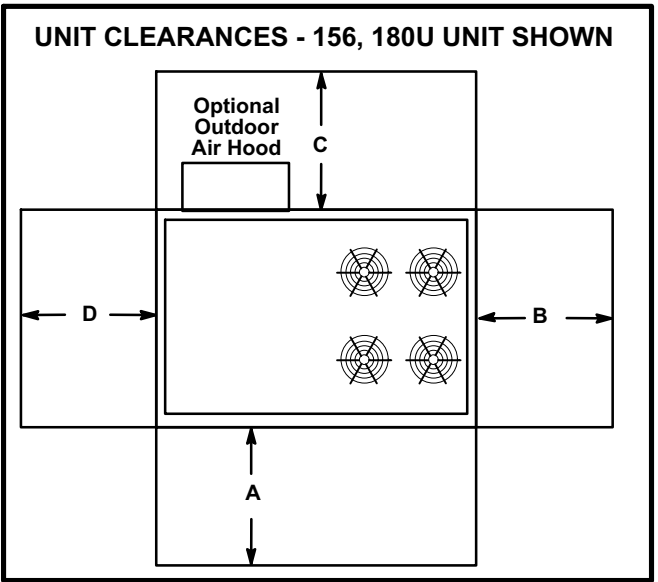

FIGURE 1

¹ Unit Clearance	A in.(mm)	B in.(mm)	C in.(mm)	D in.(mm)	Top Clearance
Service Clearance	60 (1524)	36 (914)	36 (914)	66 (1676)	Unob- structed
Clearance to Combustibles	36 (914)	1 (25)	1 (25)	1 (25)	Unob- structed
Minimum Operation Clearance	36 (914)	36 (914)	36 (914)	41 (1041)	Unob- structed

Note - Entire perimeter of unit base requires support when elevated above mounting surface.

- ¹ **Service Clearance** - Required for removal of serviceable parts.
- Clearance to Combustibles** - Required clearance to combustible material (gas units).
- Minimum Operation Clearance** - Required clearance for proper unit operation.

⚠ NOTICE

Roof Damage!

This system contains both refrigerant and oil. Some rubber roofing material may absorb oil, causing the rubber to swell. Bubbles in the rubber roofing material can cause leaks. Protect the roof surface to avoid exposure to refrigerant and oil during service and installation. Failure to follow this notice could result in damage to roof surface.

Use of this unit as a construction heater or air conditioner is not recommended during any phase of construction. Very low return air temperatures, harmful vapors and operation of the unit with clogged or misplaced filters will damage the unit.

If this unit has been used for heating or cooling of buildings or structures under construction, the following conditions must be met or the warranty will be void:

- The vent hood must be installed per these installation instructions.
- A room thermostat must control the unit. The use of fixed jumpers that will provide continuous heating or cooling is not allowed.
- A pre-filter must be installed at the entry to the return air duct.
- The return air duct must be provided and sealed to the unit.
- Return air temperature range between 55°F (13°C) and 80°F (27°C) must be maintained.
- Air filters must be replaced and pre-filters must be removed upon construction completion.
- The input rate and temperature rise must be set per the unit rating plate.
- The heat exchanger, components, duct system, air filters and evaporator coil must be thoroughly cleaned following final construction clean-up.
- The unit operating conditions (including airflow, cooling operation, ignition, input rate, temperature rise and venting) must be verified according to these installation instructions.

⚠ IMPORTANT

The Clean Air Act of 1990 bans the intentional venting of refrigerant (CFC's and HCFC's) as of July 1, 1992. Approved methods of recovery, recycling or reclaiming must be followed. Fines and/or incarceration may be levied for non-compliance.

Unit Support

In downflow discharge installations, install the unit on a non-combustible surface only. Unit may be installed on combustible surfaces when used in horizontal discharge applications or in downflow discharge applications when installed on an LARMF18/36 roof mounting frame.

NOTE - Securely fasten roof frame to roof per local codes.

⚠ CAUTION

To reduce the likelihood of supply / return air bypass and promote a proper seal with the RTU, duct work / duct drops / diffuser assemblies must be supported independently to the building structure.

A-Downflow Discharge Application

Roof Mounting with LARMF18/36

- 1- The LARMF roof mounting frame must be installed, flashed and sealed in accordance with the instructions provided with the frame.
- 2- The LARMF roof mounting frame should be square and level to 1/16" per linear foot (5mm per linear meter) in any direction.
- 3- Duct must be attached to the roof mounting frame and not to the unit; supply and return plenums must be installed before setting the unit.

Installer's Roof Mounting Frame

Many types of roof frames can be used to install the unit depending upon different roof structures. Items to keep in mind when using the building frame or supports are:

- 1- The base is fully enclosed and insulated, so an enclosed frame is not required.
- 2- The frames or supports must be constructed with non-combustible materials and should be square and level to 1/16" per linear foot (5mm per linear meter) in any direction.
- 3- Frame or supports must be high enough to prevent any form of moisture from entering unit. Recommended minimum frame height is 14" (356mm).
- 4- Duct must be attached to the roof mounting frame and not to the unit. Supply and return plenums must be installed before setting the unit.
- 5- Units require support along all four sides of unit base. Supports must be constructed of steel or suitably treated wood materials.

NOTE-When installing a unit on a combustible surface for downflow discharge applications, an LARMF18/36 roof mounting frame is required.

B-Horizontal Discharge Applications

- 1- Units installed in horizontal airflow applications must use an LARMFH18/24 horizontal roof mounting frame. The supply air duct connects to the horizontal supply air opening on the LARMFH18/24. The return air duct connects to the unit horizontal return air opening. Refer to unit dimensions.
- 2- Specified installation clearances must be maintained when installing units. Refer to figure 1.
- 3- Top of support slab should be approximately 4" (102mm) above the finished grade and located so no run-off water from higher ground can collect around the unit.
- 4- Units require support along all four sides of unit base. Supports must be constructed of steel or suitably treated wood materials.

Duct Connection

All exterior ducts, joints and openings in roof or building walls must be insulated and weather-proofed with flashing and sealing compounds in accordance with applicable codes. Any duct passing through an unconditioned space must be insulated.

CAUTION

In downflow applications, do not drill or punch holes in base of unit. Leaking in roof may occur if unit base is punctured.

Rigging Unit For Lifting

Rig unit for lifting by attaching four cables to holes in unit base rail. See figure 2.

- 1- Detach wooden base protection before rigging.
- 2- Connect rigging to the unit base using both holes in each corner.
- 3- All panels must be in place for rigging.
- 4- Place field-provided H-style pick in place just above top edge of unit. Frame must be of adequate strength and length. (H-style pick prevents damage to unit.)

RIGGING

Unit	*Weight	
	Lbs.	Kg.
LC 156, 180	2400	1089
LC 210	2550	1157
LG 156, 180		
LC 240, 300	2700	1225
LG 210		
LG 240, 300	2850	1293

*Maximum weight with all available factory-installed accessories.

LIFTING POINT SHOULD BE DIRECTLY ABOVE CENTER OF GRAVITY

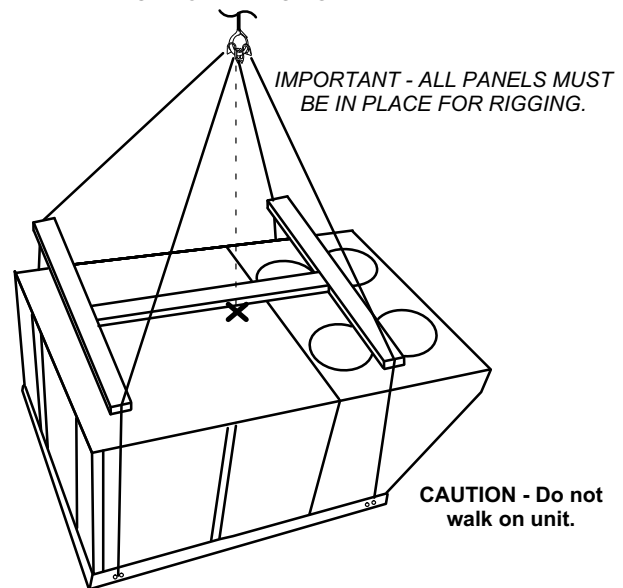

FIGURE 2

Condensate Drains

Remove cap and make drain connection to the 1" N.P.T. drain coupling provided on unit. A trap must be installed between drain connection and an open vent for proper condensate removal. See figure 3. It is sometimes acceptable to drain condensate onto the roof or grade; however, a tee should be fitted to the trap to direct condensate downward. The condensate line must be vented. Check local codes concerning condensate disposal. Refer to pages 2, 3 and 4 for condensate drain location.

Note - The drain pan is made with a glass reinforced engineered plastic capable of withstanding typical joint torque but can be damaged with excessive force. Tighten pipe nipple hand tight and turn an additional quarter turn.

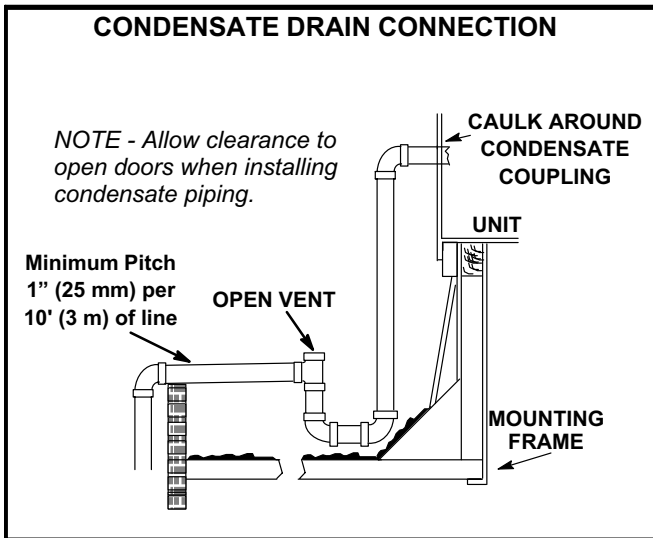

FIGURE 3

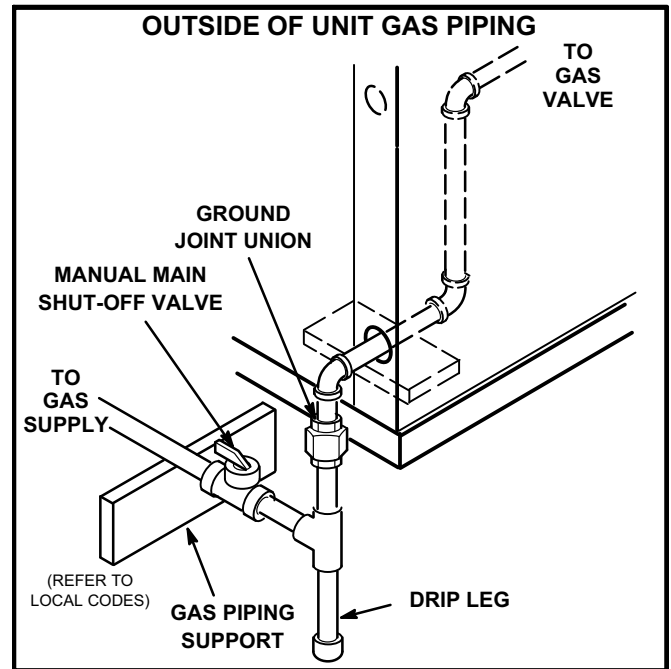

FIGURE 4

Connect Gas Piping

Before connecting piping, check with gas company or authorities having jurisdiction for local code requirements. When installing gas supply piping, length of run from gas meter must be considered in determining pipe size for 0.5" w.c. (.12kPa) maximum pressure drop. Do not use supply pipe smaller than unit gas connection. For natural gas units, operating pressure at the unit gas connection must be a minimum of 4.7" w.c. (1.17kPa) and a maximum of 10.5" (2.60kPa) w.c. For LP/propane gas units, operating pressure at the unit gas connection must be a minimum of 11" w.c. (2.74kPa) and a maximum of 13.5" w.c. (3.36kPa).

When making piping connections a drip leg should be installed on vertical pipe runs to serve as a trap for sediment or condensate. A 1/8" N.P.T. plugged tap is located on gas valve for test gauge connection. Refer to Heating Start-Up section for tap location. Install a ground joint union between the gas control manifold and the main manual shut-off valve. See figure 4 for gas supply piping entering outside the unit. See figure 5 for gas supply entering through bottom of unit.

Compounds used on threaded joints of gas piping shall be resistant to the action of liquified petroleum gases.

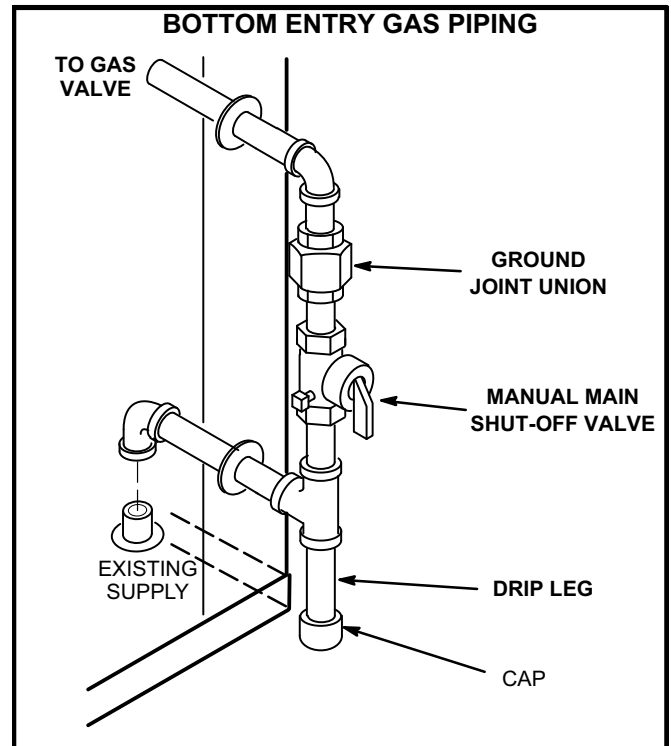

FIGURE 5

Pressure Test Gas Piping

When pressure testing gas lines, the gas valve must be disconnected and isolated. Gas valves can be damaged if subjected to more than 0.5 psig (3.48kPa). See figure 6.

NOTE-Codes may require that manual main shut-off valve and union (furnished by installer) be installed in gas line external to unit. Union must be of the ground joint type.

After all connections have been made, check all piping connections for gas leaks. Also check existing unit gas connections up to the gas valve; loosening may occur during installation. Use a leak detection solution or other preferred means. Do not use matches candles or other sources of ignition to check for gas leaks.

NOTE-In case emergency shut down is required, turn off the main manual shut-off valve and disconnect main power to unit. These devices should be properly labeled by the installer.

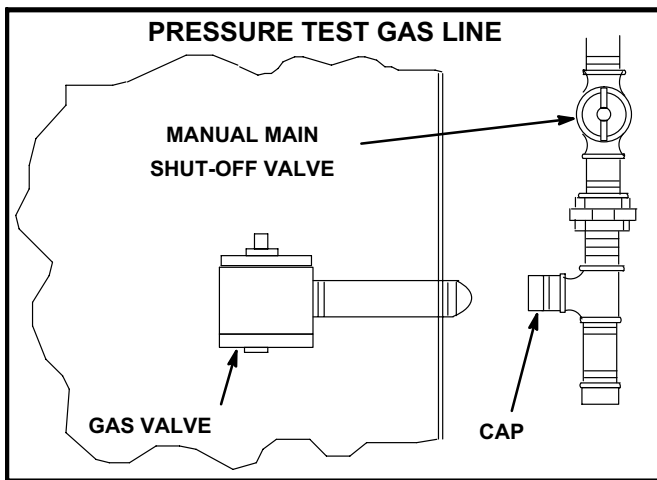

FIGURE 6

CAUTION

Some soaps used for leak detection are corrosive to certain metals. Carefully rinse piping thoroughly after leak test has been completed. Do not use matches, candles, flame or other sources of ignition to check for gas leaks.

WARNING



Danger of explosion. Can cause injury or product or property damage. Do not use matches, candles, flame or other sources of ignition to check for leaks.

High Altitude Derate

Locate the high altitude conversion sticker in the unit literature bag. Fill out the conversion sticker and affix next to the unit nameplate.

Refer to table 1 for high altitude adjustments.

**TABLE 1
HIGH ALTITUDE DERATE**

Altitude Ft.*	Gas Manifold Pressure
2000-4500	See Unit Nameplate
4500 And Above	Derate 2% / 1000 Ft. Above Sea Level

*Units installed at 0-2000 feet do not need to be modified.

NOTE - This is the only permissible derate for these units.

Download Mobile Service App

A-Mobile Device Requirements

- Android hardware requires 2GB RAM and a 2Ghz core processor. Tablets are supported.
- Minimum Android 6.0 (Marshmallow) or higher. Recommend Android 10 and Apple products require iOS version 11 or higher.

B-New Installations

Once the app is downloaded, refer to the Setup Guide provided with this unit to pair the app to the unit control system. Follow the setup wizard prompts to configure the unit. See figure 7 for the app menu overview. **If a mobile device is unavailable or not pairing, refer to the Unit Controller Setup Guide for start-up instructions.**

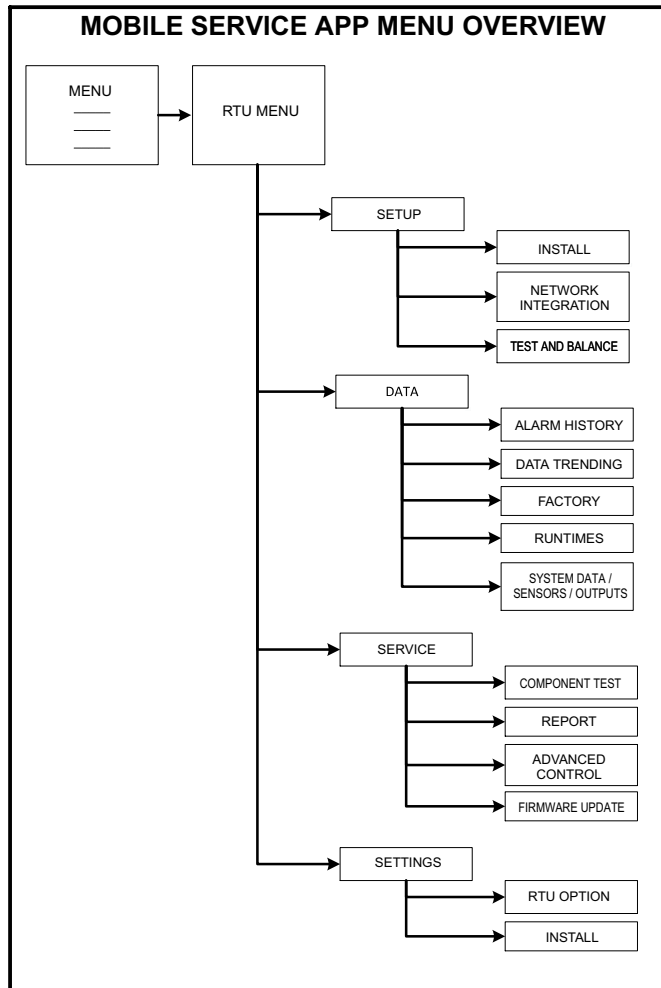

FIGURE 7

Electrical Connections - Power Supply

A-Wiring

Route field wiring in conduit between bottom power entry and disconnect. See figure 8. This does not supersede local codes or authorities having jurisdiction.

Do not apply power or close disconnect switch until installation is complete. Refer to start-up directions. Refer closely to unit wiring diagram.

Refer to unit nameplate for minimum circuit ampacity and maximum fuse size.

- 1- Units are factory-wired for 240/460 volt supply. For 208V supply, remove the insulated terminal cover from the 208V terminal on the control transformer. Move the wire from the transformer 240V terminal to the 208V terminal. Place the insulated terminal cover on the unused 240V terminal.
- 2- Route power through the bottom power entry area and connect to line side of unit disconnect, circuit breaker or terminal block. See unit wiring diagram.
- 3- *Units With Optional 120v GFCI Outlet -*
Route and connect separate 120v wiring to GFCI outlets which do not have factory-installed wiring. Route field wiring in conduit between bottom power entry and GFCI. See figure 8.

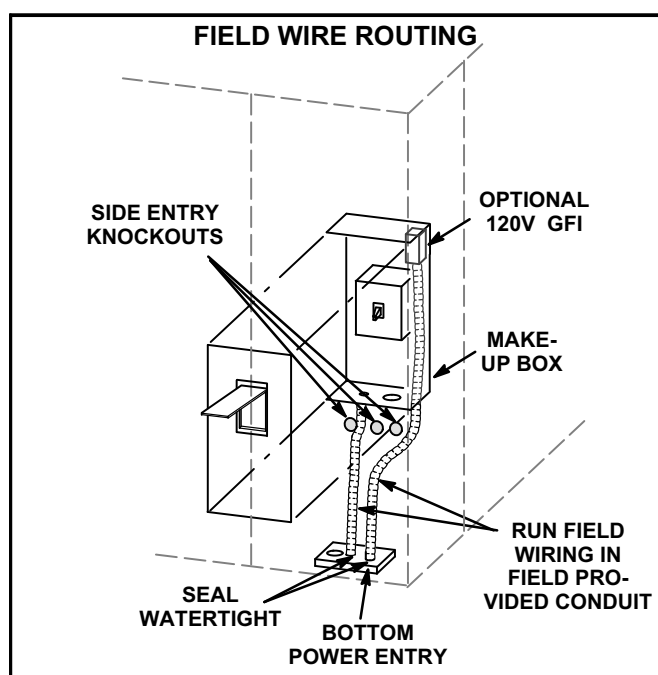

FIGURE 8

B-Unbalanced Three-Phase Voltage

Units equipped with an inverter (VFD) are designed to operate on balanced, three-phase power. Operating units on unbalanced three-phase power will reduce the reliability of all electrical components in the unit. Unbalanced power is a result of the power delivery system supplied by the local utility company.

Factory-installed inverters are sized to drive blower motors with an equivalent current rating using balanced three-phase power. When unbalanced three-phase power is supplied; the installer must replace the existing factory-installed inverter with an inverter that has a higher current rating to allow for the imbalance. Use table 2 to determine the appropriate replacement inverter.

TABLE 2
INVERTER UP-SIZING

Factory-Installed Inverter HP	Replacement Inverter HP
2	5
3	7-1/2
5	10
7.5	15
10	20

Electrical Connections - Control Wiring

A-Thermostat Location

Room thermostat mounts vertically on a standard 2" X 4" handy box or on any non-conductive flat surface.

Locate thermostat approximately 5 feet (1524mm) above the floor in an area with good air circulation at average temperature. Avoid locating the room thermostat where it might be affected by:

- drafts or dead spots behind doors and in corners
- hot or cold air from ducts
- radiant heat from sun or appliances
- concealed pipes and chimneys

B-Wire Routing

Route thermostat cable or wires from subbase through knockout provided in unit. Use 18 AWG wire for all applications using remotely installed electro-mechanical and electronic thermostats.

On hot gas reheat units, route wires from RH sensor or remote switch through knockout provided in unit. For sensor installations, use 22AWG stranded, two twisted pairs, individually shielded, 100% aluminum shield with drain wire and Teflon jacket.

IMPORTANT - Unless field thermostat wires are rated for maximum unit voltage, they must be routed away from line voltage wiring.

C-Wire Connections

The Unit Controller will operate the unit from a thermostat or zone sensor based on the System Mode. The default System Mode is the thermostat mode. Refer to the Unit Controller Setup Guide to change the System Mode. Use the mobile service app menu and select:

SETTINGS > INSTALL.

Note - Unit Controller is capable of up to four stages of cooling in network control mode.

1- Default Thermostat Mode -

The Unit Controller will operate two stages of heating and cooling based on thermostat demands. Install thermostat assembly in accordance with instructions provided with thermostat. See figure 9 for field wiring and refer to wiring diagrams on unit.

IMPORTANT-Terminal connections at the wall plate or subbase must be made securely. Loose control wire connections may result in intermittent operation.

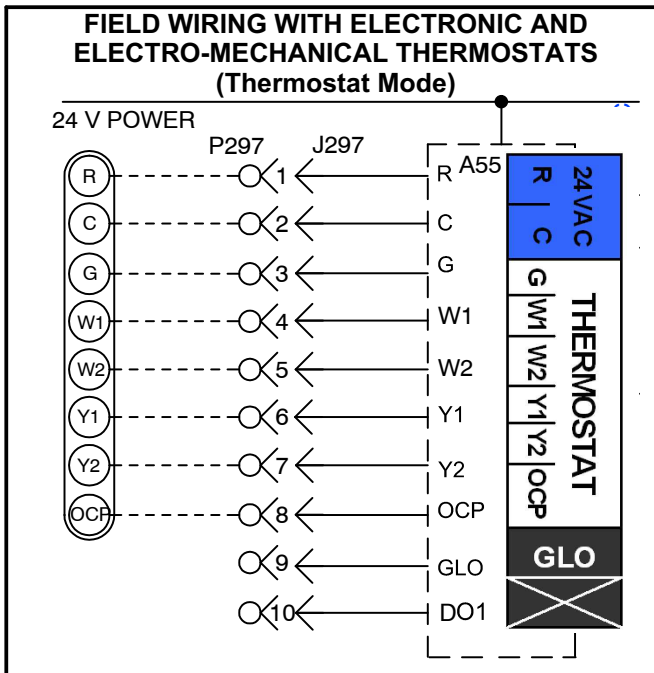

FIGURE 9

2- Zone Sensor Mode -

The Unit Controller will operate heating and cooling based on the Unit Controller internal setpoints and the temperature from the A2 zone sensor. An optional Network Control Panel (NCP) can also be used to provide setpoints. A thermostat or return air sensor can be used as a back-up mode. Make zone sensor wiring connections as shown in figure 10.

Note - Install sensor and make communication wiring connections as shown in literature provided with sensor.

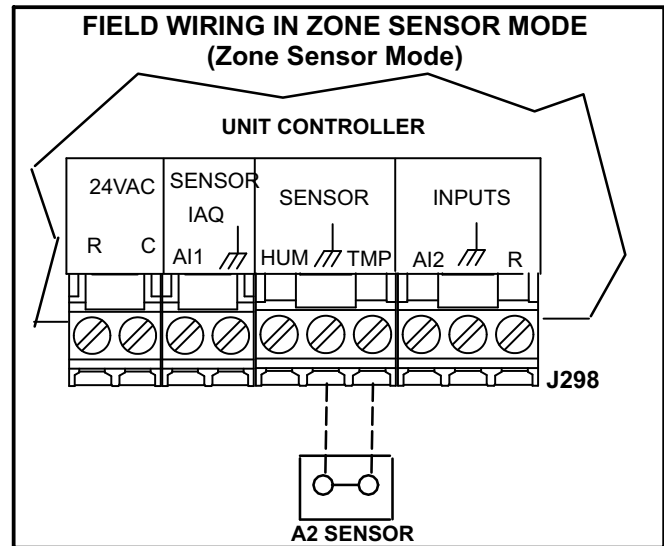

FIGURE 10

D-Hot Gas Reheat Units Only

- 1- Install humidity sensor in accordance with instructions provided with sensor. A DDC input may be used to initiate dehumidification instead of a sensor.
- 2- Make wiring connections as shown in figure 9 for Thermostat Mode and figure 10 for Zone Sensor Mode. In addition, connect either a humidity sensor or a dehumidification input. See figure 11 or 12 for humidity sensor wiring and figure 13 for dehumidification input wiring.

Humidity Sensor Cable Applications:

Wire runs of 50 feet (mm) or less:

Use two separate shielded cables containing 20AWG minimum, twisted pair conductors with overall shield. Belden type 8762 or 88760 (plenum) or equivalent. Connect both cable shield drain wires to TB1-7 as shown in figure 11.

Wire runs of 150 feet (mm) or less:

Use two separate shielded cables containing 18AWG minimum, twisted pair conductors with overall shield. Belden type 8760 or 88760 (plenum) or equivalent. Connect both cable shield drain wires to TB1-7 as shown in figure 11.

Wire runs over 150 feet (mm):

Use a local, isolated 24VAC transformer such as Lennox cat #18M13 (20VA minimum) to supply power to RH sensor as shown in figure 12. Use two shielded cables containing 20AWG minimum, twisted pair conductors with overall shield. Belden type 8762 or 88760 (plenum) or equivalent.

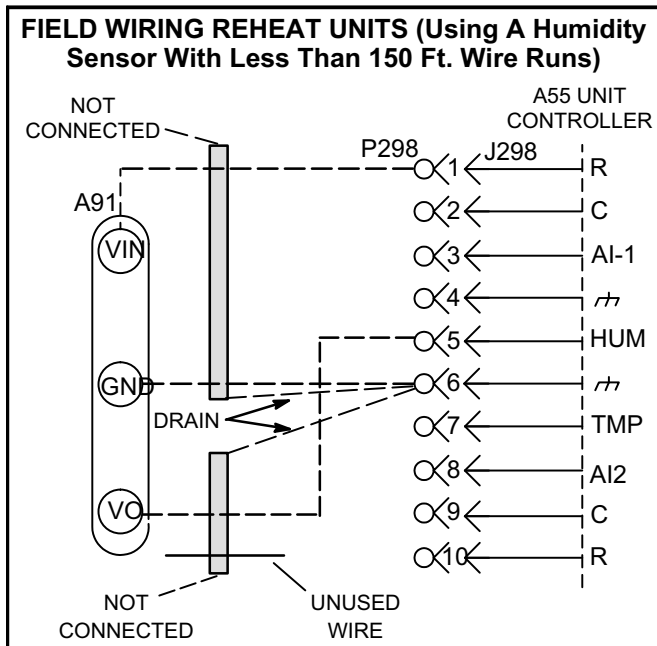

FIGURE 11

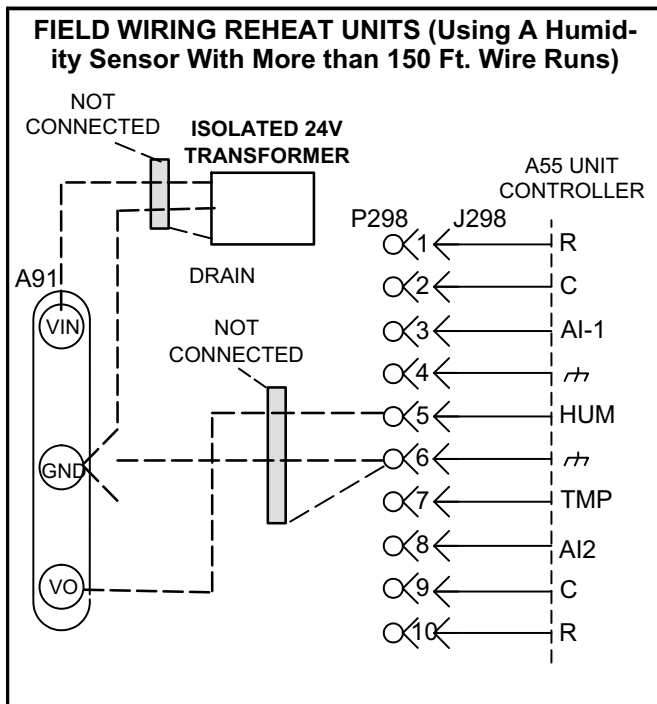

FIGURE 12

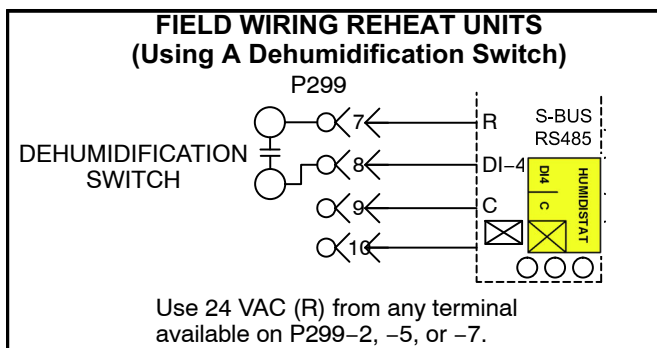

FIGURE 13

Blower Operation and Adjustments

Supply Air Staged Units - The blower rotation will always be correct on units equipped with an inverter. Checking blower rotation is not a valid method of determining voltage phasing for incoming power.

Supply Air Staged Units and Units Equipped With Optional Voltage or Phase Detection - The Unit Controller checks the incoming power during start-up. If the voltage or phase is incorrect, the Unit Controller will display an alarm and the unit will not start.

A-Blower Operation

Refer to the Unit Controller Setup Guide to energize blower. Use this mobile service app menu:

SERVICE > TEST > BLOWER

Instructions provided with the thermostat may also be used to initiate blower only (G) demand. Unit will cycle on thermostat demand. The following steps apply to applications using a typical electro-mechanical thermostat.

- 1- Blower operation is manually set at the thermostat subbase fan switch. With fan switch in **ON** position, blowers will operate continuously.
- 2- With fan switch in **AUTO** position, the blowers will cycle with demand. Blowers and entire unit will be off when system switch is in **OFF** position.

! IMPORTANT

Three Phase Scroll Compressor Voltage Phasing

Three phase scroll compressors must be phased sequentially to ensure correct compressor and blower* rotation and operation. Compressor and blower are wired in phase at the factory. Power wires are color-coded as follows: line 1-red, line 2-yellow, line 3-blue.

1-Observe suction and discharge pressures and blower* rotation on unit start-up.

2-Suction pressure must drop, discharge pressure must rise and blower* rotation must match rotation marking.

If pressure differential is not observed or blower* rotation is not correct:

3-Disconnect all remote electrical power supplies.

4-Reverse any two field-installed wires connected to the line side of S48 disconnect or TB13 terminal strip. Do not reverse wires at blower contactor.

5-Make sure the connections are tight.

Discharge and suction pressures should operate at their normal start-up ranges.

*Supply air inverter blower motors should rotate in the correct direction; verify scroll compressor rotation separately. Contact technical support if the blower is rotating incorrectly.

⚠ WARNING

- 1-Make sure that unit is installed in accordance with the installation instructions and applicable codes.
- 2-Inspect all electrical wiring, both field- and factory-installed, for loose connections. Tighten as required.
- 3-Check to ensure that refrigerant lines do not rub against the cabinet or against other refrigerant lines.
- 4-Check voltage at disconnect switch. Voltage must be within range listed on nameplate. If not, consult power company and have voltage condition corrected before starting unit.
- 5-Make sure filters are new and in place before start-up.

B-Blower Access

- 1- Disconnect jack/plug connector to blower motor. Also disconnect jack/plug connector heating limit switches on gas units.
- 2- Remove screws on either side of blower assembly sliding base. See figure 15.
- 3- Pull base toward outside of unit.

C-Determining Unit CFM

IMPORTANT - Multi-staged supply air units are factory-set to run the blower at full speed when there is a blower (G) demand without a heating or cooling demand. Refer to the field-provided, design specified CFM for all modes of operation. Use the following procedure to adjust motor pulley to deliver the highest CFM called for in the design spec. See Inverter Start-Up section to set blower CFM for all modes once the motor pulley is set.

Variable Air Volume Units - Refer to the Variable Air Volume Start-Up section.

- 1- The following measurements must be made with a dry indoor coil. Run blower (G demand) without a cooling demand. Measure the indoor blower shaft RPM. Air filters must be in place when measurements are taken.
- 2- With all access panels in place, measure static pressure external to unit (from supply to return). Blower performance data is based on static pressure readings taken in locations shown in figure 14.

Note - Static pressure readings can vary if not taken where shown.

- 3- Referring to page 17, use static pressure and RPM readings to determine unit CFM. Use page 18 when installing units with any of the optional accessories listed.
- 4- The blower RPM can be adjusted at the motor pulley. Loosen Allen screw and turn adjustable pulley clockwise to increase CFM. Turn counterclockwise to decrease CFM. See figure 15. Do not exceed minimum and maximum number of pulley turns as shown in table 3.

**TABLE 3
MINIMUM AND MAXIMUM PULLEY ADJUSTMENT**

Belt	Minimum Turns Open	Maximum Turns Open
A Section	No minimum	5
B Section	1*	6

*No minimum number of turns open when B belt is used on pulleys 6" O.D. or larger.

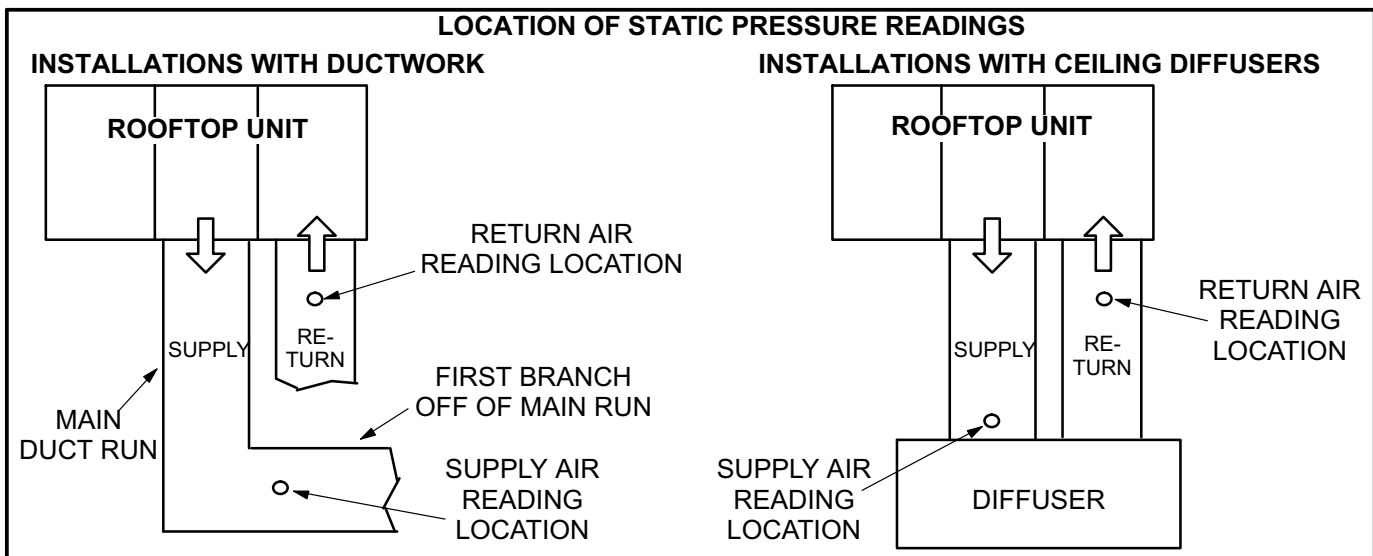

FIGURE 14

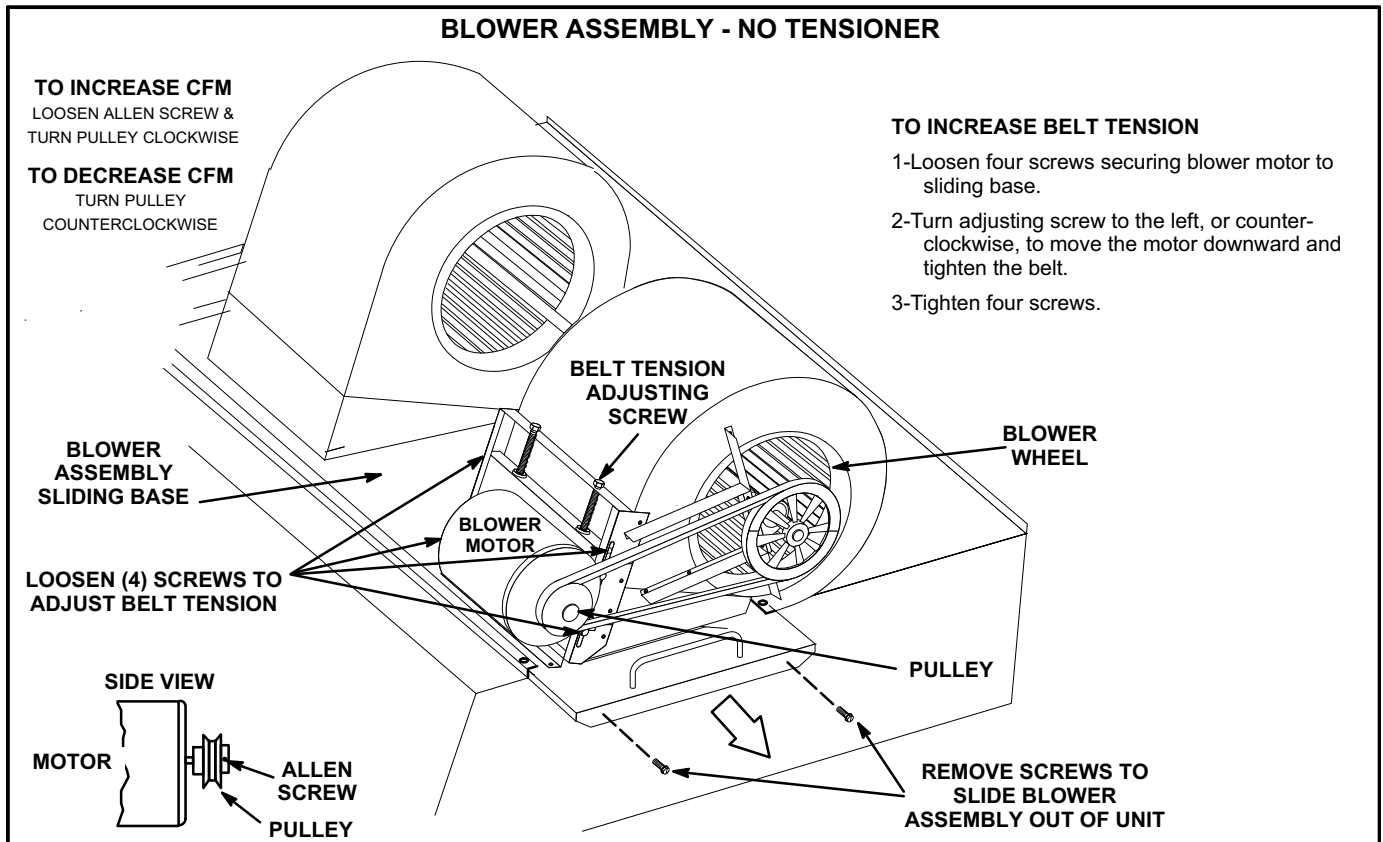

FIGURE 15

D-Blower Belt Adjustment

Maximum life and wear can be obtained from belts only if proper pulley alignment and belt tension are maintained. Tension new belts after a 24-48 hour period of operation. This will allow belt to stretch and seat into pulley grooves. Make sure blower and motor pulley are aligned. See figure 16 for blowers not equipped with a tensioner and figure 17 for units equipped with an optional belt tensioner.

Blowers Without Belt Tensioner

- 1- Loosen four screws securing blower motor to sliding base. See figure 15.
- 2- *To increase belt tension -*
 Turn belt tension adjusting screw to the left, or counterclockwise, to tighten the belt. This increases the distance between the blower motor and the blower housing.
To loosen belt tension -
 Turn the adjusting screw to the right, or clockwise to loosen belt tension.
- 3- Tighten four screws securing blower motor to sliding base once adjustments have been made.

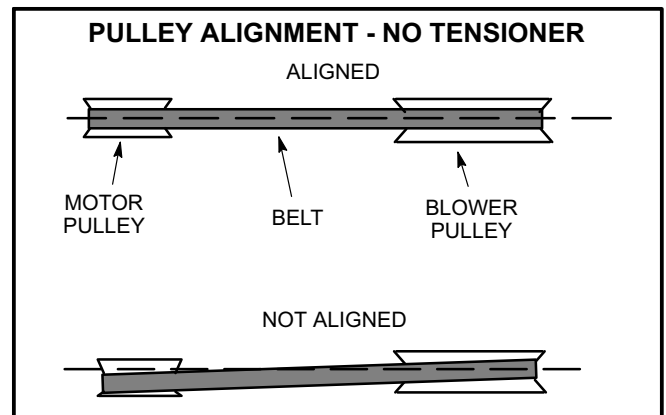

FIGURE 16

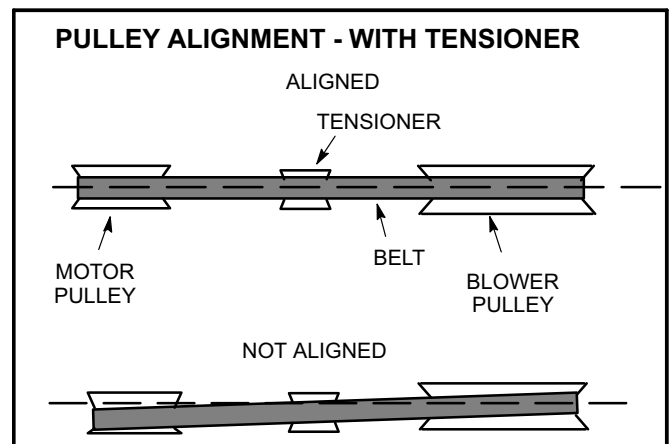

FIGURE 17

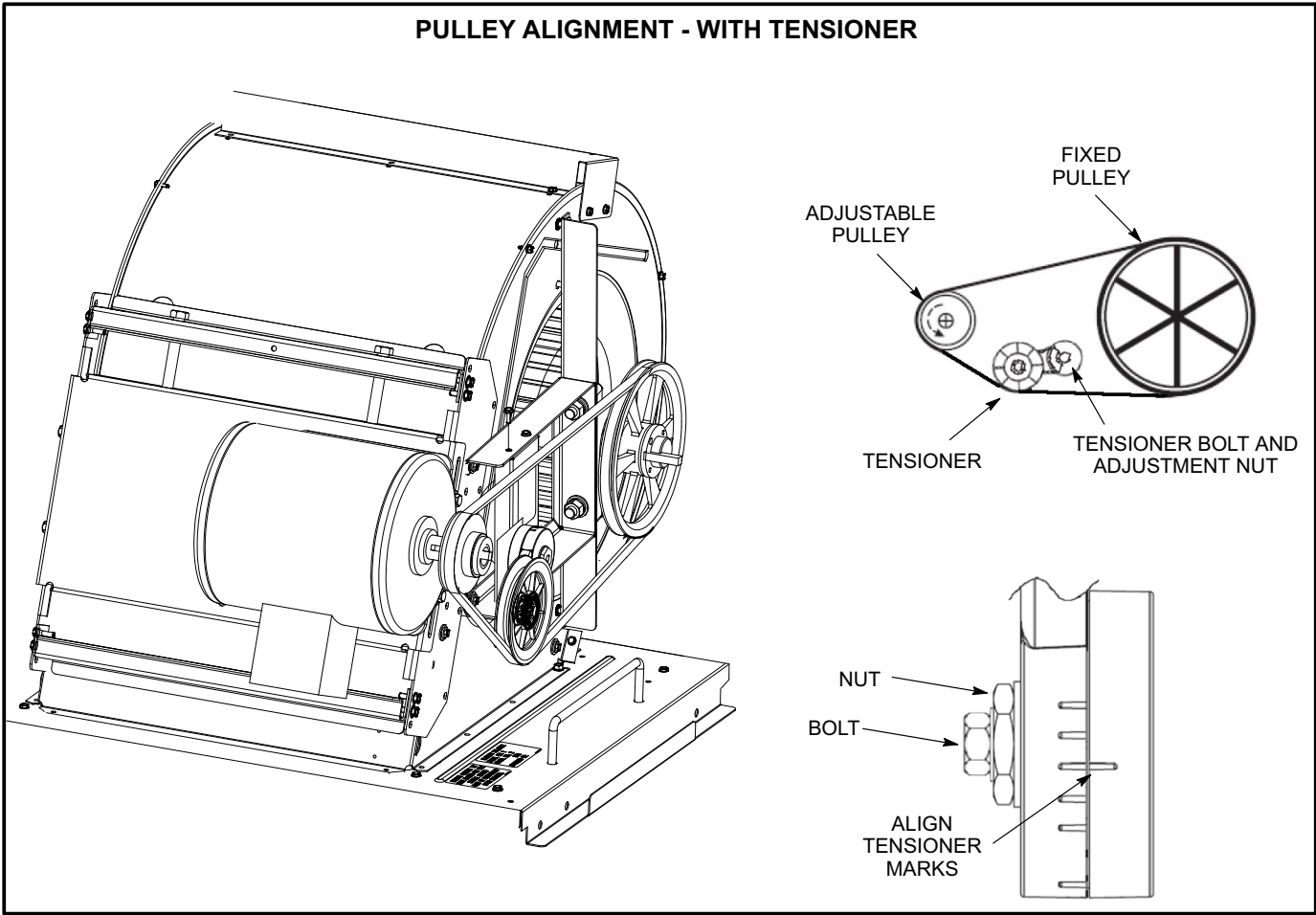

FIGURE 18

Blowers Equipped With Belt Tensioner

- 1- Loosen the bolt in the center of the tensioner. See figure 18.
- 2- Place belt over all three pulleys.
- 3- Using a 15/16" wrench, turn the tensioner nut until marks align as shown in figure 18.
- 4- Hold the tensioner with marks aligned and tighten the bolt to 23 ft.lbs. using the 9/16" wrench.

E-Check Belt Tension

Overtensioning belts shortens belt and bearing life. Check belt tension as follows:

- 1- Measure span length X. See figure 19.
- 2- Apply perpendicular force to center of span (X) with enough pressure to deflect belt 1/64" for every inch of span length or 1.5mm per 100mm of span length.

Example: Deflection distance of a 40" span would be 40/64" or 5/8".

Example: Deflection distance of a 400mm span would be 6mm.

- 3- Measure belt deflection force. For a used belt, the deflection force should be 5 lbs. (35kPa) . A new belt deflection force should be 7 lbs. (48kPa).

A force below these values indicates an undertensioned belt. A force above these values indicates an overtensioned belt.

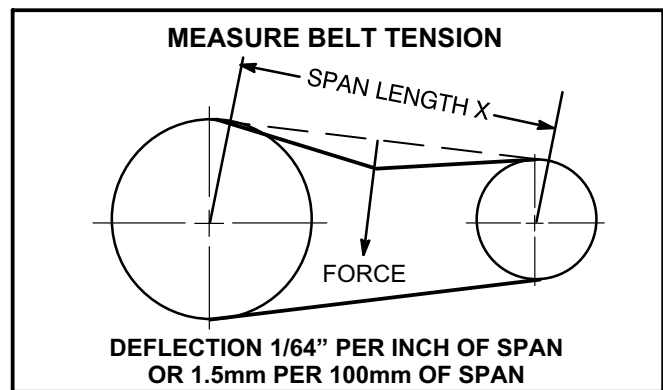

FIGURE 19

F-Field-Furnished Blower Drives

For field-furnished blower drives, use page 17 or 18 to determine BHP and RPM required. Reference table 4 to determine the manufacturer's model number.

BLOWER DATA

BLOWER TABLE INCLUDES RESISTANCE FOR BASE UNIT ONLY WITH DRY INDOOR COIL & AIR FILTERS IN PLACE. FOR ALL UNITS ADD:

1 - Wet indoor coil air resistance of selected unit. 2 - Any factory installed options air resistance (heat section, Economizer, etc.) 3 - Any field installed accessories air resistance (heat section, duct resistance, diffuser, etc.)

Then determine from blower table blower motor output and drive required.

See page 17 for wet coil and option/accessory air resistance data.

See page 17 for factory installed drive kit specifications.

MINIMUM AIR VOLUME REQUIRED FOR DIFFERENT GAS HEAT SIZES

Low (L), Standard (S) and Medium Heat (M) - 4500 cfm minimum. High Heat (H) - 5125 cfm minimum

MINIMUM AIR VOLUME REQUIRED FOR USE WITH OPTIONAL ELECTRIC HEAT

LCM156 units require 5200cfm minimum air with electric heat and 180-300 units require 6000 cfm minimum air with electric heat.

TOTAL STATIC PRESSURE - Inches Water Gauge (Pa)

Air Volume cfm	0.20		0.40		0.60		0.80		1.00		1.20		1.40		1.60		1.80		2.00		2.20		2.40		2.60			
	RPM	BHP	RPM	BHP	RPM	BHP	RPM	BHP	RPM	BHP	RPM	BHP	RPM	BHP	RPM	BHP	RPM	BHP	RPM	BHP	RPM	BHP	RPM	BHP	RPM	BHP		
2750	385	0.30	505	0.50	600	0.70	680	0.90	755	1.10	820	1.30	885	1.50	950	1.70	1005	1.90	1060	2.10	1110	2.30	1160	2.50	1210	2.70	1260	2.90
3000	395	0.35	515	0.55	610	0.75	685	1.00	760	1.20	825	1.45	890	1.65	955	1.85	1010	2.05	1065	2.25	1115	2.45	1165	2.65	1215	2.85	1265	3.05
3250	405	0.40	520	0.60	615	0.85	695	1.10	765	1.30	830	1.60	895	1.80	960	2.00	1015	2.20	1070	2.40	1120	2.60	1170	2.80	1220	3.00	1270	3.20
3500	415	0.45	530	0.70	620	0.95	700	1.20	775	1.45	840	1.70	900	1.90	965	2.10	1020	2.30	1075	2.50	1125	2.70	1175	2.90	1225	3.10	1275	3.30
3750	425	0.50	540	0.75	630	1.05	710	1.30	780	1.60	845	1.85	905	2.05	970	2.25	1025	2.45	1080	2.65	1130	2.85	1180	3.05	1230	3.25	1280	3.45
4000	435	0.55	545	0.85	635	1.10	715	1.40	785	1.70	850	2.00	910	2.20	975	2.40	1030	2.60	1085	2.80	1135	3.00	1185	3.20	1235	3.40	1285	3.60
4250	445	0.60	555	0.90	645	1.25	725	1.55	795	1.85	855	2.15	915	2.35	980	2.55	1035	2.75	1090	2.95	1140	3.15	1190	3.35	1240	3.55	1290	3.75
4500	455	0.70	565	1.00	655	1.35	730	1.65	800	2.00	865	2.35	925	2.55	990	2.75	1045	2.95	1100	3.15	1150	3.35	1200	3.55	1250	3.75	1300	3.95
4750	470	0.75	575	1.10	660	1.45	740	1.80	810	2.15	870	2.50	930	2.70	995	2.90	1050	3.10	1105	3.30	1155	3.50	1205	3.70	1255	3.90	1305	4.10
5000	480	0.85	585	1.25	670	1.60	750	1.95	815	2.30	880	2.70	940	2.90	1005	3.10	1060	3.30	1115	3.50	1165	3.70	1215	3.90	1265	4.10	1315	4.30
5250	495	0.95	595	1.35	680	1.70	755	2.10	825	2.50	890	2.90	945	3.10	1010	3.30	1065	3.50	1120	3.70	1170	3.90	1220	4.10	1270	4.30	1320	4.50
5500	505	1.05	605	1.45	690	1.85	765	2.25	835	2.65	895	3.05	955	3.25	1015	3.45	1070	3.65	1125	3.85	1175	4.05	1225	4.25	1275	4.45	1325	4.65
5750	520	1.15	615	1.60	700	2.00	775	2.45	840	2.85	905	3.25	960	3.45	1020	3.65	1075	3.85	1130	4.05	1180	4.25	1230	4.45	1280	4.65	1330	4.85
6000	530	1.30	630	1.75	710	2.15	785	2.60	850	3.05	910	3.45	970	3.65	1030	3.85	1085	4.05	1140	4.25	1190	4.45	1240	4.65	1290	4.85	1340	5.05
6250	545	1.40	640	1.90	720	2.35	795	2.80	860	3.25	920	3.70	975	3.90	1035	4.10	1090	4.30	1145	4.50	1195	4.70	1245	4.90	1295	5.10	1345	5.30
6500	560	1.55	650	2.05	730	2.50	805	3.00	870	3.45	930	3.95	985	4.15	1045	4.35	1100	4.55	1155	4.75	1205	4.95	1255	5.15	1305	5.35	1355	5.55
6750	570	1.70	665	2.20	745	2.70	815	3.20	880	3.70	940	4.20	995	4.40	1055	4.60	1110	4.80	1165	5.00	1215	5.20	1265	5.40	1315	5.60	1365	5.80
7000	585	1.85	675	2.35	755	2.90	825	3.40	890	3.95	950	4.45	1005	4.65	1065	4.85	1120	5.05	1175	5.25	1225	5.45	1275	5.65	1325	5.85	1375	6.05
7250	600	2.00	690	2.60	765	3.10	835	3.65	900	4.15	955	4.65	1010	4.85	1070	5.05	1125	5.25	1180	5.45	1230	5.65	1280	5.85	1330	6.05	1380	6.25
7500	615	2.20	700	2.75	775	3.30	845	3.85	910	4.45	965	4.95	1020	5.15	1080	5.35	1135	5.55	1190	5.75	1240	5.95	1290	6.15	1340	6.35	1390	6.55
7750	630	2.40	715	3.00	790	3.55	855	4.10	920	4.70	975	5.25	1030	5.45	1090	5.65	1145	5.85	1200	6.05	1250	6.25	1300	6.45	1350	6.65	1400	6.85
8000	640	2.55	725	3.20	800	3.80	865	4.35	930	4.95	985	5.50	1040	5.70	1100	5.90	1155	6.10	1210	6.30	1260	6.50	1310	6.70	1360	6.90	1410	7.10
8250	655	2.80	740	3.40	810	4.00	880	4.65	940	5.25	995	5.85	1050	6.05	1110	6.25	1165	6.45	1220	6.65	1270	6.85	1320	7.05	1370	7.25	1420	7.45
8500	670	3.00	750	3.65	825	4.30	890	4.90	950	5.55	1005	6.15	1060	6.35	1120	6.55	1175	6.75	1230	6.95	1280	7.15	1330	7.35	1380	7.55	1430	7.75
8750	685	3.25	765	3.90	835	4.55	900	5.20	960	5.85	1015	6.45	1070	6.65	1130	6.85	1185	7.05	1240	7.25	1290	7.45	1340	7.65	1390	7.85	1440	8.05
9000	700	3.50	780	4.20	850	4.85	910	5.50	970	6.15	1025	6.80	1080	7.00	1140	7.20	1195	7.40	1250	7.60	1300	7.80	1350	8.00	1400	8.20	1450	8.40
9250	715	3.75	790	4.45	860	5.15	925	5.85	985	6.55	1040	7.20	1095	7.40	1155	7.60	1210	7.80	1260	8.00	1310	8.20	1360	8.40	1410	8.60	1460	8.80
9500	730	4.00	805	4.75	875	5.45	935	6.15	995	6.90	1050	7.60	1105	7.80	1165	8.00	1220	8.20	1270	8.40	1320	8.60	1370	8.80	1420	9.00	1470	9.20
9750	745	4.30	820	5.05	885	5.75	950	6.55	1005	7.20	1060	7.95	1110	8.15	1170	8.35	1225	8.55	1275	8.75	1325	8.95	1375	9.15	1425	9.35	1475	9.55
10,000	760	4.60	835	5.40	900	6.15	960	6.85	1015	7.60	1070	8.35	1120	8.55	1180	8.75	1235	8.95	1285	9.15	1335	9.35	1385	9.55	1435	9.75	1485	9.95
10,250	775	4.90	845	5.65	910	6.45	970	7.20	1030	8.00	1080	8.75	1135	8.95	1190	9.15	1245	9.35	1295	9.55	1345	9.75	1395	9.95	1445	10.15	1495	10.35
10,500	790	5.20	860	6.00	925	6.85	985	7.65	1040	8.40	1095	9.20	1145	9.40	1200	9.60	1255	9.80	1305	10.00	1355	10.20	1405	10.40	1455	10.60	1505	10.80
10,750	805	5.55	875	6.40	940	7.25	1000	8.05	1055	8.85	1105	9.65	1155	9.85	1210	10.05	1265	10.25	1315	10.45	1365	10.65	1415	10.85	1465	11.05	1515	11.25
11,000	820	5.90	890	6.80	950	7.60	1010	8.45	1065	9.30	1115	10.05	1165	10.25	1220	10.45	1275	10.65	1325	10.85	1375	11.05	1425	11.25	1475	11.45	1525	11.65

BLOWER DATA

FACTORY INSTALLED BELT DRIVE KIT SPECIFICATIONS

Motor Efficiency	Nominal hp	Maximum hp	Drive Kit Number	RPM Range
Standard or High	2	2.30	1	535 - 725
Standard or High	2	2.30	2	710 - 965
Standard	3	3.45	1	535 - 725
Standard	3	3.45	2	710 - 965
High	3	3.45	3	685 - 856
High	3	3.45	4	850 - 1045
Standard	5	5.75	3	685 - 856
Standard	5	5.75	4	850 - 1045
Standard	5	5.75	5	945 - 1185
Standard	7.5	8.63	6	850 - 1045
Standard	7.5	8.63	7	945 - 1185
Standard	7.5	8.63	8	1045 - 1285
Standard	10	11.50	7	945 - 1185
Standard	10	11.50	10	1045 - 1285
Standard	10	11.50	11	1135 - 1365

NOTE - Using total air volume and system static pressure requirements determine from blower performance tables rpm and motor output required. Maximum usable output of motors furnished are shown. In Canada, nominal motor output is also maximum usable motor output. If motors of comparable output are used, be sure to keep within the service factor limitations outlined on the motor nameplate.

NOTE - Units equipped with Multi-Stage Air Volume option are limited to a motor service factor of 1.0.

FACTORY INSTALLED OPTIONS/FIELD INSTALLED ACCESSORY AIR RESISTANCE

Air Volume cfm	Wet Indoor Coil		Condenser Reheat Coil	Gas Heat Exchanger			Electric Heat	Econo- mizer	Filters		Horizontal Roof Curb	
	156, 180	210, 240, 300		Low/ Standard Heat	Medium Heat	High Heat			156U thru 240U	300U		
	in. w.g.	in. w.g.	in. w.g.	in. w.g.	in. w.g.	in. w.g.	in. w.g.	MERV 8			MERV 13	in. w.g.
2750	.01	.02	.01	.02	.04	.05	---	---	.01	.03	.03	-
3000	.01	.02	.01	.03	.04	.05	---	---	.01	.03	.04	-
3250	.01	.03	.01	.03	.05	.06	---	---	.01	.04	.04	.01
3500	.01	.03	.02	.03	.05	.06	---	---	.01	.04	.05	.01
3750	.01	.03	.02	.04	.06	.07	---	---	.01	.04	.05	.01
4000	.02	.04	.02	.04	.06	.07	---	---	.01	.04	.06	.02
4250	.02	.04	.02	.04	.06	.08	---	---	.01	.05	.07	.02
4500	.02	.05	.02	.05	.07	.09	---	---	.01	.05	.07	.02
4750	.02	.05	.02	.05	.08	.10	---	---	.02	.05	.08	.03
5000	.02	.05	.02	.05	.09	.11	---	---	.02	.06	.08	.03
5250	.02	.06	.03	.06	.10	.12	---	---	.02	.06	.09	.04
5500	.02	.07	.03	.06	.10	.13	---	---	.02	.06	.10	.04
5750	.03	.07	.03	.06	.11	.14	---	---	.02	.07	.11	.05
6000	.03	.08	.03	.07	.12	.15	.01	---	.03	.07	.11	.06
6250	.03	.08	.03	.07	.12	.16	.01	.01	.03	.07	.12	.07
6500	.03	.09	.04	.08	.13	.17	.01	.02	.03	.08	.13	.08
6750	.04	.10	.04	.08	.14	.18	.01	.03	.03	.08	.14	.08
7000	.04	.10	.04	.09	.15	.19	.01	.04	.04	.08	.15	.09
7250	.04	.11	.04	.09	.16	.20	.01	.05	.04	.09	.16	.10
7500	.05	.12	.05	.10	.17	.21	.01	.06	.04	.09	.17	.11
8000	.05	.13	.05	.11	.19	.24	.02	.09	.05	.10	.19	.13
8500	.06	.15	.05	.12	.20	.26	.02	.11	.05	.10	.21	.15
9000	.07	.16	.06	.13	.23	.29	.04	.14	.06	.11	.24	.17
9500	.08	.18	.07	.14	.25	.32	.05	.16	.07	.12	.26	.19
10,000	.08	.20	.07	.16	.27	.35	.06	.19	.07	.12	.29	.21
10,500	.09	.22	.08	.17	.30	.38	.09	.22	.08	.13	.31	.24
11,000	.11	.24	.08	.18	.31	.40	.11	.25	.09	.14	.34	.27

**TABLE 4
MANUFACTURER'S NUMBERS**

Drive No.	H.P.	DRIVE COMPONENTS											
		RPM		ADJUSTABLE SHEAVE		FIXED SHEAVE		BELTS (STD.)		BELTS (WITH TENSIONER)		SPLIT BUSHING	
		Min	Max	Supplier No.	OEM Part No.	Supplier No.	OEM Part No.	Supplier No.	OEM Part No.	Supplier No.	OEM Part No.	Supplier No.	OEM Part No.
1	2 & 3 Std.	535	725	1VP40x7/8	79J0301	BK95 x 1-3/16	105617-02	BX59	59A5001	BX60	100245-10	N/A	N/A
2	2 & 3 Std.	710	965	1VP40x7/8	79J0301	BK72 x 1-3/16	105617-01	BX55	63K0501	BX57	78L5301	N/A	N/A
3	3 High & 5	685	865	1VP50x1-1/8	P-8-1977	BK100 x 1-3/16	105617-03	BX61	93J9801	5VX660	100245-20	N/A	N/A
4	3 High & 5	850	1045	1VP65x1-1/8	100239-03	BK110H	100788-06	BX65	100245-08	BX66	97J5901	H-1-3/16	105616-02
5	5	945	1185	1VP60x1-1/8	41C1301	BK90H x 1-7/16	100788-04	BX61	93J9801	BX62	57A7701	H-1-3/16	105616-02
6	7.5	850	1045	1VP65x1-3/8	78M7101	BK110H	100788-06	BX66	97J5901	BX67	100245-09	H-1-3/16	105616-02
7	7.5 & 10	945	1185	1VP60x1-3/8	78L5501	BK90H x 1-7/16	100788-04	BX62	57A7701	BX64	97J5801	H-1-3/16	105616-02
8	7.5	1045	1285	1VP65x1-3/8	78M7101	BK90H x 1-7/16	100788-04	BX64	97J5801	5VX670	100245-21	H-1-3/16	105616-02
10	10	1045	1285	1VP65x1-3/8	78M7101	1B5V86	78M8301	5VX660	100245-20	5VX670	100245-21	B-1-3/16	105616-01
11	10	1135	1365	1VP65x1-3/8	78M7101	1B5V80	100240-05	5VX660	100245-20	5VX660	100245-20	B-1-3/16	105616-01

Cooling Start-Up

IMPORTANT-The crankcase heater must be energized for 24 hours before attempting to start compressor. Set thermostat so there is no demand to prevent compressors from cycling. Apply power to unit.

NOTE - These units must not be used as a “construction heater” at any time during any phase of construction. Very low return air temperatures, harmful vapors and misplacement of the filters will damage the unit and its efficiency. Additionally, a unit which will be subject to cold temperatures when not in operation must have a vapor barrier installed to seal the duct connections. Failure to protect the unit from moisture laden air or harmful vapors (generated from the construction process and temporary combustion heating equipment) will cause corrosive condensation within the unit. Failure to properly protect the unit in this situation will cause electrical and electronic component failure and could affect the unit warranty status.

A-Preliminary Checks

- 1- Make sure that unit is installed in accordance with the installation instructions and applicable codes.
- 2- Inspect all electrical wiring, both field- and factory-installed, for loose connections. Tighten as required.
- 3- Check to ensure that refrigerant lines do not rub against the cabinet or against other refrigerant lines.
- 4- Check voltage at disconnect switch. Voltage must be within range listed on nameplate. If not, consult power company and have voltage condition corrected before starting unit.
- 5- Make sure filters are in place before start-up.

B-Start-Up

Supply Air Staged Blower - Refer to the Multi-Staged Air Volume Start-Up section.

- 1- Initiate first and second stage cooling demands using this mobile service app menu path:
SERVICE > TEST > COOLING > COOL4
Instructions provided with the thermostat may also be used to initiate cooling.

2- First-stage thermostat demand will energize indoor blower in Low Cooling CFM. Second-stage thermostat demand will energize indoor blower in High Cooling CFM. Both demands energize compressor 1 (variable speed compressor). The remaining compressors will be energized to modulate the discharge air temperature.

3- 156, 180 -

Units contain three refrigerant circuits or systems. See figure 20.

210, 240, 300 -

Units contain four refrigerant circuits or systems. See figure 21.

4- Each refrigerant circuit is separately charged with R410A refrigerant. See unit rating plate for correct amount of charge.

5- Refer to the *Refrigerant Check and Charge* section to check refrigerant charge.

C-R410A Refrigerant

Units charged with R410A refrigerant operate at much higher pressures than R22. The expansion valve and liquid line drier provided with the unit are approved for use with R410A. Do not replace them with components designed for use with R22.

R410A refrigerant is stored in a pink cylinder.

▲ IMPORTANT

Mineral oils are not compatible with R410A. If oil must be added, it must be a polyol ester oil.

Manifold gauge sets used with systems charged with R410A refrigerant must be capable of handling the higher system operating pressures. The gauges should be rated for use with pressures of 0-800 on the high side and a low side of 30” vacuum to 250 psi with dampened speed to 500 psi. Gauge hoses must be rated for use at up to 800 psi of pressure with a 4000 psi burst rating.

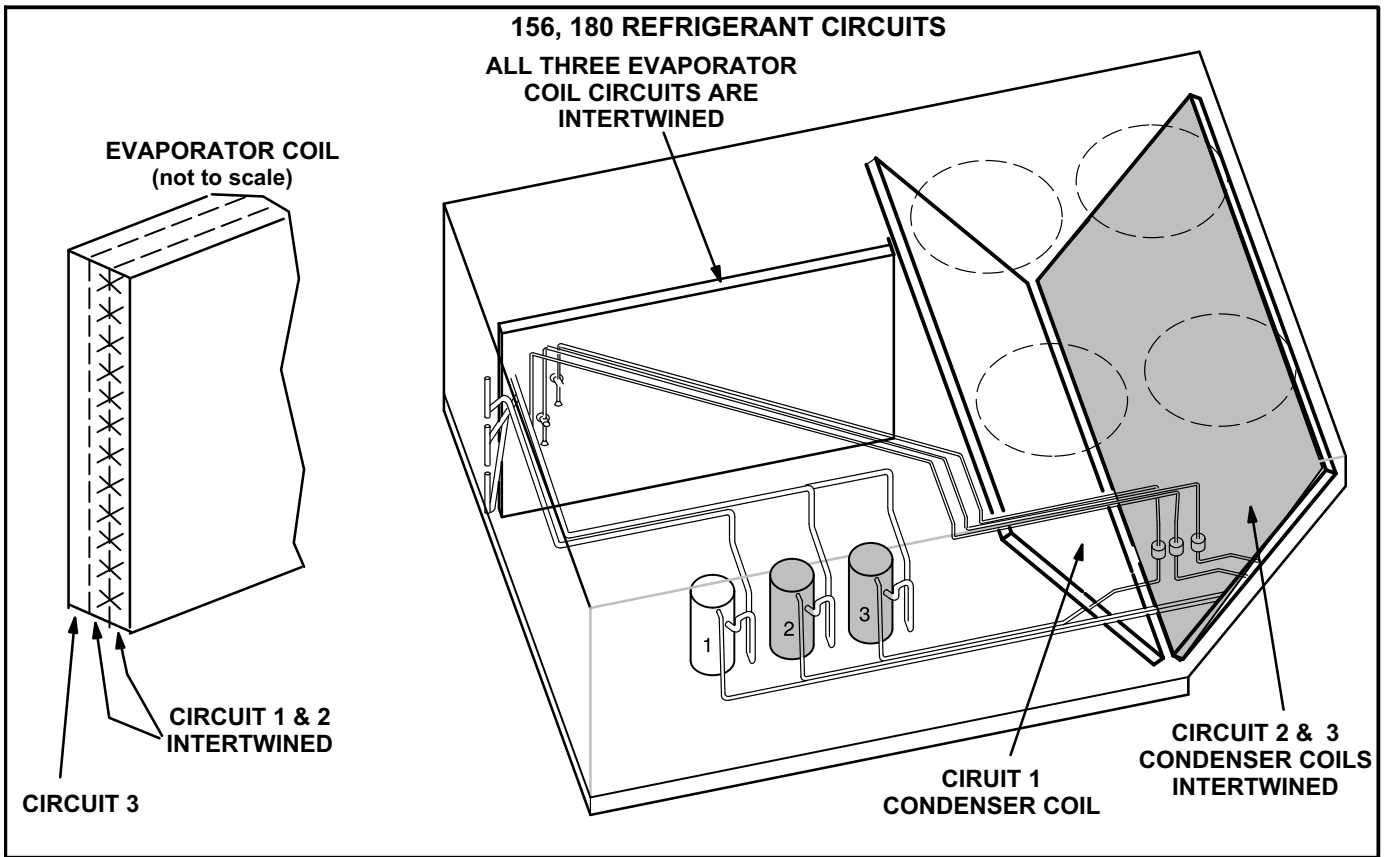

FIGURE 20

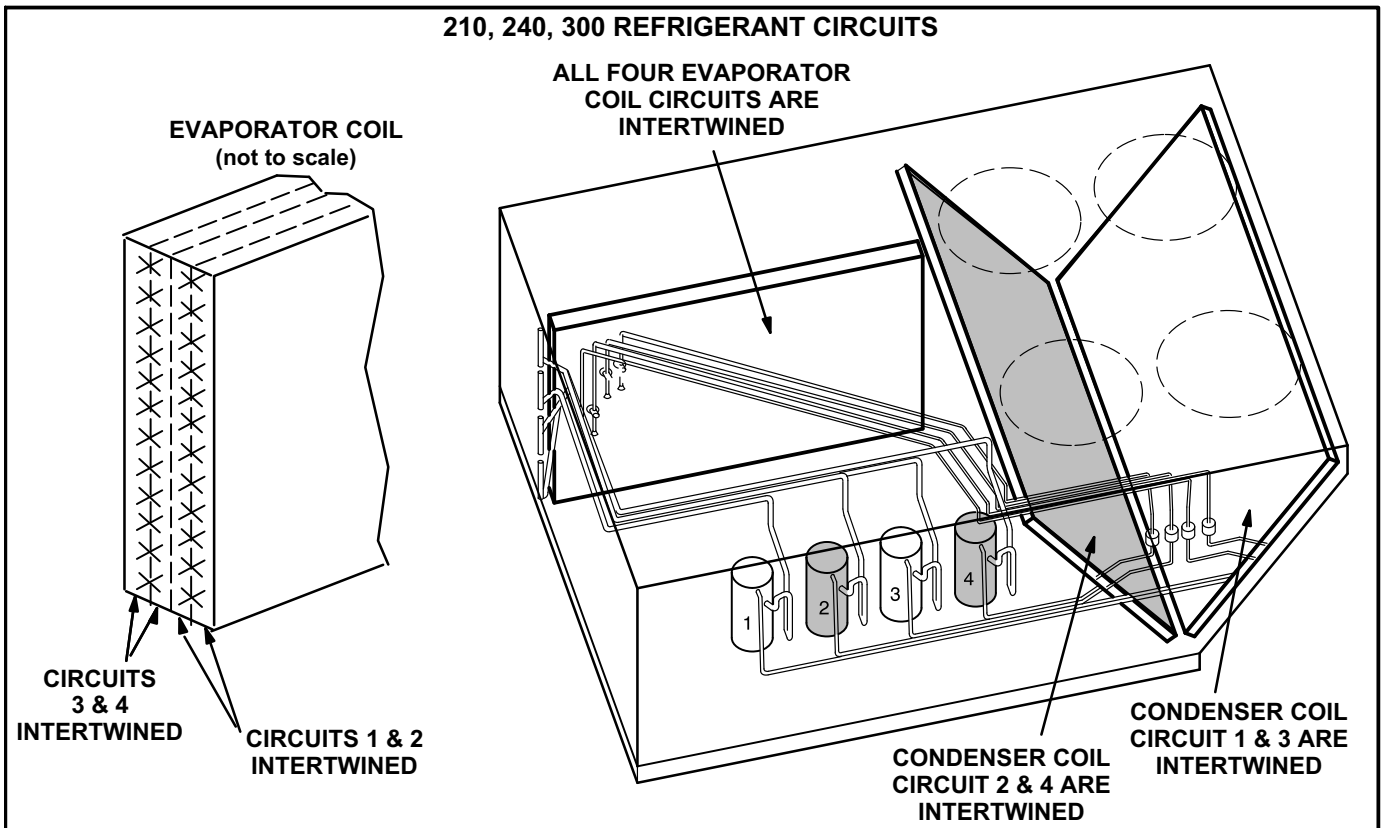

FIGURE 21

D-Refrigerant Charge and Check - Fin/Tube Coil

WARNING-Do not exceed nameplate charge under any condition. This unit is factory charged and should require no further adjustment. If the system requires additional refrigerant, reclaim the charge, evacuate the system and add required nameplate charge.

NOTE - System charging is not recommended below 60°F (15°C). In temperatures below 60°F (15°C), the charge *must* be weighed into the system.

If weighing facilities are not available, or to check the charge, use the following procedure:

IMPORTANT - Charge unit in normal cooling mode.

- 1- Attach gauge manifolds to discharge and suction lines. With the economizer disabled, operate the unit in **cooling mode at high speed** using the following mobile service app menu path:
SERVICE>TEST>COOL>COOL 4
- 2- Use a thermometer to accurately measure the outdoor ambient temperature.
- 3- Apply the outdoor temperature to tables 5 through 14 to determine normal operating pressures. Pressures are listed for sea level applications at 80°F dry bulb and 67°F wet bulb return air.
- 4- Compare the normal operating pressures to the pressures obtained from the gauges. Minor variations in these pressures may be expected due to differences in installations. Significant differences could mean that the system is not properly charged or that a problem exists with some component in the system. **Correct any system problems before proceeding.**
- 5- If discharge pressure is high, remove refrigerant from the system. If discharge pressure is low, add refrigerant to the system.
 - Add or remove charge in increments.
 - Allow the system to stabilize each time refrigerant is added or removed.
- 6- Use the following approach method along with the normal operating pressures to confirm readings.

TABLE 5

156 Std. Compressor 1 Frequency 56Hz - 581014-01

Outdoor Coil Entering Air Temp	Circuit 1		Circuit 2		Circuit 3	
	Dis. ±10 psig	Suc. ±5 psig	Dis. ±10 psig	Suc. ±5 psig	Dis. ±10 psig	Suc. ±5 psig
65°F	228	127	256	131	258	140
75°F	267	130	295	134	298	148
85°F	309	133	337	136	340	153
95°F	352	135	383	139	387	156
105°F	403	139	432	142	433	159
115°F	457	142	485	145	486	162

TABLE 6

156 Reheat Compressor 1 Frequency 56Hz - 581015-01

Outdoor Coil Entering Air Temp	Circuit 1		Circuit 2		Circuit 3	
	Disch. ±10 psig	Suct. ±5 psig	Disch. ±10 psig	Suct. ±5 psig	Disch. ±10 psig	Suct. ±5 psig
65°F	230	123	274	127	260	140
75°F	267	126	313	129	299	144
85°F	309	129	353	132	341	147
95°F	355	133	398	135	385	150
105°F	404	135	447	137	432	153
115°F	463	139	507	140	485	156

TABLE 7

180 Std. Compressor 1 Frequency 56Hz - 581016-01

Outdoor Coil Entering Air Temp	Circuit 1		Circuit 2		Circuit 3	
	Disch. ±10 psig	Suct. ±5 psig	Disch. ±10 psig	Suct. ±5 psig	Disch. ±10 psig	Suct. ±5 psig
65°F	232	123	276	131	279	141
75°F	267	129	313	133	315	147
85°F	311	132	360	136	362	151
95°F	357	135	406	138	408	154
105°F	403	137	456	141	455	158
115°F	456	140	511	144	510	161

TABLE 8

180 Reheat Compressor 1 Frequency 56Hz - 581017-01

Outdoor Coil Entering Air Temp	Circuit 1		Circuit 2		Circuit 3	
	Disch. ±10 psig	Suct. ±5 psig	Disch. ±10 psig	Suct. ±5 psig	Disch. ±10 psig	Suct. ±5 psig
65°F	233	122	291	129	267	132
75°F	270	127	330	131	307	138
85°F	313	129	373	133	348	143
95°F	360	134	430	137	398	147
105°F	411	136	472	139	441	149
115°F	469	139	531	142	495	152

TABLE 9

210 Std. Compressor 1 Frequency 48Hz - 581018-01

Outdoor Coil Entering Air Temp	Circuit 1		Circuit 2		Circuit 3		Circuit 4	
	Dis ±10 psig	Suc ±5 psig	Dis. ±10 psig	Suc ±5 psig	Dis. ±10 psig	Suc ±5 psig	Dis. ±10 psig	Suc. ±5 psig
65°F	245	125	255	127	253	139	259	140
75°F	283	127	294	130	290	143	299	146
85°F	323	129	336	133	330	146	343	149
95°F	368	131	386	136	376	148	393	151
105°F	418	134	435	139	425	152	440	153
115°F	472	137	489	142	479	154	496	155

TABLE 10
210 Reheat Compressor 1 Frequency 48Hz - 581019-01

Outdoor Coil Entering Air Temp	Circuit 1		Circuit 2		Circuit 3		Circuit 4	
	Dis. +10 psig	Suc. +5 psig	Dis. +10 psig	Suc. +5 psig	Dis. +10 psig	Suc. +5 psig	Dis. +10 psig	Suc. +5 psig
65°F	245	127	267	126	241	120	264	141
75°F	279	130	303	129	279	129	301	146
85°F	317	133	344	132	318	136	342	149
95°F	367	136	393	134	365	143	391	152
105°F	407	139	438	138	409	147	438	155
115°F	461	143	492	141	462	151	493	159

TABLE 11
240 Std. Compressor 1 Frequency 62Hz - 581020-01

Outdoor Coil Entering Air Temp	Circuit 1		Circuit 2		Circuit 3		Circuit 4	
	Dis. +10 psig	Suc. +5 psig	Dis. +10 psig	Suc. +5 psig	Dis. +10 psig	Suc. +5 psig	Dis. +10 psig	Suc. +5 psig
65°F	250	117	261	124	252	129	267	139
75°F	289	121	301	128	292	136	310	146
85°F	331	124	348	131	334	140	355	151
95°F	374	126	393	134	379	142	400	154
105°F	425	130	450	138	430	145	456	158
115°F	481	133	507	141	484	148	514	161

TABLE 12
240 Reheat Compressor 1 Frequency 62Hz - 581021-01

Outdoor Coil Entering Air Temp	Circuit 1		Circuit 2		Circuit 3		Circuit 4	
	Dis. +10 psig	Suc. +5 psig	Dis. +10 psig	Suc. +5 psig	Dis. +10 psig	Suc. +5 psig	Dis. +10 psig	Suc. +5 psig
65°F	263	122	296	126	239	126	273	140
75°F	304	126	336	126	276	133	312	144
85°F	348	129	384	128	318	138	357	148
95°F	387	129	405	129	373	140	389	148
105°F	442	133	464	133	424	144	440	151
115°F	500	137	523	136	477	147	497	152

TABLE 13
300 Std. Compressor 1 Frequency 68Hz - 581022-01

Outdoor Coil Entering Air Temp	Circuit 1		Circuit 2		Circuit 3		Circuit 4	
	Dis. +10 psig	Suc. +5 psig	Dis. +10 psig	Suc. +5 psig	Dis. +10 psig	Suc. +5 psig	Dis. +10 psig	Suc. +5 psig
65°F	260	115	260	118	272	117	269	119
75°F	301	118	304	124	316	126	314	130
85°F	345	121	350	127	362	133	360	138
95°F	387	126	407	130	403	138	412	145
105°F	437	128	460	134	455	141	466	149
115°F	490	131	519	137	510	144	522	154

TABLE 14
300 Reheat Compressor 1 Frequency 68Hz - 581023-01

Outdoor Coil Entering Air Temp	Circuit 1		Circuit 2		Circuit 3		Circuit 4	
	Dis. +10 psig	Suc. +5 psig	Dis. +10 psig	Suc. +5 psig	Dis. +10 psig	Suc. +5 psig	Dis. +10 psig	Suc. +5 psig
65°F	274	121	295	120	259	114	275	120
75°F	316	124	339	122	301	123	317	128
85°F	363	126	387	124	346	131	362	135
95°F	415	129	442	127	395	137	414	141
105°F	469	132	497	130	447	142	464	144
115°F	525	136	558	133	502	145	519	147

E-Charge Verification - Approach Method - AHRI Testing (Fin/Tube Coil)

- Using the same thermometer, compare liquid temperature to outdoor ambient temperature.
 Approach Temperature = Liquid temperature (at condenser outlet) minus ambient temperature.
- Approach temperature should match values in table 15. An approach temperature greater than value shown indicates an undercharge. An approach temperature less than value shown indicates an overcharge.
- The approach method is not valid for grossly over or undercharged systems. Use tables 5 through 14 as a guide for typical operating pressures.

TABLE 15
APPROACH TEMPERATURES - FIN/TUBE COIL

Unit	Liquid Temp. Minus Ambient Temp.			
	1st Stage	2nd Stage	3rd Stage	4th Stage
156 Std.	3.0°F + 1 (1.7°C ±0.5)	6.0°F + 1 (3.3°C ±0.5)	6.5°F + 1 (3.6°C ±0.5)	NA
156 Reheat	1.7°F±1 (0.9°C±0.5)	1.7°F±1 (0.9°C±0.5)	2.7°F±1 (1.5°C±0.5)	NA
180 Std.	2.5°F + 1 (1.4°C ±0.5)	5.0°F + 1 (2.8°C ±0.5)	5.5°F + 1 (3.1°C ±0.5)	NA
180 Reheat	1.0°F + 1 (0.6°C ±0.5)	2.8°F + 1 (1.6°C ±0.5)	4.8°F + 1 (2.7°C ±0.5)	NA
210 Std.	1.0°F + 1 (0.6°C ±0.5)	5.5°F + 1 (3.1°C ±0.5)	3.0°F + 1 (1.7°C ±0.5)	6.0°F + 1 (3.3°C ±0.5)
210 Reheat	2.5°F + 1 (1.4°C ±0.5)	3.7°F + 1 (2.1°C ±0.5)	6.0°F + 1 (3.3°C ±0.5)	4.3°F + 1 (2.4°C ±0.5)
240 Std.	3.5°F + 1 (1.9°C ±0.5)	8.3°F + 1 (4.6°C ±0.5)	4.7°F + 1 (2.6°C ±0.5)	7.5°F + 1 (4.2°C ±0.5)
240 Reheat	1.9°F + 1 (1.1°C ±0.5)	3.8°F + 1 (2.1°C ±0.5)	2.2°F + 1 (1.2°C ±0.5)	5.4°F + 1 (3.0°C ±0.5)
300 Std.	1.5°F±1 (0.8°C±0.5)	5.5°F±1 (3.1°C±0.5)	4.0°F±1 (2.2°C±0.5)	6.5°F±1 (3.6°C±0.5)
300 Reheat	2.8°F±1 (1.5°C±0.5)	4.2°F±1 (2.3°C±0.5)	3.8°F±1 (2.1°C±0.5)	5.4°F±1 (3.0°C±0.5)

F-Compressor Controls

See unit wiring diagram to determine which controls are used on each unit.

- 1- High Pressure Switch (S4, S7, S28, S96)
The compressor circuit is protected by a high pressure switch which opens at 640 psig \pm 10 psig (4413 kPa \pm 70 kPa) and automatically resets at 475 psig \pm 20 psig (3275kPa \pm 138 kPa).
- 2- Low Pressure Switch (S87, S88, S97, S98)
The compressor circuit is protected by a low pressure switch. Switch opens at 40 psig \pm 5 psig (276 \pm 34 kPa) and automatically resets at 90 psig \pm 5 psig (621 kPa \pm 34 kPa).
- 3- Crankcase Heater (HR1, HR2, HR5, HR11)
Units have compressors which contain a belly band compressor oil heater which must be on 24 hours before running compressors. Energize by setting thermostat so that there is no cooling demand, to prevent compressor from cycling, and apply power to unit.
- 4- Condenser Fan Operation

156, 180

Condenser fan 3 and 4 are energized when compressor 1 is the ONLY compressor energized. As cooling demand increases, all four condenser fans are energized. See figure 22.

Condenser fans 1 and 3 are de-energized when outdoor temperature drops below 62°F (17°C).

Condenser fans 2 & 4 modulate to maintain target liquid temperatures when outdoor temperature drops below 62°F (17°C).

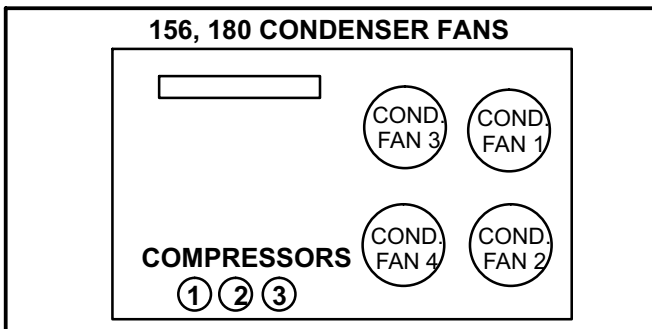

FIGURE 22

210, 240 & 300

Condenser fans 1, 2, and 3 are energized when compressor 1 or 3 are energized. As cooling demand increases, all six condenser fans are energized. Condenser fans 1, 2, 5, and 6 are energized after a 2-second delay. See figure 23.

Condenser fans 1, 2, 5, and 6 are de-energized when outdoor temperature drops below 62°F (17°C).

Condenser fan 3 is modulated to maintain target liquid temperatures (refrigerant circuits 1 and 3 respectively) when outdoor temperature drops below 62°F (17°C).

Condenser fan 4 is modulated to maintain target liquid temperatures (refrigerant circuits 2 and 4 respectively) when outdoor temperature drops below 62°F (17°C).

- 5- Temperature Thermistor Sensors (RT42-57)
Temperature thermistors are located on specific points for each refrigeration circuit. Temperature thermistors provide continuous temperature input to the unit controller for proper cooling operation as well as system protection. Controller logic will de-energize compressors for each refrigeration circuit when evaporator coil temperature falls below 32°F (0°C) to prevent evaporator freeze-up.

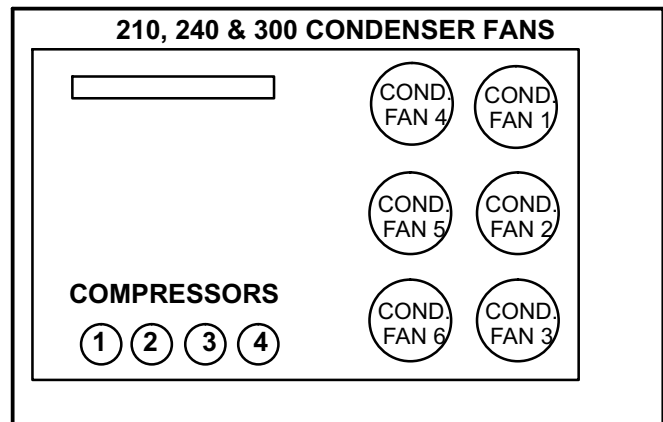

FIGURE 23

- 6- Thermal Protector (S5)
Each fixed-speed compressor is protected by an internal thermal protector switch. Variable speed compressors utilize an S5 external thermal protector.

Temperature Thermistor Sensors

Each thermistor must be specifically placed for proper unit operation and to initiate valid alarms. See table 16 for proper locations.

**TABLE 16
THERMISTOR LOCATION**

Unit	Sensor	Figure
156, 180	RT42, 43, 46, 47, 50, 54	Figure 24
210, 240, 300	RT42, 43, 46, 47, 50, 51, 54, 55	Figure 25
156, 180	RT44, 45, 48, 49, 52, 56	Figure 26
210	RT44, 45, 48, 49, 52, 53, 56, 57	Figure 27
240, 300	RT44, 45, 48, 49, 52, 53, 56, 57	Figure 28

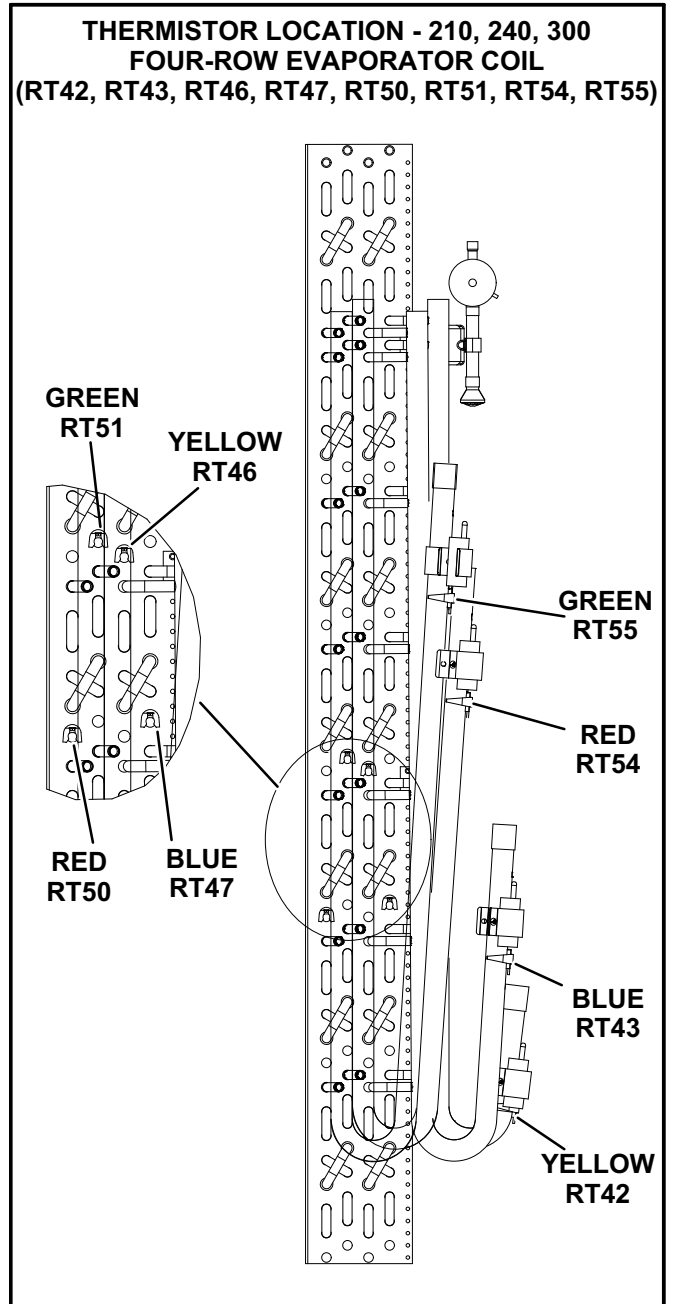
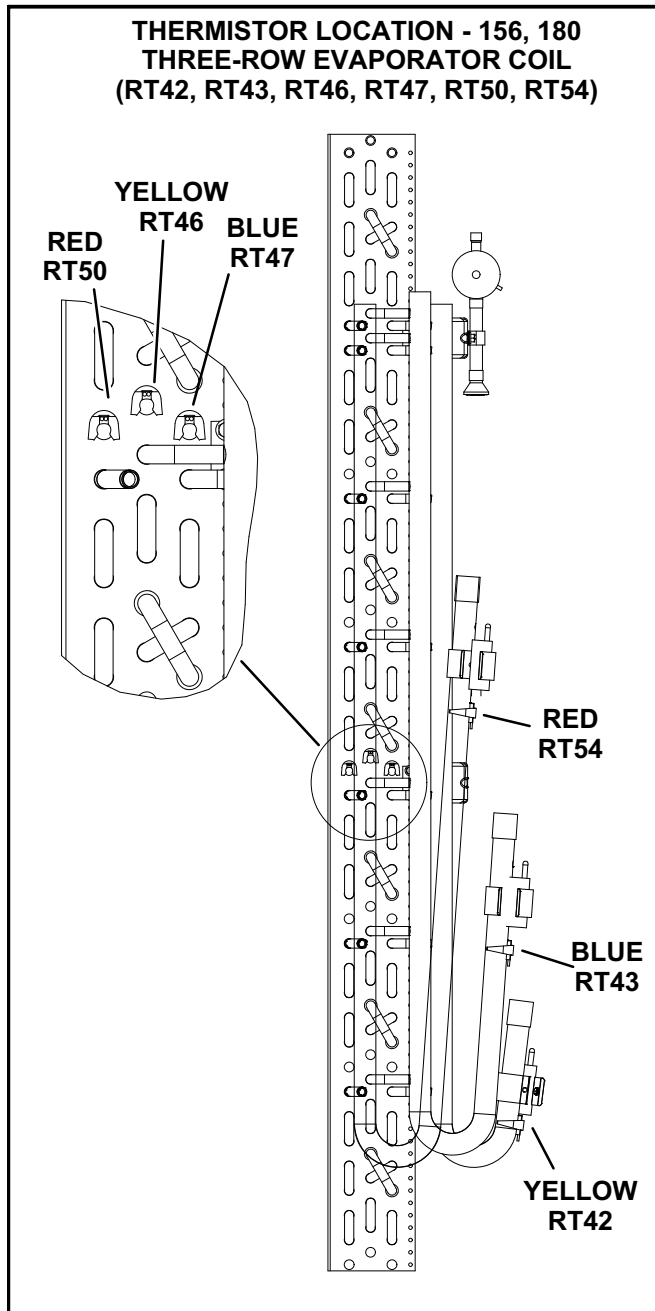

**THERMISTOR LOCATION - 156, 180
CONDENSOR COIL
(RT44, RT45, RT48, RT49, RT52, RT56)**

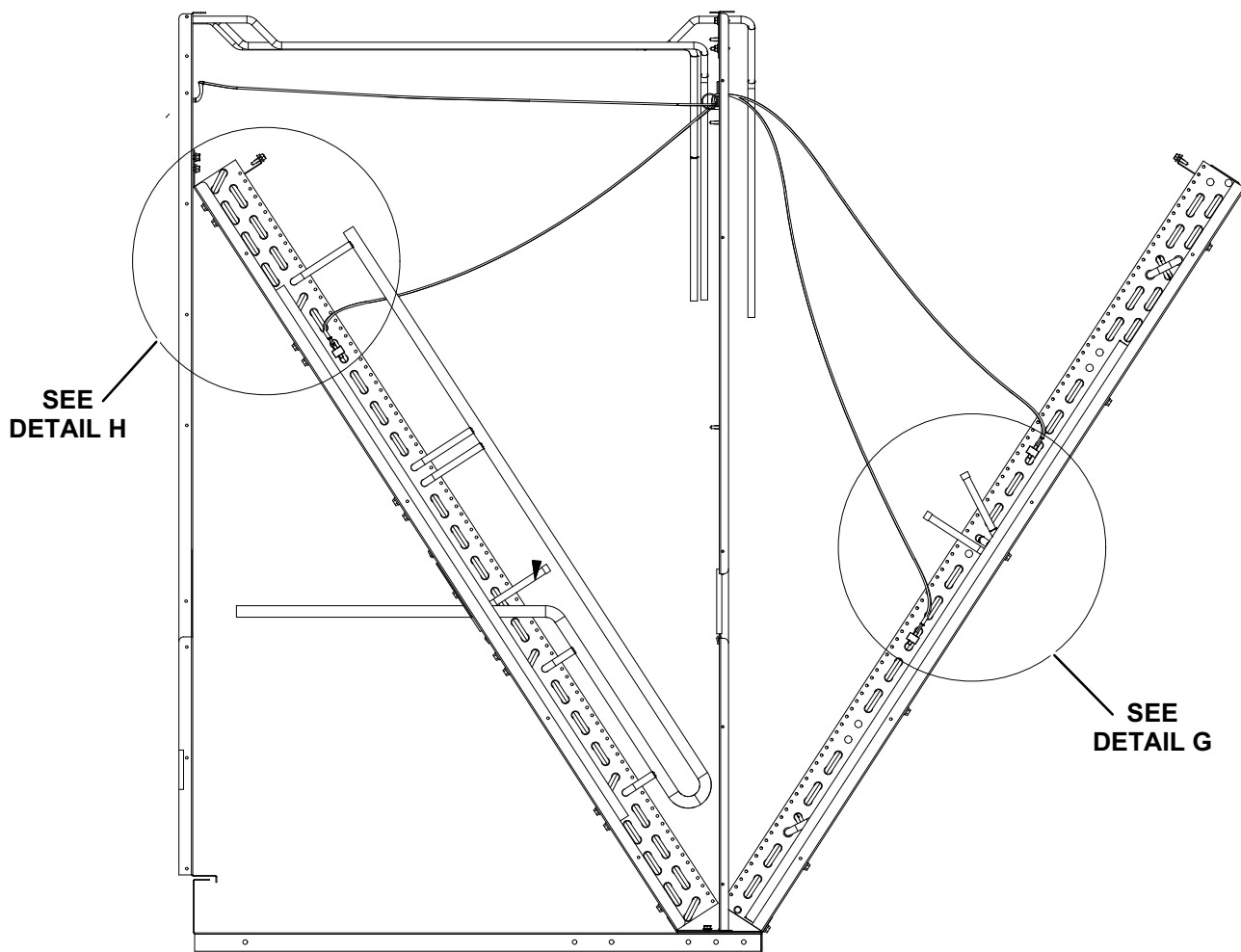
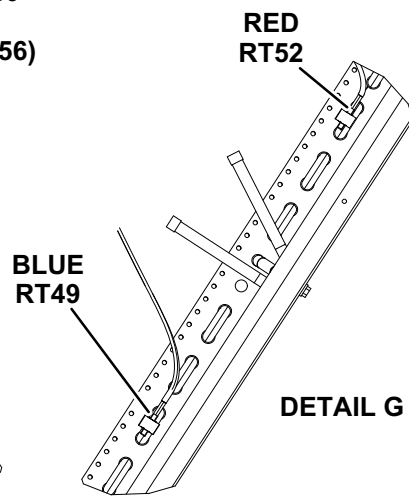
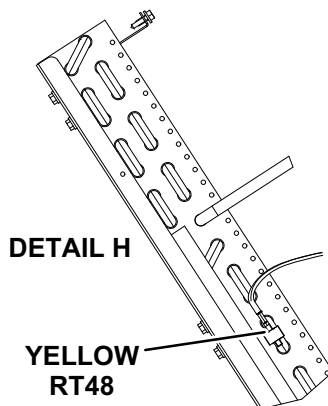
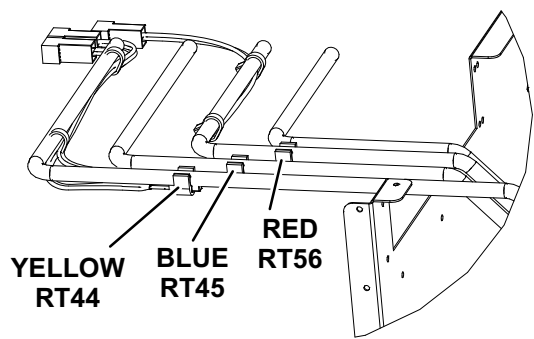

FIGURE 26

**THERMISTOR LOCATION - 210
CONDENSOR COIL
(RT44, RT45, RT48, RT49, RT52, RT53, RT56, RT57)**

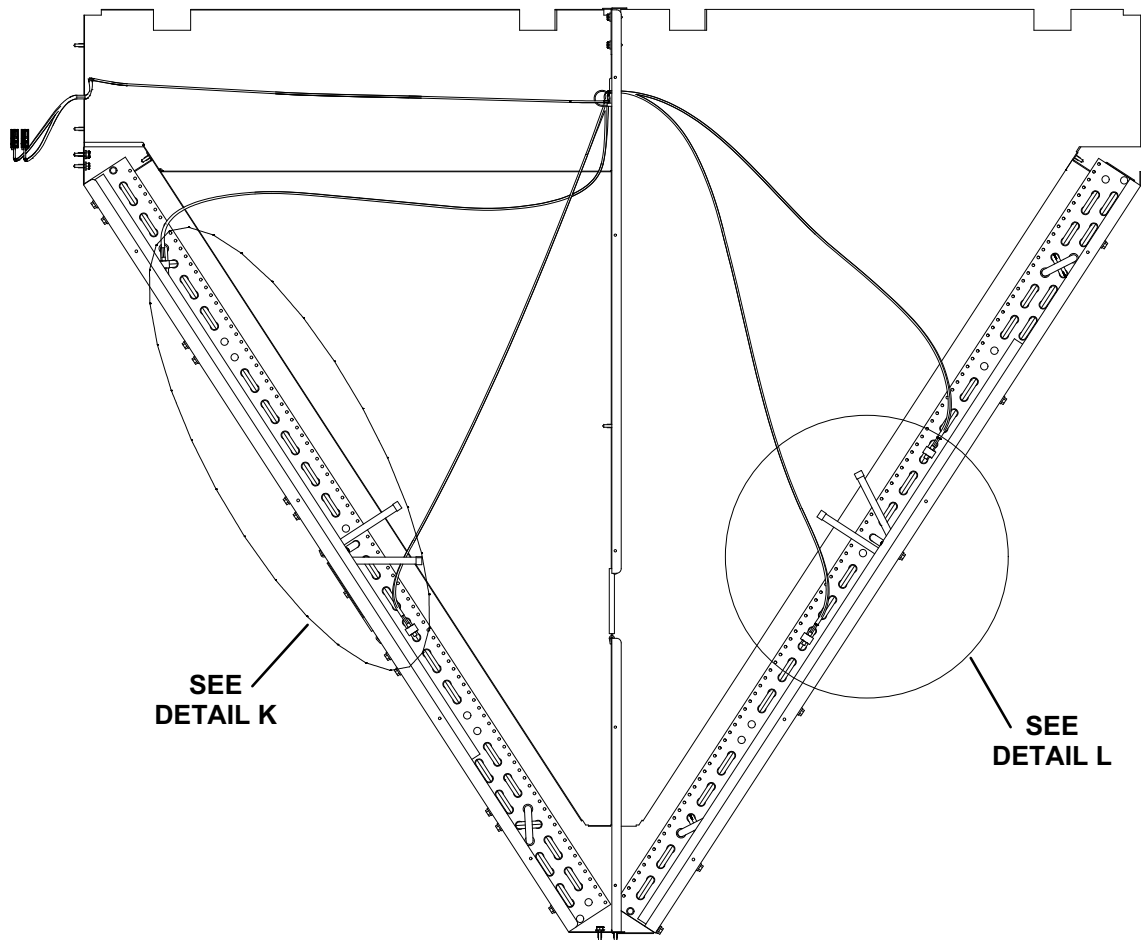
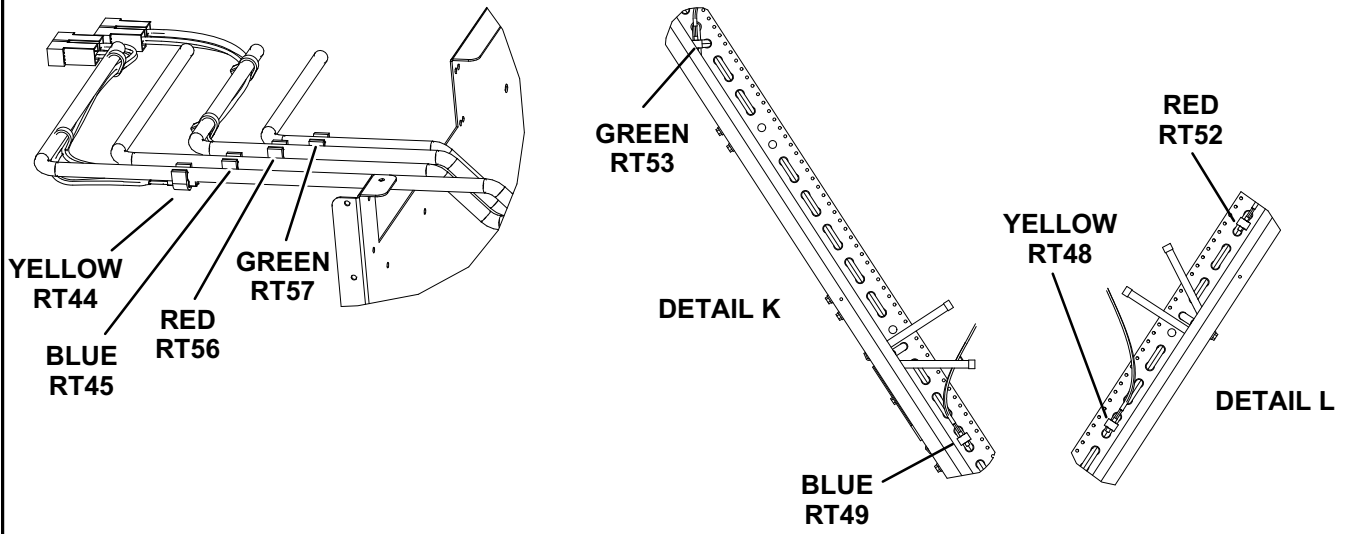

FIGURE 27
Page 26

**THERMISTOR LOCATION - 240, 300
CONDENSOR COIL
(RT44, RT45, RT48, RT49, RT52, RT53, RT56, RT57)**

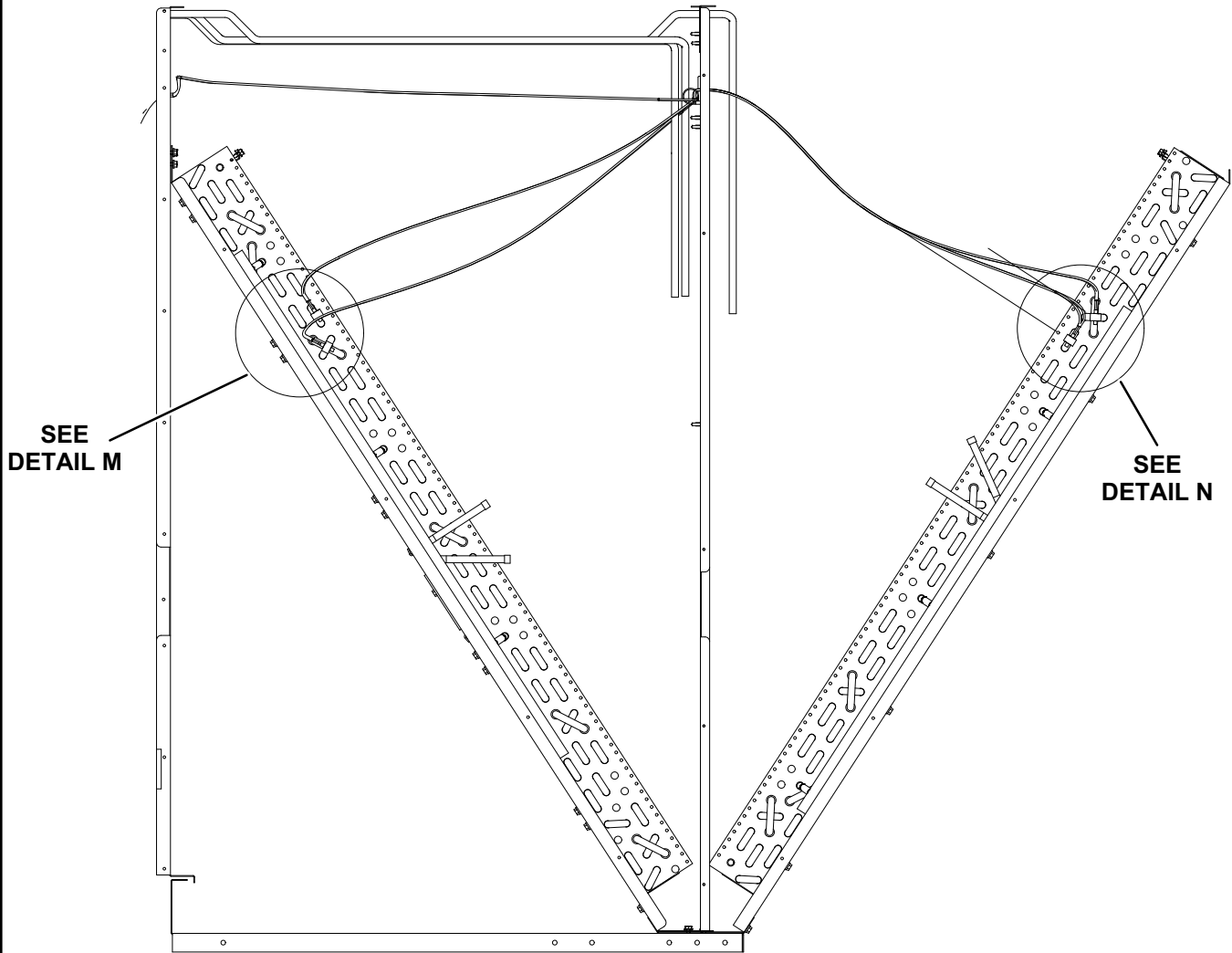
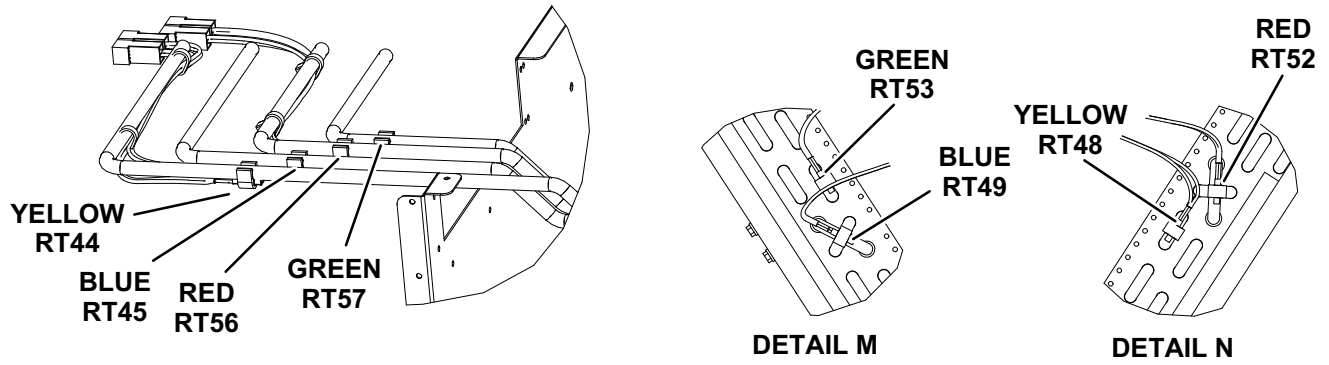

FIGURE 28
Page 27

Gas Heat Start-Up (Gas Units)

FOR YOUR SAFETY READ BEFORE LIGHTING

BEFORE LIGHTING smell all around the appliance area for gas. Be sure to smell next to the floor because some gas is heavier than air and will settle on the floor.

Use only your hand to push in or turn the gas control knob. Never use tools. If the knob will not push in or turn by hand, do not try to repair it, call a qualified service technician. Force or attempted repair may result in a fire or explosion.

This unit is equipped with an automatic spark ignition system. There is no pilot. In case of a safety shutdown, move thermostat switch to **OFF** and return the thermostat switch to **HEAT** to reset ignition control.

⚠ WARNING



Electric shock hazard. Can cause injury or death. Do not use this unit if any part has been under water. Immediately call a qualified service technician to inspect the unit and to replace any part of the control system and any gas control which has been under water.

⚠ WARNING



Danger of explosion. Can cause injury or product or property damage. If overheating occurs or if gas supply fails to shut off, shut off the manual gas valve to the appliance before shutting off electrical supply.

⚠ WARNING



Electric shock hazard. Can cause injury or death. Before attempting to perform any service or maintenance, turn the electrical power to unit **OFF** at disconnect switch(es). Unit may have multiple power supplies.

⚠ WARNING

SMOKE POTENTIAL

The heat exchanger in this unit could be a source of smoke on initial firing. Take precautions with respect to building occupants and property. Vent initial supply air outside when possible.

⚠ WARNING



Danger of explosion. Can cause injury or death. Do not attempt to light manually. Unit has a direct spark ignition system.

A-Placing Unit In Operation

⚠ WARNING



Danger of explosion and fire. Can cause injury or product or property damage. You must follow these instructions exactly.

Gas Valve Operation for Honeywell VR8205Q / VR8305Q and White Rodgers 36H54 (figure 29)

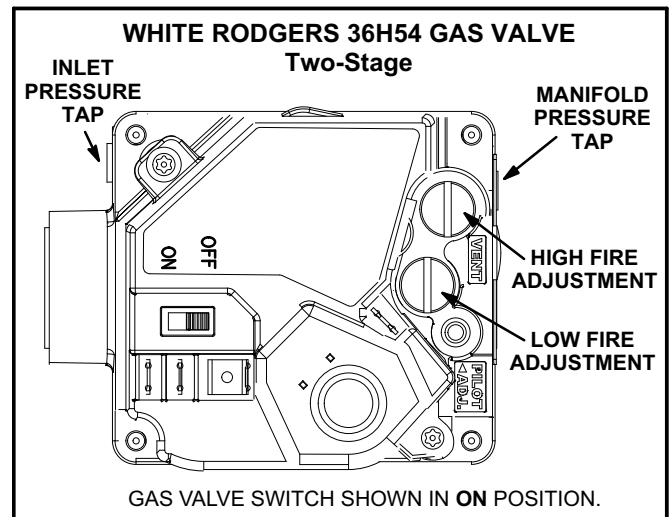



FIGURE 29

- 1- Set thermostat to lowest setting.
- 2- Turn off all electrical power to appliance.
- 3- This appliance is equipped with an ignition device which automatically lights the burner. Do **not** try to light the burner by hand.
- 4- Open or remove the heat section access panel.
- 5- Turn gas valve switch to **OFF**. See figure 29.
- 6- Wait five (5) minutes to clear out any gas. If you then smell gas, **STOP!** Immediately call your gas supplier from a neighbor's phone. Follow the gas supplier's instructions. If you do not smell gas, go to the next step.
- 7- Turn gas valve switch to **ON**. See figure 29.
- 8- Close or replace the heat section access panel.
- 9- Turn on all electrical power to appliance.

- 10- Set thermostat to desired setting.
- 11- The ignition sequence will start.
- 12- If the appliance does not light the first time (gas line not fully purged), it will attempt up to two more ignitions before locking out.
- 13- If lockout occurs, repeat steps 1 through 10.
- 14- If the appliance will not operate, follow the instructions "Turning Off Gas to Appliance" and call your service technician or gas supplier.

Turning Off Gas to Unit

- 1- If using an electromechanical thermostat, set to the lowest setting.
- 2- Before performing any service, turn off all electrical power to the appliance.
- 3- Open or remove the heat section access panel.
- 4- Turn gas valve switch to **OFF**.
- 5- Close or replace the heat section access panel.

⚠ WARNING	
	Danger of explosion. Can cause injury or death. Do not attempt to light manually. Unit has a direct spark ignition system.

Heating Operation and Adjustments

(Gas Units)

A-Heating Sequence of Operation

- 1- On a heating demand the combustion air inducer starts immediately.
- 2- Combustion air pressure switch proves inducer operation. After a 30-second pre-purge, power is allowed to ignition control. Switch is factory set and requires no adjustment.
- 3- Spark ignitor energizes and gas valve solenoid opens.
- 4- Spark ignites gas, ignition sensor proves the flame and combustion continues.

- 5- If flame is not detected after first ignition trial, ignition control will repeat steps 3 and 4 two more times before locking out the gas valve.
- 6- For troubleshooting purposes, an ignition attempt after lock out may be re-established manually. Move thermostat to "OFF" and return thermostat switch to "HEAT" position.

B-Limit Controls

Limit controls are factory-set and are not adjustable. Two limits are located on the drip shield in the blower compartment. See figure 30.

C-Heating Adjustment

Main burners are factory-set and do not require adjustment.

The following manifold pressures are listed on the gas valve.

- Natural Gas Units - Low Fire - 1.6" w.c. (not adjustable)
- Natural Gas Units - High Fire - 3.7" w.c.
- LP Gas Units - Low Fire - 5.5" w.c. (not adjustable)
- LP Gas Units - High Fire - 10.5" w.c.

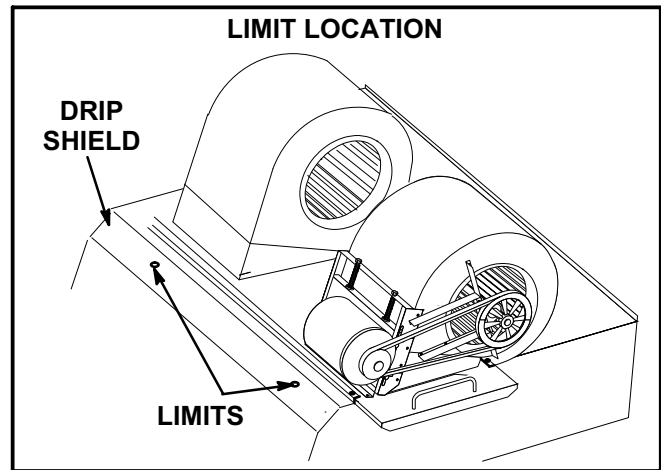

FIGURE 30

Electric Heat Start-Up (LCM Units)

Factory- or Field-Installed Option

Electric heat will stage on and cycle with thermostat demand. Number of stages of electric heat will vary depending on electric heat assembly. See electric heat wiring diagram on unit for sequence of operation.

Variable Air Volume Start-Up

Units contain a supply air blower equipped with a variable frequency drive A96 (VFD) which varies supply air CFM.

The supply air VFD (A96) is located in the control area. See figure 32.

A-Start-Up

- 1- A pressure transducer (A30) is shipped in a box in the blower compartment. Install the transducer according to manufacturer's instructions.

Note - Make sure the transducer is installed in the main duct at least 2/3 of the distance away from the unit.

- 2- Two twisted pairs of shielded cable must be used to connect the pressure transducer. See figure 31. J/P378 connector is hanging in the control box.
- 3- Open all zone dampers and/or boxes.
- 4- Locate the A55 Unit Controller. Refer to figure 32.
- 5- Use the mobile service app to calibrate the blower CFM. Select this menu to start the blower:

SETUP > TEST & BALANCE > BLOWER

The mobile app will display the percent of blower speed. Adjust blower speed percentage to meet design airflow specifications. Allow blower speed to stabilize.

- 6- Press NEXT and follow the instructions to calibrate static pressure. If the static pressure meets the design specification, press NEXT again to set the setpoint. If the static pressure does not meet the design specification, adjust the pressure and press NEXT to set the setpoint.

- 7- Record new setpoints in table 17.

**TABLE 17
RECORD ADJUSTED SETPOINTS**

Parameter	Setpoint Description	Setpoint "w.c.	Display Setting
386	Smoke		
387	Ventilation		
388	Heating		
389	Cooling		

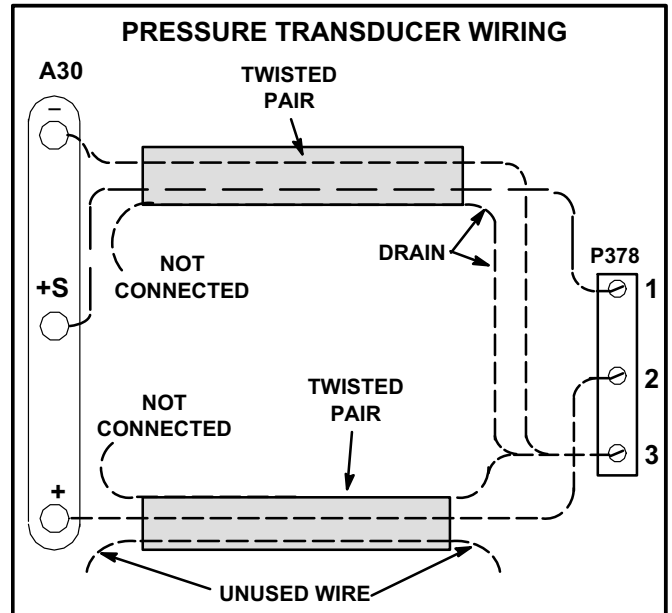

FIGURE 31

Note - The Unit Controller will lock-out the unit for 5 minutes if static pressure exceeds 2.0" w.c. for 20 seconds. The Unit Controller will permanently shut down the unit after three occurrences. See mobile service app parameters 110, 42, and 43 to adjust default values.

- 8- If the desired CFM cannot be met with current pulley setup, refer to the *Blower Operation and Adjustments* section to adjust CFM.

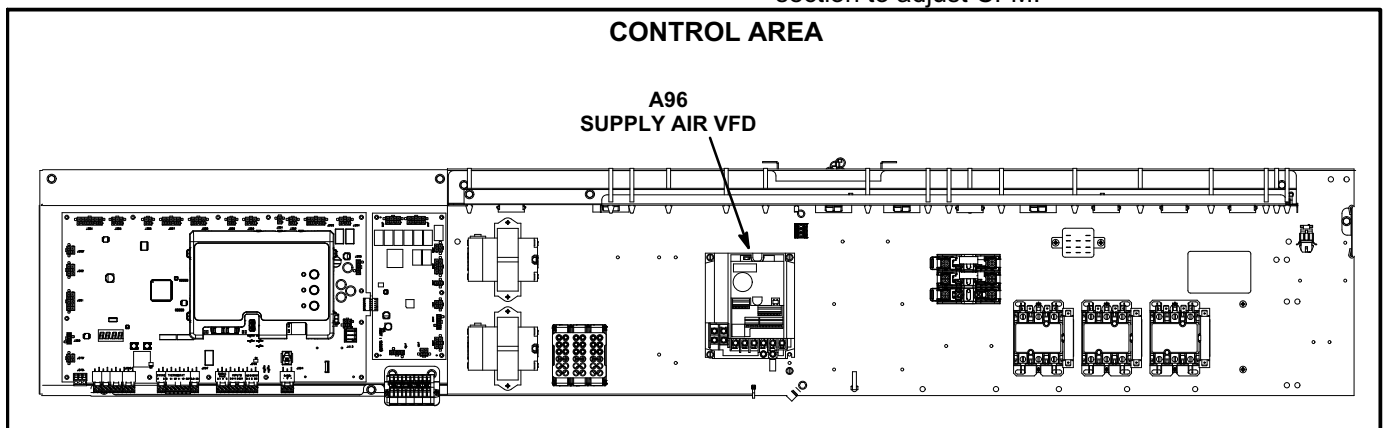

FIGURE 32

B-Unit Operation

Use the mobile app to check unit mechanical operation. See the *Service - Test* section of the Unit Controller manual.

C-Manual Supply Air VFD Bypass

IMPORTANT - All dampers must be open to prevent damage to duct work and dampers.

Note - This section does not apply to units equipped with optional automatic VFD bypass. That option will automatically change from multi-stage air volume to constant air volume operation in the event of VFD failure.

Manually change blower operation to constant air volume as follows:

- 1- Disconnect all power to unit and **WAIT AT LEAST 10 MINUTES** before opening the VFD cover.

⚠ WARNING

ELECTRICAL SHOCK HAZARD.

STOP! Before you continue, make sure that power to the VFD has been off for at least 10 minutes. The capacitor in the VFD holds high voltage power for up to 10 minutes after power has been disconnected.

- 9- Locate P246 and P247 connectors near the VFD. See figure 33.
- 10- Disconnect P246 from P246 (power in to VFD) and P247 from P247 (power out to blower). See figure 34.
- 11- Connect P246 to P247. See figure 35.

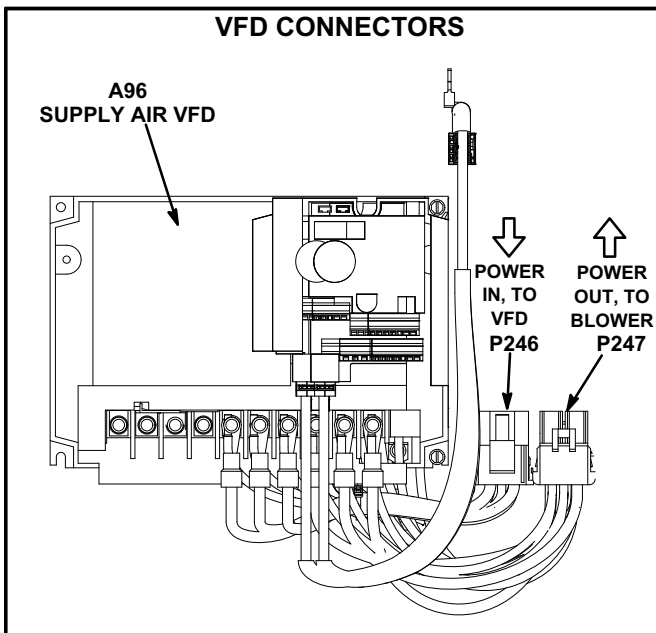

FIGURE 33

- 12- Restore power to unit. Blower will operate in constant air volume (CAV) mode.

Note - The indoor blower motor will start as soon as the main unit power is restored. In manual bypass, the blower will run regardless of thermostat signals until main unit power is turned off. Manual bypass is meant for emergency operation only and not long-term usage.

- 13- Check the indoor blower motor nameplate for full load amperage (FLA) value. Measure the amp readings from the indoor blower motor operating in bypass mode. If measured amps are higher than nameplate FLA value, decrease the CFM by opening (turning counterclockwise) the motor pulley. See figure 15. Do not exceed minimum and maximum number of pulley turns as shown in table 3.

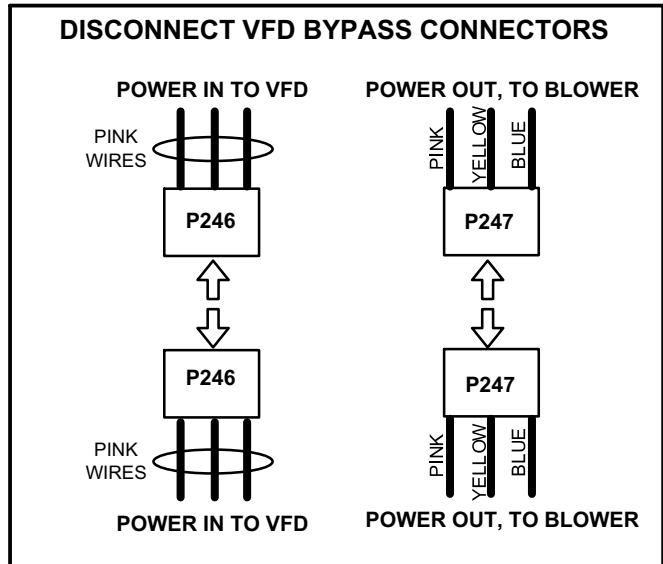

FIGURE 34

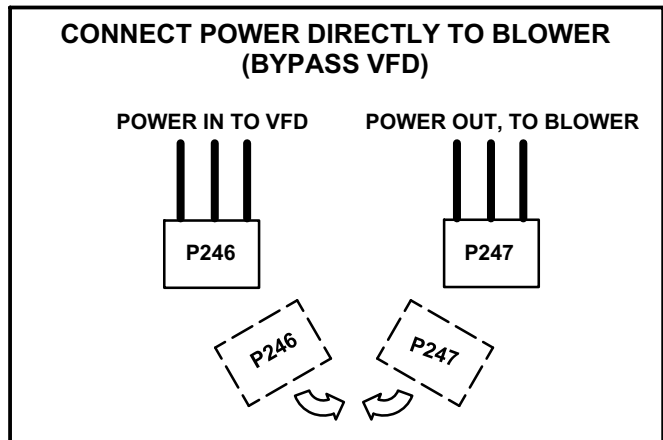

FIGURE 35

Multi-Staged Air Volume Start-Up

A-Design Specifications

Use table 18 to fill in field-provided, design specified blower CFM for appropriate unit.

If only high and low cooling design specifications are provided, set the medium cooling CFM at the high or low cooling design spec or any CFM between.

B-Set Maximum CFM

Use table 18 to determine highest blower CFM for appropriate unit. Adjust the blower pulley to deliver that amount of CFM with only the blower operating. See *Determining Unit CFM* in the Blower Operation and Adjustment section.

C-Set Blower Speeds

- 1- Use the following mobile service app menu to enter the blower design specified CFM into the Unit Controller. Make sure blower CFM is within limitations shown in table 19. Refer to the Unit Controller manual provided with unit.

RTU MENU > RTU OPTIONS > BLOWER > SPEED

- 2- Enter the following design specifications as shown in table 18.

*Blower / Heat CFM
Cooling High CFM
Cooling Low CFM
Vent CFM*

- 3- Adjust the blower RPM to deliver the target CFM based on the measured static pressure using the blower table.
- 4- Measure the static pressure again and apply the static pressure and RPM to the blower tables to determine adjusted CFM.
- 5- Repeat adjustments until design CFM is reached.

D-Set Damper Minimum Position

To maintain required minimum ventilation air volumes when the unit is in the occupied mode, two minimum damper positions must be set.

The Unit Controller will open the damper to "Min OCP Blwr High" when blower CFM is at or ABOVE the "midpoint" CFM.

The Unit Controller will open the dampers to "Min OCP Blwr Low" when blower CFM is BELOW a "midpoint" CFM.

The Unit Controller will calculate the "midpoint" CFM.

**TABLE 18
Blower CFM Design Specifications**

Unit	T'Stat or Zone Control Stages	Blower Speed	Design Specified CFM
156	2	Htg.	
		Clg. High	
		Clg. Low	
		Ventilation	
180	2	Htg.	
		Clg. High	
		Clg. Low	
		Ventilation	
210	2	Htg.	
		Clg. High	
		Clg. Low	
		Ventilation	
240	2	Htg.	
		Clg. High	
		Clg. Low	
		Ventilation	
300	2	Htg.	
		Clg. High	
		Clg. Low	
		Ventilation	

*Available blower speeds vary by unit and thermostat stages.

Set Minimum Position 1

Use the following mobile service app menu to set "Min OCP Blwr High" for the blower CFM above the "midpoint" CFM. When navigating into this menu, the Unit Controller will run damper calibration and allow damper position adjustment.

RTU MENU > SETTINGS > RTU OPTIONS > DAMPER

Tap "Next" to skip tabs and complete damper position calibration until "Damper Calibration Blower Speed High" tab appears.

Measure the intake air CFM. If the CFM is lower than the design specified CFM for ventilation air, use the Unit Controller to increase the damper percent open. If the CFM is higher than specified, decrease the damper percent open.

Note - Intake air CFM can also be determined using the outdoor air temperature, return air temperature and mixed air temperature. Refer to the economizer or outdoor air damper installation instructions.

Set Minimum Position 2

Use the following mobile service app menu in the Unit Controller to set “Min OCP Blwr Low” for the blower CFM below the “midpoint” CFM. When navigating into this menu, the Unit Controller will run damper calibration and allow damper position adjustment.

RTU MENU > SETTINGS > RTU OPTIONS > DAMPER

Tap "Next" to skip tabs and complete damper position calibration until "Damper Calibration Blower Speed High" tab appears.

Measure the intake air CFM. If the CFM is lower than the design specified CFM for ventilation air, use the Unit Controller to increase the damper percent open. If the CFM is higher than specified, decrease the damper percent open.

Note - Intake air CFM can also be determined using the outdoor air temperature, return air temperature and mixed air temperature. Refer to the economizer or outdoor air damper installation instructions.

E-Inverter Bypass Option

The supply air inverter is factory-set to by-pass the inverter manually. To by-pass the inverter and operate the blower in the constant air volume mode, use the following Unit Controller menu and set to “engaged”:

SETTINGS > RTU OPTIONS > BLOWER > VFD
BYPASS

To configure the unit to by-pass the inverter automatically, use the following Unit Controller menu.

SETUP > INSTALL

Press SAVE until the menu reads:

CONFIGURATION ID 1

Change the 6th character position to A for automatic bypass option.

Press SAVE

Caution - Units not equipped with an inverter will have the 6th character set to N, indicating the inverter is not bypassed. The blower motor could be damaged and/or result in product or property damage if the setting is changed to automatic or manual.

**TABLE 19
MINIMUM AND MAXIMUM CFM**

Gas Heat Minimum CFM		
Unit	Gas Heat Size	Airflow CFM
LGM156-300	Low, Std. Med.	4500
LGM156-300	High	5125
Electric Heat Minimum CFM		
Unit	Heat Size (kW)	Airflow CFM
LCM156	All	5200
LCM180-300	All	6000
Cooling Minimum CFM - 220 CFM/ton		
Unit	Blower Speed	Airflow CFM
LGM/LCM156	Low, Med. Low, Med., Med. High	2860
LGM/LCM180	Low, Med. Low, Med., Med. High	3300
LGM/LCM210	Low, Med. Low, Med., Med. High	3850
LGM/LCM240	Low, Med. Low, Med., Med. High	4400
LGM/LCM300	Low, Med. Low, Med., Med. High	5500
Cooling Minimum CFM - 280 CFM/ton		
Unit	Blower Speed	Airflow CFM
LGM/LCM156	High	3640
LGM/LCM180	High	4200
LGM/LCM210	High	4900
LGM/LCM240	High	5600
LGM/LCM300	High	7000
Smoke and Ventilation Minimum CFM - 150 CFM/ton		
Unit	Not Applicable	Airflow CFM
LGM/LCM156	NA	1950
LGM/LCM180	NA	2250
LGM/LCM210	NA	2625
LGM/LCM240	NA	3000
LGM/LCM300	NA	3750
Heating and Cooling Maximum CFM - 480 CFM/ton		
Unit	Blower Speed	Airflow CFM
LGM/LCM156	High	6240
LGM/LCM180	High	7200
LGM/LCM210	High	8400
LGM/LCM240	High	9600
LGM/LCM300	High	12000

Multi-Staged Air Volume Operation

This is a summary of cooling operation. Refer to the sequence of operation provided in the Engineering Handbook or Service Manual for more detail.

Note - During a dehumidification demand the blower operates at the highest speed. Free cooling is locked-out during reheat operation. Refer to reheat start-up and operation section for details.

A-Two-Stage T'Stat / Zone Sensor; 3- and 4-Compressor Units

1-Economizer With Outdoor Air Suitable

Y1 Demand -

Compressors Off
Blower Cooling Low
Dampers modulate

Y2 Demand -

Compressors Off
Blower Cooling High
Dampers Modulate

If dampers are at maximum open for three minutes, compressor 1 and 2 are energized and blower stays on cooling high.

2-No Economizer or Outdoor Air Not Suitable

Y1 Demand -

Compressor 1 (variable speed) On
Remaining compressors are energized
in order to maintain discharge air
temperature (DAT) rises above target
Blower Cooling Low
Dampers Minimum Position

Y2 Demand -

Compressor 1 (variable speed) On
Remaining compressors are energized
in order to maintain discharge air
temperature (DAT) rises above target
Blower Cooling High
Dampers Minimum Position

B-Three-Stage T'Stat / Zone Sensor 3 and 4 Compressor Units AND Zone Sensor (4 Clg. Stages), 3-Compressor Units

1-Economizer With Outdoor Air Suitable

Three-Compressor Units:

Y1 Demand -

Compressors Off
Blower Cooling Low
Dampers Modulate

Y2 Demand -

Compressors Off
Blower Cooling Adjustable from Med to High
Dampers Modulate

Note - If dampers are at maximum open for three minutes, compressor 1 is energized and blower stays on cooling high.

Y3 Demand -

Compressor 1 (variable speed) On
Remaining compressors are energized
in order to maintain discharge air
temperature (DAT) rises above target
Blower Cooling High
Dampers Maximum Open

Four-Compressor Units:

Y1 Demand -

Compressors Off
Blower Cooling Low
Dampers modulate

Y2 Demand -

Compressors Off
Blower Cooling Adjustable from Med to High
Dampers Modulate

If dampers are at maximum open for three minutes, compressors 1 and 2 are energized and blower stays on cooling high.

Y3 Demand -

Compressor 1 (variable speed) On
Remaining compressors are energized
in order to maintain discharge air
temperature (DAT) rises above target
Blower Cooling High
Dampers Maximum Open

2-No Economizer or Outdoor Air Not Suitable

Three- and Four-Compressor Units:

Y1 Demand -

Compressor 1 (variable speed) On
Remaining compressors are energized
in order to maintain discharge air
temperature (DAT) rises above target
Blower Cooling Low

Y2 Demand -

Compressors 1 (variable speed) On
Remaining compressors are energized
in order to maintain discharge air
temperature (DAT) rises above target
Blower Cooling Adjustable from Med to High

Y3 Demand -

Compressors 1 (variable speed) On
Remaining compressors are energized
in order to maintain discharge air
temperature (DAT) rises above target
Blower Cooling High

Hot Gas Reheat Start-Up And Operation

General

Hot gas reheat units provide a dehumidifying mode of operation. These units contain a reheat coil adjacent to and downstream of the evaporator coil. Reheat coil solenoid valves, L14 and L30, route hot discharge gas from the compressor to the reheat coil. Return air pulled across the evaporator coil is cooled and dehumidified; the reheat coil adds heat to supply air.

See figure 36 for 156 and 180 reheat refrigerant routing, figure 37 for 156 and 180 normal cooling refrigerant routing, figure 38 for 210, 240, and 300 reheat refrigerant routing and figure 39 for 210, 240, and 300 normal cooling refrigerant routing.

L14 and L30 Reheat Coil Solenoid Valves

When Unit Controller (P298-5 or J299-8) indicates room conditions require dehumidification, See figure 11 through 13. L14 and L30 reheat valves are energized (Unit Controller J394-1 or J394-3) and refrigerant is routed to the reheat coil.

Reheat Setpoint

Reheat is factory-set to energize when indoor relative humidity rises above 60% (default). The reheat setpoint can be adjusted by changing mobile service app *Settings - Control* menu. A setting of 100% will operate reheat from an energy management system digital output. The reheat setpoint can also be adjusted using an optional Network Control Panel (NCP).

Reheat will terminate when the indoor relative humidity falls 3% (57% default) or the digital output de-energizes. The reheat deadband can be adjusted at *Settings - Control* menu.

A91 Humidity Sensor

Relative humidity should correspond to the sensor (A91) output voltage listed in table 20. For example: if indoor air relative humidity is 80% \pm 3%, the humidity sensor output should read 8.00VDC.

Check the sensor output annually for accuracy. Keep the air intake openings on the sensor clean and free of obstructions and debris.

TABLE 20

Relative Humidity (%RH \pm 3%)	Sensor Output (VDC)
20	2.00
30	3.00
40	4.00
50	5.00
60	6.00
70	7.00
80	8.00
90	9.00

Check-Out

Test hot gas reheat operation using the following procedure.

- 1- Make sure reheat is wired as shown in wiring section.
- 2- Make sure unit is in local thermostat mode.
- 3- Use mobile service app menu path to select:

SERVICE > TEST > DEHUMIDIFIER

The blower, compressor 1 and compressor 2 (reheat) should be operating. Reheat mode will appear on the mobile service app display.

- 4- Deselect:

SERVICE > TEST > DEHUMIDIFIER

Compressor 1 and 2 (reheat) should de-energize, blower should still be energized.

Default Reheat Operation

Reheat will operate as shown in table 21 once this condition is met:

- 1- System must NOT be operating in heating mode.

IMPORTANT - Free cooling does not operate during reheat.

For other reheat control options, refer to the Unit Controller manual.

Additional Cooling Stages

Units are shipped from the factory to provide two stages of cooling.

Compressors are not de-energized when unit operation changes from cooling to reheat or from reheat to cooling. Instead, L14 and L30 reheat valves are energized (reheat) or de-energized (cooling).

NOTE - Another thermostat staging option is available which allows both compressors to be energized during free cooling. See Unit Controller manual for details.

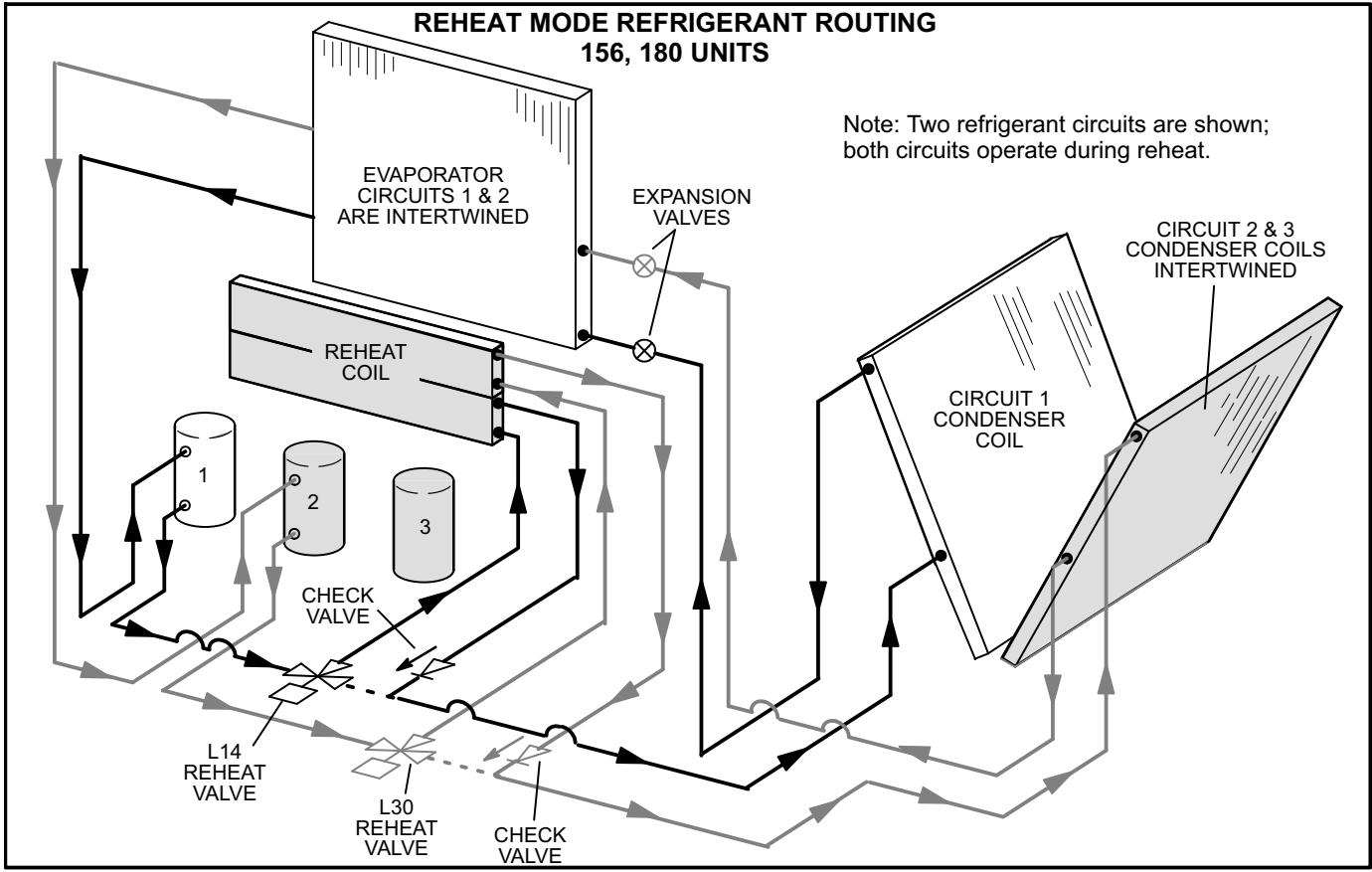

FIGURE 36

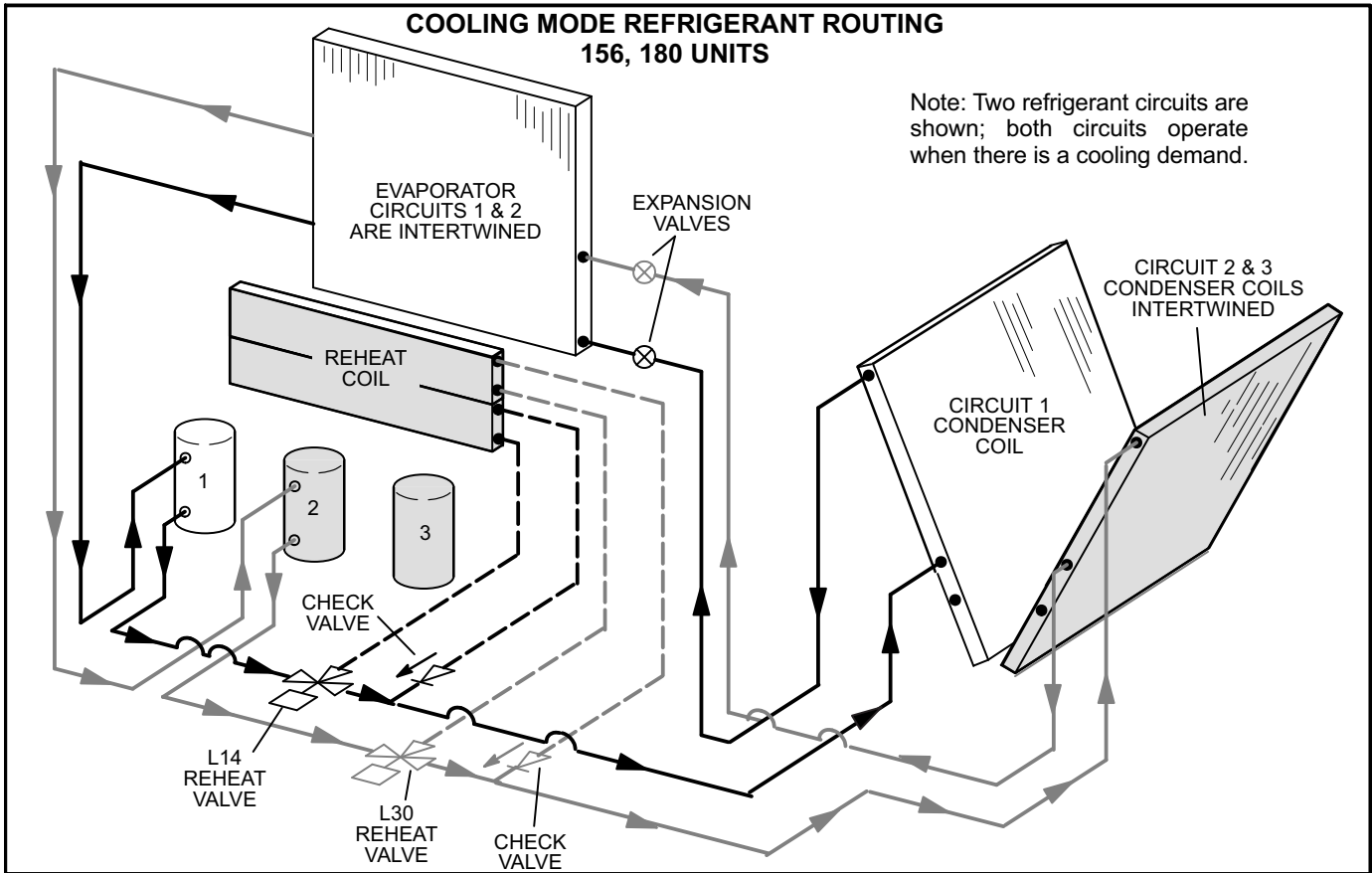

FIGURE 37

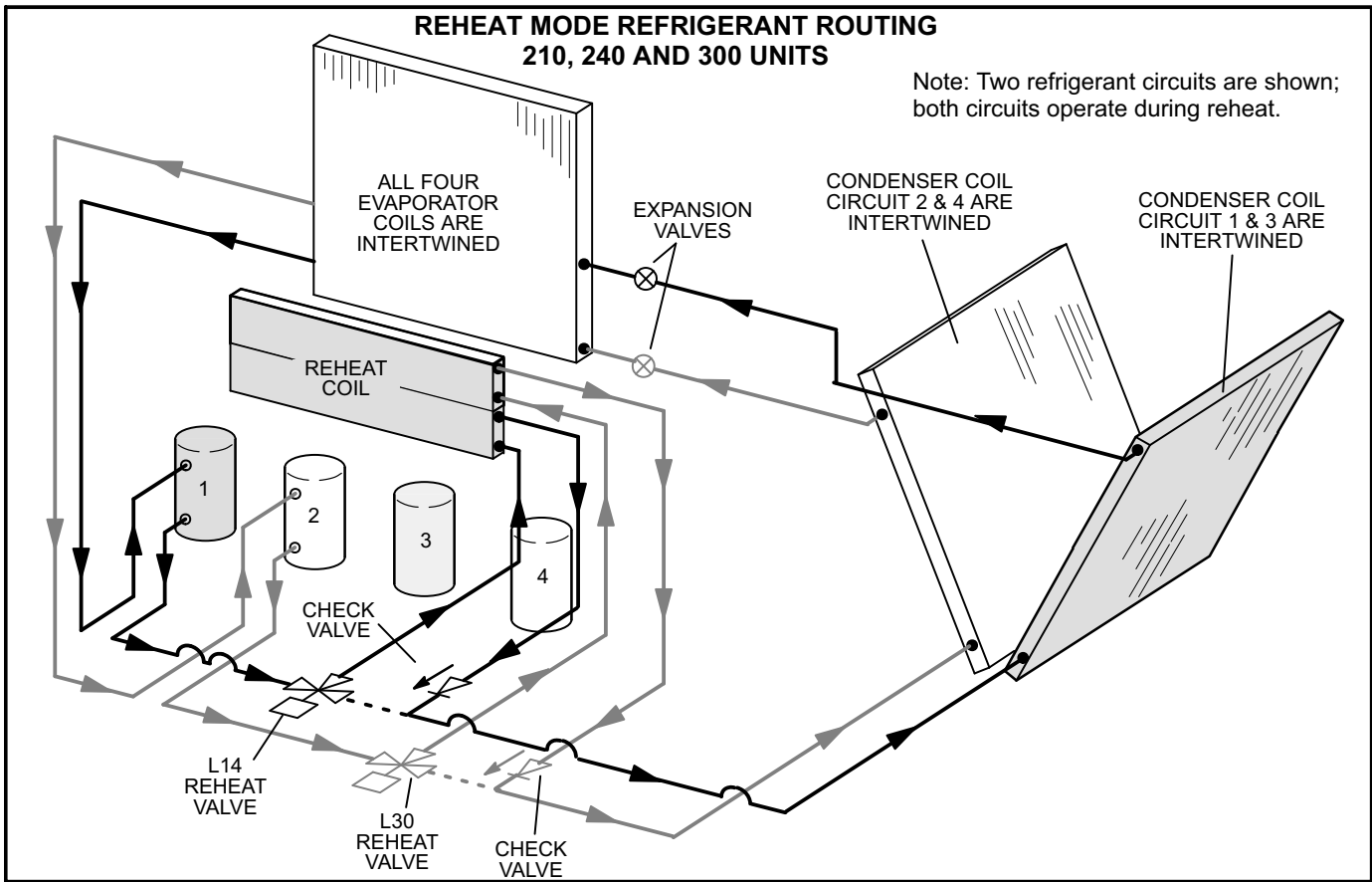

FIGURE 38

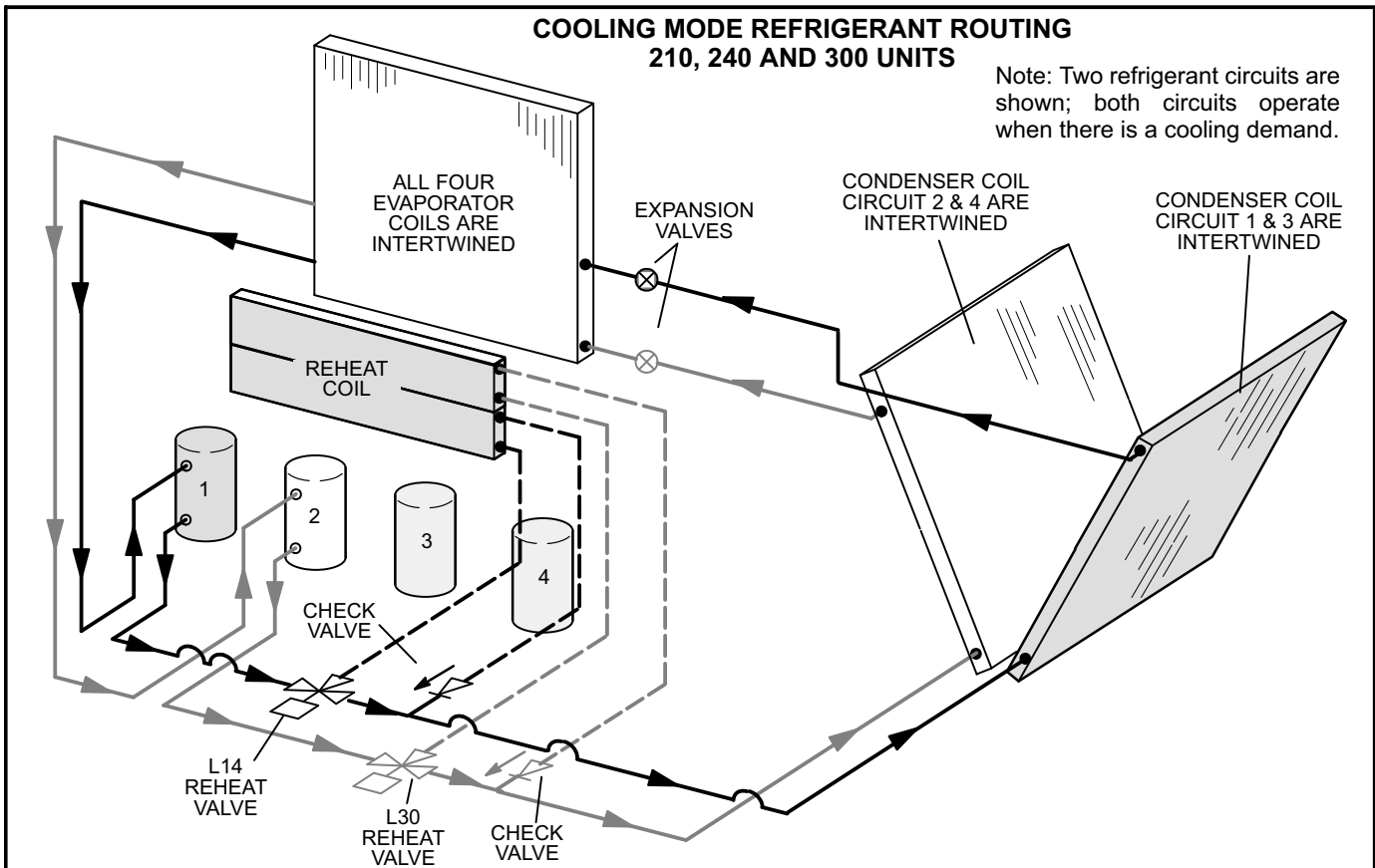

FIGURE 39

**TABLE 21
REHEAT OPERATION**

Thermostat Mode With 24V Humidistat	
Humidity Demands	Operation
24V Demand for Dehumidification only	<ul style="list-style-type: none"> • Compressor 1 reheat on • Compressor 1 operates at 100% • Reheat valve is energized • Remaining compressors are off • Blower and outdoor fans modulate to maintain indoor coil and discharge air temperatures
24V Demand for Dehumidification only is still present after Five Minutes	<ul style="list-style-type: none"> • Compressor 1 & 2 reheat on • Compressor 1 operates at 100% • Reheat valves are energized • Remaining compressor(s) is/are off • Blower and outdoor fans modulate to maintain indoor coil and discharge air temperatures
Thermostat Mode with Zone Relative Humidity (RH) Sensor	
Zone humidity is greater than Setpoint +2%	<ul style="list-style-type: none"> • Compressor 1 reheat on • Compressor 1 modulates to maintain zone RH • Reheat valve is energized • Remaining compressors are off • Blower and outdoor fans modulate to maintain indoor coil and discharge air temperatures
Zone humidity is greater than Setpoint +2% OR Zone humidity is greater than Setpoint for 5 minutes	<ul style="list-style-type: none"> • Compressor 1 & 2 reheat on • Compressor 1 modulates to maintain zone RH • Reheat valves are energized • Remaining compressor(s) is/are off • Blower and outdoor fans modulate to maintain indoor coil and discharge air temperatures

Service

The unit should be inspected once a year by a qualified service technician.

A-Filters

Units are equipped with six 24 X 24 X 2" filters. Filters should be checked monthly and replaced when necessary with filters of like kind and size. Take note of air flow direction marking on filter frame when reinstalling filters. See figure 40.

NOTE-Filters must be U.L.C. certified or equivalent for use in Canada.

B-Lubrication

All motors are lubricated at the factory. No further lubrication is required.

Blower shaft bearings are prelubricated. For extended bearing life, relubricate at least once every two years with a lithium base grease, such as Alvania 3 (Shell Oil), Chevron BRB2 (Standard Oil) or Regal AFB2 (Texas Oil). Use a hand grease gun for relubrication. Add only enough grease to purge through the bearings so that a bead of grease appears at the seal lip contacts.

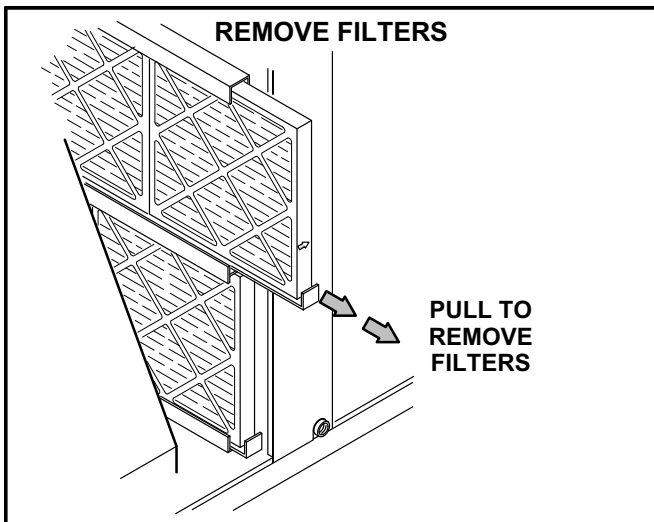

FIGURE 40

CAUTION

Label all wires prior to disconnection when servicing controls. Wiring errors can cause improper and dangerous operation. Verify proper operation after servicing.

C-Burners (Gas Units)

Periodically examine burner flames for proper appearance during the heating season. Before each heating season examine the burners for any deposits or blockage which may have occurred.

Clean burners as follows:

- 1- Turn off both electrical power and gas supply to unit.
- 2- Open burner compartment access panel.
- 3- Remove screws securing burner assembly to burner support and remove assembly. See figure 41. Clean as necessary.
- 4- Locate the ignitor under the left burners. Check ignitor spark gap with appropriately sized twist drills or feeler gauges. See figure 42.
- 5- Check the alignment of the ignitor and the sensor as shown in figure 43 and table 22.
- 6- Replace burners and screws securing burner.
- 7- Replace access panel.
- 8- Restore electrical power and gas supply. Follow lighting instructions attached to unit and use inspection port in access panel to check flame.

WARNING



Danger of explosion. Can cause injury or death. Do not overtighten main burner mounting screws. Snug tighten only.

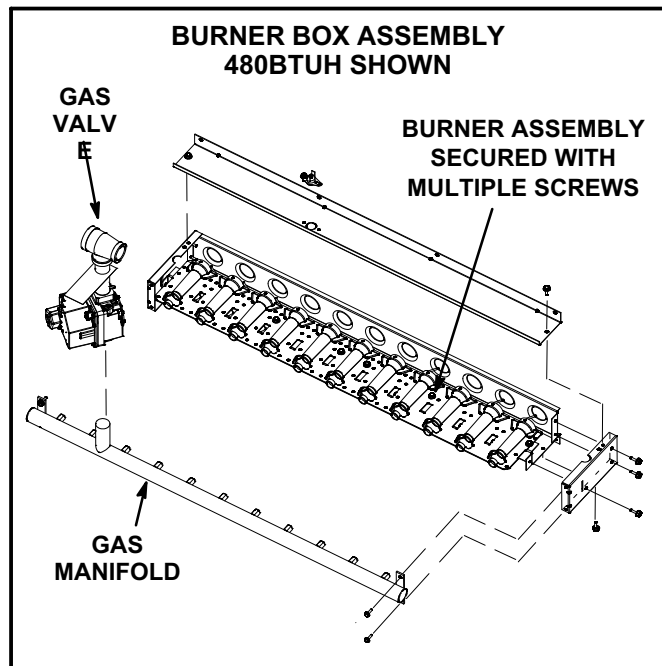

FIGURE 41

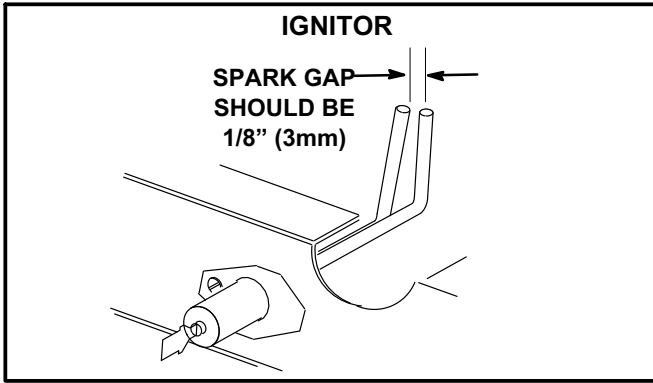

FIGURE 42

TABLE 22

Dimension	Unit Btuh Input	Length - in. (mm)	
		Ignitor	Sensor
A	260K	7-3/4 (197)	11 (279)
B	360K	5 (127)	5-1/2 (140)
C	480K	2-1/4 (57)	2-3/4 (70)

D-Combustion Air Inducer (Gas Units)

A combustion air proving switch checks combustion air inducer operation before allowing power to the gas controller. Gas controller will not operate if inducer is obstructed.

Under normal operating conditions, the combustion air inducer wheel should be checked and cleaned prior to the heating season. However, it should be examined periodically during the heating season to establish an ideal cleaning schedule. With power supply disconnected, the condition of the inducer wheel can be determined by looking through the vent opening.

Clean combustion air inducer as follows:

- 1- Shut off power supply and gas to unit.
- 2- Disconnect pressure switch air tubing from combustion air inducer port.
- 3- Remove and retain screws securing combustion air inducer to flue box. Remove and retain two screws from bracket supporting vent connector. See figure 44.
- 4- Clean inducer wheel blades with a small brush and wipe off any dust from housing. Clean accumulated dust from front of flue box cover.
- 5- Return combustion air inducer motor and vent connector to original location and secure with retained screws. It is recommended that the combustion air inducer gasket be replaced during reassembly.
- 6- Clean combustion air inlet louvers on heat access panel using a small brush.

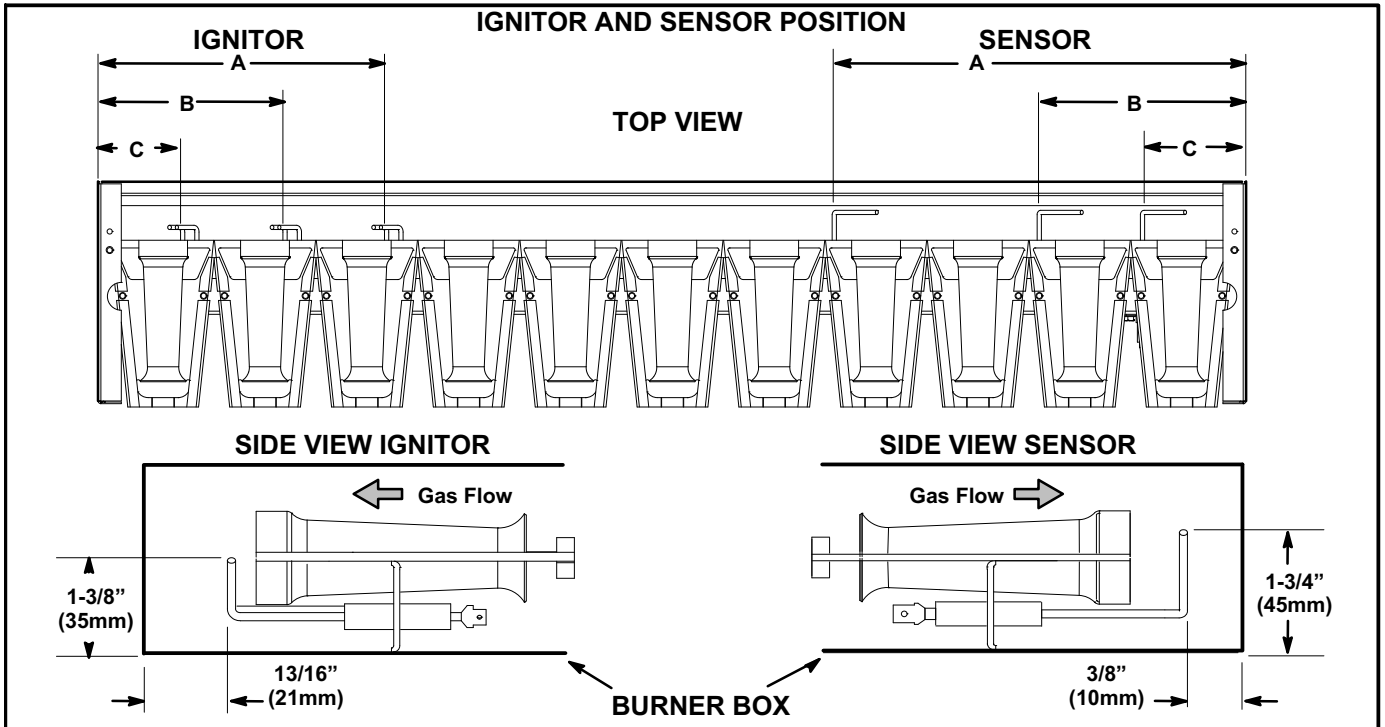

FIGURE 43

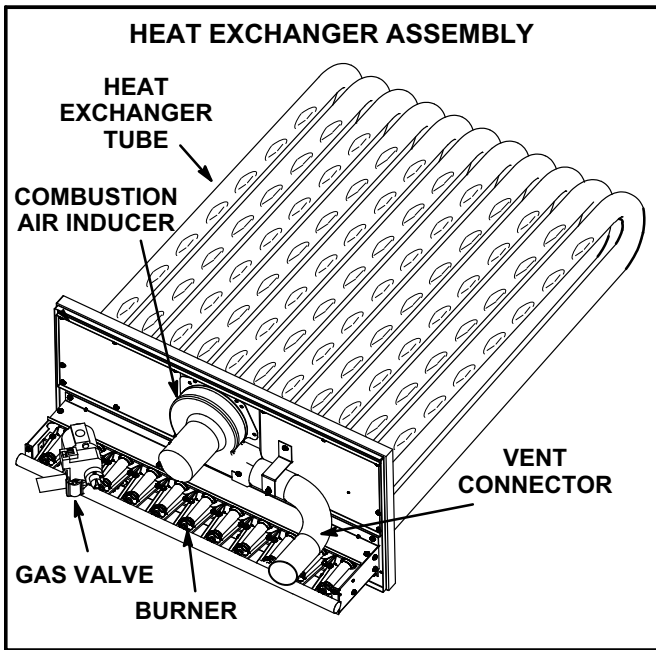

FIGURE 44

E-Flue Passageway and Flue Box (Gas Units)

- 1- Remove combustion air inducer assembly as described in section D.
- 2- Remove flue box cover. Clean with a wire brush as required.
- 3- Clean tubes with a wire brush.
- 4- Reassemble the unit. The flue box cover gasket and combustion air inducer gasket should also be replaced during reassembly.

F-Evaporator Coil

Inspect and clean coil at beginning of each cooling season. Clean using mild detergent or commercial coil cleaner. Flush coil and condensate drain with water taking care not to get insulation, filters and return air ducts wet.

G-Supply Air Blower Wheel

Annually inspect supply air blower wheel for accumulated dirt or dust. Turn off power before attempting to remove access panel or to clean blower wheel.

H-Condenser Coil

Clean condenser coil annually with detergent or commercial coil cleaner and inspect monthly during the cooling season. Access panels are provided on front and back of condenser section.

J-Needlepoint Bipolar Ionizer

The optional, brush-type ionizer produces positive and negative ions to clean air and reduce airborne contaminants. The ionizer was designed to be low maintenance. The device should be checked semi-annually to confirm the brushes are clean for maximum output. The ionizer is located behind the filters. See figure 45.

- 1- Remove filters, screws securing the top and bottom of the upper filter bracket, and the wire ties the screws hold in place. See figure 45.
- 2- Disconnect the ionizer plug near the top of the filter rack.
- 3- Pull ionizer out of unit and clean brushes.
- 4- Replace ionizer, reconnect ionizer plug, and replace filters, screws, and wire ties.

INSTALL IONIZER - 156-300

20 TON SHOWN
(5 IONIZERS)

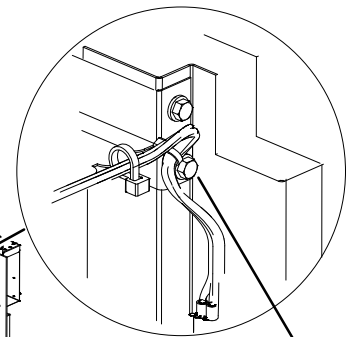

REMOVE THE SCREW
SECURING THE **TOP**
OF THE UPPER FILTER
RACK BRACKET

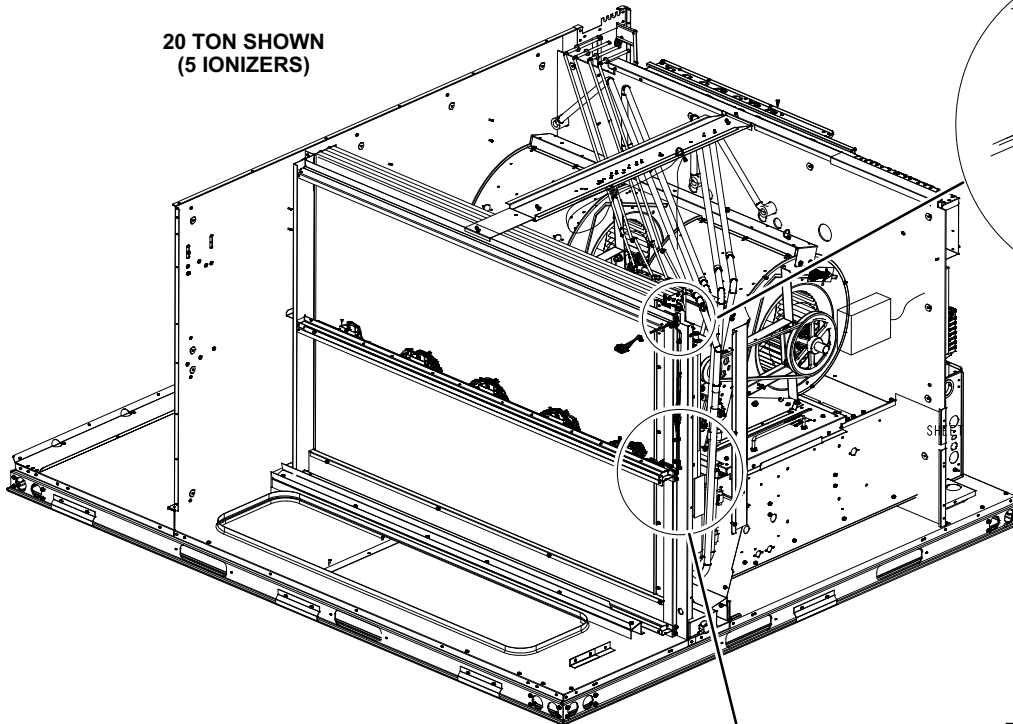

**ONE EDGE
PROTECTOR ON
IONIZER BRACKET**

EVAPORATOR
COIL

**TWO EDGE
PROTECTORS ON
FILTER RACK**

REMOVE THE
SCREW SECURING
THE **BOTTOM** OF
THE UPPER FILTER
RACK BRACKET

IONIZER
BRACKET

UPPER FILTER
BRACKET
U-CHANNEL

SLIDE IONIZER BRACKET
BETWEEN UPPER AND LOWER
FILTER BRACKET U-CHANNELS

LOWER FILTER
BRACKET
U-CHANNEL

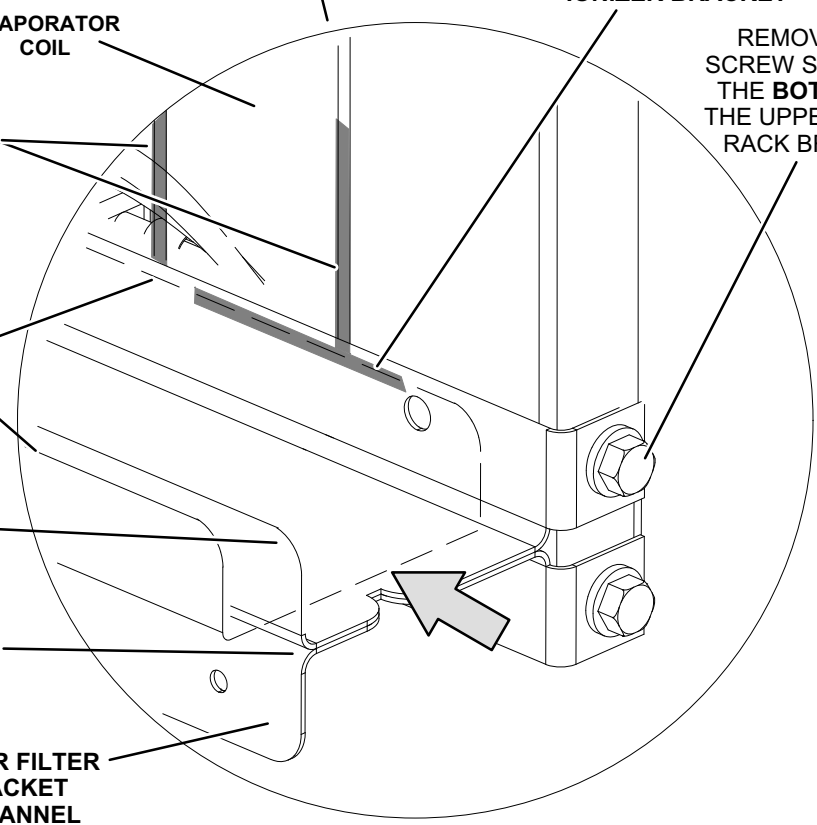

FIGURE 45

K-UVC Light (Optional)

Factory-Installed UVC Light

When the UVC light is factory installed, the lamp is shipped in a foam sleeve. The lamp is attached to the UVC light assembly on the blower deck. Remove the lamp and install into the UVC light assembly as shown in steps 2 through 11 as follows.

Annual Lamp Replacement

⚠️ WARNING

Personal Burn Hazard.

Personal injury may result from hot lamps. During replacement, allow lamp to cool for 10 minutes before removing lamp from fixture.

The lamp should be replaced every 12 months, as UVC energy production diminishes over time.

- 1- Obtain the correct model germicidal light replacement lamp.
- 2- Disconnect power to the rooftop unit before servicing the UVC kit.
- 3- Open the blower access door.
- 4- Disconnect the UVC cable quick connects (black/white).
- 5- Remove and retain the (3) mounting screws securing the UVC assembly. Carefully remove the complete UVC assembly out through the blower access door. See figure 47.

6- Allow 10 minutes before touching the lamps. Then, carefully remove the lamp splash guards (and lamp for annual replacement) from each of the lamp holders. See figure 46.

7- Wear cotton gloves or use a cotton cloth when handling the new lamp. Gently but firmly push in the splash guards on each end of the lamp. Align and insert the lamp with splash guard into the lamp holders of the UVC assembly until each end clicks into place.

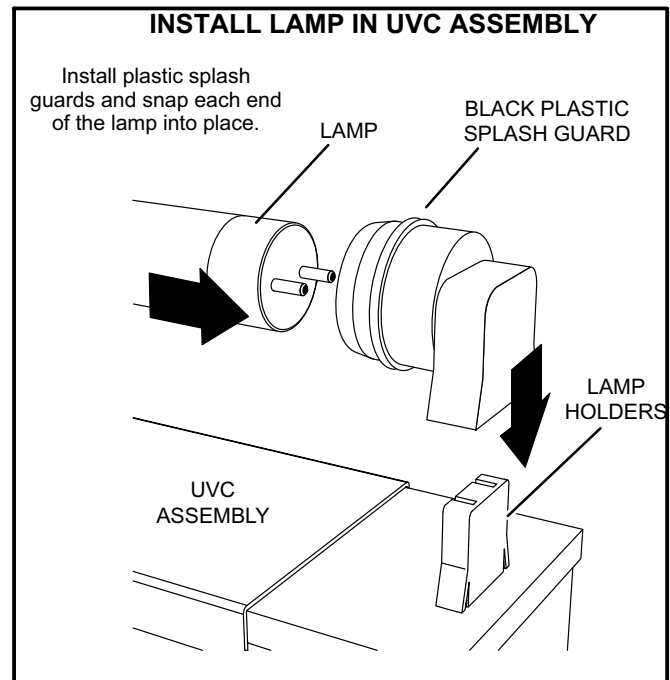

FIGURE 46

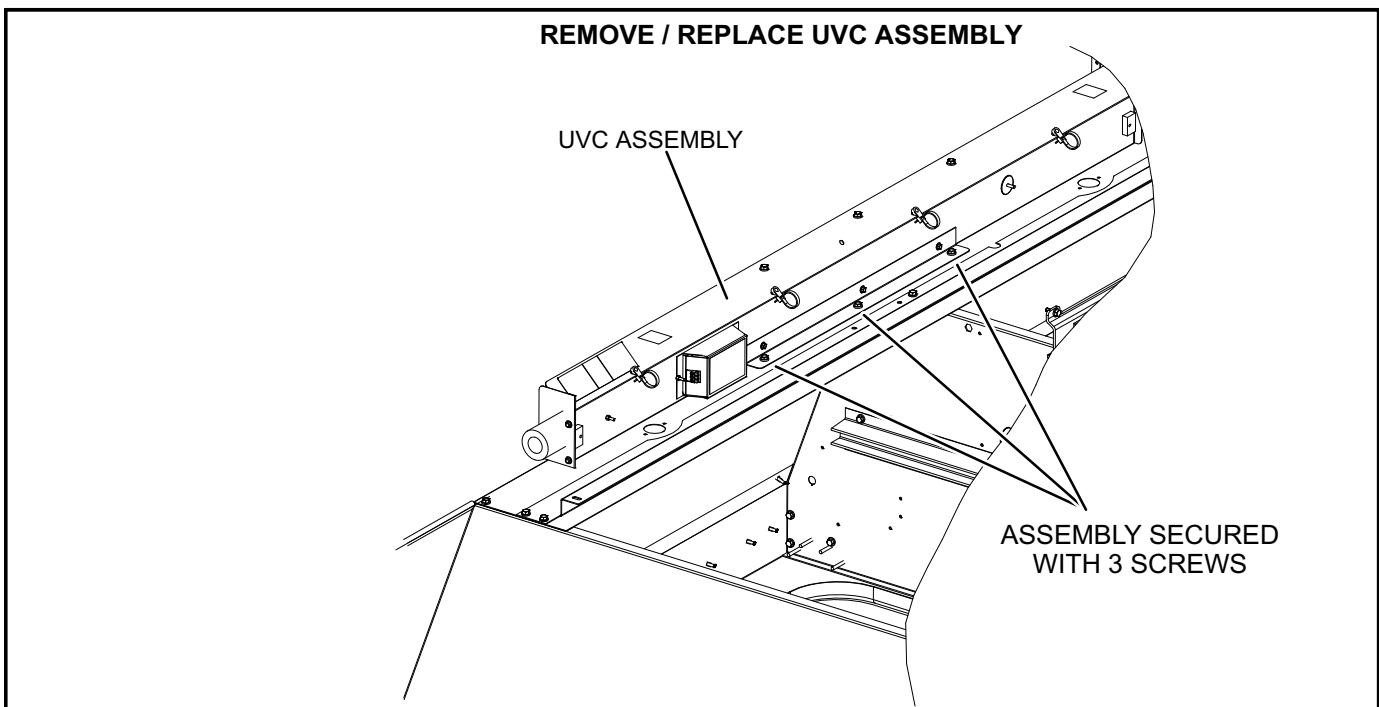

FIGURE 47

- 8- Carefully place the UVC assembly on the blower deck. Line up the mounting holes on the UVC assembly with the mounting holes on the blower deck. Use the retained #10 screws to attach the UVC assembly in place.
- 9- Close the blower access door.
- 10- Reconnect power to the rooftop unit.
- 11- Open the filter access door and look through the view port in the triangular sheet-metal panel to verify that the UVC light is on.

For all maintenance, contact a licensed HVAC technician.

If UVC lamp does not come on:

- 1- Check Power Wiring: Disconnect 1/4" QC (quick connects) of the UVC cable near the UVC assembly. With Power ON, use multimeter to test 110-230V at the 1/4"QC quick connects from the control panel.
- 2- Check Lamp: Carefully remove the UVC assembly out of the rooftop unit. Use multimeter to test for continuity across each pair of pins at each end of the lamp.
- 3- Check Lamp Installation: Make sure that lamp's pins snap properly into the lamp holder.

Lamp Disposal

Hg-Lamp Contains Mercury - Manage in accordance with local, state and federal disposal laws. Refer to www.lamprecycle.org.

Proper Clean-up Technique in Case of Lamp Breakage
Wear protective gloves, eye wear and mask.

Sweep the broken glass and debris into a plastic bag, seal the bag, and dispose of properly. Contact your local waste management office for proper disposal.

Do not use a vacuum cleaner. Do not incinerate.

Factory Unit Controller Settings

Use the mobile service app to adjust parameters; menu paths are shown in each table. Refer to the Unit Controller manual provided with each unit.

Tables 23 through 27 show factory settings (in degrees, % of fan CFM, etc.). Record adjusted settings on the label located inside the compressor access panel.

When field installing optional kits and accessories, the Unit Controller must be configured to identify the option before it will function. Refer to figures 48 and 49 to determine whether the Unit Controller configuration I.D. must change. To configure the option, use MAIN MENU > SETUP > INSTALL menu path. Press SAVE until CONFIGURATION ID 1 or 2 appears depending on the option installed. Change the appropriate character in the configuration I.D. For example, when an economizer is installed using a single enthalpy sensor, change configuration I.D. 1, the second character, to "S".

TABLE 23 - 581038-01

Units With BACnet Module Settings	
RTU Menu > Network Integration > Network Setup Wizard > BACnet MS/TP > See BACnet MAC Address	
BACNET MAC ADDRESS:	
Units With Room Sensor, CPC/LSE Gateway Settings	
RTU Menu > Network Integration > Network Setup Wizard > SBUS > Set SBUS Address	
LCONN ADDRESS:	

TABLE 24 - 581024-01

Units With Hot Gas Reheat			
RTU Menu > Settings "RTU Options" > Dehumidifier			
Parameter	Factory Setting	Field Setting	Description
105	7		Factory Setting 7: Reheat mode enabled without prerequisite conditions. Controlled by RH sensor (A91) connected to input A55_P298_5 and set point set at parameter 106 (default 60%).

TABLE 25 581037-01

Units With LonTalk Settings	
Use menu RTU Menu > Network Integration > Network Setup Wizard > Set "LONTALK"	

TABLE 26 - 581025-01

LGM/LCM 156U, 180U, 210U, 240U, 300U Staged							
Para meter	Factory Setting					Field Setting	Description
	156U	180U	210U	240U	300U		
Note: Any changes to Smoke CFM setting must be adjusted before the other CFM settings. Use SETTINGS > RTU OPTIONS > EDIT PARAMETERS							
12	5200 CFM	6000 CFM	7000 CFM	8000 CFM	10000 CFM	CFM	Blower CFM during smoke detection.
SETUP > TEST & BALANCE (can also use SETTINGS > RTU OPTIONS > BLOWER > SPEEDS)							
17	1150 CFM	1325 CFM	1550 CFM	1750 CFM	2200 CFM	CFM	Blower CFM during COOLING LOW operation.
14	4550 CFM	5250 CFM	6125 CFM	7000 CFM	8750 CFM	CFM	Blower CFM during COOLING HIGH operation.
13	5200 CFM	6000 CFM	7000 CFM	8000 CFM	10000 CFM	CFM	Blower CFM during Heating operation.
18	1150 CFM	1325 CFM	1550 CFM	1750 CFM	2200 CFM	CFM	Blower CFM during ventilation.
SETUP > TEST & BALANCE (can also use SETTINGS > RTU OPTIONS > DAMPER)							
9	0%	0%	0%	0%	0%	%	Damper min. position during LOW blower operation.
132	0%	0%	0%	0%	0%	%	Damper min. position during HIGH blower operation.
215	50%	50%	50%	50%	50%	%	Min. damper % for stg 1 power exhaust operation.
SETTINGS > RTU OPTIONS > EDIT PARAMETERS							
29	101%	101%	101%	101%	101%	%Open	Damper minimum position during G blower operation. (Setting parameter 29 to "101" disables parameter 29 and passes control to parameter 9 or 132)
219	75%	75%	75%	75%	75%	%	Min. damper % for stg 2 power exhaust operation.
216	10%	10%	10%	10%	10%	%	Deadband % for stage 1 power exhaust operation.
220	10%	10%	10%	10%	10%	%	Deadband % for stage 2 power exhaust operation.
224	100	100	100	100	100	Sec	Stage 1 power exhaust off-delay in seconds.
30	70%	70%	70%	70%	70%	%Speed	Minimum blower speed % for stage 2 power exhaust operation.

TABLE 27 - 581026-01

LGM/LCM 156-300U - VAV - Test and Balance Settings			
Para-meter	Factory Setting	Field Setting	Description
Use SETTINGS > RTU OPTIONS > EDIT PARAMETERS			
386	1	W.C.	Supply static pressure setpoint during smoke operation.
SETUP > TEST & BALANCE > (can also use SETTINGS > RTU OPTIONS > BLOWER > SPEEDS)			
	1	W.C.	Supply static pressure setpoint
SETUP > TEST & BALANCE (can also use SETTINGS > RTU OPTIONS > DAMPER) (Optional)			
132	0%	%	Damper min. position during blower operation.
215	50%	%	Min. damper % for stage 1 power exhaust operation.
219	75%	%	Min. damper % for stage 2 power exhaust operation.
217	0.05	W.C.	Pressure setpoint for stage 1 power exhaust operation.
221	0.10	W.C.	Pressure setpoint for stage 2 power exhaust operation.
29	101%	%Open	Damper minimum position during G blower operation. (Setting parameter 29 to "101" disables parameter 29 and passes control to parameter 9 or 132)

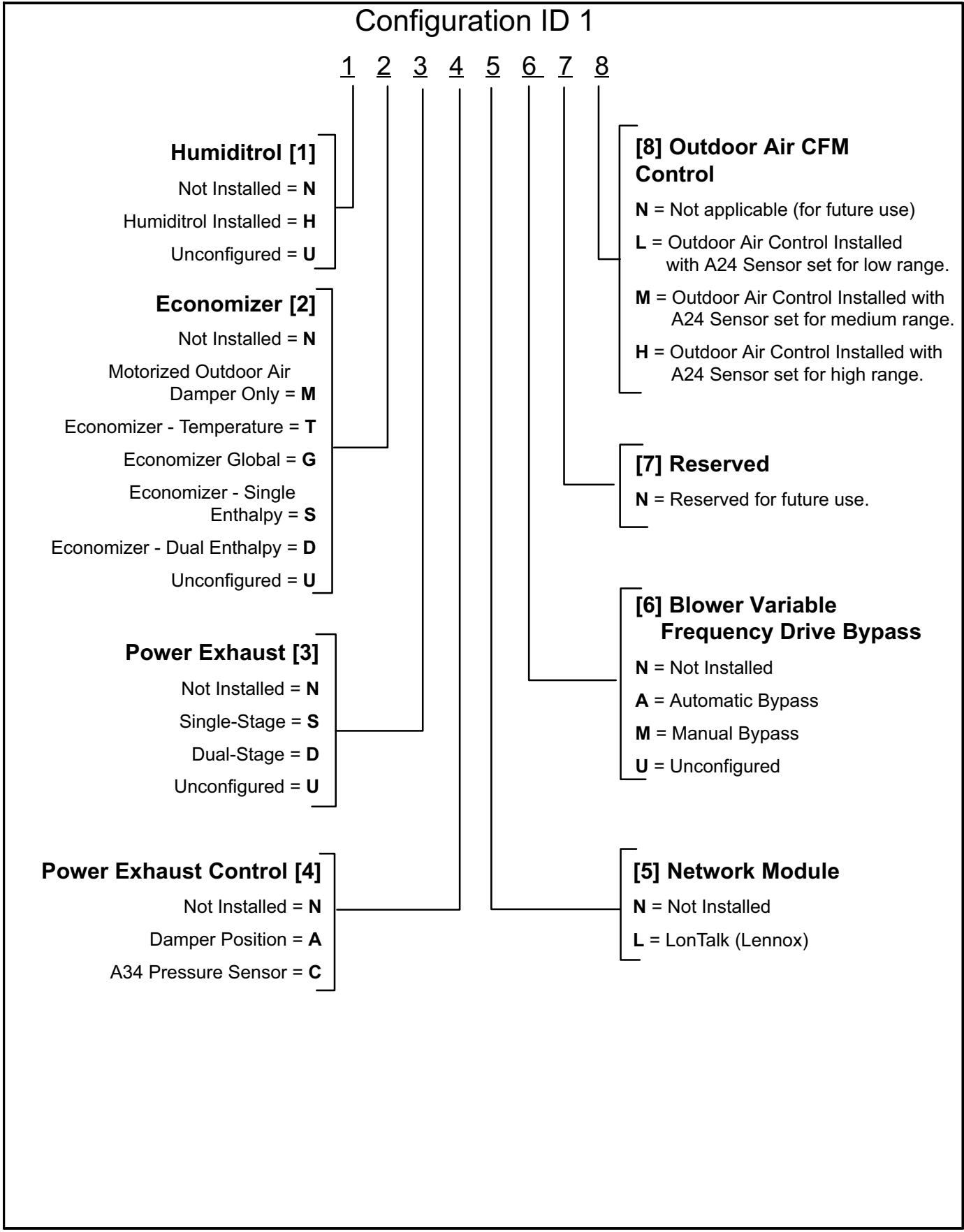
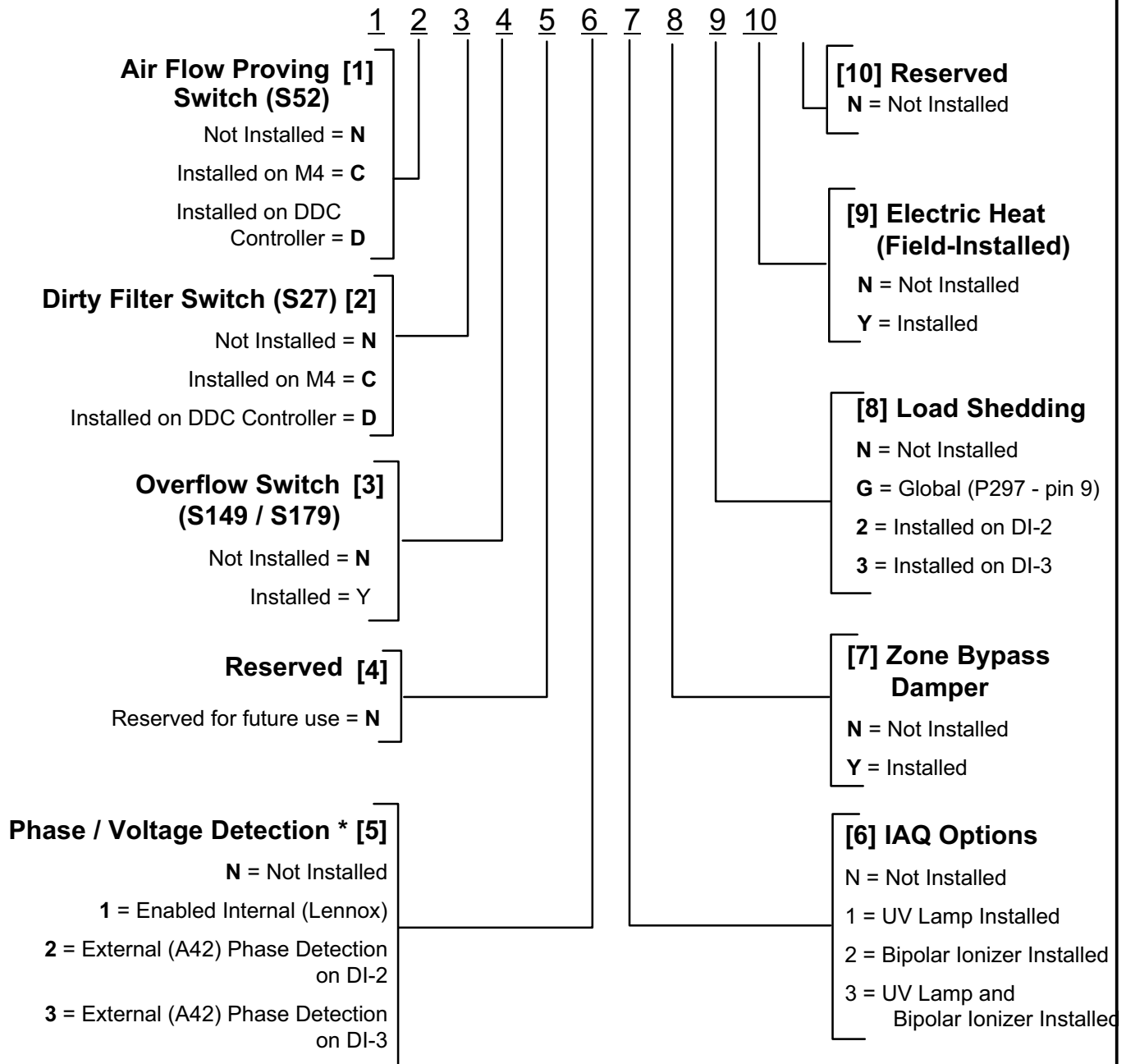

FIGURE 48

Configuration ID 2



* When phase detection and voltage monitoring is enabled and wired incorrectly, the system will go into demand hold status and restart after six minutes.

FIGURE 49

START-UP REPORT

Job Name: _____
 Store No. _____ Start-Up Date: _____
 Address: _____
 City: _____ State: _____
 Start-Up Contractor: _____
 Technician: _____
 Model No.: _____
 Serial No.: _____
 RTU No.: _____ Catalog No.: _____

Inspections and Checks			
Damage?	Yes	No	R22 <input type="checkbox"/> R410A <input type="checkbox"/>
If yes, reported to: _____			
Verify factory and field-installed accessories.			
Check electrical connections. Tighten if necessary.			
Supply voltage: L1-L2 _____ L1-L3 _____ L2-L3 _____			
If unit contains a 208-230/240 volt transformer:			
Check primary transformer tap <input type="checkbox"/>			
Transformer secondary voltage: _____			

Cooling Checks												
Compressor Rotation <input type="checkbox"/> Ambient Temp. _____ Return Air Temp. _____ Supply Air Temp. _____												
	Compressor Amps			Compressor Volts			Pressures		Condenser Fan Amps			CC Heater Amps
	L1	L2	L3	L1-L2	L1-L3	L2-L3	Disch.	Suct.	L1	L2	L3	L1
1												
2												
3												
4												

Blower Checks	
Pulley/Belt Alignment <input type="checkbox"/>	Blower Rotation <input type="checkbox"/>
Set Screws Tight <input type="checkbox"/>	Belt Tension <input type="checkbox"/>
Nameplate Amps: _____ Volts: _____	
Motor	Amps
	Volts
L1 _____	L1-L2 _____
L2 _____	L1-L3 _____
L3 _____	L2-L3 _____

Heating Checks - Electric							
Return Air Temp.: _____ Supply Air Temp.: _____							
Limits Operate: <input type="checkbox"/>							
	Amps						
	L1	L2	L3		L1	L2	L3
1				10			
2				11			
3				12			
4				13			
5				14			
6				15			
7				16			
8				17			
9				18			

Heating Checks - Gas		
Fuel type: Nat. <input type="checkbox"/> LP <input type="checkbox"/> Inlet Pressure: _____ in. w.c.		
Return Air Temp.: _____ Supply Air Temp.: _____		
Altitude: _____ Primary Limits Operate: <input type="checkbox"/>		
Gas Valve	Manifold Pressure	
	Low Fire	High Fire
GV1		
GV2		

Control Type

Accessory Checks	
Power Exhaust Amps	
1 _____	2 _____ None <input type="checkbox"/>
Economizer Operation	
Min. Pos. <input type="checkbox"/>	Motor travel full open/close <input type="checkbox"/>