

# PACKAGED UNITS - KITS

508119-01  
4/2021

## BLOWER ASSEMBLY REPLACEMENT KIT

### INSTALLATION INSTRUCTIONS FOR BLOWER ASSEMBLY REPLACEMENT KIT USED WITH LGM/LCM036-074 UNITS

#### Shipping and Packing List

Package 1 of 1 contains:

- 1- Blower assembly

### ⚠ WARNING

Improper installation, adjustment, alteration, service or maintenance can cause property damage, personal injury or loss of life. Installation and service must be performed by a licensed professional HVAC installer or equivalent, service agency, or the gas supplier

#### Application

The blower assembly replacement kit is used on LGM/LCM036 - 074 units. See table 1.

TABLE 1

Cat. No.	Assembly No.	Voltage
21P12	621654-01	Y
21P13	621654-02	G, J
21P15*	621654-03	Y
21P17*	621654-04	G, J

\*Corrosion protection

#### Installation

- 1- Disconnect electrical power to unit. Wait five minutes before continuing service procedures to avoid electrical shock. This will allow internal capacitors time to fully discharge.
- 2- Open access panels as shown in figure 1.
- 3- Disconnect J48 from P48 in the blower area and unscrew the GND terminal from the blower deck.
- 4- Disconnect the Modbus 9-pin blower control plug located in the blower area.
- 5- Remove four screws securing blower assembly to unit. See figure 2.
- 6- If unit was equipped with a blower proving switch, remove switch from existing blower housing. Attach the proving switch to replacement housing in the same manner it was removed.

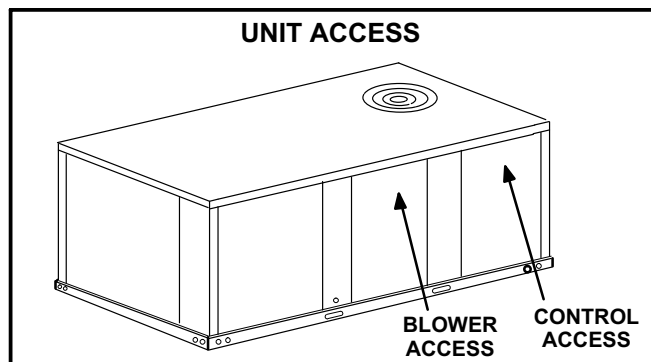

FIGURE 1

### ⚠ CAUTION

As with any mechanical equipment, contact with sharp sheet metal edges can result in personal injury. Take care while handling this equipment and wear gloves and protective clothing.

- 7- Remove PT6 pressure transducer bracket and silicone tubing from housing. See figure 2. If needed, remove the inlet ring to disconnect the tubing from the inlet ring barb. See figure 3. Disconnect the pressure transducer wire connector.
- 8- Use the handle on the blower assembly to slide the assembly out of unit.
- 9- Attach the pressure transducer bracket, wire connector, and silicone tubing to the replacement housing in reverse order of removal.
- 10- Install replacement blower assembly flanges into rails on the blower deck in the same manner it was removed. Secure into place using four screws shown in figure 2.
- 11- Uncoil P48 and Modbus 9-pin blower control wiring harnesses secured to replacement blower housing. See figure 4.
- 12- Connect P48 to J48 in blower compartment. Screw GND terminal to blower deck in the same manner it was removed.
- 13- Connect the Modbus plug in the blower area to the replacement blower motor 9-pin control plug.
- 14- Bundle harnesses and use wire ties to secure kit harnesses to unit harnesses in the same manner they were removed.

**SLIDE BLOWER ASSEMBLY OUT OF UNIT**

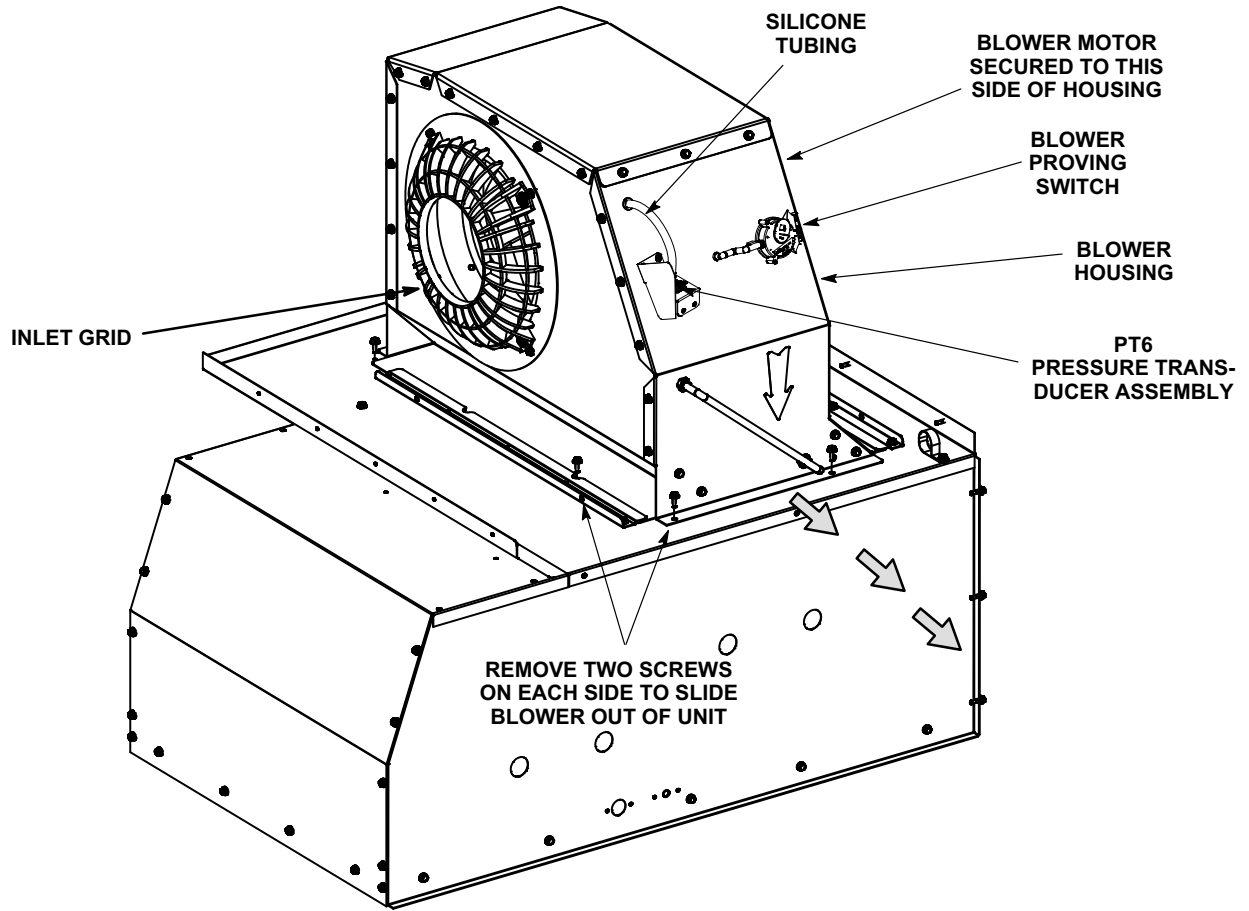

**FIGURE 2**

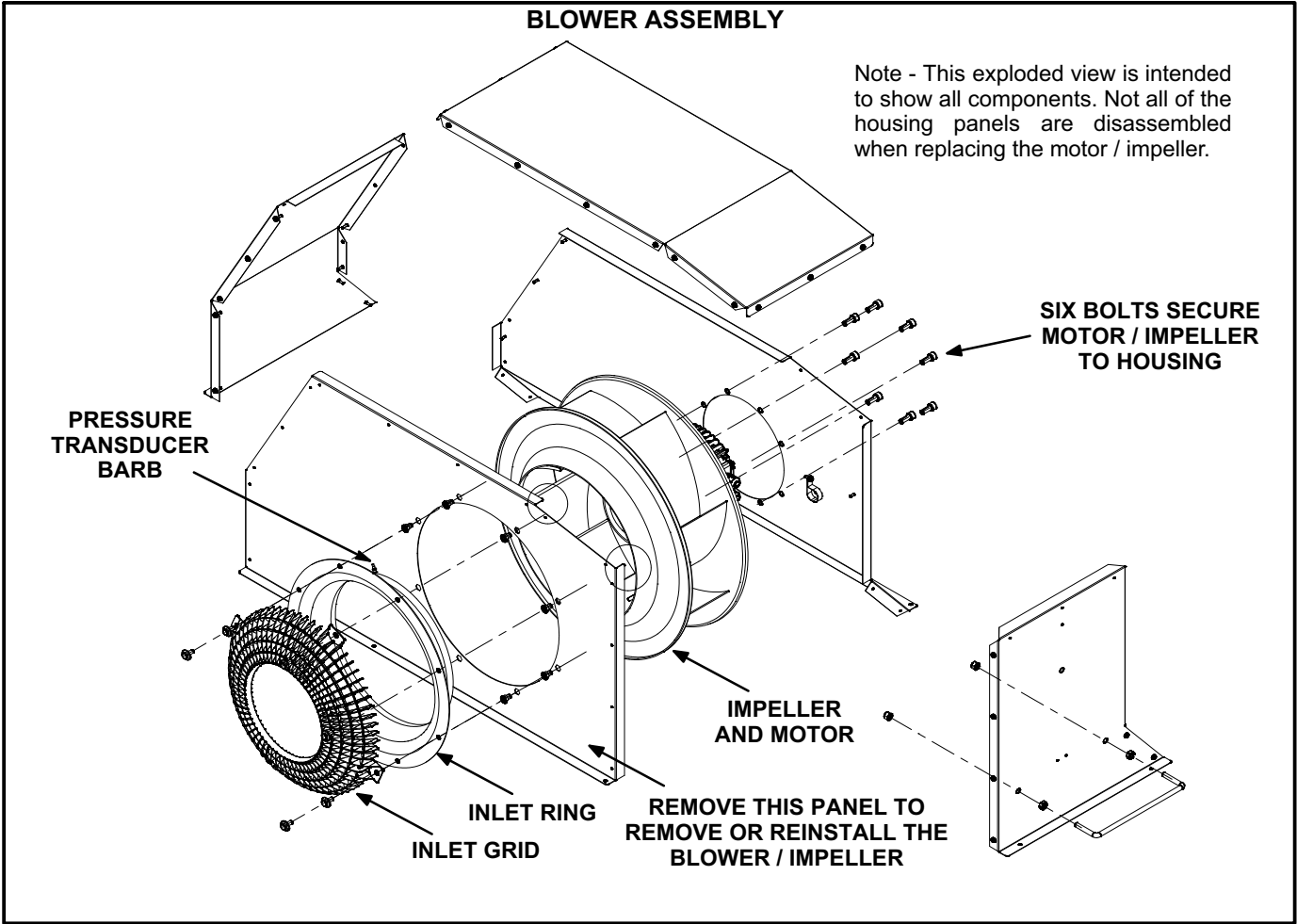

FIGURE 3

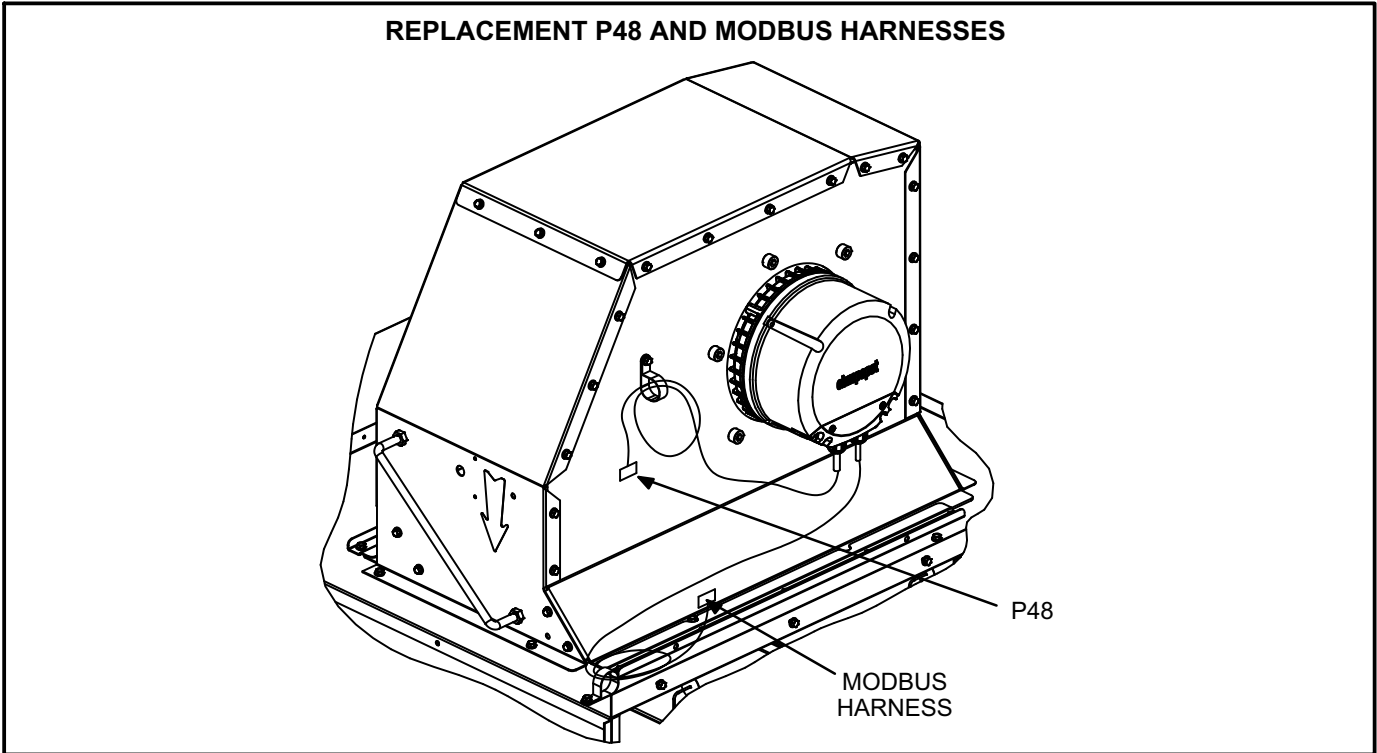

FIGURE 4