



L SERIES™

300 & 360 MODELS

"LCA" PACKAGED COOLING & ELECTRIC HEAT

"LGA" PACKAGED COOLING & GAS HEAT

Net Cooling Capacity - 267,900 to 318,000 Btuh (78.5 to 93.2 kW)
Gas Input Heating Capacity - 169,000 to 412,000 Btuh (49.5 to 120.7 kW)
Optional Electric Heat - 64,200 to 313,700 Btuh (18.8 to 91.9 kW)

LCA/LGA

25 & 30 Ton
(87.9 & 105.5 kW)

Bulletin #490070
December 1995



LCA360
(Cooling & Electric Heat)



LGA360
(Cooling & Gas Heat)

Table of Contents

Features	Page 2-3	Electrical Data	Page 10
Factory Installed Only Options	Page 3	Field Wiring	Page 11
Field Installed Only Accessories	Page 3	Electric Heat Data - LCA300	Page 12
Factory or Field Installed Accessories	Page 4	Electric Heat Data - LCA360	Page 12
Temperature Control Systems	Page 5	Cooling Ratings	Page 13
Temperature Control Selection Flowcharts	Page 6	Blower Data	Page 14-16
Model Number Identification	Page 7	Guide Specifications - LCA Models	Page 17
High Altitude Derate — LGA Models	Page 7	Guide Specifications - LGA Models	Page 18
Specifications	Page 8	Dimensions - LCA Models	Page 19
Optional Field Installed Accessories	Page 9	Dimensions - LGA Models	Page 20
Weight Data	Page 9	Dimensions - Accessories	Page 21-23
Optional Electric Heat Accessories	Page 10	Installation Clearances	Page 24

NOTE — Due to Lennox' ongoing commitment to quality, Specifications, Ratings and Dimensions subject to change without notice and without incurring liability.

FEATURES

ALL MODELS

Item	LCA/LGA300	LCA/LGA360
Air Flow Choice — Bottom (down-flow) or †horizontal (side) supply and return air	Standard	Standard
Approvals — Developed in accordance with ISO 9002 quality standards	Standard	Standard
Bottom Power Entry — For electrical and gas lines	Standard	Standard
Cabinet — Heavy gauge galvanized steel, fully insulated, powdered enamel paint finish, large removeable access panels, electrical inlets in cabinet base and electric heat end panel (LCA only), easy access control area with factory installed controls, low voltage terminal strip, unit lifting holes in base rail	Standard	Standard
Cabinet Access Panels (Hinged) — 2 compressor/controls/heating area access panels, 1 blower access panel and 1 air filter/economizer access panel hinged with tool-less access handles, gaskets on all edges for tight seal, access panels have steel panel inner liner with insulation sandwiched in-between	Standard	Standard
Coil Construction — Copper tube construction, ripple-edged enhanced aluminum fins, flared shoulder tubing connections, silver soldered construction, factory tested, evaporator coil face split with separate circuits, indoor coil drain connection extends outside of unit cabinet	Standard	Standard
Compressors — Copeland® Compliant Scroll™ type for high efficiency	Standard	Standard
Compressor Crankcase Heaters	Standard	Standard
Filters — Disposable 2 inch (51 mm) pleated commercial grade	Standard	Standard
Filter Access — Hinged filter door with tool-less access handles	Standard	Standard
Integrated Modular Control (IMC) — Solid-state board contains all controls and control relays to operate unit Built-in Functions Include: <ul style="list-style-type: none"> - Blower On/Off Delay - Built-in Control Parameter Defaults, ensure proper unit operation when power is restored after power failure - Service Relay Output - Dirty Filter Switch Input - Economizer Control, four modes of operation (outdoor enthalpy, differential enthalpy, temperature and global) - Electric Heat Staging, regulates electric heat during building warm-up - ETM Compatible, various modules (see factory or field installed accessories) - Extensive Unit Diagnostics, (80 diagnostic codes) - Permanent Diagnostic Code Storage - Field Changeable Control Parameters, (65 different parameters) - Gas Valve Delay Between First and Second Stage - Indoor Air Quality Input, monitors CO₂ levels, adjusts economizer dampers as needed (four modes of operation), requires optional field installed Indoor Air Quality (CO₂) Sensor - Low Ambient Controls — Allows unit cooling operation down to 0°F (-17.8°C) - Minimum Run Time - Night Setback Mode, adjusts setpoint, closes outdoor air dampers and operates blower on demand, may be customized for special requirements - Smoke Alarm Mode, (four modes of operation) - “Strike Three” Low Pressure Control, protects system from low suction pressure while eliminating nuisance faults - Thermostat Bounce Delay - Three Digit Display, (Displays: outdoor temperature, supply air temperature, return air temperature, economizer damper position, Indoor Air Quality, control parameters) - Two Stage Thermostat Compatible - Warm-up Mode, (four modes of operation) 	Standard	Standard
Outdoor Coil Construction — Slab type, angled design of coil (26°) inherently protects it from possible hail damage	Standard	Standard
Outdoor Coil Fans — Polyvinyl Chloride (PVC) coated fan guards furnished	Standard	Standard
Outdoor Coil Fan Motors — Overload protected, permanently lubricated, equipped with ball bearings, shaft up, wire basket mount	Standard	Standard
Refrigeration System — Consists of: compressors, condenser coils and direct drive fans, evaporator coil and belt drive blowers, expansion valves, high capacity driers, high pressure switches, low pressure switches, full refrigerant charge, crankcase heaters, freezestats (prevent coil freeze-up during low ambient operation or loss of air), independent refrigerant circuits (allows staging)	Standard	Standard
Rotalock Discharge and Suction Valves With Service Valve — For easy compressor servicing, also includes fully serviceable brass liquid line valve	----	Standard
Service Valves — Fully serviceable brass valves installed in discharge and liquid lines	----	Standard
Supply Air Blower — Belt drive, forward curved blades with double inlet, blower wheel statically and dynamically balanced, ball bearings, grease fittings furnished, adjustable pulley (allows speed change), blower assembly slides out of unit for servicing	Standard	Standard
Supply Air Motor (High Efficiency) — Overload protected, equipped with ball bearings	Standard	Standard

†With optional Horizontal Roof Mounting Frame and Horizontal Return Air Panel Kit.

FEATURES	LGA MODELS	
-----------------	-------------------	--

Item	LGA300	LGA360
Fan and Limit Controls — Factory installed, 90 second fan “on” time delay, dual limit controls (primary and secondary) with fixed temperature setting	Standard	Standard
Heat Exchanger — Tubular construction, aluminized steel, life cycle tested	Standard	Standard
Heating System — Aluminized steel inshot burners, direct spark ignition, electronic flame sensor, redundant automatic dual gas valve with manual shut-off, induced draft blower with differential pressure switch, flame rollout switch	Standard	Standard

FACTORY INSTALLED ONLY OPTIONS	ALL MODELS	
---------------------------------------	-------------------	--

Item	LCA/LGA300	LCA/LGA360
Corrosion Protection — Phenolic epoxy coating, applied to condenser coils (with painted base section) and evaporator coils (with painted evaporator base section and painted blower housings), factory applied to either section or both sections	Factory	Factory
Dirty Filter Switch — Pressure switch indicates dirty filter, relays information to Integrated Modular Control (furnished with unit)	Factory	Factory
Disconnect Switch — Accessible from outside of unit, spring loaded weatherproof cover furnished	Factory	Factory
Service Valves — Fully serviceable brass valves installed in discharge and liquid lines	Factory	Standard
Smoke Detector — Photoelectric type, factory installed in supply air section or return air section or both sections	Factory	Factory

FACTORY INSTALLED ONLY OPTIONS	LGA	
---------------------------------------	------------	--

Item	LGA300	LGA360
Standard Heat Gas Input — Factory installed (low fire/high fire) 169,000 and 228,000 Btuh (49.5 and 66.8 kW) input two stage heating capacity	Factory	Factory
High Heat Gas Input — Factory installed (low fire/high fire) 305,000 and 412,000 Btuh (89.4 and 120.7 kW) input two stage heating capacity	Factory	Factory

FIELD INSTALLED ONLY ACCESSORIES	ALL MODELS	
---	-------------------	--

Item	LCA/LGA300	LCA/LGA360
Control Systems — Electro-mechanical or Electronic Thermostat	Optional	Optional
Diffusers (Step-Down) — Aluminum grilles, double deflection louvers, large center grille, insulated diffuser box with flanges, hanging rings furnished, interior transition (even air flow), internally sealed (prevents recirculation), adapts to T-bar ceiling grids or plaster ceilings	LARTD30/36	
Diffusers (Flush) — Aluminum grilles, fixed blade louvers, large center grille, insulated diffuser box with flanges, hanging rings furnished, interior transition (even air flow), internally sealed (prevents recirculation), adapts to T-bar ceiling grids or plaster ceilings	LAFD30/36	
Horizontal Gravity Exhaust Dampers — Aluminum blade dampers prevent blow back and outdoor air infiltration during off cycle, field installed in return air duct, bird screen furnished	LAGEDH30/36	
Indoor Air Quality (CO₂) Sensor — Monitors CO ₂ levels, reports to Integrated Modular Control (IMC) board which adjusts economizer dampers as needed	18K51	
Roof Mounting Frame — Nailer strip furnished, mates to unit, U.S. National Roofing Contractors Approved, shipped knocked down	LARMF18/36-14 — 14 inch (356 mm) height or LARMF18/36-24 — 24 inch (610 mm) height	
Roof Mounting Frame (Horizontal) — Nailer strip furnished, mates to unit, converts unit from down-flow to horizontal (side) air flow, shipped knocked down, 41 inch (1041 mm) frame meets National Roofing Code requirements NOTE — Return air is on unit, supply air is on frame, see dimension drawings NOTE — Requires optional Horizontal Return Air Panel, see below	LARMFH30/36-30 30 inch (762 mm) height (for slab applications) or LARMFH30/36-41 41 inch (1041 mm) height (for rooftop applications)	
Horizontal Return Air Panel Kit — Required for horizontal applications with horizontal roof mounting frame, contains panel with return air opening for field replacement of existing unit panel and panel to cover bottom return air opening in unit, see dimension drawings	38K48	
Transitions (Supply and Return) — Used with diffusers, installs in roof mounting frame, galvanized steel construction, flanges furnished for duct connection, fully insulated	LASRT30/36	

FIELD INSTALLED ONLY ACCESSORIES	LGA	
---	------------	--

Item	LGA300	LGA360
LPG/Propane Kits	Optional	Optional

FACTORY OPTIONS OR FIELD INSTALLED ACCESSORIES

ALL MODELS

Item	LCA/LGA300	LCA/LGA360
Blower Proving Switch — Monitors blower operation, locks out unit in case of blower failure	Optional	Optional
Control Systems — See pages 5, 6 and 7 for complete listing	Optional	Optional
Economizer — Opposing gear driven recirculated air and outdoor air dampers, plug-in connections to unit, nylon bearings, neoprene seals, 24 volt fully modulating spring return motor, adjustable minimum damper position, damper assembly slides in unit, outdoor air hood must be ordered separately (see below), optional down-flow gravity exhaust dampers available (see below), choice of economizer controls (see below)		LAREMD30/36
Economizer Control Choice —		
Sensible Control — Furnished on IMC board in unit, uses outdoor air sensor furnished with unit to measure outdoor air temperature and control damper position	Furnished with unit	Furnished with unit
Outdoor Enthalpy Control — Adjustable enthalpy sensor, senses outdoor air enthalpy for economizer control, 0 to 100% outdoor air, adjustable minimum positioner	Optional	Optional
Differential Enthalpy Control — Two solid-state enthalpy sensors allow selection between outdoor air and return air (whichever has lowest enthalpy)	Optional	Optional
Global Control — Furnished on IMC board in unit, used with Direct Digital Control (DDC) systems, uses global air sensor to control damper position, determines when to use outdoor air for cooling or set damper at minimum position	Furnished with unit	Furnished with unit
Down-Flow Gravity Exhaust Dampers — Aluminum blade dampers prevent blow back and outdoor air infiltration during off cycle, bird screen furnished		LAGED30/36
Outdoor Air Damper Section (Automatic Operation) — Gear driven mechanical dampers, 0 to 25% outdoor air adjustable, fully modulating spring return damper motor, plug-in connection, installs in unit cabinet, outdoor air hood must be ordered separately (see below)		LAOADM30/36
Outdoor Air Damper Section (Manual Operation) — Linked mechanical dampers, 0 to 25% (fixed) outdoor air adjustable, installs in unit cabinet, outdoor air hood must be ordered separately (see below)		LAOAD30/36
Outdoor Air Hood — Required with LAREMD30/36 Economizer, LAOAD30/36 and LAOADM30/36 Outdoor Air Damper Sections, five cleanable aluminum mesh fresh air filters furnished		LAOAH30/36
Power Exhaust Fans — Installs in unit for down-flow applications only with economizer option, provide exhaust air pressure relief, interlocked to run when return air dampers are closed and supply air blowers are operating, fans run when outdoor air dampers are 50% open (adjustable), overload protected, requires down-flow gravity exhaust dampers (see above)		LAPEF30/36

FACTORY OPTIONS OR FIELD INSTALLED ACCESSORIES

LCA

Item	LCA300	LCA360
Electric Heat (EHA) — Factory or field installed, helix wound nichrome elements, time delay for element staging, individual element limit controls (45, 60, 90 and 120 kW), may be two-stage controlled, requires optional Electric Heat Control Module, Fuse Block and Terminal Block	Optional	Optional
Electric Heat Control Module — Required with 45, 60, 90 and 120 kW electric heaters, provides control of second stage heating, see Optional Electric Heat Accessories Table	Optional	Optional
Electric Heat Fuse Block — Mounting screws furnished, see Optional Electric Heat Accessories Table	Optional	Optional
Electric Heat LTB2 Terminal Block — Required with electric heat, see Optional Electric Heat Accessories Table	Optional	Optional

OPTIONAL DDC TEMPERATURE CONTROL SYSTEM (Field Installed)

System and Component Description	Field Installed Catalog No.
NOVAR ETM-2050 KIT	—
Control Module/Blower Proving Switch/Return Air Sensor/Discharge Air Sensor/Wiring Harness — Control module monitors unit operation from different sensors installed in unit, has outputs for 2 stage heat/2 stage cool, automatic or continuous blower operation, economizer damper operation and night setback, features: day/occupied mode with low enthalpy (outdoor air damper open), high enthalpy (outdoor air damper closed) or night/unoccupied mode (outdoor air damper closed), network communication (RS-485, shielded pair twisted wire), local override (1 to 255 minutes), watchdog function, failsafe operation, ETM allows units to be “daisy chained” together (up to 31 units) to be operated from one central location with an “executive” type control processor (onsite or offsite), built-in time delays, built-in unit operating defaults, diagnostic LED’s indicate various operating functions, surge suppression protects ETM against lightning or voltage spikes, Blower Proving Switch monitors blower operation and locks out unit in case of blower failure, Return Air Sensor provides input to ETM module to determine heating or cooling operation and number of stages required, Discharge Air Sensor monitors leaving air temperature during unit operation	16K91
Dirty Filter Switch — Senses static pressure increase indicating a dirty filter condition	30K48
Room Temperature Sensor — Provides input to ETM module to determine heating or cooling operation and number of stages required (ordered separately)	97H53
Night Setback Override Switch — Allows momentary override of night setback during unoccupied mode	Field Furnished

OPTIONAL CONVENTIONAL TEMPERATURE CONTROL SYSTEMS (Field Installed)

System and Component Description	Catalog No.
ELECTRO-MECHANICAL THERMOSTAT	—
Thermostat — Two stage heat & two stage cool with dual temperature levers, subbase choice	13F06
Subbase — Manual system switch (Off-Heat-Auto-Cool), fan switch (Auto-On)	13F17
Subbase — Non-switching	13F16
Night Setback Operation — Order components below	—
Heating Thermostat — Single stage heat	13F12
Subbase — Non-switching	13F16
Time Clock — 7 day operation, indicates day and night periods, 2 hour increments, battery back-up	See Price Book for Selection
Time Clock — 24 hour night setback operation, 15 minute increments, battery back-up	See Price Book for Selection
Blower Proving Switch — Monitors blower operation, locks out unit in case of blower failure	30K49
Dirty Filter Switch — Senses static pressure increase indicating a dirty filter condition	30K48
ELECTRONIC THERMOSTAT	—
Electronic Thermostat — Any two stage heat/ two stage cool electronic thermostat may be used.	See Price Book for Selection
Time Clock — 7 day operation, indicates day and night periods, 2 hour increments, battery back-up	See Price Book for Selection
Time Clock — 24 hour night setback operation, 15 minute increments, battery back-up	See Price Book for Selection
Blower Proving Switch — Monitors blower operation, locks out unit in case of blower failure	30K49
Dirty Filter Switch — Senses static pressure increase indicating a dirty filter condition	30K48
HONEYWELL T7300 THERMOSTAT	—
Thermostat — Programmable, internal or optional remote temperature sensing (sensor required), touch sensitive keyboard, automatic switching, °F or °C readout, no anticipator, droop/no droop selection, indicator LED’s, hour/day programming, override capabilities, time and operational mode readout, stage status indicators, battery back-up, subbase choice	81G59
Subbase — Selectable staging up to two stage heat & two stage cool, manual system switch (Heat-Off-Auto-Cool), fan switch (Auto-On), indicator LED’s, auxiliary relay output for economizer operation	81G60
Sensor — Room temperature	58C92
Sensor — Room temperature with 3 hour override and setpoint adjustment	86G67
Sensor — Return air temperature	27C40
Blower Proving Switch — Monitors blower operation, locks out unit in case of blower failure	30K49
Dirty Filter Switch — Senses static pressure increase indicating a dirty filter condition	30K48

DDC TEMPERATURE CONTROL SELECTION FLOWCHARTS

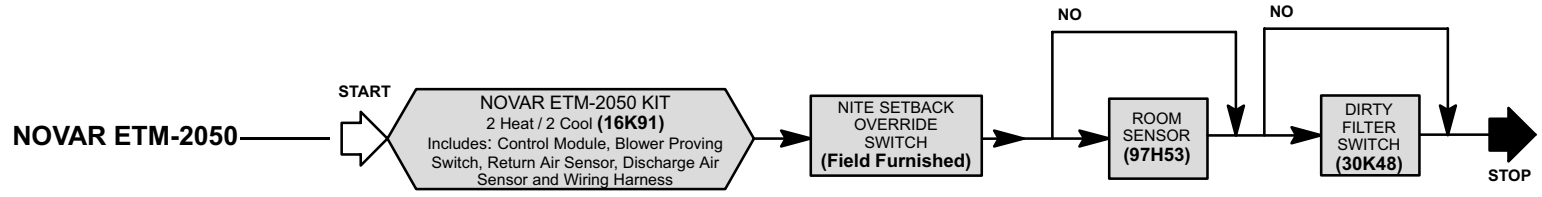

CONVENTIONAL TEMPERATURE CONTROL SELECTION FLOWCHARTS

ELECTRO-MECHANICAL THERMOSTAT

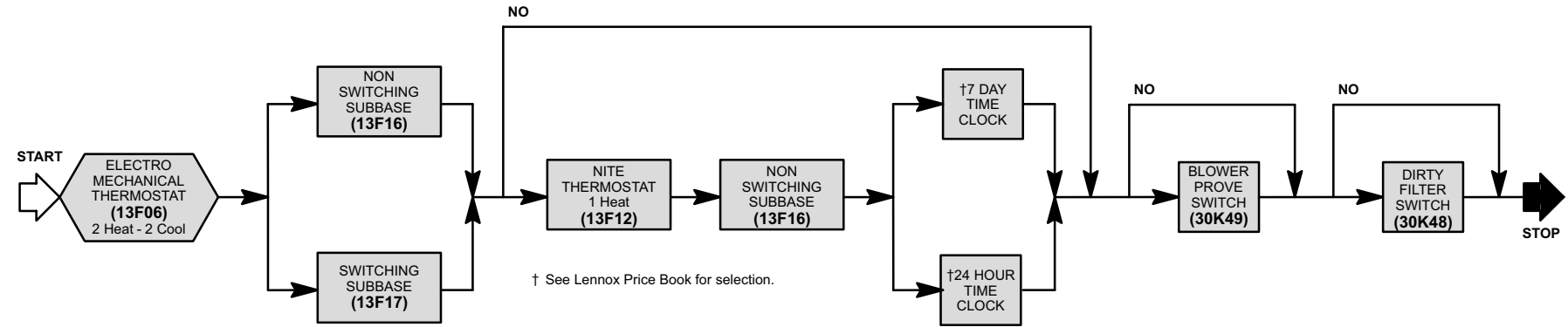

ELECTRONIC THERMOSTAT

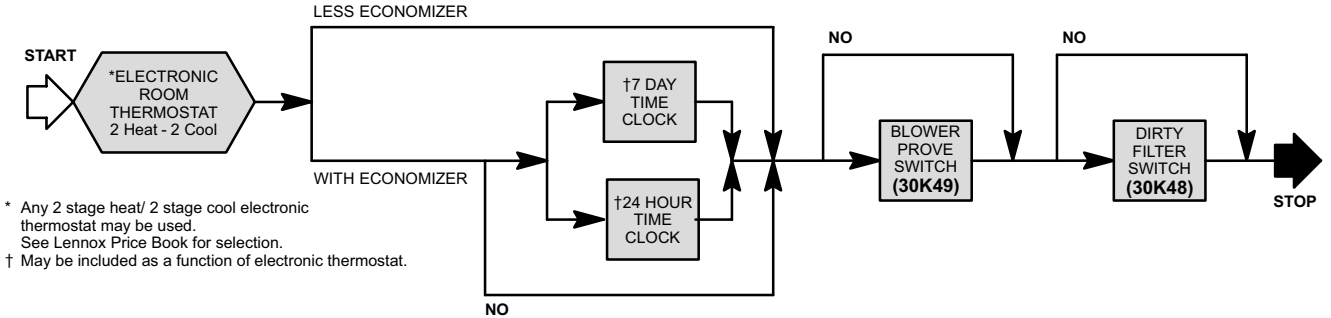

HONEYWELL T7300 THERMOSTAT

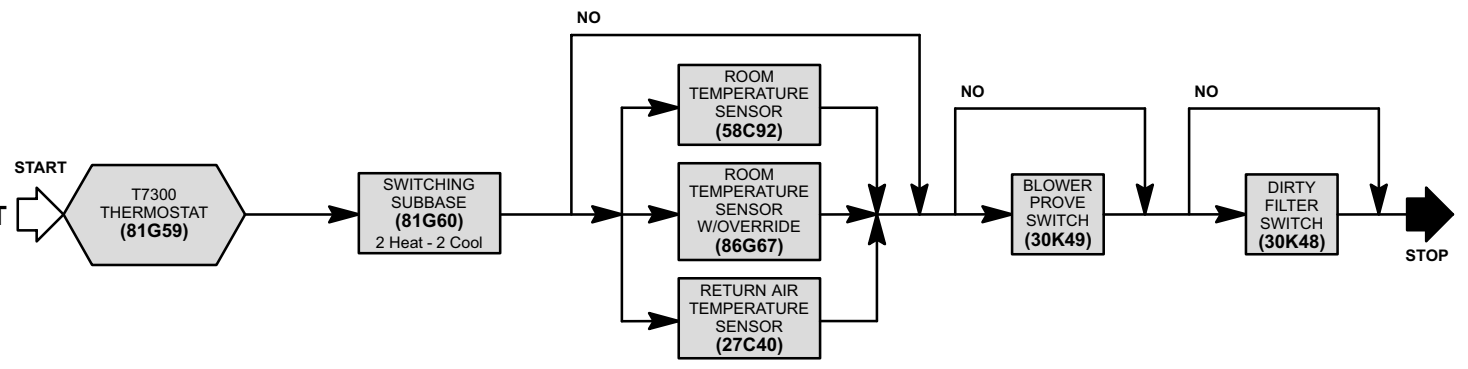

MODEL NUMBER IDENTIFICATION

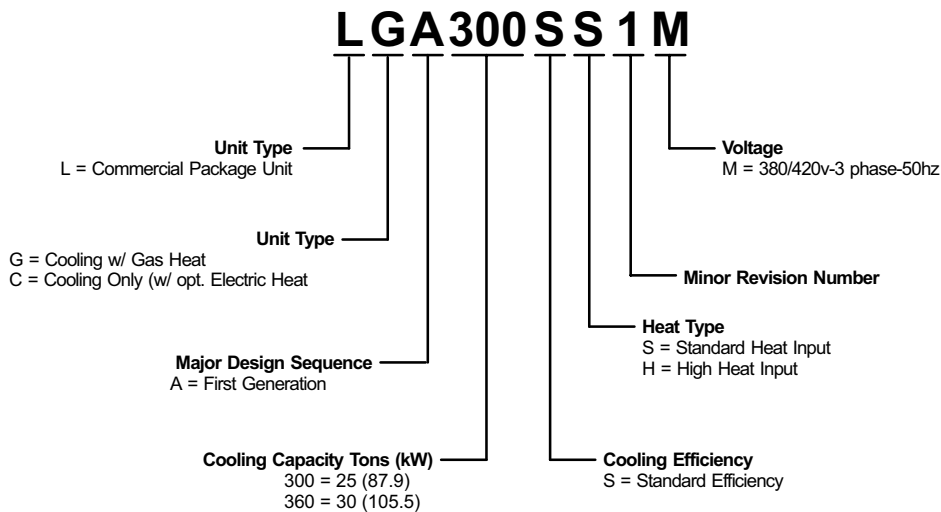

FACTORY INSTALLED OPTIONS

BLOWER MOTORS

- 5 hp (3.7 kW) high efficiency
- 7.5 hp (5.6 kW) high efficiency
- 10 hp (7.5 kW) high efficiency

*BLOWER DRIVES

- Drive option 1 or 2 w/ 5 hp (3.7 kW) motor
- Drive option 3 or 4 w/ 7.5 hp (5.6 kW) motor
- Drive option 3 or 5 w/ 10 hp (7.5 kW) motor

*See Blower Performance table for specifications.

TECHNICOAT CORROSION PROTECTION

- Condenser Coils and Base Section
- Evaporator Coils, Base Section and Blower Housings

ECONOMIZER

ECONOMIZER CONTROLS

- Sensible Control
- Outdoor Enthalpy Control
- Differential Enthalpy Control
- Global Control

OUTDOOR AIR DAMPERS

- Manual Control
- Automatic Control

POWER EXHAUST FANS

GRAVITY EXHAUST DAMPERS (Down-Flo Applications Only)

ELECTRICAL

- Single Point Power Supply
- Unit Disconnect

HEAT SELECTION

GAS HEAT (Two Stage)

- Standard Heat Input (low fire/high fire)
169 000 and 228 000 Btuh (49.5 and 66.8 kW)
- High Heat Input (low fire/high fire)
305 000 and 412 000 Btuh (89.4 and 120.7 kW)

ELECTRIC HEAT

- 30 kW
- 45 kW
- 60 kW
- 90 kW
- 120 kW

REFRIGERATION SYSTEM

- *Service Valves (optional for LCA/LGA300)
- *Standard with LCA/LGA360 models.

DDC CONTROL SYSTEMS

- Novar ETM-2050

DIRTY FILTER SWITCH

BLOWER PROVING SWITCH

SMOKE DETECTORS

- Smoke Detector (Return Air)
- Smoke Detector (Supply Air)

HIGH ALTITUDE DERATE (LGA Models)

Units may be installed at altitudes up to 2000 feet (610 m) above sea level without any modification. At altitudes above 2000 feet (610 m), units must be derated to match gas manifold pressures shown in table below.

NOTE — This is the only permissible derate for these units.

Altitude - ft. (m)	Gas Manifold Pressure - in. w.g. (kPa)
2001 - 3000 (610 - 915)	3.6 (0.90)
3001 - 4000 (915 - 1220)	3.5 (0.87)
4001 - 5000 (1220 - 1525)	3.4 (0.85)
5001 - 6000 (1525 - 1830)	3.3 (0.82)
6001 - 7000 (1830 - 2135)	3.2 (0.80)
7001 - 8000 (2135 - 2440)	3.1 (0.77)

SPECIFICATIONS

ALL MODELS

Model Number		LCA/LGA300H	LCA/LGA360H	
Evaporator Blower and Drive Selection	Blower wheel nominal diameter x width — in. (mm)	(2) 18 x 15 (457 x 381)		
	5 hp (3.7 kW) *Motor and Drives	Nominal motor output — hp (kW)	5 (3.7)	
		Voltage and phase	380/420v-50hz-3 phase with neutral	
		Rev/min range (Drive option 1 or 2)	630 - 790 or 710 - 900	
	7.5 hp (5.6 kW) *Motor and Drives	Nominal motor horsepower (kW)	7.5 (5.6)	
		Voltage and phase	380/420v-50hz-3 phase with neutral	
		Rev/min range (Drive option 3 or 5)	710 - 870 or 830 - 980	
	10 hp (7.5 kW) *Motor and Drives	Nominal motor output — hp (kW)	10 (7.5)	
		Voltage and phase	380/420v-50hz-3 phase with neutral	
Rev/min range (Drive option 4 or 5)		700 - 840 or 870 - 1020		
Evaporator Coil	Net face area — sq. ft. (m ²)	33.3 (3.1)	33.3 (3.1)	
	Tube diameter — in. (mm) and No. of rows	3/8 (9.5) — 2	3/8 (9.5) — 3	
	Fins per inch (m)	14 (551)	14 (551)	
	Drain connection no. and size — in. (mm) fpt	(1) 1 (25)	(1) 1 (25)	
	Expansion device type	Balanced Port Thermostatic Expansion Valve, removeable power head		
Condenser Coil	Net face area — sq. ft. (m ²)	70.6 (6.6)	70.6 (6.6)	
	Tube diameter — in. (mm) and No. of rows	3/8 (9.5) — 2	3/8 (9.5) — 2	
	Fins per inch (m)	16 (630)	16 (630)	
Condenser Fans	Diameter — in. (mm) and No. of blades	(6) 24 (610 — 3		
	Total Air volume — cfm (L/s)	18 500 (8730)		
	Motor horsepower (W)	(6) 1/3 (249)		
	Motor Rev/min	900		
	Total Motor watts	1660		
Filters (furnished)	Type of filter	Disposable, commercial grade, pleated		
	No. and size — in. (mm)	(12) 20 x 20 x 2 (508 x 508 x 51)		
Electrical characteristics		380/420v-50hz-3 phase with neutral		

*Using total air volume and system static pressure requirements, determine from blower performance tables Rev/min and motor output required. Select proper motor size and drive combination to obtain required rev/min and air flow. If motors of comparable output are used, be sure to keep within the service factor limitations outlined on the motor name-plate.

COOLING CAPACITY

ALL MODELS

Model Number		LCA/LGA300H	LCA/LGA360H
Cooling Ratings	Gross Cooling Capacity — Btuh (kW) (kcal)	267 900 (78.5) (67 500)	318 000 (93.2) (80 100)
	*Net Cooling Capacity — Btuh (kW) (kcal)	254 000 (74.4) (64 000)	302 000 (88.5) (76 100)
	Total Unit Power (kW)	25.3	30.0
	*Energy Efficiency Ratio (Btuh/Watt)	10.0	10.0
	Coefficient of Performance - Output/Input	2.94	2.95
Refrigerant Charge Furnished (HCFC-22)	Circuit 1	11 lbs. 0 oz. (4.99 kg)	18 lbs. 0 oz. (8.16 kg)
	Circuit 2	11 lbs. 0 oz. (4.99 kg)	18 lbs. 0 oz. (8.16 kg)
	Circuit 3	11 lbs. 0 oz. (4.99 kg)	18 lbs. 0 oz. (8.16 kg)
	Circuit 4	11 lbs. 0 oz. (4.99 kg)	----

*Rated test conditions are those included in in Air Conditioning and Refrigeration Institute (ARI) Standard 360-86 while operating at rated voltage and air volumes.

Cooling Ratings: 95°F (35°C) outdoor air temperature and 80°F (27°C) db/67°F (19°C) wb entering evaporator air; minimum external duct static pressure.

NOTE — Net capacity includes evaporator blower motor heat deduction. Gross capacity does not include evaporator blower motor heat deduction.

GAS HEATING CAPACITY

LGA

Model Number		LGA300H		LGA360H	
Heat Input Type		Standard	High	Standard	High
Two Stage Heating Capacity (Natural or LPG/Propane Gas (at Sea Level)	Input (low) — Btuh (kW) (kcal)	169 000 (49.5) (42 600)	305 000 (89.4) (76 900)	169 000 (49.5) (42 600)	305 000 (89.4) (76 900)
	Output (low) — Btuh (kW) (kcal)	135 000 (39.6) (34 000)	244 000 (71.5) (61 500)	135 000 (39.6) (34 000)	244 000 (71.5) (61 500)
	Input (High) — Btuh (kW) (kcal)	228 000 (66.8) (57 500)	412 000 (120.7) (10 400)	228 000 (66.8) (57 500)	412 000 (120.7) (10 400)
	Output (High) — Btuh (kW) (kcal)	182 000 (53.4) (45 900)	330 000 (96.7) (83 200)	182 000 (53.4) (45 900)	330 000 (96.7) (83 200)
	Thermal Efficiency	80.0%	80.0%	80.0%	80.0%
Gas Supply Connections npt - in.	Natural	1			
	*LPG/Propane	1			
Recommended Gas Supply Pressure - wc. in. (kPa)	Natural	7 (1.7)			
	*LPG/Propane	11 (2.7)			

*For LPG/Propane units a field conversion kit is required and must be ordered extra.

OPTIONAL FIELD INSTALLED ACCESSORIES

ALL MODELS

Unit Model Number		LCA/LGA300H and LCA/LGA360H	
LPG/Propane Conversion Kit (LGA models only)		19K52 (2 kits required)	
Down-Flow Roof Mounting Frame (Net Weight)	14 inch (356 mm) height	LARMF18/36-14 (160 lbs.) (73 kg) (16K87)	
	24 inch (610 mm) height	LARMF18/36-24 (220 lbs.) (100 kg) (16K88)	
Horizontal Roof Mounting Frame (Net Weight) (Horizontal Return Air Panel Required - Order Separately)	30 inch (762 mm) height (for slab applications)	LARMFH30/36-30 (445 lbs.) (202 kg) (33K79)	
	41 inch (1041 mm) height (for rooftop applications)	LARMFH30/36-41 (725 lbs.) (329 kg) (38K54)	
Horizontal Return Air Panel Kit — (Net Weight)		38K48 (43 lbs.) (20 kg)	
Economizer (Outdoor Air Hood Required - Order Separately)	Model Number — (Net Weight)	LAREMD30/36 (98 lbs.) (45 kg) (33K72)	
Outdoor Air Hood — (Net Weight) Number, size and type of filters — in. (mm)		LAOAH30/36 (33K71) (55 lbs.) (25 kg) required with Economizer (5) 16 x 25 x 1 (406 x 635 x 25) aluminum mesh	
Outdoor Enthalpy Control		16K96	
Differential Enthalpy Control		16K97	
Gravity Exhaust Dampers	Down-Flow — (Net Weight)	LAGED30/36 (28 lbs.) (13 kg) (33K77)	
	*Horizontal — (Net Weight)	LAGEDH30/36 (20 lbs.) (9 kg) (33K78)	
Power Exhaust Fans (Down-Flo Only) (Available With Economizer Only, Down-flow Gravity Exhaust Dampers Required)	Model Number (Net Weight)	208/230v	LAPEF30/36 (90 lbs.) (41 kg) (33K73)
		460v	LAPEF30/36 (96 lbs.) (44 kg) (33K74)
		575v	LAPEF30/36 (99 lbs.) (45 kg) (33K75)
	Diameter — in. (mm) and No. of Blades		(3) 20 (508) — 5
	Total air volume — cfm (L/s)		10 670 (5035) @ 0 in. w.g. (0 Pa)
	Motor Horsepower (W)		(3) 1/3 (249)
Total Watts input		860	
Ceiling Supply and Return Air Diffusers (Net Weight)	Step-Down	LARTD30/36 (437 lbs.) (198 kg) (35K25)	
	Flush	LAFD30/36 (414 lbs.) (188 kg) (35K24)	
	Transition	LASRT30/36 (85 lbs.) (39 kg) (33K80)	
Outdoor Air Damper (Manual Operation) — (Net Weight) (Outdoor Air Hood Required - Order Separately)		LAOAD30/36 (55 lbs.) (25 kg) (33K69)	
Outdoor Air Damper (Automatic Operation) — (Net Weight) (Outdoor Air Hood Required - Order Separately)		LAOADM30/36 (60 lbs.) (27 kg) (33K70)	
Outdoor Air Hood — (Net Weight) Number, size and type of filters — in. (mm)		LAOAH30/36 (33K71) (55 lbs.) (25 kg) required with Outdoor Air Damper (5) 16 x 25 x 1 (406 x 635 x 25) aluminum mesh	
Indoor Air Quality (CO ₂) Sensor		18K51	

*Field installs in return air duct. Two dampers furnished per order no.

WEIGHT DATA

ALL MODELS

Model Number	Description	Weight	
		lbs.	kg
Net Weights			
LCA300H	Net weight (Base unit)	2910	1320
LCA360H	Net weight (Base unit)	3220	1461
LGA300H	Net weight (Base unit with low fire heat exchanger)	3020	1370
LGA360H	Net weight (Base unit with low fire heat exchanger)	3330	1510
Shipping Weights (Add Factory Installed Options Weights To Base Unit Weights For Total Shipping Weight)			
LCA300H	Base unit	3120	1415
LCA360H	Base unit	3430	1556
LCA Models	Electric Heat (add to Base unit)	78	35
LGA300H	Base unit with low fire heat exchanger	3230	1465
LGA360H	Base unit with low fire heat exchanger	3540	1606
LGA Only	High Fire Heat Exchanger (add to Base unit)	28	13
All Models	Economizer (add to Base unit)	98	44
	Outdoor Air Damper (add to Base unit)	55	25
	Power Exhaust (add to Base unit)	90	41
	LTL Packaging (less than truck load) (add to Base unit)	300	136

ELECTRIC HEAT CONTROL MODULE AND UNIT FUSE BLOCKS

Unit Model Number		LCA300H	LCA360H	
Electric Heat	Model Number	EHA (see Electric Heat Data tables for additional information)		
	kW Input Range	30-45-60-90-120		
Electric Heat Control Module (45, 60, 90 and 120 kW)		37K11		
Unit Fuse Block (3 phase)	Without Power Exhaust Fans	5 hp (3.7 kW)	25K14	35K03
		7.5 hp (5.6 kW)	25K14	35K04
		10 hp (7.5 kW)	35K03	35K04
	With Power Exhaust Fans	5 hp (3.7 kW)	25K14	35K04
		7.5 hp (5.6 kW)	35K03	35K04
		10 hp (7.5 kW)	35K03	35K04

LTB2 ELECTRIC HEAT TERMINAL BLOCK

LTB2-175 (30K75) 175 amps, LTB2-335 (30K76) 335 amps

(Required For Units Without Disconnect/Circuit Breaker But With Single Point Power Source)

LTB2 Terminal Block (3 phase)	Unit Model Number		LCA300H and LCA360H	
	30 kW	5 hp (3.7 kW)		30K75
7.5 hp (5.6 kW)			30K75	
10 hp (7.5 kW)			30K75	
45 kW	5 hp (3.7 kW)		30K75	
	7.5 hp (5.6 kW)		30K75	
	10 hp (7.5 kW)		30K76	
60 kW	5 hp (3.7 kW)		30K75	
	7.5 hp (5.6 kW)		30K76	
	10 hp (7.5 kW)		30K76	
90 kW	5 hp (3.7 kW)		30K76	
	7.5 hp (5.6 kW)		30K76	
	10 hp (7.5 kW)		30K76	
120 kW	5 hp (3.7 kW)		30K76	
	7.5 hp (5.6 kW)		30K76	
	10 hp (7.5 kW)		30K76	

NOTE — Terminal Block is factory installed in units with factory installed electric heat without disconnect/circuit breaker but with single point power source.

ELECTRICAL DATA

ALL MODELS

Model Number		LCA/LGA300H			LCA/LGA360H			
Line voltage data — 50 Hz — 3 phase with neutral		380/420v			380/420v			
Compressors (4) - 300 (3) - 360	Rated load (A) each (total)	9.0 (36.0)			14.3 (42.9)			
	Locked rotor (A) each (total)	70.0 (280.0)			116.0 (348.0)			
Condenser Fan Motors (6)	Full load (A) (total)	7.8			7.8			
	Locked rotor (A) (total)	14.4			14.4			
Evaporator Blower Motor	Motor Output	hp	5	7.5	10	5	7.5	10
		kW	3.7	5.6	7.5	3.7	5.6	7.5
	Full load (A)	7.6	11	14	7.6	11	14	
	Locked rotor (A)	45.6	66	84	45.6	66	84	
Optional Power Exhaust Fans	(No.) Horsepower (W)	(3) 1/3 (249)			(3) 1/3 (249)			
	Full load (A) (total)	3.9			3.9			
	Locked rotor (A) (total)	7.2			7.2			
Electric Heat - Per Element (A)		15.7						

*Refer to local electrical codes to determine wire, fuse and disconnect size requirements. Use wires suitable for at least 167°F (75°C).

NOVAR ETM-2050 CONTROL SYSTEM

- A — Three phase with neutral (See Electrical Data Table)
- B — RS-485 shielded pair twisted wire
- C — Four wire 24V
- D — Two wire 24V

— Field wiring not furnished —

NOTE — All wiring must conform to local electrical codes.

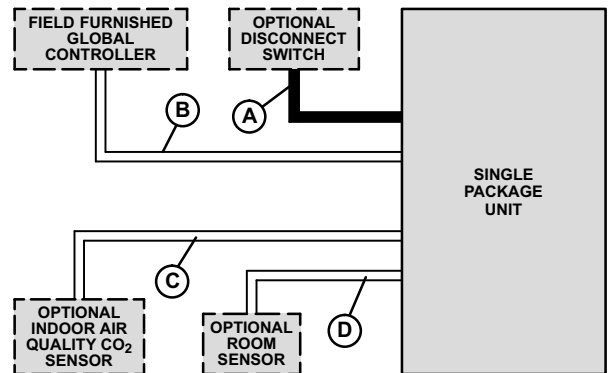

ELECTRO-MECHANICAL, ELECTRONIC OR HONEYWELL T7300 THERMOSTAT CONTROL SYSTEM

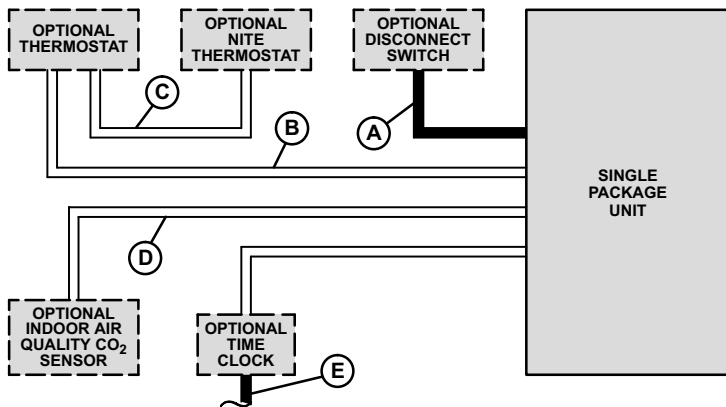

- A — Three phase with neutral (See Electrical Data Table)
- B — Six wire 24V (Electro-Mechanical)
Seven wire 24V (Electronic)
Nine wire 24V (Honeywell T7300)
Ten wire 24V (Honeywell T7300 with Service LED)
- C — Two wire 24V (Electro-Mechanical Only)
- D — Four wire 24V (All Systems)
- E — Two wire power

— Field wiring not furnished —

NOTE — All wiring must conform to local electrical codes.

300 AND 360 SIZE

kW Size	Electric Heat Model Number (see footnote) Net Weight	Number of Elements	Volts Input	Total Heating Capacity - 50hz		
				kW	kcal	Btuh
25 kW	●(1) EHA360-15 (99J24) and ●(1) EHA360S-15 (99J25) 59 lbs. (27 kg) (total weight)	1	380	18.8	16 200	64 200
		1	400	20.9	18 000	71 300
		1	420	23.0	19 800	78 400
40 kW	★(2) EHA360-22.5 (99J29) 76 lbs. (35 kg) (total weight)	*2	380	28.2	24 300	96 300
		*2	400	31.4	25 500	107 000
		*2	420	34.4	26 600	117 600
50 kW	★(2) EHA150-30 (99J08) 76 lbs. (35 kg) (total weight)	*2	380	37.6	32 400	128 400
		*2	400	41.8	36 000	142 600
		*2	420	45.9	39 500	156 800
60 kW	★(2) EHA150-45 (99J11) 84 lbs. (38 kg) (total weight)	*2	380	56.4	48 500	192 500
		*2	400	62.6	53 900	213 800
		*2	420	68.9	59 200	235 100
90 kW	★(2) EHA150-60 (99J14) 98 lbs. (45 kg) (total weight)	*2	380	75.2	64 700	256 800
		*2	400	83.6	71 900	285 300
		*2	420	91.9	79 100	313 700

●NOTE - For field installed electric heat, order (1) of each heater shown to make up heater size required.

★NOTE - For field installed electric heat, order (2) of same heater shown to make up heater size required.

*May be used with two stage control.

NOTE — Fuse block must be ordered extra. Factory installed heaters will have the fuse block factory installed. Fuse block must be installed in field installed heaters. Also requires LTB2 Terminal Block. See Optional Electric Heat Accessories tables.

†Electric Heat Control Module required on 45, 60 and 90 kW sizes only (module furnished with factory installed electric heaters). See Optional Electric Heat Accessories tables.

FACTORY INSTALLED DRIVE KIT SPECIFICATIONS

Motor Outputs		Rev/Min Range				
hp	kW	Drive 1	Drive 2	Drive 3	Drive 4	Drive 5
5	3.7	630/790	710/900	----	----	----
7.5	5.6	----	----	710/870	----	830/980
10	7.5	----	----	----	700/840	870/1020

**FACTORY INSTALLED OPTIONS/FIELD INSTALLED ACCESSORY
AIR RESISTANCE**

Air Volume		Total Resistance — inches water gauge (Pa)						
		Wet Indoor Coil		Gas Heat Exchanger (LGA Models)		Electric Heat (LCA Models)	Economizer	Horizontal Roof Mounting Frame
cfm	m ³ /s	300H	360H	Low Fire	High Fire			
7500	3.55	.04 (10)	.07 (17)	.15 (37)	.25 (62)	.03 (7)	.02 (5)	.11 (27)
8000	3.80	.05 (12)	.08 (20)	.17 (42)	.28 (70)	.03 (7)	.02 (5)	.13 (32)
8500	4.0	.05 (12)	.08 (20)	.20 (50)	.31 (77)	.04 (10)	.03 (7)	.15 (37)
9000	4.25	.06 (15)	.09 (22)	.22 (55)	.34 (85)	.04 (10)	.04 (10)	.17 (42)
9500	4.50	.06 (15)	.10 (25)	.24 (60)	.38 (94)	.05 (12)	.04 (10)	.19 (47)
10,000	4.70	.07 (17)	.11 (27)	.27 (67)	.42 (104)	.05 (12)	.05 (12)	.21 (52)
10,500	4.95	.07 (17)	.12 (30)	.30 (75)	.46 (114)	.06 (15)	.06 (15)	.24 (60)
11,000	5.20	.08 (20)	.12 (30)	.33 (92)	.50 (137)	.06 (15)	.07 (17)	.27 (67)
11,500	5.45	.08 (20)	.13 (32)	.37 (92)	.55 (137)	.07 (17)	.08 (20)	.30 (75)
12,000	5.65	.09 (22)	.14 (35)	.40 (99)	.60 (149)	.07 (17)	.10 (25)	.33 (82)
12,500	5.90	.09 (22)	.15 (37)	.44 (109)	.65 (162)	.08 (20)	.11 (27)	.37 (92)
13,000	6.15	.10 (25)	.16 (40)	.48 (119)	.70 (174)	.08 (20)	.13 (32)	.40 (99)
13,500	6.35	.11 (27)	.17 (42)	.53 (132)	.76 (189)	.09 (22)	.14 (35)	.44 (109)
14,000	6.60	.11 (27)	.18 (45)	.57 (142)	.82 (204)	.10 (25)	.16 (40)	.49 (122)
14,500	6.85	.12 (30)	.19 (47)	.62 (154)	.89 (221)	.10 (25)	.18 (45)	.53 (132)
15,000	7.10	.13 (32)	.20 (50)	.68 (169)	.95 (236)	.11 (27)	.21 (52)	.58 (144)

CEILING DIFFUSER AIR RESISTANCE

Unit Size	Air Volume		Total Resistance — inches water gauge (Pa)			
			LARTD30/36 Step-Down Diffuser			LAFD30/36 Flush Diffuser
	cfm	m ³ /s	2 Ends Open	1 Side 2 Ends Open	All Ends & Sides Open	
300 & 360 Models	7500	3.55	.37(92)	.31 (77)	.25(62)	.29 (72)
	8000	3.80	.42 (104)	.36 (90)	.29 (72)	.34 (85)
	8500	4.00	.48 (119)	.41 (102)	.34 (85)	.39 (97)
	9000	4.25	.55 (137)	.47 (117)	.39 (97)	.44 (109)
	9500	4.50	.62 (154)	.53 (132)	.45 (112)	.51 (127)
	10 000	4.70	.70 (1740)	.60 (149)	.51 (127)	.57 (142)
	10 500	4.95	.78 (194)	.68 (169)	.58 (144)	.65 (162)
	11 000	5.20	.87 (216)	.76 (190)	.65 (162)	.72 (179)
	11 500	5.45	.97 (241)	.85 (211)	.73 (182)	.81 (201)
	12 000	5.65	1.08 (269)	.94 (234)	.82 (204)	.90 (223)
	12 500	5.90	1.19 (296)	1.04 (259)	.91 (226)	.99 (246)
	13 000	6.15	1.30 (323)	1.15 (286)	1.00 (249)	1.10 (274)
	13 500	6.35	1.43 (356)	1.26 (313)	1.10 (374)	1.20 (298)
	14 000	6.60	1.56 (388)	1.38 (343)	1.20 (298)	1.31 (326)
	14 500	6.85	1.69 (420)	1.50 (373)	1.31 (326)	1.43 (356)
	15 000	7.10	1.84 (457)	1.63 (405)	1.43 (356)	1.56 (388)

POWER EXHAUST FANS PERFORMANCE

Return Air System Static Pressure		Air Volume Exhausted	
in. w.g.	Pa	cfm	m ³ /s
0	0	10 700	5.05
0.05	12	10 265	4.85
0.10	25	9585	4.50
0.15	37	9000	4.25
0.20	50	8250	4.90
0.25	62	7500	3.55
0.30	75	6585	3.10
0.35	87	5625	2.65
0.40	100	5440	2.55
0.45	112	3460	1.65
0.50	125	2915	1.40

CEILING DIFFUSER AIR THROW DATA

Model No.	Air Volume		*Effective Throw Range			
			LARTD30/36 Step-Down		LAFD30/36 Flush	
	cfm	m ³ /s	ft.	m	ft.	m
300 Models 360 Models	9000	4.25	40 - 47	12 - 14	29 - 35	8 - 11
	9500	4.50	43 - 50	13 - 15	33 - 41	10 - 12
	10 000	4.70	46 - 54	14 - 16	37 - 46	11 - 14
	10 500	4.95	50 - 58	15 - 18	42 - 51	13 - 15
	11 000	5.20	53 - 61	16 - 19	46 - 56	14 - 17
	11 500	5.45	55 - 64	17 - 20	50 - 61	15 - 19
	12 000	5.65	58 - 67	18 - 20	54 - 66	16 - 20
	12 500	5.90	61 - 71	19 - 22	58 - 71	18 - 22
	13 000	6.15	64 - 74	20 - 23	62 - 75	19 - 23
	13 500	6.35	67 - 77	20 - 23	66 - 79	20 - 24

*Throw is the horizontal or vertical distance an airstream travels on leaving the outlet or diffuser before the maximum velocity is reduced to 50 ft. (15 m) per minute. Four sides open.

Prepared for the guidance of architects, consulting engineers and mechanical contractors.

General — Furnish and install a single package air to air direct expansion mechanical cooling system, complete with automatic controls. The single package unit shall be a standard product of a firm regularly engaged in the manufacture of heating-cooling equipment.

The installed weight shall not be more than lbs. (kg). Entire unit shall have a width of not more than inches (mm), a depth of not more than inches (mm) and an overall height of not more than inches (mm). The equipment shall be shipped completely factory assembled, precharged, piped and wired internally ready for field connections. In addition, manufacturer shall test operate system at the factory before shipment.

Air Distribution — Equipment shall be capable of bottom (down-flo) or side (horizontal) handling of conditioned air. Horizontal air shall require optional horizontal roof mounting frame. All air distribution ducts shall be fiberglass or ga. galvanized steel insulated with inch (mm) thick lb./ft.³ (kg/m³) density fiberglass or equivalent.

Cooling System — The total cooling capacity shall not be less than Btuh (kW) with an evaporator air volume of cfm (m³/s), an entering wet bulb air temperature of °F (°C), an entering dry bulb air temperature of °F (°C) and a condenser entering temperature of °F (°C). The compressor power input shall not exceed kW at these conditions.

The coils shall be non-ferrous construction with aluminum fins mechanically bonded to durable copper tubes. Coils shall be pressure leak tested. Coil face area shall be not less than sq. ft. (m²) (evaporator) and sq. ft. (m²) (condenser). Condenser coils shall be slab coil construction.

Multiple compressors shall be resiliently mounted, have overload protection and crankcase heaters. The refrigeration system shall have discharge suction and liquid line gauge ports, high pressure switches, low pressure switches, driers, freezestats and full refrigerant charge. Service valves shall be standard on LCA360 models (optional for LCA300 models). All models shall have low ambient operation down to 0°F (-17.7°C).

Cabinet — Shall be galvanized steel with a powdered enamel paint finish electrostatically bonded to the metal. Cabinet panels where conditioned air is handled shall be fully insulated to prevent sweating and minimize sound. Openings shall be provided for power connection entry. Evaporator coil condensate drain extended outside cabinet shall be provided. Lifting holes shall be provided for rigging. Bottom power entry shall be furnished.

Service Access — Cabinet panels shall be hinged with tool-less access for compressor/heating/controls, blower and air filter/economizer compartments.

Supply Air Blowers — Centrifugal supply air blower shall have ball bearings and adjustable belt drive. Blower assembly shall slide out of unit for servicing. Motor mount base shall permit ease of motor changeover and belt tension adjustment. Blower wheel shall be statically and dynamically balanced. Blower shall be capable of delivering cfm (m³/s) at an external static pressure of inches water gauge (Pa) requiring bhp (W) and rev/min.

Condenser Fans — Direct drive propeller type condenser fans shall discharge vertically and be direct driven by a hp (W) motor. Fan motor shall have ball bearings and be permanently lubricated and inherently protected. Fans shall have a safety guard.

Air Filters — Disposable 2 inch (51 mm) thick pleated filters furnished shall have not less than sq. ft. (m²) of free area.

OPTIONAL ACCESSORIES

Additive Electric Heaters — The certified total heating capacity output shall be Btuh with kW input at volts power supply.

Electric heaters shall be available for factory or field installation. Heating elements shall be nichrome bare wire exposed directly to the air stream. Time delays shall bring the elements on and off in sequence with a time delay between each element. Limit controls shall provide overload and short circuit protection. Optional heater control module shall be required on 45, 60, 90 & 120 kW models. Optional fuse block, terminal block and wiring harness shall be required on all models.

Roof Mounting Frame — Furnish and install a steel roof mounting frame for bottom discharge and return air duct connection. It shall mate to the bottom perimeter of the equipment. When flashed into the roof it shall make a unit mounting curb and provide weatherproof duct connection and entry into the conditioned area. Height of frame shall be inches (mm). Flashing shall be the responsibility of the roofing contractor.

Horizontal Roof Mounting Frame — Furnish and install a steel roof mounting frame for side discharge and unit return air duct connection. It shall mate to the bottom perimeter of the equipment. When flashed into the roof it shall make a unit mounting curb and provide weatherproof duct connection and entry into the conditioned area. Flashing shall be the responsibility of the roofing contractor. Optional horizontal return air panel kit shall be required.

Economizer Section — Furnish and install economizer complete with recirculated air dampers, outside air dampers and controls. Low leakage dampers shall ride in nylon bearings. The economizer section shall provide for the introduction of outdoor air for minimum ventilation and free cooling. Integrated economizer control shall allow compressors to cycle for dehumidification and additional cooling, as needed, with up to 100% outdoor air intake. Damper actuator shall be opposing gear driven, 24 volt, fully modulating design. Plug-in control board (on unit IMC board) shall consist of adjustable minimum positioner, enthalpy setpoint and DIP switches for setting type of control logic used. Enthalpy control options shall consist of sensible temperature, global, outdoor enthalpy and differential enthalpy (outdoor and return air). Optional outdoor air hood (required) with filters shall be galvanized steel with a powdered enamel paint finish electrostatically bonded to the metal. Economizer shall be available for factory or field installation.

Gravity Exhaust Dampers — Pressure operated dampers shall be available for factory or field installation. Extruded aluminum dampers shall prevent blow-back and outdoor air infiltration during off cycle.

Power Exhaust Fans — Shall be available for all models with economizer (down-flow applications only). Direct drive propeller type fans shall exhaust air through optional gravity exhaust dampers (required). Motors shall be overload protected. Fans shall be factory or field installed in-between economizer and gravity exhaust dampers.

Horizontal Gravity Exhaust Dampers — Pressure operated dampers shall be available for field installation in the return air duct. Extruded aluminum dampers shall prevent blow-back and outdoor air infiltration during off cycle.

Outdoor Air Damper Section — Optional outdoor dampers shall be available to provide outdoor air requirements of up to 25%. Models shall be available for manual or automatic operation. Dampers shall be opposing gear driven design. Damper section shall install internal to the unit. Optional outdoor air hood (required) with filters shall be galvanized steel with a powdered enamel paint finish electrostatically bonded to the metal. Dampers shall be available for factory or field installation.

Ceiling Diffusers — Furnish and install a (flush or stepdown) optional combination ceiling supply and return air diffuser. It shall be capable of not less than ft. (m) radius of effective throw. Supply and return transitions shall be available, for field installation in the roof mounting frame, to provide duct connection to the diffuser.

Control Systems — Shall provide a selection of control systems to automatically operate the mechanical equipment through the heating or cooling and ventilating cycles as required.

Dirty Filter Switch — Furnish and install pressure switch that indicates dirty filter, relays information to Integrated Modular Control.

Blower Proving Switch — Furnish and factory install air pressure switch to monitor blower operation.

Disconnect — Furnish and factory install unit disconnect switch.

Indoor Air Quality Sensor — Furnish and field install sensor to monitor CO₂ levels, relays information to Integrated Modular Control which adjusts economizer dampers proportionately to the pollutant level.

Service Valves (LCA300 Models) — Furnish and factory install fully serviceable brass service valves in discharge and liquid lines. Shall allow refrigerant pump down to high side of system for servicing of low side.

Smoke Detectors — Furnish and factory install photoelectric type smoke detector in either or both return air section and supply air section.

Corrosion Protection — Furnish and factory apply phenolic epoxy coating to either or both of the following:

Condenser coils with painted condenser base section. Evaporator coil with painted evaporator base section and painted blower housings.

Prepared for the guidance of architects, consulting engineers and mechanical contractors.

General — Furnish and install a single package air to air direct expansion mechanical cooling system and gas fired heating system, complete with automatic controls. The single package unit shall be a standard product of a firm regularly engaged in the manufacture of heating-cooling equipment.

The installed weight shall not be more than lbs. (kg). Entire unit shall have a width of not more than inches (mm), a depth of not more than inches (mm) and an overall height of not more than inches (mm). The equipment shall be shipped completely factory assembled, precharged, piped and wired internally ready for field connections. In addition, manufacturer shall test operate system at the factory before shipment.

Air Distribution — Equipment shall be capable of bottom (down-flow) or side (horizontal) handling of conditioned air. Horizontal air shall require optional horizontal roof mounting frame. All air distribution ducts shall be fiberglass or ga. galvanized steel insulated with inch (mm) thick lb./ft.³ (kg/m³) density fiberglass or equivalent.

Cooling System — The total cooling capacity shall not be less than Btuh (kW) with an evaporator air volume of cfm (m³/s), an entering wet bulb air temperature of °F (°C), an entering dry bulb air temperature of °F (°C) and a condenser entering temperature of °F (°C). The compressor power input shall not exceed kW at these conditions.

The coils shall be non-ferrous construction with aluminum fins mechanically bonded to durable copper tubes. Coils shall be pressure leak tested. Coil face area shall be not less than sq. ft. (m²) (evaporator) and sq. ft. (m²) (condenser). Condenser coils shall be slab coil construction.

Multiple compressors shall be resiliently mounted, have overload protection and crankcase heaters. The refrigeration system shall have discharge suction and liquid line gauge ports, high pressure switches, low pressure switches, driers, freezestats and full refrigerant charge. Service valves shall be standard on LGA360 models (optional for LGA300 models). All models shall have low ambient operation down to 0°F (-17.7°C).

Heating System — The heating capacity output shall be Btuh (kW) with a gas input of Btuh (kW).

Tubular heat exchanger and inshot type gas burners shall be constructed of aluminized steel. Controls shall consist of direct spark ignition, electronic flame sensor controls, flame rollout switch, limit controls and automatic redundant dual gas valve with staging control and combustion air proving switch on induced draft blower. Unit shall be available for use with LPG/propane as an option. Heat exchanger shall be removable for servicing. Complete service access shall be provided for controls and wiring.

Cabinet — Shall be galvanized steel with a powdered enamel paint finish electrostatically bonded to the metal. Cabinet panels where conditioned air is handled shall be fully insulated to prevent sweating and minimize sound. Openings shall be provided for power connection entry. Evaporator coil condensate drain extended outside cabinet shall be provided. Lifting holes shall be provided for rigging. Bottom power electrical/gas entry shall be furnished.

Service Access — Cabinet panels shall be hinged with tool-less access for compressor/heating/controls, blower and air filter/economizer compartments.

Supply Air Blowers — Centrifugal supply air blower shall have ball bearings and adjustable belt drive. Blower assembly shall slide out of unit for servicing. Motor mount base shall permit ease of motor changeover and belt tension adjustment. Blower wheel shall be statically and dynamically balanced. Blower shall be capable of delivering cfm (m³/s) at an external static pressure of inches water gauge (Pa) requiring bhp (W) and rpm.

Condenser Fans — Direct drive propeller type condenser fans shall discharge vertically and be direct driven by a hp (W) motor. Fan motor shall have ball bearings and be permanently lubricated and inherently protected. Fans shall have a safety guard.

Air Filters — Disposable 2 inch (51 mm) thick pleated filters furnished shall have not less than sq. ft. (m²) of free area.

OPTIONAL ACCESSORIES

Roof Mounting Frame — Furnish and install a steel roof mounting frame for bottom discharge and return air duct connection. It shall mate to the bottom perimeter of the equipment. When flashed into the roof it shall make a unit mounting curb and provide weatherproof duct connection and entry into the conditioned area. Height of frame shall be inches (mm). Flashing shall be the responsibility of the roofing contractor.

Horizontal Roof Mounting Frame — Furnish and install a steel roof mounting frame for side discharge and unit return air duct connection. It shall mate to the bottom perimeter of the equipment. When flashed into the roof it shall make a unit mounting curb and provide weatherproof duct connection and entry into the conditioned area. Flashing shall be the responsibility of the roofing contractor. Optional horizontal return air panel kit shall be required.

Economizer Section — Furnish and install economizer complete with recirculated air dampers, outside air dampers and controls. Low leakage dampers shall ride in nylon bearings. The economizer section shall provide for the introduction of outdoor air for minimum ventilation and free cooling. Integrated economizer control shall allow compressors to cycle for dehumidification and additional cooling, as needed, with up to 100% outdoor air intake. Damper actuator shall be opposing gear driven, 24 volt, fully modulating design. Plug-in control board (on unit IMC board) shall consist of adjustable minimum positioner, enthalpy setpoint and DIP switches for setting type of control logic used. Enthalpy control options shall consist of sensible temperature, global, outdoor enthalpy and differential enthalpy (outdoor and return air). Optional outdoor air hood (required) with filters shall be galvanized steel with a powdered enamel paint finish electrostatically bonded to the metal. Economizer shall be available for factory or field installation.

Gravity Exhaust Dampers — Pressure operated dampers shall be available for factory or field installation. Extruded aluminum dampers shall prevent blow-back and outdoor air infiltration during off cycle.

Power Exhaust Fans — Shall be available for all models with economizer (down-flow applications only). Direct drive propeller type fans shall exhaust air through optional gravity exhaust dampers (required). Motors shall be overload protected. Fans shall be factory or field installed in-between economizer and gravity exhaust dampers.

Horizontal Gravity Exhaust Dampers — Pressure operated dampers shall be available for field installation in the return air duct. Extruded aluminum dampers shall prevent blow-back and outdoor air infiltration during off cycle.

Outdoor Air Damper Section — Optional outdoor dampers shall be available to provide outdoor air requirements of up to 25%. Models shall be available for manual or automatic operation. Dampers shall be opposing gear driven design. Damper section shall install internal to the unit. Optional outdoor air hood (required) with filters shall be galvanized steel with a powdered enamel paint finish electrostatically bonded to the metal. Dampers shall be available for factory or field installation.

Ceiling Diffusers — Furnish and install a (flush or stepdown) optional combination ceiling supply and return air diffuser. It shall be capable of not less than ft. (m) radius of effective throw. Supply and return transitions shall be available, for field installation in the roof mounting frame, to provide duct connection to the diffuser.

Control Systems — Shall provide a selection of control systems to automatically operate the mechanical equipment through the heating or cooling and ventilating cycles as required.

Dirty Filter Switch — Furnish and install pressure switch that indicates dirty filter, relays information to Integrated Modular Control.

Blower Proving Switch — Furnish and factory install air pressure switch to monitor blower operation.

Disconnect — Furnish and factory install unit disconnect switch.

Indoor Air Quality Sensor — Furnish and field install sensor to monitor CO₂ levels, relays information to Integrated Modular Control which adjusts economizer dampers proportionately to the pollutant level.

Service Valves — Furnish and factory install fully serviceable brass service valves in discharge and liquid lines. Shall allow refrigerant pump down to high side of system for servicing of low side.

Smoke Detectors — Furnish and factory install photoelectric type smoke detector in return air section and supply air section.

Corrosion Protection — Furnish and factory apply phenolic epoxy coating to either or both of the following:
Condenser coils with painted condenser base section. Evaporator coil with painted evaporator base section and painted blower housings.

**LCA300 & 360 UNITS SHOWN WITH
OPTIONAL ECONOMIZER DAMPERS, POWER EXHAUST FANS, CONVENIENCE OUTLET, UNIT DISCONNECT**

CORNER WEIGHTS — lbs. (kg)

Model Number	AA		BB		CC		DD	
	lbs.	kg	lbs.	kg	lbs.	kg	lbs.	kg
LCA300 Base Unit	569	258	626	284	899	408	816	370
LCA300 Max. Unit	713	323	732	332	929	421	906	411
LCA360 Base Unit	637	289	636	288	972	441	975	442
LCA360 Max. Unit	780	354	738	335	1001	454	1061	481

Base Unit — The standard unit with NO OPTIONS.
Max. Unit — The standard unit with ALL OPTIONS Installed. (Economizer, Power Exhaust Fans, High Input Heating and Controls)

CENTER OF GRAVITY — inches (mm)

Model Number	EE		FF	
	inch	mm	inch	mm
LCA300 Base Unit	63-3/8	1610	37-1/4	946
LCA300 Max. Unit	61-1/4	1556	40-1/8	1019
LCA360 Base Unit	60-3/8	1534	36	914
LCA360 Max. Unit	58-7/8	1495	38-5/8	981

Base Unit — The standard unit with NO OPTIONS.
Max. Unit — The standard unit with ALL OPTIONS Installed. (Economizer, Power Exhaust Fans, High Input Heating and Controls)

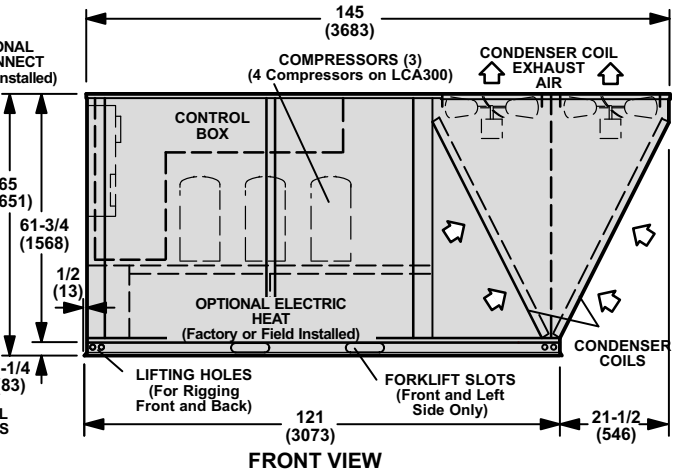
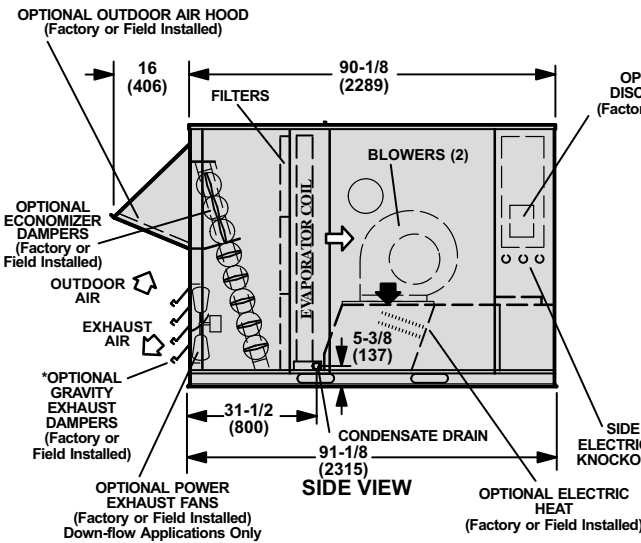
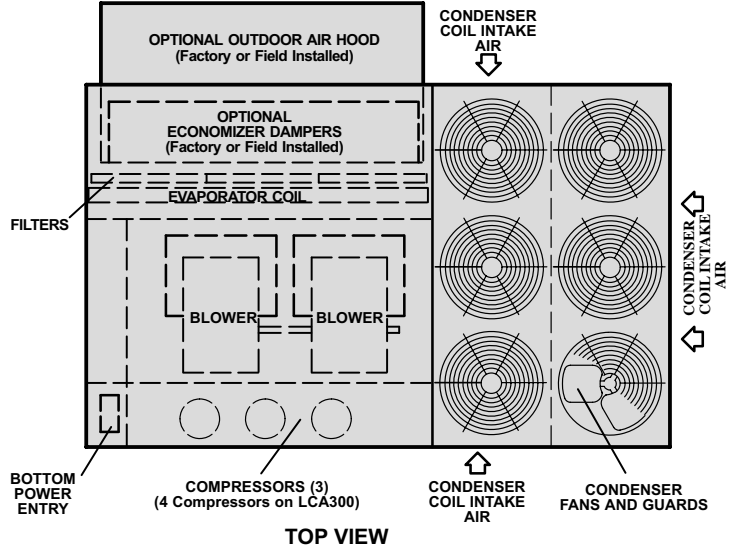
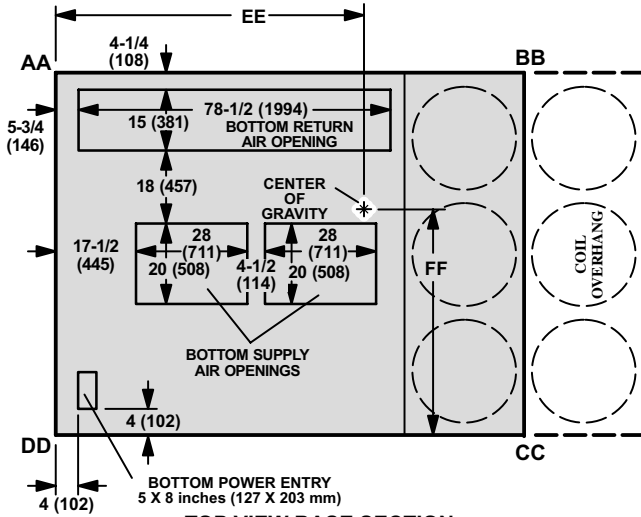

*NOTE — Field Installed in Return Air Duct for Horizontal Applications.

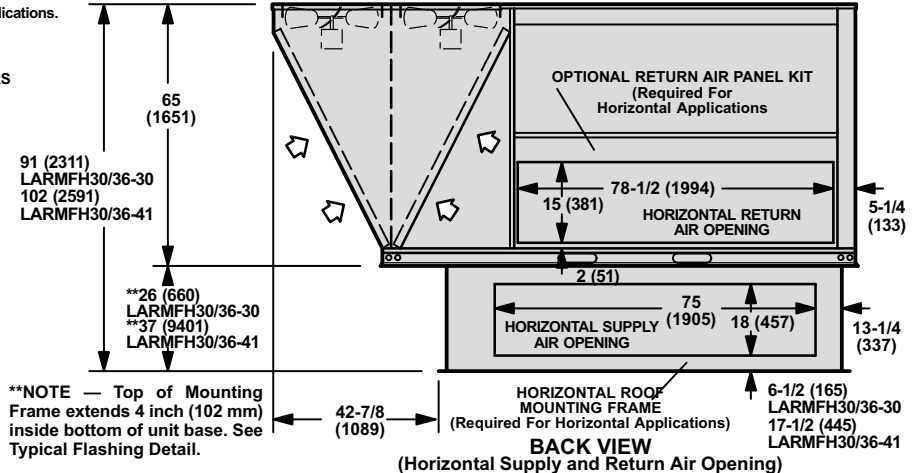
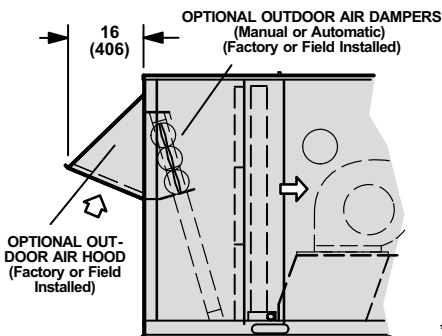

**NOTE — Top of Mounting Frame extends 4 inch (102 mm) inside bottom of unit base. See Typical Flashing Detail.

**LGA300 & 360 UNITS SHOWN WITH
OPTIONAL ECONOMIZER DAMPERS, POWER EXHAUST FANS, CONVENIENCE OUTLET, UNIT DISCONNECT**

3CORNER WEIGHTS — lbs. (kg)

Model Number	AA		BB		CC		DD	
	lbs.	kg	lbs.	kg	lbs.	kg	lbs.	kg
LGA300 Base Unit	588	267	630	286	932	423	870	395
LGA300 Max. Unit	716	325	743	337	958	335	923	419
LGA360 Base Unit	656	298	639	290	1004	455	1031	468
LGA360 Max. Unit	785	356	740	336	1025	465	1090	494

CENTER OF GRAVITY — inches (mm)

Model Number	EE		FF	
	inch	mm	inch	mm
LGA300 Base Unit	62-5/8	1591	36-3/4	933
LGA300 Max. Unit	61-1/4	1556	39-3/4	1010
LGA360 Base Unit	59-3/4	1518	35-3/8	899
LGA360 Max. Unit	58-7/8	1495	38-1/4	972

Base Unit — The standard unit with NO OPTIONS.
Max. Unit — The standard unit with ALL OPTIONS installed. (Economizer, Power Exhaust Fans, High Input Heating and Controls)

Base Unit — The standard unit with NO OPTIONS.
Max. Unit — The standard unit with ALL OPTIONS installed. (Economizer, Power Exhaust Fans, High Input Heating and Controls)

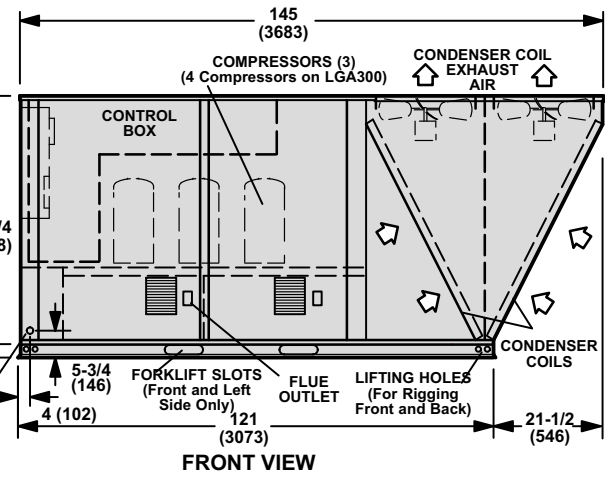
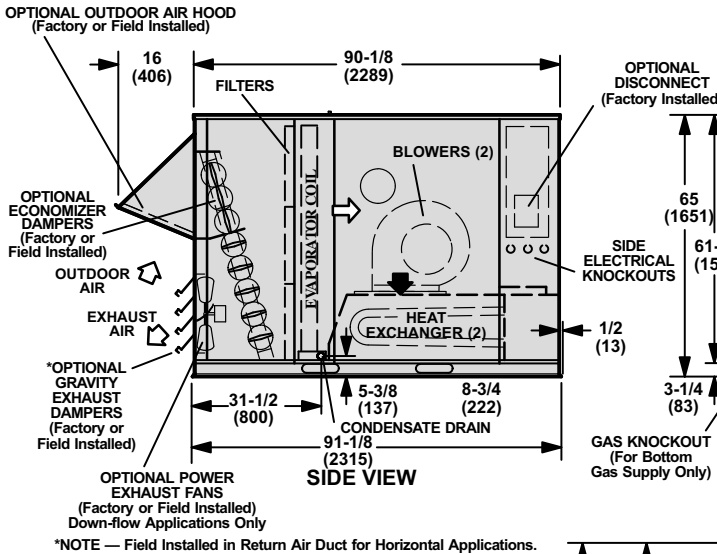
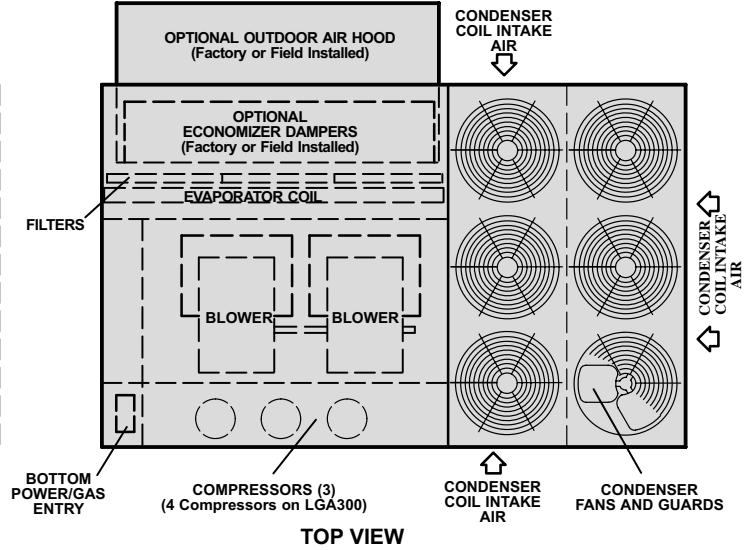
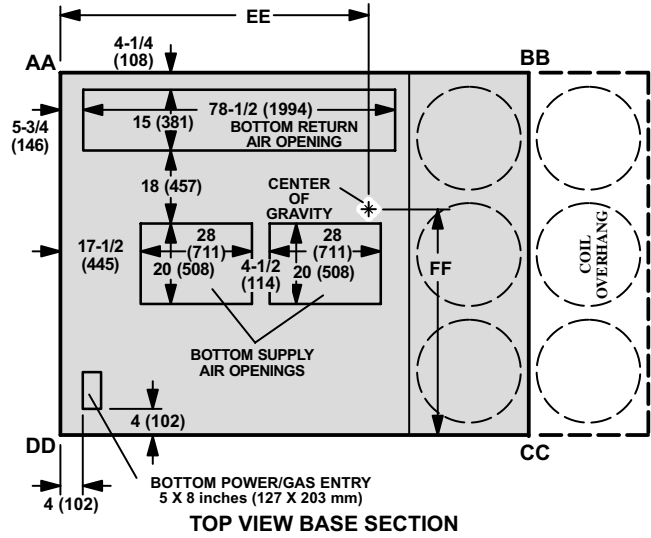

*NOTE — Field Installed in Return Air Duct for Horizontal Applications.

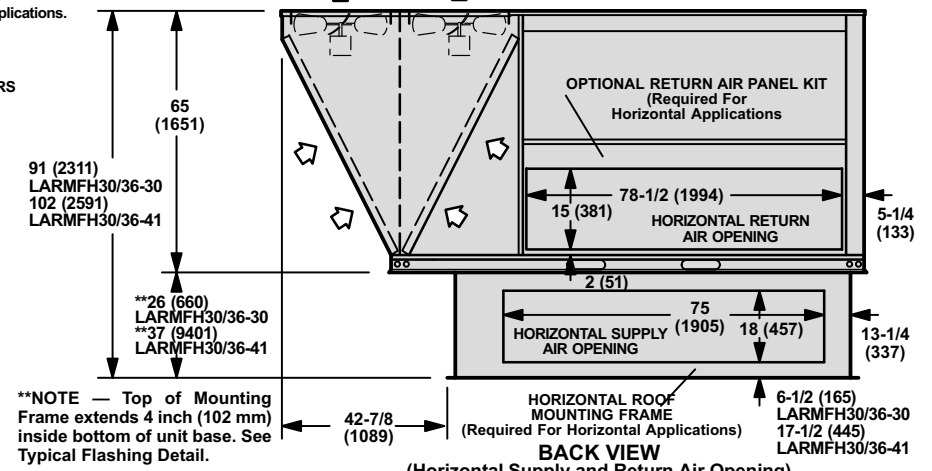
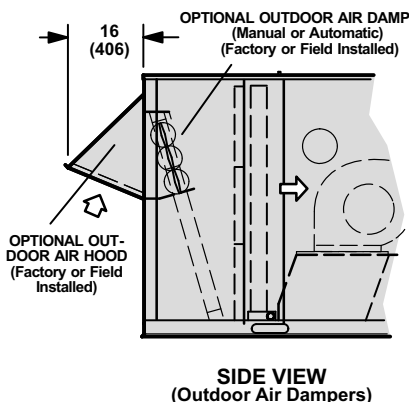

**NOTE — Top of Mounting Frame extends 4 inch (102 mm) inside bottom of unit base. See Typical Flashing Detail.

LARMF18/36-14 AND LARMF18/36-24 ROOF MOUNTING FRAMES WITH DOUBLE DUCT OPENING FOR -300 & -360 UNITS

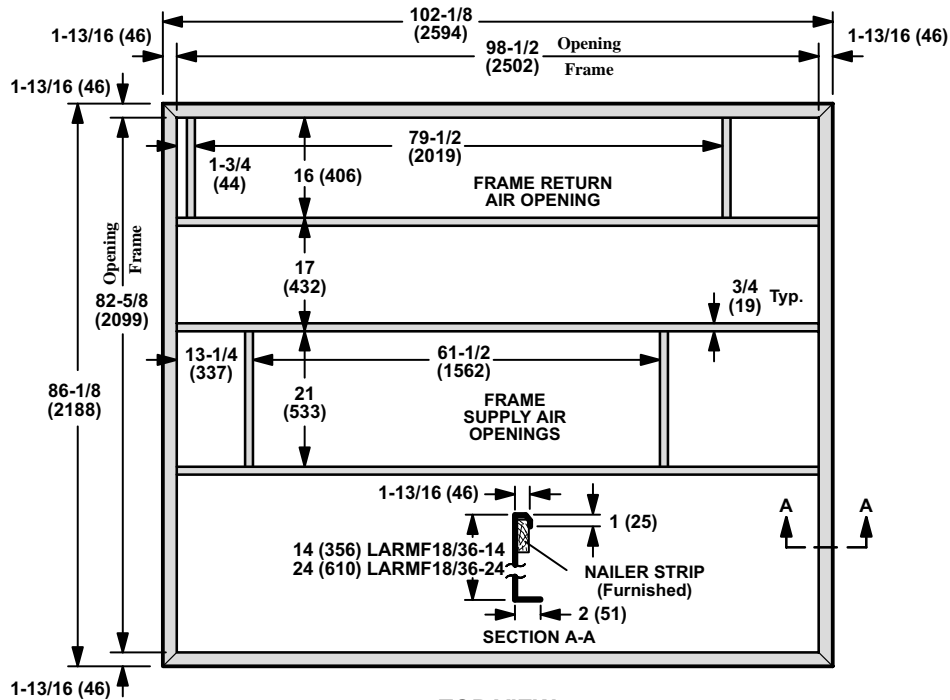

TOP VIEW

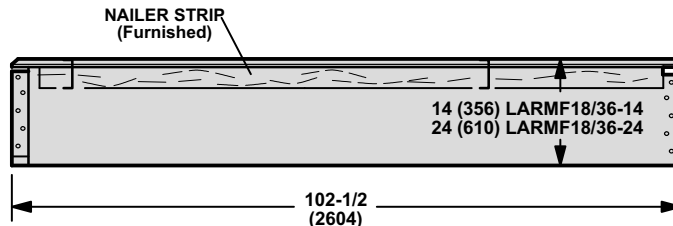

SIDE VIEW

NOTE — Roof deck may be omitted within confines of frame.

ROOF MOUNTING FRAME SPECIFICATIONS

Roof Mounting frame is rigid enough to be spanned over its entire length or cantilevered if supported on both sides of center of gravity.

Roof Mounting Frame	LARMF18/36-14	LARMF18/36-24
*Moment of inertia (I) (in. ⁴) (cm ⁴)	39 (1634)	160 (6639)
*Section modulus $\frac{I}{C}$ (in. ³) (cm ³)	5.5 (90)	13.1 (512)
Frame weight. (lb/ft) (kg/m) of length	5.5 (8.2)	8.5 (12.7)
Design strength (psi) (kPa)	20,000 (137,900)	

*Includes both sides of frame.

TYPICAL FLASHING DETAIL FOR LARMF18/36 ROOF MOUNTING FRAMES

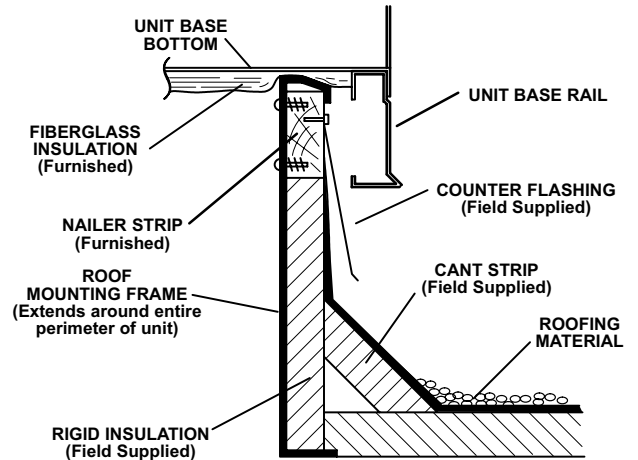

LARMF18/36-14 AND LARMF18/36-24 ROOF MOUNTING FRAMES WITH LASRT36 SUPPLY & RETURN AIR TRANSITIONS FOR LARTD26 & LAFD36 CEILING DIFFUSERS

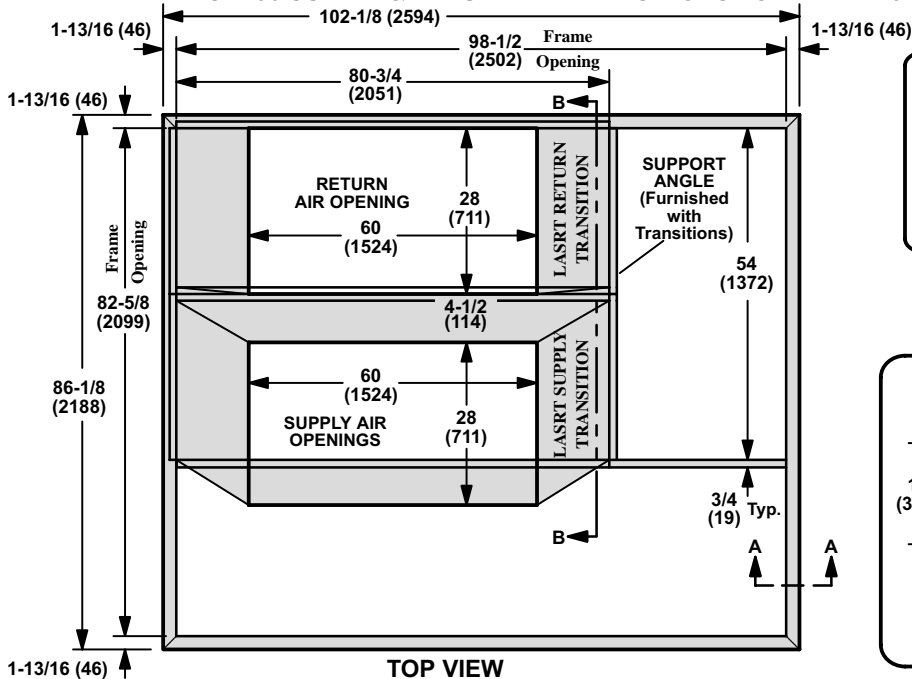

ROOF MOUNTING FRAME DETAIL

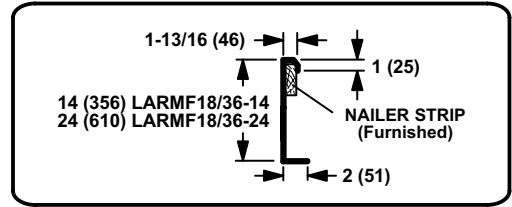

SECTION A-A

TRANSITION DETAIL

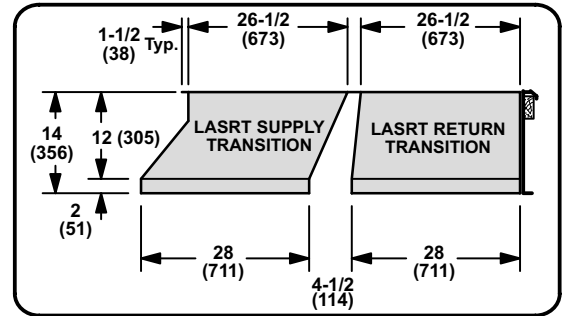

SECTION B-B

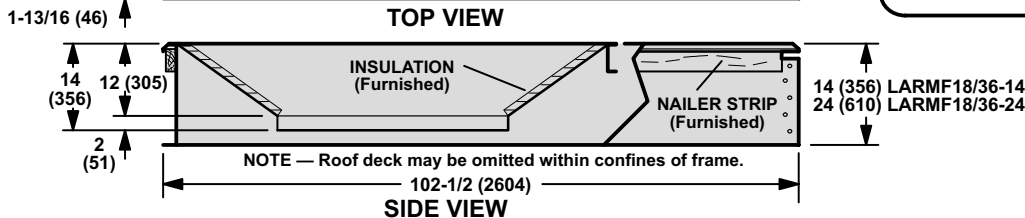

SIDE VIEW

LARMFH30/36-30 AND LARMFH30/36-41 HORIZONTAL ROOF MOUNTING FRAMES

NOTE — Requires Optional Horizontal Return Air Panel Kit

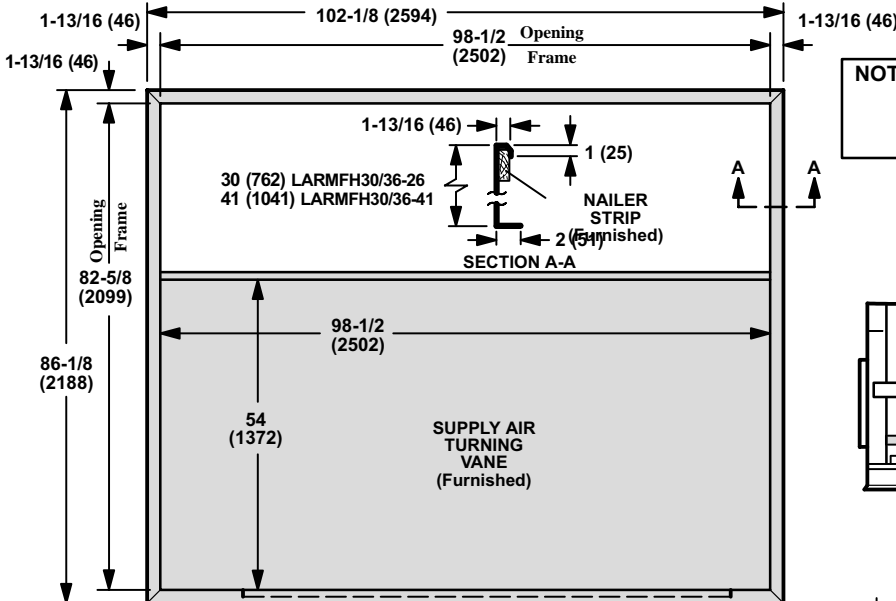

NOTE - LARMFH30/36-30 is designed for horizontal discharge when unit is mounted on a slab. LARMFH30/36-41 is designed for horizontal discharge when unit is mounted on a rooftop.

SECTION A-A

PANEL TO COVER RETURN AIR OPENING IN BOTTOM OF UNIT (Furnished With Optional Horizontal Return Air Panel Kit)

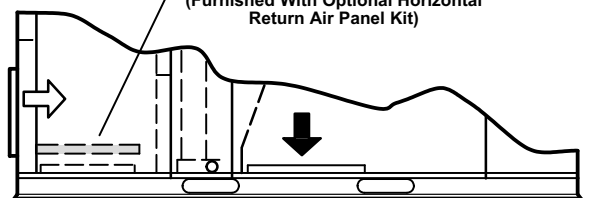

SIDE VIEW (PACKAGED UNIT)

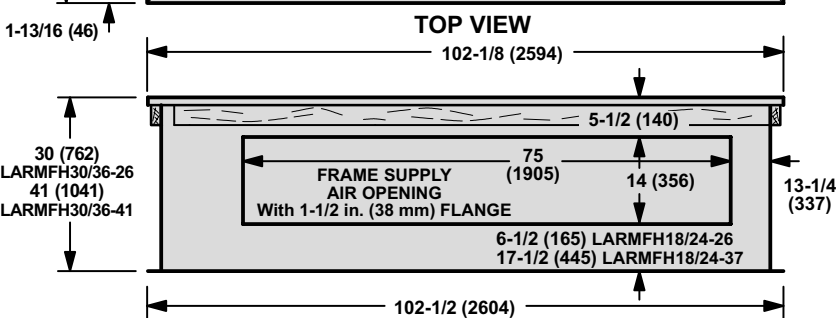

FRONT VIEW

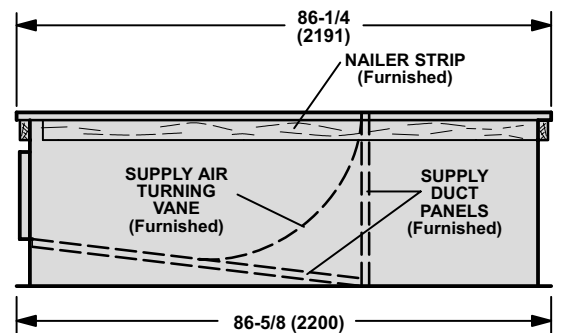

SIDE VIEW

NOTE — Roof deck may be omitted within confines of frame.

COMBINATION CEILING SUPPLY AND RETURN DIFFUSERS

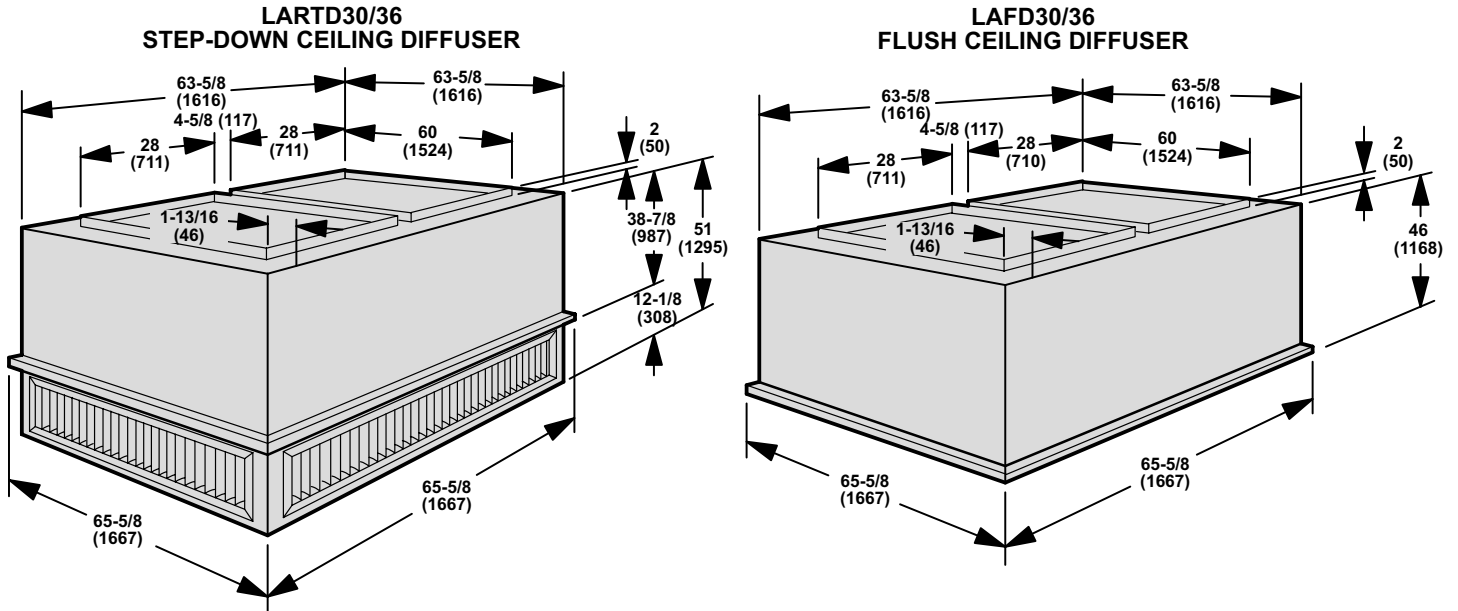

LAGEDH30/36 HORIZONTAL GRAVITY EXHAUST DAMPERS
(Two Furnished Per Order No.)
Field Installed In Return Air Duct

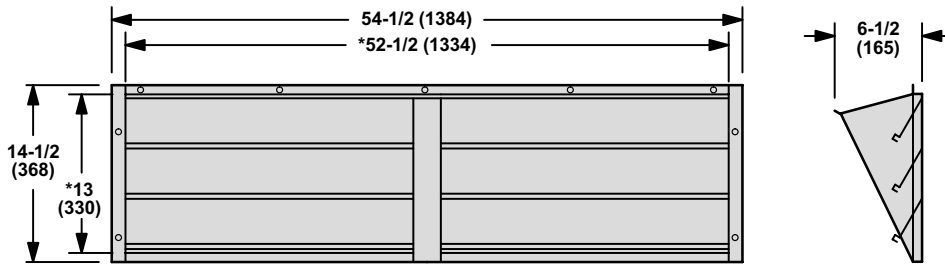

*NOTE — Opening size required in return air duct.

FRONT VIEW

SIDE VIEW

UNIT WITH ECONOMIZER

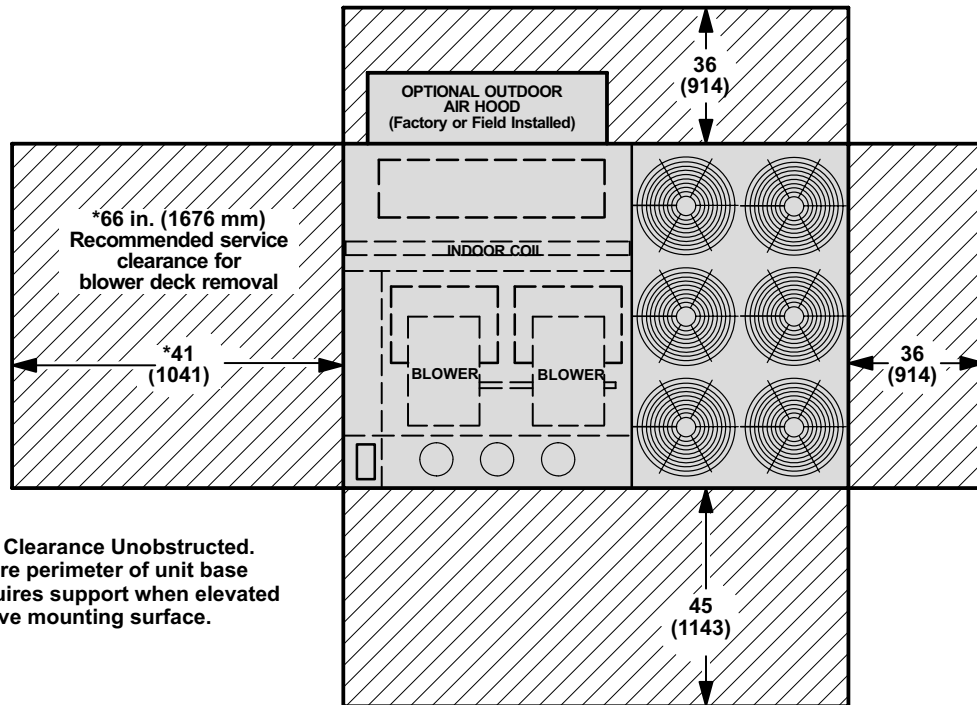

NOTE — Top Clearance Unobstructed.
 NOTE — Entire perimeter of unit base requires support when elevated above mounting surface.

UNIT WITH HORIZONTAL GRAVITY EXHAUST DAMPERS

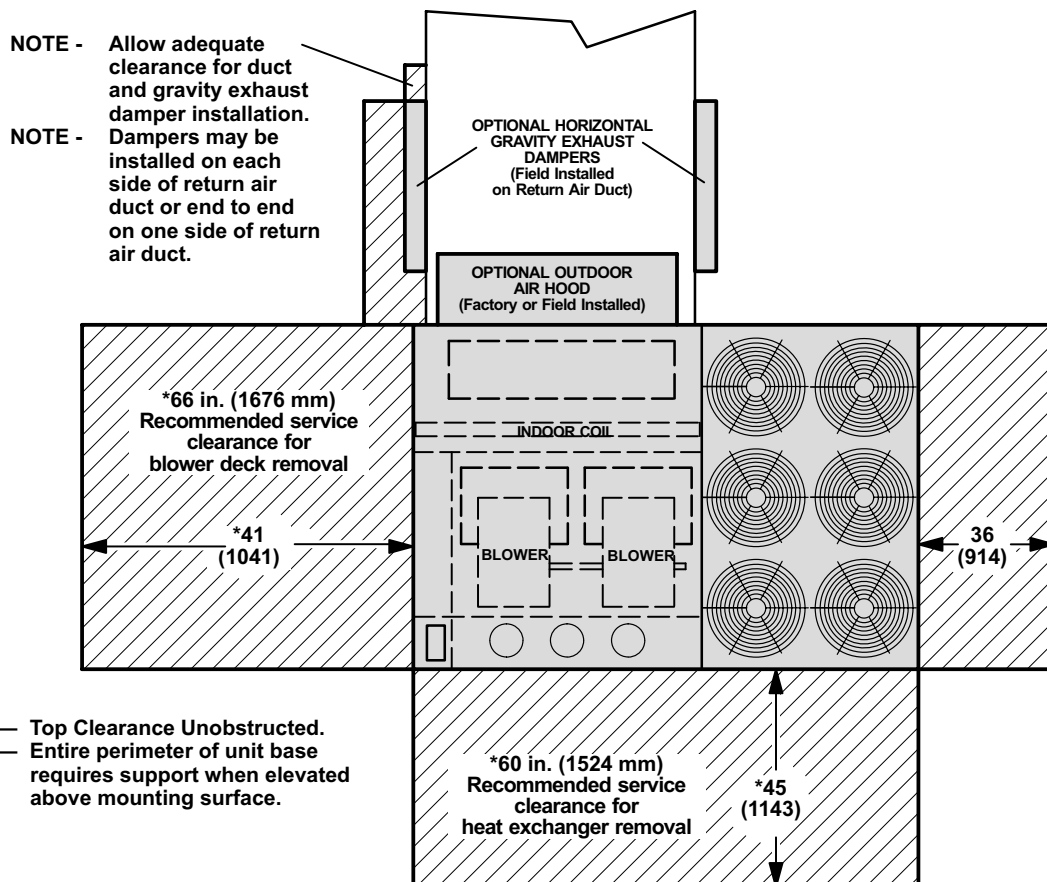

NOTE — Top Clearance Unobstructed.
 NOTE — Entire perimeter of unit base requires support when elevated above mounting surface.