

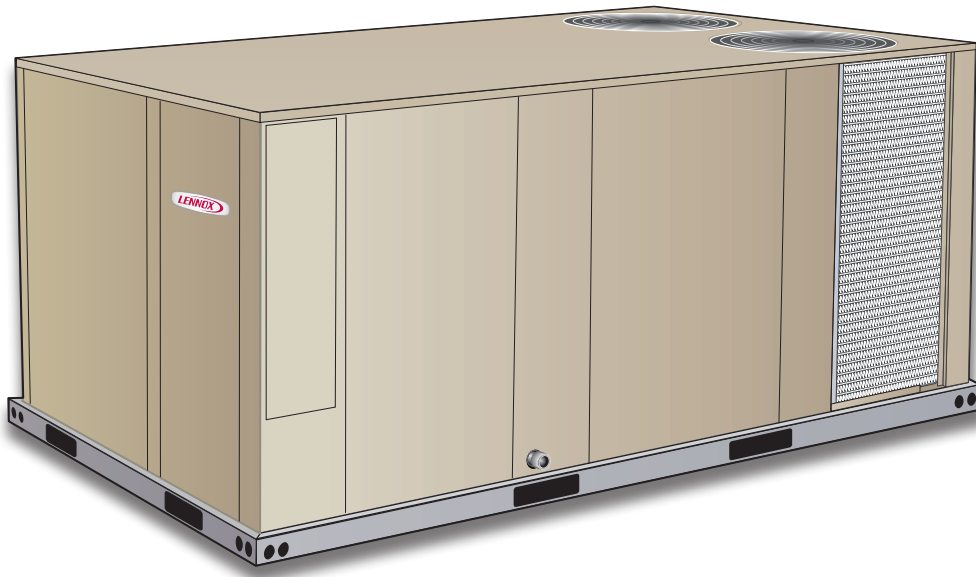

COMMERCIAL
PRODUCT SPECIFICATIONS

Bulletin No. 490172
 March 2020
 Supersedes February 2020



LANDMARK®
 Performance Marked by Flexibility™



26 to 44 kW (7.5 to 12.5 Ton)
Net Cooling Capacity - 22.4 to 36.7 kW (74 500 to 123 300 Btuh)
Optional Electric Heat - 5.7 to 45.9 kW

MODEL NUMBER IDENTIFICATION

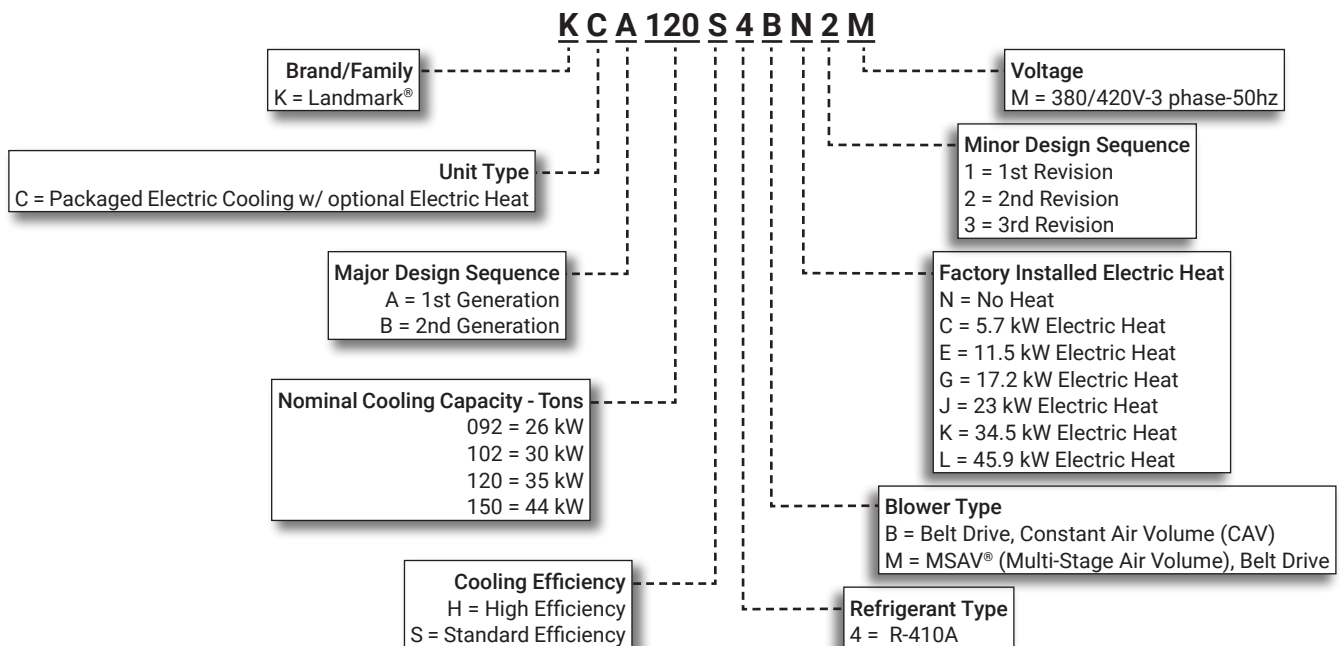

FEATURE HIGHLIGHTS

Landmark® rooftop units from Lennox are the new standard for reliable, efficient rooftop units built for long-lasting performance that can significantly improve indoor environments.

1. Scroll Compressors
2. Lennox' Environ™ Coil System
3. Outdoor Coil Fan Motors
4. Heavy Gauge Steel Cabinet
5. Constant or Multi-Stage Air Volume (MSAV®) Blower
6. Unit Control
7. Electric Heat (option)
8. Air Filters
9. Economizer (option)
10. Downflow Barometric Relief Dampers (option)

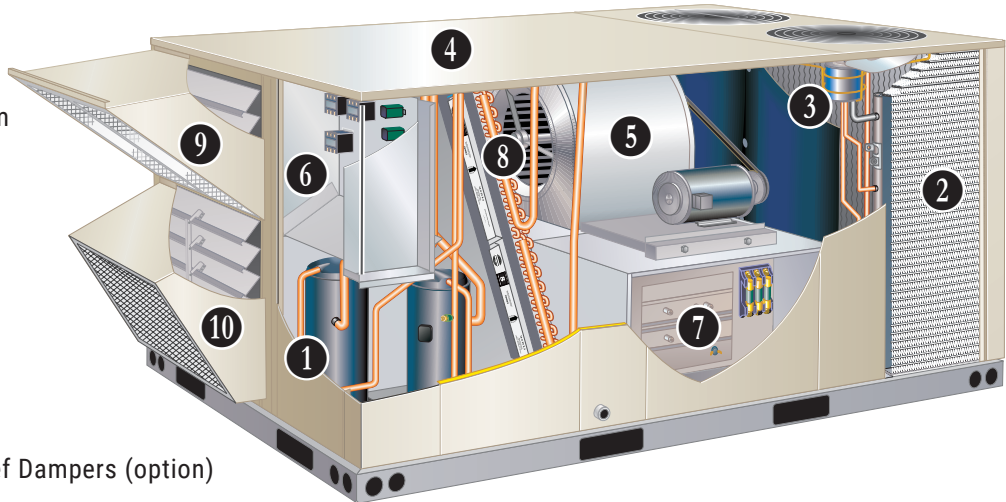

CONTENTS

Approvals	3
Blower Data	29
Dimensions - Accessories	40
Dimensions - Unit	39
Electrical/Electric Heat Data	35
Electric Heat Capacities	36
Features And Benefits	3
Model Number Identification.	1
Optional Conventional Temperature Control Systems	10
Options / Accessories	11
Outdoor Sound Data	37
Ratings - High Efficiency	25
Ratings - Standard Efficiency	18
Specifications	14
Unit Clearances	37
Weight Data	38

APPROVALS

PERFORMANCE / QUALITY

- Components bonded for grounding to meet safety standards for servicing required by Underwriters Laboratories (UL) and the International Electrotechnical Commission (IEC)
- Cooling performance is rated at test conditions included in Air-Conditioning, Heating and Refrigeration Institute (AHRI) Standard 340/360 while operating at rated voltage and air volumes
- International Organization for Standardization (ISO) 9001 Registered Manufacturing Quality System

FEATURES AND BENEFITS

COOLING SYSTEM

- Designed to maximize sensible and latent cooling performance at design conditions
- System can operate from 4°C to 52°C without any additional controls

R-410A Refrigerant

- Non-chlorine based
- Ozone friendly

1 Scroll Compressors

- Scroll compressors on all models for high performance, reliability and quiet operation
- Resiliently mounted on rubber grommets for quiet operation

Compressor Crankcase Heaters

- Protects against refrigerant migration that can occur during low ambient operation

Thermal Expansion Valves

(All High Efficiency Models, 150S Model)

- Assures optimal performance throughout the application range
- Removable element head

Refrigerant Metering Orifice

(092 through 120 Standard Efficiency Models)

- Accurately meters refrigerant in system
- Refrigerant control is accomplished by exact sizing of refrigerant metering orifice

Filter/Driers

- High capacity filter/drier protects the system from dirt and moisture

High Pressure Switches

- Protects the compressor from overload conditions such as dirty condenser coils, blocked refrigerant flow, or loss of outdoor fan operation
- Automatic reset

Freezestats

- Protects the evaporator coil from damaging ice build-up due to conditions such as low/no airflow, or low refrigerant charge

2 Condenser Coil - Lennox' Environ™ Coil System (092 through 120 models only)

- Lightweight, all aluminum brazed fin construction
- Constructed of three components
 - A flat extrusion tube
 - Fins in-between the flat extrusion tube
 - Two refrigerant manifolds

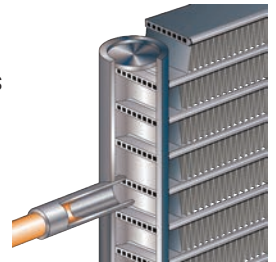

Environ™ Coil System Features:

- Improved heat transfer performance due to high primary surface area (flat tubes) versus secondary surface (fins)
- Smaller internal volume (reduced refrigerant charge)
- High durability
- All aluminum construction
- Fewer brazed joints
- Compact design
- Reduced unit weight
- Easy maintenance/cleaning
- Face split design
- Mounting brackets with rubber inserts

Conventional Fin/Tube Condenser Coils (150 models only, optional 092-120 models)

- Copper tube construction
- Enhanced rippled-edge aluminum fins
- Flared shoulder tubing connections
- Silver soldered construction

Evaporator Coil

- Copper tube construction
- Enhanced rippled-edge aluminum fins
- Flared shoulder tubing connections
- Silver soldered construction
- Factory leak tested
- Cross row circuiting with rifled tubing

Condensate Drain Pan

- Plastic pan, sloped to meet drainage requirements per ASHRAE 62.1
- Side or bottom drain connections
- Reversible to allow connection at back of unit

FEATURES AND BENEFITS

COOLING SYSTEM (continued)

- 3 Outdoor Coil Fan Motors**
- Thermal overload protected
 - Totally enclosed
 - Permanently lubricated ball bearings
 - Shaft up
 - Wire basket mount

Outdoor Coil Fans

- Polyvinyl Chloride (PVC) coated fan guard furnished

Required Selections

Cooling Capacity

- Specify nominal cooling capacity

Cooling Efficiency

- Specify either standard or high efficiency

Options/Accessories

Factory Installed

Conventional Fin/Tube Condenser Coil (replaces Environ™ Coil System - 092 through 120 models only)

- Copper tube construction
- Enhanced rippled-edge aluminum fins
- Flared shoulder tubing connections
- Silver soldered construction

Field Installed

Condensate Drain Trap

- Available in copper or polyvinyl chloride (PVC)

Drain Pan Overflow Switch

- Monitors condensate level in drain pan
- Shuts down unit if drain becomes clogged

Low Ambient Controls

- Units operate satisfactorily down to 7°C outdoor air temperature without any additional controls
- Two low ambient control options are available for field installation:
 1. **Low Ambient Control Kit (-1.1°C)** - Allows unit operation down to -1.1°C
 2. **Low Ambient Control Kit (-18°F)** - Allows unit operation down to -18°C without evaporator coil icing. Head pressure speed control reduces outdoor fan operation during low ambient conditions until head pressure rises to the setpoint. Pressure transducers are mounted on the liquid lines. High pressure switches are furnished to replace existing. Wiring harnesses are furnished for simple plug-in wiring to fans and controller.

CABINET

4 Construction

- Heavy-gauge steel panels
- Full perimeter heavy-gauge galvanized steel base rail
- Base rails have rigging holes
- Three sides of the base rail have forklift slots
- Raised edges around duct and power entry openings in the bottom of the unit for water protection

Airflow Choice

- Units are shipped in downflow (vertical) return air flow configuration

NOTE - Units can be field converted to horizontal airflow with optional Horizontal Discharge Kit.

Duct Flanges

- Provided for horizontal duct attachment

Power Entry

- Electrical lines can be brought through the unit base or through horizontal access knock-outs

Exterior Panels

- Constructed of heavy-gauge, galvanized steel
- Two-layer enamel paint finish

Insulation

- Fully insulated with non-hygroscopic fiberglass insulation (conditioned areas)
- Unit base is fully insulated
- Base insulation serves as an air seal to the roof curb, eliminating the need to add a seal during installation

Access Panels

- Filter section
- Blower/heating section
- Compressor/controls section

FEATURES AND BENEFITS

CABINET (continued)

Options/Accessories

Factory Installed

Corrosion Protection

- Completely flexible immersed coating
- Electrodeposited dry film process
- AST ElectroFin E-Coat
- Meets Mil Spec MIL-P-53084, ASTM B117 Standard Method Salt Spray Testing
- Indoor Corrosion Protection:
 - Coated coil
 - Painted blower housing
 - Painted base
- Outdoor Corrosion Protection:
 - Coated coil
 - Painted outdoor base

Hinged Access Panels

- Tool-less access
- Filter section
- Blower/heating section
- Compressor/controls section
- Panel seals and quarter-turn latching handles provide a tight air and water seal

Field Installed

Combination Coil/Hail Guards

- Heavy gauge steel frame
- Painted to match cabinet
- Expanded metal mesh protects outdoor coil

Horizontal Discharge Kit

- Consists of duct covers to block off downflow supply and return air openings for horizontal applications
- Also includes return air duct flanges for end return air when economizer is used in horizontal applications

NOTE - When configuring unit for horizontal application with economizer, a separate Horizontal Barometric Relief Damper with Hood must be ordered separately for installation in the return air duct.

Return Air Adaptor Plate

- For same size LC/LG/LH and TC/TG/TH unit replacement
- Installs on return air opening in unit to match return air opening on existing roof curbs
- Also see Accessory Air Resistance table

BLOWER

- A wide selection of supply air blower options are available to meet a variety of airflow requirements

Motor

- Overload protected
- Ball bearings
- Belt drive motors are offered on all models and are available in several different sizes to maximize air performance

5 Supply Air Blower

- Forward curved blades
- Double inlet
- Blower wheel statically and dynamically balanced
- Ball bearings
- Adjustable pulley (allows speed change)
- Blower assembly slides out of unit for servicing

Required Selections

Select Constant Air Volume (CAV) or MSAV® (Multi-Stage Air Volume) Blower Option

- Order blower motor horsepower and drive kit number required when base unit is ordered
- See Drive Kit Specifications Table

CAV Operation

- Supply air blower will provide a constant volume of air

MSAV Operation

- Units utilize a Variable Frequency Drive (VFD) to stage the supply air blower airflow
- The VFD alters the frequency and voltage of the power supply to the blower to control blower speed
- The supply air blower has two speeds:
 - Low speed for part-load cooling operation. Note - Low speed is 66% of high speed
 - High speed for full load cooling and all heat modes
- Full speed blower operation is set by adjusting the motor pulley to deliver the desired air volume
- The ventilation speed is selectable between high and low speed

NOTE - Part load airflow in cooling mode on MSAV units should not be set below 30 L/s per kW to reduce the risk of evaporator coil freeze-up.

- The VFD has an operational range of -40 to 52°C outdoor air ambient temperature
- Lower operating costs are obtained when the blower is operated on lower speeds

FEATURES AND BENEFITS

BLOWER (continued)

MSAV Sequence of Operation

- Ventilation speed is determined by the VENT SPEED switch setting on VFD control board (LO or HI)
- Blower operates in low speed for mechanical cooling (Y1)
- Blower operates in high speed for any other mode (free cooling, mechanical cooling Y1+Y2, and heating)
- Economizer damper minimum position is fully closed in unoccupied mode
- In occupied mode, the economizer damper minimum position is determined by the setting of the two potentiometers on VFD control board:
 - LO SPD MIN POS potentiometer sets the minimum position when blower is operating at low speed
 - HI SPD MIN POS potentiometer sets the minimum position when blower is operating at high speed

Options/Accessories

Field Installed

VFD Manual Bypass Kit

- VFD Manual Bypass Control is available as a kit for units equipped with the MSAV option
- The VFD Manual Bypass Control is a manual bypass and is enabled by re-configuring the wiring on the unit

CONTROLS

6 Unit Control

- All control voltage is provided via a 24V (secondary) transformer with built-in circuit breaker protection
- **Heat/Cool Staging** - Capable of up to 2 heat / 2 cool staging with a third party DDC control system or thermostat
- **Low Voltage Terminal Block** - Provides screw terminal connections for thermostat or controller wiring
- **Night Setback Mode** - Saves energy by closing outdoor air dampers and operating supply fan on thermostat demand only

Options/Accessories

Field Installed

Smoke Detector

- Photoelectric type
- Installed in supply air section, return air section or both sections
- Available with power board and single sensor (supply or return) or power board and two sensors (supply and return)

Commercial Control Systems

Thermostats

- Control system and thermostat options. Aftermarket unit controller options. See page 10

ELECTRICAL

Marked & Color-Coded Wiring

- All electrical wiring is color-coded and marked to identify which components it is connecting

Electrical Plugs

- Positive connection electrical plugs are used to connect common accessories or maintenance parts for easy removal or installation

Phase Monitor

(Factory Installed on Units Equipped with the MSAV® Supply Air Blower Option)

- Phase monitor located in the control compartment detects the phasing of incoming power
- If the incoming power is out of phase or if any of the three phases are lost, an indicator LED on the phase monitor will turn red and the unit will not start
- In normal operation with correct incoming power phasing, the LED will be green

Required Selections

Voltage Choice

- Specify when ordering base unit

Options/Accessories

Factory or Field Installed

7 Electric Heat

- Helix wound nichrome elements
- Individual element limit controls
- Wiring harness
- Unit fuse block
- See Options / Accessories tables for ordering information

NOTE - Factory installed electric heat is only available with high efficiency models.

FEATURES AND BENEFITS

INDOOR AIR QUALITY

8 Air Filters

- Disposable 51 mm filters furnished as standard

Options / Accessories

Field Installed

Healthy Climate® High Efficiency Air Filters

- Disposable MERV 8 or MERV 13 (Minimum Efficiency Reporting Value based on ASHRAE 52.2) efficiency 51 mm pleated filters

Replacement Filter Media Kit With Frame

- Replaces existing pleated filter media. Includes washable metal mesh screen and metal frame with clip for holding replaceable non-pleated filter

Healthy Climate® UVC Germicidal Lamps



- Germicidal lamps emit ultra-violet (UV-C) energy, which has been proven to be effective in reducing microbes such as viruses, bacteria, yeasts, and molds
- This process either destroys the organism or controls its ability to reproduce
- UV-C energy greatly reduces the growth and proliferation of mold and other bioaerosols (bacteria and viruses) on illuminated surfaces (particularly coil and drain pan)
- Lamps are field installed in the blower/evaporator coil section
- All necessary hardware for installation is included
- Lamps operate on 220V single-phase power supply
- Step-down transformer may be ordered separately for 380/420V primary to 220V secondary units
- Alternately, 220V power supply may be used to directly power the UVC ballast(s)
- Magnetic safety interlock terminates power when access panels are removed

Indoor Air Quality (CO₂) Sensors

- Monitors CO₂ levels, reports to the Unit Controller which adjusts economizer dampers as needed

OPTIONS / ACCESSORIES

ECONOMIZER OPTIONS

Factory or Field Installed

9 Economizer (Standard and High Performance Common Features)

- Downflow or Horizontal with Outdoor Air Hood and Barometric Relief Dampers with Exhaust Hood

10 • Barometric Relief Dampers allow relief of excess air

- Aluminum blade dampers prevent blow back and outdoor air infiltration during off cycle, bird screen furnished

NOTE - Optional Horizontal Low Profile Barometric Relief Dampers with Exhaust Hood are available for field installation in a reduced space.

- Occupied/Unoccupied mode with field furnished setback thermostat
- Demand Control Ventilation (DCV) ready using optional CO₂ sensors
- Mixed Air Sensor is furnished for field installation in the rooftop unit
- Sensor is factory installed when Economizers are factory installed
- Single sensible sensor is furnished with Economizer and enables economizer operation if the outdoor temperature is less than the setpoint of the control

Standard Economizer Features

- Gear-driven action
- Return air and outdoor air dampers
- Plug-in connections to unit
- Nylon bearings
- Neoprene seals
- 24-volt
- Fully-modulating spring return motor

Standard Economizer Control Module

- The Standard Economizer Control Module can be adjusted to operate based on outdoor air temperatures

Economizer Controls:

- Damper Minimum Position - Can be set lower than traditional minimum air requirements resulting in cost savings
 - IAQ Sensor - Signals dampers to modulate and maintain 13°C when CO₂ is higher than the CO₂ setpoint
 - Demand Control Ventilation (DCV) LED - A steady green Demand Control Ventilation LED indicates the IAQ reading is higher than setpoint and requires more fresh air
 - Free Cool LED - A steady green LED indicates outdoor air is suitable for free cooling
- Free Cooling runs when outdoor air temperature is lower than the set temperature on the economizer control

NOTE: The Free Cooling default setting for outdoor air temperature sensor is 13°C.

High Performance Economizer Features

Landmark® Packaged Electric / Electric 26 to 44 kW - 50 hz / Page 8

- Gear-driven action
- High torque 24-volt fully-modulating spring return damper motor
- Return air and outdoor air dampers
- Plug-in connections to unit
- Stainless steel bearings
- Enhanced neoprene blade edge seals
- Flexible stainless steel jamb seals minimize air leakage

High Performance Economizer Control Module

- Module provides inputs and outputs to control economizer based on parameter settings
- Module automatically detects sensors by polling to determine which sensors are installed in system
- Module displays any alarm messages (fault detection and diagnostics) as an aid in troubleshooting
- Non-volatile memory retains parameter settings in case of power failure
- Keypad with four navigation buttons and LCD screen is furnished for setting economizer parameters
- Menu Up/Exit (⬆) button returns to the main menu
- Arrow Up (▲) button moves to the previous or next parameter within the selected menu
- Arrow Down (▼) button moves to the next parameter within the selected menu
- Select (enter) (↵) button confirms parameter selection



Main Menu Structure:

- STATUS (economizer and system operation status)
- SETPOINTS (settings for various setpoint parameters)
- SYSTEM SETUP (settings/information about the system)
- ADVANCED SETUP (freeze protection, CO₂ settings, stage 3 delay and additional calibration settings)
- CHECKOUT (damper positions)
- ALARMS (output signal that can be configured for remote alarm monitoring)

NOTE - Refer to Installation Instructions for complete setup information and menu parameters available.

Factory or Field Installed

Single Enthalpy Temperature Control

- Outdoor air enthalpy sensor enables Economizer if the outdoor enthalpy is less than the setpoint of the control

Field Installed

Differential Enthalpy Control

- Order two Single Enthalpy Controls
- One is field installed in the return air section, the other in the outdoor air section
- Allows the economizer control board to select between outdoor air or return air, whichever has lower enthalpy

OPTIONS / ACCESSORIES

EXHAUST OPTIONS

Field Installed

Horizontal Low Profile Barometric Relief Dampers

- Replaces barometric relief dampers furnished with Economizer
- For use when unit is configured for horizontal applications in a reduced space requiring an economizer
- Allows relief of excess air
- Aluminum blade dampers prevent blow back and outdoor air infiltration during off cycle
- Field installed in return air duct
- Exhaust hood with bird screen furnished

NOTE - Requires Horizontal Discharge Kit

Power Exhaust Fan

- Installs internal to unit for downflow applications only with economizer option
- Provides exhaust air pressure relief
- Interlocked to run when supply air blower is operating,
- Fan runs when outdoor air dampers are 50% open (adjustable)
- Motor is overload protected
- Fan - 508 mm diameter
- Five blades
- One 0.25 kW motor

NOTE - Requires Economizer and Downflow Barometric Relief Dampers.

OUTDOOR AIR OPTIONS

Factory or Field Installed

Outdoor Air Damper

- Downflow or Horizontal
- Linked mechanical dampers
- 0 to 25% (fixed) outdoor air adjustable
- Installs in unit
- Includes outdoor air hood
- Automatic model features fully modulating spring return damper motor with plug-in connection
- Manual model features parallel blade, gear-driven dampers with adjustable fixed position

NOTE - Maximum mixed air temperature in cooling mode: 38°C.

ROOF CURBS

Field Installed

- Nailer strip furnished (downflow only)
- Mates to unit
- US National Roofing Contractors Approved
- Shipped knocked down

Hybrid Roof Curbs, Downflow

- Interlocking tabs fasten corners together
- No tools required
- Can also be fastened together with furnished hardware
- Available in 203, 356, 457, and 610 mm heights

Adjustable Pitch Curb

- Fully adjustable pitch curbs provide a level platform for rooftop units allowing flexible installations on roofs with uneven or sloped angles
- Maximum slope is 19 mm per 300 mm in any direction
- Uses interlocking tabs to fasten corners together
- No tools required
- Hardware is furnished to connect upper curb with lower curb
- Available in 356 mm height

Adaptor Curbs (not shown)

- Curbs are regionally sourced
- Dimensions vary based upon the source

NOTE - Contact your local sales representative for a detailed cut sheet with applicable dimensions.

CEILING DIFFUSERS

Field Installed

Ceiling Diffusers (Flush or Step-Down)

- White powder coat finish on diffuser face and grilles
- Insulated UL listed duct liner
- Diffuser box has collars for duct connection
- Step-down diffusers have double deflection blades
- Flush diffusers have fixed blades
- Provisions for suspending
- Internally sealed to prevent recirculation
- Removable return air grille
- Adapts to T-bar ceiling grids or plaster ceilings

Transitions (Supply and Return)

- Used with diffusers
- Installs in roof curb
- Galvanized steel construction
- Flanges furnished for duct connection to diffusers
- Fully insulated

OPTIONAL CONVENTIONAL TEMPERATURE CONTROL SYSTEMS

Comfortsense® 7500 Commercial 7-Day Programmable Thermostat



- Four-Stage Heating / Two-Stage Cooling
- Universal Multi-Stage
- Intuitive Touchscreen Interface
- Automatic Changeover between Heating and Cooling
- Full Seven-Day Programming
- Four Time Periods Per Day
- Temperature and Humidity Control
- One-Touch Away Mode
- Holiday Scheduling
- Smooth Setback Recovery (SSR)
- Performance Reports
- Notifications/Reminders
- Dehumidification/Humiditrol® Control for Split Systems and Rooftop Units
- Economizer Relay Control
- Backlit Display
- Wallplate Furnished
- FDD, ASHRAE and IECC Compliant

Comfortsense® 3000 Commercial 5-2 Day Programmable Thermostat

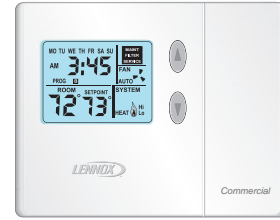

- Two-Stage Heating / Two-Stage Cooling
- Conventional Systems
- Intuitive Interface
- 5-2 Day Programming
- Program Hold
- Remote Indoor Temperature Sensing
- Smooth Setback Recovery (SSR)
- Economizer Relay Control
- Maintenance/Filter/Service Reminders
- Backlit Display
- Wallplate Furnished
- Simple Up and Down Temperature Control

Bacnet Compatible Thermostat With Reheat Function



- 7-Day Programmable
- For units with or without Humiditrol®
- BTL listed MS/TP ensures compatibility with any BACnet system
- Built-in control programs for conventional and heat pump applications
- Conventional systems up to 3-stage heat and 3-stage cool
- Heat pumps with 1 or 2 compressors and up to 2-stage auxiliary heat
- On-board temperature and humidity sensor
- Multiple configurable inputs and outputs enable advanced control strategies
- Set-up Wizard enables rapid system configuration
- No special tools required for installation or commissioning
- Seven-day (2, 4 or 6 event) occupancy scheduling per day
- Backlit 5-inch LCD touchscreen

Description	Model No.	Catalog No.
Comfortsense® 7500 7-Day Programmable	C0STAT06FF2L	17G74
Universal thermostat locking guard (clear)	C0MISC15AE1-	39P21
Temperature Sensors	¹ Remote non-adjustable wall-mount 20k	47W36
	¹ Remote non-adjustable wall-mount 10k	47W37
	Remote non-adjustable discharge air (duct mount)	19L22
	Outdoor temperature sensor	X2658
¹ Remote wall-mount sensors can be applied in any of the following combinations: One Sensor - (1) 47W36 Two Sensors - (2) 47W37 Three Sensors - (2) 47W36 and (1) 47W37 Four Sensors - (4) 47W36 Five Sensors - (3) 47W36 and (2) 47W37		
Comfortsense® 3000 5-2 Day Programmable	C0STAT05FF1L	11Y05
Thermostat wall mounting plate	C0MISC17AE1-	X2659
Temperature Sensor	Remote non-adjustable wall mount 10k averaging	47W37
¹ 7-Day Programmable - Bacnet Compatible	- - -	Y8241
¹ BACnet Thermostat (Y8241) will control units with and without the Humiditrol® option. If there is a mix of units equipped with and without Humiditrol on the same site, this thermostat can be used for all units if desired.		
BACnet Controls (no reheat)	BACnet® Module (factory or field installed)	K0CTRL31B-2 16X71
	BACnet® Room Sensor with Display (field)	K0SNSR01FF1 97W23
	BACnet® Room Sensor without Display (field)	K0SNSR00FF1 97W24
Optional Accessories	Plenum Cable (RJ45/CAT5 75 ft.)	K0MISC00FF1 97W25

OPTIONS / ACCESSORIES

Item Description	Model Number	Catalog Number	Unit Model No.				
			092	102	120	150	
COOLING SYSTEM							
Condensate Drain Trap	Polyvinyl Chloride (PVC) - C1TRAP20AD2	76W26	X	X	X	X	
	Copper - C1TRAP10AD2	76W27	X	X	X	X	
Conventional Fin/Tube Condenser Coil (Replaces Environ™ Coil System)		Factory	O	O	O		
Corrosion Protection		Factory	O	O	O	O	
Drain Pan Overflow Switch	K1SNSR71AB1-	74W42	X	X	X	X	
Efficiency		Standard	O	O	O	O	
Low Ambient Kits	30°F - K1SNSR33B-1	54W16	X	X	X	X	
	0°F - K1LOAM62B-1	18B87	X	X	X		
	0°F - K1LOAM62BS1	18B94				X	
Refrigerant Type		R-410A	O	O	O	O	
BLOWER - SUPPLY AIR							
Blower Option	CAV (Constant Air Volume)	Factory	O	O	O	O	
	MSAVMSAV® (Multi-Stage Air Volume)	Factory	O	O	O	O	
Blower Motors	Belt Drive - 1.5 kW (2 hp)	Factory	O	O	O	O	
	Belt Drive - 2.2 kW (3 hp)	Factory	O	O	O	O	
	Belt Drive - 3.7 kW (5 hp)	Factory	O	O	O	O	
Drive Kits	CAV (rev/min)	MSAV (rev/min)					
See Blower Data Tables for selection	Kit #1 490-740	Kit #1 590-890	Factory	O	O	O	O
	Kit #2 665-920	Kit #2 800-1105	Factory	O	O	O	O
	Kit #3 660-995	Kit #3 795-1195	Factory	O	O	O	O
	Kit #7 610-810	Kit #7 730-970	Factory	O	O	O	O
	Kit #8 780-1000	Kit #8 940-1200	Factory	O	O	O	O
	Kit #9 845-1085	Kit #9 1015-1300	Factory	O	O	O	O
	Kit #10 750-945	Kit #10 900-1135	Factory	O	O	O	O
	Kit #11 865-1095	Kit #11 1040-1315	Factory	O	O	O	O
	Kit #12 940-1190	Kit #12 1125-1425	Factory	O	O	O	O
	CABINET						
Combination Coil/Hail Guards	C1GARD52B-1	13T05	X	X	X	X	
Hinged Access Panels		Factory	O	O	O	O	
Horizontal Discharge Kit	K1HECK00B-1	51W25	X	X	X	X	
Return Air Adaptor Plate (for LC/LG/LH and TC/TG/TH replacement)	C1CONV10B-1	54W96	X	X	X	X	
CONTROLS							
NOTE - Also see Conventional Thermostat Control Systems page 29 for Additional Options.							
Smoke Detector - Supply or Return (Power board and one sensor)	C1SNSR44B-2	11K76	X	X	X	X	
Smoke Detector - Supply and Return (Power board and two sensors)	C1SNSR43B-2	11K80	X	X	X	X	

NOTE - Catalog and model numbers shown are for ordering field installed accessories.

OX - Configure To Order (Factory Installed) or Field Installed

O = Configure To Order (Factory Installed)

X = Field Installed

OPTIONS / ACCESSORIES

Item Description	Model Number	Catalog Number	Unit Model No.			
			092	102	120	150
INDOOR AIR QUALITY						
Air Filters						
Healthy Climate® High Efficiency Air Filters	MERV 8 - C1FLTR15B-1	50W61	X	X	X	X
208 x 635 x 51 mm (Order 4 per unit)	MERV 13 - C1FLTR40B-1	52W41	X	X	X	X
Replacement Media Filter With Metal Mesh Frame (includes non-pleated filter media)	C1FLTR30B-1-	Y3063	X	X	X	X
Indoor Air Quality (CO₂) Sensors						
Sensor - Wall-mount, off-white plastic cover with LCD display	C0SNSR50AE1L	77N39	X	X	X	X
Sensor - Wall-mount, off-white plastic cover, no display	C0SNSR52AE1L	87N53	X	X	X	X
Sensor - Black plastic case with LCD display, rated for plenum mounting	C0SNSR51AE1L	87N52	X	X	X	X
Sensor - Wall-mount, black plastic case, no display, rated for plenum mounting	C0MISC19AE1	87N54	X	X	X	X
CO ₂ Sensor Duct Mounting Kit - for downflow applications	C0MISC19AE1-	85L43	X	X	X	X
Aspiration Box - for duct mounting non-plenum rated CO ₂ sensors (87N53 or 77N39)	C0MISC16AE1-	90N43	X	X	X	X
UVC Germicidal Lamps						
¹ Healthy Climate® UVC Light Kit (220V-1ph)	C1UVCL10B-1	54W62	X	X	X	X
ELECTRICAL						
Voltage 50 hz with neutral	380/420V - 3 phase	Factory	O	O	O	O
^{2, 3} ELECTRIC HEAT						
5.7 kW	380/420V-3ph - C1EH0057B-1M	68W04	OX	OX		
11.5 kW	380/420V-3ph - C1EH0115B-1M	68W05	OX	OX	OX	OX
17.2 kW	380/420V-3ph - C1EH0172B-1M	68W06	OX	OX	OX	OX
23 kW	380/420V-3ph - C1EH0230B-1M	68W07	OX	OX	OX	OX
34.5 kW	380/420V-3ph - C1EH0345B-1M	68W08	OX	OX	OX	OX
45.9 kW	380/420V-3ph - C1EH0459B-1M	68W09			OX	OX
¹ Lamps operate on 220V single-phase power supply. Step-down transformer may be ordered separately for 380/420V primary to 220V secondary units. Alternately, 220V power supply may be used to directly power the UVC ballast(s). ² Nominal kW at 420V-3ph-50hz. ³ NOTE - Factory installed electric heat is only available with high efficiency models.						
NOTE - Catalog and model numbers shown are for ordering field installed accessories. OX - Configure To Order (Factory Installed) or Field Installed O = Configure To Order (Factory Installed) X = Field Installed						

OPTIONS / ACCESSORIES

Item Description	Model Number	Catalog Number	Unit Model No.			
			092	102	120	150
ECONOMIZER						
Standard Economizer						
Standard Economizer with Single Temperature Control Downflow or Horizontal Applications - Includes Barometric Relief Dampers and Air Hoods	K1ECON20B-2	13U45	OX	OX	OX	OX
Standard Economizer Controls						
Single Enthalpy Control	C1SNSR64FF1	53W64	OX	OX	OX	OX
Differential Enthalpy Control (order 2)	C1SNSR64FF1	53W64	X	X	X	X
High Performance Economizer						
High Performance Economizer with Single Temperature Control Downflow or Horizontal Applications - Includes Barometric Relief Dampers and Air Hoods	K1ECON22B-3	17U09	OX	OX	OX	OX
High Performance Economizer Controls						
Single Enthalpy Control	C1SNSR60FF1	10Z75	OX	OX	OX	OX
Differential Enthalpy Control (order 2)	C1SNSR60FF1	10Z75	X	X	X	X
Horizontal Low Profile Barometric Relief Dampers With Exhaust Hood						
Horizontal Low Profile Barometric Relief Dampers With Exhaust Hood	LAGEDH03/15	53K04	X	X	X	X
OUTDOOR AIR						
Outdoor Air Dampers With Outdoor Air Hood						
Motorized	C1DAMP20B-1	14G28	OX	OX	OX	OX
Manual	C1DAMP10B-1	14G29	OX	OX	OX	OX
POWER EXHAUST						
Standard Static	380/420V-3ph - K1PWRE10B-1G	53W45	X	X	X	X
ROOF CURBS						
Hybrid Roof Curbs, Downflow						
203 mm height	C1CURB70B-1	11F54	X	X	X	X
356 mm height	C1CURB71B-1	11F55	X	X	X	X
457 mm height	C1CURB72B-1	11F56	X	X	X	X
610 mm height	C1CURB73B-1	11F57	X	X	X	X
Adjustable Pitch Curb						
356 mm height	C1CURB55B-1	54W50	X	X	X	X
CEILING DIFFUSERS						
Step-Down - Order one	RTD11-95S	13K61	X			
	RTD11-135S	13K62		X	X	
	RTD11-185S	13K63				X
Flush - Order one	FD11-95S	13K56	X			
	FD11-135S	13K57		X	X	
	FD11-185S	13K58				X
Transitions (Supply and Return) - Order one	C1DIFF30B-1	12X65	X			
	C1DIFF31B-1	12X66		X	X	
	C1DIFF32B-1	12X67				X

NOTE - Catalog and model numbers shown are for ordering field installed accessories.
OX - Configure To Order (Factory Installed) or Field Installed
O = Configure To Order (Factory Installed)
X = Field Installed

SPECIFICATIONS

General Data		Nominal kW (Tons)	26 (7.5)	26 (7.5)	26 (7.5)	
		Model Number	KCB092S4B	KCB092S4M	KCA092H4B	
		Efficiency Type	Standard	Standard	High	
		Blower Type	CAV (Constant Air Volume)	MSAV® (Multi-Stage Air Volume)	CAV (Constant Air Volume)	
Cooling Performance	Gross Cooling Capacity - kW (Btuh)		22.5 (76 700)	22.5 (76 700)	23.6 (80 500)	
	¹ Net Cooling Capacity - kW (Btuh)		21.8 (74 500)	21.8 (74 500)	22.7 (77 500)	
	AHRI Rated Air Flow - L/s (cfm)		1133 (2400)	1133 (2400)	1416 (3000)	
	Total Unit Power - kW		6.5	6.5	6.3	
	¹ EER (Btuh/Watt) at 35°C (95°F)		11.5	11.5	12.9	
	² EER (Btuh/Watt) at 46°C (115°F)		8.7	8.7	8.8	
	¹ IEER (Btuh/Watt)		12.9	13.6	12.9	
Refrigerant Type			R-410A	R-410A	R-410A	
Refrigerant Charge	Environ™ Coil System	Circuit 1	1.9 kg (4 lbs. 0 oz.)	1.9 kg (4 lbs. 0 oz.)	2.90 kg (6 lbs. 6 oz.)	
		Circuit 2	1.5 kg (3 lbs. 6 oz.)	1.5 kg (3 lbs. 6 oz.)	2.93 kg (6 lbs. 7 oz.)	
	Conventional Fin/Tube Coil	Circuit 1	4.1 kg (9 lbs. 0 oz.)	4.1 kg (9 lbs. 0 oz.)	- - -	
		Circuit 2	3.1 kg (6 lbs. 13 oz.)	3.1 kg (6 lbs. 13 oz.)	- - -	
Electric Heat Available - See page 12			5.7, 11.5, 17.2, 23, 34.5 KW			
Compressor Type (number)			Scroll (2)	Scroll (2)	Scroll (2)	
Outdoor Coils	Net face area (total) - m ² (sq. ft.)		1.9 (20.5)	1.9 (20.5)	2.6 (28.0)	
	Number of rows		1 (2)	1 (2)	1	
Environ (Fin/Tube)	Fins per m (inch)		906 (23) / 787 (20)	906 (23) / 787 (20)	787 (20)	
Outdoor Coil Fans	Motor - (No.) W (HP)		(2) 249 (1/3)	(2) 249 (1/3)	(2) 249 (1/3)	
	Motor rev/min		896	896	896	
	Total Motor watts		565	565	611	
	Diameter - (No.) mm (in.)		(2) 610 (24)	(2) 610 (24)	(2) 610 (24)	
	Number of blades		3	3	3	
	Total Air volume - L/s (cfm)		3460 (7335)	3460 (7335)	3460 (7335)	
	Indoor Coils	Net face area (total) - m ² (sq. ft.)		1.19 (12.8)	1.19 (12.8)	1.19 (12.8)
Tube diameter - mm (in.)			9.5 (3/8)	9.5 (3/8)	9.5 (3/8)	
Number of rows			2	2	4	
Fins per m (inch)			551 (14)	551 (14)	551 (14)	
Drain connection - Number and size			(1) 1 in. NPT coupling			
	Expansion device type		Refrigerant Metering Orifice (RFC)	Refrigerant Metering Orifice (RFC)	Balance port TXV, removable head	
³ Indoor Blower and Drive Selection	Nominal motor kW (HP)		1.5 (2)	1.5 (2)	1.5 (2)	
	Maximum usable motor kW (HP)		1.7 (2.3)	1.7 (2.3)	1.7 (2.3)	
	Kit # and rev/min range	#1 (490-740)		#1 (590-890)	#1 (590-890)	#1 (490-740)
		#2 (665-920)		#2 (800-1105)	#2 (800-1105)	#2 (665-920)
		#3 (660-995)		#3 (795-1195)	#3 (795-1195)	#3 (660-995)
	Nominal motor kW (HP)		2.2 (3)	2.2 (3)	2.2 (3)	
	Maximum usable motor kW (HP)		2.6 (3.45)	2.6 (3.45)	2.6 (3.45)	
	Kit # and rev/min range	#7 (610-810)		#7 (730-970)	#7 (730-970)	#7 (610-810)
		#8 (780-1000)		#8 (940-1200)	#8 (940-1200)	#8 (780-1000)
		#9 (845-1085)		#9 (1015-1300)	#9 (1015-1300)	#9 (845-1085)
	Nominal motor kW (HP)		3.7 (5)	3.7 (5)	3.7 (5)	
	Maximum usable motor kW (HP)		4.3 (5.75)	4.3 (5.75)	4.3 (5.75)	
Kit # and rev/min range	#10 (750-945)		#10 (900-1135)	#10 (900-1135)	#10 (750-945)	
	#11 (865-1095)		#11 (1040-1315)	#11 (1040-1315)	#11 (865-1095)	
	#12 (940-1190)		#12 (1125-1425)	#12 (1125-1425)	#12 (940-1190)	
Blower wheel nominal diameter x width - mm (in.)		(1) 381 x 381 (15 X 15)	(1) 381 x 381 (15 X 15)	(1) 381 x 381 (15 X 15)		
Filters	Type of filter		Disposable			
	Number and size - mm (in.)		(4) 508 x 508 x 51 (20 x 25 x 2)			
Electrical characteristics			380/420V - 50 hertz - 3 phase with neutral			

NOTE - Net capacity includes evaporator blower motor heat deduction. Gross capacity does not include evaporator blower motor heat deduction.

¹ Tested at conditions included in AHRI Standard 340/360; 35°C (95°F) outdoor air temperature and 27°C (80°F) dry bulb /19°C (67°F) wet bulb entering evaporator air; minimum external duct static pressure while operating at rated voltage and air volumes.

² Rated at 46°C (115°F) outdoor air temperature and 27°C (80°F) db/19°C (67°F) wb entering evaporator air (T3 Conditions).

³ Using total air volume and system static pressure requirements determine from blower performance tables rev/min and motor output required. Maximum usable output of motors furnished are shown. If motors of comparable output are used, be sure to keep within the service factor limitations outlined on the motor nameplate.

NOTE - Units equipped with MSAV® (Multi-Stage Air Volume) option are limited to a motor service factor of 1.0.

SPECIFICATIONS

General Data		Nominal kW (Tons)	30 (8.5)	30 (8.5)	30 (8.5)
		Model Number	KCB102S4B	KCB102S4M	KCA102H4B
		Efficiency Type	Standard	Standard	High
		Blower Type	CAV (Constant Air Volume)	MSAV® (Multi-Stage Air Volume)	CAV (Constant Air Volume)
Cooling Performance	Gross Cooling Capacity - kW (Btuh)		25.5 (86 900)	25.5 (86 900)	26.8 (91 500)
	¹ Net Cooling Capacity - kW (Btuh)		24.7 (84 300)	24.7 (84 300)	25.6 (87 500)
	AHRI Rated Air Flow - L/s (cfm)		1320 (2800)	1320 (2800)	1605 (3400)
	Total Unit Power - kW		7.5	7.5	7.2
	¹ EER (Btuh/Watt) at 35°C (95°F)		11.4	11.4	12.6
	² EER (Btuh/Watt) at 46°C (115°F)		7.5	7.5	8.5
	¹ IEER (Btuh/Watt)		12.9	13.8	12.9
Refrigerant Type			R-410A	R-410A	R-410A
Refrigerant Charge	Environ™ Coil System	Circuit 1	2.0 kg (4 lbs. 5 oz.)	2.0 kg (4 lbs. 5 oz.)	2.96 kg (6 lbs. 8 oz.)
		Circuit 2	1.9 kg (4 lbs. 3 oz.)	1.9 kg (4 lbs. 3 oz.)	3.07 kg (6 lbs. 12 oz.)
	Conventional Fin/Tube Coil	Circuit 1	4.2 kg (9 lbs. 3 oz.)	4.2 kg (9 lbs. 3 oz.)	- - -
		Circuit 2	3.6 kg (7 lbs. 14 oz.)	3.6 kg (7 lbs. 14 oz.)	- - -
Electric Heat Available - See page 12			5.7, 11.5, 17.2, 23, 34.5 KW		
Compressor Type (number)			Scroll (2)	Scroll (2)	Scroll (2)
Outdoor Coils (Fin/Tube)	Net face area (total) - m ² (sq. ft.)		1.9 (20.5)	1.9 (20.5)	2.6 (28.0)
	Number of rows		1 (2)	1 (2)	1
	Fins per m (inch)		906 (23) / 787 (20)	906 (23) / 787 (20)	787 (20)
Outdoor Coil Fans	Motor - (No.) W (HP)		(2) 249 (1/3)	(2) 249 (1/3)	(2) 249 (1/3)
	Motor rev/min		896	896	896
	Total Motor watts		564	564	611
	Diameter - (No.) mm (in.)		(2) 610 (24)	(2) 610 (24)	(2) 610 (24)
	Number of blades		3	3	3
	Total Air volume - L/s (cfm)		3460 (7335)	3460 (7335)	3460 (7335)
Indoor Coils	Net face area (total) - m ² (sq. ft.)		1.19 (12.8)	1.19 (12.8)	1.19 (12.8)
	Tube diameter - mm (in.)		9.5 (3/8)	9.5 (3/8)	9.5 (3/8)
	Number of rows		3	3	4
	Fins per m (inch)		551 (14)	551 (14)	551 (14)
	Drain connection - Number and size		(1) 1 in. NPT coupling		
	Expansion device type		Refrigerant Metering Orifice (RFC)	Refrigerant Metering Orifice (RFC)	Balance port TXV, removable head
³ Indoor Blower and Drive Selection	Nominal motor kW (HP)		1.5 (2)	1.5 (2)	1.5 (2)
	Maximum usable motor kW (HP)		1.7 (2.3)	1.7 (2.3)	1.7 (2.3)
	Kit # and rev/min range	#1 (490-740)		#1 (590-890)	#1 (490-740)
		#2 (665-920)		#2 (800-1105)	#2 (665-920)
		#3 (660-995)		#3 (795-1195)	#3 (660-995)
	Nominal motor kW (HP)		2.2 (3)	2.2 (3)	2.2 (3)
	Maximum usable motor kW (HP)		2.6 (3.45)	2.6 (3.45)	2.6 (3.45)
	Kit # and rev/min range	#7 (610-810)		#7 (730-970)	#7 (610-810)
		#8 (780-1000)		#8 (940-1200)	#8 (780-1000)
		#9 (845-1085)		#9 (1015-1300)	#9 (845-1085)
	Nominal motor kW (HP)		3.7 (5)	3.7 (5)	3.7 (5)
	Maximum usable motor kW (HP)		4.3 (5.75)	4.3 (5.75)	4.3 (5.75)
Kit # and rev/min range	#10 (750-945)		#10 (900-1135)	#10 (750-945)	
	#11 (865-1095)		#11 (1040-1315)	#11 (865-1095)	
	#12 (940-1190)		#12 (1125-1425)	#12 (940-1190)	
Blower wheel nominal diameter x width - mm (in.)		(1) 381 x 381 (15 X 15)	(1) 381 x 381 (15 X 15)	(1) 381 x 381 (15 X 15)	
Filters	Type of filter		Disposable		
	Number and size - mm (in.)		(4) 508 x 508 x 51 (20 x 25 x 2)		
Electrical characteristics			380/420V - 50 hertz - 3 phase with neutral		

NOTE - Net capacity includes evaporator blower motor heat deduction. Gross capacity does not include evaporator blower motor heat deduction.

¹ Tested at conditions included in AHRI Standard 340/360; 35°C (95°F) outdoor air temperature and 27°C (80°F) dry bulb /19°C (67°F) wet bulb entering evaporator air; minimum external duct static pressure while operating at rated voltage and air volumes.

² Rated at 46°C (115°F) outdoor air temperature and 27°C (80°F) db/19°C (67°F) wb entering evaporator air (T3 Conditions).

³ Using total air volume and system static pressure requirements determine from blower performance tables rev/min and motor output required. Maximum usable output of motors furnished are shown. If motors of comparable output are used, be sure to keep within the service factor limitations outlined on the motor nameplate.

NOTE – Units equipped with MSAV® (Multi-Stage Air Volume) option are limited to a motor service factor of 1.0.

SPECIFICATIONS

General Data		Nominal kW (Tons)	35 (10)	35 (10)	35 (10)	
		Model Number	KCB120S4B	KCB120S4M	KCA120H4B	
		Efficiency Type	Standard	Standard	High	
		Blower Type	CAV (Constant Air Volume)	MSAV® (Multi-Stage Air Volume)	CAV (Constant Air Volume)	
Cooling Performance	Gross Cooling Capacity - kW (Btuh)		30.3 (103 500)	30.3 (103 500)	32.1 (109 700)	
	¹ Net Cooling Capacity - kW (Btuh)		29.3 (100 000)	29.3 (100 000)	30.9 (105 600)	
	AHRI Rated Air Flow - L/s (cfm)		1416 (3000)	1416 (3000)	1700 (3600)	
	Total Unit Power - kW		8.9	8.9	8.7	
	¹ EER (Btuh/Watt) at 35°C (95°F)		11.3	11.3	12.4	
	² EER (Btuh/Watt) at 46°C (115°F)		8.2	8.2	8.6	
	¹ IEER (Btuh/Watt)		12.9	13.6	12.7	
Refrigerant Type			R-410A	R-410A	R-410A	
Refrigerant Charge	Environ™ Coil System	Circuit 1	2.5 kg (5 lbs. 7 oz.)	2.5 kg (5 lbs. 7 oz.)	3.3 kg (7 lbs. 4 oz.)	
		Circuit 2	2.6 kg (5 lbs. 12 oz.)	2.6 kg (5 lbs. 12 oz.)	3.4 kg (7 lbs. 8 oz.)	
	Conventional Fin/Tube Coil	Circuit 1	4.5 kg (9 lbs. 15 oz.)	4.5 kg (9 lbs. 15 oz.)	---	
		Circuit 2	4.1 kg (9 lbs. 1 oz.)	4.1 kg (9 lbs. 1 oz.)	---	
Electric Heat Available - See page 12			11.5, 17.2, 23, 34.5, 45.9 KW			
Compressor Type (number)			Scroll (2)	Scroll (2)	Scroll (2)	
Outdoor Coils	Net face area (total) - m ² (sq. ft.)		2.6 (28.0)	2.6 (28.0)	2.6 (28.0)	
	Number of rows		1 (2)	1 (2)	1	
Environ (Fin/Tube)	Fins per m (inch)		906 (23) / 787 (20)	906 (23) / 787 (20)	787 (20)	
Outdoor Coil Fans	Motor - (No.) W (HP)		(2) 249 (1/3)	(2) 249 (1/3)	(2) 249 (1/3)	
	Motor rev/min		896	896	896	
	Total Motor watts		527	527	611	
	Diameter - (No.) mm (in.)		(2) 610 (24)	(2) 610 (24)	(2) 610 (24)	
	Number of blades		3	3	3	
	Total Air volume - L/s (cfm)		3660 (7750)	3660 (7750)	3460 (7335)	
Indoor Coils	Net face area (total) - m ² (sq. ft.)		1.19 (12.8)	1.19 (12.8)	1.26 (13.5)	
	Tube diameter - mm (in.)		9.5 (3/8)	9.5 (3/8)	9.5 (3/8)	
	Number of rows		4	4	4	
	Fins per m (inch)		551 (14)	551 (14)	551 (14)	
	Drain connection - Number and size		(1) 1 in. NPT coupling			
	Expansion device type		Refrigerant Metering Orifice (RFC)	Refrigerant Metering Orifice (RFC)	Balance port TXV, removable head	
³ Indoor Blower and Drive Selection	Nominal motor kW (HP)		1.5 (2)	1.5 (2)	1.5 (2)	
	Maximum usable motor kW (HP)		1.7 (2.3)	1.7 (2.3)	1.7 (2.3)	
	Kit # and rev/min range	#1 (490-740)		#1 (590-890)	#1 (590-890)	#1 (490-740)
		#2 (665-920)		#2 (800-1105)	#2 (800-1105)	#2 (665-920)
		#3 (660-995)		#3 (795-1195)	#3 (795-1195)	#3 (660-995)
	Nominal motor kW (HP)		2.2 (3)	2.2 (3)	2.2 (3)	
	Maximum usable motor kW (HP)		2.6 (3.45)	2.6 (3.45)	2.6 (3.45)	
	Kit # and rev/min range	#7 (610-810)		#7 (730-970)	#7 (730-970)	#7 (610-810)
		#8 (780-1000)		#8 (940-1200)	#8 (940-1200)	#8 (780-1000)
		#9 (845-1085)		#9 (1015-1300)	#9 (1015-1300)	#9 (845-1085)
	Nominal motor kW (HP)		3.7 (5)	3.7 (5)	3.7 (5)	
	Maximum usable motor kW (HP)		4.3 (5.75)	4.3 (5.75)	4.3 (5.75)	
Kit # and rev/min range	#10 (750-945)		#10 (900-1135)	#10 (900-1135)	#10 (750-945)	
	#11 (865-1095)		#11 (1040-1315)	#11 (1040-1315)	#11 (865-1095)	
	#12 (940-1190)		#12 (1125-1425)	#12 (1125-1425)	#12 (940-1190)	
Blower wheel nominal diameter x width - mm (in.)		(1) 381 x 381 (15 X 15)	(1) 381 x 381 (15 X 15)	(1) 381 x 381 (15 X 15)		
Filters	Type of filter		Disposable			
	Number and size - mm (in.)		(4) 508 x 508 x 51 (20 x 25 x 2)			
Electrical characteristics			380/420V - 50 hertz - 3 phase with neutral			

NOTE - Net capacity includes evaporator blower motor heat deduction. Gross capacity does not include evaporator blower motor heat deduction.

¹ Tested at conditions included in AHRI Standard 340/360; 35°C (95°F) outdoor air temperature and 27°C (80°F) dry bulb /19°C (67°F) wet bulb entering evaporator air; minimum external duct static pressure while operating at rated voltage and air volumes

² Rated at 46°C (115°F) outdoor air temperature and 27°C (80°F) db/19°C (67°F) wb entering evaporator air (T3 Conditions)..

³ Using total air volume and system static pressure requirements determine from blower performance tables rev/min and motor output required. Maximum usable output of motors furnished are shown. If motors of comparable output are used, be sure to keep within the service factor limitations outlined on the motor nameplate.

NOTE - Units equipped with MSAV® (Multi-Stage Air Volume) option are limited to a motor service factor of 1.0.

SPECIFICATIONS

General Data		Nominal kW (Tons)	44 (12.5)	44 (12.5)	
		Model Number	KCB150S4B	KCB150S4M	
		Efficiency Type	Standard	Standard	
		Blower Type	CAV (Constant Air Volume)	MSAV® (Multi-Stage Air Volume)	
Cooling Performance	Gross Cooling Capacity - kW (Btuh)		38.7 (130 000)	38.7 (130 000)	
	¹ Net Cooling Capacity - kW (Btuh)		36.1 (123 300)	36.1 (123 300)	
	AHRI Rated Air Flow - L/s (cfm)		1864 (3950)	1864 (3950)	
	Total Unit Power - kW		11.0	11.0	
	¹ EER (Btuh/Watt) at 35°C (95°F)		11.2	11.2	
	² EER (Btuh/Watt) at 46°C (115°F)		7.7	7.7	
	¹ IEER (Btuh/Watt)		12.4	13.5	
Refrigerant Charge	Conventional Fin/Tube Circuit 1 Coil Circuit 2		6.35 kg (14 lbs. 0 oz.) 6.12 kg (13 lbs. 8 oz.)	6.35 kg (14 lbs. 0 oz.) 6.12 kg (13 lbs. 8 oz.)	
Electric Heat Available - See page 12			11.5, 17.2, 23, 34.5, 45.9 KW		
Compressor Type (number)			Scroll (2)	Scroll (2)	
Outdoor Coils (Fin/Tube)	Net face area (total) - m ² (sq. ft.)		2.6 (28.0)	2.6 (28.0)	
	Number of rows		3	3	
	Fins per m (inch)		787 (20)	787 (20)	
Outdoor Coil Fans	Motor - (No.) W (HP)		(2) 373 (1/2)	(2) 373 (1/2)	
	Motor rev/min		896	896	
	Total Motor watts		802	802	
	Diameter - (No.) mm (in.)		(2) 610 (24)	(2) 610 (24)	
	Number of blades		3	3	
	Total Air volume - L/s (cfm)		3815 (8085)	3815 (8085)	
Indoor Coils	Net face area (total) - m ² (sq. ft.)		1.26 (13.5)	1.26 (13.5)	
	Tube diameter - mm (in.)		9.5 (3/8)	9.5 (3/8)	
	Number of rows		4	4	
	Fins per m (inch)		551 (14)	551 (14)	
	Drain connection - Number and size		(1) 1 in. NPT coupling		
	Expansion device type		Balance port TXV, removable head		
³ Indoor Blower and Drive Selection	Nominal motor kW (HP)		1.5 (2)	1.5 (2)	
	Maximum usable motor kW (HP)		1.7 (2.3)	1.7 (2.3)	
	Kit # and rev/min range			#1 (490-740)	#1 (590-890)
				#2 (665-920)	#2 (800-1105)
				#3 (660-995)	#3 (795-1195)
	Nominal motor kW (HP)		2.2 (3)	2.2 (3)	
	Maximum usable motor kW (HP)		2.6 (3.45)	2.6 (3.45)	
	Kit # and rev/min range			#7 (610-810)	#7 (730-970)
				#8 (780-1000)	#8 (940-1200)
				#9 (845-1085)	#9 (1015-1300)
	Nominal motor kW (HP)		3.7 (5)	3.7 (5)	
	Maximum usable motor kW (HP)		4.3 (5.75)	4.3 (5.75)	
	Kit # and rev/min range			#10 (750-945)	#10 (900-1135)
			#11 (865-1095)	#11 (1040-1315)	
			#12 (940-1190)	#12 (1125-1425)	
	Blower wheel nominal diameter x width - mm (in.)		(1) 381 x 381 (15 X 15)	(1) 381 x 381 (15 X 15)	
Filters	Type of filter		Disposable		
	Number and size - mm (in.)		(4) 508 x 508 x 51 (20 x 25 x 2)		
Electrical characteristics			380/420V - 50 hertz - 3 phase with neutral		

NOTE - Net capacity includes evaporator blower motor heat deduction. Gross capacity does not include evaporator blower motor heat deduction.

¹ Tested at conditions included in AHRI Standard 340/360; 35°C (95°F) outdoor air temperature and 27°C (80°F) dry bulb /19°C (67°F) wet bulb entering evaporator air; minimum external duct static pressure while operating at rated voltage and air volumes

² Rated at 46°C (115°F) outdoor air temperature and 27°C (80°F) db/19°C (67°F) wb entering evaporator air (T3 Conditions)..

³ Using total air volume and system static pressure requirements determine from blower performance tables rev/min and motor output required. Maximum usable output of motors furnished are shown. If motors of comparable output are used, be sure to keep within the service factor limitations outlined on the motor nameplate.

NOTE – Units equipped with MSAV® (Multi-Stage Air Volume) option are limited to a motor service factor of 1.0.

RATINGS - STANDARD EFFICIENCY

NOTE – For Temperatures and Capacities not shown in tables, see bulletin – Cooling Unit Rating Table Correction Factor Data in Miscellaneous Engineering Data section.

26 KW STANDARD EFFICIENCY - KCB092S4 (1ST STAGE) - CONSTANT AIR VOLUME

Entering Wet Bulb Temperature	Total Air Volume	Outdoor Air Temperature Entering Outdoor Coil																							
		18.3°C						23.9°C						29.4°C						35°C					
		Total Cool Cap.	Comp. Motor Input	Sensible To Total Ratio (S/T)			Total Cool Cap.	Comp. Motor Input	Sensible To Total Ratio (S/T)			Total Cool Cap.	Comp. Motor Input	Sensible To Total Ratio (S/T)			Total Cool Cap.	Comp. Motor Input	Sensible To Total Ratio (S/T)						
				Dry Bulb					Dry Bulb					Dry Bulb					Dry Bulb						
L/s	kW	kW	24°C	27°C	29°C	kW	kW	24°C	27°C	29°C	kW	kW	24°C	27°C	29°C	kW	kW	24°C	27°C	29°C					
17.2°C	1135	16.6	2.27	0.68	0.81	0.95	15.9	2.53	0.69	0.83	0.97	15.1	2.83	0.70	0.84	0.99	14.2	3.19	0.71	0.87	1.00				
	1415	17.5	2.29	0.72	0.87	1.00	16.7	2.55	0.73	0.89	1.00	15.9	2.85	0.74	0.91	1.00	14.9	3.21	0.76	0.94	1.00				
	1700	18.2	2.30	0.76	0.93	1.00	17.4	2.56	0.77	0.95	1.00	16.5	2.86	0.78	0.98	1.00	15.5	3.22	0.80	1.00	1.00				
19.4°C	1135	17.4	2.28	0.55	0.66	0.78	16.6	2.55	0.55	0.67	0.79	15.8	2.85	0.55	0.68	0.81	14.9	3.20	0.56	0.69	0.83				
	1415	18.4	2.30	0.57	0.70	0.84	17.5	2.56	0.57	0.71	0.86	16.6	2.87	0.58	0.72	0.88	15.6	3.22	0.58	0.73	0.90				
	1700	19.0	2.32	0.59	0.74	0.90	18.1	2.58	0.59	0.75	0.92	17.1	2.88	0.60	0.76	0.94	16.1	3.23	0.61	0.78	0.97				
21.7°C	1135	18.2	2.30	0.42	0.53	0.64	17.4	2.56	0.42	0.54	0.65	16.5	2.86	0.42	0.54	0.66	15.6	3.22	0.42	0.55	0.67				
	1415	19.2	2.32	0.43	0.56	0.68	18.3	2.58	0.43	0.56	0.69	17.3	2.88	0.42	0.57	0.70	16.3	3.23	0.42	0.57	0.72				
	1700	19.9	2.34	0.45	0.58	0.71	19.0	2.59	0.44	0.59	0.73	17.9	2.89	0.45	0.59	0.74	16.8	3.25	0.45	0.60	0.76				

26 KW STANDARD EFFICIENCY - KCB092S4 (2ND STAGE) - CONSTANT AIR VOLUME

Entering Wet Bulb Temperature	Total Air Volume	Outdoor Air Temperature Entering Outdoor Coil																							
		26.7°C						35°C						43.3°C						46°C					
		Total Cool Cap.	Comp. Motor Input	Sensible To Total Ratio (S/T)			Total Cool Cap.	Comp. Motor Input	Sensible To Total Ratio (S/T)			Total Cool Cap.	Comp. Motor Input	Sensible To Total Ratio (S/T)			Total Cool Cap.	Comp. Motor Input	Sensible To Total Ratio (S/T)						
				Dry Bulb					Dry Bulb					Dry Bulb					Dry Bulb						
L/s	kW	kW	24°C	27°C	29°C	kW	kW	24°C	27°C	29°C	kW	kW	24°C	27°C	29°C	kW	kW	24°C	27°C	29°C					
17.2°C	1135	23.0	4.47	0.71	0.86	0.99	20.8	5.36	0.73	0.90	1.00	18.4	6.46	0.76	0.95	1.00	17.7	6.87	.80	.98	1.00				
	1415	24.2	4.50	0.76	0.94	1.00	21.9	5.39	0.79	0.98	1.00	19.5	6.50	0.83	1.00	1.00	18.8	6.91	.88	1.00	1.00				
	1700	25.1	4.51	0.81	0.99	1.00	22.8	5.41	0.85	1.00	1.00	20.5	6.53	0.91	1.00	1.00	19.8	6.94	.95	1.00	1.00				
19.4°C	1135	24.3	4.50	0.56	0.69	0.82	22.0	5.39	0.57	0.71	0.86	19.6	6.50	0.57	0.74	0.91	18.8	6.91	.60	.80	.92				
	1415	25.6	4.52	0.59	0.74	0.90	23.2	5.42	0.60	0.76	0.95	20.5	6.53	0.62	0.81	0.99	19.6	6.94	.65	.87	.99				
	1700	26.5	4.54	0.62	0.79	0.97	24.0	5.44	0.63	0.82	1.00	21.1	6.55	0.65	0.88	1.00	20.2	6.96	.70	.95	1.00				
21.7°C	1135	25.5	4.52	0.42	0.55	0.67	23.2	5.42	0.41	0.56	0.69	20.7	6.54	0.40	0.57	0.71	19.9	6.95	.42	.60	.72				
	1415	26.8	4.54	0.43	0.58	0.72	24.4	5.45	0.43	0.59	0.74	21.7	6.57	0.43	0.61	0.78	20.8	6.98	.44	.65	.79				
	1700	27.8	4.56	0.44	0.61	0.76	25.3	5.47	0.44	0.63	0.80	22.4	6.60	0.45	0.65	0.86	21.5	7.01	.47	.70	.85				

Entering Wet Bulb Temperature	Total Air Volume	Outdoor Air Temperature Entering Outdoor Coil																	
		48°C						50°C						51.7°C					
		Total Cool Cap.	Comp. Motor Input	Sensible To Total Ratio (S/T)			Total Cool Cap.	Comp. Motor Input	Sensible To Total Ratio (S/T)			Total Cool Cap.	Comp. Motor Input	Sensible To Total Ratio (S/T)					
				Dry Bulb					Dry Bulb					Dry Bulb					
L/s	kW	kW	24°C	27°C	29°C	kW	kW	24°C	27°C	29°C	kW	kW	24°C	27°C	29°C				
17.2°C	1135	17.0	7.19	0.78	0.98	1.00	16.4	7.53	0.80	0.99	1.00	15.9	7.84	0.81	1.00	1.00			
	1415	18.1	7.23	0.87	1.00	1.00	17.5	7.58	0.88	1.00	1.00	17.0	7.88	0.90	1.00	1.00			
	1700	19.0	7.27	0.94	1.00	1.00	18.3	7.61	0.96	1.00	1.00	17.8	7.92	0.97	1.00	1.00			
19.4°C	1135	18.1	7.23	0.58	0.76	0.95	17.4	7.58	0.59	0.77	0.97	16.8	7.88	0.59	0.78	0.98			
	1415	18.9	7.26	0.63	0.84	1.00	18.1	7.60	0.64	0.86	1.00	17.5	7.91	0.64	0.88	1.00			
	1700	19.4	7.29	0.67	0.92	1.00	18.7	7.63	0.68	0.94	1.00	18.0	7.94	0.69	0.96	1.00			
21.7°C	1135	19.1	7.27	0.40	0.58	0.74	18.4	7.61	0.40	0.58	0.75	17.8	7.92	0.40	0.59	0.76			
	1415	20.0	7.31	0.43	0.62	0.82	19.3	7.65	0.43	0.63	0.83	18.6	7.96	0.43	0.64	0.85			
	1700	20.6	7.33	0.45	0.67	0.90	19.8	7.68	0.45	0.68	0.92	19.2	7.99	0.46	0.69	0.94			

RATINGS - STANDARD EFFICIENCY

NOTE – For Temperatures and Capacities not shown in tables, see bulletin – Cooling Unit Rating Table Correction Factor Data in Miscellaneous Engineering Data section.

30 KW STANDARD EFFICIENCY - KCB102S4 (1ST STAGE) - CONSTANT AIR VOLUME

Entering Wet Bulb Temperature	Total Air Volume	Outdoor Air Temperature Entering Outdoor Coil																			
		18.3°C					23.9°C					29.4°C					35°C				
		Total Cool Cap.	Comp. Motor Input	Sensible To Total Ratio (S/T)			Total Cool Cap.	Comp. Motor Input	Sensible To Total Ratio (S/T)			Total Cool Cap.	Comp. Motor Input	Sensible To Total Ratio (S/T)			Total Cool Cap.	Comp. Motor Input	Sensible To Total Ratio (S/T)		
				Dry Bulb					Dry Bulb					Dry Bulb					Dry Bulb		
L/s	kW	kW	24°C	27°C	29°C	kW	kW	24°C	27°C	29°C	kW	kW	24°C	27°C	29°C	kW	kW	24°C	27°C	29°C	
17.2°C	1285	14.9	2.05	0.66	0.81	0.98	14.0	2.28	0.66	0.82	1.00	12.9	2.55	0.66	0.85	1.00	11.8	2.86	0.67	0.88	1.00
	1605	15.9	2.05	0.70	0.90	1.00	14.8	2.29	0.71	0.92	1.00	13.7	2.56	0.72	0.95	1.00	12.5	2.87	0.73	0.98	1.00
	1925	16.5	2.06	0.75	0.97	1.00	15.4	2.29	0.77	1.00	1.00	14.3	2.57	0.79	1.00	1.00	13.2	2.88	0.81	1.00	1.00
19.4°C	1285	15.9	2.05	0.52	0.64	0.77	14.9	2.29	0.51	0.64	0.78	13.8	2.56	0.51	0.64	0.80	12.7	2.87	0.50	0.65	0.83
	1605	16.9	2.05	0.55	0.68	0.85	15.8	2.29	0.55	0.69	0.87	14.6	2.56	0.54	0.70	0.91	13.4	2.88	0.54	0.71	0.94
	1925	17.6	2.06	0.57	0.73	0.94	16.4	2.30	0.57	0.74	0.96	15.2	2.57	0.58	0.76	0.99	14.0	2.89	0.58	0.79	1.00
21.7°C	1285	16.8	2.06	0.40	0.51	0.62	15.8	2.29	0.39	0.51	0.62	14.7	2.57	0.37	0.50	0.63	13.5	2.88	0.36	0.50	0.63
	1605	17.8	2.06	0.41	0.54	0.66	16.7	2.30	0.40	0.54	0.67	15.5	2.57	0.39	0.54	0.68	14.3	2.89	0.38	0.54	0.69
	1925	18.6	2.07	0.43	0.57	0.71	17.4	2.31	0.42	0.57	0.72	16.1	2.58	0.41	0.57	0.74	14.8	2.90	0.40	0.58	0.76

30 KW STANDARD EFFICIENCY - KCB102S4 (2ND STAGE) - CONSTANT AIR VOLUME

Entering Wet Bulb Temperature	Total Air Volume	Outdoor Air Temperature Entering Outdoor Coil																			
		26.7°C					35°C					43.3°C					46°C				
		Total Cool Cap.	Comp. Motor Input	Sensible To Total Ratio (S/T)			Total Cool Cap.	Comp. Motor Input	Sensible To Total Ratio (S/T)			Total Cool Cap.	Comp. Motor Input	Sensible To Total Ratio (S/T)			Total Cool Cap.	Comp. Motor Input	Sensible To Total Ratio (S/T)		
				Dry Bulb					Dry Bulb					Dry Bulb					Dry Bulb		
L/s	kW	kW	24°C	27°C	29°C	kW	kW	24°C	27°C	29°C	kW	kW	24°C	27°C	29°C	kW	kW	24°C	27°C	29°C	
17.2°C	1285	25.6	5.07	0.70	0.86	1.00	22.4	6.02	0.71	0.89	1.00	19.0	7.26	0.73	0.95	1.00	17.9	7.72	.76	.99	1.00
	1605	27.1	5.08	0.76	0.94	1.00	23.7	6.04	0.77	0.98	1.00	20.3	7.26	0.81	1.00	1.00	19.5	7.72	.85	1.00	1.00
	1925	28.3	5.09	0.81	1.00	1.00	25.0	6.04	0.84	1.00	1.00	21.7	7.27	0.89	1.00	1.00	20.7	7.73	.93	1.00	1.00
19.4°C	1285	27.3	5.08	0.54	0.68	0.83	24.1	6.03	0.53	0.69	0.85	20.6	7.26	0.52	0.71	0.90	19.4	7.73	.54	.76	.90
	1605	28.9	5.08	0.58	0.74	0.91	25.5	6.05	0.58	0.75	0.95	21.8	7.28	0.57	0.78	0.99	20.5	7.73	.60	.85	.99
	1925	30.1	5.10	0.61	0.79	0.98	26.5	6.06	0.61	0.82	1.00	22.6	7.28	0.62	0.86	1.00	21.3	7.73	.65	.93	1.00
21.7°C	1285	29.0	5.09	0.40	0.54	0.67	25.6	6.05	0.37	0.53	0.67	22.0	7.26	0.34	0.52	0.69	21.0	7.73	.34	.55	.68
	1605	30.6	5.11	0.42	0.57	0.72	27.1	6.07	0.40	0.57	0.74	23.3	7.29	0.37	0.57	0.76	22.2	7.74	.37	.61	.76
	1925	31.8	5.11	0.43	0.61	0.77	28.1	6.08	0.42	0.61	0.80	24.2	7.30	0.39	0.62	0.84	23.0	7.74	.40	.66	.83

Entering Wet Bulb Temperature	Total Air Volume	Outdoor Air Temperature Entering Outdoor Coil														
		48°C					50°C					51.7°C				
		Total Cool Cap.	Comp. Motor Input	Sensible To Total Ratio (S/T)			Total Cool Cap.	Comp. Motor Input	Sensible To Total Ratio (S/T)			Total Cool Cap.	Comp. Motor Input	Sensible To Total Ratio (S/T)		
				Dry Bulb					Dry Bulb					Dry Bulb		
L/s	kW	kW	24°C	27°C	29°C	kW	kW	24°C	27°C	29°C	kW	kW	24°C	27°C	29°C	
17.2°C	1285	17.0	8.09	0.74	0.98	1.00	16.1	8.50	0.75	0.99	1.00	15.3	8.86	0.75	1.00	1.00
	1605	18.4	8.10	0.83	1.00	1.00	17.6	8.51	0.85	1.00	1.00	16.9	8.89	0.87	1.00	1.00
	1925	19.7	8.12	0.93	1.00	1.00	18.8	8.52	0.95	1.00	1.00	18.0	8.88	0.96	1.00	1.00
19.4°C	1285	18.5	8.10	0.52	0.72	0.94	17.6	8.51	0.51	0.73	0.96	16.7	8.88	0.51	0.74	0.97
	1605	19.5	8.10	0.57	0.81	1.00	18.6	8.51	0.57	0.83	1.00	17.7	8.87	0.57	0.84	1.00
	1925	20.3	8.10	0.62	0.90	1.00	19.3	8.52	0.63	0.92	1.00	18.4	8.88	0.63	0.94	1.00
21.7°C	1285	19.9	8.11	0.32	0.52	0.70	19.0	8.52	0.30	0.52	0.71	18.1	8.89	0.30	0.52	0.72
	1605	21.0	8.12	0.35	0.58	0.79	20.0	8.53	0.34	0.58	0.80	19.2	8.89	0.34	0.58	0.82
	1925	21.9	8.13	0.38	0.63	0.88	20.8	8.52	0.38	0.63	0.90	19.9	8.89	0.37	0.64	0.91

RATINGS - STANDARD EFFICIENCY

NOTE – For Temperatures and Capacities not shown in tables, see bulletin – Cooling Unit Rating Table Correction Factor Data in Miscellaneous Engineering Data section.

35 KW STANDARD EFFICIENCY - KCB120S4 (1ST STAGE) - CONSTANT AIR VOLUME

Entering Wet Bulb Temperature	Total Air Volume	Outdoor Air Temperature Entering Outdoor Coil																			
		18.3°C					23.9°C					29.4°C					35°C				
		Total Cool Cap.	Comp. Motor Input	Sensible To Total Ratio (S/T)			Total Cool Cap.	Comp. Motor Input	Sensible To Total Ratio (S/T)			Total Cool Cap.	Comp. Motor Input	Sensible To Total Ratio (S/T)			Total Cool Cap.	Comp. Motor Input	Sensible To Total Ratio (S/T)		
				Dry Bulb					Dry Bulb					Dry Bulb					Dry Bulb		
L/s	kW	kW	24°C	27°C	29°C	kW	kW	24°C	27°C	29°C	kW	kW	24°C	27°C	29°C	kW	kW	24°C	27°C	29°C	
17.2°C	1510	16.1	2.32	0.69	0.85	1.00	15.0	2.63	0.69	0.86	1.00	13.7	2.98	0.70	0.88	1.00	12.4	3.37	0.71	0.91	1.00
	1890	17.1	2.32	0.75	0.93	1.00	15.9	2.64	0.75	0.96	1.00	14.6	3.00	0.76	0.98	1.00	13.3	3.39	0.78	1.00	1.00
	2265	17.9	2.33	0.80	1.00	1.00	16.7	2.65	0.81	1.00	1.00	15.4	3.01	0.83	1.00	1.00	14.2	3.41	0.86	1.00	1.00
19.4°C	1510	17.3	2.32	0.55	0.67	0.81	16.1	2.64	0.54	0.67	0.82	14.8	3.00	0.53	0.68	0.84	13.5	3.40	0.52	0.69	0.87
	1890	18.3	2.34	0.57	0.72	0.90	17.0	2.65	0.57	0.74	0.92	15.6	3.02	0.57	0.74	0.94	14.3	3.41	0.57	0.76	0.98
	2265	19.0	2.34	0.61	0.78	0.97	17.6	2.66	0.61	0.79	0.99	16.3	3.03	0.60	0.81	1.00	14.8	3.43	0.61	0.83	1.00
21.7°C	1510	18.6	2.34	0.41	0.54	0.65	17.3	2.66	0.40	0.53	0.66	15.9	3.02	0.38	0.52	0.66	14.6	3.42	0.36	0.52	0.67
	1890	19.5	2.35	0.42	0.57	0.70	18.1	2.67	0.42	0.57	0.72	16.8	3.04	0.40	0.57	0.73	15.3	3.44	0.39	0.57	0.74
	2265	20.2	2.35	0.45	0.61	0.76	18.8	2.68	0.44	0.61	0.77	17.3	3.05	0.42	0.60	0.79	15.8	3.45	0.40	0.61	0.81

35 KW STANDARD EFFICIENCY - KCB120S4 (2ND STAGE) - CONSTANT AIR VOLUME

Entering Wet Bulb Temperature	Total Air Volume	Outdoor Air Temperature Entering Outdoor Coil																			
		26.7°C					35°C					43.3°C					46°C				
		Total Cool Cap.	Comp. Motor Input	Sensible To Total Ratio (S/T)			Total Cool Cap.	Comp. Motor Input	Sensible To Total Ratio (S/T)			Total Cool Cap.	Comp. Motor Input	Sensible To Total Ratio (S/T)			Total Cool Cap.	Comp. Motor Input	Sensible To Total Ratio (S/T)		
				Dry Bulb					Dry Bulb					Dry Bulb					Dry Bulb		
L/s	kW	kW	24°C	27°C	29°C	kW	kW	24°C	27°C	29°C	kW	kW	24°C	27°C	29°C	kW	kW	24°C	27°C	29°C	
17.2°C	1510	30.4	5.70	0.71	0.88	1.00	26.4	6.86	0.72	0.92	1.00	22.2	8.23	0.74	0.98	1.00	21.0	8.73	.78	1.00	1.00
	1890	32.3	5.72	0.78	0.98	1.00	28.3	6.90	0.80	1.00	1.00	24.2	8.29	0.84	1.00	1.00	23.2	8.79	.88	1.00	1.00
	2265	34.1	5.75	0.84	1.00	1.00	30.1	6.94	0.88	1.00	1.00	25.9	8.34	0.93	1.00	1.00	24.8	8.85	.97	1.00	1.00
19.4°C	1510	32.9	5.73	0.54	0.69	0.84	28.8	6.91	0.53	0.70	0.88	24.3	8.30	0.52	0.72	0.93	22.8	8.78	.54	.78	.93
	1890	34.7	5.76	0.59	0.76	0.94	30.3	6.95	0.58	0.78	0.98	25.6	8.33	0.58	0.81	1.00	24.1	8.83	.60	.88	1.00
	2265	36.0	5.78	0.62	0.82	1.00	31.4	6.97	0.63	0.85	1.00	26.7	8.37	0.63	0.91	1.00	25.1	8.86	.67	.97	1.00
21.7°C	1510	35.3	5.76	0.40	0.54	0.67	31.1	6.96	0.37	0.53	0.68	26.5	8.36	0.33	0.52	0.70	25.1	8.85	.33	.55	.69
	1890	37.2	5.80	0.42	0.58	0.74	32.7	7.00	0.40	0.58	0.76	27.9	8.40	0.37	0.58	0.79	26.4	8.90	.36	.62	.78
	2265	38.5	5.82	0.44	0.62	0.80	33.8	7.03	0.42	0.62	0.83	28.9	8.44	0.40	0.64	0.88	27.4	8.94	.40	.68	.87

Entering Wet Bulb Temperature	Total Air Volume	Outdoor Air Temperature Entering Outdoor Coil														
		48°C					50°C					51.7°C				
		Total Cool Cap.	Comp. Motor Input	Sensible To Total Ratio (S/T)			Total Cool Cap.	Comp. Motor Input	Sensible To Total Ratio (S/T)			Total Cool Cap.	Comp. Motor Input	Sensible To Total Ratio (S/T)		
				Dry Bulb					Dry Bulb					Dry Bulb		
L/s	kW	kW	24°C	27°C	29°C	kW	kW	24°C	27°C	29°C	kW	kW	24°C	27°C	29°C	
17.2°C	1510	19.8	9.12	0.76	1.00	1.00	18.8	9.53	0.76	1.00	1.00	17.9	9.90	0.78	1.00	1.00
	1890	21.8	9.19	0.87	1.00	1.00	20.8	9.60	0.89	1.00	1.00	19.9	9.97	0.91	1.00	1.00
	2265	23.4	9.24	0.97	1.00	1.00	22.3	9.66	0.99	1.00	1.00	21.3	10.03	1.00	1.00	1.00
19.4°C	1510	21.7	9.18	0.51	0.74	0.97	20.5	9.59	0.51	0.75	0.99	19.5	9.96	0.50	0.75	1.00
	1890	22.9	9.23	0.58	0.84	1.00	21.7	9.64	0.58	0.86	1.00	20.6	10.00	0.58	0.88	1.00
	2265	23.9	9.26	0.64	0.95	1.00	22.6	9.67	0.64	0.97	1.00	21.6	10.04	0.65	0.98	1.00
21.7°C	1510	23.8	9.25	0.31	0.52	0.72	22.6	9.67	0.29	0.52	0.73	21.5	10.04	0.28	0.51	0.73
	1890	25.1	9.30	0.34	0.58	0.82	23.8	9.71	0.33	0.59	0.83	22.7	10.08	0.33	0.59	0.85
	2265	25.9	9.30	0.38	0.65	0.92	24.6	9.74	0.37	0.65	0.94	23.5	10.12	0.36	0.66	0.96

RATINGS - STANDARD EFFICIENCY

NOTE – For Temperatures and Capacities not shown in tables, see bulletin – Cooling Unit Rating Table Correction Factor Data in Miscellaneous Engineering Data section.

44 KW STANDARD EFFICIENCY - KCB150S4 (1ST STAGE) - CONSTANT AIR VOLUME

Entering Wet Bulb Temperature	Total Air Volume	Outdoor Air Temperature Entering Outdoor Coil																			
		18.3°C					23.9°C					29.4°C					35°C				
		Total Cool Cap.	Comp. Motor Input	Sensible To Total Ratio (S/T)			Total Cool Cap.	Comp. Motor Input	Sensible To Total Ratio (S/T)			Total Cool Cap.	Comp. Motor Input	Sensible To Total Ratio (S/T)			Total Cool Cap.	Comp. Motor Input	Sensible To Total Ratio (S/T)		
				Dry Bulb					Dry Bulb					Dry Bulb					Dry Bulb		
L/s	kW	kW	24°C	27°C	29°C	kW	kW	24°C	27°C	29°C	kW	kW	24°C	27°C	29°C	kW	kW	24°C	27°C	29°C	
17.2°C	1795	19.8	2.85	.71	.86	1.00	18.5	3.16	.71	.88	1.00	17.2	3.49	.72	.91	1.00	15.7	3.87	.72	.93	1.00
	2075	20.5	2.86	.74	.93	1.00	19.3	3.17	.75	.94	1.00	17.9	3.50	.76	.97	1.00	16.5	3.88	.78	1.00	1.00
	2360	21.2	2.87	.78	.98	1.00	19.9	3.17	.79	1.00	1.00	18.5	3.51	.81	1.00	1.00	17.2	3.88	.83	1.00	1.00
19.4°C	1795	21.3	2.87	.55	.68	.83	20.0	3.17	.54	.69	.84	18.6	3.51	.54	.70	.86	17.1	3.88	.53	.70	.88
	2075	22.0	2.88	.57	.72	.89	20.7	3.18	.57	.73	.91	19.3	3.52	.57	.74	.93	17.7	3.88	.57	.75	.96
	2360	22.7	2.89	.60	.76	.94	21.3	3.19	.60	.77	.97	19.8	3.52	.60	.79	.99	18.3	3.89	.60	.80	1.00
21.7°C	1795	22.7	2.89	.42	.55	.67	21.4	3.19	.40	.54	.67	20.0	3.52	.39	.53	.67	18.5	3.89	.38	.53	.68
	2075	23.6	2.90	.42	.57	.70	22.2	3.20	.42	.57	.71	20.7	3.53	.40	.56	.71	19.1	3.90	.39	.56	.73
	2360	24.1	2.91	.44	.59	.73	22.8	3.21	.43	.59	.75	21.2	3.54	.42	.59	.76	19.7	3.91	.41	.60	.78

44 KW STANDARD EFFICIENCY - KCB150S4 (2ND STAGE) - CONSTANT AIR VOLUME

Entering Wet Bulb Temperature	Total Air Volume	Outdoor Air Temperature Entering Outdoor Coil																			
		29.4°C					35°C					43.3°C					46°C				
		Total Cool Cap.	Comp. Motor Input	Sensible To Total Ratio (S/T)			Total Cool Cap.	Comp. Motor Input	Sensible To Total Ratio (S/T)			Total Cool Cap.	Comp. Motor Input	Sensible To Total Ratio (S/T)			Total Cool Cap.	Comp. Motor Input	Sensible To Total Ratio (S/T)		
				Dry Bulb					Dry Bulb					Dry Bulb					Dry Bulb		
L/s	kW	kW	24°C	27°C	29°C	kW	kW	24°C	27°C	29°C	kW	kW	24°C	27°C	29°C	kW	kW	24°C	27°C	29°C	
17.2°C	1795	37.7	7.59	.73	.90	1.00	34.6	8.42	.74	.92	1.00	29.9	9.86	.78	.99	1.00	28.4	10.39	.79	1.00	1.00
	2075	39.2	7.61	.78	.96	1.00	36.1	8.45	.79	.99	1.00	31.7	9.89	.83	1.00	1.00	30.3	10.43	.85	1.00	1.00
	2360	40.5	7.64	.82	1.00	1.00	37.6	8.47	.84	1.00	1.00	33.4	9.92	.89	1.00	1.00	31.9	10.44	.91	1.00	1.00
19.4°C	1795	40.6	7.63	.55	.71	.86	37.5	8.46	.55	.72	.88	32.6	9.91	.56	.77	.91	30.9	10.43	.56	.78	.93
	2075	42.1	7.66	.58	.75	.92	38.8	8.49	.58	.77	.95	33.8	9.93	.60	.83	.98	32.0	10.45	.60	.84	.99
	2360	43.3	7.69	.61	.80	.98	40.0	8.51	.61	.81	1.00	34.8	9.94	.63	.89	1.00	32.9	10.47	.64	.90	1.00
21.7°C	1795	43.6	7.68	.40	.55	.69	40.4	8.51	.39	.54	.70	35.5	9.96	.37	.56	.69	33.7	10.48	.36	.56	.70
	2075	45.0	7.71	.42	.58	.73	41.7	8.54	.40	.58	.75	36.7	9.98	.39	.61	.75	34.9	10.50	.38	.61	.75
	2360	46.2	7.73	.43	.61	.77	42.9	8.56	.42	.61	.79	37.7	10.00	.41	.64	.79	35.9	10.53	.40	.65	.81

Entering Wet Bulb Temperature	Total Air Volume	Outdoor Air Temperature Entering Outdoor Coil																	
		48°C					50°C					51.7°C							
		Total Cool Cap.	Comp. Motor Input	Sensible To Total Ratio (S/T)			Total Cool Cap.	Comp. Motor Input	Sensible To Total Ratio (S/T)			Total Cool Cap.	Comp. Motor Input	Sensible To Total Ratio (S/T)					
				Dry Bulb					Dry Bulb					Dry Bulb					
L/s	kW	kW	24°C	27°C	29°C	kW	kW	24°C	27°C	29°C	kW	kW	24°C	27°C	29°C				
17.2°C	1795	27.0	10.80	.78	1.00	1.00	25.8	11.23	.79	1.00	1.00	25.2	11.60	.81	1.00	1.00			
	2075	28.8	10.84	.84	1.00	1.00	27.6	11.26	.86	1.00	1.00	27.0	11.63	.88	1.00	1.00			
	2360	30.3	10.86	.90	1.00	1.00	29.2	11.29	.92	1.00	1.00	28.5	11.66	.96	1.00	1.00			
19.4°C	1795	29.6	10.84	.54	.75	.96	28.3	11.27	.54	.76	.98	27.1	11.62	.56	.81	.97			
	2075	30.7	10.86	.58	.82	1.00	29.4	11.29	.58	.83	1.00	28.2	11.66	.60	.88	1.00			
	2360	31.5	10.88	.62	.88	1.00	30.2	11.30	.62	.89	1.00	29.0	11.67	.64	.95	1.00			
21.7°C	1795	32.2	10.90	.34	.54	.73	30.9	11.32	.34	.54	.74	29.9	11.68	.34	.57	.72			
	2075	33.4	10.91	.37	.58	.79	32.0	11.33	.36	.58	.80	30.9	11.70	.36	.61	.78			
	2360	34.3	10.93	.39	.62	.85	32.8	11.34	.38	.62	.87	31.7	11.72	.38	.66	.84			

RATINGS - STANDARD EFFICIENCY

NOTE – For Temperatures and Capacities not shown in tables, see bulletin – Cooling Unit Rating Table Correction Factor Data in Miscellaneous Engineering Data section.

26 KW STANDARD EFFICIENCY - KCB092S4M (1ST STAGE) - MSAV® (MULTI-STAGE AIR VOLUME) SUPPLY AIR BLOWER

Entering Wet Bulb Temperature	Total Air Volume	Outdoor Air Temperature Entering Outdoor Coil																							
		18.3°C						23.9°C						29.4°C						35°C					
		Total Cool Cap.	Comp. Motor Input	Sensible To Total Ratio (S/T)			Total Cool Cap.	Comp. Motor Input	Sensible To Total Ratio (S/T)			Total Cool Cap.	Comp. Motor Input	Sensible To Total Ratio (S/T)			Total Cool Cap.	Comp. Motor Input	Sensible To Total Ratio (S/T)						
				Dry Bulb					Dry Bulb					Dry Bulb					Dry Bulb						
L/s	kW	kW	24°C	27°C	29°C	kW	kW	24°C	27°C	29°C	kW	kW	24°C	27°C	29°C	kW	kW	24°C	27°C	29°C					
17.2°C	795	14.5	2.11	0.68	0.78	0.88	13.8	2.43	0.68	0.79	0.90	13	2.78	0.69	0.8	0.91	12.3	3.17	0.69	0.81	0.93				
	990	15.5	2.14	0.71	0.83	0.94	14.8	2.46	0.72	0.84	0.96	14	2.81	0.72	0.85	0.97	13.1	3.19	0.73	0.87	0.99				
	1190	16.3	2.15	0.74	0.87	0.99	15.5	2.47	0.75	0.89	1.00	14.6	2.82	0.76	0.90	1.00	13.7	3.21	0.77	0.92	1.00				
19.4°C	795	15.2	2.13	0.55	0.66	0.75	14.5	2.45	0.55	0.66	0.76	13.8	2.8	0.55	0.66	0.77	13.0	3.19	0.55	0.67	0.78				
	990	16.4	2.15	0.57	0.69	0.8	15.6	2.47	0.57	0.69	0.81	14.7	2.83	0.57	0.7	0.82	13.9	3.22	0.57	0.71	0.84				
	1190	17.2	2.17	0.59	0.72	0.84	16.4	2.49	0.59	0.73	0.85	15.5	2.84	0.6	0.74	0.87	14.6	3.23	0.60	0.75	0.89				
21.7°C	795	15.9	2.14	0.43	0.54	0.63	15.2	2.46	0.43	0.54	0.64	14.4	2.82	0.42	0.54	0.64	13.7	3.21	0.42	0.53	0.65				
	990	17.1	2.17	0.44	0.56	0.66	16.3	2.49	0.43	0.56	0.67	15.5	2.84	0.44	0.56	0.68	14.6	3.23	0.43	0.56	0.69				
	1190	18.0	2.18	0.45	0.58	0.7	17.1	2.51	0.44	0.58	0.71	16.3	2.86	0.43	0.58	0.72	15.3	3.25	0.42	0.59	0.73				

26 KW STANDARD EFFICIENCY - KCB092S4M (2ND STAGE) - MSAV® (MULTI-STAGE AIR VOLUME) SUPPLY AIR BLOWER

Entering Wet Bulb Temperature	Total Air Volume	Outdoor Air Temperature Entering Outdoor Coil																							
		26.7°C						35°C						43.3°C						46°C					
		Total Cool Cap.	Comp. Motor Input	Sensible To Total Ratio (S/T)			Total Cool Cap.	Comp. Motor Input	Sensible To Total Ratio (S/T)			Total Cool Cap.	Comp. Motor Input	Sensible To Total Ratio (S/T)			Total Cool Cap.	Comp. Motor Input	Sensible To Total Ratio (S/T)						
				Dry Bulb					Dry Bulb					Dry Bulb					Dry Bulb						
L/s	kW	kW	24°C	27°C	29°C	kW	kW	24°C	27°C	29°C	kW	kW	24°C	27°C	29°C	kW	kW	24°C	27°C	29°C					
17.2°C	1135	23.9	4.32	0.75	0.89	1.00	21.5	5.27	0.76	0.92	1.00	19.0	6.37	0.79	0.95	1.00	18.2	6.75	.79	.97	1.00				
	1415	25.2	4.34	0.8	0.95	1.00	22.7	5.30	0.82	0.98	1.00	20.3	6.4	0.85	1.00	1.00	19.4	6.78	.86	1.00	1.00				
	1700	26.2	4.36	0.84	0.99	1.00	23.8	5.32	0.87	1.00	1.00	21.3	6.43	0.91	1.00	1.00	20.5	6.81	.92	1.00	1.00				
19.4°C	1135	25.3	4.34	0.58	0.73	0.86	22.9	5.30	0.58	0.74	0.88	20.3	6.4	0.59	0.76	0.92	19.5	6.78	.59	.76	.93				
	1415	26.7	4.36	0.62	0.78	0.92	24.1	5.32	0.62	0.80	0.95	21.4	6.43	0.63	0.83	0.98	20.4	6.80	.63	.83	.99				
	1700	27.6	4.38	0.65	0.82	0.98	25	5.34	0.66	0.85	0.99	22.1	6.44	0.67	0.89	1.00	21.2	6.82	.68	.90	1.00				
21.7°C	1135	26.7	4.36	0.42	0.57	0.70	24.3	5.32	0.42	0.57	0.72	21.6	6.43	0.41	0.58	0.74	20.7	6.81	.41	.58	.74				
	1415	28.1	4.38	0.45	0.61	0.76	25.5	5.35	0.44	0.62	0.78	22.7	6.46	0.44	0.63	0.81	21.7	6.83	.43	.63	.81				
	1700	29.2	4.39	0.46	0.64	0.80	26.5	5.36	0.46	0.65	0.83	23.5	6.47	0.46	0.67	0.87	22.5	6.85	.46	.67	.88				

Entering Wet Bulb Temperature	Total Air Volume	Outdoor Air Temperature Entering Outdoor Coil																	
		48°C						50°C						51.7°C					
		Total Cool Cap.	Comp. Motor Input	Sensible To Total Ratio (S/T)			Total Cool Cap.	Comp. Motor Input	Sensible To Total Ratio (S/T)			Total Cool Cap.	Comp. Motor Input	Sensible To Total Ratio (S/T)					
				Dry Bulb					Dry Bulb					Dry Bulb					
L/s	kW	kW	24°C	27°C	29°C	kW	kW	24°C	27°C	29°C	kW	kW	24°C	27°C	29°C				
17.2°C	1135	17.6	7.04	.80	.97	1.00	16.9	7.34	.81	.98	1.00	16.4	7.61	0.82	0.99	1.00			
	1415	18.8	7.07	.87	1.00	1.00	18.1	7.38	.88	1.00	1.00	17.6	7.65	0.9	1.00	1.00			
	1700	19.8	7.10	.93	1.00	1.00	19.2	7.40	.95	1.00	1.00	18.6	7.68	0.96	1.00	1.00			
19.4°C	1135	18.8	7.08	.59	.77	.94	18.1	7.37	.59	.78	.96	17.4	7.64	0.6	0.8	0.97			
	1415	19.7	7.10	.64	.85	1.00	19.0	7.40	.64	.86	1.00	18.3	7.66	0.65	0.88	1.00			
	1700	20.4	7.11	.68	.91	1.00	19.6	7.42	.69	.93	1.00	19	7.68	0.7	0.94	1.00			
21.7°C	1135	20.0	7.11	.40	.58	.75	19.3	7.41	.40	.59	.76	18.6	7.68	0.4	0.6	0.78			
	1415	21.0	7.13	.43	.63	.82	20.2	7.43	.43	.64	.84	19.6	7.7	0.43	0.65	0.85			
	1700	21.7	7.14	.46	.68	.89	20.9	7.45	.46	.68	.90	20.3	7.72	0.46	0.7	0.92			

RATINGS - STANDARD EFFICIENCY

NOTE – For Temperatures and Capacities not shown in tables, see bulletin – Cooling Unit Rating Table Correction Factor Data in Miscellaneous Engineering Data section.

30 KW STANDARD EFFICIENCY - KCB102S4M (1ST STAGE) - MSAV® (MULTI-STAGE AIR VOLUME) SUPPLY AIR BLOWER

Entering Wet Bulb Temperature	Total Air Volume	Outdoor Air Temperature Entering Outdoor Coil																			
		18.3°C					23.9°C					29.4°C					35°C				
		Total Cool Cap.	Comp. Motor Input	Sensible To Total Ratio (S/T)			Total Cool Cap.	Comp. Motor Input	Sensible To Total Ratio (S/T)			Total Cool Cap.	Comp. Motor Input	Sensible To Total Ratio (S/T)			Total Cool Cap.	Comp. Motor Input	Sensible To Total Ratio (S/T)		
				Dry Bulb					Dry Bulb					Dry Bulb					Dry Bulb		
L/s	kW	kW	24°C	27°C	29°C	kW	kW	24°C	27°C	29°C	kW	kW	24°C	27°C	29°C	kW	kW	24°C	27°C	29°C	
17.2°C	905	13.5	2	0.69	0.8	0.91	12.8	2.23	0.69	0.81	0.93	12.1	2.51	0.7	0.83	0.94	11.4	2.84	0.7	0.84	0.97
	1135	14.4	2	0.73	0.86	0.98	13.6	2.24	0.74	0.87	0.99	12.8	2.53	0.75	0.89	1.00	12	2.86	0.76	0.91	1.00
	1360	15	2	0.77	0.91	1.00	14.2	2.24	0.78	0.93	1.00	13.4	2.54	0.79	0.95	1.00	12.6	2.88	0.81	0.97	1.00
19.4°C	905	14.4	2	0.55	0.67	0.77	13.7	2.24	0.55	0.67	0.78	12.9	2.52	0.55	0.67	0.79	12.1	2.86	0.55	0.68	0.81
	1135	15.3	2	0.58	0.71	0.83	14.5	2.25	0.58	0.71	0.84	13.7	2.54	0.58	0.72	0.86	12.9	2.88	0.59	0.74	0.88
	1360	15.9	1.99	0.60	0.75	0.88	15.1	2.25	0.61	0.76	0.90	14.3	2.55	0.61	0.77	0.92	13.4	2.9	0.62	0.79	0.94
21.7°C	905	15.2	2	0.43	0.54	0.64	14.5	2.25	0.42	0.54	0.64	13.7	2.54	0.42	0.54	0.65	13.0	2.89	0.41	0.54	0.66
	1135	16.1	1.99	0.44	0.56	0.68	15.4	2.25	0.44	0.57	0.69	14.5	2.56	0.43	0.57	0.70	13.7	2.91	0.42	0.57	0.72
	1360	16.9	1.99	0.45	0.59	0.72	16.0	2.25	0.45	0.60	0.74	15.1	2.57	0.44	0.6	0.75	14.2	2.92	0.44	0.61	0.77

30 KW STANDARD EFFICIENCY - KCB102S4M (2ND STAGE) - MSAV® (MULTI-STAGE AIR VOLUME) SUPPLY AIR BLOWER

Entering Wet Bulb Temperature	Total Air Volume	Outdoor Air Temperature Entering Outdoor Coil																			
		26.7°C					35°C					43.3°C					46°C				
		Total Cool Cap.	Comp. Motor Input	Sensible To Total Ratio (S/T)			Total Cool Cap.	Comp. Motor Input	Sensible To Total Ratio (S/T)			Total Cool Cap.	Comp. Motor Input	Sensible To Total Ratio (S/T)			Total Cool Cap.	Comp. Motor Input	Sensible To Total Ratio (S/T)		
				Dry Bulb					Dry Bulb					Dry Bulb					Dry Bulb		
L/s	kW	kW	24°C	27°C	29°C	kW	kW	24°C	27°C	29°C	kW	kW	24°C	27°C	29°C	kW	kW	24°C	27°C	29°C	
17.2°C	1285	27.3	4.82	0.77	0.92	1.00	24.7	5.82	0.79	0.95	1.00	22	7.01	0.82	0.99	1.00	21.1	7.42	.82	1.00	1.00
	1605	28.7	4.84	0.83	0.99	1.00	26.1	5.86	0.86	1.00	1.00	23.5	7.07	0.89	1.00	1.00	22.7	7.50	.90	1.00	1.00
	1925	30	4.86	0.89	1.00	1.00	27.5	5.9	0.92	1.00	1.00	24.6	7.12	0.96	1.00	1.00	23.8	7.55	.98	1.00	1.00
19.4°C	1285	29.1	4.85	0.6	0.75	0.89	26.4	5.87	0.6	0.77	0.92	23.5	7.08	0.61	0.80	0.96	22.5	7.49	.61	.80	.97
	1605	30.4	4.87	0.64	0.81	0.97	27.5	5.9	0.64	0.84	1.00	24.4	7.11	0.66	0.87	1.00	23.4	7.53	.66	.88	1.00
	1925	31.3	4.87	0.67	0.87	1.00	28.3	5.92	0.69	0.9	1.00	25.1	7.15	0.71	0.95	1.00	24.1	7.57	.71	.96	1.00
21.7°C	1285	30.8	4.87	0.44	0.58	0.72	28	5.91	0.43	0.59	0.75	25	7.14	0.43	0.6	0.77	24.0	7.56	.42	.60	.78
	1605	32.2	4.89	0.46	0.63	0.79	29.2	5.94	0.45	0.64	0.82	26	7.18	0.45	0.66	0.85	24.9	7.60	.45	.66	.86
	1925	33.1	4.90	0.48	0.67	0.85	30.1	5.97	0.47	0.69	0.88	26.7	7.21	0.48	0.71	0.93	25.5	7.62	.47	.71	.94

Entering Wet Bulb Temperature	Total Air Volume	Outdoor Air Temperature Entering Outdoor Coil														
		48°C					50°C					51.7°C				
		Total Cool Cap.	Comp. Motor Input	Sensible To Total Ratio (S/T)			Total Cool Cap.	Comp. Motor Input	Sensible To Total Ratio (S/T)			Total Cool Cap.	Comp. Motor Input	Sensible To Total Ratio (S/T)		
				Dry Bulb					Dry Bulb					Dry Bulb		
L/s	kW	kW	24°C	27°C	29°C	kW	kW	24°C	27°C	29°C	kW	kW	24°C	27°C	29°C	
17.2°C	1285	20.4	7.74	.83	1.00	1.00	19.8	8.09	.84	1.00	1.00	19.2	8.38	0.86	1.00	1.00
	1605	22.0	7.83	.92	1.00	1.00	21.2	8.16	.93	1.00	1.00	20.6	8.46	0.95	1.00	1.00
	1925	23.1	7.88	.99	1.00	1.00	22.3	8.22	1.00	1.00	1.00	21.6	8.51	1.00	1.00	1.00
19.4°C	1285	21.7	7.81	.61	.81	.99	20.9	8.14	.61	.82	1.00	20.3	8.43	0.62	0.84	1.00
	1605	22.6	7.85	.67	.90	1.00	21.7	8.18	.67	.91	1.00	21.0	8.48	0.69	0.93	1.00
	1925	23.3	7.89	.72	.97	1.00	22.5	8.22	.73	.99	1.00	21.7	8.52	0.75	1.00	1.00
21.7°C	1285	23.2	7.88	.42	.61	.79	22.4	8.22	.42	.61	.80	21.6	8.5	0.42	0.62	0.82
	1605	24.1	7.93	.44	.67	.88	23.2	8.26	.44	.67	.89	22.5	8.56	0.45	0.69	0.91
	1925	24.7	7.96	.47	.72	.96	23.9	8.30	.47	.73	.97	23.1	8.59	0.48	0.75	0.99

RATINGS - STANDARD EFFICIENCY

NOTE – For Temperatures and Capacities not shown in tables, see bulletin – Cooling Unit Rating Table Correction Factor Data in Miscellaneous Engineering Data section.

44 KW STANDARD EFFICIENCY - KCB150S4M (1ST STAGE) - MSAV® (MULTI-STAGE AIR VOLUME) SUPPLY AIR BLOWER

Entering Wet Bulb Temperature	Total Air Volume	Outdoor Air Temperature Entering Outdoor Coil																			
		18.3°C					23.9°C					29.4°C					35°C				
		Total Cool Cap.	Comp. Motor Input	Sensible To Total Ratio (S/T)			Total Cool Cap.	Comp. Motor Input	Sensible To Total Ratio (S/T)			Total Cool Cap.	Comp. Motor Input	Sensible To Total Ratio (S/T)			Total Cool Cap.	Comp. Motor Input	Sensible To Total Ratio (S/T)		
				Dry Bulb					Dry Bulb					Dry Bulb					Dry Bulb		
L/s	kW	kW	24°C	27°C	29°C	kW	kW	24°C	27°C	29°C	kW	kW	24°C	27°C	29°C	kW	kW	24°C	27°C	29°C	
17.2°C	1208	18.8	2.96	0.69	0.8	0.9	18.0	3.29	0.69	0.8	0.92	17.1	3.64	0.69	0.82	0.93	16.1	4.03	0.70	0.83	0.96
	1510	20.0	2.98	0.72	0.85	0.97	19.1	3.30	0.73	0.87	0.99	18.2	3.66	0.74	0.88	1.00	17.1	4.05	0.75	0.90	1.00
	1642	20.5	2.99	0.74	0.88	1.00	19.6	3.31	0.75	0.89	1.00	18.6	3.66	0.76	0.91	1.00	17.5	4.05	0.77	0.93	1.00
19.4°C	1208	20.1	2.98	0.55	0.66	0.77	19.3	3.30	0.55	0.66	0.77	18.3	3.66	0.55	0.67	0.78	17.4	4.05	0.55	0.68	0.80
	1510	21.3	3.00	0.57	0.7	0.82	20.5	3.32	0.58	0.71	0.83	19.5	3.67	0.58	0.72	0.85	18.3	4.06	0.58	0.73	0.86
	1642	21.8	3.01	0.58	0.72	0.84	20.8	3.33	0.59	0.73	0.86	19.8	3.68	0.59	0.74	0.87	18.7	4.07	0.60	0.75	0.89
21.7°C	1208	21.5	3.00	0.44	0.54	0.64	20.5	3.32	0.43	0.53	0.64	19.6	3.67	0.42	0.54	0.64	18.5	4.06	0.42	0.53	0.65
	1510	22.7	3.03	0.44	0.56	0.67	21.8	3.34	0.44	0.56	0.68	20.8	3.69	0.43	0.57	0.69	19.7	4.08	0.43	0.57	0.70
	1642	23.2	3.03	0.44	0.57	0.69	22.2	3.35	0.44	0.57	0.70	21.1	3.70	0.44	0.58	0.71	20.0	4.09	0.44	0.58	0.72

44 KW STANDARD EFFICIENCY - KCB150S4M (2ND STAGE) - MSAV® (MULTI-STAGE AIR VOLUME) SUPPLY AIR BLOWER

Entering Wet Bulb Temperature	Total Air Volume	Outdoor Air Temperature Entering Outdoor Coil																			
		29.4°C					35°C					43.3°C					46°C				
		Total Cool Cap.	Comp. Motor Input	Sensible To Total Ratio (S/T)			Total Cool Cap.	Comp. Motor Input	Sensible To Total Ratio (S/T)			Total Cool Cap.	Comp. Motor Input	Sensible To Total Ratio (S/T)			Total Cool Cap.	Comp. Motor Input	Sensible To Total Ratio (S/T)		
				Dry Bulb					Dry Bulb					Dry Bulb					Dry Bulb		
L/s	kW	kW	24°C	27°C	29°C	kW	kW	24°C	27°C	29°C	kW	kW	24°C	27°C	29°C	kW	kW	24°C	27°C	29°C	
17.2°C	1795	40.1	7.33	0.76	0.91	1.00	36.8	8.56	0.78	0.94	1.00	33.2	10.04	0.81	0.98	1.00	31.9	10.57	.81	.99	1.00
	2075	41.4	7.38	0.8	0.96	1.00	38.0	8.60	0.82	0.99	1.00	34.4	10.09	0.85	1.00	1.00	33.3	10.63	.86	1.00	1.00
	2360	42.6	7.41	0.84	0.99	1.00	39.2	8.65	0.86	1.00	1.00	35.9	10.14	0.9	1.00	1.00	34.7	10.69	.91	1.00	1.00
19.4°C	1795	42.7	7.42	0.59	0.74	0.87	39.2	8.65	0.6	0.76	0.90	35.5	10.13	0.61	0.79	0.95	34.2	10.67	.61	.79	.96
	2075	44	7.46	0.62	0.78	0.92	40.4	8.69	0.63	0.8	0.96	36.5	10.18	0.64	0.83	0.99	35.1	10.70	.64	.84	1.00
	2360	45.1	7.50	0.64	0.81	0.97	41.4	8.72	0.65	0.84	1.00	37.3	10.2	0.67	0.87	1.00	35.9	10.73	.67	.88	1.00
21.7°C	1795	45.2	7.50	0.44	0.58	0.72	41.7	8.73	0.44	0.59	0.73	37.7	10.23	0.44	0.6	0.76	36.5	10.76	.43	.60	.76
	2075	46.6	7.55	0.46	0.61	0.75	42.9	8.78	0.45	0.62	0.78	38.8	10.27	0.45	0.63	0.81	37.4	10.80	.45	.63	.81
	2360	47.7	7.60	0.46	0.63	0.79	43.9	8.82	0.46	0.65	0.82	39.7	10.31	0.46	0.66	0.85	38.2	10.84	.46	.66	.86

Entering Wet Bulb Temperature	Total Air Volume	Outdoor Air Temperature Entering Outdoor Coil																	
		48°C					50°C					51.7°C							
		Total Cool Cap.	Comp. Motor Input	Sensible To Total Ratio (S/T)			Total Cool Cap.	Comp. Motor Input	Sensible To Total Ratio (S/T)			Total Cool Cap.	Comp. Motor Input	Sensible To Total Ratio (S/T)					
				Dry Bulb					Dry Bulb					Dry Bulb					
L/s	kW	kW	24°C	27°C	29°C	kW	kW	24°C	27°C	29°C	kW	kW	24°C	27°C	29°C				
17.2°C	1795	31.0	11.00	.82	1.00	1.00	30.0	11.45	.83	1.00	1.00	29.3	11.85	0.85	1.00	1.00			
	2075	32.5	11.06	.87	1.00	1.00	31.6	11.50	.88	1.00	1.00	30.8	11.92	0.9	1.00	1.00			
	2360	33.8	11.11	.92	1.00	1.00	32.9	11.56	.93	1.00	1.00	32.0	11.96	0.95	1.00	1.00			
19.4°C	1795	33.2	11.09	.62	.80	.97	32.1	11.54	.62	.80	.98	31.2	11.93	0.63	0.82	0.99			
	2075	34.1	11.12	.65	.84	1.00	33.0	11.57	.65	.86	1.00	32.1	11.97	0.66	0.88	1.00			
	2360	34.8	11.15	.68	.90	1.00	33.8	11.59	.68	.91	1.00	32.9	12.00	0.69	0.93	1.00			
21.7°C	1795	35.4	11.18	.43	.60	.77	34.4	11.63	.43	.61	.78	33.4	12.03	0.43	0.62	0.8			
	2075	36.4	11.22	.45	.64	.82	35.3	11.66	.45	.64	.83	34.3	12.08	0.45	0.65	0.85			
	2360	37.2	11.25	.46	.67	.87	36.0	11.71	.46	.68	.88	35.0	12.10	0.46	0.69	0.9			

RATINGS - HIGH EFFICIENCY

NOTE – For Temperatures and Capacities not shown in tables, see bulletin – Cooling Unit Rating Table Correction Factor Data in Miscellaneous Engineering Data section.

26 KW HIGH EFFICIENCY - KCA092H4 (1ST STAGE) - CONSTANT AIR VOLUME

Entering Wet Bulb Temperature	Total Air Volume	Outdoor Air Temperature Entering Outdoor Coil																			
		18.3°C					23.9°C					29.4°C					35°C				
		Total Cool Cap.	Comp. Motor Input	Sensible To Total Ratio (S/T)			Total Cool Cap.	Comp. Motor Input	Sensible To Total Ratio (S/T)			Total Cool Cap.	Comp. Motor Input	Sensible To Total Ratio (S/T)			Total Cool Cap.	Comp. Motor Input	Sensible To Total Ratio (S/T)		
				Dry Bulb					Dry Bulb					Dry Bulb					Dry Bulb		
L/s	kW	kW	24°C	27°C	29°C	kW	kW	24°C	27°C	29°C	kW	kW	24°C	27°C	29°C	kW	kW	24°C	27°C	29°C	
17.2°C	1135	12.4	1.62	0.7	0.85	1	11.9	1.83	0.71	0.87	1	11.3	2.06	0.72	0.89	1	10.6	2.33	0.74	0.93	1
	1415	13	1.62	0.76	0.95	1	12.5	1.83	0.77	0.98	1	11.8	2.07	0.78	1	1	11.2	2.33	0.81	1	1
	1700	13.6	1.63	0.81	1	1	13	1.84	0.84	1	1	12.5	2.07	0.86	1	1	11.8	2.33	0.9	1	1
19.4°C	1135	13.2	1.62	0.55	0.68	0.81	12.6	1.83	0.56	0.69	0.83	12	2.07	0.56	0.7	0.85	11.3	2.33	0.56	0.72	0.89
	1415	13.8	1.63	0.59	0.74	0.91	13.2	1.84	0.6	0.75	0.94	12.5	2.07	0.6	0.76	0.97	11.8	2.33	0.61	0.78	1
	1700	14.2	1.63	0.61	0.79	1	13.6	1.84	0.63	0.81	1	12.9	2.07	0.63	0.84	1	12.1	2.33	0.65	0.87	1
21.7°C	1135	13.9	1.63	0.41	0.53	0.66	13.3	1.84	0.42	0.53	0.67	12.7	2.07	0.42	0.55	0.68	12	2.33	0.42	0.56	0.7
	1415	14.5	1.63	0.43	0.57	0.72	13.9	1.84	0.44	0.59	0.73	13.2	2.07	0.44	0.59	0.74	12.5	2.33	0.43	0.6	0.76
	1700	15	1.64	0.45	0.61	0.77	14.3	1.85	0.44	0.62	0.79	13.5	2.08	0.45	0.63	0.82	12.8	2.34	0.45	0.64	0.84

26 KW HIGH EFFICIENCY - KCA092H4 (2ND STAGE) - CONSTANT AIR VOLUME

Entering Wet Bulb Temperature	Total Air Volume	Outdoor Air Temperature Entering Outdoor Coil																			
		26.7°C					35°C					43.3°C					46°C				
		Total Cool Cap.	Comp. Motor Input	Sensible To Total Ratio (S/T)			Total Cool Cap.	Comp. Motor Input	Sensible To Total Ratio (S/T)			Total Cool Cap.	Comp. Motor Input	Sensible To Total Ratio (S/T)			Total Cool Cap.	Comp. Motor Input	Sensible To Total Ratio (S/T)		
				Dry Bulb					Dry Bulb					Dry Bulb					Dry Bulb		
L/s	kW	kW	24°C	27°C	29°C	kW	kW	24°C	27°C	29°C	kW	kW	24°C	27°C	29°C	kW	kW	24°C	27°C	29°C	
17.2°C	1135	23.2	3.89	0.72	0.88	1	21.3	4.66	0.74	0.93	1	19.3	5.61	0.76	0.98	1	18.8	5.97	.82	1.00	1.00
	1415	24.3	3.89	0.78	0.99	1	22.5	4.66	0.81	1	1	20.6	5.62	0.86	1	1	20.1	5.96	.91	1.00	1.00
	1700	25.5	3.9	0.85	1	1	23.7	4.67	0.9	1	1	21.6	5.62	0.96	1	1	21.1	5.96	.99	1.00	1.00
19.4°C	1135	24.6	3.9	0.55	0.69	0.84	22.6	4.66	0.57	0.72	0.89	20.5	5.61	0.58	0.74	0.94	19.8	5.96	.61	.81	.94
	1415	25.7	3.9	0.6	0.76	0.95	23.6	4.67	0.61	0.78	0.99	21.3	5.62	0.62	0.83	1	20.6	5.96	.67	.90	1.00
	1700	26.4	3.91	0.63	0.83	1	24.3	4.67	0.65	0.87	1	22	5.62	0.68	0.94	1	21.2	5.97	.73	.99	1.00
21.7°C	1135	26	3.91	0.41	0.53	0.67	24	4.67	0.42	0.56	0.7	21.8	5.62	0.42	0.57	0.72	21.0	5.96	.43	.61	.73
	1415	27.1	3.91	0.43	0.59	0.74	24.9	4.67	0.43	0.6	0.76	22.6	5.62	0.44	0.62	0.8	21.9	5.96	.45	.67	.82
	1700	27.9	3.92	0.45	0.62	0.8	25.6	4.68	0.45	0.64	0.84	23.2	5.62	0.46	0.68	0.91	22.4	5.96	.48	.74	.91

Entering Wet Bulb Temperature	Total Air Volume	Outdoor Air Temperature Entering Outdoor Coil														
		48°C					50°C					51.7°C				
		Total Cool Cap.	Comp. Motor Input	Sensible To Total Ratio (S/T)			Total Cool Cap.	Comp. Motor Input	Sensible To Total Ratio (S/T)			Total Cool Cap.	Comp. Motor Input	Sensible To Total Ratio (S/T)		
				Dry Bulb					Dry Bulb					Dry Bulb		
L/s	kW	kW	24°C	27°C	29°C	kW	kW	24°C	27°C	29°C	kW	kW	24°C	27°C	29°C	
17.2°C	1135	18.2	6.25	0.78	1	1	17.7	6.55	0.80	1	1	17.3	6.81	0.81	1	1
	1415	19.5	6.25	0.90	1	1	18.9	6.54	0.92	1	1	18.4	6.8	0.94	1	1
	1700	20.4	6.25	0.99	1	1	19.8	6.54	1.00	1	1	19.4	6.8	1	1	1
19.4°C	1135	19.2	6.25	0.59	0.76	0.98	18.7	6.55	0.59	0.77	0.99	18.2	6.81	0.6	0.79	1
	1415	20.0	6.25	0.64	0.87	1	19.4	6.54	0.65	0.89	1	18.9	6.8	0.66	0.91	1
	1700	20.5	6.25	0.70	0.98	1	19.9	6.54	0.71	0.99	1	19.4	6.8	0.71	1	1
21.7°C	1135	20.4	6.25	0.42	0.58	0.74	19.8	6.54	0.42	0.58	0.75	19.3	6.8	0.42	0.59	0.76
	1415	21.2	6.24	0.44	0.63	0.84	20.6	6.54	0.44	0.65	0.86	20	6.79	0.45	0.66	0.88
	1700	21.7	6.24	0.47	0.69	0.95	21.1	6.54	0.47	0.70	0.97	20.5	6.79	0.47	0.71	0.99

RATINGS - HIGH EFFICIENCY

NOTE – For Temperatures and Capacities not shown in tables, see bulletin – Cooling Unit Rating Table Correction Factor Data in Miscellaneous Engineering Data section.

30 KW HIGH EFFICIENCY - KCA102H4 (1ST STAGE) - CONSTANT AIR VOLUME

Entering Wet Bulb Temperature	Total Air Volume	Outdoor Air Temperature Entering Outdoor Coil																			
		18.3°C					23.9°C					29.4°C					35°C				
		Total Cool Cap.	Comp. Motor Input	Sensible To Total Ratio (S/T)			Total Cool Cap.	Comp. Motor Input	Sensible To Total Ratio (S/T)			Total Cool Cap.	Comp. Motor Input	Sensible To Total Ratio (S/T)			Total Cool Cap.	Comp. Motor Input	Sensible To Total Ratio (S/T)		
				Dry Bulb					Dry Bulb					Dry Bulb					Dry Bulb		
L/s	kW	kW	24°C	27°C	29°C	kW	kW	24°C	27°C	29°C	kW	kW	24°C	27°C	29°C	kW	kW	24°C	27°C	29°C	
17.2°C	1285	13.8	1.79	0.64	0.82	1	13	2.03	0.65	0.85	1	12.2	2.29	0.66	0.89	1	11.3	2.59	0.67	0.93	1
	1605	14.5	1.8	0.7	0.97	1	13.7	2.04	0.71	0.99	1	12.9	2.3	0.72	1	1	12.1	2.6	0.76	1	1
	1925	15.2	1.81	0.77	1	1	14.4	2.04	0.79	1	1	13.6	2.3	0.83	1	1	12.8	2.6	0.88	1	1
19.4°C	1285	14.7	1.8	0.5	0.63	0.77	13.9	2.04	0.5	0.63	0.79	13.1	2.3	0.51	0.65	0.83	12.1	2.6	0.51	0.66	0.87
	1605	15.4	1.81	0.54	0.68	0.91	14.5	2.04	0.54	0.69	0.95	13.6	2.3	0.54	0.7	0.98	12.7	2.6	0.55	0.72	1
	1925	15.9	1.81	0.56	0.74	1	15	2.05	0.57	0.77	1	14.1	2.31	0.57	0.8	1	13.1	2.6	0.59	0.86	1
21.7°C	1285	15.6	1.81	0.38	0.49	0.61	14.7	2.04	0.37	0.49	0.61	13.9	2.3	0.37	0.5	0.63	13	2.6	0.37	0.5	0.64
	1605	16.3	1.82	0.4	0.53	0.66	15.4	2.05	0.39	0.54	0.68	14.5	2.31	0.38	0.54	0.68	13.5	2.6	0.38	0.55	0.71
	1925	16.8	1.82	0.41	0.56	0.71	15.9	2.05	0.41	0.57	0.74	14.9	2.31	0.4	0.58	0.76	13.9	2.61	0.4	0.58	0.82

30 KW HIGH EFFICIENCY - KCA102H4 (2ND STAGE) - CONSTANT AIR VOLUME

Entering Wet Bulb Temperature	Total Air Volume	Outdoor Air Temperature Entering Outdoor Coil																			
		26.7°C					35°C					43.3°C					46°C				
		Total Cool Cap.	Comp. Motor Input	Sensible To Total Ratio (S/T)			Total Cool Cap.	Comp. Motor Input	Sensible To Total Ratio (S/T)			Total Cool Cap.	Comp. Motor Input	Sensible To Total Ratio (S/T)			Total Cool Cap.	Comp. Motor Input	Sensible To Total Ratio (S/T)		
				Dry Bulb					Dry Bulb					Dry Bulb					Dry Bulb		
L/s	kW	kW	24°C	27°C	29°C	kW	kW	24°C	27°C	29°C	kW	kW	24°C	27°C	29°C	kW	kW	24°C	27°C	29°C	
17.2°C	1285	26.1	4.32	0.73	0.91	1	23.5	5.19	0.75	0.95	1	20.7	6.27	0.77	1	1	20.4	6.89	.81	1.00	1.00
	1605	27.5	4.33	0.79	1	1	25.1	5.2	0.83	1	1	22.4	6.27	0.88	1	1	22.1	6.86	.92	1.00	1.00
	1925	29	4.34	0.87	1	1	26.4	5.2	0.92	1	1	23.7	6.28	0.98	1	1	23.4	6.83	1.00	1.00	1.00
19.4°C	1285	27.9	4.33	0.57	0.71	0.87	25.2	5.2	0.57	0.73	0.91	22.2	6.27	0.57	0.75	0.96	21.7	6.87	.59	.81	.95
	1605	29.1	4.34	0.61	0.78	0.98	26.3	5.2	0.61	0.8	1	23.2	6.27	0.62	0.85	1	22.7	6.84	.65	.91	1.00
	1925	30	4.35	0.64	0.85	1	27.1	5.21	0.66	0.9	1	24	6.28	0.68	0.96	1	23.4	6.82	.72	1.00	1.00
21.7°C	1285	29.6	4.34	0.41	0.56	0.69	26.8	5.21	0.41	0.56	0.71	23.8	6.27	0.39	0.56	0.73	23.4	6.83	.40	.59	.73
	1605	30.9	4.35	0.43	0.6	0.76	28	5.21	0.42	0.61	0.79	24.8	6.27	0.42	0.62	0.82	24.4	6.81	.43	.66	.82
	1925	31.9	4.36	0.45	0.64	0.83	28.8	5.22	0.45	0.65	0.87	25.6	6.28	0.45	0.68	0.94	25.1	6.80	.46	.73	.91

Entering Wet Bulb Temperature	Total Air Volume	Outdoor Air Temperature Entering Outdoor Coil														
		48°C					50°C					51.7°C				
		Total Cool Cap.	Comp. Motor Input	Sensible To Total Ratio (S/T)			Total Cool Cap.	Comp. Motor Input	Sensible To Total Ratio (S/T)			Total Cool Cap.	Comp. Motor Input	Sensible To Total Ratio (S/T)		
				Dry Bulb					Dry Bulb					Dry Bulb		
L/s	kW	kW	24°C	27°C	29°C	kW	kW	24°C	27°C	29°C	kW	kW	24°C	27°C	29°C	
17.2°C	1285	19.5	7.25	0.79	1	1	18.8	7.65	0.80	1	1	18.1	7.63	0.82	1	1
	1605	21.2	7.20	0.91	1	1	20.5	7.58	0.93	1	1	19.5	7.61	0.96	1	1
	1925	22.5	7.18	1	1	1	21.7	7.55	1.00	1	1	20.7	7.62	1	1	1
19.4°C	1285	20.9	7.23	0.57	0.76	0.99	20.1	7.61	0.57	0.78	1.00	19.1	7.62	0.58	0.8	1
	1605	21.9	7.19	0.63	0.88	1.00	21.1	7.58	0.64	0.90	1.00	20	7.62	0.65	0.93	1
	1925	22.6	7.18	0.69	0.98	1.00	21.7	7.53	0.70	1.00	1.00	20.6	7.61	0.71	1	1
21.7°C	1285	22.5	7.18	0.38	0.56	0.74	21.7	7.56	0.37	0.57	0.75	20.5	7.61	0.38	0.58	0.78
	1605	23.5	7.16	0.41	0.62	0.85	22.7	7.51	0.40	0.63	0.87	21.5	7.61	0.41	0.65	0.9
	1925	24.2	7.16	0.44	0.69	0.96	23.4	7.52	0.44	0.70	0.98	22	7.61	0.44	0.72	1

RATINGS - HIGH EFFICIENCY

NOTE – For Temperatures and Capacities not shown in tables, see bulletin – Cooling Unit Rating Table Correction Factor Data in Miscellaneous Engineering Data section.

35 KW HIGH EFFICIENCY - KCA120H4 (1ST STAGE) - CONSTANT AIR VOLUME

Entering Wet Bulb Temperature	Total Air Volume	Outdoor Air Temperature Entering Outdoor Coil																			
		18.3°C					23.9°C					29.4°C					35°C				
		Total Cool Cap.	Comp. Motor Input	Sensible To Total Ratio (S/T)			Total Cool Cap.	Comp. Motor Input	Sensible To Total Ratio (S/T)			Total Cool Cap.	Comp. Motor Input	Sensible To Total Ratio (S/T)			Total Cool Cap.	Comp. Motor Input	Sensible To Total Ratio (S/T)		
				Dry Bulb					Dry Bulb					Dry Bulb					Dry Bulb		
L/s	kW	kW	24°C	27°C	29°C	kW	kW	24°C	27°C	29°C	kW	kW	24°C	27°C	29°C	kW	kW	24°C	27°C	29°C	
17.2°C	1510	17.5	2.32	0.69	0.85	1	16.6	2.63	0.7	0.87	1	15.7	2.99	0.71	0.89	1	14.7	3.39	0.73	0.93	1
	1890	18.3	2.34	0.75	0.95	1	17.4	2.65	0.76	0.98	1	16.5	3	0.78	1	1	15.6	3.4	0.8	1	1
	2265	19	2.36	0.81	1	1	18.2	2.68	0.82	1	1	17.3	3.03	0.85	1	1	16.4	3.43	0.88	1	1
19.4°C	1510	18.5	2.34	0.55	0.67	0.81	17.6	2.66	0.55	0.68	0.83	16.7	3	0.55	0.69	0.85	15.7	3.41	0.56	0.71	0.88
	1890	19.4	2.37	0.58	0.73	0.91	18.4	2.69	0.59	0.74	0.94	17.5	3.03	0.59	0.76	0.97	16.4	3.43	0.6	0.77	0.99
	2265	20	2.38	0.61	0.79	0.99	19	2.7	0.62	0.8	1	18	3.05	0.63	0.83	1	16.9	3.44	0.63	0.86	1
21.7°C	1510	19.6	2.37	0.41	0.54	0.65	18.7	2.69	0.39	0.54	0.66	17.7	3.04	0.41	0.54	0.67	16.7	3.44	0.4	0.55	0.69
	1890	20.5	2.4	0.43	0.57	0.71	19.5	2.72	0.43	0.58	0.73	18.5	3.07	0.42	0.59	0.74	17.4	3.46	0.43	0.59	0.75
	2265	21.1	2.42	0.45	0.61	0.77	20.1	2.74	0.44	0.61	0.78	19	3.09	0.44	0.62	0.8	17.9	3.48	0.44	0.63	0.83

35 KW HIGH EFFICIENCY - KCA120H4 (2ND STAGE) - CONSTANT AIR VOLUME

Entering Wet Bulb Temperature	Total Air Volume	Outdoor Air Temperature Entering Outdoor Coil																			
		26.7°C					35°C					43.3°C					46°C				
		Total Cool Cap.	Comp. Motor Input	Sensible To Total Ratio (S/T)			Total Cool Cap.	Comp. Motor Input	Sensible To Total Ratio (S/T)			Total Cool Cap.	Comp. Motor Input	Sensible To Total Ratio (S/T)			Total Cool Cap.	Comp. Motor Input	Sensible To Total Ratio (S/T)		
				Dry Bulb					Dry Bulb					Dry Bulb					Dry Bulb		
L/s	kW	kW	24°C	27°C	29°C	kW	kW	24°C	27°C	29°C	kW	kW	24°C	27°C	29°C	kW	kW	24°C	27°C	29°C	
17.2°C	1510	32.3	5.61	0.71	0.88	1	29.5	6.8	0.73	0.93	1	26.4	8.29	0.75	0.98	1	24.8	8.44	.82	1.00	1.00
	1890	33.9	5.65	0.77	0.99	1	31	6.82	0.79	1	1	28.2	8.3	0.84	1	1	26.7	8.52	.92	1.00	1.00
	2265	35.4	5.7	0.84	1	1	32.8	6.87	0.88	1	1	29.7	8.31	0.95	1	1	28.1	8.57	1.00	1.00	1.00
19.4°C	1510	34.3	5.67	0.55	0.69	0.84	31.4	6.84	0.56	0.71	0.88	28.2	8.28	0.56	0.73	0.94	26.2	8.49	.60	.82	.96
	1890	35.9	5.72	0.59	0.75	0.95	32.7	6.86	0.6	0.77	0.99	29.4	8.31	0.61	0.82	1	27.3	8.54	.66	.91	1.00
	2265	36.9	5.75	0.62	0.81	1	33.7	6.89	0.63	0.86	1	30.3	8.34	0.66	0.92	1	28.1	8.57	.73	1.00	1.00
21.7°C	1510	36.3	5.72	0.39	0.54	0.67	33.4	6.88	0.4	0.55	0.69	30.1	8.32	0.4	0.56	0.71	28.0	8.57	.41	.61	.74
	1890	37.9	5.78	0.42	0.58	0.73	34.8	6.93	0.43	0.59	0.75	31.3	8.36	0.41	0.61	0.79	29.1	8.61	.44	.67	.83
	2265	39	5.82	0.44	0.62	0.79	35.8	6.96	0.44	0.63	0.84	32.2	8.37	0.44	0.65	0.89	29.9	8.65	.47	.74	.91

Entering Wet Bulb Temperature	Total Air Volume	Outdoor Air Temperature Entering Outdoor Coil																	
		48°C					50°C					51.7°C							
		Total Cool Cap.	Comp. Motor Input	Sensible To Total Ratio (S/T)			Total Cool Cap.	Comp. Motor Input	Sensible To Total Ratio (S/T)			Total Cool Cap.	Comp. Motor Input	Sensible To Total Ratio (S/T)					
				Dry Bulb					Dry Bulb					Dry Bulb					
L/s	kW	kW	24°C	27°C	29°C	kW	kW	24°C	27°C	29°C	kW	kW	24°C	27°C	29°C				
17.2°C	1510	24.5	9.29	0.77	1	1	23.7	9.76	0.78	1	1	23.1	10.2	0.79	1	1			
	1890	26.5	9.28	0.88	1	1	25.6	9.77	0.90	1	1	24.9	10.14	0.92	1	1			
	2265	27.8	9.30	0.99	1	1	27.0	9.76	1	1	1	26.3	10.15	1	1	1			
19.4°C	1510	26.2	9.27	0.57	0.75	0.97	25.3	9.77	0.57	0.75	0.99	24.6	10.2	0.57	0.76	1			
	1890	27.4	9.28	0.62	0.85	1.00	26.4	9.76	0.62	0.87	1.00	25.6	10.18	0.63	0.89	1			
	2265	28.2	9.31	0.67	0.96	1.00	27.3	9.75	0.68	0.98	1.00	26.4	10.16	0.69	0.99	1			
21.7°C	1510	28.1	9.31	0.39	0.56	0.73	27.1	9.75	0.39	0.56	0.73	26.3	10.17	0.39	0.57	0.74			
	1890	29.2	9.29	0.41	0.61	0.82	28.2	9.74	0.41	0.62	0.84	27.4	10.16	0.41	0.62	0.86			
	2265	30.1	9.34	0.44	0.67	0.94	29.1	9.79	0.44	0.68	0.96	28.2	10.18	0.44	0.69	0.97			

RATINGS - HIGH EFFICIENCY

NOTE – For Temperatures and Capacities not shown in tables, see bulletin – Cooling Unit Rating Table Correction Factor Data in Miscellaneous Engineering Data section.

35 KW HIGH EFFICIENCY - KCB120S4M (1ST STAGE) - MSAV® (MULTI-STAGE AIR VOLUME) SUPPLY AIR BLOWER

Entering Wet Bulb Temperature	Total Air Volume	Outdoor Air Temperature Entering Outdoor Coil																			
		18.3°C					23.9°C					29.4°C					35°C				
		Total Cool Cap.	Comp. Motor Input	Sensible To Total Ratio (S/T)			Total Cool Cap.	Comp. Motor Input	Sensible To Total Ratio (S/T)			Total Cool Cap.	Comp. Motor Input	Sensible To Total Ratio (S/T)			Total Cool Cap.	Comp. Motor Input	Sensible To Total Ratio (S/T)		
				Dry Bulb					Dry Bulb					Dry Bulb					Dry Bulb		
L/s	kW	kW	24°C	27°C	29°C	kW	kW	24°C	27°C	29°C	kW	kW	24°C	27°C	29°C	kW	kW	24°C	27°C	29°C	
17.2°C	906	14.9	2.19	0.67	0.77	0.87	14.2	2.51	0.67	0.78	0.89	13.4	2.87	0.68	0.79	0.9	12.6	3.26	0.68	0.8	0.92
	1133	15.9	2.22	0.7	0.82	0.93	15.2	2.54	0.71	0.83	0.95	14.3	2.9	0.72	0.85	0.97	13.5	3.29	0.73	0.86	0.99
	1359	16.7	2.24	0.74	0.87	0.99	15.9	2.56	0.74	0.88	1.00	15.0	2.92	0.75	0.90	1.00	14.1	3.32	0.77	0.92	1.00
19.4°C	906	15.9	2.21	0.54	0.64	0.74	15.1	2.54	0.54	0.65	0.75	14.3	2.9	0.54	0.65	0.76	13.5	3.29	0.54	0.66	0.77
	1133	17.0	2.24	0.56	0.68	0.79	16.1	2.57	0.56	0.68	0.8	15.3	2.93	0.56	0.69	0.81	14.4	3.32	0.57	0.7	0.83
	1359	17.8	2.26	0.58	0.71	0.83	16.9	2.59	0.59	0.72	0.85	16.0	2.95	0.59	0.73	0.87	15.1	3.34	0.59	0.74	0.89
21.7°C	906	16.8	2.24	0.43	0.53	0.62	16.0	2.56	0.42	0.52	0.62	15.2	2.93	0.42	0.52	0.63	14.4	3.32	0.41	0.52	0.63
	1133	18.0	2.26	0.43	0.55	0.65	17.1	2.59	0.43	0.55	0.66	16.2	2.95	0.43	0.55	0.67	15.4	3.35	0.42	0.55	0.68
	1359	18.9	2.28	0.44	0.57	0.69	18.0	2.61	0.44	0.57	0.70	17.0	2.97	0.44	0.58	0.71	16.1	3.37	0.43	0.58	0.72

35 KW HIGH EFFICIENCY - KCB120S4M (2ND STAGE) - MSAV® (MULTI-STAGE AIR VOLUME) SUPPLY AIR BLOWER

Entering Wet Bulb Temperature	Total Air Volume	Outdoor Air Temperature Entering Outdoor Coil																			
		26.7°C					35°C					43.3°C					46°C				
		Total Cool Cap.	Comp. Motor Input	Sensible To Total Ratio (S/T)			Total Cool Cap.	Comp. Motor Input	Sensible To Total Ratio (S/T)			Total Cool Cap.	Comp. Motor Input	Sensible To Total Ratio (S/T)			Total Cool Cap.	Comp. Motor Input	Sensible To Total Ratio (S/T)		
				Dry Bulb					Dry Bulb					Dry Bulb					Dry Bulb		
L/s	kW	kW	24°C	27°C	29°C	kW	kW	24°C	27°C	29°C	kW	kW	24°C	27°C	29°C	kW	kW	24°C	27°C	29°C	
17.2°C	1285	30	5.47	0.74	0.88	1.00	27.3	6.63	0.76	0.91	1.00	24.3	7.96	0.78	0.95	1.00	23.3	8.42	.78	.96	1.00
	1605	31.7	5.52	0.79	0.95	1.00	28.8	6.68	0.82	0.98	1.00	25.8	8.01	0.85	1.00	1.00	24.9	8.47	.86	1.00	1.00
	1925	33	5.55	0.84	1.00	1.00	30.2	6.72	0.87	1.00	1.00	27.3	8.06	0.91	1.00	1.00	26.3	8.52	.93	1.00	1.00
19.4°C	1285	32.1	5.53	0.58	0.72	0.85	29.3	6.69	0.58	0.73	0.87	26.2	8.02	0.59	0.76	0.91	25.1	8.48	.58	.76	.92
	1605	33.8	5.57	0.61	0.77	0.92	30.8	6.73	0.62	0.79	0.95	27.5	8.06	0.63	0.83	0.99	26.3	8.52	.63	.83	1.00
	1925	35.1	5.59	0.65	0.82	0.98	31.9	6.76	0.66	0.85	1.00	28.4	8.09	0.68	0.89	1.00	27.2	8.55	.68	.90	1.00
21.7°C	1285	34.1	5.57	0.43	0.57	0.69	31.2	6.74	0.43	0.57	0.71	28	8.07	0.42	0.58	0.73	26.9	8.53	.41	.58	.73
	1605	35.9	5.61	0.45	0.6	0.75	32.8	6.78	0.44	0.61	0.77	29.4	8.11	0.44	0.63	0.8	28.2	8.57	.44	.63	.81
	1925	37.2	5.63	0.46	0.64	0.8	34	6.8	0.46	0.65	0.83	30.4	8.13	0.46	0.67	0.87	29.2	8.59	.46	.67	.88

Entering Wet Bulb Temperature	Total Air Volume	Outdoor Air Temperature Entering Outdoor Coil																	
		48°C					50°C					51.7°C							
		Total Cool Cap.	Comp. Motor Input	Sensible To Total Ratio (S/T)			Total Cool Cap.	Comp. Motor Input	Sensible To Total Ratio (S/T)			Total Cool Cap.	Comp. Motor Input	Sensible To Total Ratio (S/T)					
				Dry Bulb					Dry Bulb					Dry Bulb					
L/s	kW	kW	24°C	27°C	29°C	kW	kW	24°C	27°C	29°C	kW	kW	24°C	27°C	29°C				
17.2°C	1285	22.5	8.77	.79	.97	1.00	21.7	9.15	.80	.99	1.00	21	9.48	0.82	1.00	1.00			
	1605	24.1	8.83	.87	1.00	1.00	23.3	9.21	.88	1.00	1.00	22.7	9.54	0.9	1.00	1.00			
	1925	25.5	8.88	.94	1.00	1.00	24.8	9.25	.95	1.00	1.00	24	9.58	0.97	1.00	1.00			
19.4°C	1285	24.3	8.84	.59	.77	.94	23.4	9.21	.59	.77	.95	22.6	9.54	0.6	0.79	0.97			
	1605	25.4	8.88	.64	.84	1.00	24.5	9.24	.64	.85	1.00	23.7	9.57	0.66	0.87	1.00			
	1925	26.3	8.90	.68	.92	1.00	25.4	9.27	.69	.93	1.00	24.5	9.59	0.71	0.95	1.00			
21.7°C	1285	26.0	8.89	.41	.58	.74	25.1	9.26	.41	.58	.75	24.4	9.59	0.41	0.59	0.77			
	1605	27.3	8.93	.44	.63	.82	26.4	9.30	.43	.64	.83	25.6	9.62	0.44	0.65	0.85			
	1925	28.2	8.95	.46	.68	.89	27.3	9.32	.46	.69	.91	26.3	9.64	0.46	0.7	0.93			

BLOWER DATA

092S STANDARD EFFICIENCY BELT DRIVE BLOWER – BASE UNIT

BLOWER TABLE INCLUDES RESISTANCE FOR BASE UNIT ONLY (NO HEAT SECTION) WITH DRY INDOOR COIL AND AIR FILTERS IN PLACE. FOR ALL UNITS ADD:

- 1 – Wet indoor coil air resistance of selected unit.
- 2 – Any factory installed options air resistance (heat section, economizer, etc.)
- 3 – Any field installed accessories air resistance (duct resistance, diffuser, etc.)

Then determine from blower table blower motor output required.

See page 33 for blower motors and drives.

See page 33 for wet coil and option/accessory air resistance data.

MINIMUM AIR VOLUME REQUIRED FOR USE WITH OPTIONAL ELECTRIC HEAT - Maximum Static Pressure - 500 Pa (2.0 in. w.g.)

5.7 kW, 11.5 kW, 17.2 kW, 23 kW and 34.5 kW - 1320 L/s (2800 cfm)

Air Volume		TOTAL STATIC PRESSURE - Pa (Inches Water Gauge)																				
		50 (0.20)			100 (0.40)			150 (0.60)			200 (0.80)			250 (1.00)			300 (1.20)			350 (1.40)		
L/s	cfm	rev/min	kW	BHP	rev/min	kW	BHP	rev/min	kW	BHP	rev/min	kW	BHP	rev/min	kW	BHP	rev/min	kW	BHP	rev/min	kW	BHP
825	1750	608	0.04	0.05	651	0.02	0.03	696	0.04	0.06	744	0.16	0.22	794	0.45	0.60	845	0.71	0.95	894	0.93	1.24
945	2000	615	0.05	0.07	657	0.04	0.05	702	0.07	0.10	748	0.27	0.36	797	0.54	0.72	846	0.78	1.05	892	0.97	1.30
1062	2250	624	0.07	0.09	664	0.05	0.07	707	0.10	0.14	753	0.37	0.50	800	0.63	0.84	847	0.86	1.15	892	1.03	1.38
1180	2500	632	0.08	0.11	672	0.07	0.09	714	0.22	0.29	758	0.48	0.64	803	0.72	0.97	849	0.94	1.26	893	1.10	1.48
1298	2750	641	0.10	0.13	680	0.08	0.11	721	0.34	0.45	763	0.58	0.78	807	0.81	1.09	852	1.02	1.37	896	1.18	1.58
1416	3000	651	0.11	0.15	689	0.22	0.29	728	0.46	0.61	770	0.69	0.93	812	0.92	1.23	856	1.11	1.49	901	1.27	1.70
1534	3250	661	0.13	0.17	698	0.34	0.46	737	0.58	0.78	777	0.81	1.09	819	1.03	1.38	862	1.22	1.63	908	1.37	1.84
1652	3500	672	0.27	0.36	708	0.48	0.65	746	0.71	0.95	786	0.93	1.25	827	1.14	1.53	870	1.33	1.78	916	1.48	1.99
1770	3750	684	0.42	0.56	719	0.63	0.85	756	0.85	1.14	795	1.07	1.43	836	1.27	1.7	880	1.45	1.95	927	1.61	2.16
1888	4000	697	0.58	0.78	731	0.78	1.05	768	1.00	1.34	807	1.21	1.62	848	1.41	1.89	892	1.59	2.13	940	1.75	2.34
2006	4250	710	0.75	1.0	745	0.95	1.27	781	1.16	1.55	819	1.37	1.83	861	1.56	2.09	906	1.74	2.33	954	1.90	2.55

Air Volume		TOTAL STATIC PRESSURE - Pa (Inches Water Gauge)																				
		400 (1.60)			450 (1.80)			500 (2.00)			550 (2.20)			600 (2.40)			650 (2.60)					
L/s	cfm	rev/min	kW	BHP	rev/min	kW	BHP	rev/min	kW	BHP	rev/min	kW	BHP	rev/min	kW	BHP	rev/min	kW	BHP	rev/min	kW	BHP
825	1750	934	1.03	1.38	978	1.10	1.47	1047	1.24	1.66	1120	1.41	1.89	1179	1.60	2.15	1230	1.79	2.40			
945	2000	933	1.08	1.45	977	1.16	1.55	1049	1.31	1.75	1124	1.49	2.00	1181	1.66	2.23	1234	1.84	2.47			
1062	2250	934	1.14	1.53	979	1.23	1.65	1051	1.39	1.86	1126	1.58	2.12	1183	1.76	2.36	1238	1.95	2.62			
1180	2500	936	1.22	1.63	983	1.31	1.75	1052	1.46	1.96	1124	1.66	2.22	1184	1.86	2.49	1241	2.07	2.77			
1298	2750	940	1.30	1.74	989	1.40	1.88	1053	1.55	2.08	1121	1.75	2.34	1185	1.96	2.63	1244	2.19	2.93			
1416	3000	947	1.40	1.87	996	1.51	2.02	1055	1.65	2.21	1120	1.84	2.47	1186	2.07	2.78	1248	2.31	3.10			
1534	3250	955	1.50	2.01	1004	1.62	2.17	1059	1.76	2.36	1122	1.95	2.62	1189	2.19	2.94	1252	2.45	3.28			
1652	3500	965	1.62	2.17	1013	1.74	2.33	1065	1.88	2.52	1126	2.08	2.79	1193	2.33	3.12	1257	2.59	3.47			
1770	3750	976	1.75	2.34	1023	1.87	2.51	1073	2.02	2.71	1133	2.22	2.98	1198	2.48	3.32	1263	2.74	3.67			
1888	4000	988	1.89	2.53	1034	2.02	2.71	1083	2.17	2.91	1141	2.38	3.19	1205	2.63	3.53	1270	2.90	3.89			
2006	4250	1001	2.04	2.74	1046	2.19	2.93	1094	2.34	3.14	1151	2.55	3.42	1214	2.80	3.76	1278	3.07	4.12			

BLOWER DATA

092H AND 102H HIGH EFFICIENCY BELT DRIVE BLOWER – BASE UNIT

BLOWER TABLE INCLUDES RESISTANCE FOR BASE UNIT ONLY (NO HEAT SECTION) WITH DRY INDOOR COIL AND AIR FILTERS IN PLACE. FOR ALL UNITS ADD:

- 1 – Wet indoor coil air resistance of selected unit.
- 2 – Any factory installed options air resistance (heat section, economizer, etc.)
- 3 – Any field installed accessories air resistance (duct resistance, diffuser, etc.)

Then determine from blower table blower motor output required.

See page 33 for blower motors and drives.

See page 33 for wet coil and option/accessory air resistance data.

MINIMUM AIR VOLUME REQUIRED FOR USE WITH OPTIONAL ELECTRIC HEAT - Maximum Static Pressure - 500 Pa (2.0 in. w.g.)

5.7 kW, 11.5 kW, 17.2 kW, 23 kW and 34.5 kW - 1320 L/s (2800 cfm)

Air Volume		TOTAL STATIC PRESSURE - Pa (Inches Water Gauge)																				
		50 (0.20)			100 (0.40)			150 (0.60)			200 (0.80)			250 (1.00)			300 (1.20)			350 (1.40)		
L/s	cfm	rev/min	kW	BHP	rev/min	kW	BHP	rev/min	kW	BHP	rev/min	kW	BHP	rev/min	kW	BHP	rev/min	kW	BHP	rev/min	kW	BHP
825	1750	481	0.16	0.21	549	0.30	0.4	618	0.43	0.57	688	0.52	0.70	758	0.61	0.82	824	0.69	0.93	885	0.81	1.08
945	2000	493	0.22	0.29	561	0.35	0.47	629	0.48	0.64	700	0.57	0.77	768	0.67	0.90	832	0.76	1.02	892	0.87	1.17
1062	2250	507	0.28	0.37	574	0.42	0.56	643	0.54	0.72	712	0.64	0.86	779	0.74	0.99	842	0.84	1.13	900	0.95	1.28
1180	2500	521	0.34	0.46	588	0.48	0.64	657	0.60	0.81	727	0.71	0.95	792	0.81	1.09	853	0.93	1.24	909	1.04	1.40
1298	2750	537	0.42	0.56	604	0.55	0.74	674	0.68	0.91	743	0.79	1.06	806	0.90	1.21	865	1.01	1.36	920	1.14	1.53
1416	3000	554	0.50	0.67	622	0.64	0.86	692	0.76	1.02	760	0.88	1.18	822	1.00	1.34	878	1.12	1.50	931	1.25	1.68
1534	3250	572	0.58	0.78	641	0.73	0.98	712	0.86	1.15	778	0.98	1.32	838	1.11	1.49	892	1.24	1.66	943	1.37	1.84
1652	3500	592	0.67	0.90	663	0.84	1.12	733	0.97	1.30	798	1.10	1.47	855	1.23	1.65	907	1.37	1.83	956	1.51	2.02
1770	3750	614	0.78	1.04	687	0.95	1.28	756	1.10	1.47	818	1.23	1.65	872	1.37	1.83	923	1.51	2.02	970	1.66	2.22
1888	4000	639	0.91	1.22	713	1.10	1.48	780	1.24	1.66	838	1.37	1.83	890	1.51	2.02	939	1.66	2.22	984	1.82	2.44
2006	4250	667	1.07	1.43	741	1.26	1.69	805	1.39	1.86	859	1.51	2.02	909	1.66	2.22	956	1.83	2.45	998	2.00	2.68

Air Volume		TOTAL STATIC PRESSURE - Pa (Inches Water Gauge)																	
		400 (1.60)			450 (1.80)			500 (2.00)			550 (2.20)			600 (2.40)			650 (2.60)		
L/s	cfm	rev/min	kW	BHP	rev/min	kW	BHP	rev/min	kW	BHP	rev/min	kW	BHP	rev/min	kW	BHP	rev/min	kW	BHP
825	1750	941	0.92	1.23	991	1.04	1.39	1038	1.15	1.54	1082	1.25	1.68	1124	1.36	1.82	1166	1.45	1.95
945	2000	946	0.99	1.33	995	1.11	1.49	1041	1.24	1.66	1085	1.35	1.81	1126	1.47	1.97	1167	1.58	2.12
1062	2250	953	1.07	1.44	1001	1.20	1.61	1045	1.33	1.78	1088	1.45	1.95	1128	1.58	2.12	1168	1.72	2.30
1180	2500	960	1.17	1.57	1007	1.30	1.74	1050	1.44	1.93	1091	1.57	2.11	1130	1.71	2.29	1170	1.85	2.48
1298	2750	969	1.28	1.71	1014	1.41	1.89	1055	1.55	2.08	1095	1.69	2.27	1133	1.84	2.47	1172	1.98	2.66
1416	3000	979	1.39	1.86	1021	1.54	2.06	1061	1.69	2.26	1099	1.84	2.46	1136	1.98	2.65	1174	2.13	2.85
1534	3250	989	1.51	2.03	1030	1.67	2.24	1068	1.83	2.45	1105	1.98	2.65	1141	2.13	2.85	1178	2.28	3.06
1652	3500	1000	1.66	2.22	1039	1.82	2.44	1076	1.98	2.65	1111	2.13	2.86	1146	2.29	3.07	1183	2.44	3.27
1770	3750	1011	1.81	2.43	1049	1.98	2.65	1084	2.14	2.87	1118	2.31	3.09	1152	2.45	3.29	1189	2.62	3.51
1888	4000	1023	1.98	2.66	1059	2.16	2.89	1093	2.32	3.11	1126	2.48	3.33	1160	2.64	3.54	1197	2.81	3.77
2006	4250	1036	2.18	2.92	1070	2.35	3.15	1103	2.51	3.37	1135	2.68	3.59	1169	2.84	3.81	1207	3.02	4.05

BLOWER DATA

102S AND 120S STANDARD EFFICIENCY BELT DRIVE BLOWER – BASE UNIT

BLOWER TABLE INCLUDES RESISTANCE FOR BASE UNIT ONLY (NO HEAT SECTION) WITH DRY INDOOR COIL AND AIR FILTERS IN PLACE. FOR ALL UNITS ADD:

- 1 – Wet indoor coil air resistance of selected unit.
- 2 – Any factory installed options air resistance (heat section, economizer, etc.)
- 3 – Any field installed accessories air resistance (duct resistance, diffuser, etc.)

Then determine from blower table blower motor output required.

See page 33 for blower motors and drives.

See page 33 for wet coil and option/accessory air resistance data.

MINIMUM AIR VOLUME REQUIRED FOR USE WITH OPTIONAL ELECTRIC HEAT - Maximum Static Pressure - 500 Pa (2.0 in. w.g.)

11.5 kW, 17.2 kW, 23 kW and 34.5 kW - 1320 L/s (2800 cfm)

45.9 kW - 1885 L/s (4000 cfm)

Air Volume		TOTAL STATIC PRESSURE - Pa (Inches Water Gauge)																				
		50 (0.20)			100 (0.40)			150 (0.60)			200 (0.80)			250 (1.00)			300 (1.20)			350 (1.40)		
L/s	cfm	rev/min	kW	BHP	rev/min	kW	BHP	rev/min	kW	BHP	rev/min	kW	BHP	rev/min	kW	BHP	rev/min	kW	BHP	rev/min	kW	BHP
944	2000	593	0.08	0.11	636	0.05	0.07	682	0.07	0.10	731	0.16	0.22	784	0.45	0.60	840	0.72	0.96	898	0.94	1.26
1062	2250	604	0.11	0.15	645	0.08	0.11	690	0.11	0.15	739	0.29	0.39	790	0.55	0.74	846	0.81	1.08	901	1.00	1.34
1180	2500	615	0.14	0.19	655	0.11	0.15	699	0.15	0.20	747	0.41	0.55	797	0.66	0.89	851	0.90	1.20	906	1.07	1.44
1298	2750	626	0.17	0.23	666	0.14	0.19	709	0.28	0.37	755	0.53	0.71	805	0.77	1.03	858	0.98	1.32	912	1.16	1.55
1416	3000	637	0.20	0.27	677	0.18	0.24	719	0.41	0.55	764	0.65	0.87	813	0.88	1.18	866	1.08	1.45	920	1.25	1.67
1534	3250	650	0.23	0.31	688	0.32	0.43	730	0.54	0.73	775	0.78	1.04	823	1.00	1.34	875	1.19	1.60	930	1.35	1.81
1652	3500	663	0.26	0.35	700	0.47	0.63	741	0.69	0.92	786	0.91	1.22	834	1.12	1.50	886	1.31	1.76	942	1.46	1.96
1770	3750	676	0.43	0.57	714	0.63	0.84	754	0.84	1.12	798	1.05	1.41	846	1.25	1.68	899	1.44	1.93	956	1.60	2.14
1888	4000	691	0.59	0.79	728	0.78	1.05	768	0.99	1.33	812	1.20	1.61	860	1.40	1.88	914	1.58	2.12	971	1.75	2.34
2006	4250	706	0.77	1.03	743	0.95	1.28	783	1.16	1.55	827	1.36	1.82	876	1.56	2.09	931	1.74	2.33	987	1.90	2.55
2124	4500	722	0.95	1.27	759	1.13	1.52	799	1.33	1.78	844	1.53	2.05	894	1.72	2.31	949	1.91	2.56	1003	2.08	2.79
2242	4750	739	1.14	1.53	776	1.32	1.77	817	1.51	2.03	862	1.72	2.30	913	1.91	2.56	968	2.10	2.81	1020	2.27	3.04
2360	5000	757	1.34	1.79	794	1.52	2.04	835	1.72	2.30	882	1.91	2.56	934	2.11	2.83	988	2.30	3.08	1036	2.48	3.32

Air Volume		TOTAL STATIC PRESSURE - Pa (Inches Water Gauge)																				
		400 (1.60)			450 (1.80)			500 (2.00)			550 (2.20)			600 (2.40)			650 (2.60)					
L/s	cfm	rev/min	kW	BHP	rev/min	kW	BHP	rev/min	kW	BHP	rev/min	kW	BHP	rev/min	kW	BHP	rev/min	kW	BHP	rev/min	kW	BHP
944	2000	948	1.03	1.38	996	1.10	1.47	1045	1.17	1.57	1092	1.28	1.71	1140	1.43	1.92	1188	1.73	2.32			
1062	2250	953	1.10	1.48	1002	1.17	1.57	1052	1.27	1.70	1100	1.39	1.86	1149	1.56	2.09	1197	1.81	2.42			
1180	2500	959	1.18	1.58	1009	1.25	1.68	1059	1.37	1.83	1108	1.50	2.01	1158	1.69	2.26	1206	1.88	2.52			
1298	2750	966	1.27	1.70	1017	1.35	1.81	1067	1.47	1.97	1117	1.62	2.17	1166	1.82	2.44	1215	2.02	2.71			
1416	3000	975	1.36	1.82	1026	1.46	1.96	1076	1.59	2.13	1126	1.75	2.35	1176	1.96	2.63	1225	2.18	2.92			
1534	3250	985	1.47	1.97	1036	1.58	2.12	1086	1.72	2.31	1136	1.89	2.54	1186	2.11	2.83	1235	2.33	3.13			
1652	3500	997	1.60	2.14	1048	1.72	2.31	1097	1.87	2.51	1147	2.05	2.75	1196	2.27	3.04	1245	2.50	3.35			
1770	3750	1010	1.73	2.32	1060	1.87	2.51	1109	2.03	2.72	1158	2.22	2.98	1207	2.44	3.27	1255	2.67	3.58			
1888	4000	1023	1.89	2.53	1072	2.04	2.73	1121	2.20	2.95	1169	2.40	3.22	1218	2.62	3.51	1266	2.86	3.83			
2006	4250	1037	2.06	2.76	1085	2.22	2.97	1133	2.39	3.20	1181	2.59	3.47	1229	2.80	3.76	1277	3.04	4.08			
2124	4500	1052	2.24	3.00	1098	2.40	3.22	1145	2.58	3.46	1193	2.78	3.73	1241	3.01	4.03	1289	3.24	4.34			
2242	4750	1066	2.44	3.27	1112	2.60	3.49	1158	2.79	3.74	1205	2.99	4.01	1253	3.21	4.30	1301	3.44	4.61			
2360	5000	1081	2.65	3.55	1125	2.82	3.78	1171	3.00	4.02	1218	3.20	4.29	1265	3.42	4.59	1312	3.65	4.89			

BLOWER DATA

120H HIGH EFFICIENCY AND 150S STANDARD EFFICIENCY BELT DRIVE BLOWER – BASE UNIT

BLOWER TABLE INCLUDES RESISTANCE FOR BASE UNIT ONLY (NO HEAT SECTION) WITH DRY INDOOR COIL AND AIR FILTERS IN PLACE. FOR ALL UNITS ADD:

- 1 – Wet indoor coil air resistance of selected unit.
- 2 – Any factory installed options air resistance (heat section, economizer, etc.)
- 3 – Any field installed accessories air resistance (duct resistance, diffuser, etc.)

Then determine from blower table blower motor output required.

See page 33 for blower motors and drives.

See page 33 for wet coil and option/accessory air resistance data.

MINIMUM AIR VOLUME REQUIRED FOR USE WITH OPTIONAL ELECTRIC HEAT - Maximum Static Pressure - 500 Pa (2.0 in. w.g.)

11.5 kW, 17.2 kW, 23 kW and 34.5 kW - 1320 L/s (2800 cfm)

45.9 kW - 1885 L/s (4000 cfm)

Air Volume		TOTAL STATIC PRESSURE - Pa (Inches Water Gauge)																				
		50 (0.20)			100 (0.40)			150 (0.60)			200 (0.80)			250 (1.00)			300 (1.20)			350 (1.40)		
L/s	cfm	rev/min	kW	BHP	rev/min	kW	BHP	rev/min	kW	BHP	rev/min	kW	BHP	rev/min	kW	BHP	rev/min	kW	BHP	rev/min	kW	BHP
944	2000	497	0.19	0.25	558	0.33	0.44	624	0.45	0.60	694	0.55	0.74	764	0.63	0.85	830	0.74	0.99	889	0.87	1.16
1062	2250	511	0.25	0.34	573	0.39	0.52	638	0.51	0.68	708	0.61	0.82	776	0.70	0.94	839	0.81	1.09	896	0.94	1.26
1180	2500	527	0.33	0.44	589	0.46	0.62	654	0.58	0.78	723	0.68	0.91	789	0.78	1.05	850	0.90	1.21	904	1.04	1.39
1298	2750	545	0.41	0.55	606	0.54	0.72	672	0.66	0.88	740	0.77	1.03	804	0.87	1.17	861	1.00	1.34	914	1.14	1.53
1416	3000	564	0.49	0.66	626	0.63	0.84	692	0.75	1.01	759	0.87	1.16	819	0.98	1.32	874	1.11	1.49	924	1.25	1.68
1534	3250	585	0.59	0.79	648	0.73	0.98	714	0.85	1.14	778	0.98	1.31	836	1.10	1.48	887	1.24	1.66	935	1.39	1.86
1652	3500	607	0.69	0.93	672	0.84	1.13	737	0.98	1.31	798	1.10	1.48	852	1.24	1.66	901	1.38	1.85	948	1.53	2.05
1770	3750	632	0.82	1.10	698	0.98	1.31	762	1.12	1.50	819	1.25	1.67	869	1.39	1.86	915	1.53	2.05	961	1.68	2.25
1888	4000	660	0.97	1.30	726	1.13	1.52	787	1.27	1.70	838	1.40	1.87	885	1.54	2.06	930	1.69	2.26	974	1.85	2.48
2006	4250	691	1.14	1.53	755	1.31	1.75	810	1.42	1.91	857	1.54	2.07	901	1.69	2.27	945	1.87	2.50	990	2.04	2.74
2124	4500	724	1.33	1.78	783	1.48	1.98	831	1.58	2.12	874	1.70	2.28	917	1.87	2.50	962	2.05	2.75	1006	2.25	3.02
2242	4750	757	1.53	2.05	809	1.64	2.20	851	1.74	2.33	891	1.87	2.51	935	2.06	2.76	980	2.28	3.05	1025	2.48	3.33
2360	5000	787	1.72	2.31	831	1.81	2.43	870	1.92	2.57	910	2.07	2.78	954	2.28	3.06	1000	2.52	3.38	1046	2.75	3.68
2477	5250	814	1.90	2.55	852	1.98	2.66	889	2.11	2.83	930	2.31	3.09	975	2.54	3.41	1023	2.80	3.76	1070	3.04	4.08
2595	5500	835	2.07	2.78	871	2.17	2.91	909	2.33	3.13	952	2.57	3.44	999	2.84	3.81	1049	3.12	4.18	1096	3.36	4.51
2713	5750	854	2.25	3.01	890	2.38	3.19	930	2.60	3.48	977	2.88	3.86	1027	3.19	4.27	1078	3.48	4.66	1126	3.72	4.99
2831	6000	871	2.43	3.26	910	2.63	3.53	955	2.91	3.90	1006	3.24	4.34	1060	3.58	4.80	1111	3.87	5.19	1158	4.11	5.51
2949	6250	890	2.66	3.57	934	2.94	3.94	985	3.29	4.41	1041	3.66	4.91	1096	4.01	5.38	---	---	---	---	---	---

Air Volume		TOTAL STATIC PRESSURE - Pa (Inches Water Gauge)																		
		400 (1.60)			450 (1.80)			500 (2.00)			550 (2.20)			600 (2.40)			650 (2.60)			
L/s	cfm	rev/min	kW	BHP	rev/min	kW	BHP	rev/min	kW	BHP	rev/min	kW	BHP	rev/min	kW	BHP	rev/min	kW	BHP	
944	2000	943	1.00	1.34	994	1.13	1.52	1045	1.28	1.71	1096	1.41	1.89	1146	1.55	2.08	1197	1.69	2.27	
1062	2250	948	1.08	1.45	998	1.22	1.64	1048	1.37	1.83	1098	1.50	2.01	1149	1.64	2.20	1200	1.79	2.40	
1180	2500	955	1.18	1.58	1003	1.32	1.77	1052	1.46	1.96	1101	1.60	2.14	1152	1.74	2.33	1203	1.89	2.53	
1298	2750	962	1.28	1.72	1010	1.43	1.92	1057	1.57	2.10	1105	1.71	2.29	1154	1.84	2.47	1206	2.00	2.68	
1416	3000	971	1.40	1.88	1017	1.55	2.08	1063	1.69	2.26	1110	1.82	2.44	1158	1.96	2.63	1208	2.11	2.83	
1534	3250	981	1.54	2.06	1026	1.69	2.26	1071	1.83	2.45	1117	1.96	2.63	1163	2.09	2.80	1213	2.24	3.00	
1652	3500	993	1.69	2.26	1037	1.84	2.46	1081	1.98	2.65	1125	2.11	2.83	1171	2.25	3.01	1221	2.39	3.21	
1770	3750	1005	1.84	2.47	1049	2.00	2.68	1092	2.15	2.88	1136	2.28	3.05	1181	2.42	3.24	1231	2.57	3.45	
1888	4000	1018	2.02	2.71	1062	2.19	2.93	1105	2.33	3.12	1149	2.46	3.30	1194	2.60	3.49	1245	2.78	3.72	
2006	4250	1034	2.22	2.98	1077	2.39	3.20	1120	2.53	3.39	1163	2.67	3.58	1210	2.83	3.79	1262	3.01	4.03	
2124	4500	1051	2.44	3.27	1094	2.60	3.49	1137	2.76	3.70	1181	2.90	3.89	1228	3.07	4.11	1281	3.27	4.38	
2242	4750	1070	2.68	3.59	1113	2.85	3.82	1156	3.01	4.03	1201	3.16	4.24	1249	3.33	4.47	1303	3.54	4.75	
2360	5000	1091	2.95	3.95	1135	3.13	4.19	1178	3.28	4.40	1224	3.45	4.62	1272	3.63	4.86	1325	3.83	5.13	
2477	5250	1115	3.25	4.35	1159	3.42	4.59	1203	3.59	4.81	1248	3.75	5.03	1297	3.93	5.27	1350	4.13	5.53	
2595	5500	1142	3.57	4.79	1186	3.75	5.03	1229	3.91	5.24	1275	4.07	5.46	1324	4.24	5.69	---	---	---	
2713	5750	1171	3.92	5.26	1214	4.10	5.49	1258	4.25	5.70	---	---	---	---	---	---	---	---	---	
2831	6000	---	---	---	---	---	---	---	---	---	---	---	---	---	---	---	---	---	---	---
2949	6250	---	---	---	---	---	---	---	---	---	---	---	---	---	---	---	---	---	---	---

BLOWER DATA

FACTORY INSTALLED BELT DRIVE KIT SPECIFICATIONS

Nominal		Maximum		Drive Kit Number	Rev/Min Range	
kW	hp	kW	hp		CAV	MSAVMSAV
1.5	2	1.7	2.3	1	490 - 740	590-890
1.5	2	1.7	2.3	2	665 - 920	800-1105
1.5	2	1.7	2.3	3	660 - 995	795-1195
2.2	3	2.6	3.45	7	610 - 810	730-970
2.2	3	2.6	3.45	8	780 - 1000	940-1200
2.2	3	2.6	3.45	9	845 - 1085	1015-1300
3.7	5	4.3	5.75	10	750 - 945	900-1135
3.7	5	4.3	5.75	11	865 - 1095	1040-1315
3.7	5	4.3	5.75	12	940 - 1190	1125-1425

NOTE - Using total air volume and system static pressure requirements determine from blower performance tables rev/min and motor output required. Maximum usable output of motors furnished are shown. If motors of comparable output are used, be sure to keep within the service factor limitations outlined on the motor nameplate.

NOTE - Units equipped with MSAV® (Multi-Stage Air Volume) option are limited to a motor service factor of 1.0.

POWER EXHAUST FAN PERFORMANCE

Return Air System Static Pressure		Air Volume Exhausted	
Pa	in. w.g.	L/s	cfm
0	0	1498	3175
12	0.05	1394	2955
25	0.10	1267	2685
37	0.15	1137	2410
50	0.20	1022	2165
62	0.25	906	1920
75	0.30	670	1420
87	0.35	566	1200

FACTORY INSTALLED OPTIONS/FIELD INSTALLED ACCESSORY AIR RESISTANCE

Air Volume		Wet Indoor Coil				Electric Heat		Economizer		Filters				Return Air Adaptor Plate	
		092, 102		120, 150						MERV 8		MERV 13			
L/s	cfm	Pa	in. w.g.	Pa	in. w.g.	Pa	in. w.g.	Pa	in. w.g.	Pa	in. w.g.	Pa	in. w.g.	Pa	in. w.g.
826	1750	10	0.04	10	0.04	7	0.03	12	0.05	2	0.01	7	0.03	0	0.00
944	2000	12	0.05	12	0.05	7	0.03	15	0.06	2	0.01	7	0.03	0	0.00
1062	2250	15	0.06	15	0.06	10	0.04	20	0.08	2	0.01	10	0.04	0	0.00
1180	2500	17	0.07	17	0.07	10	0.04	27	0.11	2	0.01	12	0.05	0	0.00
1298	2750	20	0.08	20	0.08	12	0.05	30	0.12	5	0.02	12	0.05	0	0.00
1416	3000	25	0.10	22	0.09	15	0.06	32	0.13	5	0.02	15	0.06	5	0.02
1534	3250	27	0.11	25	0.10	15	0.06	37	0.15	5	0.02	15	0.06	5	0.02
1652	3500	30	0.12	27	0.11	22	0.09	37	0.15	7	0.03	17	0.07	10	0.04
1770	3750	35	0.14	32	0.13	22	0.09	37	0.15	7	0.03	20	0.08	17	0.07
1888	4000	37	0.15	35	0.14	22	0.09	47	0.19	10	0.04	20	0.08	22	0.09
2006	4250	42	0.17	37	0.15	32	0.13	47	0.19	10	0.04	22	0.09	27	0.11
2124	4500	47	0.19	42	0.17	35	0.14	55	0.22	10	0.04	22	0.09	30	0.12
2242	4750	50	0.20	45	0.18	42	0.17	62	0.25	12	0.05	25	0.10	40	0.16
2360	5000	55	0.22	50	0.20	50	0.20	72	0.29	15	0.06	25	0.10	45	0.18
2477	5250	60	0.24	55	0.22	55	0.22	80	0.32	15	0.06	27	0.11	47	0.19
2595	5500	62	0.25	57	0.23	62	0.25	85	0.34	17	0.07	30	0.12	55	0.22
2713	5750	67	0.27	62	0.25	77	0.31	112	0.45	17	0.07	30	0.12	62	0.25
2831	6000	72	0.29	67	0.27	82	0.33	129	0.52	20	0.08	32	0.13	67	0.27

BLOWER DATA

CEILING DIFFUSERS AIR RESISTANCE

Unit Size	RTD11 Step-Down Diffuser								FD11 Flush Diffuser	
	Air Volume		2 Ends Open		1 Side, 2 Ends Open		All Ends & Sides Open			
	Pa	in. w.g.	Pa	in. w.g.	Pa	in. w.g.	Pa	in. w.g.	Pa	in. w.g.
092 Models	1133	2400	52	0.21	45	0.18	37	0.15	35	0.14
	1227	2600	60	0.24	52	0.21	45	0.18	42	0.17
	1321	2800	67	0.27	60	0.24	52	0.21	50	0.20
	1416	3000	80	0.32	72	0.29	62	0.25	62	0.25
	1510	3200	102	0.41	92	0.37	80	0.32	77	0.31
	1604	3400	124	0.50	112	0.45	97	0.39	92	0.37
	1699	3600	152	0.61	134	0.54	119	0.48	109	0.44
102 & 120 Models	1793	3800	182	0.73	157	0.63	142	0.57	127	0.51
	1699	3600	90	0.36	70	0.28	57	0.23	37	0.15
	1793	3800	99	0.40	80	0.32	65	0.26	45	0.18
	1888	4000	109	0.44	90	0.36	72	0.29	52	0.21
	1982	4200	122	0.49	99	0.40	82	0.33	60	0.24
	2076	4400	134	0.54	109	0.44	92	0.37	67	0.27
	2171	4600	149	0.60	122	0.49	104	0.42	77	0.31
	2265	4800	162	0.65	132	0.53	114	0.46	87	0.35
150 Models	2360	5000	172	0.69	144	0.58	124	0.50	97	0.39
	2454	5200	186	0.75	154	0.62	134	0.54	107	0.43
	1982	4200	55	0.22	47	0.19	40	0.16	25	0.10
	2076	4400	70	0.28	60	0.24	50	0.20	30	0.12
	2171	4600	85	0.34	72	0.29	60	0.24	37	0.15
	2265	4800	99	0.40	85	0.34	72	0.29	47	0.19
	2360	5000	114	0.46	97	0.39	85	0.34	57	0.23
	2454	5200	129	0.52	109	0.44	97	0.39	67	0.27
2548	5400	144	0.58	122	0.49	107	0.43	77	0.31	
2643	5600	159	0.64	134	0.54	117	0.47	87	0.35	
2737	5800	174	0.70	147	0.59	127	0.51	97	0.39	

CEILING DIFFUSER AIR THROW DATA

Model No.	Air Volume		¹ Effective Throw Range			
			RTD11 Step-Down		FD11 Flush	
	L/s	cfm	m	ft.	m	ft.
092 Models	1227	2600	7 - 9	24 - 29	6 - 7	19 - 24
	1321	2800	8 - 9	25 - 30	6 - 9	20 - 28
	1416	3000	8 - 10	27 - 33	6 - 9	21 - 29
	1510	3200	9 - 11	28 - 35	7 - 9	22 - 29
	1604	3400	9 - 11	30 - 37	7 - 9	22 - 30
102, 120 Models	1699	3600	8 - 10	25 - 33	7 - 9	22 - 29
	1793	3800	8 - 11	27 - 35	7 - 9	22 - 30
	1888	4000	9 - 11	29 - 37	7 - 10	24 - 33
	1982	4200	10 - 12	32 - 40	8 - 11	26 - 35
	2076	4400	10 - 13	34 - 42	9 - 11	28 - 37
150 Models	2643	5600	12 - 15	39 - 49	9 - 11	28 - 37
	2737	5800	13 - 16	42 - 51	9 - 12	29 - 38
	2831	6000	13 - 17	44 - 54	12 - 15	40 - 50
	2926	6200	14 - 17	45 - 55	13 - 16	42 - 51
	3020	6400	14 - 17	46 - 55	13 - 16	43 - 52
3115	6600	14 - 17	47 - 56	14 - 17	45 - 56	

¹ Throw is the horizontal or vertical distance an air stream travels on leaving the outlet or diffuser before the maximum velocity is reduced to 15 m (50 ft.) per minute. Four sides open.

ELECTRICAL/ELECTRIC HEAT DATA

Model No.		KCB092S4			KCA092H4			KCB102S4			KCA102H4		
¹ Voltage - 50hz 3 Phase with neutral		380/420V			380/420V			380/420V			380/420V		
Compressor 1	Rated Load Amps	6.1			6.1			6			6.1		
	Locked Rotor Amps	41			41			51			43		
Compressor 2	Rated Load Amps	6.1			6.1			6			6.1		
	Locked Rotor Amps	41			41			51			43		
Outdoor Fan Motors (2)	Full Load Amps	1.3			1.3			1.3			1.3		
	(total)	(2.6)			(2.6)			(2.6)			(2.6)		
Power Exhaust (1) 0.25 kW (0.33 HP)	Full Load Amps	1.3			1.3			1.3			1.3		
Indoor Blower Motor	kW	1.5	2.2	3.7	1.5	2.2	3.7	1.5	2.2	3.7	1.5	2.2	3.7
	Full Load Amps	3.6	5.3	8.2	3.6	5.3	8.2	3.6	5.3	8.2	3.6	5.3	8.2
² Maximum Overcurrent Protection	Unit Only	25	25	30	25	25	30	25	25	30	25	25	30
	With 0.25 kW (0.33 HP) Power Exhaust	25	25	30	25	25	30	25	25	30	25	25	30
³ Minimum Circuit Ampacity	Unit Only	20	22	26	20	22	26	20	22	25	20	22	26
	With 0.25 kW (0.33 HP) Power Exhaust	22	23	27	22	23	27	22	23	27	22	23	27

ELECTRIC HEAT DATA

Electric Heat Voltage			420V	420V	420V	420V	420V	420V	420V	420V	420V	420V	420V
² Maximum Overcurrent Protection	Unit+ ⁴ Electric Heat	5.7 kW	25	25	30	25	25	30	25	25	30	25	30
		11.5 kW	25	30	30	25	30	30	25	30	30	25	30
		17.2 kW	35	40	40	35	40	40	35	40	40	35	40
		23 kW	45	50	50	45	50	50	45	50	50	45	50
		34.5 kW	70	70	70	70	70	70	70	70	70	70	70
³ Minimum Circuit Ampacity	Unit+ ⁴ Electric Heat	5.7 kW	20	22	26	20	22	26	20	22	25	20	22
		11.5 kW	25	27	30	25	27	30	25	27	30	25	27
		17.2 kW	35	37	40	35	37	40	35	37	40	35	37
		23 kW	44	47	50	44	47	50	44	47	50	44	47
		34.5 kW	64	66	70	64	66	70	64	66	70	64	66
² Maximum Overcurrent Protection	Unit+ ⁴ Electric Heat and 0.25 kW (0.33 HP)Power Exhaust	5.7 kW	25	25	30	25	25	30	25	25	30	25	30
		11.5 kW	30	30	35	30	30	35	30	30	35	30	35
		17.2 kW	40	40	45	40	40	45	40	40	45	40	45
		23 kW	50	50	60	50	50	60	50	50	60	50	60
		34.5 kW	70	70	80	70	70	80	70	70	80	70	80
³ Minimum Circuit Ampacity	Unit+ ⁴ Electric Heat and 0.25 kW (0.33 HP)Power Exhaust	5.7 kW	22	23	27	22	23	27	22	23	27	22	23
		11.5 kW	26	28	32	26	28	32	26	28	32	26	28
		17.2 kW	36	38	42	36	38	42	36	38	42	36	38
		23 kW	46	48	52	46	48	52	46	48	52	46	48
		34.5 kW	66	68	72	66	68	72	66	68	72	66	68

¹ Extremes of operating range are plus and minus 10% of line voltage.

² Heating / Air Conditioning / Refrigeration (HACR) type breaker or fuse.

³ Refer to local codes to determine wire, fuse and disconnect size requirements.

⁴ Nominal kW based on 420V-3ph-50hz.

ELECTRICAL/ELECTRIC HEAT DATA

Model No.		KCB120S4			KCA120H4			KCB150S4		
¹ Voltage - 50hz 3 Phase with neutral		380/420V			380/420V			380/420V		
Compressor 1	Rated Load Amps	8			8			8		
	Locked Rotor Amps	59			59			67		
Compressor 2	Rated Load Amps	8			8			10.6		
	Locked Rotor Amps	59			59			74		
Outdoor Fan Motors (2)	Full Load Amps	1.3			1.3			1.5		
	(total)	(2.6)			(2.6)			(3.0)		
Power Exhaust (1) 0.25 kW (0.33 HP)	Full Load Amps	1.3			1.3			1.3		
Indoor Blower Motor	kW	1.5	2.2	3.7	1.5	2.2	3.7	1.5	2.2	3.7
	Full Load Amps	3.6	5.3	8.2	3.6	5.3	8.2	3.6	5.3	8.2
² Maximum Overcurrent Protection	Unit Only	30	30	35	30	30	35	35	40	40
	With 0.25 kW (0.33 HP) Power Exhaust	30	35	35	30	35	35	35	40	40
³ Minimum Circuit Ampacity	Unit Only	25	26	29	25	26	29	28	30	33
	With 0.25 kW (0.33 HP) Power Exhaust	26	28	31	26	28	31	30	31	34

ELECTRIC HEAT DATA

Electric Heat Voltage			420V	420V	420V	420V	420V	420V	420V	420V	420V
² Maximum Overcurrent Protection	Unit+ ⁴ Electric Heat	11.5 kW	30	30	35	30	30	35	30	30	35
		17.2 kW	35	40	40	35	40	40	35	40	40
		23 kW	45	50	50	45	50	50	45	50	50
		34.5 kW	70	70	70	70	70	70	70	70	70
		45.9 kW	70	70	80	70	70	80	70	70	80
³ Minimum Circuit Ampacity	Unit+ ⁴ Electric Heat	11.5 kW	25	27	30	25	27	30	25	27	30
		17.2 kW	35	37	40	35	37	40	35	37	40
		23 kW	44	47	50	44	47	50	44	47	50
		34.5 kW	64	66	70	64	66	70	64	66	70
		45.9 kW	68	70	74	68	70	74	68	70	74
² Maximum Overcurrent Protection	Unit+ ⁴ Electric Heat and 0.25 kW (0.33 HP) Power Exhaust	11.5 kW	30	35	35	30	35	35	30	35	35
		17.2 kW	40	40	45	40	40	45	40	40	45
		23 kW	50	50	60	50	50	60	50	50	60
		34.5 kW	70	70	80	70	70	80	70	70	80
		45.9 kW	70	80	80	70	80	80	70	80	80
³ Minimum Circuit Ampacity	Unit+ ⁴ Electric Heat and 0.25 kW (0.33 HP) Power Exhaust	11.5 kW	26	28	32	26	28	32	26	28	32
		17.2 kW	36	38	42	36	38	42	36	38	42
		23 kW	46	48	52	46	48	52	46	48	52
		34.5 kW	66	68	72	66	68	72	66	68	72
		45.9 kW	70	72	76	70	72	76	70	72	76

¹ Extremes of operating range are plus and minus 10% of line voltage.

² Heating / Air Conditioning / Refrigeration (HACR) type breaker or fuse.

³ Refer to local codes to determine wire, fuse and disconnect size requirements.

⁴ Nominal kW based on 420V-3ph-50hz.

ELECTRIC HEAT CAPACITIES

Volts Input	5.7 kW			11.5 kW			17.2 kW			23 kW			34.5 kW			45.9 kW		
	kW Input	Btuh Output	No. of Stages	kW Input	Btuh Output	No. of Stages	kW Input	Btuh Output	No. of Stages	kW Input	Btuh Output	No. of Stages	kW Input	Btuh Output	No. of Stages	kW Input	Btuh Output	No. of Stages
380	4.7	16 000	1	9.4	32 100	1	14.1	48 200	1	18.8	64 200	2	28.2	96 300	2	37.6	128 400	2
400	5.2	17 800	1	10.4	35 500	1	15.6	53 300	1	20.9	71 400	2	31.2	106 600	2	41.6	142 100	2
420	5.7	19 500	1	11.5	39 300	1	17.2	58 700	1	23	78 500	2	34.5	117 500	2	45.9	156 800	2

UNIT CLEARANCES

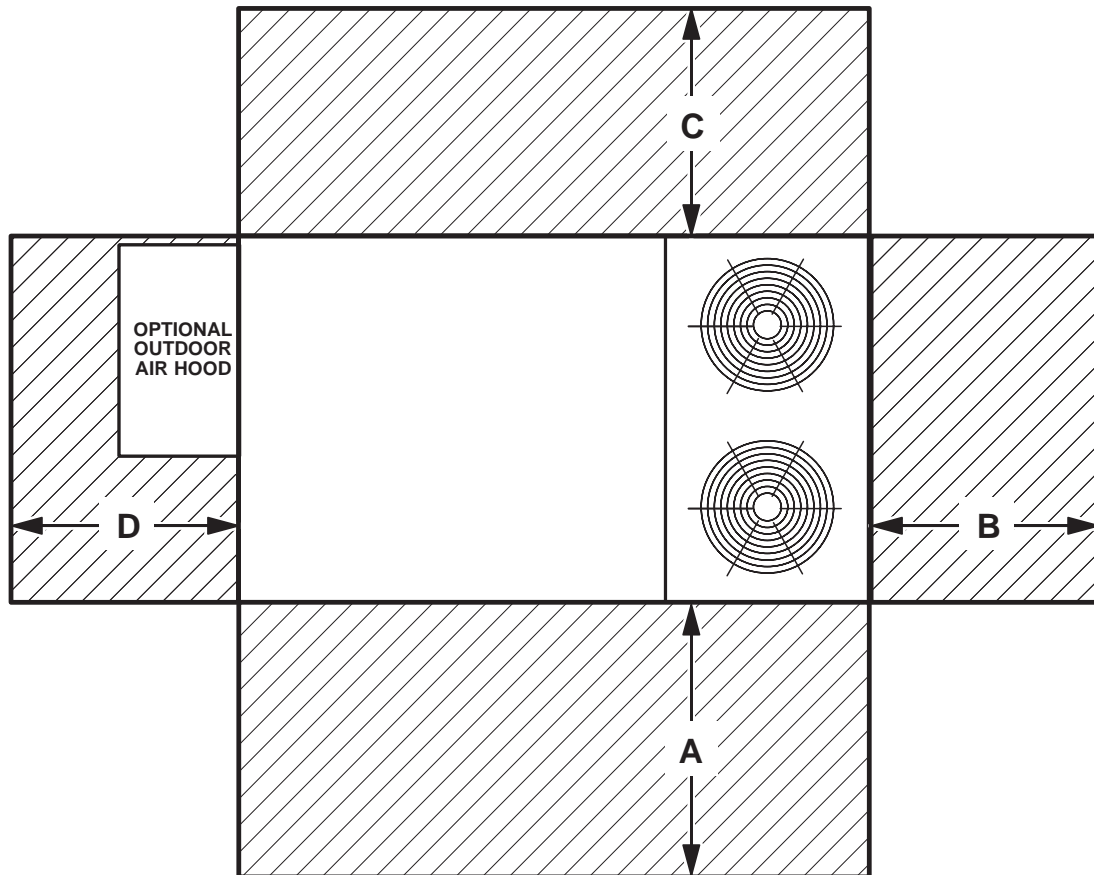

¹ Unit Clearance	A		B		C		D		Top Clearance
	mm	in.	mm	in.	mm	in.	mm	in.	
Service Clearance	1524	60	914	36	914	36	1524	60	Unobstructed
Minimum Operation Clearance	914	36	914	36	914	36	914	36	

NOTE - Entire perimeter of unit base requires support when elevated above the mounting surface.

¹ **Service Clearance** - Required for removal of serviceable parts.

Minimum Operation Clearance - Required clearance for proper unit operation.

OUTDOOR SOUND DATA

Unit Model Number	Octave Band Sound Power Levels dBA, re 10 ⁻¹² Watts - Center Frequency - Hz							¹ Sound Rating Number (dBA)
	125	250	500	1000	2000	4000	8000	
092, 102 and 120	76	79	84	83	79	73	66	88
150	75	81	87	85	80	73	67	90

Note - The octave sound power data does not include tonal corrections.

¹ Sound Rating Number according to AHRI Standard 270-95 or AHRI Standard 370-2001 (includes pure tone penalty). Sound Rating Number is the overall A-Weighted Sound Power Level, (LWA), dBA (100 Hz to 10,000 Hz).

WEIGHT DATA

Model Number	Outdoor Coil	Net		Shipping		Outdoor Coil	Net		Shipping	
		kg	lbs.	kg	lbs.		kg	lbs.	kg	lbs.
092H Base Unit	Environ™	477	1052	516	1137	---	---	---	---	---
092H Max. Unit	Environ™	548	1209	587	1294	---	---	---	---	---
102H Base Unit	Environ™	480	1059	519	1144	---	---	---	---	---
102H Max. Unit	Environ™	552	1216	590	1301	---	---	---	---	---
120H Base Unit	Environ™	496	1094	535	1179	---	---	---	---	---
120H Max. Unit	Environ™	571	1258	609	1343	---	---	---	---	---
092S Base Unit	Environ™	395	870	433	955	Fin/Tube	421	927	459	1012
092S Max. Unit	Environ™	466	1027	504	1112	Fin/Tube	492	1084	531	1169
102S Base Unit	Environ™	404	890	442	975	Fin/Tube	430	947	469	1032
102S Max. Unit	Environ™	475	1047	513	1132	Fin/Tube	501	1104	540	1189
120S Base Unit	Environ™	432	954	471	1039	Fin/Tube	465	1025	504	1110
120S Max. Unit	Environ™	507	1118	545	1203	Fin/Tube	540	1189	578	1274
150S Base Unit	---	---	---	---	---	Fin/Tube	492	1084	531	1169
150S Max. Unit	---	---	---	---	---	Fin/Tube	560	1234	599	1319

NOTE - Max. Unit is the unit with ALL INTERNAL OPTIONS Installed. (Economizer, Standard Static Power Exhaust Fans, Controls, etc.). Does not include accessories EXTERNAL to unit.

OPTIONS / ACCESSORIES

Model Number	Shipping Weight		
	kg	lbs.	
ECONOMIZER / OUTDOOR AIR / EXHAUST			
Economizer			
Economizer Dampers	27	60	
Barometric Relief Dampers (downflow)	4	8	
Barometric Relief Damper Hood (downflow)	11	25	
Outdoor Air Hood (downflow)	10	23	
Outdoor Air Dampers			
Outdoor Air Damper Section (downflow) - Automatic	4	9	
Outdoor Air Damper Section (downflow) - Manual	1	2	
Outdoor Air Damper Hood (downflow)	4	9	
Power Exhaust	14	31	
ELECTRIC HEAT			
5.7 kW	23	50	
11.5 kW	23	50	
17.2 kW	26	57	
23 kW	26	57	
34.5 kW	27	59	
45.9 kW	31	68	
MSAV (MULTI-STAGE AIR VOLUME) SUPPLY AIR BLOWER OPTION			
Variable Frequency Drive (VFD) and associated components	5	10	
ROOF CURBS			
Hybrid Roof Curbs, Downflow			
203 mm height	27	60	
356 mm height	39	85	
457 mm height	45	100	
610 mm height	57	125	
Adjustable Pitch Curb, Downflow			
356 mm height	82	191	
CEILING DIFFUSERS			
Step-Down	RTD11-95S	54	118
	RTD11-135S	61	135
	RTD11-185S	76	168
Flush	FD11-95S	54	118
	FD11-135S	61	135
	FD11-185S	76	168
Transitions	C1DIFF30B-1	14	30
	C1DIFF31B-1	15	32
	C1DIFF32B-1	16	36

PACKAGING

LTL Packaging (less than truck load)	48	105
--------------------------------------	----	-----

DIMENSIONS - UNIT

Model No.	CORNER WEIGHTS												CENTER OF GRAVITY											
	AA				BB				CC				DD				EE				FF			
	Base		Max.		Base		Max.		Base		Max.		Base		Max.		Base		Max.		Base		Max.	
	kg	lbs.	kg	lbs.	kg	lbs.	kg	lbs.	kg	lbs.	kg	lbs.	kg	lbs.	kg	lbs.	mm	in.	mm	in.	mm	in.	mm	in.
092H	122	270	141	310	104	230	120	265	113	249	130	287	137	302	158	348	1130	44-1/2	1105	43-1/2	622	24-1/2	648	25-1/2
102H	123	272	141	312	105	232	121	266	114	251	131	288	138	304	159	350	1130	44-1/2	1105	43-1/2	622	24-1/2	648	25-1/2
120H	128	283	148	325	108	238	124	274	116	257	134	295	143	316	165	363	1118	44	1092	43	629	24-3/4	654	25-3/4
092S	101	223	141	309	86	190	118	259	94	206	124	275	113	250	154	341	1130	44-1/2	1105	43-1/2	622	24-1/2	648	25-1/2
102S	104	228	143	316	88	195	119	262	96	211	127	280	116	254	157	347	1130	44-1/2	1105	43-1/2	622	24-1/2	648	25-1/2
120S	110	243	150	331	93	204	124	273	100	220	133	294	123	271	167	369	1118	44	1092	43	629	24-3/4	654	25-3/4
150S	119	263	138	305	101	222	117	257	110	242	127	280	135	298	157	346	1118	44	1092	43	610	24	635	25

Base Unit - The unit with NO OPTIONS.

Max. Unit - The unit with ALL OPTIONS Installed. (Economizer, etc.)

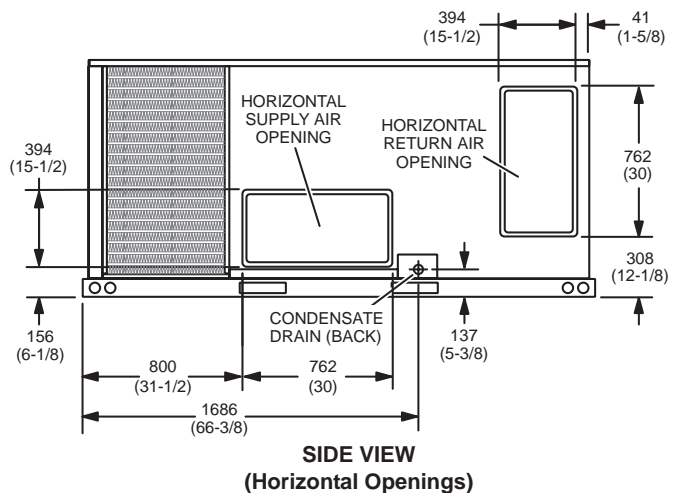
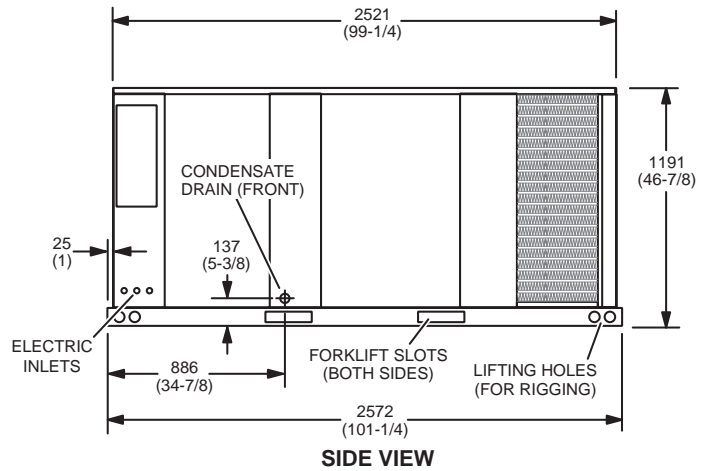
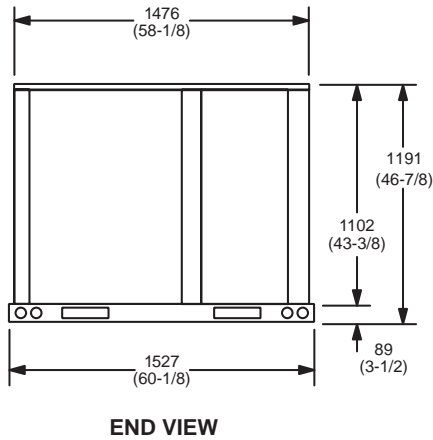
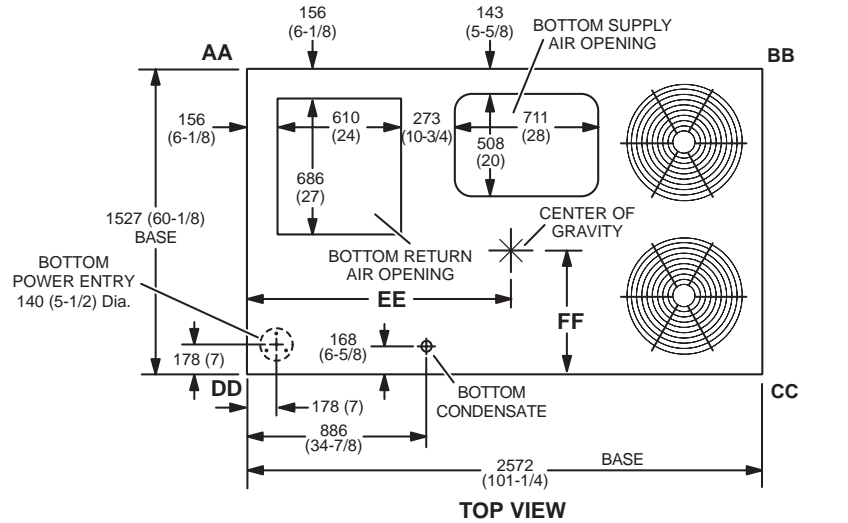

OUTDOOR AIR HOOD DETAIL

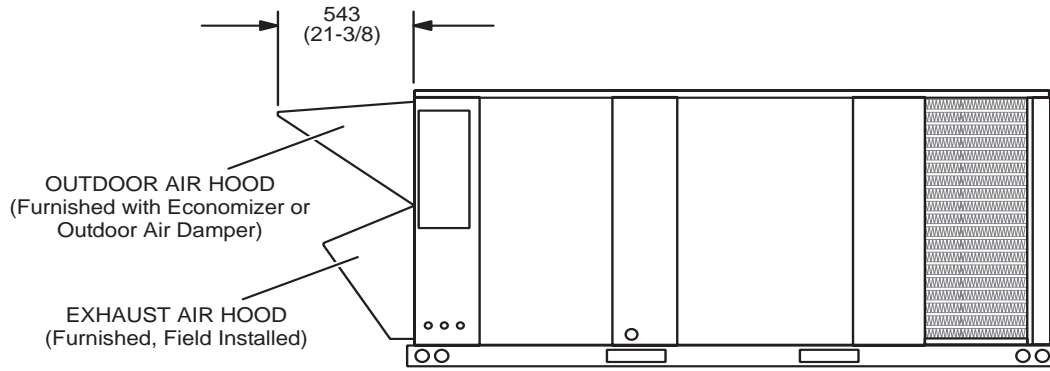

DIMENSIONS - ACCESSORIES

HORIZONTAL ECONOMIZER APPLICATION

(With Furnished Barometric Relief Dampers and Optional Horizontal Discharge Kit - Required)

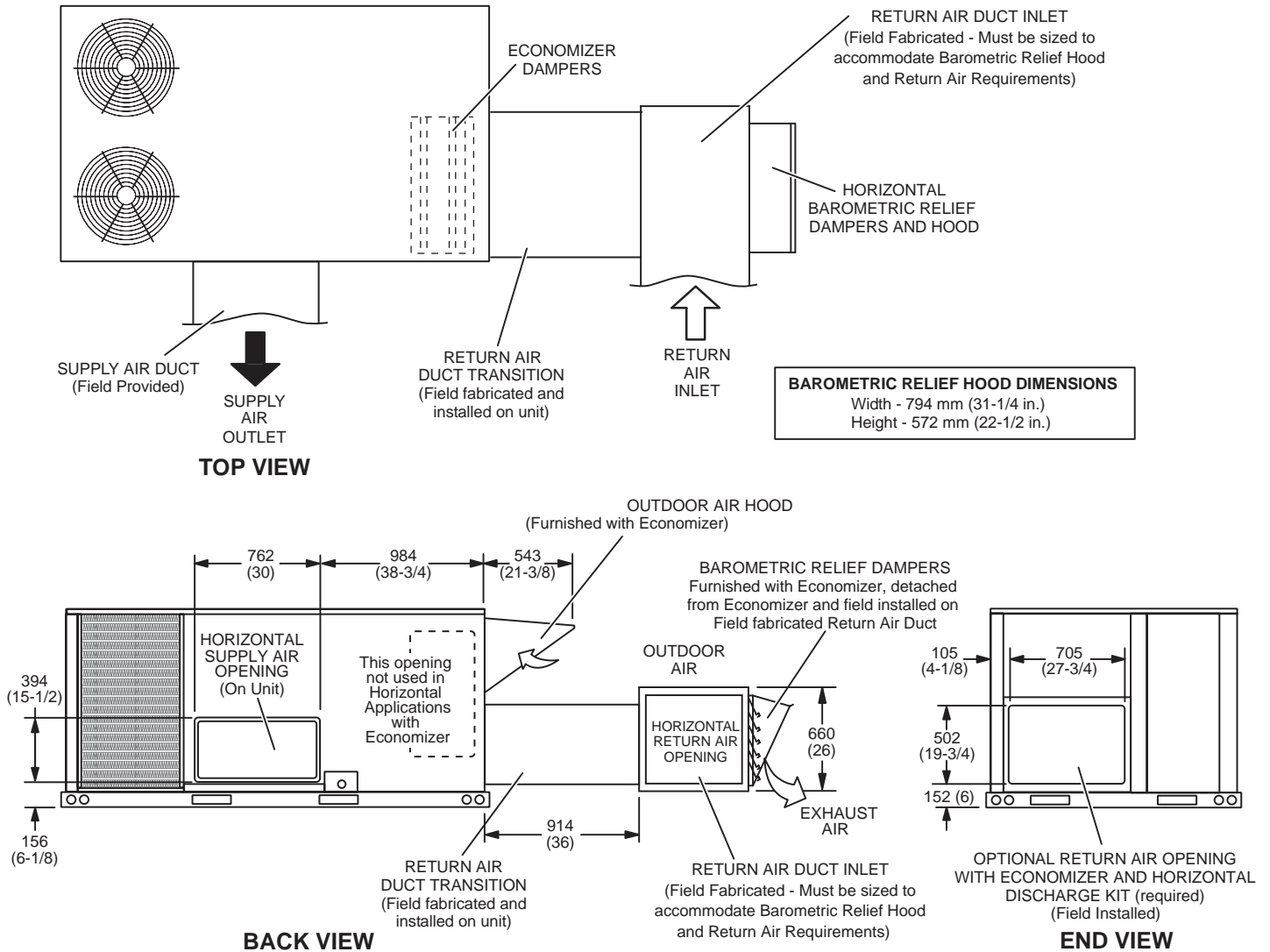

NOTE - Return Air Duct and Transition must be supported.

BAROMETRIC RELIEF DAMPERS (Furnished with Economizer)

(Field installed in horizontal return air duct adjacent to unit)

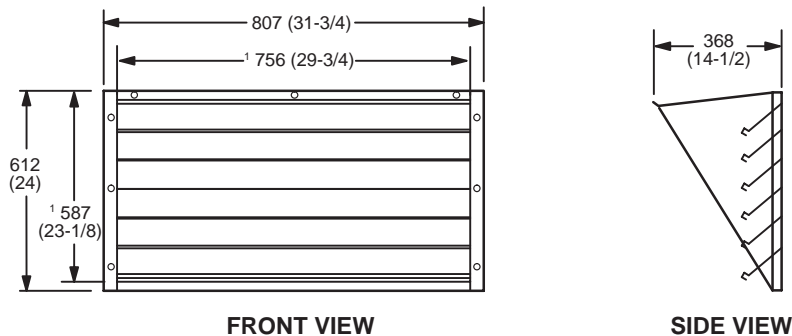

¹ NOTE - Opening size required in return air duct.

DIMENSIONS - ACCESSORIES

HORIZONTAL ECONOMIZER APPLICATION

(with Optional Low Profile Horizontal Barometric Relief Dampers and Horizontal Discharge Kit - Required)

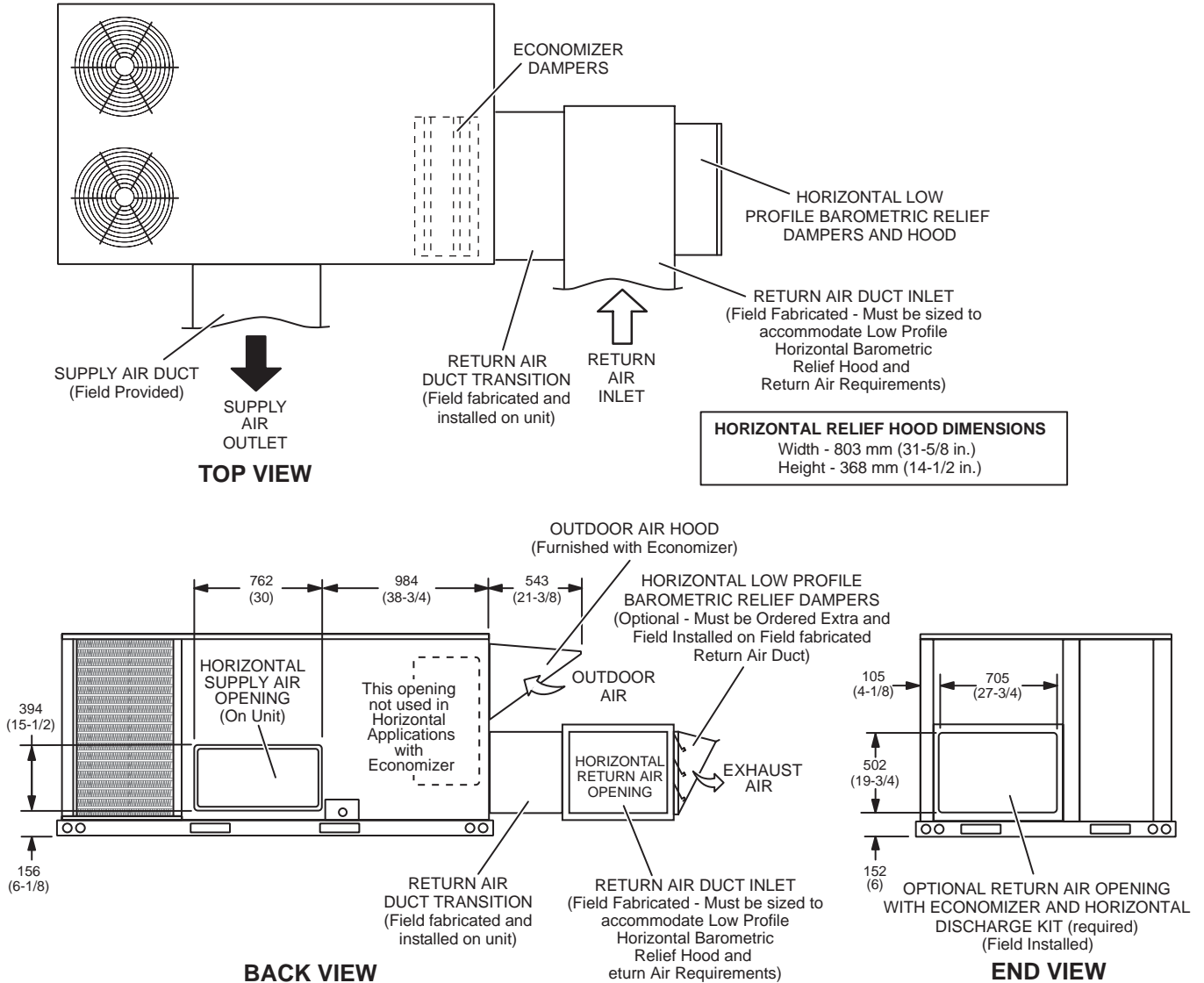

NOTE - Return Air Duct and Transition must be supported.

HORIZONTAL LOW PROFILE BAROMETRIC RELIEF DAMPERS

(Field installed in horizontal return air duct adjacent to unit)

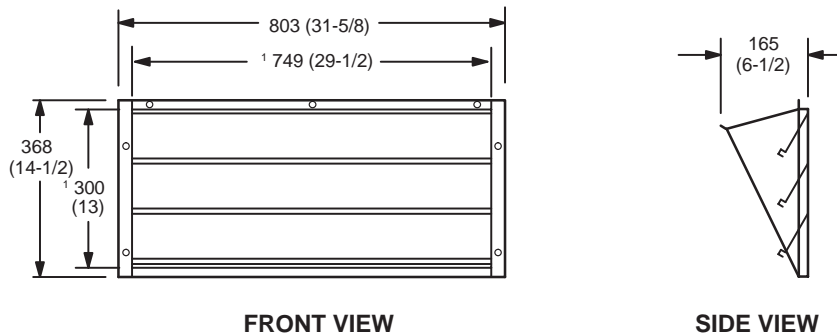

¹ NOTE - Opening size required in return air duct.

DIMENSIONS - ACCESSORIES

HYBRID ROOF CURBS - DOUBLE DUCT OPENING

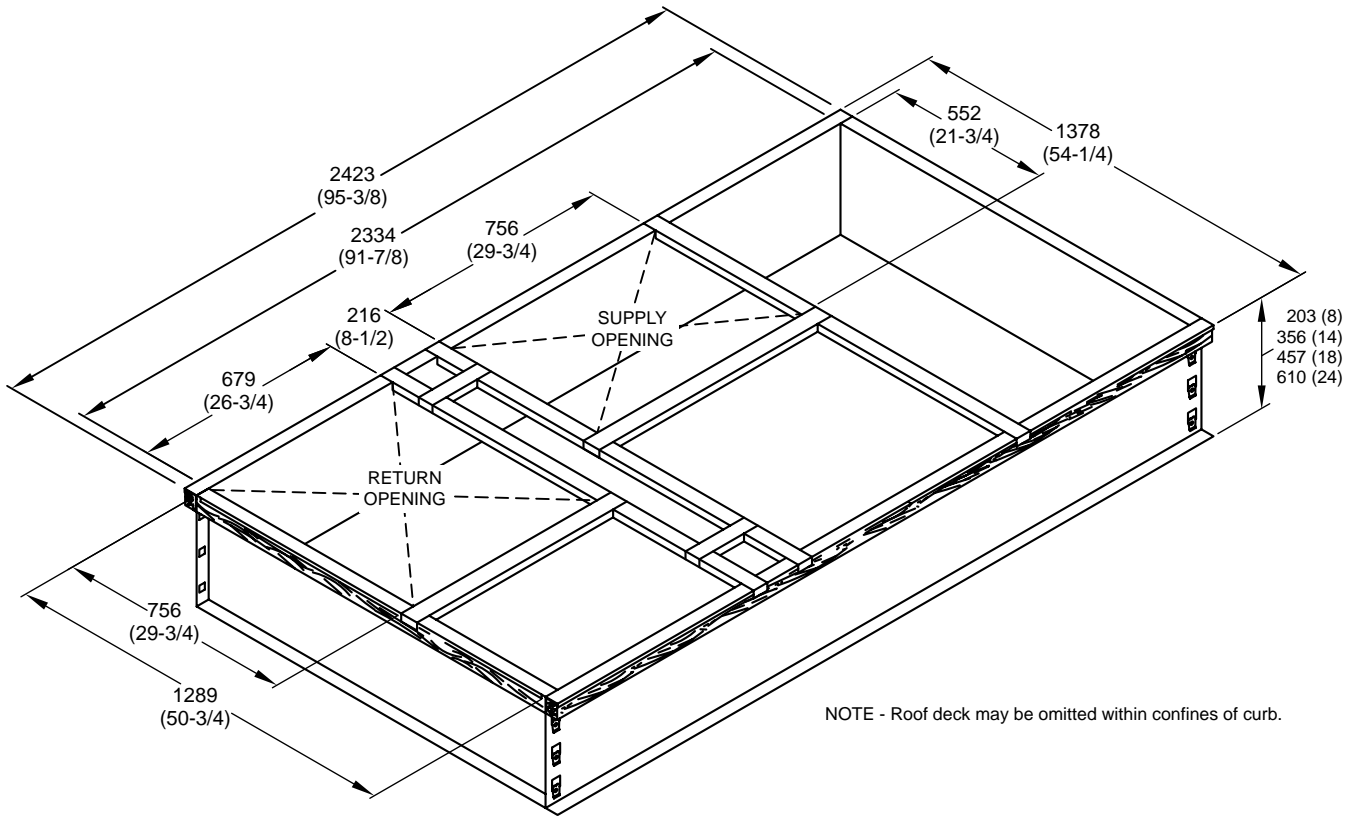

TYPICAL FLASHING DETAIL FOR ROOF CURB

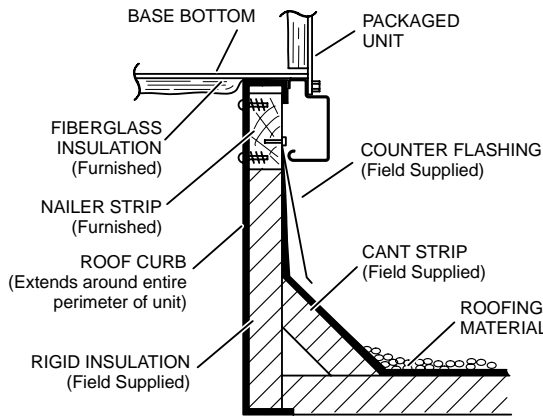

DETAIL ROOF CURB

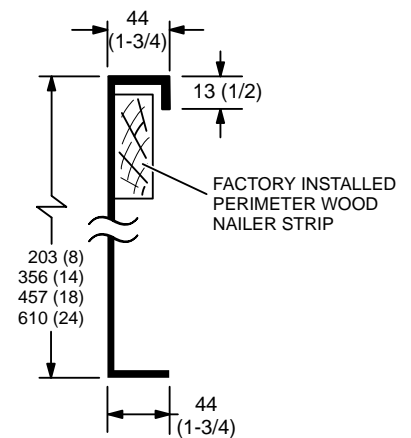

DIMENSIONS - ACCESSORIES

ADJUSTABLE PITCH CURBS - DOUBLE DUCT OPENING

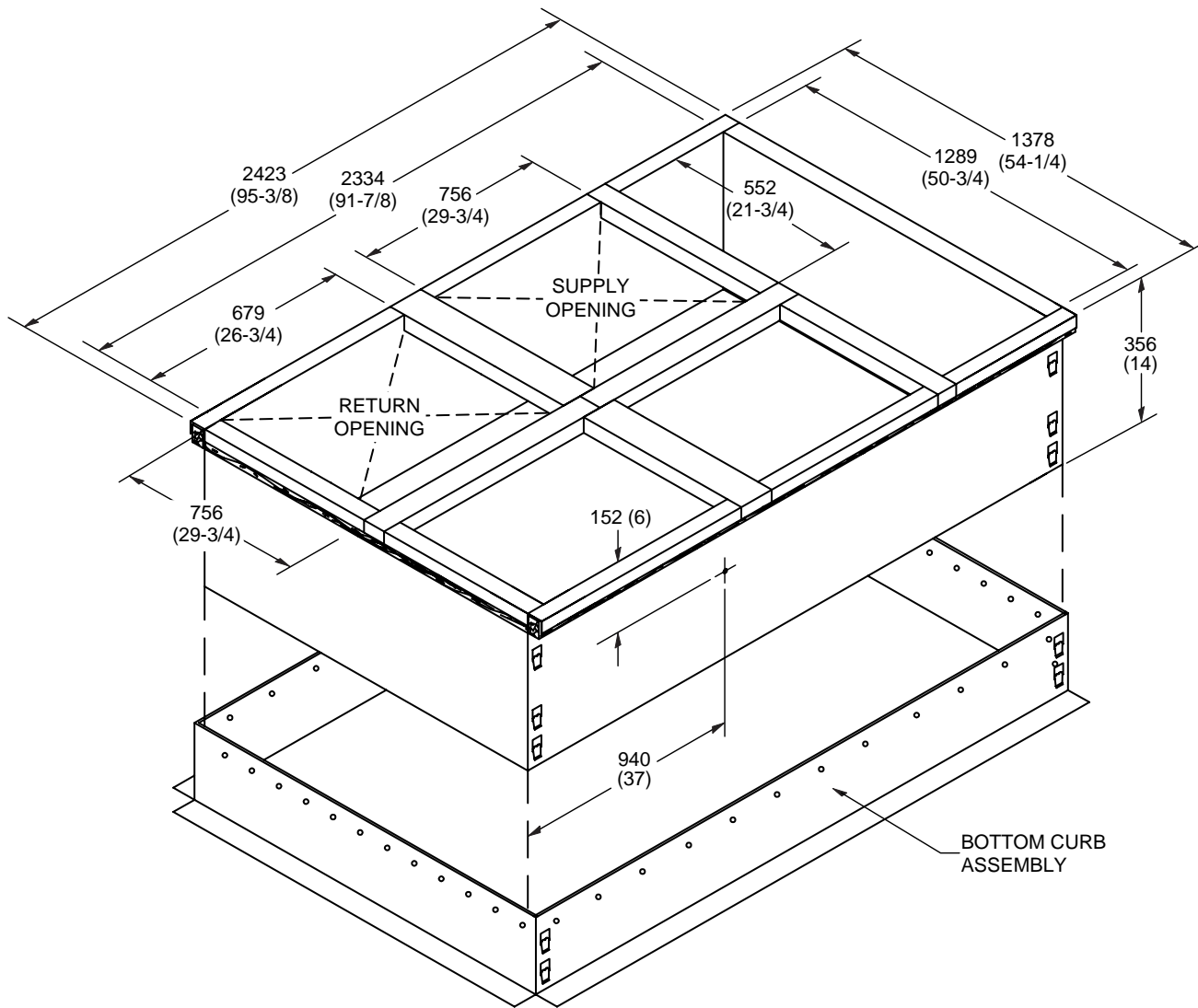

NOTE - Maximum slope pitch is 19 mm per 305 mm (3/4 in. per 1 foot) in any one direction.

TYPICAL FLASHING DETAIL FOR ROOF CURB

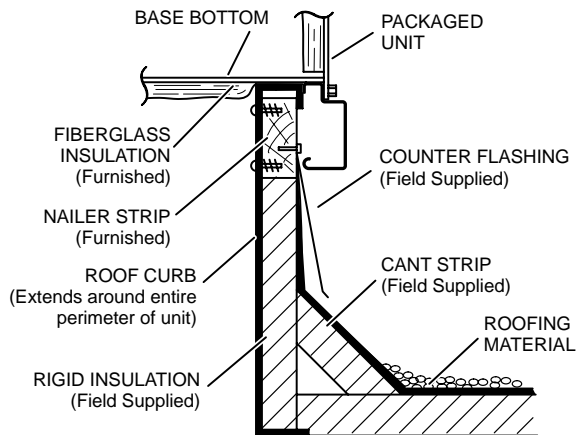

DETAIL ROOF CURB

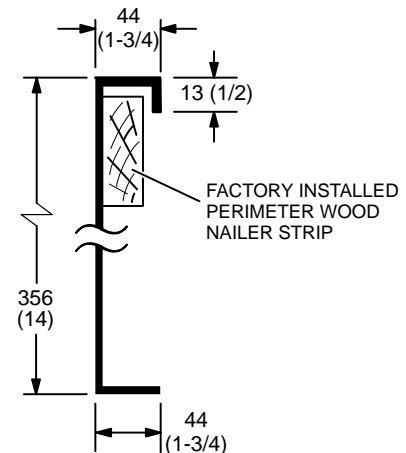

DIMENSIONS - ACCESSORIES

ROOF CURBS WITH SUPPLY & RETURN AIR TRANSITIONS FOR CEILING DIFFUSERS

C1DIFF30B-1 ROUND TRANSITIONS
(for 092 models)

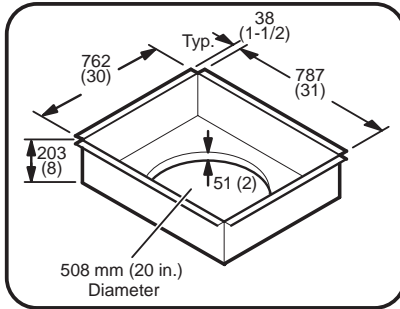

C1DIFF31B-1 & C1DIFF32B-1 RECTANGULAR TRANSITIONS
(for 102 thru 150 models)

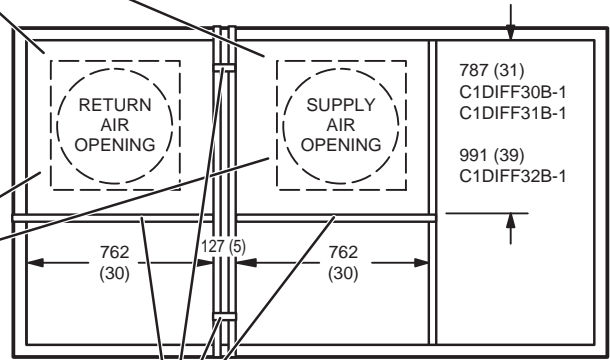
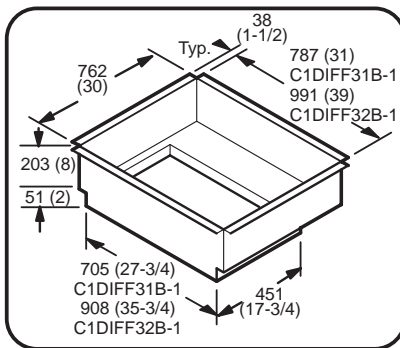

TOP VIEW

NOTE - These four supports are furnished with the transitions to replace supports furnished with curb for proper transition spacing.

DIMENSIONS - ACCESSORIES

COMBINATION CEILING SUPPLY AND RETURN DIFFUSERS

STEP-DOWN CEILING DIFFUSER

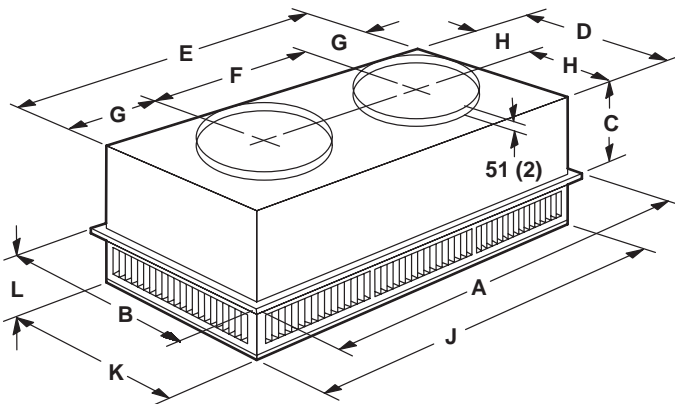

FLUSH CEILING DIFFUSER

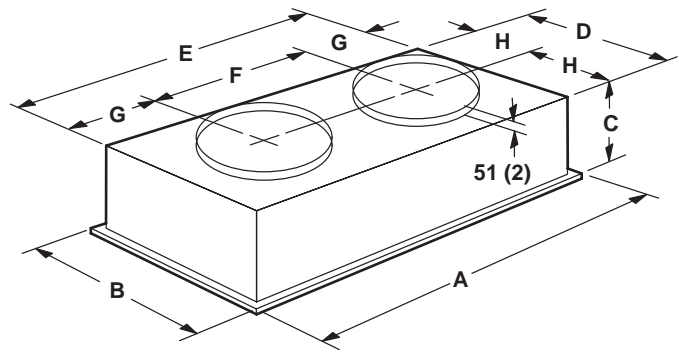

Model Number		RTD11-95S
A	mm	1159
	in.	47-5/8
B	mm	752
	in.	29-5/8
C	mm	365
	in.	14-3/8
D	mm	699
	in.	27-1/2
E	mm	1158
	in.	45-1/2
F	mm	572
	in.	22-1/2
G	mm	292
	in.	11-1/2
H	mm	349
	in.	13-3/4
J	mm	1156
	in.	45-1/2
K	mm	699
	in.	27-1/2
L	mm	206
	in.	8-1/8
Duct Size	mm	508 round
	in.	20 round

Model Number		FD11-95S
A	mm	1159
	in.	47-5/8
B	mm	752
	in.	29-5/8
C	mm	422
	in.	16-5/8
D	mm	686
	in.	27
E	mm	1143
	in.	45
F	mm	22-1/2
	in.	572
G	mm	286
	in.	11-1/4
H	mm	343
	in.	13-1/2
Duct Size	mm	508 round
	in.	20 round

DIMENSIONS - ACCESSORIES

COMBINATION CEILING SUPPLY AND RETURN DIFFUSERS

STEP-DOWN CEILING DIFFUSER

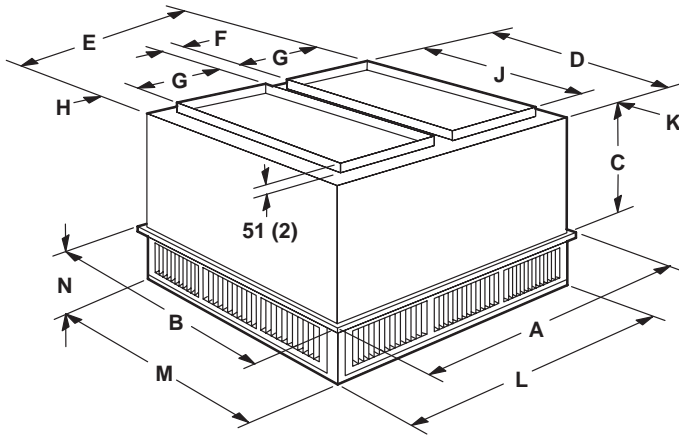

FLUSH CEILING DIFFUSER

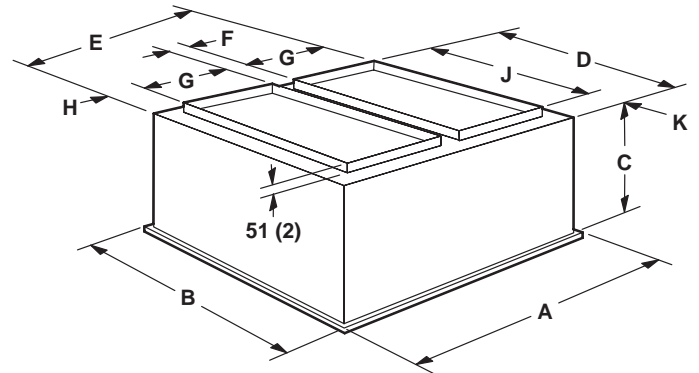

Model Number		RTD11-135S	RTD11-185S
A	mm	1210	1210
	in.	47-5/8	47-5/8
B	mm	905	1210
	in.	35-5/8	47-5/8
C	mm	524	625
	in.	20-5/8	24-5/8
D	mm	851	1156
	in.	33-1/2	45-1/2
E	mm	1156	1156
	in.	45-1/2	45-1/2
F	mm	114	114
	in.	4-1/2	4-1/2
G	mm	457	457
	in.	18	18
H	mm	64	64
	in.	2-1/2	2-1/2
J	mm	711	914
	in.	28	36
K	mm	70	121
	in.	2-3/4	4-3/4
L	mm	1156	1156
	in.	45-1/2	45-1/2
M	mm	851	1156
	in.	33-1/2	45-1/2
N	mm	232	257
	in.	9-1/8	10-1/8
Duct Size	mm	457 x 711	457 x 914
	in.	18 x 28	18 x 36

Model Number		FD11-135S	FD11-185S
A	mm	1210	1210
	in.	47-5/8	47-5/8
B	mm	905	1210
	in.	35-5/8	47-5/8
C	mm	591	743
	in.	23-1/4	29-1/4
D	mm	838	1143
	in.	33	45
E	mm	1143	1143
	in.	45	45
F	mm	112	112
	in.	4-1/2	4-1/2
G	mm	457	457
	in.	18	18
H	mm	57	57
	in.	2-1/4	2-1/4
J	mm	711	914
	in.	28	36
K	mm	64	114
	in.	2-1/2	4-1/2
Duct Size	mm	457 x 711	457 x 914
	in.	18 x 28	18 x 36

REVISIONS

Section	Description
Optional Conventional Temperature Control Systems	Added BACnet controls.



Visit us at www.lennox.com

For the latest technical information, www.lennoxcommercial.com

Contact us at 1-800-4-LENNOX

NOTE - Due to Lennox' ongoing commitment to quality, Specifications, Ratings and Dimensions subject to change without notice and without incurring liability. Improper installation, adjustment, alteration, service or maintenance can cause property damage or personal injury. Installation and service must be performed by a qualified installer and servicing agency.

©2020 Lennox Industries, Inc.