



PACKAGED GAS ELECTRIC

KGA/KGB

Landmark® Rooftop Units

50 Hz

**COMMERCIAL
PRODUCT SPECIFICATIONS**

Bulletin No. 490145
March 2021
Supersedes August 2019



LANDMARK®
Performance Marked by Flexibility™



45.7 to 88 kW (13 to 25 Ton)
Net Cooling Capacity - 37.1 to 68.6 kW (127 000 to 234 000 Btuh)
Gas Input Heat Capacity - 49.5 to 123.0 kW (169 000 to 420 000 Btuh)

MODEL NUMBER IDENTIFICATION

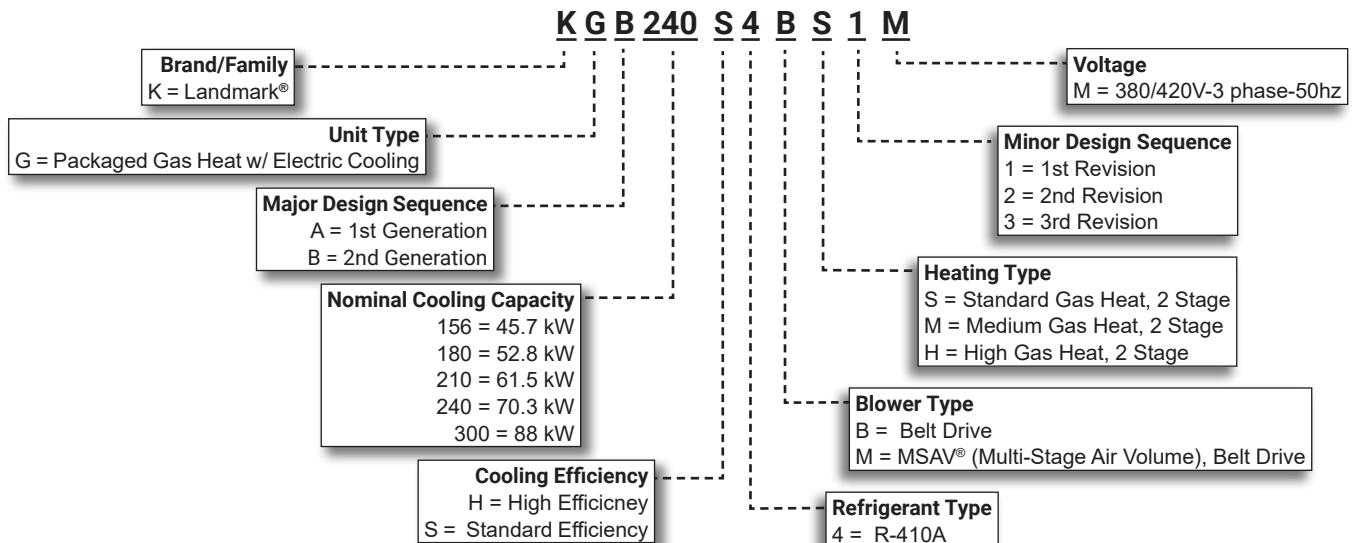

FEATURE HIGHLIGHTS

Landmark® rooftop units from Lennox are the new standard for reliable, efficient rooftop units built for long-lasting performance that can significantly improve indoor and outdoor environments.

1. Aluminized Steel Inshot Burners
2. Scroll Compressors
3. Filter/Driers
4. Coil System
5. Outdoor Coil Fan Motors
6. Construction
7. Blower
8. Unit Control
9. Air Filters
10. Economizer
11. Downflow Barometric Relief Dampers with Exhaust Hood
12. Power Exhaust Fan

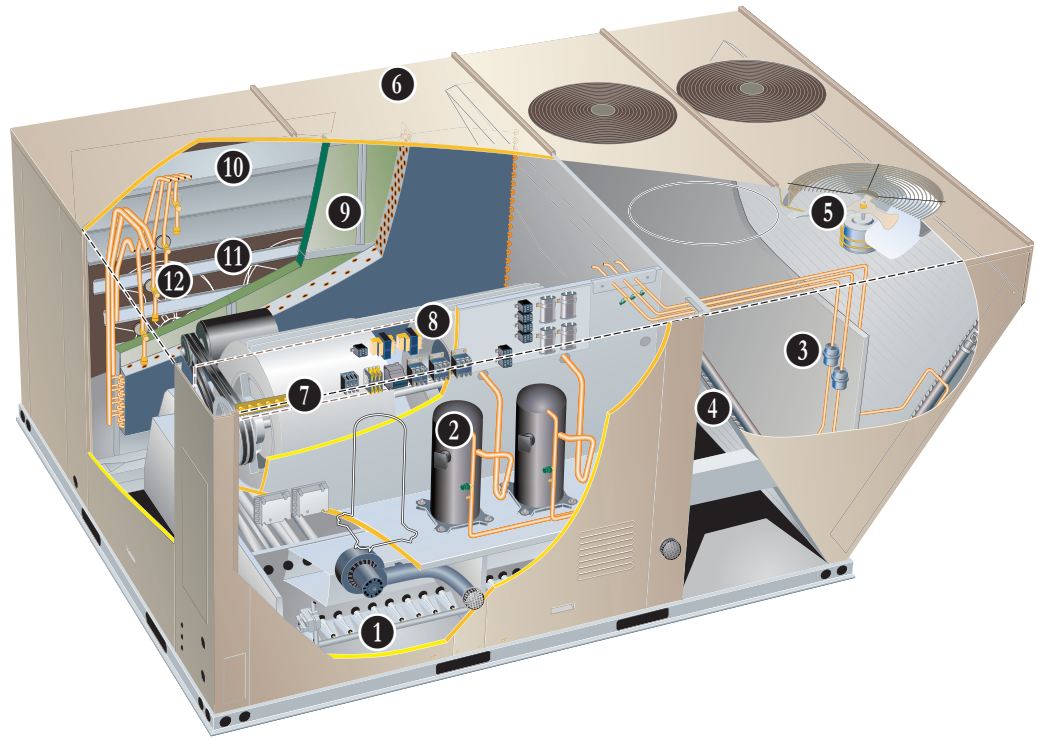

CONTENTS

Approvals	3
Blower Data	31
Dimensions - Accessories	41
Dimensions - Unit	38
Electrical Data - High Efficiency	35
Electrical Data - Standard Efficiency	35
Features And Benefits	3
High Altitude Derate	18
Model Number Identification.	1
Optional Conventional Temperature Control Systems	10
Options / Accessories - Standard And High Efficiency Models.	11
Outdoor Sound Data	36
Ratings - High Efficiency	27
Ratings - Standard Efficiency	19
Specifications - Gas Heat	18
Specifications - High Efficiency Models	17
Specifications - Standard Efficiency Models	15
Unit Clearances	36
Weight Data	37

APPROVALS

PERFORMANCE/QUALITY

- Components bonded for grounding to meet safety standards for servicing required by Underwriters Laboratories (UL) and the International Electrotechnical Commission (IEC)
- Cooling performance is rated at test conditions included in Air-Conditioning, Heating and Refrigeration (AHRI) Standard 340/360 while operating at rated voltage and air volumes
- International Organization for Standardization (ISO) 9001 Registered Manufacturing Quality System

FEATURES AND BENEFITS

HEATING SYSTEM

- ① • Aluminized steel inshot burners
- Direct spark ignition
- Electronic flame sensor
- Combustion air inducer
- Redundant automatic dual stage gas valve with manual shut-off

Heat Exchanger

- Tubular construction
- Aluminized steel
- Life cycle tested

NOTE - Optional Stainless Steel Heat Exchanger is required if mixed air temperature is below 7°C

Electronic Pilot Ignition

- Provides positive direct ignition of burners on each operating cycle
- System permits main gas valve to stay open only when the burners are proven to be lit
- Should a loss of flame occur, the gas valve closes, shutting off the gas to the burners
- LED indicates status and aid in troubleshooting
- Factory installed in the controls section

Limit Controls

- Factory installed
- Redundant limit controls with fixed temperature setting
Protects heat exchanger and other components from overheating

Safety Switches

- Protects system operation
- Flame roll-out switch
- Flame sensor
- Combustion air inducer proving switch

Required Selections

Gas Input Choice - Order one:

- Standard Gas Heat, 2 Stage (49.5/76.1 kW)
- Medium Gas Heat, 2 Stage (68.5/105.4 kW)
- High Gas Heat, 2 Stage (91.4/140.5 kW)

Options / Accessories

Factory Installed

Stainless Steel Heat Exchanger

- Required if mixed air temperature is below 7°C

Field Installed

Bottom Gas Piping Kit

- Allows bottom gas entry

Combustion Air Intake Extensions

- Recommended for use with existing flue extension kits in areas where high snow areas can block intake air
- Order two kits

LPG/Propane Kits

- Conversion kit to field change over units from Natural Gas to LPG/Propane
- Order two kits

Vertical Vent Extension Kit

- Use to exhaust flue gases vertically above unit
- Required when unit vent is too close to fresh air intakes per building codes
- Also prevents ice formation on intake louvers
- Contains vent transition, vent tee, drain cap and installation hardware

NOTE - Straight vent pipes (102 mm B-Vent) and caps are not furnished and must be field supplied. Refer to kit instructions for additional information.

FEATURES AND BENEFITS

COOLING SYSTEM

- Designed to maximize sensible and latent cooling performance at design conditions
- System can operate from -1°C to 52°C without any additional controls

R-410A Refrigerant

- Non-chlorine based
- Ozone-friendly

2 Scroll Compressors

- Scroll compressors on all models for high performance, reliability and quiet operation
- Resiliently mounted on rubber grommets for quiet operation

Compressor Crankcase Heaters

Protect against refrigerant migration that can occur during low ambient operation

Thermal Expansion Valves

(All High Efficiency Models, 300S Model)

- Assures optimal performance throughout the application range
- Removable element head

Refrigerant Metering Orifice

(All Standard Efficiency Models except 300S Model)

- Accurately meters refrigerant in system
- Refrigerant control is accomplished by exact sizing of refrigerant metering orifice

3 Filter/Driers

- High capacity filter/drier protects the system from dirt and moisture

High Pressure Switches

- Protects the compressor from overload conditions such as dirty condenser coils, blocked refrigerant flow, or loss of outdoor fan operation

Freezestats

- Protects the evaporator coil from damaging ice build-up due to conditions such as low/no airflow, or low refrigerant charge

4 Lennox' Environ™ Coil System

Lightweight, all aluminum brazed fin construction

- Constructed of three components
 - A flat extrusion tube
 - Fins in-between the flat extrusion tube
 - Two refrigerant manifolds

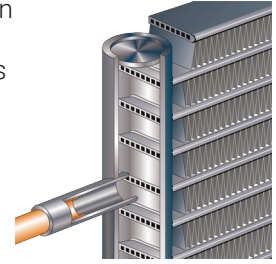

Environ™ Coil System Features:

- Improved heat transfer performance due to high primary surface area (flat tubes) versus secondary surface (fins)
- Smaller internal volume (reduced refrigerant charge)
- High durability
- All aluminum construction
- Fewer brazed joints
- Compact design
- Reduced unit weight
- Easy maintenance/cleaning
- Face split design
- Mounting brackets with rubber inserts
- Angled cabinet design protects coil from damage

Evaporator Coil

- Copper tube construction
- Enhanced rippled-edge aluminum fins
- Flared shoulder tubing connections
- Silver soldered construction
- Factory leak tested
- Cross row circuiting with rifled tubing

Condensate Drain Pan

- Plastic, sloped drain pan
- Side or bottom drain connections

5 Outdoor Coil Fan Motors

- Thermal overload protected
- Totally enclosed
- Permanently lubricated ball bearings
- Shaft up
- Wire basket mount

Outdoor Coil Fans

- Polyvinyl chloride (PVC) coated fan guard furnished

Required Selections

Cooling Capacity

- Specify nominal cooling capacity

FEATURES AND BENEFITS

COOLING SYSTEM (continued)

Options / Accessories

Factory Installed

Conventional Fin/Tube Condenser Coil (replaces Environ™ Coil System, Standard Efficiency Models only)

- Copper tube construction
- Enhanced rippled-edge aluminum fins
- Flared shoulder tubing connections
- Silver soldered construction

Field Installed

Condensate Drain Trap

- Available in copper or polyvinyl chloride (PVC)

Drain Pan Overflow Switch

- Monitors condensate level in drain pan, shuts down unit if drain becomes clogged

Low Ambient Controls

- Units operate satisfactorily down to 7°C outdoor air temperature without any additional controls
- Two low ambient control options are available for field installation
 1. **Low Ambient Control Kit (-1°C)** - Allows unit operation down to -1°C
 2. **Low Ambient Control Kit (-17°C)** - Allows unit operation down to -17°C without evaporator coil icing
 - Head pressure speed control reduces outdoor fan operation during low ambient conditions until head pressure rises to the setpoint
 - Pressure transducers are mounted on the liquid lines
 - High pressure switches are furnished to replace existing
 - Wiring harnesses are furnished for simple plug-in wiring to fans and controller

CABINET

6 Construction

- Heavy-gauge steel panels
- Full perimeter heavy-gauge galvanized steel base rail
- Base rails have rigging holes
- Three sides of the base rail have forklift slots
- Raised edges around duct and power entry openings in the bottom of the unit for water protection

Airflow Choice

- Units are shipped in downflow (vertical) return air flow configuration

NOTE - Units can be field converted to horizontal air flow with optional Horizontal Return Air Panel Kit and Horizontal Roof Curb.

Power/Gas Entry

- Electrical and gas lines can be brought through the unit base or through horizontal access knock-outs

Exterior Panels

- Constructed of heavy-gauge, galvanized steel
- Two-layer enamel paint finish

Insulation

- Fully insulated with non-hygroscopic fiberglass insulation (conditioned areas)
- Unit base is fully insulated
- Base insulation serves as an air seal to the roof curb, eliminating the need to add a seal during installation

Access Panels

- Economizer/Filter section
- Heating/Blower section
- Compressor/Controls section

Options / Accessories

Factory Installed

Corrosion Protection

- Completely flexible immersed coating
- Electrodeposited dry film process
- AST ElectroFin E-Coat
- Meets Mil Spec MIL-P-53084, ASTM B117 Standard Method Salt Spray Testing
- Indoor Corrosion Protection:
 - Coated coil
 - Painted blower housing
 - Painted indoor base
- Outdoor Corrosion Protection:
 - Coated coil
 - Painted outdoor base

Hinged Access Panels

- Filter section
- Heating/Blower section
- Compressor/Controls section.
- Panel seals and quarter-turn latching handles provide a tight air and water seal

Field Installed

Combination Coil/Hail Guards

- Heavy gauge steel frame
- Painted to match cabinet
- Expanded metal mesh protects outdoor coil

Horizontal Return Air Panel Kit

- Required for horizontal applications with Horizontal Roof Curb
- Contains panel with return air opening for field replacement of existing unit panel and panel to cover bottom return air opening in unit
- See dimension drawings

FEATURES AND BENEFITS

BLOWER

- 7 A wide selection of supply air blower options are available to meet a variety of airflow requirements

Motor

- Overload protected, equipped with ball bearings
- Belt drive motors are offered on all models and are available in several different sizes to maximize air performance

Supply Air Blower

- Forward curved blades
- Double inlet
- Blower wheel statically and dynamically balanced
- Ball bearings
- Adjustable pulley (allows speed change)
- Blower assembly slides out of unit for servicing

Required Selections

- Order blower motor output and drive kit number required when base unit is ordered
- See Drive Kit Specifications Table

Select Constant Air Volume (CAV) or MSAV® (Multi-Stage Air Volume) Supply Air Blower Option

- Constant Air volume (CAV) models supply a constant volume of air
- MSAV® (Multi-Stage Air Volume) supply air blower option models utilize a Variable Frequency Drive (VFD) to stage the supply air blower airflow
 - The VFD alters the frequency and voltage of the power supply to the blower to control blower speed
 - The supply air blower has two speeds:
 1. Low speed for part-load cooling operation.

NOTE - Low speed is 66% of high speed.

2. High speed for full load cooling and all heat modes.

- Full speed blower operation is set by adjusting the motor pulley to deliver the desired air volume.
- The ventilation speed is selectable between high and low speed.

NOTE - Part load airflow in cooling mode on MSAV® models should not be set below 30 L/s per kW to reduce the risk of evaporator coil freeze-up.

- The VFD has an operational range of -40 to 52°C outdoor air ambient temperature
- Lower operating costs are obtained when the blower is operated on lower speeds

MSAV® Sequence of Operation

- Ventilation speed is determined by the VENT SPEED switch setting on VFD control board (LO or HI)
- Blower operates in low speed for mechanical cooling (Y1)
- Blower operates in high speed for any other mode (free cooling, mechanical cooling Y1+Y2, and heating)
- Economizer damper minimum position is fully closed in unoccupied mode
- In occupied mode, the economizer damper minimum position is determined by the setting of the two potentiometers on VFD control board
 - LO SPD MIN POS potentiometer sets the minimum position when blower is operating at low speed
 - HI SPD MIN POS potentiometer sets the minimum position when blower is operating at high speed

Ordering Information

- Specify standard or high efficiency blower motor, motor horsepower and drive kit number when base unit is ordered
- See Drive Kit Specifications Table

CONTROLS

8 Unit Control

- All control voltage is provided via a 24V (secondary) transformer with built-in circuit breaker protection
- Heat/Cool Staging - Capable of up to 2 heat / 2 cool staging with a third party DDC control system or thermostat
- Low Voltage Terminal Block - Provides screw terminal connections for thermostat or controller wiring
- Night Setback Mode - Saves energy by closing outdoor air dampers and operating supply fan on thermostat demand only

Options / Accessories

Field Installed

Smoke Detector

- Photoelectric type
- Installed in supply air section, return air section or both sections
- Available with power board and single sensor (supply or return) or power board and two sensors (supply and return)
- Power board located in unit control compartment

Commercial Control Systems

Thermostats

- Control system and thermostat options see page 10

FEATURES AND BENEFITS

ELECTRICAL

- All units include terminal block and fuse block in power entry junction box for single power entry application

Marked & Color-Coded Wiring

- All electrical wiring is color-coded and marked to identify which components it is connecting

Electrical Plugs

- Positive connection electrical plugs are used to connect common accessories or maintenance parts for easy removal or installation

Options/Accessories

Phase Monitor

- Phase monitor detects the phasing of incoming power
- If the incoming power is out of phase or if any of the three phases are lost, an indicator LED on the phase monitor will turn red and the unit will not start
- Green LED indicates normal operation with correct incoming power phasing

NOTE - Phase Monitor is factory installed in the control compartment on all units equipped with the MSAV® Supply Air Blower option.

Required Selections

Voltage Choice

- Specify when ordering base unit

INDOOR AIR QUALITY

9 Air Filters

- Disposable 51 mm filters furnished as standard

Options / Accessories

Field Installed

Healthy Climate® High Efficiency Air Filters

- Disposable MERV 8 or MERV 13 (Minimum Efficiency Reporting Value based on ASHRAE 52.2) efficiency
- 51 mm pleated filters

Healthy Climate® UVC Germicidal Lamps

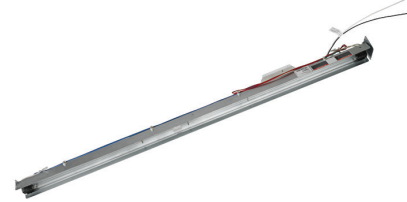

- Germicidal lamps emit ultra-violet (UV-C) energy, which has been proven to be effective in reducing microbes such as viruses, bacteria, yeasts, and molds
- This process either destroys the organism or controls its ability to reproduce
- UV-C energy greatly reduces the growth and proliferation of mold and other bioaerosols (bacteria and viruses) on illuminated surfaces (particularly coil and drain pan)
- Field installed in the blower/evaporator coil section
- Magnetic safety interlock terminates power when access panels are removed
- All necessary hardware for installation is included
- Lamps operate on 220V-1ph power supply

NOTE - Step-down transformer must be field supplied for field installation for 380/420V primary to 220V secondary.

Indoor Air Quality (CO₂) Sensors

- Monitors CO₂ levels
- Reports to the Unit Controller which adjusts economizer dampers as needed

OPTIONS / ACCESSORIES

ECONOMIZER

Factory or Field Installed

10 Economizer Features (Standard and High Performance Common Features)

- Outdoor Air Hood with mist elimination filter furnished
- Mixed Air Sensor furnished for field installation in the rooftop unit

NOTE - Sensor is factory installed when Economizer is factory installed.

Standard Economizer Features

Gear-driven action

- 24-volt, fully-modulating spring return motor
- Return air and outdoor air dampers
- Plug-in connections to unit
- Nylon bearings
- Neoprene seals

Standard Economizer Control Module

- Standard Economizer Control Module operation is based on outdoor air temperatures

Economizer Controls:

- **Damper Minimum Position** - Can be set lower than traditional minimum air requirements resulting in cost savings
- **IAQ Sensor** - Signals dampers to modulate and maintain 13°C when CO₂ is higher than the CO₂ setpoint
- **Demand Control Ventilation (DCV) LED** - A steady green Demand Control Ventilation LED indicates the IAQ reading is higher than setpoint and requires more fresh air
- **Free Cool LED** - A steady green LED indicates outdoor air is suitable for free cooling
 - Free Cooling runs when outdoor air temperature is lower than the set temperature on the economizer control.



NOTE: The Free Cooling default setting for outdoor air temperature sensor is 13°C

High Performance Economizer Features

- Gear-driven action
- High torque 24-volt fully-modulating spring return damper motor
- Return air and outdoor air dampers
- Plug-in connections to unit
- Stainless steel bearings
- Enhanced thermoplastic vulcanizate (TPV) seals
- Flexible stainless steel jamb seals

High Performance Economizer Control Module

- Provides inputs and outputs to control economizer based on parameter settings
- Automatically detects sensors by polling to determine which sensors are installed in system
- Displays any alarm messages (fault detection and diagnostics) as an aid in troubleshooting
- Non-volatile memory retains parameter settings in case of power failure
- Keypad with four navigation buttons and LCD screen is furnished for setting economizer parameters
 - Menu Up/Exit (↑) button returns to the main menu
 - Arrow Up (▲) button moves to the previous or next parameter within the selected menu
 - Arrow Down (▼) button moves to the next parameter within the selected menu
 - Select (enter) (↵) button confirms parameter selection
- Main Menu Structure:
 - **Status** (economizer and system operation status)
 - **Setpoints** (settings for various setpoint parameters)
 - **System Setup** (settings/information about the system)
 - **Advanced Setup** (freeze protection, CO₂ settings, stage 3 delay and additional calibration settings)
 - **Checkout** (damper positions)
 - **Alarms** (output signal that can be configured for remote alarm monitoring)



NOTE - Refer to Installation Instructions for complete setup information and menu parameters available.

Factory or Field Installed

Single Enthalpy Temperature Control

- Outdoor air enthalpy sensor enables economizer if the outdoor enthalpy is less than the setpoint of the control
- Single enthalpy control is furnished with economizer

Field Installed

Differential Enthalpy Control

- Order two Single Enthalpy Controls
- One is field installed in the return air section, the other in the outdoor air section
- Allows the economizer control board to select between outdoor air or return air, whichever has lower enthalpy

OPTIONS / ACCESSORIES

EXHAUST

11 Downflow Barometric Relief Dampers With Exhaust Hood

- Allow relief of excess air
- Aluminum blade dampers prevent blow back and outdoor air infiltration during off cycle
- Exhaust hood with bird screen is furnished

Field Installed

Horizontal Barometric Relief Dampers With Exhaust Hood

- For use when unit is configured for horizontal applications requiring an economizer
- Allows relief of excess air
- Aluminum blade dampers prevent blow back and outdoor air infiltration during off cycle
- Field installed in return air duct
- Exhaust hood with bird screen is furnished

12 Power Exhaust Fan

- Installs internal to unit for downflow applications only with economizer option
- Provides exhaust air pressure relief
- Interlocked to run when supply air blower is operating, fan runs when outdoor air dampers are 50% open (adjustable)
- Motor is overload protected

NOTE - Requires Economizer with Outdoor Air Hood and Downflow Barometric Relief Dampers. Dual fans are 508 mm diameter with 5 blades with (2) 0.25 kW motors.

OUTDOOR AIR

Factory or Field Installed

Outdoor Air Damper - Downflow or Horizontal With Air Hood

- Linked mechanical dampers
- 0 to 25% (fixed) outdoor air adjustable
- Installs in unit; includes outdoor air hood
- Automatic model features fully modulating spring return damper motor with plug-in connection
- Manual model features parallel blade, gear-driven dampers with adjustable fixed position

NOTE - Outdoor Air Hood is included when damper is factory installed and is furnished with damper when ordered for field installation.

ROOF CURBS

- Nailer strip furnished (downflow only)
- Mates to unit
- US National Roofing Contractors Approved
- Shipped knocked down

Downflow

Hybrid Roof Curbs

- Roof curb can be assembled using interlocking tabs to fasten corners together
- No tools required
- Curb can also be fastened together with furnished hardware
- Available in 203, 356, 457, and 610 mm heights

Adjustable Pitch Curb

- Fully adjustable pitch curb provides a level platform for rooftop units allowing flexible installations on roofs with uneven or sloped angles
- Uses interlocking tabs to fasten corners together. No tools required
- Hardware is furnished to connect upper curb with lower curb
- Available in 356 mm height

Adaptor Curbs

- Curbs are regionally sourced
- Dimensions will vary based upon the source

NOTE - Contact your local sales representative for a detailed cut sheet with applicable dimensions.

Horizontal

- Converts unit from downflow to horizontal (side) air flow
- Return air is on unit, supply air is on curb,
- See dimension drawings
- Curbs for rooftop applications meet National Roofing Code requirements

NOTE - Requires Horizontal Return Air Panel Kit. Available in 660, 762, 940 and 1041 mm heights

- Optional Insulation Kit is available to help prevent sweating

CEILING DIFFUSERS

Ceiling Diffusers (Flush or Step-Down)

- Aluminum grilles; large center grille
- Insulated diffuser box with flanges
- Hanging rings furnished
- Interior transition (even air flow)
- Internally sealed to prevent recirculation
- Adapts to T-bar ceiling grids or plaster ceilings

Transitions (Supply and Return)

- Used with diffusers
- Installs in roof curb
- Galvanized steel construction
- Flanges furnished for duct connection to diffusers
- Fully insulated

OPTIONAL CONVENTIONAL TEMPERATURE CONTROL SYSTEMS

Comfortsense® 7500 Commercial 7-Day Programmable Thermostat



- Four-Stage Heating / Two-Stage Cooling
- Universal Multi-Stage
- Intuitive Touchscreen Interface
- Automatic Changeover between Heating and Cooling
- Full Seven-Day Programming
- Four Time Periods Per Day
- Temperature and Humidity Control
- One-Touch Away Mode
- Holiday Scheduling
- Smooth Setback Recovery (SSR)
- Performance Reports
- Notifications/Reminders
- Dehumidification/Humiditrol® Control for Split Systems and Rooftop Units
- Economizer Relay Control
- Backlit Display
- Wallplate Furnished
- FDD, ASHRAE and IECC Compliant

Comfortsense® 3000 Commercial 5-2 Day Programmable Thermostat

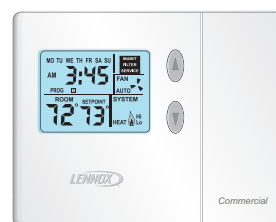

- Two-Stage Heating / Two-Stage Cooling
- Conventional Systems
- Intuitive Interface
- 5-2 Day Programming
- Program Hold
- Remote Indoor Temperature Sensing
- Smooth Setback Recovery (SSR)
- Economizer Relay Control
- Maintenance/Filter/Service Reminders
- Backlit Display
- Wallplate Furnished
- Simple Up and Down Temperature Control

BACnet Compatible Thermostat With Reheat Function



- 7-Day Programmable
- For units with or without Humiditrol®
- BTL listed MS/TP ensures compatibility with any BACnet system
- Built-in control programs for conventional and heat pump applications
- Conventional systems up to 3-stage heat and 3-stage cool
- Heat pumps with 1 or 2 compressors and up to 2-stage auxiliary heat
- On-board temperature and humidity sensor
- Multiple configurable inputs and outputs enable advanced control strategies
- Set-up Wizard enables rapid system configuration
- No special tools required for installation or commissioning
- Seven-day (2, 4 or 6 event) occupancy scheduling per day
- Backlit 5-inch LCD touchscreen

Description	Model No.	Catalog No.
Comfortsense® 7500 7-Day Programmable	C0STAT06FF2L	17G74
Universal thermostat locking guard (clear)	C0MISC15AE1-	39P21
Temperature Sensors	¹ Remote non-adjustable wall-mount 20k	47W36
	¹ Remote non-adjustable wall-mount 10k	47W37
	Remote non-adjustable discharge air (duct mount)	19L22
	Outdoor temperature sensor	X2658
Comfortsense® 3000 5-2 Day Programmable	C0STAT05FF1L	11Y05
Thermostat wall mounting plate	C0MISC17AE1-	X2659
Temperature Sensor	Remote non-adjustable wall mount 10k averaging	47W37
² 7-Day Programmable - Bacnet Compatible	---	Y8241
BACnet Controls (no reheat)	BACnet® Module (factory or field installed)	K0CTRL31C-2
	BACnet® Room Sensor with Display (field)	K0SNSR01FF1
	BACnet® Room Sensor without Display (field)	K0SNSR00FF1

¹ Remote wall-mount sensors can be applied in any of the following combinations:

- One Sensor - (1) 47W36
- Two Sensors - (2) 47W37
- Three Sensors - (2) 47W36 and (1) 47W37
- Four Sensors - (4) 47W36
- Five Sensors - (3) 47W36 and (2) 47W37

² BACnet Thermostat (Y8241) will control units with and without the Humiditrol® option. If there is a mix of units equipped with and without Humiditrol on the same site, this thermostat can be used for all units if desired.

OPTIONS / ACCESSORIES - STANDARD AND HIGH EFFICIENCY MODELS

Item Description	Model Number	Catalog Number	Unit Model No.				
			KGA 156	KGA KGB 180	KGA KGB 210	KGA KGB 240	KGB 300
COOLING SYSTEM							
Condensate Drain Trap	Polyvinyl Chloride (PVC) - C1TRAP20AD2	22H54	X	X	X	X	X
	Copper - C1TRAP10AD2	76W27	X	X	X	X	X
Corrosion Protection		Factory	O	O	O	O	O
Drain Pan Overflow Switch	C1SNSR71FF1-	10C24	X	X	X	X	X
Efficiency	Standard or High	Factory	O	O	O	O	O
Refrigerant Type		R-410A	O	O	O	O	O
HEATING SYSTEM							
Bottom Gas Piping Kit	C1GPKT01C-1	85M31	X	X	X	X	X
Combustion Air Intake Extensions (order two)	LTACA1K10/15	89L97	X	X	X	X	X
Gas Heat Input	Standard - 76.1 kW	Factory	O	O	O	O	O
	Medium - 105.4 kW	Factory	O	O	O	O	O
	High - 140.5 kW	Factory		O	O	O	O
LPG/Propane Conversion Kits (Order 2 kits)	Standard heat - C1PROP25C11	14N28	X	X	X	X	X
	Medium heat - C1PROP26C11	14N29	X	X	X	X	X
	High heat - C1PROP27C11	14N30		X	X	X	X
Stainless Steel Heat Exchanger		Factory	O	O	O	O	O
Vertical Vent Extension Kit	C1EXTN2021	42W16	X	X	X	X	X
BLOWER - SUPPLY AIR							
Blower Option	CAV (Constant Air Volume)	Factory	O	O	O	O	O
	MSAV® (Multi-Stage Air Volume)	Factory	O	O	O	O	O
Motors - Constant Air Volume (CAV)	Belt Drive (standard efficiency) - 1.5 kW (2 hp)	Factory	O				
	Belt Drive (standard efficiency) - 2.2 kW (3 hp)	Factory	O	O	O		
	Belt Drive (standard efficiency) - 3.7 kW (5 hp)	Factory	O	O	O	O	O
	Belt Drive (standard efficiency) - 5.6 kW (7.5 hp)	Factory		O	O	O	O
	Belt Drive (standard efficiency) - 7.5 kW (10 hp)	Factory				O	O
Motors - MSAV® (Multi-Stage Air Volume)	Belt Drive (standard efficiency) - 1.5 kW (2 hp)	Factory	O				
	Belt Drive (standard efficiency) - 2.2 kW (3 hp)	Factory	O	O	O		
	Belt Drive (standard efficiency) - 3.7 kW (5 hp)	Factory	O	O	O	O	O
	Belt Drive (standard efficiency) - 5.6 kW (7.5 hp)	Factory		O	O	O	O
	Belt Drive (standard efficiency) - 7.5 kW (10 hp)	Factory				O	O
Drive Kits	CAV (rev/min)	MSAV (rev/min)					
See Blower Data Tables for usage and selection	Kit #1 446-604	Kit #1 535-725	Factory	O	O	O	
	Kit #2 592-804	Kit #2 710-965	Factory	O	O	O	
	Kit #3 571-721	Kit #3 685-865	Factory	O	O	O	O
	Kit #4 708-871	Kit #4 850-1045	Factory	O	O	O	O
	Kit #5 788-988	Kit #5 945-1185	Factory	O	O	O	O
	Kit #6 708-871	Kit #6 850-1045	Factory		O	O	O
	Kit #7 788-988	Kit #7 945-1185	Factory		O	O	O
	Kit #8 871-1071	Kit #8 1045-1285	Factory		O	O	O
	Kit #9 946-1138	Kit #9 1135-1365	Factory				O
	Kit #10 871-1071	Kit #10 1045-1285	Factory				O
	Kit #11 946-1138	Kit #11 1135-1365	Factory				O
CABINET							
Hinged Access Panels		Factory	O	O	O	O	O
CONTROLS							
Smoke Detector - Supply or Return (Power board and one sensor)	C1SNSR44C-1	83W40	X	X	X	X	X
Smoke Detector - Supply and Return (Power board and two sensors)	C1SNSR43C-1	83W41	X	X	X	X	X
L Connection® Building Automation System		---	X	X	X	X	X

NOTE - Catalog and model numbers shown are for ordering field installed accessories.

OX - Configure To Order (Factory Installed) or Field Installed

O = Configure To Order (Factory Installed)

X = Field Installed

OPTIONS / ACCESSORIES - STANDARD AND HIGH EFFICIENCY MODELS

Item Description	Model Number	Catalog Number	Unit Model No.				
			KGA 156	KGA KGB 180	KGA KGB 210	KGA KGB 240	KGB 300
ELECTRICAL							
Voltage 50 hz	380/420V - 3 phase	Factory	O	O	O	O	O
INDOOR AIR QUALITY							
Air Filters							
Healthy Climate® High Efficiency Air Filters 610 x 610 x 51 mm (Order 6 per unit)	MERV 8 - C1FLTR15C-1-	54W67	X	X	X	X	X
	MERV 13 - C1FLTR40C-1-	52W40	X	X	X	X	X
Replacement Media Filter With Metal Mesh Frame (includes non-pleated filter media)	C1FLTR30C-1-	44N61	X	X	X	X	X
Indoor Air Quality (CO₂) Sensors							
Sensor - Wall-mount, off-white plastic cover with LCD display	C0SNSR50AE1L	77N39	X	X	X	X	X
Sensor - Wall-mount, off-white plastic cover, no display	C0SNSR52AE1L	87N53	X	X	X	X	X
Sensor - Black plastic case with LCD display, rated for plenum mounting	C0SNSR51AE1L	87N52	X	X	X	X	X
Sensor - Wall-mount, black plastic case, no display, rated for plenum mounting	C0MISC19AE1	87N54	X	X	X	X	X
CO ₂ Sensor Duct Mounting Kit - for downflow applications	C0MISC19AE1-	85L43	X	X	X	X	X
Aspiration Box - for duct mounting non-plenum rated CO ₂ sensors (87N53 or 77N39)	C0MISC16AE1-	90N43	X	X	X	X	X
UVC Germicidal Light Kit							
¹ Healthy Climate® UVC Light Kit (220V-1ph)	C1UVCL10C-1	54W65	X	X	X	X	X
ECONOMIZER							
Standard Economizer With Outdoor Air Hood							
Standard Economizer Downflow or Horizontal Applications - Includes Outdoor Air Hood, order Downflow or Horizontal Barometric Relief Dampers separately	K1ECON20C-3	13U48	OX	OX	OX	OX	OX
Standard Economizer Controls							
Single Enthalpy	C1SNSR64FF1	21Z09	OX	OX	OX	OX	OX
Differential Enthalpy	Order 2 - C1SNSR64FF1	21Z09	X	X	X	X	X
High Performance Economizer With Outdoor Air Hood							
High Performance Economizer Downflow or Horizontal Applications - Includes Outdoor Air Hood, order Downflow or Horizontal Barometric Relief Dampers separately	K1ECON22C-2	16X77	OX	OX	OX	OX	OX
High Performance Economizer							
Single Enthalpy Control	C1SNSR60FF1	10Z75	OX	OX	OX	OX	OX
Differential Enthalpy Control (order 2)	C1SNSR60FF1	10Z75	X	X	X	X	X
Barometric Relief Dampers With Exhaust Hood							
Downflow Barometric Relief Dampers	C1DAMP50C	54W78	OX	OX	OX	OX	OX
Horizontal Barometric Relief Dampers	LAGEDH18/24	16K99	X	X	X	X	X
OUTDOOR AIR							
Outdoor Air Dampers With Outdoor Air Hood							
Motorized	C1DAMP20C-1	13U04	OX	OX	OX	OX	OX
Manual	C1DAMP10C-2	13U05	OX	OX	OX	OX	OX
² POWER EXHAUST (DOWNFLOW APPLICATION ONLY)							
Standard Static	380/420V - C1PWRE11C-1M	75W93	X	X	X	X	X

¹ Lamps operate on 220V single-phase power supply. Step-down transformer must be field supplied for field installation for 380/420V primary to 220V secondary. Alternately, a separate 220V power supply may be used to directly power the UVC ballast(s).

² Field installed Power Exhaust requires Economizer with Outdoor Air Hood and Barometric Relief Dampers with Exhaust Hood. Must be order separately.

NOTE - Catalog and model numbers shown are for ordering field installed accessories.

OX - Configure To Order (Factory Installed) or Field Installed

O = Configure To Order (Factory Installed)

X = Field Installed

OPTIONS / ACCESSORIES - STANDARD AND HIGH EFFICIENCY MODELS

Item Description	Model Number	Catalog Number	Unit Model No.				
			KGA 156	KGA KGB 180	KGA KGB 210	KGA KGB 240	KGB 300
ROOF CURBS							
Hybrid Roof Curbs, Downflow							
203 mm height	C1CURB70C-1	11F58	X	X	X	X	X
356 mm height	C1CURB71C-1	11F59	X	X	X	X	X
457 mm height	C1CURB72C-1	11F60	X	X	X	X	X
610 mm height	C1CURB73C-1	11F61	X	X	X	X	X
Adjustable Pitched Curb, Downflow							
356 mm height	L1CURB55C	43W26	X	X	X	X	X
Standard Roof Curbs, Horizontal - Requires Horizontal Return Air Panel Kit							
660 mm height - slab applications	C1CURB14C-1	11T89	X	X	X	X	
940 mm height - rooftop applications	C1CURB15C-1	11T96	X	X	X	X	
762 mm height - slab applications	C1CURB16C-1	11T90					X
1041 mm height - rooftop applications	C1CURB17C-1	11T97					X
Insulation Kit For Standard Horizontal Curbs							
for C1CURB14C-1	C1INSU11C-1-	73K32	X	X	X	X	
for C1CURB15C-1	C1INSU13C-1-	73K34	X	X	X	X	
for C1CURB16C-1	C1INSU12C-1-	73K33					X
for C1CURB17C-1	C1INSU14C-1-	73K35					X
Horizontal Return Air Panel Kit							
Required for Horizontal Applications with Roof Curb	C1HRAP10C-1-	87M00	X	X	X	X	X
CEILING DIFFUSERS							
Step-Down - Order one	RTD11-185S	13K63	X	X			
	RTD11-275S	13K64			X	X	X
Flush - Order one	FD11-185S	13K58	X	X			
	FD11-275S	13K59			X	X	X
Transitions (Supply and Return) - Order one	C1DIFF33C-1	12X68	X	X			
	C1DIFF34C-1	12X70			X	X	X

NOTE - Catalog and model numbers shown are for ordering field installed accessories.

OX - Configure To Order (Factory Installed) or Field Installed

O = Configure To Order (Factory Installed)

X = Field Installed

OPTIONS / ACCESSORIES - STANDARD EFFICIENCY MODELS ONLY

Item Description	Model Number	Catalog Number	Unit Model No.			
			KGB 180S	KGB 210S	KGB 240S	KGB 300S
COOLING SYSTEM						
Conventional Fin/Tube Condenser Coil (replaces Environ™ Coil System)		Factory	O	O	O	O
Low Ambient Control	-1°C - K1LOAM53C11	10T63	X	X		
	-1°C - K1LOAM53C21	10T64			X	
	-1°C - K1LOAM54C21	10T65				X
	-17°C - K1LOAM63C11	18B95	X	X		
	-17°C - K1LOAM63C21	18B96			X	
	-17°C - K1LOAM64C31	18B98				X
CABINET						
Combination Coil/Hail Guards	C1GARD52C12	15T92	X	X		
	C1GARD52C22	15T93			X	X

OPTIONS / ACCESSORIES - HIGH EFFICIENCY MODELS ONLY

Item Description	Model Number	Catalog Number	Unit Model No.			
			KGA 156H	KGA 180H	KGA 210H	KGA 240H
COOLING SYSTEM						
Low Ambient Control	-1°C - K1LOAM53C11	10T63	X			
	-1°C - K1LOAM53C21	10T64		X	X	
	-1°C - K1LOAM54C21	10T65				X
	-17°C - K1LOAM63C11	18B95	X	X		
	-17°C - K1LOAM63C21	18B96			X	
	-17°C - K1LOAM64C31	18B98				X
CABINET						
Combination Coil/Hail Guards	C1GARD52C12	15T92	X			
	C1GARD52C22	15T93		X	X	X

SPECIFICATIONS - STANDARD EFFICIENCY MODELS

General Data		Nominal kW (Tons)	52.8 (15)	52.8 (15)	61.5 (17.5)	61.5 (17.5)	
		Model Number	KGB180S4B	KGB180S4M	KGB210S4B	KGB210S4M	
		Efficiency Type	Standard	Standard	Standard	Standard	
		Blower Type	CAV (Constant Air Volume)	MSAV® (Multi-Stage Air Volume)	CAV (Constant Air Volume)	MSAV® (Multi-Stage Air Volume)	
Cooling Performance	Gross Cooling Capacity - kW (Btuh)		46.3 (158 000)	46.3 (158 000)	51.9 (177 000)	51.9 (177 000)	
	¹ Net Cooling Capacity - kW (Btuh)		44.5 (152 000)	44.5 (152 000)	49.8 (170 000)	49.8 (170 000)	
	AHRI Rated Air Flow - L/s (cfm)		2832 (6000)	2832 (6000)	2690 (5700)	2690 (5700)	
	Total Unit Power - kW		16.0	16.0	18.2	18.2	
	¹ EER (Btuh/Watt) at 35°C (95°F)		10.9	10.9	10.9	10.9	
	² EER (Btuh/Watt) at 46°C (115°F)		7.8	7.8	7.8	7.8	
	¹ IEER (Btuh/Watt)		12.2	13.6	12.2	13.3	
Refrigerant Charge Furnished	Refrigerant Type		R-410A	R-410A	R-410A	R-410A	
	Environ™ Coil System	Circuit 1	2.66 kg (5 lbs. 14 oz.)	2.66 kg (5 lbs. 14 oz.)	2.95 kg (6 lbs. 8 oz.)	2.95 kg (6 lbs. 8 oz.)	
		Circuit 2	2.58 kg (5 lbs. 11 oz.)	2.58 kg (5 lbs. 11 oz.)	2.83 kg (6 lbs. 4 oz.)	2.83 kg (6 lbs. 4 oz.)	
		Circuit 3	2.64 kg (5 lbs. 13 oz.)	2.64 kg (5 lbs. 13 oz.)	2.78 kg (6 lbs. 2 oz.)	2.78 kg (6 lbs. 2 oz.)	
	Conventional Fin/Tube Coil Option	Circuit 1	5.64 kg (12 lbs. 7 oz.)	5.64 kg (12 lbs. 7 oz.)	4.99 kg (11 lbs. 0 oz.)	4.99 kg (11 lbs. 0 oz.)	
		Circuit 2	5.44 kg (12 lbs. 0 oz.)	5.44 kg (12 lbs. 0 oz.)	4.99 kg (11 lbs. 0 oz.)	4.99 kg (11 lbs. 0 oz.)	
		Circuit 3	5.07 kg (11 lbs. 3 oz.)	5.07 kg (11 lbs. 3 oz.)	4.99 kg (11 lbs. 0 oz.)	4.99 kg (11 lbs. 0 oz.)	
	Gas Heating Options Available			See page 18			
	Compressor Type (number)			Scroll (3)	Scroll (3)	Scroll (3)	Scroll (3)
Outdoor Coils	Net face area (total) - m ² (sq. ft.)		3.85 (41.4)	3.85 (41.4)	3.85 (41.4)	3.85 (41.4)	
	Number of rows		1(2)	1 (2)	1 (2)	1 (2)	
Environ™ (Fin/Tube)	Fins per m (Fins per inch)		906 (23) / 787(20)	906 (23) / 787(20)	906 (23) / 787(20)	906 (23) / 787(20)	
Outdoor Coil Fans	Motor - (No.) W (HP)		(3) 250 (1/3)	(3) 250 (1/3)	(3) 250 (1/3)	(3) 250 (1/3)	
	Motor rev/min		896	896	896	896	
	Total Motor watts		840	840	840	840	
	Diameter - (No.) mm (in.)		(3) 610 (24)	(3) 610 (24)	(3) 610 (24)	(3) 610 (24)	
	Number of blades		3	3	3	3	
	Total Air volume - L/s (cfm)		4720 (10 000)	4720 (10 000)	4720 (10 000)	4720 (10 000)	
Indoor Coils	Net face area (total) - m ² (sq. ft.)		1.99 (21.4)	1.99 (21.4)	1.99 (21.4)	1.99 (21.4)	
	Tube diameter - mm (in.)		9.5 (3/8)	9.5 (3/8)	9.5 (3/8)	9.5 (3/8)	
	Number of rows		3	3	4	4	
	Fins per m (Fins per inch)		551 (14)	551 (14)	551 (14)	551 (14)	
	Drain connection - No. and size		(1) 1 in. FPT	(1) 1 in. FPT	(1) 1 in. FPT	(1) 1 in. FPT	
			Refrigerant Metering Orifice (RFC)				
³ Indoor Blower and Drive Selection	Nominal Motor kW (HP)		2.2 (3)	2.2 (3)	2.2 (3)	2.2 (3)	
	Maximum usable motor kW (HP)		2.6 (3.45)	2.6 (3.45)	2.6 (3.45)	2.6 (3.45)	
	Kit # (rev/min range)		#3 (571-721)	#3 (685-865)	#3 (571-721)	#3 (685-865)	
			#4 (708-871)	#4 (850-1045)	#4 (708-871)	#4 (850-1045)	
	Nominal Motor kW (HP)		3.7 (5)	3.7 (5)	3.7 (5)	3.7 (5)	
	Maximum usable motor kW (HP)		4.3 (5.75)	4.3 (5.75)	4.3 (5.75)	4.3 (5.75)	
	Kit # (rev/min range)		#3 (571-721)	#3 (685-865)	#3 (571-721)	#3 (685-865)	
			#4 (708-871)	#4 (850-1045)	#4 (708-871)	#4 (850-1045)	
			#5 (788-988)	#5 (945-1185)	#5 (788-988)	#5 (945-1185)	
	Nominal Motor kW (HP)		5.6 (7.5)	5.6 (7.5)	5.6 (7.5)	5.6 (7.5)	
	Maximum usable motor kW (HP)		6.4 (8.6)	6.4 (8.6)	6.4 (8.6)	6.4 (8.6)	
	Kit # (rev/min range)		#6 (708-871)	#6 (850-1045)	#6 (708-871)	#6 (850-1045)	
			#7 (788-988)	#7 (945-1185)	#7 (788-988)	#7 (945-1185)	
			#8 (871-1071)	#8 (1045-1285)	#8 (871-1071)	#8 (1045-1285)	
	Blower wheel nominal diameter x width - mm (in.)			(2) 381 x 381 (15 x 15)			
Filters	Type of filter		Fiberglass, disposable				
	Number and size - mm (in.)		(6) 610 x 610 x 51 (24 x 24 x 2)				
Electrical characteristics			380/420V - 50 hertz - 3 phase				

NOTE - Net capacity includes evaporator blower motor heat deduction. Gross capacity does not include evaporator blower motor heat deduction.

¹ Rating test conditions are those included in Air Conditioning, Heating and Refrigeration Institute (AHRI) Standard 340/360; 35°C (95°F) outdoor air temperature and 27°C (80°F) db/19°C (67°F) wb entering evaporator air; minimum external duct static pressure while operating at rated voltage and air volumes.

² Rated at 46°C (115°F) outdoor air temperature and 27°C db/19°C (67°F) wb entering evaporator air (T3 Conditions).

³ Using total air volume and system static pressure requirements determine from blower performance tables rev/min and motor output required. Maximum usable output of motors furnished are shown. If motors of comparable output are used, be sure to keep within the service factor limitations outlined on the motor nameplate.

NOTE - Units equipped with MSAV® (Multi-Stage Air Volume) option are limited to a motor service factor of 1.0.

SPECIFICATIONS - STANDARD EFFICIENCY MODELS

General Data		Nominal kW (Tons)	70.3 (20)	70.3 (20)	88 (25)	88 (25)
		Model Number	KGB240S4B	KGB240S4M	KGB300S4B	KGB300S4M
		Efficiency Type	Standard	Standard	Standard	Standard
		Blower Type	CAV (Constant Air Volume)	MSAV® (Multi-Stage Air Volume)	CAV (Constant Air Volume)	MSAV® (Multi-Stage Air Volume)
Cooling Performance	Gross Cooling Capacity - kW (Btuh)		60.4 (206 000)	60.4 (206 000)	71.8 (245 000)	71.8 (245 000)
	¹ Net Cooling Capacity - kW (Btuh)		58.0 (198 000)	58.0 (198 000)	68.6 (234 000)	68.6 (234 000)
	AHRI Rated Air Flow - L/s (cfm)		2832 (6000)	2832 (6000)	3964 (8400)	3964 (8400)
	Total Unit Power - kW		18.0	18.0	21.9	21.9
	¹ EER (Btuh/Watt) at 35°C (95°F)		10.9	10.9	10.7	10.7
	² EER (Btuh/Watt) at 46°C (115°F)		7.7	7.7	7.7	7.7
	¹ IEER (Btuh/Watt)		12.2	13.4	11.2	13.8
Refrigerant Charge Furnished	Refrigerant Type		R-410A	R-410A	R-410A	R-410A
Refrigerant Charge Furnished	Environ™ Coil System	Circuit 1	3.18 kg (7 lbs. 0 oz.)	3.18 kg (7 lbs. 0 oz.)	2.83 kg (6 lbs. 2 oz.)	2.83 kg (6 lbs. 2 oz.)
		Circuit 2	3.15 kg (6 lbs. 15 oz.)	3.15 kg (6 lbs. 15 oz.)	2.55 kg (5 lbs. 10 oz.)	2.55 kg (5 lbs. 10 oz.)
		Circuit 3	3.06 kg (6 lbs. 12 oz.)	3.06 kg (6 lbs. 12 oz.)	2.89 kg (6 lbs. 6 oz.)	2.89 kg (6 lbs. 6 oz.)
		Circuit 4	---	---	2.72 kg (6 lbs. 0 oz.)	2.72 kg (6 lbs. 0 oz.)
	Conventional Fin/Tube Coil Option	Circuit 1	6.35 kg (14 lbs. 0 oz.)	6.35 kg (14 lbs. 0 oz.)	4.76 kg (10 lbs. 5 oz.)	4.76 kg (10 lbs. 5 oz.)
		Circuit 2	6.24 kg (13 lbs. 12 oz.)	6.24 kg (13 lbs. 12 oz.)	4.54 kg (10 lbs. 0 oz.)	4.54 kg (10 lbs. 0 oz.)
		Circuit 3	5.44 kg (12 lbs. 0 oz.)	5.44 kg (12 lbs. 0 oz.)	4.42 kg (9 lbs. 12 oz.)	4.42 kg (9 lbs. 12 oz.)
		Circuit 4	---	---	4.42 kg (9 lbs. 12 oz.)	4.42 kg (9 lbs. 12 oz.)
Gas Heating Options Available		See page 18				
Compressor Type (number)			Scroll (3)	Scroll (3)	Scroll (4)	Scroll (4)
Outdoor Coils	Net face area (total) - m ² (sq. ft.)		5.13 (55.2)	5.13 (55.2)	5.13 (55.2)	5.13 (55.2)
	Number of rows		1 (2)	1 (2)	1 (2)	1 (2)
Environ™ (Fin/Tube)	Fins per m (Fins per inch)		906 (23) / 787(20)	906 (23) / 787(20)	906 (23) / 787(20)	906 (23) / 787(20)
Outdoor Coil Fans	Motor - (No.) W (HP)		(4) 250 (1/3)	(4) 250 (1/3)	(6) 250 (1/3)	(6) 250 (1/3)
	Motor rev/min		896	896	896	896
	Total Motor watts		1146	1146	1490	1490
	Diameter - (No.) mm (in.)		(4) 610 (24)	(4) 610 (24)	(6) 610 (24)	(4) 610 (24)
	Number of blades		3	3	3	3
	Total Air volume - L/s (cfm)		6275 (13 300)	6275 (13 300)	7880 (16 700)	7880 (16 700)
Indoor Coils	Net face area (total) - m ² (sq. ft.)		1.99 (21.4)	1.99 (21.4)	1.99 (21.4)	1.99 (21.4)
	Tube diameter - mm (in.)		9.5 (3/8)	9.5 (3/8)	9.5 (3/8)	9.5 (3/8)
	Number of rows		4	4	4	4
	Fins per m (Fins per inch)		551 (14)	551 (14)	551 (14)	551 (14)
	Drain connection - No. and size		(1) 1 in. FPT	(1) 1 in. FPT	(1) 1 in. FPT	(1) 1 in. FPT
	Expansion device type		Refrigerant Metering Orifice (RFC)		Balanced Port TXV, removable head	
³ Indoor Blower and Drive Selection	Nominal Motor kW (HP)		3.7 (5)	3.7 (5)	3.7 (5)	3.7 (5)
	Maximum usable motor kW (HP)		4.3 (5.75)	4.3 (5.75)	4.3 (5.75)	4.3 (5.75)
	Kit # (rev/min range)	#3 (571-721)		#3 (685-865)	#3 (571-721)	#3 (685-865)
		#4 (708-871)		#4 (850-1045)	#4 (708-871)	#4 (850-1045)
		#5 (788-988)		#5 (945-1185)	#5 (788-988)	#5 (945-1185)
	Nominal Motor kW (HP)		5.6 (7.5)	5.6 (7.5)	5.6 (7.5)	5.6 (7.5)
	Maximum usable motor kW (HP)		6.4 (8.6)	6.4 (8.6)	6.4 (8.6)	6.4 (8.6)
	Kit # (rev/min range)	#6 (708-871)		#6 (850-1045)	#6 (708-871)	#6 (850-1045)
		#7 (788-988)		#7 (945-1185)	#7 (788-988)	#7 (945-1185)
		#8 (871-1071)		#8 (1045-1285)	#8 (871-1071)	#8 (1045-1285)
	Nominal Motor kW (HP)		7.5 (10)	7.5 (10)	7.5 (10)	7.5 (10)
Maximum usable motor kW (HP)		8.6 (11.5)	8.6 (11.5)	8.6 (11.5)	8.6 (11.5)	
Kit # (rev/min range)	#7 (788-988)		#7 (945-1185)	#7 (788-988)	#7 (945-1185)	
	#10 (871-1071)		#10 (1045-1285)	#10 (871-1071)	#10 (1045-1285)	
	#11 (945-1138)		#11 (1135-1365)	#11 (945-1138)	#11 (1135-1365)	
Blower wheel nominal diameter x width - mm (in.)		(2) 381 x 381 (15 x 15)				
Filters	Type of filter	Fiberglass, disposable				
	Number and size - mm (in.)	(6) 610 x 610 x 51 (24 x 24 x 2)				
Electrical characteristics		380/420V - 50 hertz - 3 phase				

NOTE - Net capacity includes evaporator blower motor heat deduction. Gross capacity does not include evaporator blower motor heat deduction.

¹ Rating test conditions are those included in Air Conditioning, Heating and Refrigeration Institute (AHRI) Standard 340/360; 35°C (95°F) outdoor air temperature and 27°C (80°F) db/19°C (67°F) wb entering evaporator air; minimum external duct static pressure while operating at rated voltage and air volumes.

² Rated at 46°C (115°F) outdoor air temperature and 27°C db/19°C (67°F) wb entering evaporator air (T3 Conditions).

³ Using total air volume and system static pressure requirements determine from blower performance tables rev/min and motor output required. Maximum usable output of motors furnished are shown. If motors of comparable output are used, be sure to keep within the service factor limitations outlined on the motor nameplate.

NOTE - Units equipped with MSAV® (Multi-Stage Air Volume) option are limited to a motor service factor of 1.0.

SPECIFICATIONS - HIGH EFFICIENCY MODELS

General Data		Nominal kW (Tons)	45.7 (13)	52.8 kW (15)	61.5 (17.5)	70.3 (20)
		Model Number	KGA156H4B	KGA180H4B	KGA210H4B	KGA240H4B
		Efficiency Type	High	High	High	High
		Blower Type	CAV (Constant Air Volume)	CAV (Constant Air Volume)	CAV (Constant Air Volume)	CAV (Constant Air Volume)
Cooling Performance	Gross Cooling Capacity - kW (Btuh)		38.7 (132 000)	44.8 (153 000)	51.3 (175 000)	60.1 (205 000)
	¹ Net Cooling Capacity - kW (Btuh)		37.1 (127 000)	43.4 (148 000)	49.5 (169 000)	58.0 (198 000)
	Rated Air Flow - L/s (cfm)		2360 (5000)	2482 (5259)	2890 (6125)	3020 (6400)
	Total Unit Power - kW		10.4	12.1	13.9	16.2
	¹ EER (Btuh/Watt) at 35°C (95°F)		12.2	12.2	12.2	12.2
	² EER (Btuh/Watt) at 46°C (115°F)		8.1	8.2	8.2	8.2
	¹ IEER (Btuh/Watt)		13.2	13.5	13.0	13.2
Refrigerant Charge Furnished	Refrigerant Type		R-410A	R-410A	R-410A	R-410A
	Circuit 1		2.61 kg (5 lbs. 12 oz.)	2.72 kg (6 lbs. 0 oz.)	3.06 kg (6 lbs. 12 oz.)	2.83 kg (6 lbs. 4 oz.)
	Circuit 2		2.49 kg (5 lbs. 4 oz.)	2.55 kg (5 lbs. 10 oz.)	3.12 kg (6 lbs. 14 oz.)	2.78 kg (6 lbs. 2 oz.)
	Circuit 3		2.55 kg (5 lbs. 10 oz.)	2.66 kg (5 lbs. 14 oz.)	3.12 kg (6 lbs. 14 oz.)	2.66 kg (5 lbs. 14 oz.)
	Circuit 4		---	---	---	2.44 kg (5 lbs. 6 oz.)
Gas Heating Options Available		See page 18				
Compressor Type (number)			Scroll (3)	Scroll (3)	Scroll (3)	Scroll (4)
Outdoor Coils	Net face area (total) - m ² (sq. ft.)		3.85 (41.4)	5.13 (55.2)	5.13 (55.2)	5.13 (55.2)
	Number of rows		1	1	1	1
	Fins per meter (Fins per inch)		906 (23)	906 (23)	906 (23)	906 (23)
Outdoor Coil Fans	Motor - (No.) W (HP)		(3) 1/3	(4) 1/3	(6) 1/3	(6) 1/3
	Motor rev/min		896	896	896	896
	Total Motor watts		840	1146	1490	1490
	Diameter - (No.) mm (in.)		(3) 610 (24)	(4) 610 (24)	(6) 610 (24)	(6) 610 (24)
	Number of blades		3	3	3	3
	Total Air volume - L/s (cfm)		4720 (10 000)	6275 (13 300)	7880 (16 700)	7880 (16 700)
Indoor Coils	Net face area (total) - m ² (sq. ft.)		1.99 (21.4)	1.99 (21.4)	1.99 (21.4)	1.99 (21.4)
	Tube diameter - in.		9.5 (3/8)	9.5 (3/8)	9.5 (3/8)	9.5 (3/8)
	Number of rows		3	3	4	4
	Fins per meter (Fins per inch)		551 (14)	551 (14)	551 (14)	551 (14)
	Drain connection - No. and size		(1) 1 in. FPT	(1) 1 in. FPT	(1) 1 in. FPT	(1) 1 in. FPT
	Expansion device type		Balance port TXV, removable head			
³ Indoor Blower and Drive Selection	Nominal Motor kW (HP)		1.5 (2)	2.2 (3)	2.2 (3)	3.7 (5)
	Maximum usable motor kW (HP)		1.7 (2.3)	2.6 (3.45)	2.6 (3.45)	4.3 (5.75)
	Kit # (rev/min range)	#1 (446-604)		#3 (571-721)	#3 (571-721)	#3 (571-721)
		#2 (571-721)		#4 (708-871)	#4 (708-871)	#4 (708-871)
	Nominal Motor kW (HP)		2.2 (3)	3.7 (5)	3.7 (5)	5.6 (7.5)
		Maximum usable motor kW (HP)		2.6 (3.45)	4.3 (5.75)	4.3 (5.75)
	Kit # (rev/min range)	#3 (571-721)		#3 (571-721)	#3 (571-721)	#6 (708-871)
		#4 (708-871)		#4 (708-871)	#4 (708-871)	#7 (788-988)
				#5 (788-988)	#5 (788-988)	#8 (871-1071)
	Nominal Motor kW (HP)		3.7 (5)	5.6 (7.5)	5.6 (7.5)	7.5 (10)
		Maximum usable motor kW (HP)		4.3 (5.75)	6.4 (8.6)	6.4 (8.6)
Kit # (rev/min range)	#3 (571-721)		#6 (708-871)	#6 (708-871)	#7 (788-988)	
	#4 (708-871)		#7 (788-988)	#7 (788-988)	#10 (871-1071)	
			#5 (788-988)	#8 (871-1071)	#11 (945-1138)	
Blower wheel nominal diameter x width - mm (in.)			(2) 381 x 381 (15 x 15)			
Filters Type of filter - Number and size - mm (in.)			Fiberglass, disposable - (6) 610 x 610 x 51 (24 x 24 x 2)			
Electrical characteristics			380/420V - 50 hertz - 3 phase			

NOTE - Net capacity includes evaporator blower motor heat deduction. Gross capacity does not include evaporator blower motor heat deduction.

¹ Rating test conditions are those included in Air-Conditioning, Heating and Refrigeration Institute (AHRI) Standard 340/360; 35°C (95°F) outdoor air temperature and 27°C (80°F) db/19°C (67°F) wb entering evaporator air; minimum external duct static pressure while operating at rated voltage and air volumes.

² Rated at 46°C (115°F) outdoor air temperature and 27°C db/19°C (67°F) wb entering evaporator air (T3 Conditions).

³ Using total air volume and system static pressure requirements determine from blower performance tables rev/min and motor output required. Maximum usable output of motors furnished are shown. See Belt Drive Specification Table for maximum usable motor output. If motors of comparable output are used, be sure to keep within the service factor limitations outlined on the motor nameplate.

NOTE - Units equipped with MSAV® (Multi-Stage Air Volume) option are limited to a motor service factor of 1.0.

SPECIFICATIONS - GAS HEAT

Usage Data		Model Number	KGA156 KGB180 KGB210 KGB240	KGA180 KGB180 KGA210 KGB210	KGA240 KGB240 KGB300
		Heat Input Type	Standard (S)	Medium (M)	High (H)
		Number of Gas Heat Stages	2	2	2
Gas Heating Performance	Input - kW (Btuh)	First Stage	49.5 (169 000)	68.5 (234 000)	91.4 (312 000)
		Second Stage	68.5 (234 000)	91.9 (314 000)	123.0 (420 000)
	Output - kW (Btuh)	First Stage	---	---	---
		Second Stage	54.8 (187 000)	73.5 (251 000)	98.4 (336 000)
	Temperature Rise Range - °C (°F)		8 - 25 (15 - 45)	17 - 33 (30 - 60)	22 - 39 (40 - 70)
	Thermal Efficiency		80.0%	80.0%	80.0%
Gas Supply Connections		1 in. npt	1 in. npt	1 in. npt	
Recommended Gas Supply Pressure - kPa (in. w.g.)	Natural	1.7 (7)	1.7 (7)	1.7 (7)	
	LPG/Propane	2.7 (11)	2.7 (11)	2.7 (11)	

HIGH ALTITUDE DERATE

Units may be installed at altitudes up to 610 m (2000 feet) above sea level without any modification.

At altitudes above 610 m (2000 feet), units must be derated to match gas manifold pressures shown in table below.

At altitudes above 1372 m (4500 feet) unit must be derated 2% for each 305 m (1000 feet) above sea level.

NOTE - This is the only permissible derate for these units.

Gas Heat Type	Altitude - m (ft.)	Gas Manifold Pressure kPa (in. w.g.)		Input Rate Natural Gas or LPG/Propane - kW (Btuh)	
		Natural Gas	LPG/Propane Gas	First Stage	Second Stage
Low (L)	No adjustment required				
Standard (S)	610 - 1372 (2001 - 4500)	0.52 (2.6)	1.82 (7.3)	49.5 (169 000)	66.0 (225 500)
Medium (M)	6110 - 1372 (2001 - 4500)	0.52 (2.6)	1.82 (7.3)	68.5 (233 000)	88.7 (303 400)
High (H)	6110 - 1372 (2001 - 4500)	0.52 (2.6)	1.82 (7.3)	91.4 (311 000)	118.6 (405 000)

RATINGS - STANDARD EFFICIENCY

NOTE - For Temperatures and Capacities not shown in tables, see bulletin - Cooling Unit Rating Table Correction Factor Data in Miscellaneous Engineering Data section.

52.8 kW - STANDARD EFFICIENCY KGB180S4B (1ST STAGE) - CONSTANT AIR VOLUME

Entering Wet Bulb Temperature	Total Air Volume	Outdoor Air Temperature Entering Outdoor Coil																			
		18.3°C					23.9°C					29.4°C					35°C				
		Total Cool Cap.	Comp. Motor Input	Sensible To Total Ratio (S/T)			Total Cool Cap.	Comp. Motor Input	Sensible To Total Ratio (S/T)			Total Cool Cap.	Comp. Motor Input	Sensible To Total Ratio (S/T)			Total Cool Cap.	Comp. Motor Input	Sensible To Total Ratio (S/T)		
				Dry Bulb					Dry Bulb					Dry Bulb					Dry Bulb		
L/s	kW	kW	24°C	27°C	29°C	kW	kW	24°C	27°C	29°C	kW	kW	24°C	27°C	29°C	kW	kW	24°C	27°C	29°C	
17.2°C	2265	33.0	4.53	.69	.82	.96	31.7	5.13	.70	.84	.98	30.3	5.78	.71	.86	.99	28.8	6.48	.73	.88	1.00
	2830	34.6	4.58	.73	.89	1.00	33.2	5.17	.75	.91	1.00	31.7	5.81	.76	.94	1.00	30.1	6.52	.78	.97	1.00
	3400	35.8	4.60	.78	.96	1.00	34.4	5.20	.80	.98	1.00	32.8	5.84	.81	.99	1.00	31.3	6.55	.84	1.00	1.00
19.4°C	2265	34.8	4.58	.55	.67	.78	33.5	5.18	.55	.68	.80	32.0	5.82	.56	.69	.82	30.5	6.53	.57	.70	.84
	2830	36.6	4.62	.57	.71	.85	35.1	5.22	.58	.72	.88	33.5	5.86	.59	.74	.90	31.8	6.57	.60	.76	.93
	3400	37.8	4.66	.60	.75	.93	36.2	5.25	.61	.77	.95	34.5	5.89	.62	.79	.97	32.8	6.60	.63	.82	.99
21.7°C	2265	36.6	4.63	.41	.53	.64	35.2	5.22	.42	.54	.65	33.7	5.86	.43	.54	.66	32.1	6.57	.42	.55	.68
	2830	38.5	4.67	.43	.56	.69	36.9	5.27	.43	.57	.70	35.3	5.91	.43	.58	.72	33.5	6.62	.44	.59	.73
	3400	39.7	4.71	.44	.59	.73	38.1	5.30	.44	.60	.75	36.4	5.95	.45	.61	.77	34.5	6.65	.45	.62	.79

52.8 kW - STANDARD EFFICIENCY KGB180S4B (2ND STAGE) - CONSTANT AIR VOLUME

Entering Wet Bulb Temperature	Total Air Volume	Outdoor Air Temperature Entering Outdoor Coil																			
		26.7°C					35°C					43.3°C					46°C				
		Total Cool Cap.	Comp. Motor Input	Sensible To Total Ratio (S/T)			Total Cool Cap.	Comp. Motor Input	Sensible To Total Ratio (S/T)			Total Cool Cap.	Comp. Motor Input	Sensible To Total Ratio (S/T)			Total Cool Cap.	Comp. Motor Input	Sensible To Total Ratio (S/T)		
				Dry Bulb					Dry Bulb					Dry Bulb					Dry Bulb		
L/s	kW	kW	24°C	27°C	29°C	kW	kW	24°C	27°C	29°C	kW	kW	24°C	27°C	29°C	kW	kW	24°C	27°C	29°C	
17.2°C	2265	45.2	9.04	.71	.88	1.00	41.8	10.72	.74	.93	1.00	38.3	12.73	.77	.98	1.00	37.2	13.47	.83	1.00	1.00
	2830	47.1	9.10	.76	.98	1.00	43.8	10.80	.80	1.00	1.00	40.5	12.84	.85	1.00	1.00	39.4	13.57	.91	1.00	1.00
	3400	49.0	9.17	.83	1.00	1.00	45.7	10.88	.88	1.00	1.00	42.2	12.92	.95	1.00	1.00	41.1	13.66	.97	1.00	1.00
19.4°C	2265	47.7	9.12	.56	.69	.84	44.2	10.81	.57	.71	.89	40.4	12.83	.59	.74	.95	39.2	13.56	.63	.80	.97
	2830	49.6	9.20	.59	.74	.94	45.8	10.88	.61	.77	.99	41.9	12.90	.63	.83	1.00	40.7	13.63	.67	.88	1.00
	3400	51.0	9.25	.62	.81	1.00	47.0	10.93	.64	.86	1.00	43.0	12.95	.67	.92	1.00	41.7	13.68	.72	.95	1.00
21.7°C	2265	50.1	9.22	.41	.54	.67	46.5	10.91	.42	.56	.69	42.7	12.93	.43	.58	.72	41.5	13.67	.44	.61	.78
	2830	52.2	9.30	.43	.58	.72	48.3	10.98	.43	.60	.75	44.1	13.01	.45	.62	.80	42.8	13.74	.47	.66	.86
	3400	53.5	9.35	.44	.61	.78	49.4	11.04	.45	.64	.83	45.1	13.06	.46	.66	.89	43.8	13.79	.49	.71	.93

Entering Wet Bulb Temperature	Total Air Volume	Outdoor Air Temperature Entering Outdoor Coil																	
		48°C					50°C					51.7°C							
		Total Cool Cap.	Comp. Motor Input	Sensible To Total Ratio (S/T)			Total Cool Cap.	Comp. Motor Input	Sensible To Total Ratio (S/T)			Total Cool Cap.	Comp. Motor Input	Sensible To Total Ratio (S/T)					
				Dry Bulb					Dry Bulb					Dry Bulb					
L/s	kW	kW	24°C	27°C	29°C	kW	kW	24°C	27°C	29°C	kW	kW	24°C	27°C	29°C				
17.2°C	2265	36.5	14.08	.79	1.00	1.00	35.7	14.74	.81	1.00	1.00	35.1	15.33	.82	1.00	1.00			
	2830	38.6	14.19	.89	1.00	1.00	37.8	14.85	.91	1.00	1.00	37.1	15.45	.92	1.00	1.00			
	3400	40.2	14.28	.98	1.00	1.00	39.4	14.93	.99	1.00	1.00	38.7	15.55	1.00	1.00	1.00			
19.4°C	2265	38.3	14.18	.60	.76	.98	37.4	14.82	.61	.77	.99	36.6	15.42	.61	.78	1.00			
	2830	39.7	14.24	.64	.86	1.00	38.7	14.89	.65	.88	1.00	37.9	15.49	.66	.89	1.00			
	3400	40.7	14.30	.69	.96	1.00	39.8	14.96	.69	.97	1.00	38.9	15.56	.70	.98	1.00			
21.7°C	2265	40.5	14.29	.43	.59	.74	39.6	14.94	.44	.60	.75	38.7	15.54	.44	.60	.76			
	2830	41.8	14.36	.45	.64	.83	40.8	15.01	.45	.64	.85	39.9	15.62	.46	.65	.86			
	3400	42.8	14.42	.48	.68	.93	41.8	15.07	.48	.69	.95	40.9	15.68	.48	.70	.96			

RATINGS - STANDARD EFFICIENCY

NOTE - For Temperatures and Capacities not shown in tables, see bulletin - Cooling Unit Rating Table Correction Factor Data in Miscellaneous Engineering Data section.

61.5 kW - STANDARD EFFICIENCY KGB210S4B(1ST STAGE) - CONSTANT AIR VOLUME

Entering Wet Bulb Temperature	Total Air Volume	Outdoor Air Temperature Entering Outdoor Coil																			
		18.3°C					23.9°C					29.4°C					35°C				
		Total Cool Cap.	Comp. Motor Input	Sensible To Total Ratio (S/T)			Total Cool Cap.	Comp. Motor Input	Sensible To Total Ratio (S/T)			Total Cool Cap.	Comp. Motor Input	Sensible To Total Ratio (S/T)			Total Cool Cap.	Comp. Motor Input	Sensible To Total Ratio (S/T)		
				Dry Bulb					Dry Bulb					Dry Bulb					Dry Bulb		
L/s	kW	kW	24°C	27°C	29°C	kW	kW	24°C	27°C	29°C	kW	kW	24°C	27°C	29°C	kW	kW	24°C	27°C	29°C	
17.2°C	2645	41.4	5.57	.67	.82	.99	38.6	6.28	.68	.84	1.00	35.6	7.05	.68	.87	1.00	32.5	7.94	.69	.90	1.00
	3305	43.9	5.63	.73	.92	1.00	40.9	6.34	.74	.95	1.00	37.8	7.12	.75	.98	1.00	34.6	8.01	.77	.99	1.00
	3965	45.8	5.68	.78	.99	1.00	42.9	6.40	.81	1.00	1.00	39.9	7.19	.83	1.00	1.00	36.9	8.08	.86	1.00	1.00
19.4°C	2645	44.6	5.65	.53	.65	.78	41.6	6.36	.52	.66	.80	38.5	7.14	.52	.66	.82	35.2	8.02	.52	.67	.86
	3305	46.9	5.71	.56	.71	.88	43.8	6.43	.56	.72	.91	40.4	7.20	.56	.73	.94	37.0	8.09	.56	.75	.98
	3965	48.6	5.76	.60	.76	.97	45.2	6.47	.60	.77	.99	41.8	7.25	.60	.81	1.00	38.3	8.13	.60	.84	1.00
21.7°C	2645	47.8	5.73	.40	.52	.63	44.7	6.45	.39	.52	.64	41.4	7.24	.38	.51	.65	38.0	8.13	.36	.51	.66
	3305	50.1	5.80	.41	.56	.69	46.9	6.52	.41	.56	.70	43.4	7.31	.40	.56	.71	39.7	8.20	.39	.56	.73
	3965	51.8	5.85	.43	.58	.74	48.4	6.58	.43	.59	.76	44.8	7.36	.41	.60	.79	41.0	8.24	.41	.60	.81

61.5 kW - STANDARD EFFICIENCY KGB210S4B (2ND STAGE) - CONSTANT AIR VOLUME

Entering Wet Bulb Temperature	Total Air Volume	Outdoor Air Temperature Entering Outdoor Coil																			
		26.7°C					35°C					43.3°C					46°C				
		Total Cool Cap.	Comp. Motor Input	Sensible To Total Ratio (S/T)			Total Cool Cap.	Comp. Motor Input	Sensible To Total Ratio (S/T)			Total Cool Cap.	Comp. Motor Input	Sensible To Total Ratio (S/T)			Total Cool Cap.	Comp. Motor Input	Sensible To Total Ratio (S/T)		
				Dry Bulb					Dry Bulb					Dry Bulb					Dry Bulb		
L/s	kW	kW	24°C	27°C	29°C	kW	kW	24°C	27°C	29°C	kW	kW	24°C	27°C	29°C	kW	kW	24°C	27°C	29°C	
17.2°C	2645	54.6	10.50	.69	.88	1.00	47.7	12.50	.71	.93	1.00	40.6	15.01	.73	.97	1.00	38.5	15.94	.79	.99	1.00
	3305	57.9	10.62	.76	.98	1.00	51.0	12.65	.79	1.00	1.00	44.1	15.17	.85	1.00	1.00	41.9	16.10	.90	1.00	1.00
	3965	61.1	10.75	.84	1.00	1.00	54.1	12.78	.89	1.00	1.00	46.8	15.30	.95	1.00	1.00	44.5	16.24	.97	1.00	1.00
19.4°C	2645	58.8	10.65	.53	.68	.84	51.5	12.66	.53	.69	.89	43.8	15.16	.52	.72	.94	41.4	16.08	.54	.77	.97
	3305	61.7	10.76	.57	.74	.95	53.8	12.77	.57	.77	.98	45.9	15.26	.58	.82	1.00	43.4	16.18	.61	.88	1.00
	3965	63.7	10.85	.61	.82	1.00	55.7	12.85	.62	.87	1.00	47.6	15.33	.64	.93	1.00	45.0	16.25	.68	.96	1.00
21.7°C	2645	63.0	10.82	.39	.52	.66	55.4	12.84	.36	.52	.67	47.5	15.33	.34	.52	.70	45.0	16.25	.34	.54	.75
	3305	65.9	10.94	.41	.57	.72	57.8	12.96	.39	.57	.75	49.6	15.44	.37	.58	.80	46.9	16.34	.37	.62	.86
	3965	67.9	11.04	.43	.61	.80	59.5	13.05	.41	.62	.85	51.1	15.53	.40	.64	.91	48.4	16.43	.41	.69	.95

Entering Wet Bulb Temperature	Total Air Volume	Outdoor Air Temperature Entering Outdoor Coil																	
		48°C					50°C					51.7°C							
		Total Cool Cap.	Comp. Motor Input	Sensible To Total Ratio (S/T)			Total Cool Cap.	Comp. Motor Input	Sensible To Total Ratio (S/T)			Total Cool Cap.	Comp. Motor Input	Sensible To Total Ratio (S/T)					
				Dry Bulb					Dry Bulb					Dry Bulb					
L/s	kW	kW	24°C	27°C	29°C	kW	kW	24°C	27°C	29°C	kW	kW	24°C	27°C	29°C				
17.2°C	2645	36.8	16.76	.75	.99	1.00	35.1	17.63	.76	1.00	1.00	33.6	18.42	.78	1.00	1.00			
	3305	40.2	16.90	.89	1.00	1.00	38.4	17.77	.91	1.00	1.00	36.8	18.59	.92	1.00	1.00			
	3965	42.6	17.02	.98	1.00	1.00	40.9	17.88	.99	1.00	1.00	39.2	18.71	.99	1.00	1.00			
19.4°C	2645	39.5	16.88	.52	.73	.97	37.6	17.74	.52	.75	.98	35.9	18.56	.52	.76	.99			
	3305	41.4	16.97	.59	.87	1.00	39.4	17.82	.59	.89	1.00	37.7	18.61	.60	.90	1.00			
	3965	43.0	17.05	.65	.96	1.00	41.1	17.90	.66	.97	1.00	39.3	18.72	.66	.98	1.00			
21.7°C	2645	43.0	17.04	.32	.52	.72	41.1	17.90	.31	.52	.73	39.2	18.70	.31	.52	.74			
	3305	44.9	17.14	.36	.59	.84	42.8	17.99	.35	.60	.86	41.0	18.79	.35	.60	.88			
	3965	46.3	17.21	.39	.66	.94	44.1	18.04	.39	.67	.96	42.2	18.87	.38	.67	.97			

RATINGS - STANDARD EFFICIENCY

NOTE - For Temperatures and Capacities not shown in tables, see bulletin - Cooling Unit Rating Table Correction Factor Data in Miscellaneous Engineering Data section.

70.3 kW - STANDARD EFFICIENCY KGB240S4B (1ST STAGE) - CONSTANT AIR VOLUME

Entering Wet Bulb Temperature	Total Air Volume	Outdoor Air Temperature Entering Outdoor Coil																			
		18.3°C					23.9°C					29.4°C					35°C				
		Total Cool Cap.	Comp. Motor Input	Sensible To Total Ratio (S/T)			Total Cool Cap.	Comp. Motor Input	Sensible To Total Ratio (S/T)			Total Cool Cap.	Comp. Motor Input	Sensible To Total Ratio (S/T)			Total Cool Cap.	Comp. Motor Input	Sensible To Total Ratio (S/T)		
				Dry Bulb					Dry Bulb					Dry Bulb					Dry Bulb		
L/s	kW	kW	24°C	27°C	29°C	kW	kW	24°C	27°C	29°C	kW	kW	24°C	27°C	29°C	kW	kW	24°C	27°C	29°C	
17.2°C	3020	44.2	6.24	.73	.88	1.00	41.9	6.94	.74	.89	1.00	39.4	7.71	.76	.91	1.00	36.8	8.57	.77	.94	1.00
	3775	46.4	6.26	.79	.95	1.00	44.0	6.97	.81	.97	1.00	41.4	7.74	.82	.99	1.00	38.7	8.60	.84	1.00	1.00
	4530	48.2	6.29	.85	1.00	1.00	45.8	7.00	.86	1.00	1.00	43.5	7.78	.88	1.00	1.00	40.9	8.64	.91	1.00	1.00
19.4°C	3020	47.0	6.27	.58	.71	.84	44.6	6.98	.58	.72	.86	42.0	7.75	.59	.74	.88	39.3	8.61	.60	.75	.91
	3775	49.2	6.30	.62	.77	.92	46.6	7.01	.62	.79	.94	43.8	7.79	.63	.80	.97	40.9	8.64	.63	.82	.99
	4530	50.8	6.32	.65	.83	.99	48.0	7.03	.65	.84	1.00	45.1	7.81	.66	.86	1.00	42.0	8.67	.67	.89	1.00
21.7°C	3020	49.9	6.30	.43	.56	.69	47.4	7.03	.43	.57	.70	44.7	7.80	.43	.58	.71	41.8	8.67	.42	.59	.73
	3775	52.3	6.34	.46	.61	.75	49.5	7.06	.45	.61	.77	46.5	7.84	.45	.62	.78	43.3	8.70	.45	.62	.80
	4530	53.7	6.36	.47	.64	.81	50.8	7.08	.47	.64	.82	47.7	7.86	.47	.66	.84	44.5	8.73	.46	.67	.87

70.3 kW - STANDARD EFFICIENCY KGB240S4B (2ND STAGE) - CONSTANT AIR VOLUME

Entering Wet Bulb Temperature	Total Air Volume	Outdoor Air Temperature Entering Outdoor Coil																			
		26.7°C					35°C					43.3°C					46°C				
		Total Cool Cap.	Comp. Motor Input	Sensible To Total Ratio (S/T)			Total Cool Cap.	Comp. Motor Input	Sensible To Total Ratio (S/T)			Total Cool Cap.	Comp. Motor Input	Sensible To Total Ratio (S/T)			Total Cool Cap.	Comp. Motor Input	Sensible To Total Ratio (S/T)		
				Dry Bulb					Dry Bulb					Dry Bulb					Dry Bulb		
L/s	kW	kW	24°C	27°C	29°C	kW	kW	24°C	27°C	29°C	kW	kW	24°C	27°C	29°C	kW	kW	24°C	27°C	29°C	
17.2°C	3020	63.0	12.24	.77	.93	1.00	56.6	14.28	.79	.96	1.00	50.3	16.76	.82	.98	1.00	48.5	17.67	.83	.99	1.00
	3775	66.2	12.35	.83	.99	1.00	60.0	14.40	.87	1.00	1.00	53.6	16.89	.91	1.00	1.00	51.6	17.80	.92	1.00	1.00
	4530	69.3	12.44	.90	1.00	1.00	62.8	14.51	.93	1.00	1.00	56.2	17.00	.97	1.00	1.00	54.2	17.91	.98	1.00	1.00
19.4°C	3020	67.1	12.38	.59	.75	.90	60.3	14.43	.60	.77	.93	53.4	16.89	.61	.80	.97	51.2	17.79	.61	.81	.98
	3775	69.8	12.48	.63	.82	.97	62.7	14.52	.65	.85	.99	55.4	16.98	.66	.89	1.00	53.2	17.88	.67	.90	1.00
	4530	71.8	12.55	.68	.88	1.00	64.4	14.59	.69	.92	1.00	57.1	17.06	.72	.96	1.00	54.8	17.95	.73	.97	1.00
21.7°C	3020	71.2	12.52	.43	.59	.73	64.2	14.57	.43	.59	.75	56.9	17.05	.42	.60	.78	54.7	17.94	.41	.61	.79
	3775	74.0	12.62	.45	.63	.80	66.5	14.68	.45	.64	.83	59.0	17.13	.44	.66	.87	56.7	18.03	.44	.66	.88
	4530	76.0	12.69	.47	.67	.86	68.3	14.75	.47	.69	.90	60.4	17.20	.47	.72	.95	58.1	18.10	.46	.73	.96

Entering Wet Bulb Temperature	Total Air Volume	Outdoor Air Temperature Entering Outdoor Coil																	
		48°C					50°C					51.7°C							
		Total Cool Cap.	Comp. Motor Input	Sensible To Total Ratio (S/T)			Total Cool Cap.	Comp. Motor Input	Sensible To Total Ratio (S/T)			Total Cool Cap.	Comp. Motor Input	Sensible To Total Ratio (S/T)					
				Dry Bulb					Dry Bulb					Dry Bulb					
L/s	kW	kW	24°C	27°C	29°C	kW	kW	24°C	27°C	29°C	kW	kW	24°C	27°C	29°C				
17.2°C	3020	47.1	18.44	.84	.99	1.00	45.6	19.25	.85	1.00	1.00	44.5	20.01	.86	1.00	1.00			
	3775	50.1	18.56	.93	1.00	1.00	48.8	19.37	.94	1.00	1.00	47.7	20.14	.95	1.00	1.00			
	4530	52.7	18.67	.98	1.00	1.00	51.2	19.48	.99	1.00	1.00	49.9	20.24	.99	1.00	1.00			
19.4°C	3020	49.6	18.55	.61	.82	.98	48.0	19.36	.61	.83	.98	46.7	20.12	.62	.83	.99			
	3775	51.6	18.63	.67	.91	1.00	50.1	19.45	.67	.92	1.00	48.7	20.21	.68	.93	1.00			
	4530	53.0	18.70	.73	.98	1.00	51.5	19.50	.74	.98	1.00	50.1	20.24	.74	.98	1.00			
21.7°C	3020	53.0	18.71	.41	.61	.80	51.4	19.50	.41	.61	.81	50.1	20.27	.40	.62	.81			
	3775	54.9	18.78	.44	.67	.89	53.3	19.58	.44	.67	.91	51.9	20.33	.43	.68	.91			
	4530	56.3	18.85	.47	.73	.97	54.6	19.64	.47	.74	.97	53.1	20.39	.47	.74	.98			

RATINGS - STANDARD EFFICIENCY

NOTE - For Temperatures and Capacities not shown in tables, see bulletin - Cooling Unit Rating Table Correction Factor Data in Miscellaneous Engineering Data section.

88 kW - STANDARD EFFICIENCY KGB300S4B (1ST STAGE) - CONSTANT AIR VOLUME

Entering Wet Bulb Temperature	Total Air Volume	Outdoor Air Temperature Entering Outdoor Coil																				
		18.3°C						23.9°C					29.4°C					35°C				
		Total Cool Cap.	Comp. Motor Input	Sensible To Total Ratio (S/T)			Total Cool Cap.	Comp. Motor Input	Sensible To Total Ratio (S/T)			Total Cool Cap.	Comp. Motor Input	Sensible To Total Ratio (S/T)			Total Cool Cap.	Comp. Motor Input	Sensible To Total Ratio (S/T)			
				Dry Bulb					Dry Bulb					Dry Bulb					Dry Bulb			
L/s	kW	kW	24°C	27°C	29°C	kW	kW	24°C	27°C	29°C	kW	kW	24°C	27°C	29°C	kW	kW	24°C	27°C	29°C		
17.2°C	3775	38	5.26	0.72	0.87	0.99	36.3	5.94	0.74	0.9	1	34.7	6.71	0.75	0.92	1	33.3	7.59	0.78	0.95	1	
	4485	39.4	5.3	0.76	0.93	1	37.6	5.99	0.79	0.96	1	35.9	6.76	0.8	0.98	1	34.4	7.64	0.82	0.99	1	
	5190	40.5	5.34	0.81	0.98	1	38.6	6.03	0.83	0.99	1	37	6.8	0.85	1	1	35.5	7.68	0.87	1	1	
19.4°C	3775	40.1	5.33	0.57	0.7	0.84	38.2	6.02	0.58	0.71	0.86	36.6	6.79	0.59	0.74	0.88	35	7.66	0.6	0.75	0.91	
	4485	41.4	5.37	0.59	0.74	0.9	39.6	6.07	0.61	0.77	0.93	37.7	6.83	0.62	0.78	0.95	36	7.7	0.63	0.8	0.97	
	5190	42.5	5.41	0.62	0.79	0.96	40.4	6.1	0.64	0.81	0.98	38.5	6.86	0.64	0.83	0.99	36.7	7.74	0.65	0.85	1	
21.7°C	3775	42.5	5.41	0.43	0.56	0.68	40.5	6.1	0.43	0.57	0.69	38.6	6.87	0.45	0.58	0.72	36.9	7.75	0.44	0.59	0.73	
	4485	43.7	5.46	0.44	0.58	0.72	41.7	6.15	0.44	0.6	0.74	39.8	6.92	0.45	0.61	0.76	37.9	7.8	0.45	0.62	0.78	
	5190	44.7	5.5	0.44	0.61	0.76	42.6	6.19	0.44	0.63	0.78	40.5	6.95	0.45	0.63	0.8	38.6	7.83	0.47	0.65	0.83	

88 kW - STANDARD EFFICIENCY KGB300S4B (2ND STAGE) - CONSTANT AIR VOLUME

Entering Wet Bulb Temperature	Total Air Volume	Outdoor Air Temperature Entering Outdoor Coil																				
		26.7°C						35°C					43.3°C					46°C				
		Total Cool Cap.	Comp. Motor Input	Sensible To Total Ratio (S/T)			Total Cool Cap.	Comp. Motor Input	Sensible To Total Ratio (S/T)			Total Cool Cap.	Comp. Motor Input	Sensible To Total Ratio (S/T)			Total Cool Cap.	Comp. Motor Input	Sensible To Total Ratio (S/T)			
				Dry Bulb					Dry Bulb					Dry Bulb					Dry Bulb			
L/s	kW	kW	24°C	27°C	29°C	kW	kW	24°C	27°C	29°C	kW	kW	24°C	27°C	29°C	kW	kW	24°C	27°C	29°C		
17.2°C	3775	73.2	14	0.76	0.92	1	68.2	16.58	0.78	0.96	1	63.1	19.77	0.81	0.99	1	61.5	20.96	.84	1.00	1.00	
	4485	75.6	14.13	0.8	0.98	1	70.4	16.71	0.83	1	1	65.6	19.94	0.87	1	1	64.1	21.14	.90	1.00	1.00	
	5190	77.8	14.25	0.85	1	1	72.9	16.86	0.88	1	1	67.8	20.08	0.93	1	1	66.3	21.29	.95	1.00	1.00	
19.4°C	3775	77.2	14.22	0.59	0.73	0.88	71.8	16.8	0.61	0.76	0.92	66.4	19.98	0.62	0.79	0.97	64.6	21.17	.64	.82	.98	
	4485	79.5	14.35	0.62	0.78	0.95	73.8	16.92	0.64	0.81	0.99	68.1	20.1	0.66	0.85	1	66.3	21.28	.67	.88	1.00	
	5190	81.2	14.45	0.64	0.82	1	75.3	17.02	0.66	0.86	1	69.4	20.19	0.69	0.91	1	67.6	21.37	.71	.93	1.00	
21.7°C	3775	81.5	14.46	0.44	0.58	0.71	75.8	17.05	0.44	0.6	0.74	70	20.23	0.45	0.62	0.77	68.1	21.41	.46	.63	.80	
	4485	83.8	14.6	0.45	0.61	0.76	77.7	17.16	0.46	0.63	0.79	71.7	20.34	0.47	0.65	0.83	69.8	21.53	.48	.67	.85	
	5190	85.5	14.69	0.46	0.64	0.8	79.2	17.26	0.47	0.65	0.84	73.1	20.43	0.48	0.68	0.88	71.0	21.61	.49	.71	.91	

Entering Wet Bulb Temperature	Total Air Volume	Outdoor Air Temperature Entering Outdoor Coil																	
		48°C						50°C					51.7°C						
		Total Cool Cap.	Comp. Motor Input	Sensible To Total Ratio (S/T)			Total Cool Cap.	Comp. Motor Input	Sensible To Total Ratio (S/T)			Total Cool Cap.	Comp. Motor Input	Sensible To Total Ratio (S/T)					
				Dry Bulb					Dry Bulb					Dry Bulb					
L/s	kW	kW	24°C	27°C	29°C	kW	kW	24°C	27°C	29°C	kW	kW	24°C	27°C	29°C				
17.2°C	3775	60.2	21.98	.83	1.00	1.00	59.0	23.07	.84	1.00	1.00	58	24.1	0.85	1	1			
	4485	62.8	22.16	.90	1.00	1.00	61.6	23.26	.91	1.00	1.00	60.5	24.27	0.92	1	1			
	5190	64.9	22.29	.96	1.00	1.00	63.5	23.39	.97	1.00	1.00	62.4	24.4	0.98	1	1			
19.4°C	3775	63.2	22.18	.63	.81	.99	61.8	23.27	.64	.82	1.00	60.4	24.25	0.65	0.83	1			
	4485	64.9	22.29	.67	.87	1.00	63.3	23.37	.68	.88	1.00	62	24.38	0.68	0.9	1			
	5190	66.1	22.37	.70	.94	1.00	64.6	23.46	.71	.95	1.00	63.2	24.45	0.72	0.96	1			
21.7°C	3775	66.7	22.43	.46	.63	.79	65.1	23.50	.46	.63	.80	63.8	24.49	0.47	0.64	0.81			
	4485	68.2	22.52	.48	.66	.85	66.7	23.61	.48	.67	.86	65.4	24.61	0.48	0.68	0.88			
	5190	69.4	22.62	.49	.70	.92	67.8	23.69	.49	.70	.93	66.4	24.68	0.49	0.71	0.94			

RATINGS - STANDARD EFFICIENCY

NOTE - For Temperatures and Capacities not shown in tables, see bulletin - Cooling Unit Rating Table Correction Factor Data in Miscellaneous Engineering Data section.

52.8 KW - STANDARD EFFICIENCY KGB180S4M (1ST STAGE) - MSAV® (MULTI-STAGE AIR VOLUME) SUPPLY AIR BLOWER

Entering Wet Bulb Temperature	Total Air Volume	Outdoor Air Temperature Entering Outdoor Coil																			
		18.3°C					23.9°C					29.4°C					35°C				
		Total Cool Cap.	Comp. Motor Input	Sensible To Total Ratio (S/T)			Total Cool Cap.	Comp. Motor Input	Sensible To Total Ratio (S/T)			Total Cool Cap.	Comp. Motor Input	Sensible To Total Ratio (S/T)			Total Cool Cap.	Comp. Motor Input	Sensible To Total Ratio (S/T)		
				Dry Bulb					Dry Bulb					Dry Bulb					Dry Bulb		
L/s	kW	kW	24°C	27°C	29°C	kW	kW	24°C	27°C	29°C	kW	kW	24°C	27°C	29°C	kW	kW	24°C	27°C	29°C	
17.2°C	1650	31.5	4.39	0.67	0.79	0.9	30.4	5.03	0.68	0.8	0.92	29.2	5.68	0.69	0.81	0.94	27.8	6.38	0.7	0.83	0.96
	1890	32.7	4.39	0.69	0.82	0.94	31.5	5.04	0.7	0.83	0.96	30.2	5.67	0.71	0.85	0.98	28.8	6.37	0.72	0.86	1
	2125	33.7	4.39	0.71	0.85	0.98	32.4	5.03	0.72	0.86	0.99	31.1	5.69	0.73	0.88	1	29.7	6.39	0.75	0.9	1
19.4°C	1650	33.4	4.4	0.54	0.65	0.75	32.2	5.04	0.55	0.65	0.76	30.9	5.67	0.55	0.66	0.77	29.6	6.37	0.56	0.67	0.79
	1890	34.6	4.39	0.55	0.67	0.78	33.4	5.03	0.55	0.68	0.79	32.1	5.68	0.56	0.69	0.81	30.7	6.38	0.57	0.7	0.83
	2125	35.7	4.4	0.56	0.69	0.81	34.4	5.04	0.57	0.7	0.83	33	5.69	0.57	0.71	0.84	31.6	6.39	0.58	0.72	0.86
21.7°C	1650	35.2	4.4	0.42	0.52	0.62	34	5.04	0.42	0.53	0.63	32.9	5.68	0.43	0.53	0.64	31.4	6.37	0.42	0.54	0.65
	1890	36.5	4.41	0.42	0.54	0.64	35.2	5.04	0.43	0.54	0.65	34	5.69	0.43	0.54	0.66	32.5	6.39	0.43	0.55	0.67
	2125	37.7	4.42	0.43	0.55	0.66	36.3	5.05	0.43	0.55	0.67	35	5.7	0.43	0.56	0.68	33.5	6.39	0.43	0.57	0.69

52.8 KW - STANDARD EFFICIENCY KGB180S4M (2ND STAGE) - MSAV® (MULTI-STAGE AIR VOLUME) SUPPLY AIR BLOWER

Entering Wet Bulb Temperature	Total Air Volume	Outdoor Air Temperature Entering Outdoor Coil																			
		26.7°C					35°C					43.3°C					46°C				
		Total Cool Cap.	Comp. Motor Input	Sensible To Total Ratio (S/T)			Total Cool Cap.	Comp. Motor Input	Sensible To Total Ratio (S/T)			Total Cool Cap.	Comp. Motor Input	Sensible To Total Ratio (S/T)			Total Cool Cap.	Comp. Motor Input	Sensible To Total Ratio (S/T)		
				Dry Bulb					Dry Bulb					Dry Bulb					Dry Bulb		
L/s	kW	kW	24°C	27°C	29°C	kW	kW	24°C	27°C	29°C	kW	kW	24°C	27°C	29°C	kW	kW	24°C	27°C	29°C	
17.2°C	2265	46.7	8.23	0.73	0.88	1.00	43	9.8	0.75	0.91	1.00	39	11.75	0.76	0.95	1.00	37.6	12.49	0.78	0.96	1.00
	2832	49.1	8.23	0.78	0.95	1.00	45.2	9.81	0.79	0.98	1.00	41.1	11.77	0.82	1.00	1.00	39.7	12.51	0.84	1.00	1.00
	3398	50.8	8.24	0.81	1.00	1.00	46.9	9.82	0.84	1.00	1.00	42.8	11.77	0.87	1.00	1.00	41.5	12.50	0.88	1.00	1.00
19.4°C	2265	49.3	8.24	0.57	0.71	0.84	45.5	9.8	0.58	0.72	0.87	41.5	11.76	0.59	0.74	0.9	40.1	12.49	0.59	0.76	0.92
	2832	51.8	8.24	0.6	0.76	0.92	47.6	9.8	0.60	0.77	0.95	43.2	11.77	0.61	0.79	0.98	41.7	12.48	0.62	0.81	0.99
	3398	53.3	8.24	0.62	0.79	0.98	49.1	9.81	0.63	0.82	1.00	44.3	11.75	0.64	0.84	1.00	42.8	12.51	0.65	0.86	1.00
21.7°C	2265	51.7	8.23	0.44	0.56	0.68	47.7	9.81	0.42	0.56	0.7	43.3	11.77	0.40	0.57	0.72	41.8	12.52	0.40	0.58	0.73
	2832	53.7	8.24	0.41	0.59	0.73	49.4	9.82	0.42	0.6	0.75	44.9	11.76	0.42	0.6	0.77	43.2	12.52	0.43	0.61	0.79
	3398	55.2	8.23	0.45	0.62	0.77	50.5	9.81	0.45	0.62	0.79	45.6	11.78	0.39	0.63	0.82	43.9	12.52	0.39	0.64	0.84

Entering Wet Bulb Temperature	Total Air Volume	Outdoor Air Temperature Entering Outdoor Coil																		
		48°C					50°C					51.7°C								
		Total Cool Cap.	Comp. Motor Input	Sensible To Total Ratio (S/T)			Total Cool Cap.	Comp. Motor Input	Sensible To Total Ratio (S/T)			Total Cool Cap.	Comp. Motor Input	Sensible To Total Ratio (S/T)						
				Dry Bulb					Dry Bulb					Dry Bulb						
L/s	kW	kW	24°C	27°C	29°C	kW	kW	24°C	27°C	29°C	kW	kW	24°C	27°C	29°C					
17.2°C	2265	36.6	13.11	0.79	0.97	1.00	35.6	13.77	0.80	0.98	1.00	34.7	14.35	0.79	0.99	1.00				
	2832	38.7	13.12	0.84	1.00	1.00	37.7	13.77	0.85	1.00	1.00	36.8	14.37	0.85	1.00	1.00				
	3398	40.4	13.13	0.89	1.00	1.00	39.2	13.78	0.90	1.00	1.00	38.4	14.37	0.90	1.00	1.00				
19.4°C	2265	38.9	13.10	0.59	0.76	0.93	37.9	13.76	0.59	0.77	0.94	36.9	14.33	0.59	0.76	0.95				
	2832	40.6	13.09	0.62	0.82	1.00	39.4	13.74	0.63	0.83	1.00	38.4	14.33	0.62	0.82	1.00				
	3398	41.5	13.12	0.66	0.87	1.00	40.3	13.79	0.66	0.88	1.00	39.2	14.39	0.65	0.88	1.00				
21.7°C	2265	40.7	13.12	0.40	0.59	0.74	39.4	13.79	0.41	0.59	0.75	38.5	14.36	0.42	0.58	0.74				
	2832	42.0	13.14	0.40	0.61	0.79	40.7	13.80	0.40	0.62	0.80	39.6	14.39	0.38	0.62	0.80				
	3398	42.6	13.15	0.39	0.65	0.85	41.4	13.80	0.40	0.65	0.85	40.2	14.41	0.4	0.65	0.85				

RATINGS - STANDARD EFFICIENCY

NOTE - For Temperatures and Capacities not shown in tables, see bulletin - Cooling Unit Rating Table Correction Factor Data in Miscellaneous Engineering Data section.

61.5 KW - STANDARD EFFICIENCY KGB210S4M (1ST STAGE) - MSAV® (MULTI-STAGE AIR VOLUME) SUPPLY AIR BLOWER

Entering Wet Bulb Temperature	Total Air Volume	Outdoor Air Temperature Entering Outdoor Coil																			
		18.3°C					23.9°C					29.4°C					35°C				
		Total Cool Cap.	Comp. Motor Input	Sensible To Total Ratio (S/T)			Total Cool Cap.	Comp. Motor Input	Sensible To Total Ratio (S/T)			Total Cool Cap.	Comp. Motor Input	Sensible To Total Ratio (S/T)			Total Cool Cap.	Comp. Motor Input	Sensible To Total Ratio (S/T)		
				Dry Bulb					Dry Bulb					Dry Bulb					Dry Bulb		
L/s	kW	kW	24°C	27°C	29°C	kW	kW	24°C	27°C	29°C	kW	kW	24°C	27°C	29°C	kW	kW	24°C	27°C	29°C	
17.2°C	1890	37.2	5.62	0.67	0.78	0.9	35.8	6.33	0.67	0.79	0.91	34.2	7.12	0.68	0.81	0.93	32.7	8.02	0.69	0.83	0.95
	2240	38.9	5.7	0.7	0.83	0.95	37.4	6.41	0.7	0.84	0.97	35.8	7.2	0.71	0.86	0.99	34.1	8.1	0.73	0.88	1.00
	2595	40.3	5.76	0.73	0.87	1.00	38.7	6.47	0.73	0.89	1.00	37.1	7.27	0.75	0.91	1.00	35.3	8.17	0.77	0.93	1.00
19.4°C	1890	39.6	5.73	0.54	0.64	0.75	38.1	6.45	0.54	0.65	0.76	36.5	7.24	0.55	0.66	0.77	34.8	8.14	0.55	0.67	0.79
	2240	41.4	5.81	0.56	0.67	0.79	39.8	6.52	0.56	0.68	0.8	38	7.32	0.57	0.69	0.82	36.3	8.23	0.58	0.71	0.84
	2595	42.8	5.88	0.57	0.7	0.83	41.1	6.59	0.58	0.71	0.85	39.3	7.39	0.59	0.72	0.87	37.4	8.3	0.6	0.74	0.89
21.7°C	1890	42.1	5.85	0.42	0.52	0.62	40.5	6.56	0.42	0.52	0.63	38.9	7.37	0.42	0.53	0.63	37.1	8.28	0.42	0.54	0.64
	2240	44.2	5.94	0.43	0.54	0.65	42.3	6.66	0.43	0.54	0.66	40.5	7.46	0.43	0.55	0.67	38.7	8.37	0.43	0.56	0.68
	2595	45.5	6	0.43	0.55	0.68	43.8	6.73	0.44	0.57	0.69	41.8	7.53	0.44	0.57	0.7	39.9	8.44	0.44	0.59	0.72

61.5 KW - STANDARD EFFICIENCY KGB210S4M (2ND STAGE) - MSAV® (MULTI-STAGE AIR VOLUME) SUPPLY AIR BLOWER

Entering Wet Bulb Temperature	Total Air Volume	Outdoor Air Temperature Entering Outdoor Coil																			
		26.7°C					35°C					43.3°C					46°C				
		Total Cool Cap.	Comp. Motor Input	Sensible To Total Ratio (S/T)			Total Cool Cap.	Comp. Motor Input	Sensible To Total Ratio (S/T)			Total Cool Cap.	Comp. Motor Input	Sensible To Total Ratio (S/T)			Total Cool Cap.	Comp. Motor Input	Sensible To Total Ratio (S/T)		
				Dry Bulb					Dry Bulb					Dry Bulb					Dry Bulb		
L/s	kW	kW	24°C	27°C	29°C	kW	kW	24°C	27°C	29°C	kW	kW	24°C	27°C	29°C	kW	kW	24°C	27°C	29°C	
17.2°C	1890	55.5	10.41	0.75	0.91	1.00	51.1	12.42	0.77	0.94	1.00	46.2	14.89	0.8	0.98	1.00	44.6	15.79	0.82	0.99	1.00
	2240	58.4	10.55	0.81	0.99	1.00	54	12.58	0.84	1.00	1.00	49.4	15.09	0.88	1.00	1.00	47.9	16.00	0.91	1.00	1.00
	2595	61.5	10.71	0.87	1.00	1.00	57	12.75	0.91	1.00	1.00	52.1	15.27	0.96	1.00	1.00	50.5	16.18	0.98	1.00	1.00
19.4°C	1890	59.1	10.58	0.58	0.72	0.87	54.4	12.6	0.59	0.75	0.9	49.2	15.08	0.6	0.77	0.95	47.4	15.97	0.61	0.80	0.97
	2240	61.8	10.72	0.61	0.79	0.96	56.8	12.75	0.63	0.81	0.99	51.3	15.2	0.65	0.85	1.00	49.5	16.09	0.67	0.88	1.00
	2595	63.7	10.83	0.66	0.85	1.00	58.5	12.85	0.68	0.89	1.00	53	15.31	0.70	0.94	1.00	51.1	16.21	0.73	0.96	1.00
21.7°C	1890	62.9	10.78	0.43	0.57	0.7	57.9	12.81	0.43	0.58	0.72	52.4	15.28	0.43	0.59	0.75	50.6	16.18	0.43	0.60	0.77
	2240	65.6	10.93	0.45	0.61	0.76	60.2	12.95	0.45	0.62	0.79	54.6	15.42	0.45	0.64	0.83	52.7	16.30	0.45	0.66	0.86
	2595	67.6	11.03	0.46	0.65	0.83	62.1	13.05	0.47	0.67	0.87	56.2	15.53	0.47	0.7	0.91	54.2	16.43	0.48	0.71	0.94

Entering Wet Bulb Temperature	Total Air Volume	Outdoor Air Temperature Entering Outdoor Coil																	
		48°C					50°C					51.7°C							
		Total Cool Cap.	Comp. Motor Input	Sensible To Total Ratio (S/T)			Total Cool Cap.	Comp. Motor Input	Sensible To Total Ratio (S/T)			Total Cool Cap.	Comp. Motor Input	Sensible To Total Ratio (S/T)					
				Dry Bulb					Dry Bulb					Dry Bulb					
L/s	kW	kW	24°C	27°C	29°C	kW	kW	24°C	27°C	29°C	kW	kW	24°C	27°C	29°C				
17.2°C	1890	43.4	16.52	0.83	1.00	1.00	42.2	17.29	0.84	1.00	1.00	41.3	17.99	0.84	1.00	1.00			
	2240	46.6	16.72	0.92	1.00	1.00	45.4	17.48	0.94	1.00	1.00	44.2	18.20	0.95	1.00	1.00			
	2595	49.2	16.89	0.99	1.00	1.00	47.9	17.68	0.99	1.00	1.00	46.7	18.38	1.00	1.00	1.00			
19.4°C	1890	46.0	16.69	0.62	0.81	0.98	44.7	17.44	0.62	0.82	0.99	43.3	18.12	0.62	0.81	0.99			
	2240	48.0	16.82	0.67	0.89	1.00	46.6	17.57	0.68	0.91	1.00	45.3	18.26	0.68	0.92	1.00			
	2595	49.7	16.93	0.73	0.97	1.00	48.2	17.67	0.74	0.98	1.00	46.8	18.38	0.74	0.99	1.00			
21.7°C	1890	49.1	16.89	0.43	0.61	0.78	47.7	17.63	0.43	0.61	0.79	46.4	18.34	0.43	0.61	0.79			
	2240	51.2	17.02	0.46	0.67	0.87	49.6	17.77	0.46	0.67	0.88	48.2	18.46	0.46	0.67	0.89			
	2595	52.7	17.13	0.48	0.73	0.95	51.1	17.90	0.49	0.74	0.97	49.6	18.57	0.49	0.73	0.97			

RATINGS - STANDARD EFFICIENCY

NOTE - For Temperatures and Capacities not shown in tables, see bulletin - Cooling Unit Rating Table Correction Factor Data in Miscellaneous Engineering Data section.

70.3 KW - STANDARD EFFICIENCY KGB240S4M (1ST STAGE) - MSAV® (MULTI-STAGE AIR VOLUME) SUPPLY AIR BLOWER

Entering Wet Bulb Temperature	Total Air Volume	Outdoor Air Temperature Entering Outdoor Coil																			
		18.3°C					23.9°C					29.4°C					35°C				
		Total Cool Cap.	Comp. Motor Input	Sensible To Total Ratio (S/T)			Total Cool Cap.	Comp. Motor Input	Sensible To Total Ratio (S/T)			Total Cool Cap.	Comp. Motor Input	Sensible To Total Ratio (S/T)			Total Cool Cap.	Comp. Motor Input	Sensible To Total Ratio (S/T)		
				Dry Bulb					Dry Bulb					Dry Bulb					Dry Bulb		
L/s	kW	kW	24°C	27°C	29°C	kW	kW	24°C	27°C	29°C	kW	kW	24°C	27°C	29°C	kW	kW	24°C	27°C	29°C	
17.2°C	2125	40.7	6.28	0.67	0.79	0.91	39.2	6.98	0.68	0.8	0.92	37.6	7.76	0.69	0.82	0.94	35.8	8.64	0.7	0.84	0.97
	2595	42.9	6.39	0.71	0.84	0.97	41.3	7.09	0.72	0.86	0.99	39.5	7.87	0.73	0.88	1.00	37.6	8.75	0.75	0.9	1.00
	3070	44.6	6.48	0.74	0.9	1.00	42.9	7.18	0.76	0.92	1.00	41.1	7.96	0.77	0.94	1.00	39.1	8.84	0.79	0.96	1.00
19.4°C	2125	43.4	6.42	0.54	0.65	0.75	41.8	7.12	0.55	0.66	0.77	40.1	7.9	0.55	0.66	0.78	38.2	8.79	0.56	0.68	0.8
	2595	45.7	6.54	0.56	0.68	0.81	44	7.24	0.57	0.69	0.82	42.1	8.02	0.57	0.7	0.84	40.1	8.89	0.58	0.72	0.86
	3070	47.4	6.63	0.58	0.72	0.86	45.7	7.32	0.59	0.73	0.88	43.7	8.1	0.6	0.75	0.9	41.6	8.98	0.61	0.77	0.93
21.7°C	2125	46.1	6.56	0.42	0.52	0.62	44.4	7.26	0.42	0.53	0.63	42.8	8.06	0.42	0.53	0.64	40.9	8.94	0.42	0.54	0.65
	2595	48.7	6.69	0.43	0.54	0.66	46.9	7.39	0.43	0.55	0.67	44.9	8.17	0.43	0.56	0.68	42.7	9.05	0.44	0.57	0.69
	3070	50.4	6.79	0.44	0.57	0.7	48.5	7.48	0.44	0.57	0.71	46.5	8.27	0.44	0.58	0.72	44.3	9.15	0.44	0.59	0.74

70.3 KW - STANDARD EFFICIENCY KGB240S4M (2ND STAGE) - MSAV® (MULTI-STAGE AIR VOLUME) SUPPLY AIR BLOWER

Entering Wet Bulb Temperature	Total Air Volume	Outdoor Air Temperature Entering Outdoor Coil																			
		26.7°C					35°C					43.3°C					46°C				
		Total Cool Cap.	Comp. Motor Input	Sensible To Total Ratio (S/T)			Total Cool Cap.	Comp. Motor Input	Sensible To Total Ratio (S/T)			Total Cool Cap.	Comp. Motor Input	Sensible To Total Ratio (S/T)			Total Cool Cap.	Comp. Motor Input	Sensible To Total Ratio (S/T)		
				Dry Bulb					Dry Bulb					Dry Bulb					Dry Bulb		
L/s	kW	kW	24°C	27°C	29°C	kW	kW	24°C	27°C	29°C	kW	kW	24°C	27°C	29°C	kW	kW	24°C	27°C	29°C	
17.2°C	3020	64.8	12.32	0.74	0.89	1.00	59.8	14.39	0.76	0.93	1.00	54.4	16.89	0.79	0.97	1.00	52.6	17.79	0.81	0.98	1.00
	3775	68.2	12.52	0.8	0.98	1.00	63.2	14.59	0.83	0.99	1.00	57.9	17.12	0.87	1.00	1.00	56.2	18.03	0.89	1.00	1.00
	4530	71.5	12.7	0.87	1.00	1.00	66.6	14.8	0.9	1.00	1.00	61	17.33	0.95	1.00	1.00	59.1	18.23	0.97	1.00	1.00
19.4°C	3020	68.9	12.56	0.58	0.71	0.86	63.7	14.62	0.59	0.74	0.89	57.9	17.12	0.6	0.77	0.94	55.9	18.01	0.61	0.79	0.95
	3775	72.1	12.74	0.62	0.78	0.95	66.4	14.79	0.63	0.81	0.98	60.3	17.28	0.65	0.84	1.00	58.2	18.17	0.66	0.87	1.00
	4530	74.3	12.87	0.65	0.84	1.00	68.5	14.92	0.67	0.88	1.00	62.4	17.42	0.69	0.93	1.00	60.2	18.30	0.71	0.95	1.00
21.7°C	3020	73.4	12.81	0.43	0.56	0.69	67.8	14.87	0.43	0.57	0.71	61.8	17.38	0.42	0.59	0.74	59.7	18.26	0.43	0.60	0.76
	3775	76.5	13	0.44	0.61	0.76	70.7	15.06	0.44	0.62	0.78	64.2	17.55	0.45	0.64	0.82	62.1	18.44	0.45	0.65	0.85
	4530	78.8	13.13	0.46	0.64	0.82	72.7	15.18	0.46	0.66	0.85	66	17.66	0.47	0.68	0.9	63.8	18.55	0.47	0.70	0.92
Entering Wet Bulb Temperature	Total Air Volume	Outdoor Air Temperature Entering Outdoor Coil																			
		48°C					50°C					51.7°C									
		Total Cool Cap.	Comp. Motor Input	Sensible To Total Ratio (S/T)			Total Cool Cap.	Comp. Motor Input	Sensible To Total Ratio (S/T)			Total Cool Cap.	Comp. Motor Input	Sensible To Total Ratio (S/T)							
				Dry Bulb					Dry Bulb					Dry Bulb							
L/s	kW	kW	24°C	27°C	29°C	kW	kW	24°C	27°C	29°C	kW	kW	24°C	27°C	29°C						
17.2°C	3020	51.3	18.51	0.82	0.99	1.00	49.9	19.27	0.83	0.99	1.00	48.7	19.96	0.83	1.00	1.00					
	3775	55.0	18.76	0.90	1.00	1.00	53.5	19.52	0.92	1.00	1.00	52.3	20.23	0.93	1.00	1.00					
	4530	57.8	18.96	0.98	1.00	1.00	56.3	19.73	0.98	1.00	1.00	55	20.41	0.99	1.00	1.00					
19.4°C	3020	54.4	18.72	0.61	0.80	0.97	52.8	19.47	0.62	0.81	0.98	51.4	20.14	0.62	0.8	0.98					
	3775	56.7	18.89	0.67	0.88	1.00	55.1	19.63	0.67	0.89	1.00	53.6	20.31	0.67	0.9	1.00					
	4530	58.5	19.02	0.72	0.96	1.00	56.9	19.77	0.73	0.97	1.00	55.4	20.44	0.73	0.98	1.00					
21.7°C	3020	58.1	18.99	0.43	0.61	0.77	56.5	19.74	0.43	0.61	0.78	55	20.4	0.43	0.61	0.78					
	3775	60.4	19.15	0.46	0.66	0.85	58.6	19.89	0.46	0.66	0.87	57.1	20.57	0.46	0.66	0.87					
	4530	62.0	19.26	0.48	0.71	0.94	60.2	20.00	0.49	0.72	0.95	58.7	20.71	0.48	0.72	0.96					

RATINGS - STANDARD EFFICIENCY

NOTE - For Temperatures and Capacities not shown in tables, see bulletin - Cooling Unit Rating Table Correction Factor Data in Miscellaneous Engineering Data section.

88 KW - STANDARD EFFICIENCY KGB300S4M (1ST STAGE) - MSAV® (MULTI-STAGE AIR VOLUME) SUPPLY AIR BLOWER

Entering Wet Bulb Temperature	Total Air Volume	Outdoor Air Temperature Entering Outdoor Coil																			
		18.3°C					23.9°C					29.4°C					35°C				
		Total Cool Cap.	Comp. Motor Input	Sensible To Total Ratio (S/T)			Total Cool Cap.	Comp. Motor Input	Sensible To Total Ratio (S/T)			Total Cool Cap.	Comp. Motor Input	Sensible To Total Ratio (S/T)			Total Cool Cap.	Comp. Motor Input	Sensible To Total Ratio (S/T)		
				Dry Bulb					Dry Bulb					Dry Bulb					Dry Bulb		
L/s	kW	kW	24°C	27°C	29°C	kW	kW	24°C	27°C	29°C	kW	kW	24°C	27°C	29°C	kW	kW	24°C	27°C	29°C	
17.2°C	2715	37.9	5.15	0.66	0.78	0.9	36.5	5.85	0.66	0.79	0.91	35	6.62	0.67	0.8	0.93	33.4	7.49	0.68	0.82	0.95
	3185	39.5	5.19	0.68	0.81	0.94	38	5.89	0.68	0.83	0.96	36.5	6.67	0.7	0.84	0.97	34.8	7.53	0.71	0.86	0.97
	3660	40.8	5.23	0.7	0.85	0.97	39.2	5.93	0.71	0.87	0.97	37.6	6.71	0.73	0.89	0.97	35.9	7.57	0.74	0.91	0.97
19.4°C	2715	40.3	5.22	0.52	0.63	0.74	38.7	5.92	0.52	0.63	0.75	37.3	6.7	0.53	0.65	0.76	35.5	7.56	0.52	0.65	0.78
	3185	41.9	5.26	0.53	0.66	0.78	40.3	5.97	0.53	0.66	0.79	38.6	6.74	0.53	0.67	0.8	36.8	7.61	0.54	0.68	0.82
	3660	43.2	5.3	0.53	0.68	0.81	41.6	6.01	0.55	0.69	0.83	39.7	6.78	0.56	0.7	0.85	38	7.66	0.56	0.71	0.87
21.7°C	2715	42.6	5.29	0.39	0.5	0.6	41.3	6	0.39	0.5	0.61	39.5	6.77	0.39	0.5	0.62	37.9	7.65	0.39	0.51	0.63
	3185	44.5	5.35	0.39	0.51	0.62	42.8	6.05	0.38	0.5	0.63	41	6.83	0.37	0.51	0.64	39.1	7.7	0.38	0.52	0.65
	3660	45.7	5.39	0.39	0.52	0.65	43.9	6.09	0.39	0.52	0.66	42.1	6.87	0.39	0.54	0.67	40.2	7.75	0.39	0.54	0.69

88 KW - STANDARD EFFICIENCY KGB300S4M (2ND STAGE) - MSAV® (MULTI-STAGE AIR VOLUME) SUPPLY AIR BLOWER

Entering Wet Bulb Temperature	Total Air Volume	Outdoor Air Temperature Entering Outdoor Coil																			
		26.7°C					35°C					43.3°C					46°C				
		Total Cool Cap.	Comp. Motor Input	Sensible To Total Ratio (S/T)			Total Cool Cap.	Comp. Motor Input	Sensible To Total Ratio (S/T)			Total Cool Cap.	Comp. Motor Input	Sensible To Total Ratio (S/T)			Total Cool Cap.	Comp. Motor Input	Sensible To Total Ratio (S/T)		
				Dry Bulb					Dry Bulb					Dry Bulb					Dry Bulb		
L/s	kW	kW	24°C	27°C	29°C	kW	kW	24°C	27°C	29°C	kW	kW	24°C	27°C	29°C	kW	kW	24°C	27°C	29°C	
17.2°C	3775	77.4	13.96	0.73	0.89	0.98	71.3	16.52	0.75	0.93	0.98	64.7	19.63	0.78	0.96	0.98	62.5	20.76	0.80	0.98	0.98
	4485	80.4	14.11	0.78	0.95	0.98	74.2	16.67	0.8	0.97	0.98	68.1	19.82	0.83	0.97	0.98	66.0	20.96	0.86	0.97	0.98
	5190	83.3	14.24	0.82	0.98	0.98	77.5	16.85	0.85	0.97	0.98	70.9	19.98	0.89	0.97	0.98	68.8	21.12	0.92	0.97	0.98
19.4°C	3775	82.3	14.19	0.56	0.71	0.85	75.8	16.75	0.57	0.73	0.89	68.8	19.87	0.58	0.75	0.93	66.4	20.98	0.59	0.78	0.95
	4485	85.2	14.33	0.59	0.75	0.92	78.3	16.9	0.6	0.78	0.95	71	19.99	0.61	0.81	0.97	68.6	21.11	0.62	0.83	0.97
	5190	87.3	14.45	0.61	0.8	0.97	80.4	17.01	0.63	0.83	0.97	72.9	20.1	0.64	0.87	0.97	70.4	21.22	0.65	0.89	0.97
21.7°C	3775	87.5	14.45	0.41	0.55	0.68	80.8	17.02	0.4	0.56	0.7	73.5	20.13	0.4	0.57	0.73	71.0	21.25	0.40	0.58	0.75
	4485	90.4	14.6	0.41	0.58	0.73	83.3	17.16	0.41	0.59	0.75	75.6	20.27	0.41	0.6	0.78	73.1	21.39	0.41	0.61	0.81
	5190	92.6	14.71	0.42	0.6	0.77	85.3	17.28	0.42	0.61	0.8	77.5	20.38	0.42	0.63	0.84	74.8	21.50	0.43	0.65	0.86

Entering Wet Bulb Temperature	Total Air Volume	Outdoor Air Temperature Entering Outdoor Coil																	
		48°C					50°C					51.7°C							
		Total Cool Cap.	Comp. Motor Input	Sensible To Total Ratio (S/T)			Total Cool Cap.	Comp. Motor Input	Sensible To Total Ratio (S/T)			Total Cool Cap.	Comp. Motor Input	Sensible To Total Ratio (S/T)					
				Dry Bulb					Dry Bulb					Dry Bulb					
L/s	kW	kW	24°C	27°C	29°C	kW	kW	24°C	27°C	29°C	kW	kW	24°C	27°C	29°C				
17.2°C	3775	60.9	21.67	0.81	0.98	0.98	59.3	22.64	0.82	0.98	0.98	58	23.5	0.82	0.97	0.98			
	4485	64.4	21.88	0.87	0.97	0.98	62.7	22.84	0.88	0.97	0.98	61.3	23.72	0.89	0.97	0.98			
	5190	67.0	22.04	0.93	0.97	0.98	65.3	22.99	0.94	0.97	0.98	63.8	23.88	0.94	0.97	0.97			
19.4°C	3775	64.6	21.89	0.59	0.78	0.96	62.7	22.84	0.60	0.79	0.97	61	23.7	0.59	0.79	0.97			
	4485	66.8	22.02	0.63	0.84	0.97	64.8	22.97	0.64	0.86	0.97	63	23.82	0.63	0.86	0.97			
	5190	68.5	22.12	0.66	0.90	0.97	66.6	23.08	0.67	0.91	0.97	64.8	23.94	0.67	0.92	0.96			
21.7°C	3775	69.0	22.14	0.40	0.58	0.76	67.0	23.09	0.40	0.59	0.77	65.3	23.96	0.39	0.58	0.76			
	4485	71.2	22.29	0.41	0.62	0.82	69.1	23.23	0.42	0.62	0.83	67.3	24.1	0.41	0.62	0.83			
	5190	72.7	22.39	0.43	0.65	0.87	70.7	23.34	0.42	0.66	0.89	68.8	24.2	0.42	0.66	0.89			

RATINGS - HIGH EFFICIENCY

NOTE - For Temperatures and Capacities not shown in tables, see bulletin - Cooling Unit Rating Table Correction Factor Data in Miscellaneous Engineering Data section.

45.7 kW - HIGH EFFICIENCY KGA156H4B (1ST STAGE) - CONSTANT AIR VOLUME

Entering Wet Bulb Temperature	Total Air Volume	Outdoor Air Temperature Entering Outdoor Coil																			
		18.3°C					23.9°C					29.4°C					35°C				
		Total Cool Cap.	Comp. Motor Input	Sensible To Total Ratio (S/T)			Total Cool Cap.	Comp. Motor Input	Sensible To Total Ratio (S/T)			Total Cool Cap.	Comp. Motor Input	Sensible To Total Ratio (S/T)			Total Cool Cap.	Comp. Motor Input	Sensible To Total Ratio (S/T)		
				Dry Bulb					Dry Bulb					Dry Bulb					Dry Bulb		
L/s	kW	kW	24°C	27°C	29°C	kW	kW	24°C	27°C	29°C	kW	kW	24°C	27°C	29°C	kW	kW	24°C	27°C	29°C	
17.2°C	1965	28.6	3.87	0.71	0.85	0.99	26.6	4.38	0.71	0.86	1.00	24.6	4.94	0.72	0.88	1.00	22.5	5.57	0.72	0.91	1.00
	2455	30.3	3.9	0.76	0.93	1.00	28.2	4.41	0.77	0.95	1.00	26.1	4.97	0.78	0.97	1.00	24.0	5.60	0.79	0.99	1.00
	2945	31.6	3.93	0.81	0.99	1.00	29.6	4.44	0.83	1.00	1.00	27.6	5.00	0.85	1.00	1.00	25.6	5.64	0.87	1.00	1.00
19.4°C	1965	30.7	3.91	0.56	0.68	0.81	28.7	4.42	0.55	0.69	0.83	26.6	4.98	0.54	0.69	0.84	24.4	5.61	0.54	0.70	0.87
	2455	32.4	3.95	0.59	0.74	0.90	30.3	4.45	0.59	0.75	0.92	28.1	5.01	0.59	0.76	0.94	25.9	5.64	0.59	0.77	0.96
	2945	33.8	3.98	0.62	0.79	0.97	31.5	4.48	0.62	0.81	0.99	29.2	5.04	0.63	0.82	0.99	26.9	5.67	0.63	0.85	1.00
21.7°C	1965	32.7	3.95	0.42	0.55	0.66	30.6	4.46	0.41	0.54	0.67	28.5	5.02	0.39	0.54	0.67	26.3	5.65	0.37	0.53	0.68
	2455	34.6	3.99	0.44	0.58	0.72	32.4	4.50	0.42	0.58	0.73	30.1	5.06	0.41	0.58	0.74	27.9	5.69	0.40	0.58	0.75
	2945	35.9	4.03	0.45	0.62	0.77	33.7	4.53	0.44	0.62	0.78	31.3	5.09	0.43	0.62	0.80	28.9	5.72	0.42	0.63	0.82

45.7 kW - HIGH EFFICIENCY KGA156H4B (2ND STAGE) - CONSTANT AIR VOLUME

Entering Wet Bulb Temperature	Total Air Volume	Outdoor Air Temperature Entering Outdoor Coil																			
		26.7°C					35°C					43.3°C					46°C				
		Total Cool Cap.	Comp. Motor Input	Sensible To Total Ratio (S/T)			Total Cool Cap.	Comp. Motor Input	Sensible To Total Ratio (S/T)			Total Cool Cap.	Comp. Motor Input	Sensible To Total Ratio (S/T)			Total Cool Cap.	Comp. Motor Input	Sensible To Total Ratio (S/T)		
				Dry Bulb					Dry Bulb					Dry Bulb					Dry Bulb		
L/s	kW	kW	24°C	27°C	29°C	kW	kW	24°C	27°C	29°C	kW	kW	24°C	27°C	29°C	kW	kW	24°C	27°C	29°C	
17.2°C	1965	39.3	7.04	0.74	0.91	1.00	34.6	8.43	0.76	0.95	1.00	29.7	10.11	0.78	0.99	1.00	28.2	10.73	.79	.99	1.00
	2455	41.6	7.09	0.81	0.99	1.00	37.1	8.48	0.83	1.00	1.00	32.4	10.18	0.87	1.00	1.00	30.9	10.79	.89	1.00	1.00
	2945	44.0	7.15	0.87	1.00	1.00	39.4	8.54	0.91	1.00	1.00	34.6	10.24	0.96	1.00	1.00	33.0	10.85	.97	1.00	1.00
19.4°C	1965	42.3	7.11	0.57	0.72	0.87	37.5	8.49	0.56	0.74	0.91	32.3	10.18	0.56	0.75	0.95	30.7	10.79	.55	.77	.97
	2455	44.6	7.16	0.61	0.79	0.96	39.5	8.54	0.61	0.81	0.99	34.1	10.23	0.61	0.85	1.00	32.4	10.83	.62	.87	1.00
	2945	46.2	7.2	0.65	0.85	1.00	40.9	8.58	0.66	0.89	1.00	35.4	10.26	0.67	0.93	1.00	33.6	10.87	.68	.95	1.00
21.7°C	1965	45.3	7.17	0.41	0.56	0.70	40.3	8.56	0.39	0.56	0.71	35.1	10.25	0.37	0.55	0.73	33.4	10.86	.35	.55	.75
	2455	47.7	7.23	0.43	0.60	0.77	42.5	8.62	0.41	0.61	0.79	37.0	10.30	0.39	0.61	0.82	35.2	10.91	.38	.62	.84
	2945	49.5	7.28	0.45	0.64	0.83	44.0	8.66	0.43	0.65	0.86	38.3	10.34	0.42	0.67	0.91	36.5	10.95	.41	.68	.93

Entering Wet Bulb Temperature	Total Air Volume	Outdoor Air Temperature Entering Outdoor Coil																	
		48°C					50°C					51.7°C							
		Total Cool Cap.	Comp. Motor Input	Sensible To Total Ratio (S/T)			Total Cool Cap.	Comp. Motor Input	Sensible To Total Ratio (S/T)			Total Cool Cap.	Comp. Motor Input	Sensible To Total Ratio (S/T)					
				Dry Bulb					Dry Bulb					Dry Bulb					
L/s	kW	kW	24°C	27°C	29°C	kW	kW	24°C	27°C	29°C	kW	kW	24°C	27°C	29°C				
17.2°C	1965	27.0	11.23	0.79	1.00	1.00	25.9	11.74	0.81	1.00	1.00	25.0	12.20	0.81	1.00	1.00			
	2455	29.7	11.30	0.90	1.00	1.00	28.5	11.81	0.92	1.00	1.00	27.5	12.27	0.93	1.00	1.00			
	2945	31.8	11.35	0.98	1.00	1.00	30.5	11.87	0.99	1.00	1.00	29.5	12.32	1.00	1.00	1.00			
19.4°C	1965	29.4	11.29	0.55	0.77	0.98	28.1	11.80	0.55	0.78	0.99	27.0	12.25	0.55	0.79	0.99			
	2455	31.0	11.33	0.62	0.87	1.00	29.7	11.84	0.62	0.89	1.00	28.5	12.30	0.62	0.90	1.00			
	2945	32.2	11.37	0.68	0.96	1.00	30.9	11.88	0.68	0.98	1.00	29.7	12.33	0.69	0.99	1.00			
21.7°C	1965	32.0	11.36	0.34	0.55	0.75	30.7	11.87	0.33	0.55	0.76	29.6	12.32	0.32	0.55	0.76			
	2455	33.8	11.41	0.38	0.62	0.85	32.4	11.92	0.37	0.62	0.86	31.2	12.37	0.36	0.62	0.87			
	2945	35.0	11.45	0.41	0.68	0.94	33.6	11.96	0.40	0.69	0.95	32.4	12.41	0.40	0.69	0.96			

RATINGS - HIGH EFFICIENCY

NOTE - For Temperatures and Capacities not shown in tables, see bulletin - Cooling Unit Rating Table Correction Factor Data in Miscellaneous Engineering Data section.

52.8 kW - HIGH EFFICIENCY KGA180H4B (1ST STAGE) - CONSTANT AIR VOLUME

Entering Wet Bulb Temperature	Total Air Volume	Outdoor Air Temperature Entering Outdoor Coil																			
		18.3°C					23.9°C					29.4°C					35°C				
		Total Cool Cap.	Comp. Motor Input	Sensible To Total Ratio (S/T)			Total Cool Cap.	Comp. Motor Input	Sensible To Total Ratio (S/T)			Total Cool Cap.	Comp. Motor Input	Sensible To Total Ratio (S/T)			Total Cool Cap.	Comp. Motor Input	Sensible To Total Ratio (S/T)		
				Dry Bulb					Dry Bulb					Dry Bulb					Dry Bulb		
L/s	kW	kW	24°C	27°C	29°C	kW	kW	24°C	27°C	29°C	kW	kW	24°C	27°C	29°C	kW	kW	24°C	27°C	29°C	
17.2°C	2265	33.1	4.13	0.73	0.86	0.98	31.1	4.77	0.73	0.87	0.99	28.9	5.46	0.74	0.89	1.00	26.7	6.22	0.75	0.90	1.00
	2830	35.1	4.14	0.78	0.93	1.00	32.9	4.78	0.79	0.94	1.00	30.6	5.48	0.80	0.96	1.00	28.3	6.25	0.81	0.98	1.00
	3400	36.5	4.14	0.83	0.98	1.00	34.3	4.79	0.84	1.00	1.00	32.1	5.49	0.85	1.00	1.00	29.9	6.26	0.87	1.00	1.00
19.4°C	2265	35.5	4.14	0.58	0.71	0.83	33.3	4.78	0.57	0.71	0.84	31.1	5.48	0.57	0.71	0.85	28.8	6.25	0.56	0.72	0.87
	2830	37.5	4.14	0.61	0.76	0.90	35.3	4.79	0.61	0.77	0.91	32.9	5.50	0.61	0.78	0.93	30.5	6.27	0.61	0.79	0.95
	3400	39.0	4.14	0.64	0.81	0.95	36.7	4.80	0.65	0.82	0.97	34.2	5.51	0.65	0.83	0.99	31.7	6.29	0.65	0.85	1.00
21.7°C	2265	37.7	4.14	0.44	0.57	0.69	35.5	4.79	0.43	0.56	0.69	33.3	5.50	0.41	0.56	0.69	30.9	6.28	0.40	0.55	0.70
	2830	39.9	4.15	0.45	0.60	0.74	37.6	4.81	0.44	0.60	0.75	35.1	5.52	0.43	0.60	0.76	32.6	6.30	0.42	0.60	0.77
	3400	41.4	4.15	0.46	0.63	0.79	39.0	4.81	0.45	0.64	0.80	36.5	5.53	0.45	0.64	0.81	33.9	6.31	0.44	0.64	0.83

52.8 kW - HIGH EFFICIENCY KGA180H4B (2ND STAGE) - CONSTANT AIR VOLUME

Entering Wet Bulb Temperature	Total Air Volume	Outdoor Air Temperature Entering Outdoor Coil																			
		26.7°C					35°C					43.3°C					46°C				
		Total Cool Cap.	Comp. Motor Input	Sensible To Total Ratio (S/T)			Total Cool Cap.	Comp. Motor Input	Sensible To Total Ratio (S/T)			Total Cool Cap.	Comp. Motor Input	Sensible To Total Ratio (S/T)			Total Cool Cap.	Comp. Motor Input	Sensible To Total Ratio (S/T)		
				Dry Bulb					Dry Bulb					Dry Bulb					Dry Bulb		
L/s	kW	kW	24°C	27°C	29°C	kW	kW	24°C	27°C	29°C	kW	kW	24°C	27°C	29°C	kW	kW	24°C	27°C	29°C	
17.2°C	2265	45.7	7.68	0.75	0.91	1.00	40.6	9.36	0.76	0.94	1.00	35.2	11.30	0.78	0.98	1.00	33.4	11.99	.79	.99	1.00
	2830	48.3	7.7	0.81	0.99	1.00	43.2	9.39	0.83	1.00	1.00	38.1	11.36	0.87	1.00	1.00	36.3	12.05	.89	1.00	1.00
	3400	50.8	7.72	0.87	1.00	1.00	45.8	9.43	0.90	1.00	1.00	40.4	11.41	0.95	1.00	1.00	38.6	12.10	.97	1.00	1.00
19.4°C	2265	49.1	7.71	0.57	0.73	0.87	43.9	9.40	0.57	0.74	0.91	38.1	11.36	0.57	0.76	0.95	36.2	12.04	.57	.77	.96
	2830	51.7	7.73	0.62	0.79	0.96	46.1	9.43	0.62	0.81	0.99	40.1	11.40	0.62	0.85	1.00	38.0	12.09	.63	.86	1.00
	3400	53.5	7.74	0.65	0.85	1.00	47.7	9.45	0.66	0.88	1.00	41.4	11.43	0.67	0.93	1.00	39.4	12.12	.68	.95	1.00
21.7°C	2265	52.4	7.73	0.42	0.56	0.70	47.0	9.44	0.40	0.56	0.72	41.1	11.42	0.38	0.56	0.74	39.1	12.11	.37	.57	.75
	2830	55.1	7.75	0.43	0.61	0.77	49.4	9.48	0.42	0.61	0.79	43.2	11.46	0.40	0.62	0.82	41.1	12.15	.40	.62	.84
	3400	57.0	7.77	0.45	0.65	0.83	51.0	9.50	0.44	0.66	0.86	44.6	11.49	0.43	0.68	0.91	42.4	12.18	.43	.68	.92

Entering Wet Bulb Temperature	Total Air Volume	Outdoor Air Temperature Entering Outdoor Coil																	
		48°C					50°C					51.7°C							
		Total Cool Cap.	Comp. Motor Input	Sensible To Total Ratio (S/T)			Total Cool Cap.	Comp. Motor Input	Sensible To Total Ratio (S/T)			Total Cool Cap.	Comp. Motor Input	Sensible To Total Ratio (S/T)					
				Dry Bulb					Dry Bulb					Dry Bulb					
L/s	kW	kW	24°C	27°C	29°C	kW	kW	24°C	27°C	29°C	kW	kW	24°C	27°C	29°C				
17.2°C	2265	32.1	12.53	0.80	1.00	1.00	30.7	13.09	0.81	1.00	1.00	29.6	13.58	0.82	1.00	1.00			
	2830	35.0	12.60	0.90	1.00	1.00	33.6	13.17	0.91	1.00	1.00	32.3	13.65	0.93	1.00	1.00			
	3400	37.1	12.65	0.98	1.00	1.00	35.7	13.21	0.99	1.00	1.00	34.4	13.70	1.00	1.00	1.00			
19.4°C	2265	34.7	12.60	0.57	0.78	0.98	33.1	13.15	0.57	0.79	0.99	31.9	13.64	0.57	0.80	1.00			
	2830	36.4	12.64	0.63	0.88	1.00	34.8	13.19	0.63	0.89	1.00	33.4	13.68	0.64	0.90	1.00			
	3400	37.7	12.67	0.69	0.96	1.00	36.1	13.23	0.69	0.98	1.00	34.7	13.72	0.70	0.99	1.00			
21.7°C	2265	37.6	12.66	0.36	0.57	0.76	35.9	13.22	0.35	0.57	0.77	34.6	13.71	0.34	0.57	0.78			
	2830	39.5	12.71	0.39	0.63	0.85	37.7	13.27	0.39	0.63	0.87	36.3	13.76	0.38	0.64	0.88			
	3400	40.7	12.74	0.42	0.69	0.94	38.9	13.30	0.42	0.70	0.95	37.5	13.79	0.42	0.71	0.97			

RATINGS - HIGH EFFICIENCY

NOTE - For Temperatures and Capacities not shown in tables, see bulletin - Cooling Unit Rating Table Correction Factor Data in Miscellaneous Engineering Data section.

61.5 kW - HIGH EFFICIENCY KGA210H4B (1ST STAGE) - CONSTANT AIR VOLUME

Entering Wet Bulb Temperature	Total Air Volume	Outdoor Air Temperature Entering Outdoor Coil																			
		18.3°C					23.9°C					29.4°C					35°C				
		Total Cool Cap.	Comp. Motor Input	Sensible To Total Ratio (S/T)			Total Cool Cap.	Comp. Motor Input	Sensible To Total Ratio (S/T)			Total Cool Cap.	Comp. Motor Input	Sensible To Total Ratio (S/T)			Total Cool Cap.	Comp. Motor Input	Sensible To Total Ratio (S/T)		
				Dry Bulb					Dry Bulb					Dry Bulb					Dry Bulb		
L/s	kW	kW	24°C	27°C	29°C	kW	kW	24°C	27°C	29°C	kW	kW	24°C	27°C	29°C	kW	kW	24°C	27°C	29°C	
17.2°C	2645	36.8	4.54	0.75	0.90	1.00	34.5	5.17	0.76	0.92	1.00	32.0	5.85	0.77	0.94	1.00	29.5	6.61	0.79	0.97	1.00
	3305	38.9	4.58	0.81	0.98	1.00	36.4	5.21	0.83	1.00	1.00	34.1	5.90	0.84	1.00	1.00	31.8	6.66	0.86	1.00	1.00
	3965	40.9	4.63	0.87	1.00	1.00	38.6	5.26	0.89	1.00	1.00	36.1	5.95	0.91	1.00	1.00	33.6	6.72	0.94	1.00	1.00
19.4°C	2645	39.4	4.6	0.59	0.73	0.87	37.0	5.23	0.59	0.74	0.89	34.5	5.91	0.59	0.75	0.91	31.9	6.67	0.59	0.76	0.93
	3305	41.4	4.64	0.63	0.79	0.95	38.8	5.27	0.63	0.81	0.97	36.1	5.95	0.62	0.82	0.99	33.3	6.71	0.64	0.84	1.00
	3965	42.8	4.67	0.66	0.85	1.00	40.1	5.30	0.67	0.87	1.00	37.3	5.98	0.67	0.89	1.00	34.5	6.74	0.68	0.92	1.00
21.7°C	2645	42.3	4.66	0.44	0.58	0.71	39.7	5.29	0.43	0.58	0.72	37.0	5.98	0.42	0.58	0.73	34.3	6.74	0.41	0.58	0.74
	3305	44.2	4.71	0.46	0.62	0.77	41.5	5.34	0.45	0.62	0.79	38.7	6.02	0.44	0.62	0.80	35.8	6.78	0.43	0.63	0.82
	3965	45.6	4.74	0.47	0.65	0.83	42.8	5.37	0.44	0.66	0.85	39.8	6.06	0.47	0.67	0.87	36.8	6.81	0.45	0.68	0.89

61.5 kW - HIGH EFFICIENCY KGA210H4B (2ND STAGE) - CONSTANT AIR VOLUME

Entering Wet Bulb Temperature	Total Air Volume	Outdoor Air Temperature Entering Outdoor Coil																			
		26.7°C					35°C					43.3°C					46°C				
		Total Cool Cap.	Comp. Motor Input	Sensible To Total Ratio (S/T)			Total Cool Cap.	Comp. Motor Input	Sensible To Total Ratio (S/T)			Total Cool Cap.	Comp. Motor Input	Sensible To Total Ratio (S/T)			Total Cool Cap.	Comp. Motor Input	Sensible To Total Ratio (S/T)		
				Dry Bulb					Dry Bulb					Dry Bulb					Dry Bulb		
L/s	kW	kW	24°C	27°C	29°C	kW	kW	24°C	27°C	29°C	kW	kW	24°C	27°C	29°C	kW	kW	24°C	27°C	29°C	
17.2°C	2645	52.3	8.76	0.76	0.92	1.00	46.7	10.53	0.77	0.95	1.00	40.8	12.65	0.80	0.99	1.00	38.9	13.41	0.81	0.99	1.00
	3305	55.5	8.83	0.82	0.99	1.00	49.9	10.61	0.85	1.00	1.00	44.2	12.74	0.89	1.00	1.00	42.3	13.50	0.91	1.00	1.00
	3965	58.6	8.91	0.88	1.00	1.00	52.9	10.69	0.92	1.00	1.00	46.9	12.81	0.97	1.00	1.00	44.8	13.57	0.98	1.00	1.00
19.4°C	2645	56.3	8.85	0.58	0.73	0.88	50.3	10.62	0.58	0.75	0.92	43.9	12.73	0.58	0.77	0.96	41.9	13.49	0.59	0.79	0.98
	3305	59.1	8.92	0.62	0.80	0.97	52.7	10.68	0.63	0.82	0.99	46.1	12.79	0.64	0.86	1.00	44.0	13.54	0.64	0.89	1.00
	3965	61.1	8.97	0.65	0.87	1.00	54.5	10.73	0.67	0.90	1.00	47.8	12.84	0.69	0.95	1.00	45.4	13.59	0.70	0.96	1.00
21.7°C	2645	60.4	8.95	0.42	0.57	0.71	54.2	10.72	0.41	0.57	0.73	47.5	12.83	0.39	0.57	0.75	45.3	13.58	0.38	0.58	0.77
	3305	63.2	9.02	0.44	0.61	0.78	56.6	10.79	0.43	0.62	0.81	49.6	12.89	0.41	0.63	0.84	47.4	13.64	0.41	0.64	0.86
	3965	65.1	9.07	0.46	0.65	0.85	58.4	10.84	0.44	0.67	0.88	51.3	12.94	0.45	0.69	0.93	48.9	13.69	0.44	0.70	0.95

Entering Wet Bulb Temperature	Total Air Volume	Outdoor Air Temperature Entering Outdoor Coil																	
		48°C					50°C					51.7°C							
		Total Cool Cap.	Comp. Motor Input	Sensible To Total Ratio (S/T)			Total Cool Cap.	Comp. Motor Input	Sensible To Total Ratio (S/T)			Total Cool Cap.	Comp. Motor Input	Sensible To Total Ratio (S/T)					
				Dry Bulb					Dry Bulb					Dry Bulb					
L/s	kW	kW	24°C	27°C	29°C	kW	kW	24°C	27°C	29°C	kW	kW	24°C	27°C	29°C				
17.2°C	2645	37.5	14.03	0.82	1.00	1.00	36.0	14.66	0.83	1.00	1.00	34.8	15.21	0.84	1.00	1.00			
	3305	40.7	14.11	0.92	1.00	1.00	39.2	14.73	0.94	1.00	1.00	38.0	15.29	0.95	1.00	1.00			
	3965	43.2	14.18	0.99	1.00	1.00	41.6	14.80	0.99	1.00	1.00	40.2	15.35	0.99	1.00	1.00			
19.4°C	2645	40.2	14.10	0.58	0.79	0.98	38.4	14.72	0.58	0.81	0.99	37.0	15.26	0.58	0.82	0.99			
	3305	42.1	14.15	0.64	0.90	1.00	40.4	14.77	0.65	0.91	1.00	39.0	15.32	0.65	0.93	1.00			
	3965	43.7	14.19	0.71	0.98	1.00	42.0	14.81	0.72	0.98	1.00	40.5	15.36	0.73	0.99	1.00			
21.7°C	2645	43.6	14.19	0.38	0.58	0.77	41.9	14.81	0.37	0.58	0.78	40.3	15.34	0.37	0.58	0.79			
	3305	45.5	14.25	0.41	0.64	0.87	43.7	14.86	0.41	0.65	0.89	42.2	15.40	0.40	0.66	0.90			
	3965	47.0	14.28	0.45	0.71	0.96	45.1	14.90	0.44	0.72	0.97	43.5	15.45	0.44	0.73	0.98			

RATINGS - HIGH EFFICIENCY

NOTE - For Temperatures and Capacities not shown in tables, see bulletin - Cooling Unit Rating Table Correction Factor Data in Miscellaneous Engineering Data section.

70.3 kW - HIGH EFFICIENCY KGA240H4B (1ST STAGE) - CONSTANT AIR VOLUME

Entering Wet Bulb Temperature	Total Air Volume	Outdoor Air Temperature Entering Outdoor Coil																			
		18.3°C					23.9°C					29.4°C					35°C				
		Total Cool Cap.	Comp. Motor Input	Sensible To Total Ratio (S/T)			Total Cool Cap.	Comp. Motor Input	Sensible To Total Ratio (S/T)			Total Cool Cap.	Comp. Motor Input	Sensible To Total Ratio (S/T)			Total Cool Cap.	Comp. Motor Input	Sensible To Total Ratio (S/T)		
				Dry Bulb					Dry Bulb					Dry Bulb					Dry Bulb		
L/s	kW	kW	24°C	27°C	29°C	kW	kW	24°C	27°C	29°C	kW	kW	24°C	27°C	29°C	kW	kW	24°C	27°C	29°C	
17.2°C	3020	33.6	4.26	0.72	0.86	0.99	31.7	4.85	0.73	0.88	1.00	29.9	5.50	0.74	0.90	1.00	27.9	6.23	0.75	0.93	1.00
	3775	35.4	4.3	0.77	0.94	1.00	33.5	4.90	0.79	0.97	1.00	31.6	5.55	0.80	0.98	1.00	29.6	6.27	0.82	0.99	1.00
	4530	37.0	4.34	0.83	0.99	1.00	35.0	4.94	0.85	1.00	1.00	33.1	5.59	0.86	1.00	1.00	31.2	6.32	0.90	1.00	1.00
19.4°C	3020	35.9	4.31	0.57	0.70	0.83	34.0	4.91	0.57	0.70	0.84	32.0	5.56	0.57	0.72	0.86	29.9	6.28	0.57	0.73	0.89
	3775	37.6	4.35	0.60	0.75	0.91	35.5	4.95	0.61	0.77	0.93	33.4	5.60	0.61	0.78	0.96	31.2	6.32	0.61	0.80	0.98
	4530	38.9	4.39	0.64	0.81	0.98	36.7	4.98	0.63	0.82	0.99	34.5	5.63	0.65	0.84	1.00	32.2	6.36	0.66	0.87	1.00
21.7°C	3020	38.2	4.37	0.43	0.55	0.67	36.3	4.97	0.42	0.56	0.68	34.1	5.62	0.42	0.56	0.70	31.9	6.35	0.41	0.56	0.71
	3775	40.0	4.42	0.44	0.59	0.73	37.9	5.02	0.44	0.60	0.75	35.7	5.67	0.44	0.61	0.76	33.3	6.39	0.43	0.61	0.78
	4530	41.3	4.45	0.46	0.63	0.79	39.0	5.05	0.46	0.63	0.80	36.7	5.70	0.45	0.64	0.82	34.2	6.42	0.46	0.65	0.85

70.3 kW - HIGH EFFICIENCY KGA240H4B (2ND STAGE) - CONSTANT AIR VOLUME

Entering Wet Bulb Temperature	Total Air Volume	Outdoor Air Temperature Entering Outdoor Coil																			
		26.7°C					35°C					43.3°C					46°C				
		Total Cool Cap.	Comp. Motor Input	Sensible To Total Ratio (S/T)			Total Cool Cap.	Comp. Motor Input	Sensible To Total Ratio (S/T)			Total Cool Cap.	Comp. Motor Input	Sensible To Total Ratio (S/T)			Total Cool Cap.	Comp. Motor Input	Sensible To Total Ratio (S/T)		
				Dry Bulb					Dry Bulb					Dry Bulb					Dry Bulb		
L/s	kW	kW	24°C	27°C	29°C	kW	kW	24°C	27°C	29°C	kW	kW	24°C	27°C	29°C	kW	kW	24°C	27°C	29°C	
17.2°C	3020	62.5	10.37	0.77	0.94	1.00	56.6	12.48	0.79	0.97	1.00	50.5	15.05	0.82	0.99	1.00	48.4	15.98	.85	1.00	1.00
	3775	66.0	10.47	0.83	1.00	1.00	60.1	12.59	0.87	1.00	1.00	53.9	15.17	0.92	1.00	1.00	51.8	16.10	.94	1.00	1.00
	4530	69.3	10.57	0.90	1.00	1.00	63.2	12.69	0.94	1.00	1.00	56.5	15.26	0.98	1.00	1.00	54.4	16.19	.99	1.00	1.00
19.4°C	3020	66.6	10.48	0.59	0.74	0.90	60.2	12.59	0.60	0.77	0.94	53.3	15.15	0.61	0.80	0.98	51.0	16.07	.62	.83	.99
	3775	69.4	10.57	0.63	0.81	0.98	62.7	12.67	0.64	0.84	1.00	55.5	15.23	0.66	0.89	1.00	53.1	16.14	.68	.92	1.00
	4530	71.5	10.64	0.67	0.88	1.00	64.5	12.74	0.69	0.92	1.00	57.3	15.29	0.71	0.97	1.00	54.7	16.20	.74	.98	1.00
21.7°C	3020	71.0	10.62	0.43	0.58	0.72	64.4	12.73	0.42	0.59	0.75	57.1	15.28	0.41	0.60	0.78	54.7	16.20	.42	.61	.81
	3775	73.8	10.71	0.45	0.63	0.79	66.7	12.81	0.45	0.64	0.82	59.1	15.36	0.44	0.66	0.87	56.6	16.27	.44	.67	.90
	4530	75.7	10.77	0.47	0.66	0.86	68.4	12.87	0.47	0.69	0.90	60.6	15.41	0.47	0.71	0.96	58.0	16.33	.48	.74	.97

Entering Wet Bulb Temperature	Total Air Volume	Outdoor Air Temperature Entering Outdoor Coil																	
		48°C					50°C					51.7°C							
		Total Cool Cap.	Comp. Motor Input	Sensible To Total Ratio (S/T)			Total Cool Cap.	Comp. Motor Input	Sensible To Total Ratio (S/T)			Total Cool Cap.	Comp. Motor Input	Sensible To Total Ratio (S/T)					
				Dry Bulb					Dry Bulb					Dry Bulb					
L/s	kW	kW	24°C	27°C	29°C	kW	kW	24°C	27°C	29°C	kW	kW	24°C	27°C	29°C				
17.2°C	3020	46.9	16.74	0.84	1.00	1.00	45.3	17.52	0.86	1.00	1.00	44.0	18.21	0.88	1.00	1.00			
	3775	50.2	16.85	0.95	1.00	1.00	48.5	17.62	0.96	1.00	1.00	47.1	18.31	0.97	1.00	1.00			
	4530	52.7	16.94	1.00	1.00	1.00	50.9	17.72	1.00	1.00	1.00	49.4	18.39	1.00	1.00	1.00			
19.4°C	3020	49.1	16.82	0.61	0.82	0.99	47.4	17.59	0.62	0.84	1.00	45.9	18.27	0.62	0.85	1.00			
	3775	51.3	16.90	0.67	0.93	1.00	49.4	17.66	0.68	0.94	1.00	47.7	18.34	0.69	0.96	1.00			
	4530	53.0	16.95	0.74	0.99	1.00	51.1	17.72	0.75	0.99	1.00	49.5	18.41	0.76	1.00	1.00			
21.7°C	3020	52.8	16.94	0.41	0.61	0.80	50.8	17.71	0.41	0.61	0.81	49.2	18.39	0.41	0.62	0.83			
	3775	54.6	17.01	0.44	0.67	0.90	52.6	17.77	0.44	0.68	0.92	50.9	18.45	0.44	0.69	0.94			
	4530	56.0	17.07	0.47	0.74	0.98	53.9	17.83	0.47	0.75	0.99	52.2	18.50	0.47	0.76	0.99			

BLOWER DATA

BLOWER TABLE INCLUDES RESISTANCE FOR BASE UNIT ONLY WITH DRY INDOOR COIL & AIR FILTERS IN PLACE FOR ALL UNITS ADD:

- 1 - Wet indoor coil air resistance of selected unit.
- 2 - Any factory installed options air resistance (electric heat, economizer, etc.)
- 3 - Any field installed accessories air resistance (electric heat, duct resistance, diffuser, etc.)

Then determine from blower table blower motor output and drive required.

See page 33 for wet coil and option/accessory air resistance data.

See page 33 for factory installed drive kit specifications.

Air Volume		TOTAL STATIC PRESSURE - Pa (Inches Water Gauge)																	
		100 (0.40)			150 (0.60)			200 (0.80)			250 (1.00)			300 (1.20)			350 (1.40)		
L/s	cfm	rev/min	kW	BHP	rev/min	kW	BHP	rev/min	kW	BHP	rev/min	kW	BHP	rev/min	kW	BHP	rev/min	kW	BHP
1890	4000	545	0.63	0.85	635	0.82	1.10	715	1.04	1.40	785	1.27	1.70	850	1.49	2.00	910	1.72	2.30
2005	4250	555	0.67	0.90	645	0.93	1.25	725	1.16	1.55	795	1.38	1.85	855	1.60	2.15	915	1.83	2.45
2125	4500	565	0.75	1.00	655	1.01	1.35	730	1.23	1.65	800	1.49	2.00	865	1.75	2.35	925	1.98	2.65
2240	4750	575	0.82	1.10	660	1.08	1.45	740	1.34	1.80	810	1.60	2.15	870	1.86	2.50	930	2.13	2.85
2360	5000	585	0.93	1.25	670	1.19	1.60	750	1.45	1.95	815	1.72	2.30	880	2.01	2.70	940	2.27	3.05
2480	5250	595	1.01	1.35	680	1.27	1.70	755	1.57	2.10	825	1.86	2.50	890	2.16	2.90	945	2.42	3.25
2595	5500	605	1.08	1.45	690	1.38	1.85	765	1.68	2.25	835	1.98	2.65	895	2.27	3.05	955	2.57	3.45
2715	5750	615	1.19	1.60	700	1.49	2.00	775	1.83	2.45	840	2.13	2.85	905	2.42	3.25	960	2.72	3.65
2830	6000	630	1.30	1.75	710	1.60	2.15	785	1.94	2.60	850	2.27	3.05	910	2.57	3.45	970	2.91	3.90
2950	6250	640	1.42	1.90	720	1.75	2.35	795	2.09	2.80	860	2.42	3.25	920	2.76	3.70	975	3.09	4.15
3070	6500	650	1.53	2.05	730	1.86	2.50	805	2.24	3.00	870	2.57	3.45	930	2.95	3.95	985	3.28	4.40
3185	6750	665	1.64	2.20	745	2.01	2.70	815	2.39	3.20	880	2.76	3.70	940	3.13	4.20	995	3.47	4.65
3305	7000	675	1.75	2.35	755	2.16	2.90	825	2.54	3.40	890	2.95	3.95	950	3.32	4.45	1005	3.69	4.95
3420	7250	690	1.94	2.60	765	2.31	3.10	835	2.72	3.65	900	3.09	4.15	955	3.47	4.65	1015	3.91	5.25
3540	7500	700	2.05	2.75	775	2.46	3.30	845	2.87	3.85	910	3.32	4.45	965	3.69	4.95	1020	4.10	5.50
3660	7750	715	2.24	3.00	790	2.65	3.55	855	3.06	4.10	920	3.50	4.70	975	3.91	5.25	1030	4.33	5.80
3775	8000	725	2.39	3.20	800	2.83	3.80	865	3.24	4.35	930	3.69	4.95	985	4.10	5.50	1040	4.55	6.10
3895	8250	740	2.54	3.40	810	2.98	4.00	880	3.47	4.65	940	3.91	5.25	995	4.36	5.85	1050	4.81	6.45
4010	8500	750	2.72	3.65	825	3.21	4.30	890	3.65	4.90	950	4.14	5.55	1005	4.59	6.15	1060	5.07	6.80
4130	8750	765	2.91	3.90	835	3.39	4.55	900	3.88	5.20	960	4.36	5.85	1015	4.81	6.45	1070	5.33	7.15
4250	9000	780	3.13	4.20	850	3.62	4.85	910	4.10	5.50	970	4.59	6.15	1025	5.07	6.80	1080	5.59	7.50
4365	9250	790	3.32	4.45	860	3.84	5.15	925	4.36	5.85	985	4.88	6.55	1040	5.37	7.20	1090	5.85	7.85
4485	9500	805	3.54	4.75	875	4.06	5.45	935	4.59	6.15	995	5.15	6.90	1050	5.67	7.60	1100	6.15	8.25
4600	9750	820	3.77	5.05	885	4.29	5.75	950	4.88	6.55	1005	5.37	7.20	1060	5.93	7.95	1110	6.45	8.65
4720	10,000	835	4.03	5.40	900	4.59	6.15	960	5.11	6.85	1015	5.67	7.60	1070	6.23	8.35	1120	6.75	9.05
4835	10,250	845	4.21	5.65	910	4.81	6.45	970	5.37	7.20	1030	5.97	8.00	1080	6.52	8.75	1135	7.12	9.55
4955	10,500	860	4.47	6.00	925	5.11	6.85	985	5.70	7.65	1040	6.26	8.40	1095	6.86	9.20	1145	7.46	10.00
5075	10,750	875	4.77	6.40	940	5.41	7.25	1000	6.00	8.05	1055	6.60	8.85	1105	7.20	9.65	1155	7.79	10.45
5190	11,000	890	5.07	6.80	950	5.67	7.60	1010	6.30	8.45	1065	6.94	9.30	1115	7.49	10.05	1165	8.13	10.90

CONTINUED ON NEXT PAGE

BLOWER DATA

BLOWER TABLE INCLUDES RESISTANCE FOR BASE UNIT ONLY WITH DRY INDOOR COIL & AIR FILTERS IN PLACE FOR ALL UNITS ADD:

- 1 - Wet indoor coil air resistance of selected unit.
- 2 - Any factory installed options air resistance (electric heat, economizer, etc.)
- 3 - Any field installed accessories air resistance (electric heat, duct resistance, diffuser, etc.)

Then determine from blower table blower motor output and drive required.

See page 33 for wet coil and option/accessory air resistance data.

See page 33 for factory installed drive kit specifications.

Air Volume		TOTAL STATIC PRESSURE - Pa (Inches Water Gauge)																	
		400 (1.60)			450 (1.80)			500 (2.00)			550 (2.20)			600 (2.40)			650 (2.60)		
L/s	cfm	rev/min	kW	BHP	rev/min	kW	BHP	rev/min	kW	BHP	rev/min	kW	BHP	rev/min	kW	BHP	rev/min	kW	BHP
1890	4000	965	1.94	2.60	1020	2.16	2.90	1070	2.42	3.25	1115	2.65	3.55	1160	2.87	3.85	1205	3.09	4.15
2005	4250	970	2.09	2.80	1025	2.31	3.10	1075	2.57	3.45	1120	2.80	3.75	1165	3.06	4.10	1210	3.32	4.45
2125	4500	980	2.24	3.00	1030	2.46	3.30	1080	2.72	3.65	1130	3.02	4.05	1175	3.24	4.35	1215	3.50	4.70
2240	4750	985	2.39	3.20	1040	2.65	3.55	1085	2.91	3.90	1135	3.17	4.25	1180	3.47	4.65	1225	3.73	5.00
2360	5000	995	2.54	3.40	1045	2.83	3.80	1095	3.09	4.15	1140	3.36	4.50	1185	3.65	4.90	1230	3.95	5.30
2480	5250	1000	2.72	3.65	1050	2.98	4.00	1100	3.28	4.40	1150	3.58	4.80	1195	3.88	5.20	1235	4.18	5.60
2595	5500	1010	2.87	3.85	1060	3.17	4.25	1110	3.50	4.70	1155	3.80	5.10	1200	4.10	5.50	1240	4.40	5.90
2715	5750	1015	3.06	4.10	1065	3.36	4.50	1115	3.69	4.95	1160	3.99	5.35	1205	4.33	5.80	1250	4.66	6.25
2830	6000	1025	3.24	4.35	1075	3.58	4.80	1120	3.88	5.20	1170	4.21	5.65	1215	4.55	6.10	1255	4.88	6.55
2950	6250	1030	3.43	4.60	1080	3.77	5.05	1130	4.10	5.50	1175	4.44	5.95	1220	4.81	6.45	1265	5.15	6.90
3070	6500	1040	3.62	4.85	1090	3.99	5.35	1140	4.36	5.85	1185	4.70	6.30	1225	5.03	6.75	1270	5.41	7.25
3185	6750	1045	3.80	5.10	1095	4.18	5.60	1145	4.55	6.10	1190	4.92	6.60	1235	5.29	7.10	1275	5.67	7.60
3305	7000	1055	4.03	5.40	1105	4.44	5.95	1155	4.81	6.45	1200	5.18	6.95	1240	5.56	7.45	1285	5.97	8.00
3420	7250	1065	4.29	5.75	1115	4.66	6.25	1160	5.03	6.75	1205	5.44	7.30	1250	5.85	7.85	1290	6.23	8.35
3540	7500	1075	4.51	6.05	1125	4.92	6.60	1170	5.33	7.15	1215	5.70	7.65	1260	6.15	8.25	1300	6.52	8.75
3660	7750	1080	4.74	6.35	1130	5.15	6.90	1180	5.59	7.50	1225	6.00	8.05	1265	6.41	8.60	1305	6.82	9.15
3775	8000	1090	5.00	6.70	1140	5.41	7.25	1185	5.85	7.85	1230	6.26	8.40	1275	6.71	9.00	1315	7.16	9.60
3895	8250	1100	5.26	7.05	1150	5.70	7.65	1195	6.15	8.25	1240	6.60	8.85	1280	7.01	9.40	1325	7.49	10.05
4010	8500	1110	5.52	7.40	1160	6.00	8.05	1205	6.45	8.65	1250	6.90	9.25	1290	7.35	9.85	1330	7.79	10.45
4130	8750	1120	5.78	7.75	1165	6.23	8.35	1215	6.75	9.05	1255	7.20	9.65	1300	7.68	10.30	1340	8.13	10.90
4250	9000	1130	6.08	8.15	1175	6.52	8.75	1220	7.01	9.40	1265	7.53	10.10	1310	8.05	10.80	1350	8.50	11.40
4365	9250	1140	6.38	8.55	1185	6.86	9.20	1230	7.35	9.85	1275	7.87	10.55	1315	8.35	11.20	---	---	---
4485	9500	1150	6.67	8.95	1195	7.16	9.60	1240	7.68	10.30	1285	8.24	11.05	---	---	---	---	---	---
4600	9750	1160	7.01	9.40	1205	7.49	10.05	1250	8.05	10.80	1295	8.58	11.50	---	---	---	---	---	---
4720	10 000	1170	7.31	9.80	1215	7.83	10.50	1260	8.39	11.25	---	---	---	---	---	---	---	---	---
4835	10 250	1180	7.64	10.25	1225	8.20	11.00	---	---	---	---	---	---	---	---	---	---	---	---
4955	10 500	1190	7.98	10.70	1235	8.54	11.45	---	---	---	---	---	---	---	---	---	---	---	---
5075	10 750	1200	8.35	11.20	---	---	---	---	---	---	---	---	---	---	---	---	---	---	---
5190	11 000	---	---	---	---	---	---	---	---	---	---	---	---	---	---	---	---	---	---

BLOWER DATA

FACTORY INSTALLED BELT DRIVE KIT SPECIFICATIONS

Motor Efficiency	Nominal kW	Nominal hp		Maximum kW		Maximum hp		Drive Kit Number	Rev/Min Range	
									CAV	MSAV
Standard	1.5	2		1.7		2.3		1	446 - 604	535-725
Standard	1.5	2		1.7		2.3		2	592 - 804	710-965
Standard	2.2	3		2.6		3.5		3	571 - 721	685-865
Standard	2.2	3		2.6		3.5		4	708 - 871	850-1045
Standard	3.7	5		4.3		5.8		3	571 - 721	685-865
Standard	3.7	5		4.3		5.8		4	708 - 871	850-1045
Standard	3.7	5		4.3		5.8		5	788 - 988	945-1185
Standard	5.6	8		6.4		8.6		6	708 - 871	850-1045
Standard	5.6	8		6.4		8.6		7	788 - 988	945-1185
Standard	5.6	8		6.4		8.6		8	871 - 1071	1045-1285
Standard	7.5	10		8.6		11.5		7	788 - 988	945-1185
Standard	7.5	10		8.6		11.5		10	871 - 1071	1045-1285
Standard	7.5	10		8.6		11.5		11	946 - 1138	1135-1365

NOTE - Using total air volume and system static pressure requirements determine from blower performance tables rev/min and motor output required. Maximum usable output of motors furnished are shown. If motors of comparable output are used, be sure to keep within the service factor limitations outlined on the motor nameplate.

NOTE - Units equipped with MSAV® (Multi-Stage Air Volume) option are limited to a motor service factor of 1.0.

FACTORY INSTALLED OPTIONS/FIELD INSTALLED ACCESSORY AIR RESISTANCE

Air Volume		Wet Indoor Coil				Gas Heat Exchanger						Filters				Horizontal Roof Curb					
		156H 180H 180S		210H 210S 240H 240S 300S		Standard Heat		Medium Heat		High Heat		Economizer		MERV 8		MERV 13		156H 180S 240H 240S		300S	
L/s	cfm	Pa	in. w.g.	Pa	in. w.g.	Pa	in. w.g.	Pa	in. w.g.	Pa	in. w.g.	Pa	in. w.g.	Pa	in. w.g.	Pa	in. w.g.	Pa	in. w.g.	Pa	in. w.g.
1888	4000	5	0.02	10	0.04	10	0.04	15	0.06	17	0.07	---	---	3	0.01	11	0.04	15	0.06	5	0.02
2006	4250	5	0.02	10	0.04	10	0.04	15	0.06	20	0.08	---	---	3	0.01	12	0.05	17	0.07	5	0.02
2124	4500	5	0.02	12	0.05	12	0.05	17	0.07	22	0.09	---	---	4	0.01	12	0.05	17	0.07	5	0.02
2242	4750	5	0.02	12	0.05	12	0.05	20	0.08	25	0.10	---	---	4	0.02	13	0.05	20	0.08	7	0.03
2360	5000	5	0.02	12	0.05	12	0.05	22	0.09	27	0.11	---	---	5	0.02	14	0.06	20	0.08	7	0.03
2477	5250	5	0.02	15	0.06	15	0.06	25	0.10	30	0.12	---	---	5	0.02	15	0.06	22	0.09	10	0.04
2595	5500	5	0.02	17	0.07	15	0.06	25	0.10	32	0.13	---	---	6	0.02	15	0.06	25	0.10	10	0.04
2713	5750	7	0.03	17	0.07	15	0.06	27	0.11	35	0.14	---	---	6	0.02	16	0.07	27	0.11	12	0.05
2831	6000	7	0.03	20	0.08	17	0.07	30	0.12	37	0.15	---	---	7	0.03	17	0.07	27	0.11	15	0.06
2949	6250	7	0.03	20	0.08	17	0.07	30	0.12	40	0.16	2	0.01	7	0.03	18	0.07	30	0.12	17	0.07
3067	6500	7	0.03	22	0.09	20	0.08	32	0.13	42	0.17	5	0.02	8	0.03	19	0.08	32	0.13	20	0.08
3185	6750	10	0.04	25	0.10	20	0.08	35	0.14	45	0.18	7	0.03	8	0.03	20	0.08	35	0.14	20	0.08
3303	7000	10	0.04	25	0.10	22	0.09	37	0.15	47	0.19	10	0.04	9	0.04	20	0.08	37	0.15	22	0.09
3421	7250	10	0.04	27	0.11	22	0.09	40	0.16	50	0.20	12	0.05	10	0.04	21	0.09	40	0.16	25	0.10
3539	7500	12	0.05	30	0.12	25	0.10	42	0.17	52	0.21	15	0.06	10	0.04	22	0.09	42	0.17	27	0.11
3775	8000	12	0.05	32	0.13	27	0.11	47	0.19	60	0.24	22	0.09	12	0.05	24	0.10	47	0.19	32	0.13
4011	8500	15	0.06	37	0.15	30	0.12	50	0.20	65	0.26	27	0.11	13	0.05	25	0.10	52	0.21	37	0.15
4247	9000	17	0.07	40	0.16	32	0.13	57	0.23	72	0.29	35	0.14	15	0.06	27	0.11	60	0.24	42	0.17
4483	9500	20	0.08	45	0.18	35	0.14	62	0.25	80	0.32	40	0.16	17	0.07	29	0.12	65	0.26	47	0.19
4719	10 000	20	0.08	50	0.20	40	0.16	67	0.27	87	0.35	47	0.19	19	0.07	31	0.12	72	0.29	52	0.21
4955	10 500	22	0.09	55	0.22	42	0.17	75	0.30	94	0.38	55	0.22	20	0.08	33	0.13	77	0.31	60	0.24
5191	11 000	27	0.11	60	0.24	45	0.18	77	0.31	99	0.40	62	0.25	22	0.09	35	0.14	85	0.34	67	0.27

BLOWER DATA

POWER EXHAUST FAN PERFORMANCE

Return Air System Static Pressure		Air Volume Exhausted	
Pa	in. w.g.	L/s	cfm
0	0.00	3395	7195
12	0.05	3230	6845
25	0.10	3040	6440
37	0.15	2795	5925
50	0.20	2545	5395
62	0.25	2275	4820
75	0.30	1990	4215
87	0.35	1690	3580
100	0.40	1380	2925
112	0.45	1055	2235
125	0.50	725	1535

CEILING DIFFUSER AIR RESISTANCE

Air Volume		Step-Down Diffuser												Flush Diffuser			
		RTD11-185S						RTD11-275S						FD11-185S		FD11-275	
		2 Ends Open		1 Side/2 Ends Open		All Ends & Sides Open		2 Ends Open		1 Side/2 Ends Open		All Ends & Sides Open					
L/s	cfm	Pa	in. w.g.	Pa	in. w.g.	Pa	in. w.g.	Pa	in. w.g.	Pa	in. w.g.	Pa	in. w.g.	Pa	in. w.g.	Pa	in. w.g.
2360	5000	127	0.51	109	0.44	97	0.39	---	---	---	---	---	---	67	0.27	---	---
2455	5200	139	0.56	119	0.48	104	0.42	---	---	---	---	---	---	75	0.30	---	---
2550	5400	152	0.61	129	0.52	112	0.45	---	---	---	---	---	---	82	0.33	---	---
2645	5600	164	0.66	139	0.56	119	0.48	---	---	---	---	---	---	90	0.36	---	---
2735	5800	177	0.71	147	0.59	127	0.51	---	---	---	---	---	---	97	0.39	---	---
2830	6000	189	0.76	157	0.63	137	0.55	90	0.36	77	0.31	67	0.27	104	0.42	72	0.29
2925	6200	199	0.80	169	0.68	147	0.59	---	---	---	---	---	---	114	0.46	---	---
3020	6400	214	0.86	179	0.72	157	0.63	---	---	---	---	---	---	124	0.50	---	---
3065	6500	---	---	---	---	---	---	104	0.42	90	0.36	77	0.31	---	---	85	0.34
3115	6600	229	0.92	191	0.77	167	0.67	---	---	---	---	---	---	134	0.54	---	---
3210	6800	246	0.99	206	0.83	179	0.72	---	---	---	---	---	---	144	0.58	---	---
3305	7000	256	1.03	216	0.87	189	0.76	122	0.49	102	0.41	90	0.36	154	0.62	99	0.40
3400	7200	271	1.09	229	0.92	199	0.80	---	---	---	---	---	---	164	0.66	---	---
3490	7400	286	1.15	241	0.97	209	0.84	---	---	---	---	---	---	174	0.70	---	---
3540	7500	---	---	---	---	---	---	127	0.51	114	0.46	102	0.41	---	---	112	0.45
3585	7600	298	1.20	254	1.02	219	0.88	---	---	---	---	---	---	184	0.74	---	---
3775	8000	---	---	---	---	---	---	147	0.59	122	0.49	107	0.43	---	---	124	0.50
4010	8500	---	---	---	---	---	---	172	0.69	144	0.58	124	0.50	---	---	142	0.57
4245	9000	---	---	---	---	---	---	196	0.79	167	0.67	144	0.58	---	---	164	0.66
4485	9500	---	---	---	---	---	---	221	0.89	186	0.75	162	0.65	---	---	184	0.74
4720	10 000	---	---	---	---	---	---	249	1.00	209	0.84	182	0.73	---	---	201	0.81
4955	10 500	---	---	---	---	---	---	274	1.10	229	0.92	199	0.80	---	---	221	0.89
5190	11 000	---	---	---	---	---	---	301	1.21	251	1.01	219	0.88	---	---	239	0.96

CEILING DIFFUSER AIR THROW DATA

Model No.	Air Volume		1 Effective Throw Range				Model No.	Air Volume		1 Effective Throw Range			
	L/s	cfm	RTD11-185S Step-Down		FD11-185S Flush			L/s	cfm	RTD11-185S Step-Down		FD11-185S Flush	
			m	ft.	m	ft.				m	ft.	m	ft.
156 180	2645	5600	12 - 15	39 - 49	9 - 11	28 - 37	210 240 300	3400	7200	10 - 12	33 - 38	8 - 11	26 - 35
	2735	5800	13 - 16	42 - 51	9 - 12	29 - 38		3490	7400	11 - 12	35 - 40	9 - 11	28 - 37
	2830	6000	13 - 16	44 - 54	12 - 15	40 - 50		3585	7600	11 - 12	36 - 41	9 - 11	29 - 38
	2925	6200	14 - 17	45 - 55	13 - 16	42 - 51		3680	7800	12 - 13	38 - 43	12 - 15	40 - 50
	3020	6400	14 - 17	46 - 55	13 - 16	43 - 52		3775	8000	12 - 13	39 - 44	13 - 16	42 - 51
	3115	6600	14 - 17	47 - 56	14 - 17	45 - 56		3870	8200	12 - 14	41 - 46	13 - 16	43 - 52
							3965	8400	13 - 15	43 - 49	13 - 16	44 - 54	
							4060	8600	13 - 15	44 - 50	14 - 17	46 - 57	
							4155	8800	14 - 17	47 - 55	15 - 18	48 - 59	

¹ Throw is the horizontal or vertical distance an airstream travels on leaving the outlet diffuser before the maximum velocity is reduced to 15 m (50 ft.) per minute. Four sides open.

ELECTRICAL DATA - STANDARD EFFICIENCY

Model No.		KGB180S			KGB210S			KGB240S			KGB300S		
¹ Voltage - 50hz - 3 phase		380/420V			380/420V			380/420V			380/420V		
Compressor 1	Rated Load Amps	6.3			8			10.6			8		
	Locked Rotor Amps	55			67.1			74			67.1		
Compressor 2	Rated Load Amps	6.3			8			10.6			8		
	Locked Rotor Amps	55			67.1			74			67.1		
Compressor 3	Rated Load Amps	6.3			8			12.2			10.6		
	Locked Rotor Amps	55			67.1			101			74		
Compressor 4	Rated Load Amps	---			---			---			10.6		
	Locked Rotor Amps	---			---			---			74		
Outdoor Fan Motors	Number of motors	3			3			4			6		
	Full Load Amps	1.3			1.3			1.3			1.3		
	(total)	(3.9)			(3.9)			(5.2)			(7.8)		
Power Exhaust With (2) 0.25 kW	Full Load Amps	1.3			1.3			1.3			1.3		
	(total)	(2.6)			(2.6)			(2.6)			(2.6)		
Indoor Blower Motor	kW	2.2	3.7	5.6	2.2	3.7	5.6	3.7	5.6	7.5	3.7	5.6	7.5
	Full Load Amps	5.3	8.2	11.7	5.3	8.2	11.7	8.2	11.7	16.3	8.2	11.7	16.3
² Maximum Overcurrent Protection	Unit Only	35	40	45	40	45	50	60	60	70	60	70	80
	With (2) 0.25 kW Power Exhaust	35	40	50	45	45	50	60	60	70	60	70	80
³ Minimum Circuit Ampacity	Unit Only	30	34	38	36	39	43	50	54	59	56	60	66
	With (2) 0.25 kW Power Exhaust	33	36	41	38	41	46	53	56	62	59	63	68

¹ Extremes of operating range are plus and minus 10% of line voltage.

² Heating / Air Conditioning / Refrigeration (HACR) type breaker or fuse.

³ Refer to local codes to determine wire, fuse and disconnect size requirements.

ELECTRICAL DATA - HIGH EFFICIENCY

Model No.		KGA156H4			KGA180H4			KGA210H4			KGA240H4		
¹ Voltage - 50hz 3 Phase		380/420V			380/420V			380/420V			380/420V		
Compressor 1	Rated Load Amps	6.3			6.3			7.8			6.3		
	Locked Rotor Amps	55			55			51.5			55		
Compressor 2	Rated Load Amps	6.3			6.3			7.8			6.3		
	Locked Rotor Amps	55			55			51.5			55		
Compressor 3	Rated Load Amps	6.3			6.3			8			6.3		
	Locked Rotor Amps	55			55			67.1			55		
Compressor 4	Rated Load Amps	---			---			---			6.3		
	Locked Rotor Amps	---			---			---			55		
Outdoor Fan Motors	Number of motors	3			4			6			6		
	Full Load Amps	1.3			1.3			1.3			1.3		
	(total)	(3.9)			(5.2)			(7.8)			(7.8)		
Power Exhaust With (2) 0.25 kW	Full Load Amps	1.3			1.3			1.3			1.3		
	(total)	(2.6)			(2.6)			(2.6)			(2.6)		
Indoor Blower Motor	kW	1.5	2.2	3.7	2.2	3.7	5.6	2.2	3.7	5.6	3.7	5.6	7.5
	Full Load Amps	3.6	5.3	8.2	5.3	8.2	11.7	5.3	8.2	11.7	8.2	11.7	16.3
² Maximum Overcurrent Protection	Unit Only	30	35	40	35	40	50	45	45	50	50	50	60
	With (2) 0.25 kW Power Exhaust	35	35	40	35	45	50	45	50	60	50	60	70
³ Minimum Circuit Ampacity	Unit Only	28	30	34	31	35	39	39	42	47	44	48	54
	With (2) 0.25 kW Power Exhaust	31	33	36	34	37	42	42	45	49	46	51	56

¹ Extremes of operating range are plus and minus 10% of line voltage.

² Heating / Air Conditioning / Refrigeration (HACR) type breaker or fuse.

³ Refer to local codes to determine wire, fuse and disconnect size requirements.

UNIT CLEARANCES

Unit With Economizer

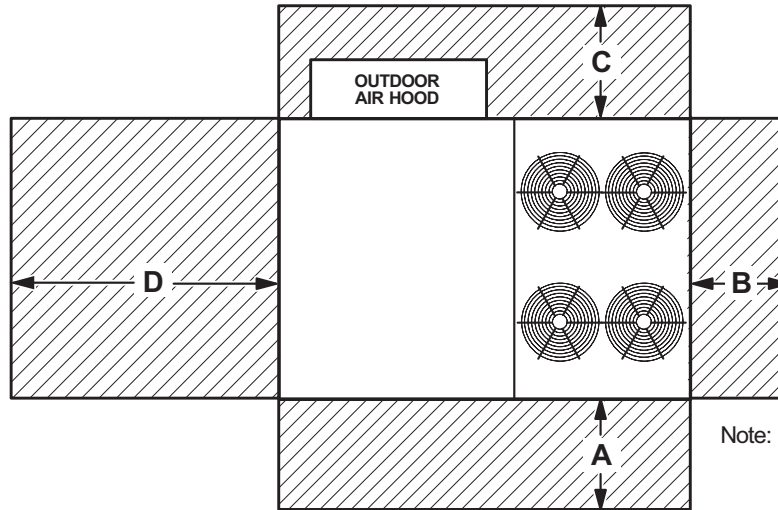

Note: 180H, 240S, 300S sizes shown

¹ Unit Clearance	A		B		C		D		Top Clearance
	mm	in.	mm	in.	mm	in.	mm	in.	
Service Clearance	1524	60	914	36	914	36	1676	66	Unobstructed
Clearance to Combustibles	914	36	25	1	25	1	25	1	
Minimum Operation Clearance	1143	45	914	36	914	36	1041	41	

NOTE - Entire perimeter of unit base requires support when elevated above the mounting surface.

¹ Service Clearance - Required for removal of serviceable parts.

Clearance to Combustibles - Required clearance to combustible material.

Minimum Operation Clearance - Required clearance for proper unit operation.

OUTDOOR SOUND DATA

Unit Model Number	Octave Band Linear Sound Power Levels dB, re 10 ⁻¹² Watts - Center Frequency - Hz							¹ Sound Rating Number (SRN) (dBA)
	125	250	500	1000	2000	4000	8000	
156H, 180S, 210S	71	78	81	81	76	71	63	86
180H, 240S	80	83	87	88	84	80	71	93
210H, 240H, 300S	79	84	88	89	85	82	73	94

Note - The octave sound power data does not include tonal corrections.

¹ Sound Rating Number according to ARI Standard 370-2001 (includes pure tone penalty). "SRN" is the overall A-Weighted Sound Power Level, (LWA), dB (100 Hz to 10,000 Hz).

WEIGHT DATA

Model Number	Outdoor Coil	Net		Shipping		Outdoor	Net		Shipping	
		kg	lbs.	kg	lbs.		kg	lbs.	kg	lbs.
156H Base Unit	Environ™	878	1935	968	2135	---	---	---	---	---
156H Max. Unit	Environ™	1000	2205	1091	2405	---	---	---	---	---
180H Base Unit	Environ™	959	2115	1050	2315	---	---	---	---	---
180H Max. Unit	Environ™	1089	2400	1179	2600	---	---	---	---	---
210H Base Unit	Environ™	1016	2240	1107	2440	---	---	---	---	---
210H Max. Unit	Environ™	1145	2525	1236	2725	---	---	---	---	---
240H Base Unit	Environ™	1055	2325	1145	2525	---	---	---	---	---
240H Max. Unit	Environ™	1184	2610	1275	2810	---	---	---	---	---
180S Base Unit	Environ™	841	1855	932	2055	Fin/Tube	870	1920	962	2120
180S Max. Unit	Environ™	987	2175	1077	2375	Fin/Tube	994	2190	1083	2390
210S Base Unit	Environ™	891	1965	982	2165	Fin/Tube	920	2030	1012	2230
210S Max. Unit	Environ™	1041	2295	1132	2495	Fin/Tube	1048	2310	1138	2510
240S Base Unit	Environ™	989	2180	1080	2380	Fin/Tube	1037	2285	1128	2485
240S Max. Unit	Environ™	1139	2510	1229	2710	Fin/Tube	1163	2565	1254	2765
300S Base Unit	Environ™	1111	2450	1202	2650	Fin/Tube	1141	2515	1232	2715
300S Max. Unit	Environ™	1243	2740	1334	2940	Fin/Tube	1249	2755	1341	2955

NOTE - Max. Unit is the unit with ALL INTERNAL OPTIONS installed. (Economizer, Standard Static Power Exhaust Fans, Controls, etc.). Does not include accessories EXTERNAL to unit.

OPTIONS / ACCESSORIES

Description	Shipping Weight		
	kg	lbs.	
ECONOMIZER / OUTDOOR AIR / EXHAUST			
Economizer			
Economizer Dampers	48	102	
Barometric Relief Dampers (downflow)	14	30	
Barometric Relief Dampers (horizontal)	9	20	
Outdoor Air Damper Hood (downflow)	29	65	
Outdoor Air Dampers			
Outdoor Air Damper Section (downflow) - Automatic (including Hood)	39	18	
Outdoor Air Damper Section (downflow) - Manual (including Hood)	22	10	
Power Exhaust	28	62	
GAS HEAT EXCHANGER (NET WEIGHT)			
Medium Heat (adder over standard heat)	8	18	
High Heat (adder over standard heat)	29	64	
MSAV® (MULTI-STAGE AIR VOLUME) SUPPLY AIR BLOWER OPTION			
Variable Frequency Drive (VFD) and associated components	5	10	
ROOF CURBS			
Hybrid Roof Curbs, Downflow			
203 mm height	34	75	
356 mm height	48	105	
457 mm height	57	125	
610 mm height	70	155	
Adjustable Pitch Curb, Downflow			
356 mm height	119	262	
Horizontal Roof Curbs, Standard			
660 mm height	231	470	
940 mm height	229	505	
762 mm height	261	575	
1041 mm height	277	610	
CEILING DIFFUSERS			
Step-Down			
	RTD11-185S	168	76
	RTD11-275S	238	108
Flush			
	FD11-185S	168	76
	FD11-275S	238	108
Transitions			
	C1DIFF33C-1	36	80
	C1DIFF34C-1	34	75
PACKAGING			
LTL Packaging (less than truck load)	141	310	

DIMENSIONS - UNIT

KGA156H, KGB180S, KGB210S

CORNER WEIGHTS

CENTER OF GRAVITY

Model No.	AA		BB		CC		DD		EE		FF	
	kg	lbs.	kg	lbs.	kg	lbs.	kg	lbs.	mm	in.	mm	in.
KGA156H Base Unit (Environ™ Coil)	215	473	167	367	219	483	278	612	1200	47-1/4	1003	39-1/2
KGA156H Max. Unit (Environ™ Coil)	266	586	203	447	232	510	301	663	1187	46-3/4	1086	42-3/4
KGB180S Base Unit (Environ™ Coil)	192	423	166	365	225	495	260	574	1270	50	984	38-3/4
KGB180S Max. Unit (Environ™ Coil)	246	542	200	441	243	536	298	657	1232	48-1/2	1041	41
KGB180S Base Unit (Fin/Tube Coil)	193	426	179	395	239	525	261	577	1245	49	1010	39-3/4
KGB180S Max. Unit (Fin/Tube Coil)	259	571	224	492	269	591	313	691	1226	48-1/4	1086	42-3/4
KGB210S Base Unit (Environ™ Coil)	210	462	176	387	231	509	276	608	1251	49-1/4	997	39-1/4
KGB210S Max. Unit (Environ™ Coil)	266	587	211	465	249	550	315	694	1213	47-3/4	1060	41-3/4
KGB210S Base Unit (Fin/Tube Coil)	211	465	189	417	245	539	277	611	1245	49	1010	39-3/4
KGB210S Max. Unit (Fin/Tube Coil)	279	616	235	516	275	604	330	729	1226	48-1/4	1086	42-3/4

Base Unit - The unit with NO INTERNAL OPTIONS.

Max. Unit - The unit with ALL INTERNAL OPTIONS Installed. (Economizer, Standard Static Power Exhaust Fans, Controls, etc.). Does not include accessories external to unit.

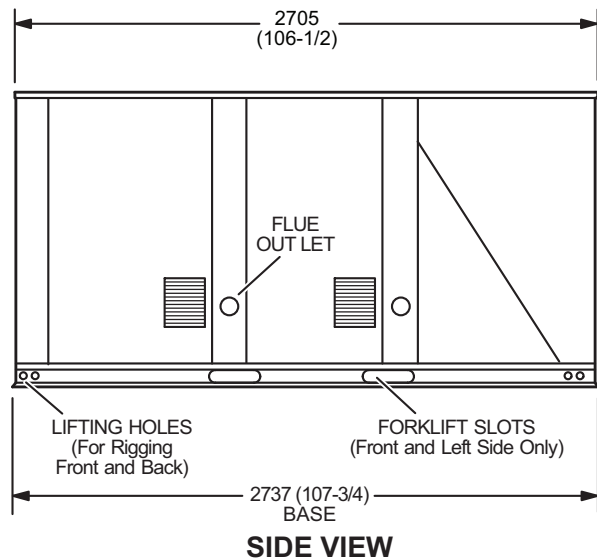
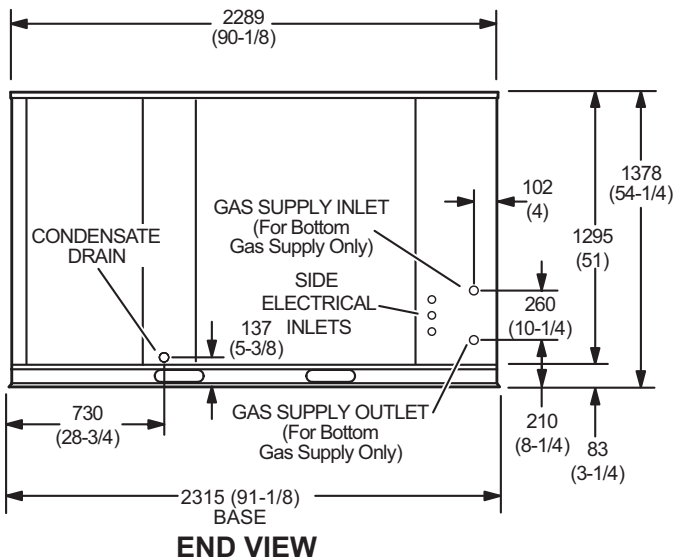
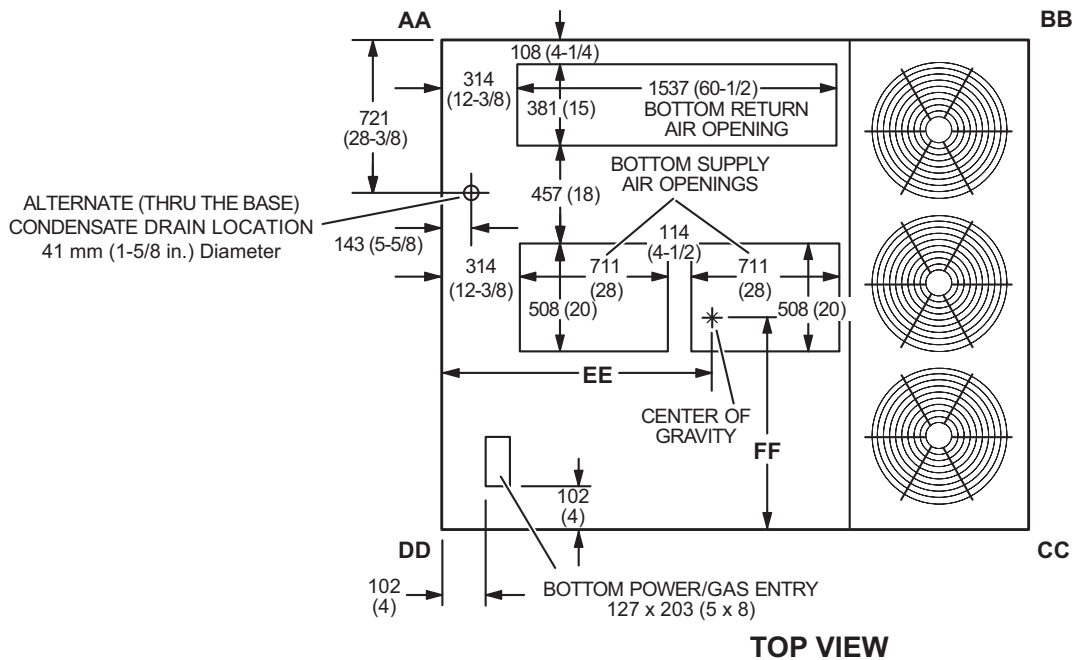

DIMENSIONS - UNIT

KGA180H, KGB240S

CORNER WEIGHTS

CENTER OF GRAVITY

Model No.	AA		BB		CC		DD		EE		FF	
	kg	lbs.	kg	lbs.	kg	lbs.	kg	lbs.	mm	in.	mm	in.
KGA180H Base Unit (Environ™ Coil)	221	487	192	423	259	569	289	636	1289	50-3/4	997	39-1/4
KGA180H Max. Unit (Environ™ Coil)	272	597	229	505	272	599	318	699	1264	49-3/4	1067	42
KGB240S Base Unit (Environ™ Coil)	210	464	191	421	279	616	308	679	1302	51-1/4	940	37
KGB240S Max. Unit (Environ™ Coil)	260	574	230	506	303	669	344	759	1283	50-1/2	997	39-1/4
KGB240S Base Unit (Fin/Tube Coil)	210	464	215	474	302	669	307	679	1353	53-1/4	1003	39-1/2
KGB240S Max. Unit (Fin/Tube Coil)	272	599	265	587	343	756	360	793	1321	52	1067	42

Base Unit - The unit with NO INTERNAL OPTIONS.

Max. Unit - The unit with ALL INTERNAL OPTIONS Installed. (Economizer, Standard Static Power Exhaust Fans, Controls, etc.). Does not include accessories external to unit.

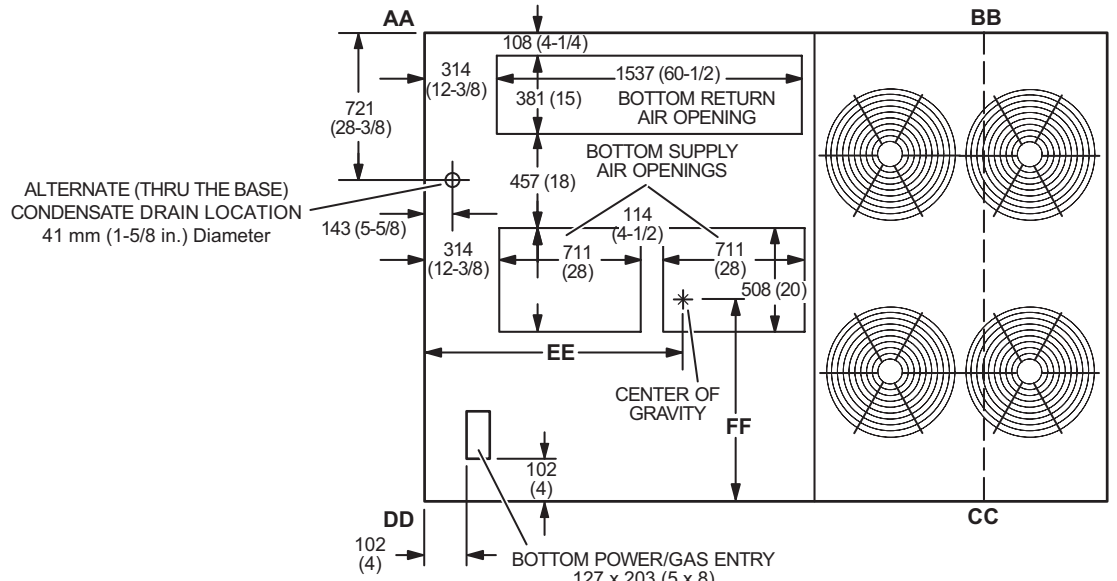

TOP VIEW

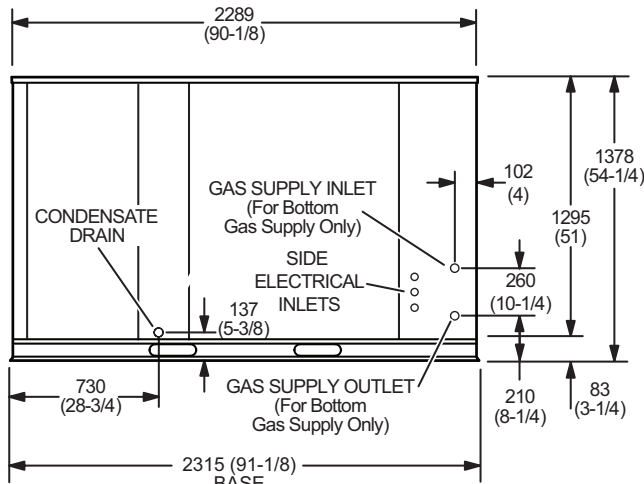

END VIEW

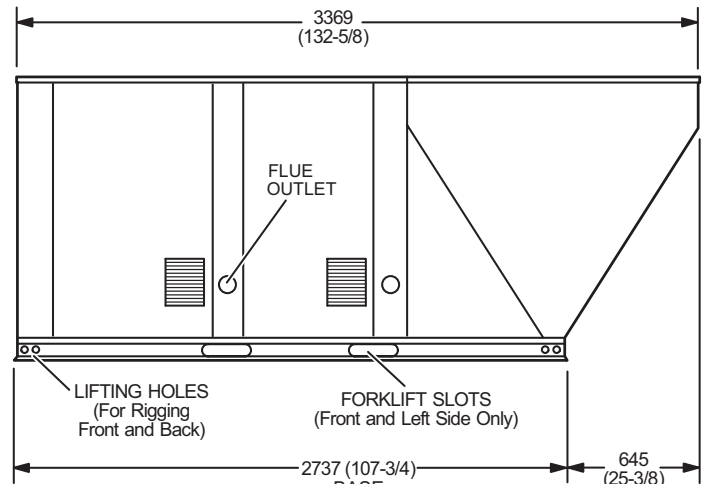

SIDE VIEW

DIMENSIONS - UNIT

KGA210H, KGB240H, KGB300S

CORNER WEIGHTS

CENTER OF GRAVITY

Model No.	AA		BB		CC		DD		EE		FF	
	kg	lbs.	kg	lbs.	kg	lbs.	kg	lbs.	mm	in.	mm	in.
KGA210H Base Unit (Environ™ Coil)	226	497	213	468	284	626	295	649	1340	52-3/4	997	39-1/4
KGA210H Max. Unit (Environ™ Coil)	276	607	252	553	298	655	323	710	1308	51-1/2	1067	42
KGA240H Base Unit (Environ™ Coil)	230	507	219	481	300	660	308	677	1346	53	984	38-3/4
KGA240H Max. Unit (Environ™ Coil)	280	617	258	567	313	688	335	738	1321	52	1054	41-1/2
KGB300S Base Unit (Environ™ Coil)	232	511	229	505	324	714	327	722	1359	53-1/2	959	37-3/4
KGB300S Max. Unit (Environ™ Coil)	283	624	269	594	337	743	354	780	1334	52-1/2	1029	40-1/2
KGB300S Base Unit (Fin/Tube Coil)	243	535	228	501	325	716	346	764	1359	53-1/2	959	37-3/4
KGB300S Max. Unit (Fin/Tube Coil)	307	677	280	616	350	771	384	847	1334	52-1/2	1029	40-1/2

Base Unit - The unit with NO INTERNAL OPTIONS.

Max. Unit - The unit with ALL INTERNAL OPTIONS Installed. (Economizer, Standard Static Power Exhaust Fans, Controls, etc.). Does not include accessories external to unit.

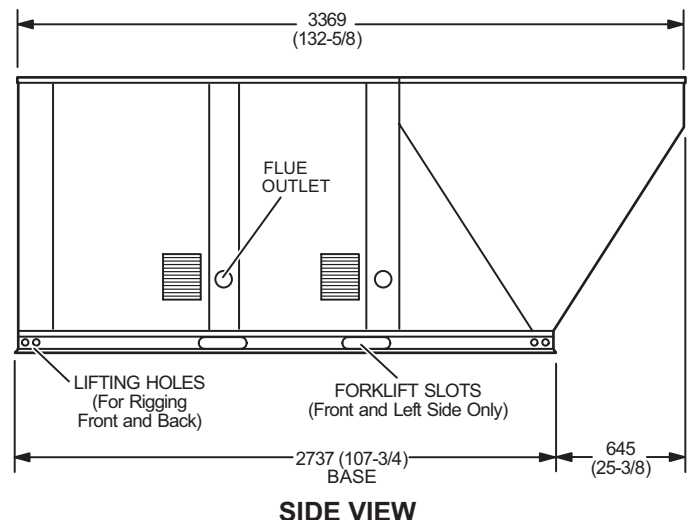
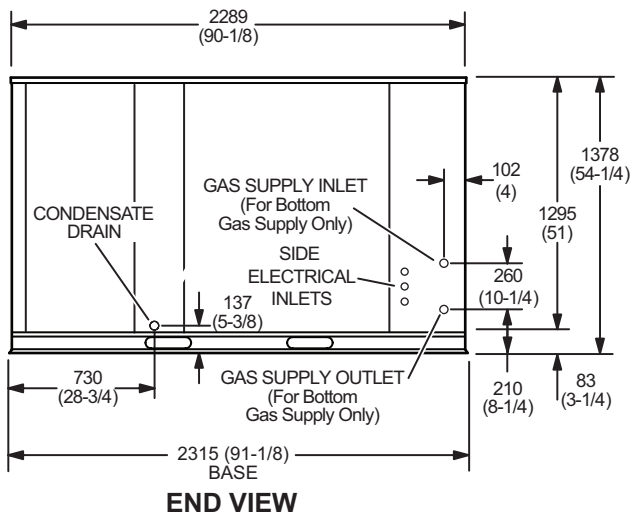
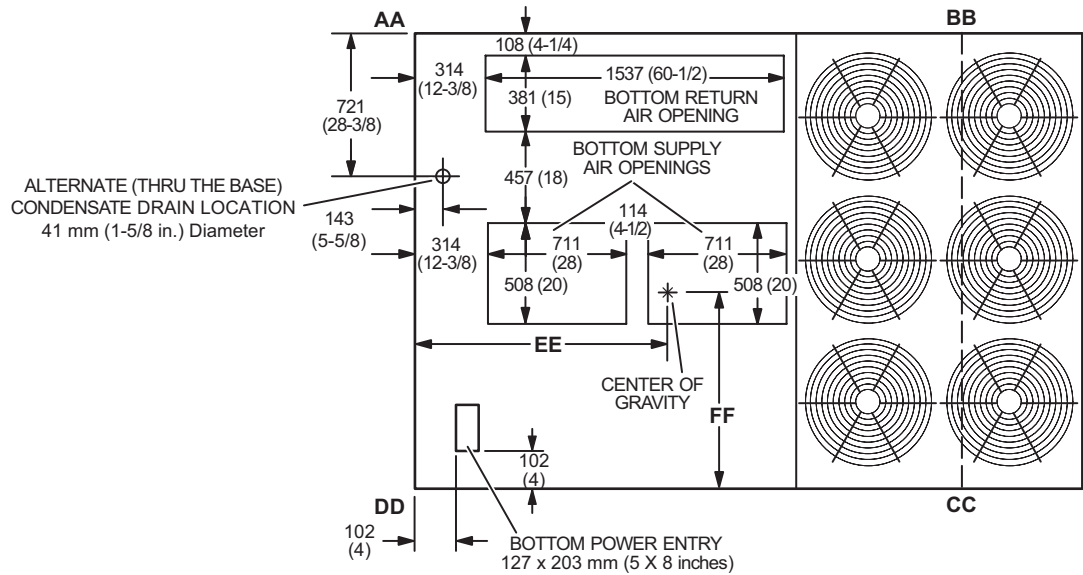

OUTDOOR AIR HOOD DETAIL

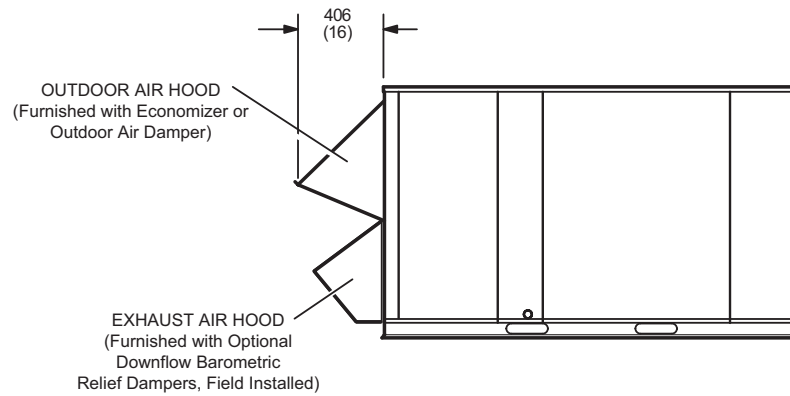

OPTIONAL HORIZONTAL BAROMETRIC RELIEF DAMPERS WITH HOOD

(Field installed in horizontal return air duct adjacent to unit)

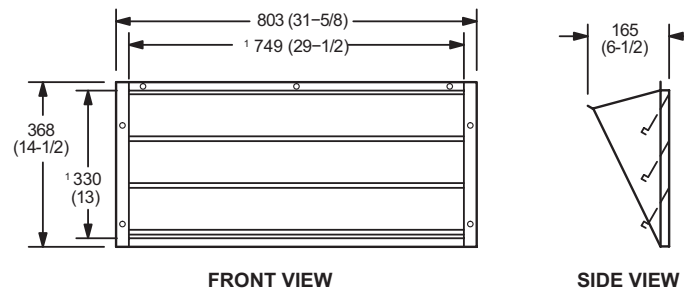

NOTE - Two furnished per order number.
¹ NOTE - Opening size required in return air duct.

DIMENSIONS - ACCESSORIES

HYBRID ROOF CURBS - DOUBLE DUCT OPENING

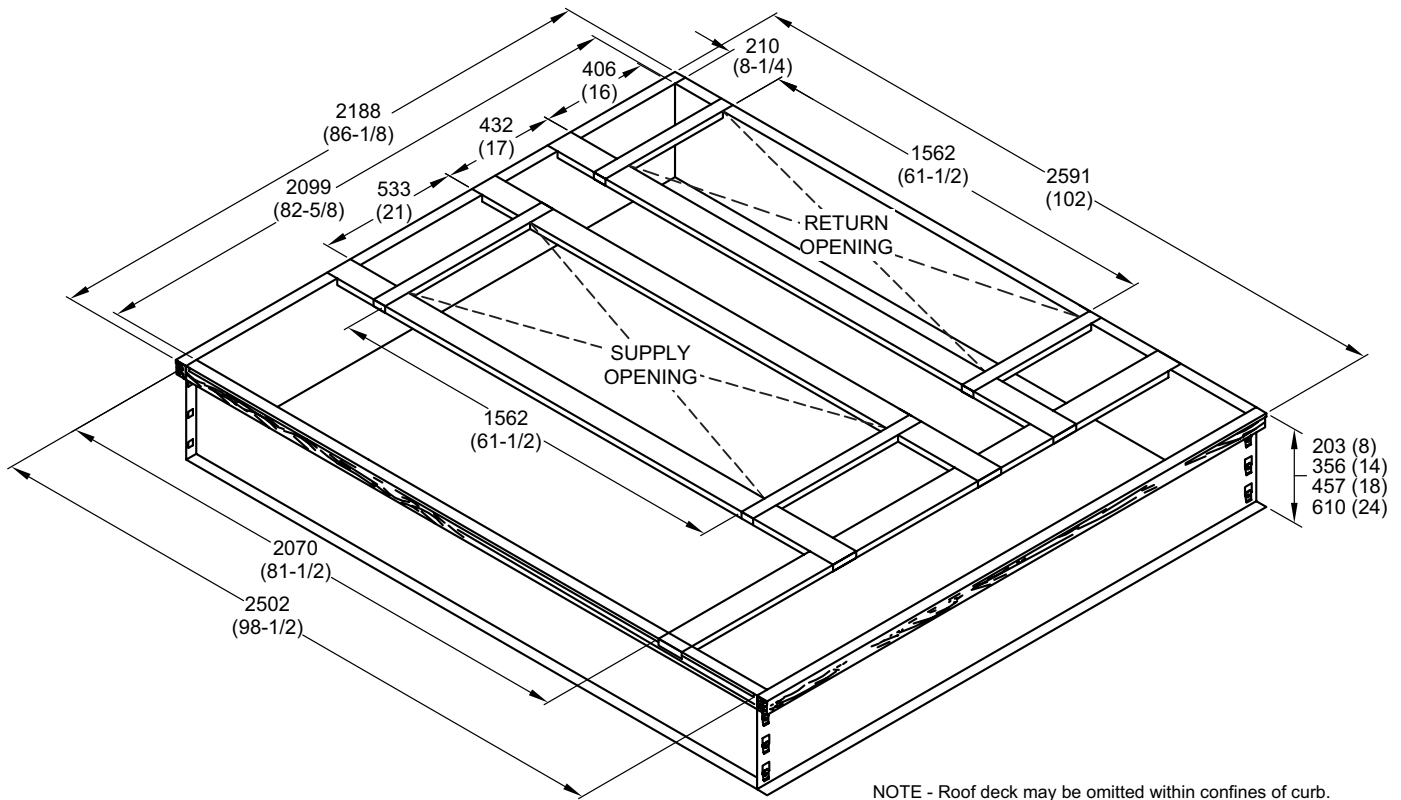

TYPICAL FLASHING DETAIL FOR ROOF CURB

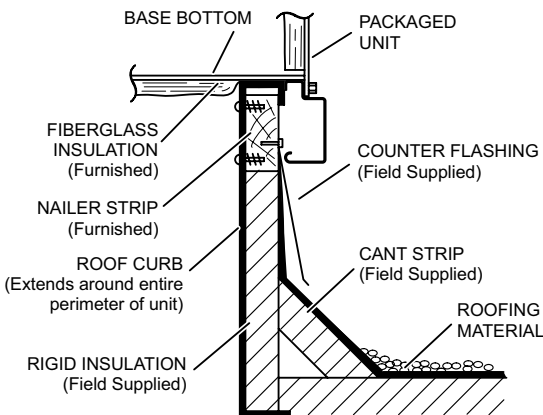

DETAIL ROOF CURB

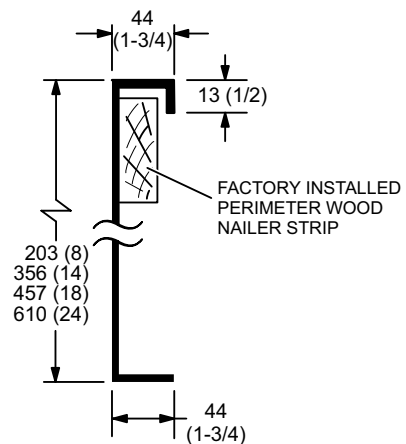

DIMENSIONS - ACCESSORIES

ADJUSTABLE PITCH CURB - DOUBLE DUCT OPENING

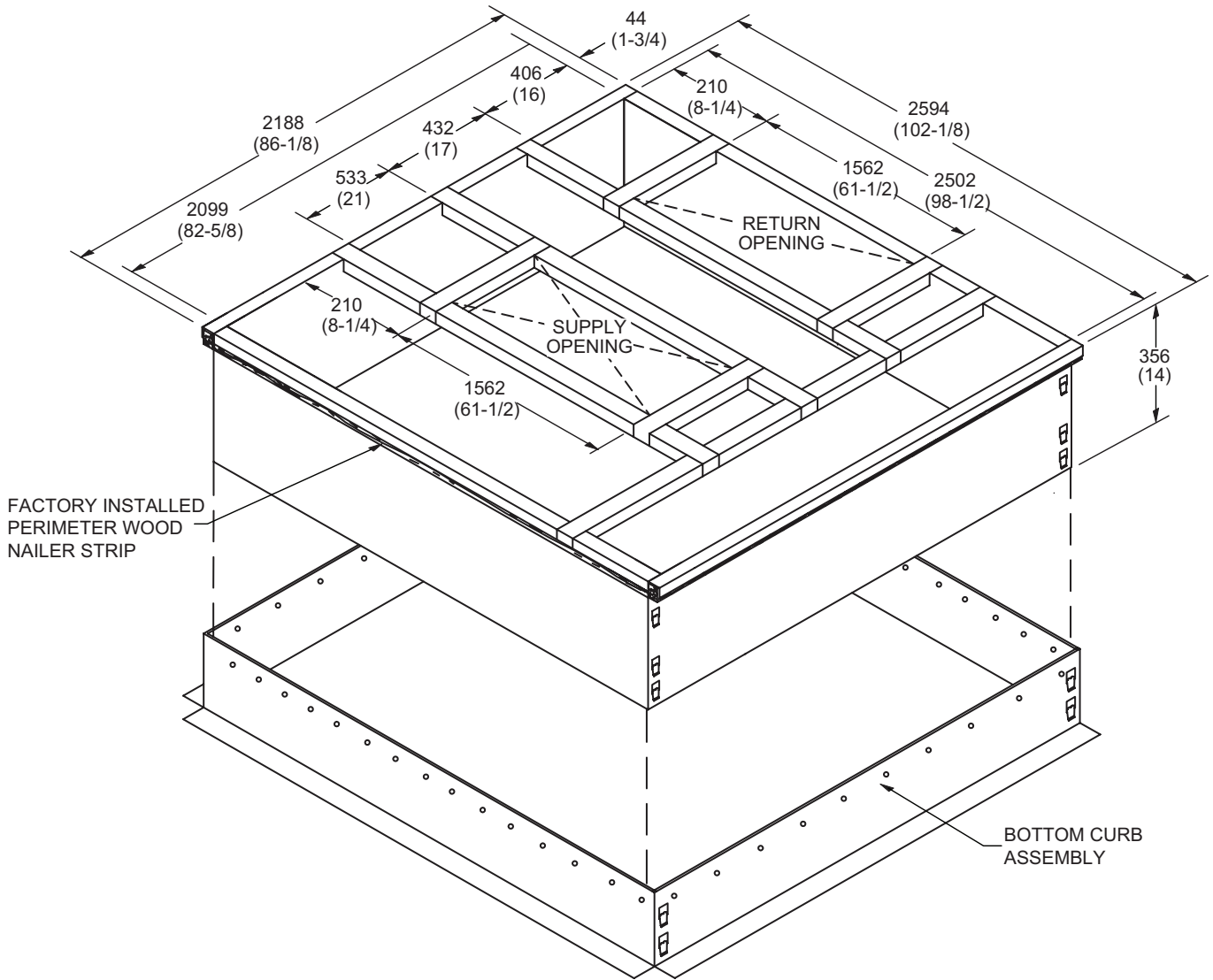

NOTE - Maximum slope pitch is 19 mm per 305 mm (3/4 inch per foot) in any one direction.

TYPICAL FLASHING DETAIL FOR ROOF CURB

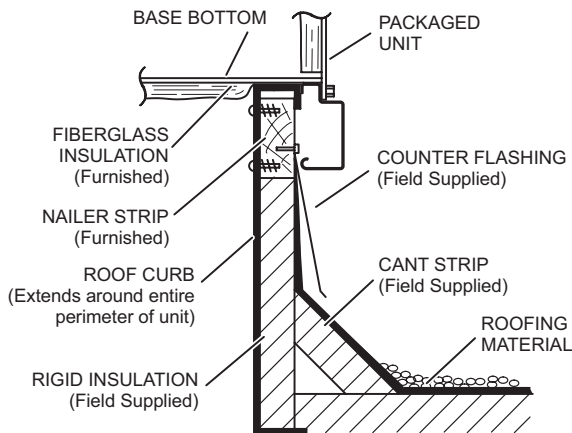

DETAIL ROOF CURB

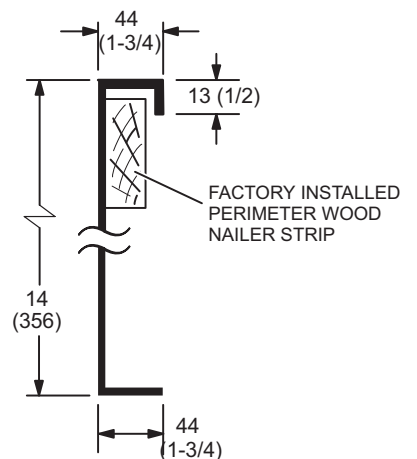

DIMENSIONS - ACCESSORIES

ROOF CURBS WITH SUPPLY & RETURN AIR TRANSITIONS FOR CEILING DIFFUSERS

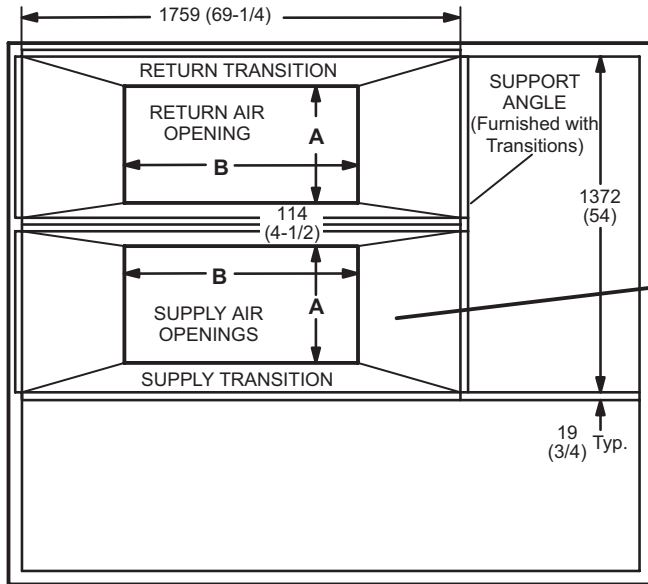

TOP VIEW

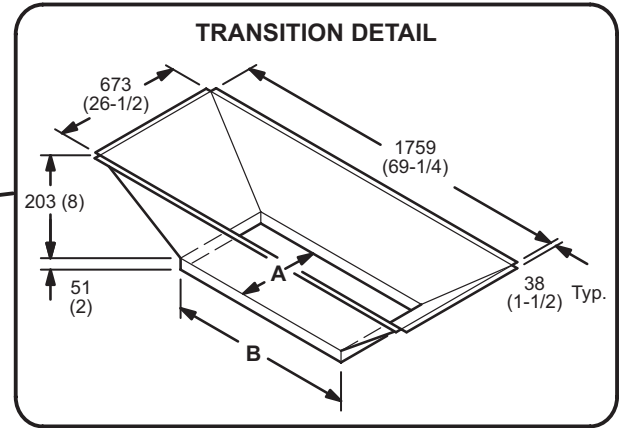

TRANSITION OPENING SIZES

Model Number	A		B	
	mm	inch	mm	inch
C1DIFF33C-1	457	18	914	36
C1DIFF34C-1	610	24	1219	48

DIMENSIONS - ACCESSORIES

HORIZONTAL ROOF CURBS – Requires Optional Horizontal Return Air Panel Kit

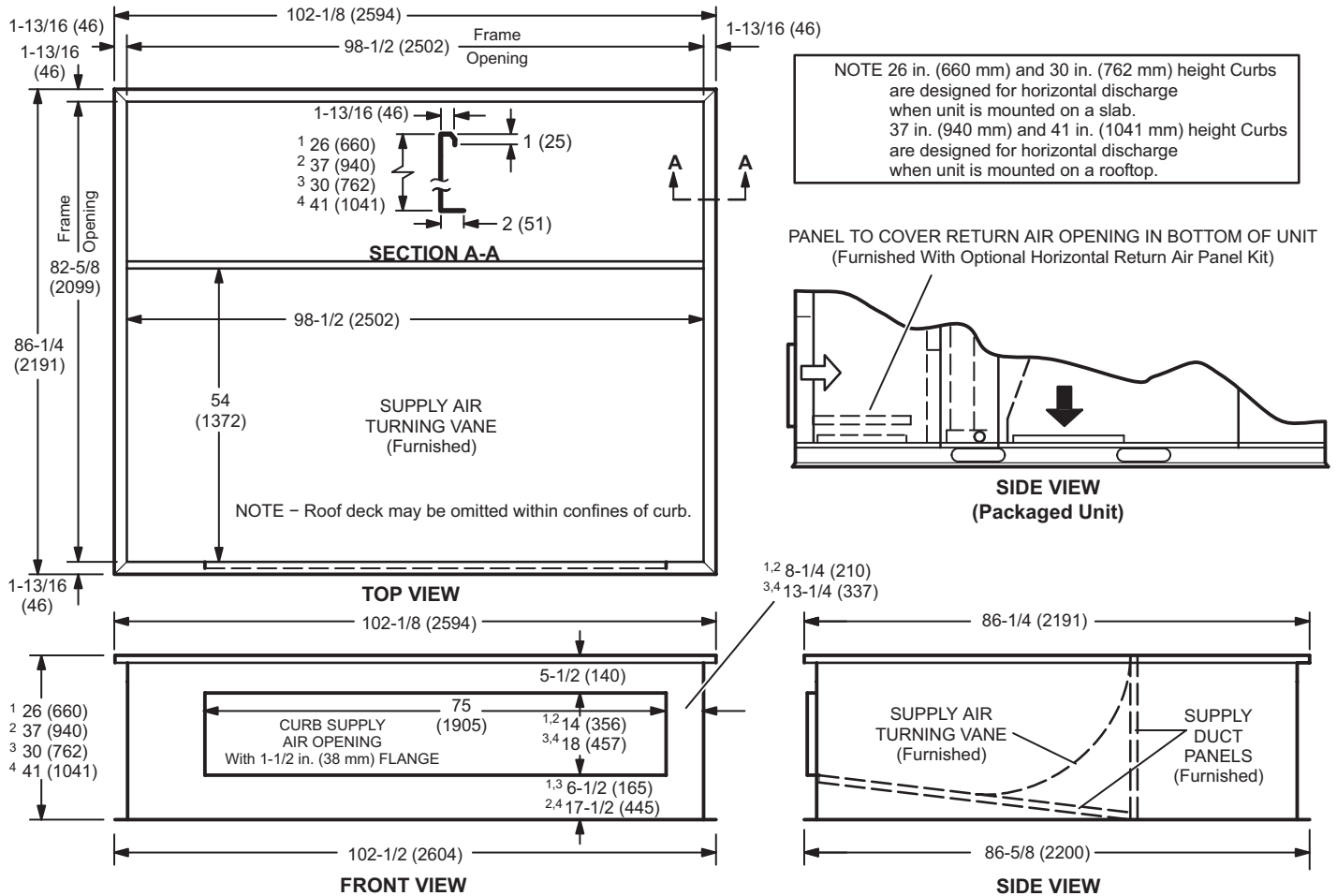

1 Slab Applications 2 Rooftop Applications 3 Slab Applications (used with 300S) 4 Rooftop Applications (used with 300S)

HORIZONTAL SUPPLY AND RETURN AIR OPENINGS WITH HORIZONTAL ROOF CURB

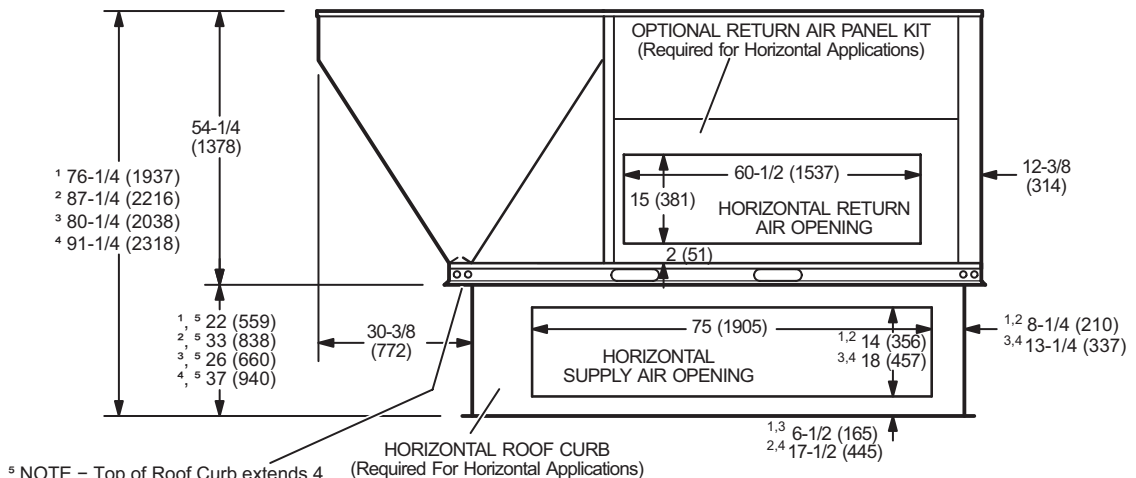

⁵ NOTE – Top of Roof Curb extends 4 inch (102 mm) inside bottom of unit base. See Typical flashing detail.

1 Slab Applications
2 Rooftop Applications
3 Slab Applications (used with 300S Models Only)
4 Rooftop Applications (used with 300S Models Only)

DIMENSIONS - ACCESSORIES

COMBINATION CEILING SUPPLY AND RETURN DIFFUSERS

STEP-DOWN CEILING DIFFUSER

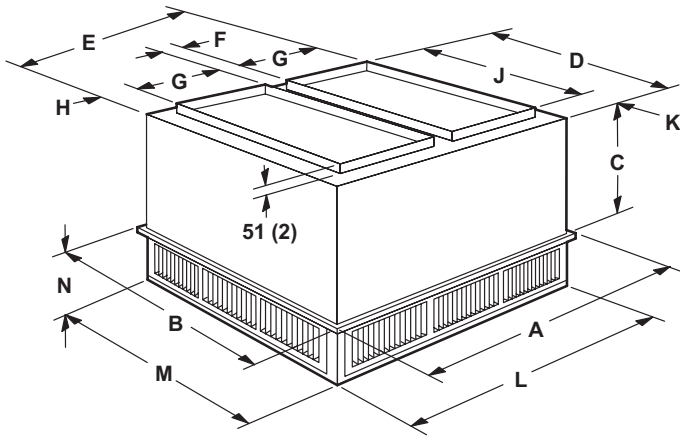

FLUSH CEILING DIFFUSER

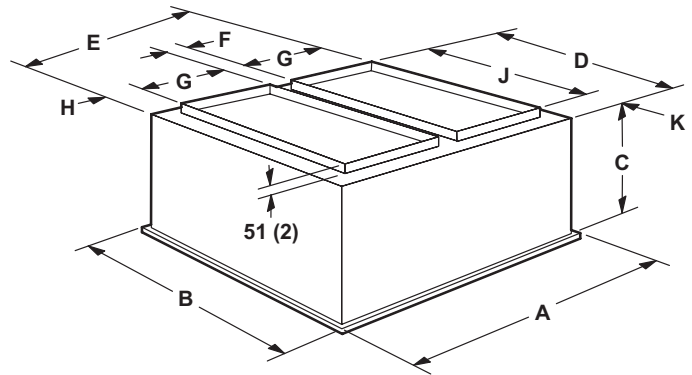

Model Number		RTD11-185S	RTD11-275S
A	mm	1210	1514
	in.	47-5/8	59-5/8
B	mm	1210	1514
	in.	47-5/8	59-5/8
C	mm	625	778
	in.	24-5/8	30-5/8
D	mm	1156	1461
	in.	45-1/2	57-1/2
E	mm	1156	1461
	in.	45-1/2	57-1/2
F	mm	114	114
	in.	4-1/2	4-1/2
G	mm	457	610
	in.	18	24
H	mm	64	64
	in.	2-1/2	2-1/2
J	mm	914	1219
	in.	36	48
K	mm	121	121
	in.	4-3/4	4-3/4
L	mm	1156	1461
	in.	45-1/2	57-1/2
M	mm	1156	1461
	in.	45-1/2	57-1/2
N	mm	257	283
	in.	10-1/8	11-1/8
Duct Size	mm	457 x 914	610 x 1219
	in.	18 x 36	24 x 48

Model Number		FD11-185S	FD11-275S
A	mm	1210	1514
	in.	47-5/8	59-5/8
B	mm	1210	1514
	in.	47-5/8	59-5/8
C	mm	743	895
	in.	29-1/4	35-1/4
D	mm	1143	1148
	in.	45	57
E	mm	1143	1448
	in.	45	57
F	mm	114	114
	in.	4-1/2	4-1/2
G	mm	457	610
	in.	18	24
H	mm	57	57
	in.	2-1/4	2-1/4
J	mm	914	1219
	in.	36	48
K	mm	114	114
	in.	4-1/2	4-1/2
Duct Size	mm	457 x 914	610 x 1219
	in.	18 x 36	24 x 48

REVISIONS

Sections	Description of Change
Options/Accessories	Catalog numbers revised for: Economizers Single Enthalpy



Visit us at www.lennox.com

For the latest technical information, www.lennoxcommercial.com

Contact us at 1-800-4-LENNOX

NOTE - Due to Lennox' ongoing commitment to quality, Specifications, Ratings and Dimensions subject to change without notice and without incurring liability. Improper installation, adjustment, alteration, service or maintenance can cause property damage or personal injury. Installation and service must be performed by a qualified installer and servicing agency.

©2021 Lennox Industries, Inc.