



**COMMERCIAL  
PRODUCT SPECIFICATIONS**



**LANDMARK®**  
Performance Marked by Flexibility™

**Nominal Capacity - 10.5 to 26.4 kW (3 to 7.5 Ton)**  
**Net Cooling Capacity - 9.1 to 22.4 kW (31 000 to 76 500 Btuh)**  
**Gas Input Heat Capacity - 16.7 to 38.7 kW (57 000 to 132 000 Btuh)**

**MODEL NUMBER IDENTIFICATION**

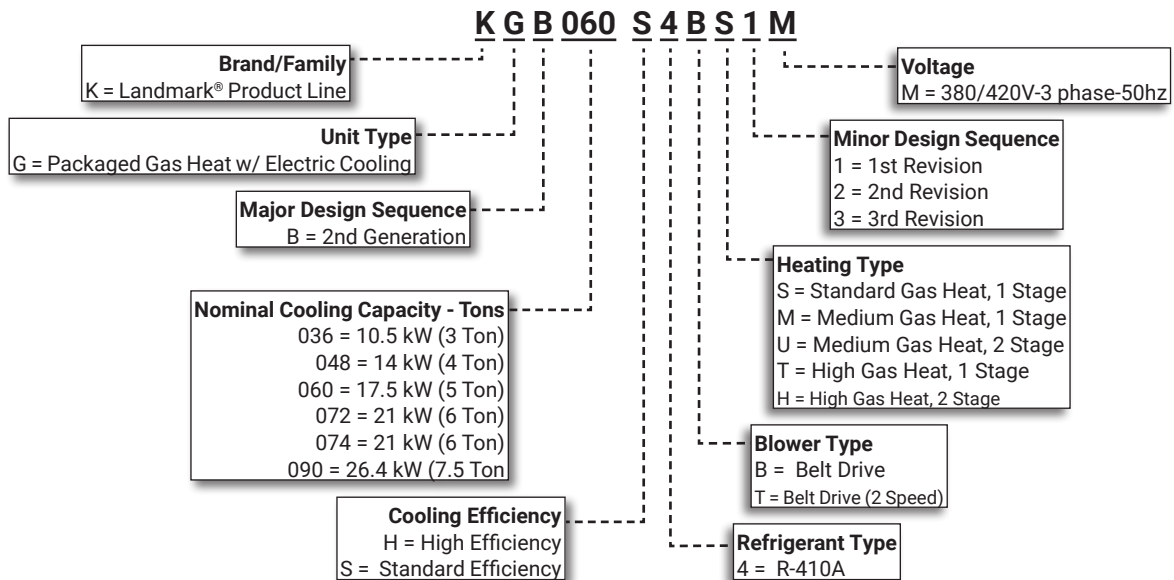

## FEATURE HIGHLIGHTS

Landmark® rooftop units from Lennox are the new standard for reliable, efficient rooftop units built for long-lasting performance that can significantly improve indoor environments.

1. Aluminized Steel Inshot Burners
2. Electronic Pilot Ignition
3. Single Speed Scroll Compressor
4. Thermal Expansion Valve
5. Lennox' Environ™ Coil System
6. Outdoor Coil Fan Motor
7. Construction
8. Power/Gas Entry
9. Exterior Panels
10. Insulation
11. Hinged Access Panels
12. Supply Air Blower
13. Economizer (Optional)

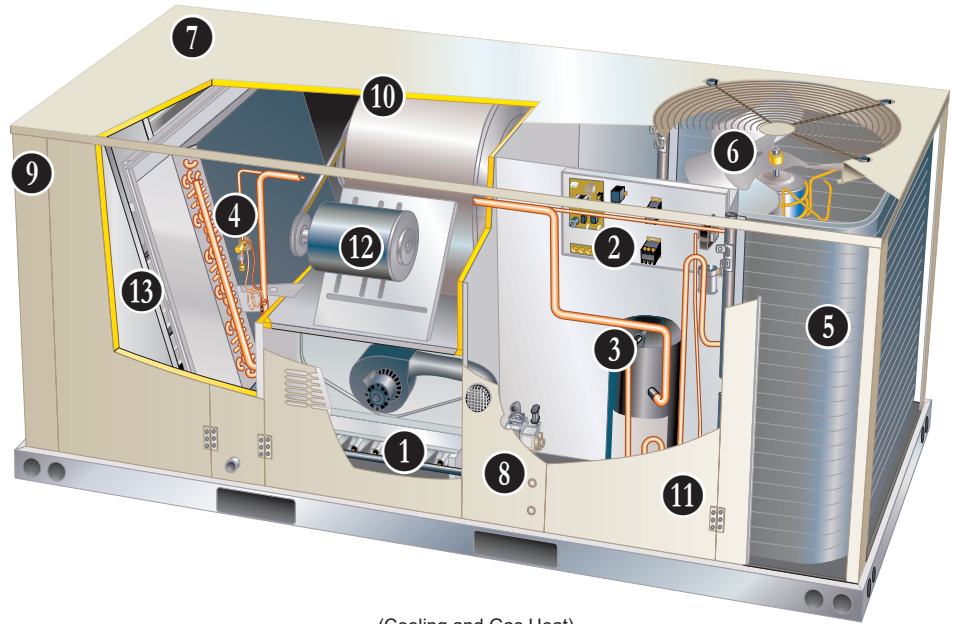

(Cooling and Gas Heat)

Shown With Optional Electric Heat, Economizer, Power Exhaust and Hinged Access Panels

## CONTENTS

Blower Data . . . . .	28
Dimensions . . . . .	46
- Unit . . . . .	46
- Accessories . . . . .	47
Electrical Data . . . . .	43
Feature Highlights . . . . .	2
Features And Benefits . . . . .	3
High Altitude Derate . . . . .	18
Model Number Identification . . . . .	1
Optional Conventional Temperature Control Systems . . . . .	10
Options / Accessories . . . . .	11
Outdoor Sound Data . . . . .	44
Ratings . . . . .	19
Specifications . . . . .	14
Specifications - Gas Heat . . . . .	18
Unit Clearances . . . . .	44
Weight Data . . . . .	45

## PERFORMANCE/QUALITY AND CE MARK OPTION

### TESTING

- Components bonded for grounding to meet safety standards for servicing required by Underwriters Laboratories (UL) and the International Electrotechnical Commission (IEC)
- 10.5 through 17.5 kW models cooling performance is rated at test conditions included in Air-Conditioning, Heating and Refrigeration Institute (AHRI) Standard 210/240-2008 while operating at rated voltage and air volumes
- 21.0 kW and 26.4 kW models cooling performance is rated at test conditions included in Air-Conditioning, Heating and Refrigeration Institute (AHRI) Standard 340/360-2007 while operating at rated voltage and air volumes
- International Organization for Standardization (ISO) 9001 Registered Manufacturing Quality System

## FEATURES AND BENEFITS

### HEATING SYSTEM

- 1 • Aluminized steel inshot burners
  - Direct spark ignition
  - Electronic flame sensor
  - Combustion air inducer
  - Redundant automatic single or dual stage gas valve with manual shut-off

#### Heat Exchanger

- Tubular construction
- Aluminized steel
- Life cycle tested

**NOTE** - Stainless Steel Heat Exchanger is required if mixed air temperature is below 7°C.

- 2 • **Electronic Pilot Ignition**

- Electronic spark igniter provides positive direct ignition of burners on each operating cycle
- System permits main gas valve to stay open only when the burners are proven to be lit
- Should a loss of flame occur, the gas valve closes, shutting off the gas to the burners
- Ignition module has LED to indicate status and aid in troubleshooting
- Watchguard circuit on module automatically resets ignition controls after one hour of continuous thermostat demand after unit lockout, eliminating nuisance service calls
- Ignition control is factory installed in the controls section

#### Limit Controls

- Factory installed
- Redundant limit controls with fixed temperature setting
- Protect heat exchanger and other components from overheating

#### Safety Switches

- Flame roll-out switch
- Flame sensor and combustion air inducer proving switch protect system operation

### Required Selections

#### Gas Input Choice - Order one:

- Standard Gas Heat, 1 Stage - 16.7 kW
- Medium Gas Heat, 1 Stage - 27.8 kW
- Medium Gas Heat, 2 Stage - 20.8 / 27.8 kW
- High Gas Heat, 1 Stage - 38.7 kW
- High Gas Heat, 2 Stage - 29.0 / 38.7 kW

### Options / Accessories

#### Factory Installed

##### Stainless Steel Heat Exchanger

- Required if mixed air temperature is below 7°C

#### Field Installed

##### Combustion Air Intake Extensions

- Recommended for use with existing flue extension kits in areas where high snow areas can block intake air

##### Low Temperature Vestibule Heater

- Electric heater automatically controls minimum temperature in gas burner compartment when temperature is below -40°C
- Allows operation of unit down to -51°C

#### Propane Kits

- Conversion kit to field change over units from Natural Gas to Propane

#### Vertical Vent Extension Kit

- Use to exhaust flue gases vertically above unit
- Required when unit vent is too close to fresh air intakes per building codes
- Also prevents ice formation on intake louvers

## FEATURES AND BENEFITS

### COOLING SYSTEM

- Designed to maximize sensible and latent cooling performance at design conditions
- System can operate from -1°C to 52°C without any additional controls

#### R-410A Refrigerant

- Non-chlorine
- Ozone friendly
- Unit pre-charged with refrigerant
- See Specification table

### 3 Single Speed Scroll Compressor (036 through 072 Models)

- Scroll compressors for high performance, reliability and quiet operation
- Resiliently mounted on rubber grommets for quiet operation

#### Two-Stage Scroll Compressor (074 and 090 Models)

- Two-stage for increased part load efficiency, high performance, reliability and quiet operation
- Resiliently mounted on rubber grommets for quiet operation

#### Compressor Crankcase Heater

- Protects against refrigerant migration that can occur during low ambient operation

### 4 Thermal Expansion Valve

- Ensures optimal performance throughout the application range
- Removable element head

#### High Pressure Switch

- Protects the compressor from overload conditions such as dirty condenser coils, blocked refrigerant flow, or loss of outdoor fan operation

#### Filter/Drier

- High capacity filter/drier protects the system from dirt and moisture

#### Freezestat

- Protects the evaporator coil from damaging ice build-up due to conditions such as low/no air flow, or low refrigerant charge

### 5 Lennox' Environ™ Coil System

- Condenser coil features lightweight, all aluminum brazed fin construction
- Constructed of three components:
  - A flat extrusion tube
  - Fins in-between the flat extrusion
  - Two refrigerant manifolds

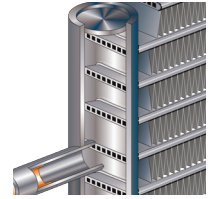

#### Environ™ Coil System Features:

- Improved heat transfer performance due to high primary surface area (flat tubes) versus secondary surface (fins)
- Smaller internal volume (reduced refrigerant charge)
- High durability (all aluminum construction)
- Fewer brazed joints
- Compact design (reduces unit weight)
- Easy maintenance/cleaning
- Mounting brackets with rubber inserts secure coil to unit providing vibration dampening and corrosion protection.

#### Evaporator Coil

- Copper tube construction
- Enhanced rippled-edge aluminum fins
- Flared shoulder tubing connections
- Silver soldered construction
- Factory leak tested
- Cross row circuiting with rifled tubing

#### Condensate Drain Pan

- Plastic pan, sloped to meet drainage requirements of American Society of Heating Refrigeration and Air Conditioning Engineers 62.1
- Side or bottom drain connections
- Reversible to allow connection at back of unit

### 6 Outdoor Coil Fan Motor

- Thermal overload protected
- Totally enclosed
- Permanently lubricated sleeve bearings (024, 030, 036 and 048 models)
- Permanently lubricated ball bearings (060, 072, 074, and 090 models)
- Shaft up
- Wire basket mount

#### Outdoor Coil Fan

- Polyvinyl chloride (PVC) coated fan guard furnished

### Required Selections

#### Cooling Capacity

- Specify nominal cooling capacity of the unit

## FEATURES AND BENEFITS

### **COOLING SYSTEM (continued)**

#### Options / Accessories

#### **Factory Installed**

Conventional Fin/Tube Condenser Coil (replaces Environ™ Coil System) (All Models except 072 and 074H)

- Copper tube construction
- Enhanced rippled-edge aluminum fins
- Flared shoulder tubing connections
- Silver soldered construction

#### **Field Installed**

##### Condensate Drain Trap

- Field installed only
- Available in copper or polyvinyl chloride (PVC)

##### Drain Pan Overflow Switch

- Monitors condensate level in drain pan, shuts down unit if drain becomes clogged

##### Low Ambient Kit

- Cycles the outdoor fan while allowing compressor operation in the cooling cycle
- This intermittent fan operation allows the system to operate without icing the evaporator coil and losing capacity
- Designed for use in ambient temperatures no lower than -18°C.

**NOTE** - A crankcase heater must be installed on the compressor.

### **CABINET**

#### **7 Construction**

- Heavy-gauge steel panels
- Two-layer enamel paint finish
- Full perimeter heavy-gauge galvanized steel base rail
- Base rails have rigging holes
- Three sides of the base rail have forklift slots
- Raised edges around duct and power entry openings in the bottom of the unit for water protection

##### Airflow Choice

- Units are shipped in downflow (vertical) return air configuration
- Can be field converted to horizontal air flow configuration without the need of a kit

#### **8 Power/Gas Entry**

- Electrical and gas lines can be brought through the unit base or through horizontal access knock-outs

**NOTE** - Optional Bottom Gas Entry Kit is available.

#### **9 Exterior Panels**

- Constructed of heavy-gauge, galvanized steel with a two-layer enamel paint finish

#### **10 Insulation**

- Fully insulated with non-hygroscopic fiberglass insulation (conditioned areas)
- Unit base is fully insulated
- Base insulation serves as an air seal to the roof curb, eliminating the need to add a seal during installation

##### Access Panels

- Economizer/Filter section
- Heating/Blower section
- Compressor/Controls section

**NOTE** - 060/074/090 models include a filler panel for proper cabinet fit for optional accessories (Economizers, Power Exhaust, Outdoor Air Dampers and Barometric Relief Dampers).

#### Options / Accessories

#### **Factory Installed**

##### Corrosion Protection

- Completely flexible immersed coating
- Electrodeposited dry film process
- AST ElectroFin E-Coat
- Meets Mil Spec MIL-P-53084, ASTM B117 Standard Method Salt Spray Testing
- Indoor Corrosion Protection:
  - Coated coil
  - Coated reheat coil
  - Painted blower housing
  - Painted base
- Outdoor Corrosion Protection:
  - Coated coil
  - Painted outdoor base

#### **11 Hinged Access Panels**

- Economizer/Filter section
- Heating/Blower section
- Compressor/Controls section
- Panel seals and quarter-turn latching handles provide a tight air and water seal

#### **Field Installed**

##### Combination Coil/Hail Guards

- Heavy gauge steel frame
- Painted to match cabinet
- Expanded metal mesh protects outdoor coil

##### Bottom Gas Entry Kit

- Field installed piping kit to facilitate bottom gas entry

## FEATURES AND BENEFITS

### CONTROLS

#### Unit Control

- All control voltage is provided via a 24V (secondary) transformer with built-in circuit breaker protection
- Up to 2 heat / 2 cool staging with a third party DDC control system or thermostat
- Low voltage terminal block provides screw terminal connections for thermostat or controller wiring
- Night Setback Mode saves energy by closing outdoor air dampers and operating supply fan on thermostat demand only

### Options / Accessories

#### Field Installed

##### Smoke Detector

- Photoelectric type
- Installed in supply air section, return air section or both sections
- Available with power board and single sensor (supply or return) or power board and two sensors (supply and return)
- Power board located in unit control compartment

##### Thermostats

- Control system and thermostat options, see page 44

### BLOWER

- 12** A wide selection of supply air blower options are available to meet a variety of air flow requirements.

#### Motor

- Overload protected
- Equipped with ball bearings
- Single Speed belt drive motors are offered on 036, 048, 060, and 072 models and are available in several different sizes to maximize air performance
- Two-speed belt drive motors (low static/high static) are available on 074S4T, 074H4T, and 090S4T models in several different sizes to maximize air performance

#### Supply Air Blower

- Forward curved blades
- Blower wheel statically and dynamically balanced
- Belt drive motors have adjustable pulley for speed change

#### Ordering Information

- Specify drive kit number when base unit is ordered

### Required Selections

#### Supply Air Blower

- Order one drive kit, see Drive Kit Specifications Table

### INDOOR AIR QUALITY

#### Air Filters

- Disposable 51 mm filters furnished as standard

### Options / Accessories

#### Field Installed

##### Healthy Climate® UVC Germicidal Lamps

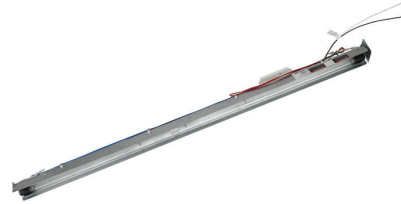

- Germicidal lamps emit ultra-violet (UV-C) energy, which has been proven to be effective in reducing microbes such as viruses, bacteria, yeasts, and molds
- This process either destroys the organism or controls its ability to reproduce
- UV-C energy greatly reduces the growth and proliferation of mold and other bioaerosols (bacteria and viruses) on illuminated surfaces (particularly coil and drain pan)
- Field installed in the blower/evaporator coil section
- Magnetic safety interlock terminates power when access panels are removed
- All necessary hardware for installation is included
- Lamps operate on 220V-1ph power supply

**NOTE** - Step-down transformer must be field supplied for field installation for 380/420V primary to 220V secondary.

##### Indoor Air Quality (CO<sub>2</sub>) Sensor

- Monitors CO<sub>2</sub> levels adjusts economizer dampers as needed for Demand Control Ventilation

### ELECTRICAL

- All units include terminal block and fuse block in power entry junction box for single power entry application

#### Marked & Color-Coded Wiring

- All electrical wiring is color-coded and marked to identify which components it is connecting

#### Electrical Plugs

- Positive connection electrical plugs are used to connect common accessories or maintenance parts for easy removal or installation

### Required Selections

#### Voltage Choice

- Specify when ordering base unit



### ECONOMIZER

#### Factory or Field Installed

#### 13 Economizer (Standard and High Performance Common Features)

- Combination Outdoor Air Hood is furnished
- Factory installed Economizer can be ordered with two exhaust options
  - Barometric Relief Dampers
  - No Exhaust
- Field installed Economizer includes Barometric Relief Dampers with Combination Hood
- Barometric Relief Dampers allow relief of excess air, dampers prevent blow back and outdoor air infiltration during off cycle, bird screen furnished

**NOTE** - Barometric Relief Dampers are required when Economizer is factory installed with field installed Power Exhaust Fan option. See Power Exhaust Fan section and Options/Accessories table.

- Occupied/Unoccupied mode with field furnished setback thermostat
- Demand Control Ventilation (DCV) ready using optional CO<sub>2</sub> sensors
- Mixed Air Sensor is furnished for field installation in the rooftop unit

**NOTE** - Sensor is factory installed when Economizers are factory installed.

- Single sensible sensor is furnished with Economizer and enables economizer operation if the outdoor temperature is less than the setpoint of the control
- Horizontal Barometric Dampers are required for horizontal Economizer applications and must be ordered separately

#### Standard Economizer Features

- Gear-driven action
- Return air and outdoor air dampers
- Plug-in connections to unit
- Neoprene seals
- 24-volt, fully-modulating spring return motor

#### Standard Economizer Control Module

- The Standard Economizer Control Module can be adjusted to operate based on outdoor air temperatures



#### Economizer Controls:

- Damper Minimum Position - Can be set lower than traditional minimum air requirements resulting in cost savings
- IAQ Sensor - Signals dampers to modulate and maintain 13°C when CO<sub>2</sub> is higher than the CO<sub>2</sub> setpoint
- Demand Control Ventilation (DCV) LED - A steady green Demand Control Ventilation LED indicates the IAQ reading is higher than setpoint and requires more fresh air
- Free Cool LED - A steady green LED indicates outdoor air is suitable for free cooling
- Free Cooling runs when outdoor air temperature is lower than the set temperature on the economizer control

**NOTE:** The Free Cooling default setting for outdoor air temperature sensor is 13°C.

#### High Performance Economizer Features

- Gear-driven action
- High torque 24-volt fully-modulating spring return damper motor
- Return air and outdoor air dampers
- Plug-in connections to unit
- Nylon bearings
- Enhanced thermoplastic vulcanizate (TPV) blade edge seals
- Flexible stainless steel jamb seals to minimize air leakage

#### High Performance Economizer Control Module

- Module provides inputs and outputs to control economizer based on parameter settings
- Module automatically detects sensors by polling to determine which sensors are installed in system
- Module displays any alarm messages (fault detection and diagnostics) as an aid in troubleshooting
- Non-volatile memory retains parameter settings in case of power failure
- Keypad with four navigation buttons and LCD screen is furnished for setting economizer parameters
  - Menu Up/Exit (↑) button returns to the main menu.
  - Arrow Up (▲) button moves to the previous or next parameter within the selected menu.
  - Arrow Down (▼) button moves to the next parameter within the selected menu.
  - Select (enter) (↵) button confirms parameter selection



## OPTIONS / ACCESSORIES

### **ECONOMIZER (continued)**

#### **Main Menu Structure:**

- **Status** (economizer and system operation status)
- **Setpoints** (settings for various setpoint parameters)
- **System Setup** (settings/information about the system)
- **Advanced Setup** (freeze protection, CO<sub>2</sub> settings, stage 3 delay and additional calibration settings)
- **Checkout** (damper positions)
- **Alarms** (output signal that can be configured for remote alarm monitoring)

**NOTE** - Refer to Installation Instructions for complete setup information and menu parameters available.

### **Factory or Field Installed**

#### **Single Enthalpy Temperature Control**

- Outdoor air enthalpy sensor enables Economizer if the outdoor enthalpy is less than the setpoint of the control

### **Field Installed**

#### **Differential Enthalpy Control**

- Order two Single Enthalpy Controls
- One is field installed in the return air section, the other in the outdoor air section
- Allows the economizer control board to select between outdoor air or return air, whichever has lower enthalpy

### **EXHAUST**

#### **Field Installed**

#### **Horizontal Barometric Relief Dampers**

- For use when unit is configured for horizontal applications with an economizer
- Allows relief of excess air
- Blade type dampers prevent blow back and outdoor air infiltration during off cycle
- Field installed in return air duct
- Exhaust hood with bird screen furnished

**NOTE** - Requires Horizontal Economizer Conversion Kit.

#### **Horizontal Economizer Conversion Kit**

- Insulated panel covers the bottom return air opening on the unit base to convert downflow Economizer to horizontal airflow

#### **Power Exhaust Fan**

- Installs internal to unit for downflow applications only with Economizer option
- Provides exhaust air pressure relief
- Interlocked to run when supply air blower is operating, fan runs when outdoor air dampers are 50% open (adjustable)
- Motor is overload protected
- Fan is 406 mm diameter
- 4 fan blades
- 0.25 kW motor

**NOTE** - If Power Exhaust is field installed with a factory installed Economizer, the Economizer must be ordered with No Exhaust option. Barometric Relief Dampers must also be ordered separately for field installation.

### **OUTDOOR AIR**

#### **Factory or Field Installed**

#### **Outdoor Air Dampers - Downflow or Horizontal**

- Single blade damper
- 0 to 25% (fixed) outdoor air adjustable
- Installs in unit
- Automatic model features fully modulating spring return damper motor with plug-in connection
- Manual model features a slide damper
- Maximum mixed air temperature in cooling mode: 38°C
- Outdoor Air Hood is furnished

### **ROOF CURBS**

- Nailer strip furnished, mates to unit, US National Roofing Contractors Approved, shipped knocked down

#### **Hybrid Roof Curbs, Downflow**

- Roof curbs can be assembled using interlocking tabs to fasten corners together; no tools required
- Curbs can also be fastened together with furnished hardware
- Available in 203, 356, 457, and 610 mm heights

#### **Full Perimeter Curbs, Downflow (090 Models Only)**

- Hybrid roof curbs can be assembled using interlocking tabs to fasten corners together; no tools required
- Hybrid roof curb can also be fastened together with furnished hardware. Available in 203, 356, 457 and 610 mm

**NOTE** - 090 models can be used on smaller 2026 mm Hybrid Roof Curbs (not full perimeter) with 400 mm overhang at condenser end of unit. See dimension drawing on page 48.

#### **Adjustable Pitch Curb**

- Fully adjustable pitch curb provides a level platform for rooftop units allowing flexible installations on roofs with uneven or sloped angles
- Maximum slope is 19 mm per 300 mm in any direction
- Uses interlocking tabs to fasten corners together
- No tools required
- Hardware is furnished to connect upper curb with lower curb
- Available in 356 mm height.

#### **Adaptor Curbs (not shown)**

- Curbs are regionally sourced
- Dimensions vary based upon the source

**NOTE** - Contact your local sales representative for a detailed cut sheet with applicable dimensions.



### **CEILING DIFFUSERS**

#### **Field Installed**

##### **Ceiling Diffusers (Flush or Step-Down)**

- White powder coat finish on diffuser face and grilles
- Insulated UL listed duct liner
- Diffuser box has collars for duct connection
- Step-down diffusers have double deflection blades
- Flush diffusers have fixed blades
- Provisions for suspending
- Internally sealed to prevent recirculation
- Removable return air grille
- Adapts to T-bar ceiling grids or plaster ceilings

##### **Transitions (Supply and Return)**

- Used with diffusers
- Installs in roof curb
- Galvanized steel construction
- Flanges furnished for duct connection to diffusers
- Fully insulated

## OPTIONAL CONVENTIONAL TEMPERATURE CONTROL SYSTEMS

### Comfortsense® 7500 Commercial 7-Day Programmable Thermostat



- Four-Stage Heating / Two-Stage Cooling
- Universal Multi-Stage
- Intuitive Touchscreen Interface
- Automatic Changeover between Heating and Cooling
- Full Seven-Day Programming
- Four Time Periods Per Day
- Temperature and Humidity Control
- One-Touch Away Mode
- Holiday Scheduling
- Smooth Setback Recovery (SSR)
- Performance Reports
- Notifications/Reminders
- Dehumidification/Humiditrol® Control for Split Systems and Rooftop Units
- Economizer Relay Control
- Backlit Display
- Wallplate Furnished
- FDD, ASHRAE and IECC Compliant

### Comfortsense® 3000 Commercial 5-2 Day Programmable Thermostat



- Two-Stage Heating / Two-Stage Cooling
- Conventional Systems
- Intuitive Interface
- 5-2 Day Programming
- Program Hold
- Remote Indoor Temperature Sensing
- Smooth Setback Recovery (SSR)
- Economizer Relay Control
- Maintenance/Filter/Service Reminders
- Backlit Display
- Wallplate Furnished
- Simple Up and Down Temperature Control

### BACnet Compatible Thermostat With Reheat Function



- 7-Day Programmable
- For units with or without Humiditrol®
- BTL listed MS/TP ensures compatibility with any BACnet system
- Built-in control programs for conventional and heat pump applications
- Conventional systems up to 3-stage heat and 3-stage cool
- Heat pumps with 1 or 2 compressors and up to 2-stage auxiliary heat
- On-board temperature and humidity sensor
- Multiple configurable inputs and outputs enable advanced control strategies
- Set-up Wizard enables rapid system configuration
- No special tools required for installation or commissioning
- Seven-day (2, 4 or 6 event) occupancy scheduling per day
- Backlit 5-inch LCD touchscreen

Description	Catalog No.
<b>ComfortSense® 7500 Commercial 7-Day Programmable Thermostat</b>	
CS7500 7-Day Thermostat	<b>17G74</b>
Sensors/	<sup>1</sup> Remote non-adjustable wall-mount 20k <b>47W36</b>
Accessories	<sup>1</sup> Remote non-adjustable wall-mount 10k <b>47W37</b>
	Remote non-adjustable discharge air (duct mount) <b>19L22</b>
	Outdoor temperature sensor <b>X2658</b>
<b>ComfortSense® 3000 5-2 Day Programmable</b>	
CS3000 5-2 Day Thermostat	<b>11Y05</b>
Sensor/	Remote non-adjustable wall mount 10k averaging <b>47W37</b>
Accessories	Thermostat wall mounting plate <b>X2659</b>
BACnet	<sup>2</sup> 7-Day BACnet Thermostat <b>Y8241</b>
Controls	<sup>3</sup> BACnet Module (factory or field) <b>16X70</b>
<sup>4</sup> BACnet	With Display <b>97W23</b>
Room Sensors	Without Display <b>97W24</b>
<b>Universal Thermostat Guard with Lock (clear)</b>	
	Inside Dimensions (H x W) 5 7/8 x 8 3/8 in. <b>39P21</b>

<sup>1</sup> Remote wall-mount sensors can be applied in any of the following combinations:  
 One Sensor - (1) 47W36, Two Sensors - (2) 47W37, Three Sensors - (2) 47W36 and (1) 47W37  
 Four Sensors - (4) 47W36, Five Sensors - (3) 47W36 and (2) 47W37

<sup>2</sup> BACnet Thermostat (Y8241) will control units with and without the Humiditrol® option. If there is a mix of units equipped with and without Humiditrol on the same site, this thermostat can be used for all units if suitable.

<sup>3</sup> Not compatible with units equipped with Humiditrol® option.

<sup>4</sup> Only compatible with BACnet Module (16X70).

## OPTIONS / ACCESSORIES

Item	Model No.	Catalog No.	Unit Model Number									
			KGB 036	KGB 048	KGB 060	KGB 072	KGB 074	KGB 090				
<b>COOLING SYSTEM</b>												
Condensate Drain Trap	Polyvinyl Chloride (PVC) - C1TRAP20AD2	22H54	X	X	X	X	X	X				
		76W27	X	X	X	X	X	X				
Conventional Fin/Tube Condenser Coil (replaces Environ™ Coil System)		Factory	O	O	O			<sup>1</sup> O	O			
Drain Pan Overflow Switch	K1SNSR71AB1-	74W42	X	X	X	X	X	X	X			
Low Ambient Kit	K1SNSR33AN2	14D89	X	X	X	X	X	X	X			
Efficiency	High						O	O				
		Standard	O	O	O			O	O			
Refrigerant Type		R-410A	O	O	O	O	O	O	O			
<b>HEATING SYSTEM</b>												
Bottom Gas Piping Kit	T1GPKT01AN1	19W50	X	X	X	X	X	X	X			
Low Temperature Vestibule Heater	T1CWKT01AN1G	19W54	X	X	X	X	X	X	X			
Combustion Air Intake Extensions	T1EXTN10AN1	19W51	X	X	X	X	X	X	X			
Gas Heat Input	Standard Gas Heat, 1 Stage - 16.7 kW	Factory	O	O	O	O	O	O	O			
	Medium Gas Heat, 1 Stage - 27.8 kW	Factory	O	O	O	O	O	O	O			
	Medium Gas Heat, 2 Stage - 20.8/ 27.8 kW	Factory	O	O	O	O	O	O	O			
	High Gas Heat, 1 Stage - 38.7 kW	Factory		O	O	O	O	O	O			
	High Gas Heat, 2 Stage - 29.0/38.7 kW	Factory		O	O	O	O	O	O			
LPG/Propane Conversion Kits	For one-stage models - C1PROP10AP3	21Z22	X	X	X	X	X	X	X			
	For two-stage models - C1PROP20AP3	21Z23	X	X	X	X	X	X	X			
Stainless Steel Heat Exchanger			O	O	O	O	O	O	O			
Vertical Vent Extension	C1EXTN20FF1	31W62	X	X	X	X	X	X	X			
<b>BLOWER - SUPPLY AIR</b>												
Motors	Belt Drive - 1.5 kW Standard Efficiency	Factory	O	O	O		<sup>2</sup> O		O			
	Belt Drive - 2.2 kW Standard Efficiency	Factory							O			
	Belt Drive - 1.2 kW (2 Speed)	Factory						O	O			
Drive Kits See Blower Data Tables for selection	Kit A01 - T1DRKT001-1 - 561 - 842 rev/min	Factory	O									
	Kit A02 - T1DRKT002-1 - 621 - 931 rev/min	Factory		O								
	Kit A03 - T1DRKT003-1 - 694 - 1042 rev/min	Factory			O							
	Kit A04 - T1DRKT004-1 - 807 - 1117 rev/min	Factory				<sup>2</sup> O		<sup>2,4</sup> O				
	Kit A05 - T1DRKT005-1 - 748 - 1122 rev/min	Factory	O									
	Kit A06 - T1DRKT006-1 - 893 - 1191 rev/min	Factory		O								
	Kit A07 - T1DRKT007-1 - 1010 - 1290 rev/min	Factory			O							
	Kit A08 - T1DRKT008-1 - 994 - 1326 rev/min	Factory				<sup>2</sup> O		<sup>2,4</sup> O				
	Kit A09 - T1DRKT009-1 - 1193 - 1594 rev/min	Factory				<sup>2</sup> O		<sup>2,4</sup> O				
	Kit AA02 - T1DRKT002AP1 - 527 - 729 rev/min	Factory				<sup>5</sup> O		<sup>3</sup> O	O			
Kit AA03 - T1DRKT003AP1 - 665 - 921 rev/min	Factory				<sup>5</sup> O		<sup>3</sup> O	O				
Kit AA04 - T1DRKT004AP1 - 768 - 1023 rev/min	Factory				<sup>5</sup> O		<sup>3</sup> O	O				
Kit AA05 - T1DRKT005AP1 - 921 - 1177 rev/min	Factory							O				
<b>CABINET</b>												
Combination Coil/Hail Guards	C1GARD51A-1	13R98	X	X								
	C1GARD51AT1	13T03			X	X	X					
	K1GARD50AP1	13T17							X			
Hinged Access Panels		Factory	O	O	O	O	O	O	O			
Corrosion Protection		Factory	O	O	O	O	O	O	O			

<sup>1</sup> 074S models only.

<sup>2</sup> 072S and 074S Single Speed Belt Drive models only.

<sup>3</sup> 074H Two-Speed Belt Drive models only.

<sup>4</sup> 074S Two-Speed Belt Drive models only.

<sup>5</sup> 072H Single Speed Belt Drive.

NOTE - The catalog and model numbers that appear here are for ordering field installed accessories only.

OX - Field Installed or Configure to Order (Factory installed)

O - Configure to Order (Factory Installed)

X - Field Installed.

## OPTIONS / ACCESSORIES

Item	Model No.	Catalog No.	Unit Model Number					
			KGB 036	KGB 048	KGB 060	KGB 072	KGB 074	KGB 090
<b>CONTROLS</b>								
<b>NOTE - Also see Conventional Thermostat Control Systems on page 43 for Additional Options.</b>								
Smoke Detector - Supply or Return (Power board and one sensor)	C1SNSR44AP1	21Z11	X	X	X	X	X	X
Smoke Detector - Supply and Return (Power board and two sensors)	C1SNSR43AP1	21Z12	X	X	X	X	X	X
<b>ECONOMIZER</b>								
<b>Standard Economizer With Outdoor Air Hood (Sensible Control)</b>								
Standard Economizer - Includes Barometric Relief Dampers and Exhaust Hood	K1ECON30A-3-	14D90	OX	OX	OX	OX	OX	OX
Standard Economizer - No Exhaust		Factory	O	O	O	O	O	O
<b>Standard Economizer Controls</b>								
Single Enthalpy Control	C1SNSR64FF1	21Z09	OX	OX	OX	OX	OX	OX
Differential Enthalpy Control (order 2)	C1SNSR64FF1	21Z09	X	X	X	X	X	X
<b>High Performance Economizer With Outdoor Air Hood (Sensible Control)</b>								
High Performance Economizer - Includes Barometric Relief Dampers and Exhaust Hood	K1ECON32A-4	20H49	OX	OX	OX	OX	OX	OX
<b>High Performance Economizer Controls</b>								
Single Enthalpy Control	C1SNSR60FF1	10Z75	OX	OX	OX	OX	OX	OX
Differential Enthalpy Control (order 2)	C1SNSR60FF1	10Z75	X	X	X	X	X	X
<b>Economizer Accessories</b>								
Horizontal Economizer Conversion Kit	T1HECK00AN1	17W45	X	X	X	X	X	X
<b>POWER EXHAUST FAN</b>								
Standard Static <i>NOTE - Field installed Power Exhaust Fan requires "Barometric Relief Dampers for Power Exhaust Kit" for field installation. See below.</i>	380/420V-3ph - C1PWRE10A-1M	21Z16	X	X	X	X	X	X
<b><sup>1</sup> BAROMETRIC RELIEF</b>								
<sup>1</sup> Barometric Relief Dampers for Power Exhaust Kit	C1DAMP50A-3-	21Z21	X	X	X	X	X	X
<sup>2</sup> Horizontal Barometric Relief Dampers With Exhaust Hood	LAGEDH03/15-2	19F01	X	X	X	X	X	X
<b>OUTDOOR AIR</b>								
<b>Outdoor Air Dampers - Includes Outdoor Air Hood</b>								
Motorized	C1DAMP21A-1	15D17	OX	OX	OX	OX	OX	OX
Manual	C1DAMP11A-2	15D18	OX	OX	OX	OX	OX	OX
<b>ELECTRICAL</b>								
Voltage 50 Hz with neutral	380/420V - 3 phase		O	O	O	O	O	O

<sup>1</sup> Required when Economizer is factory installed with field installed Power Exhaust Fan option.

<sup>2</sup> Required when Economizer is configured for horizontal airflow.

NOTE - The catalog and model numbers that appear here are for ordering field installed accessories only.

OX - Field Installed or Configure to Order (Factory installed)

O - Configure to Order (Factory Installed)

X - Field Installed.

## OPTIONS / ACCESSORIES

Item	Model No.	Catalog No.	Unit Model Number										
			KGB 036	KGB 048	KGB 060	KGB 072	KGB 074	KGB 090					
<b>INDOOR AIR QUALITY</b>													
<b>Air Filters</b>													
Healthy Climate® High Efficiency Air Filters	MERV 8 (406 x 508 x 51) - C1FLTR15A-1-	<b>54W20</b>	X	X									
	MERV 13 (406 x 508 x 51) - T1FLTR40A-1-	<b>52W37</b>	X	X									
Order 4 per unit	MERV 8 (508 x 508 x 51) - C1FLTR15D-1-	<b>54W21</b>			X	X	X	X	X	X			
	MERV 13 (508 x 508 x 51) - C1FLTR40D-1-	<b>52W39</b>			X	X	X	X	X	X			
<b>Indoor Air Quality (CO<sub>2</sub>) Sensors</b>													
Sensor - Wall-mount, off-white plastic cover with LCD display	C0SNSR50AE1L	<b>77N39</b>	X	X	X	X	X	X	X	X			
Sensor - Wall-mount, black plastic case, no display, rated for plenum mounting	C0SNSR53AE1L	<b>87N54</b>	X	X	X	X	X	X	X	X			
CO <sub>2</sub> Sensor Duct Mounting Kit - for downflow applications	C0MISC19AE1-	<b>85L43</b>	X	X	X	X	X	X	X	X			
Aspiration Box - for duct mounting non-plenum rated CO <sub>2</sub> sensor ( <b>77N39</b> )	C0MISC16AE1-	<b>90N43</b>	X	X	X	X	X	X	X	X			
<b>UVC Germicidal Lamps</b>													
<sup>1</sup> Healthy Climate® UVC Light Kit (220V-1ph)	E1UVCL10AN1-	<b>21A92</b>	X	X	X	X	X	X	X	X			
<b>ROOF CURBS</b>													
<b>Hybrid Roof Curbs, Downflow</b>													
203 mm height	C1CURB70A-1	<b>11F50</b>	X	X	X	X	X	X	X	X	<sup>2</sup> X		
356 mm height	C1CURB71A-1	<b>11F51</b>	X	X	X	X	X	X	X	X	<sup>2</sup> X		
457 mm height	C1CURB72A-1	<b>11F52</b>	X	X	X	X	X	X	X	X	<sup>2</sup> X		
610 mm height	C1CURB73A-1	<b>11F53</b>	X	X	X	X	X	X	X	X	<sup>2</sup> X		
<b>Hybrid Roof Curbs, Full Perimeter, Downflow</b>													
203 mm height	K1CURB70AP1	<b>11S47</b>									X		
356 mm height	K1CURB71AP1	<b>11S48</b>									X		
457 mm height	K1CURB72AP1	<b>11T01</b>									X		
610 mm height	K1CURB73AP1	<b>11T06</b>									X		
<b>Adjustable Pitch Curb, Downflow</b>													
356 mm height	C1CURB55AT1	<b>43W27</b>	X	X	X	X	X	X	X	X	<sup>2</sup> X		
<b>CEILING DIFFUSERS</b>													
Step-Down - Order one	RTD9-65S	<b>13K60</b>	X	X	X								
	RTD11-95S	<b>13K61</b>					X	X	X				
Flush - Order one	FD9-65S	<b>13K55</b>	X	X	X								
	FD11-95S	<b>13K56</b>					X	X	X				
Transitions (Supply and Return) - Order one	T1TRAN10AN1	<b>17W53</b>	X	X	X								
	T1TRAN20N-1	<b>17W54</b>					X	X	X				

<sup>1</sup> Lamps operate on 220V single-phase power supply. Step-down transformer must be field supplied for field installation for 380/420V primary to 220V secondary. Alternately, a separate 220V power supply may be used to directly power the UVC ballast(s).

<sup>2</sup> 090 models will fit smaller roof curbs with overhang. See dimension drawing.

NOTE - The catalog and model numbers that appear here are for ordering field installed accessories only.

OX - Field Installed or Configure to Order (Factory installed)

O - Configure to Order (Factory Installed)

X - Field Installed.

SPECIFICATIONS		10.5 - 17.5 KW		
General Data	Nominal Size	10.5 kW (3 Ton)	14.0 kW (4 Ton)	17.5 kW (5 Ton)
	Model No.	KGB036S4B	KGB048S4B	KGB060S4B
	Efficiency Type	Standard	Standard	Standard
	Blower Type	Single Speed Belt Drive	Single Speed Belt Drive	Single Speed Belt Drive
Cooling Performance	Gross Cooling Capacity - kW (Btuh)	9.5 (32 300)	12.6 (42 900)	15.8 (53 800)
	<sup>1</sup> Net Cooling Capacity - kW (Btuh)	9.1 (31 000)	12.0 (40 800)	15.0 (51 300)
	AHRI Rated Air Flow - L/s (cfm)	542 (1150)	736 (1560)	830 (1760)
	<sup>3</sup> Sound Rating Number (dB)	74	74	79
	Total Unit Power - kW	2.5	3.5	4.2
	<sup>1</sup> SEER (Btuh/Watt)	14.0	14.0	14.0
	<sup>1</sup> EER (Btuh/Watt) at 35°C (95° F)	12.5	11.6	12.0
	<sup>2</sup> EER (Btuh/Watt) at 46°C (115°F)	8.4	7.8	8.4
Refrigerant Charge	Refrigerant Type	R-410A	R-410A	R-410A
	Environ™ Coil System	2.52 kg (5 lbs. 9 oz)	2.55 kg (5lbs. 10 oz)	3.09 kg (6 lbs. 13 oz.)
	Conventional Fin/Tube Coil	4.99 kg (11 lbs. 3 oz.)	4.45 kg (9 lbs. 13 oz.)	6.46 kg (14 lbs. 4 oz.)
Gas Heating Options - See page 18		Standard (1 Stage) Medium (1 or 2 Stage)	Standard (1 Stage) Medium (1 or 2 Stage) High (1 or 2 Stage)	
Compressor Type (one per unit)		Scroll	Scroll	Scroll
Outdoor Coil Environ™ (Fin/Tube)	Net face area - m <sup>2</sup> (sq. ft.)	1.35 (14.5) / 1.45 (15.6)	1.35 (14.5) / 1.45 (15.6)	1.65 (17.8) / 1.79 (19.3)
	Number of rows	1 (2)	1 (2)	1 (2)
	Fins per meter (Fins per inch)	905 (23) / 787 (20)	905 (23) / 787 (20)	905 (23) / 787 (20)
Outdoor Coil Fan	Motor W (hp)	187 (1/4)	187 (1/4)	249 (1/3)
	Motor rev/min	690	705	900
	Total motor watts	247	247	284
	Diameter - mm (in.) / No. of blades	610 (24) - 4	610 (24) - 4	610 (24) - 3
	Total air volume - L/s (cfm)	1554 (3292)	1554 (3292)	1850 (3920)
Indoor Coil	Net face area - m <sup>2</sup> (sq. ft.)	0.7 (7.8)	0.7 (7.8)	0.9 (9.7)
	Tube diameter - in. (mm)	9.5 (3/8)	9.5 (3/8)	9.5 (3/8)
	Number of rows	3	3	4
	Fins per meter (Fins per inch)	551 (14)	551 (14)	551 (14)
	Drain Connection (no.and size) - in.	(1) 1 NPT	(1) 1 NPT	(1) 1 NPT
	Expansion device type	Balanced Port Thermostatic Expansion Valve, removable power head		
<sup>4</sup> Indoor Blower & Drive Selection	Nominal Motor Size kW (hp)	1.5 (2)	1.5 (2)	1.5 (2)
	Maximum Usable Motor Size kW (hp)	1.7 (2.3)	1.7 (2.3)	1.7 (2.3)
	Drive Kit (rev/min range)	<b>A01</b> - (561 - 842) <b>A05</b> - (748 - 1122)	<b>A02</b> - (621 - 931) <b>A06</b> - (893 - 1191)	<b>A03</b> - (694 - 1042) <b>A07</b> - (1010 - 1290)
	Wheel nominal diameter x width - mm (in.)	254 x 254 (10 x 10)		
Filters	Type	Disposable		
	Number and size - mm (in.)	(4) 406 x 508 x 51 (16 x 20 x 2)	(4) 406 x 508 x 51 (16 x 20 x 2)	(4) 508 x 508 x 51 (20 x 20 x 2)
Electrical Characteristics - 50 Hz		380/420V - 50 hertz - 3 phase with neutral		

NOTE - Net capacity includes evaporator blower motor heat deduction. Gross capacity does not include evaporator blower motor heat deduction.

<sup>1</sup> Tested at conditions which are based on AHRI Standard 210/240; 35°C (95°F) outdoor air temperature and 27°C (80°F) dry bulb/19°C (67°F) wet bulb entering evaporator air; minimum external duct static pressure while operating at rated voltage and air volumes.

<sup>2</sup> Rated at 46°C (115°F) outdoor air temperature and 27°C (80°F) db/19°C (67°F) wb entering evaporator air (T3 Conditions).

<sup>3</sup> Sound Rating Number rated in accordance with test conditions included in AHRI Standard 270.

<sup>4</sup> Using total air volume and system static pressure requirements determine from blower performance tables rev/min and motor size required. Maximum usable size of motors furnished is shown. If motors of comparable size are used, be sure to keep within the service factor limitations outlined on the motor nameplate.



**SPECIFICATIONS**

**21 KW**

General Data		Nominal Tonnage	21 kW (6 Ton)	21 kW (6 Ton)
		Model No.	<b>KGB072H4B</b>	<b>KGB074S4B</b>
		Efficiency Type	<b>High</b>	<b>Standard</b>
		Blower Type	Single Speed Belt Drive	Single Speed Belt Drive
<b>Cooling Performance</b>	Gross Cooling Capacity - kW (Btuh)		18.6 (63 600)	18.0 (61 500)
	<sup>1</sup> Net Cooling Capacity - kW (Btuh)		18.3 (62 300)	17.3 (58 900)
	Rated Air Flow - (L/s) cfm		906 (1920)	991 (2100)
	<sup>3</sup> Sound Rating Number (dB)		79	79
	Total Unit Power - kW		5.1	5.2
	<sup>1</sup> IEER (Btuh/Watt)		13.5	13.0
	<sup>1</sup> EER (Btuh/Watt) at 35°C (95°F)		12.2	11.3
<sup>2</sup> EER (Btuh/Watt) at 46°C (115°F)		8.3	8.0	
<b>Refrigerant Charge</b>	Refrigerant Type		R-410A	R-410A
	Environ™ Coil System		3.4 kg (7 lbs. 8 oz.)	3.23 kg (7 lbs. 2 oz.)
	Conventional Fin/Tube Coil		- - -	6.58 kg (14 lbs. 8 oz.)
<b>Gas Heating Options - See page 18</b>			<b>Standard (1 Stage), Medium (1 or 2 Stage), High (1 or 2 Stage)</b>	
<b>Compressor Type (one per unit)</b>			Scroll	Two-Stage Scroll (1)
<b>Outdoor Coil Environ™ (Fin/Tube)</b>	Net face area - m <sup>2</sup> (sq. ft.)		1.65 (17.8)	1.65 (17.8) / 1.79 (19.3)
	Number of rows		1	1 (2)
	Fins per meter (Fins per inch)		905 (23)	905 (23) / 787 (20)
<b>Outdoor Coil Fan</b>	Motor W (hp)		(1) 249 (1/3)	(1) 249 (1/3)
	Motor rev/min		900	900
	Total motor watts		310	284
	Diameter - mm (in.) / No. of blades		(1) 610 (24) - 3	(1) 610 (24) - 3
	Total air volume - L/s (cfm)		1888 (4000)	1850 (3920)
<b>Indoor Coil</b>	Net face area - m <sup>2</sup> (sq. ft.)		0.9 (9.72)	0.9 (9.72)
	Tube diameter - mm (in.)		9.5 (3/8)	9.5 (3/8)
	Number of rows		4	4
	Fins per meter (Fins per inch)		551 (14)	551 (14)
	Drain Connection (no.and size) - in.		(1) 1 NPT	(1) 1 NPT
	Expansion device type		Balanced Port Thermostatic Expansion Valve, removable power head	
<sup>4</sup> <b>Indoor Blower &amp; Drive Selection</b>	Nominal Motor kW (hp)		1.5 (2)	1.5 (2)
	Maximum usable motor kW (hp)		1.7 (2.3)	1.7 (2.3)
	Drive Kit (rev/min range)		<b>AA02</b> - (527 - 729) <b>AA03</b> - (665 - 921) <b>AA04</b> - (768 - 1023)	<b>A08</b> (994 - 1326) <b>A09</b> (1193 - 1594)
	Wheel nominal diameter x width - mm (in.)		381 x 229 (15 x 9)	254 x 254 (10 x 10)
<b>Filters</b>	Type		Disposable	
	Number and size - mm (in.)		(4) 508 x 508 x 51 (20 x 20 x 2)	(4) 508 x 508 x 51 (20 x 20 x 2)
<b>Electrical Characteristics - 50 Hz</b>			380/420V - 50 hertz - 3 phase with neutral	

NOTE - Net capacity includes evaporator blower motor heat deduction. Gross capacity does not include evaporator blower motor heat deduction.

<sup>1</sup> Tested at conditions which are based on AHRI Standard 340/360; 35°C (95°F) outdoor air temperature and 27°C (80°F) dry bulb/19°C (67°F) wet bulb entering evaporator air; minimum external duct static pressure while operating at rated voltage and air volumes.

<sup>2</sup> Rated at 46°C (115°F) outdoor air temperature and 27°C (80°F) db/19°C (67°F) wb entering evaporator air (T3 Conditions).

<sup>3</sup> Sound Rating Number rated in accordance with test conditions included in AHRI Standard 270.

<sup>4</sup> Using total air volume and system static pressure requirements determine from blower performance tables rev/min and motor size required. Maximum usable size of motors furnished is shown. If motors of comparable size are used, be sure to keep within the service factor limitations outlined on the motor nameplate.

**SPECIFICATIONS**
**21 KW**

General Data		Nominal Size	21 kW (6 Ton)	21 kW (6 Ton)
		Model No.	KGB074H4T	KGB074S4T
		Efficiency Type	High	Standard
		Blower Type	Two Speed Belt Drive	Two Speed Belt Drive
Cooling Performance	Gross Cooling Capacity - kW (Btuh)		18.3 (62 300)	18.0 (61 500)
	<sup>1</sup> Net Cooling Capacity - kW (Btuh)		17.5 (59 700)	17.3 (58 900)
	ARI Rated Air Flow - L/s (cfm)		991 (2100)	991 (2100)
	<sup>3</sup> Sound Rating Number (dB)		79	79
	Total Unit Power - kW		4.9	5.2
	<sup>1</sup> IEER (Btuh/Watt)		8.3	15.0
	<sup>1</sup> EER (Btuh/Watt) at 35°C (95°F)		16.2	11.3
<sup>2</sup> EER (Btuh/Watt) at 46°C (115°F)		12.2	8.0	
Refrigerant Charge	Refrigerant Type		R-410A	R-410A
	Environ™ Coil System		3.23 kg (7 lbs. 2 oz.)	3.23 kg (7 lbs. 2 oz.)
	Conventional Fin/Tube Coil		- - -	6.58 kg (14 lbs. 8 oz.)
Gas Heating Options - See page 18			Medium (1 or 2 stage) or High (1 or 2 stage)	Standard (1 stage) or Medium (1 or 2 stage)
Compressor Type (one per unit)			Two-Stage Scroll (1)	Two-Stage Scroll (1)
Outdoor Coil Environ™ (Fin/Tube)	Net face area - m <sup>2</sup> (sq. ft.)		1.65 (17.8)	1.65 (17.8) / 1.79 (19.3)
	Number of rows		1	1 (2)
	Fins per meter (Fins per inch)		905 (23)	905 (23) / 787 (20)
Outdoor Coil Fan	Motor W (hp)		(1) 249 (1/3)	(1) 249 (1/3)
	Motor rev/min		900	900
	Total motor watts		284	284
	Diameter - mm (in.) / No. of blades		(1) 610 (24) - 3	(1) 610 (24) - 3
	Total air volume - L/s (cfm)		1848 (3900)	1848 (3900)
Indoor Coil	Net face area - m <sup>2</sup> (sq. ft.)		0.9 (9.72)	0.9 (9.72)
	Tube diameter - mm (in.)		9.5 (3/8)	9.5 (3/8)
	Number of rows		4	4
	Fins per meter (Fins per inch)		551 (14)	551 (14)
	Drain Connection (no.and size) - in.		(1) 1 NPT	(1) 1 NPT
	Expansion device type		Balanced Port Thermostatic Expansion Valve, removable power head	
<sup>4</sup> Indoor Blower & Drive Selection	Nominal Motor Size kW (hp)		1.2 (1.7)	1.2 kW (1.7 hp)
	Maximum Usable Motor Size kW (hp)		1.4 (1.9)	1.4 kW (1.9 hp)
	Drive Kit (rev/min range)		AA02 - (527 - 729) AA03 - (665 - 921) AA04 - (768 - 1023)	A04 - (807 - 1117) A08 - (994 - 1326)
	Wheel nominal diameter x width - mm (in.)		381 x 229 (15 x 9)	254 x 254 x (10 x 10)
Filters	Type		Disposable	
	Number and size - mm (in.)		(4) 508 x 508 x 51 (20 x 20 x 2)	(4) 508 x 508 x 51 (20 x 20 x 2)
Electrical Characteristics - 50 Hz			380/420V - 50 hertz - 3 phase with neutral	

NOTE - Net capacity includes evaporator blower motor heat deduction. Gross capacity does not include evaporator blower motor heat deduction.

<sup>1</sup> Tested at conditions which are based on AHRI Standard 340/360; 35°C (95°F) outdoor air temperature and 27°C (80°F) dry bulb/19°C (67°F) wet bulb entering evaporator air; minimum external duct static pressure while operating at rated voltage and air volumes.

<sup>2</sup> Rated at 46°C (115°F) outdoor air temperature and 27°C (80°F) db/19°C (67°F) wb entering evaporator air (T3 Conditions).

<sup>3</sup> Sound Rating Number rated in accordance with test conditions included in AHRI Standard 270.

<sup>4</sup> Using total air volume and system static pressure requirements determine from blower performance tables rev/min and motor size required. Maximum usable size of motors furnished is shown. If motors of comparable size are used, be sure to keep within the service factor limitations outlined on the motor nameplate.

**SPECIFICATIONS**

**26.4 KW**

General Data		Nominal Size	26.4 kW (7.5 Ton)	26.4 kW (7.5 Ton)
		Model No.	KGB090S4T	KGB090S4B
		Efficiency Type	Standard	Standard
		Blower Type	Two Speed Belt Drive	Single Speed Belt Drive
Cooling Performance	Gross Cooling Capacity - kW (Btuh)		23.1 (79 000)	23.1 (79 000)
	<sup>1</sup> Net Cooling Capacity - kW (Btuh)		22.4 (76 500)	22.4 (76 500)
	ARI Rated Air Flow - L/s (cfm)		2225	2225
	<sup>3</sup> Sound Rating Number (dB)		79	79
	Total Unit Power - kW		6.8	6.8
	<sup>1</sup> IEER (Btuh/Watt)		8.1	8.1
	<sup>1</sup> EER (Btuh/Watt) at 35°C (95°F)		14.0	13.0
	<sup>2</sup> EER (Btuh/Watt) at 46°C (115°F)		11.3	11.3
Refrigerant Charge	Refrigerant Type		R-410A	R-410A
	Environ™ Coil System		4.19 kg (9 lbs. 4 oz.)	4.19 kg (9 lbs. 4 oz.)
	Conventional Fin/Tube Coil		8.11 kg (17 lbs. 14 oz.)	8.11 kg (17 lbs. 14 oz.)
Gas Heating Options - See page 18			Medium (1 or 2 stage) or High (1 or 2 stage)	
Compressor Type (one per unit)			Two-Stage Scroll (1)	Two-Stage Scroll (1)
Outdoor Coil Environ™ (Fin/Tube)	Net face area - m <sup>2</sup> (sq. ft.)		2.25 (24.2) / 2.57 (27.7)	2.25 (24.2) / 2.57 (27.7)
	Number of rows		1 (2)	1 (2)
	Fins per meter (Fins per inch)		905 (23) / 787 (20)	905 (23) / 787 (20)
	Motor W (hp)		374 (1/2)	(1) 374 (1/2)
Outdoor Coil Fan	Motor rev/min		900	900
	Total motor watts		433	433
	Diameter - mm (in.) / No. of blades		610 (24) - 4	(1) 610 (24) - 4
	Total air volume - L/s (cfm)		2085 (4420)	2085 (4420)
	Net face area - m <sup>2</sup> (sq. ft.)		0.9 (9.7)	0.90 (9.7)
Indoor Coil	Tube diameter - mm (in.)		9.5 (3/8)	9.5 (3/8)
	Number of rows		4	4
	Fins per meter (Fins per inch)		551 (14)	551 (14)
	Drain Connection (no. and size) - in.		(1) 1 in. NPT	(1) 1 NPT
	Expansion device type		Balanced Port Thermostatic Expansion Valve, removable power head	
	<sup>4</sup> Indoor Blower & Drive Selection	Nominal Motor Size kW (hp)		1.2 (1.7)
Maximum Usable Motor Size kW (hp)			1.4 (1.9)	1.7 kW (2.3 hp)
Drive Kit (rev/min range)			AA02 - (527 - 729) AA03 - (665 - 921) AA04 - (768 - 1023)	AA02 - (527 - 729) AA03 - (665 - 921) AA04 - (768 - 1023) AA05 - (921 - 1177)
Nominal Motor Size kW (hp)			---	2.2 kW (3 hp)
Maximum Usable Motor Size kW (hp)			---	2.57 kW (3.45 hp)
Drive Kit (rev/min range)			---	AA05 (921 - 1177)
Wheel nominal diameter x width - mm (in.)			---	381 x 229 (15 x 9)
Filters		Type		Disposable
	Number and size - mm (in.)		(4) 508 x 508 x 51 (20 x 20 x 2)	(4) 508 x 508 x 51 (20 x 20 x 2)
Electrical Characteristics - 50 Hz			380/420V - 50 hertz - 3 phase with neutral	

NOTE - Net capacity includes evaporator blower motor heat deduction. Gross capacity does not include evaporator blower motor heat deduction.

<sup>1</sup> Tested at conditions which are based on AHRI Standard 340/360; 35°C (95°F) outdoor air temperature and 27°C (80°F) dry bulb/19°C (67°F) wet bulb entering evaporator air; minimum external duct static pressure while operating at rated voltage and air volumes.

<sup>2</sup> Rated at 46°C (115°F) outdoor air temperature and 27°C (80°F) db/19°C (67°F) wb entering evaporator air (T3 Conditions).

<sup>3</sup> Sound Rating Number rated in accordance with test conditions included in AHRI Standard 270.

<sup>4</sup> Using total air volume and system static pressure requirements determine from blower performance tables rev/min and motor size required. Maximum usable size of motors furnished is shown. If motors of comparable size are used, be sure to keep within the service factor limitations outlined on the motor nameplate.

## SPECIFICATIONS - GAS HEAT

Model No.	036, 048, 060, 072, 074	036, 048, 060, 072, 074	090	036, 048, 060, 072, 074	090	048, 060, 072, 074	090	048, 060, 072, 074	090	
Heat Input Type	Standard (1 Stage)	Medium (1 Stage)		Medium (2 Stage)		High (1 Stage)		High (2 Stage)		
Input kW (Btuh)	1st Stage	16.7 (57 000)	27.8 (95 000)		20.8 (71 000)		38.7 (132 000)		29.0 (99 000)	
	2nd Stage	---	---		27.8 (95 000)		---		38.7 (132 000)	
Output kW (Btuh)	1st Stage	13.5 (46 000)	22.3 (76 000)		16.7 (57 000)		31.1 (106 000)		23.2 (79 000)	
	2nd Stage	---	---		22.3 (76 000)		---		31.1 (106 000)	
Temperature Rise Range	1st stage	6 - 22°C (10 - 40°F)	14 - 36°C (25 - 65°F)	6 - 22°C (10 - 40°F)	11 - 28°C (20 - 50°F)	3 - 19°C (5 - 35°F)	22 - 39°C (40 - 70°F)	11 - 28°C (20 - 50°F)	14 - 31°C (25 - 55°F)	6 - 22°C (10 - 40°F)
	2nd Stage	---	---	---	14 - 36°C (25 - 65°F)	6 - 22°C (10 - 40°F)	---	---	22 - 39°C (40 - 70°F)	11 - 28°C (20 - 50°F)
<sup>1</sup> Thermal Efficiency		80%	80%	80%	80%	80%	80%	80%	80%	80%
Gas Supply Connections	1/2 in. NPT									
Recommended Gas Supply Pressure - Natural/ LPG	1.7 kPa (7.0 in. w.c.) / 2.7 kPa (11.0 in. w.c.)									

<sup>1</sup> Thermal Efficiency at full input.

## HIGH ALTITUDE DERATE

NOTE - Units may be installed at altitudes up to 610 m (2000 ft) above sea level without any modifications. At altitudes above 610 m (2000 ft.), units must be derated to match information in the table shown. At altitudes above 1372 m (4500 ft.), unit must be derated 2% for each 305 m (1000 ft.) above sea level.

NOTE - This is the only permissible derate for these units.

Heat Input Type	Altitude Feet		Gas Manifold Pressure				Input Rate	
			kPa		in. w.g.			
	Meters	Feet	Natural Gas	LPG/ Propane	Natural Gas	LPG/ Propane	kW	Btuh
Standard (1 stage)	610 - 1372	2001 - 4500	0.58	1.73	2.3	6.9	15.5	53 000
Medium (1 stage)	610 - 1372	2001 - 4500	0.58	1.73	2.3	6.9	25.8	88 000
Medium (2 stage)	610 - 1372	2001 - 4500	0.58 / 0.33	1.73 / 0.98	2.3 / 1.3	6.9 / 3.9	25.8 / 19.3	88 000 / 66 000
High (1 stage)	610 - 1372	2001 - 4500	0.58	1.73	2.3	6.9	35.8	122 000
High (2 stage)	610 - 1372	2001 - 4500	0.58 / 0.33	1.73 / 0.98	2.3 / 1.3	6.9 / 3.9	35.8 / 27.0	122 000 / 92 000

# RATINGS

NOTE - For Temperatures and Capacities not shown in tables, see bulletin - Cooling Unit Rating Table Correction Factor Data in Miscellaneous Engineering Data section.

## 10.5 KW - KGB036S4

Entering Wet Bulb Temperature	Total Air Volume	Outdoor Air Temperature Entering Outdoor Coil																			
		26.7°C					35°C					43.3°C					46°C				
		Total Cool Cap.	Comp. Motor Input	Sensible To Total Ratio (S/T)			Total Cool Cap.	Comp. Motor Input	Sensible To Total Ratio (S/T)			Total Cool Cap.	Comp. Motor Input	Sensible To Total Ratio (S/T)			Total Cool Cap.	Comp. Motor Input	Sensible To Total Ratio (S/T)		
				Dry Bulb					Dry Bulb					Dry Bulb					Dry Bulb		
L/s	kW	kW	24°C	27°C	29°C	kW	kW	24°C	27°C	29°C	kW	kW	24°C	27°C	29°C	kW	kW	24°C	27°C	29°C	
17.2°C	455	9.6	1.57	0.73	0.9	1	8.7	1.9	0.75	0.94	1	7.7	2.35	0.77	0.99	1	7.4	2.53	0.8	1	1
	565	10.1	1.58	0.8	1	1	9.3	1.91	0.82	1	1	8.4	2.35	0.86	1	1	8.1	2.53	0.9	1	1
	680	10.8	1.59	0.87	1	1	9.9	1.92	0.91	1	1	8.9	2.35	0.97	1	1	8.6	2.53	0.99	1	1
19.4°C	455	10.3	1.58	0.56	0.71	0.86	9.3	1.91	0.56	0.73	0.9	8.4	2.35	0.57	0.75	0.95	8	2.53	0.58	0.78	0.97
	565	10.8	1.59	0.6	0.78	0.97	9.8	1.92	0.61	0.8	1	8.8	2.35	0.62	0.84	1	8.4	2.53	0.64	0.87	1
	680	11.1	1.6	0.64	0.85	1	10.1	1.92	0.65	0.89	1	9.1	2.36	0.67	0.94	1	8.7	2.53	0.7	0.96	1
21.7°C	455	10.9	1.59	0.41	0.55	0.69	10	1.92	0.4	0.56	0.7	9	2.35	0.39	0.56	0.72	8.6	2.53	0.39	0.58	0.75
	565	11.5	1.6	0.43	0.6	0.76	10.4	1.93	0.43	0.6	0.77	9.4	2.36	0.42	0.62	0.8	9	2.52	0.42	0.63	0.85
	680	11.8	1.62	0.45	0.64	0.83	10.8	1.94	0.45	0.65	0.86	9.7	2.36	0.44	0.67	0.91	9.3	2.53	0.45	0.69	0.94
Entering Wet Bulb Temperature	Total Air Volume	Outdoor Air Temperature Entering Outdoor Coil																			
		48°C					50°C					51.7°C									
		Total Cool Cap.	Comp. Motor Input	Sensible To Total Ratio (S/T)			Total Cool Cap.	Comp. Motor Input	Sensible To Total Ratio (S/T)			Total Cool Cap.	Comp. Motor Input	Sensible To Total Ratio (S/T)			Total Cool Cap.	Comp. Motor Input	Sensible To Total Ratio (S/T)		
				Dry Bulb					Dry Bulb					Dry Bulb					Dry Bulb		
L/s	kW	kW	24°C	27°C	29°C	kW	kW	24°C	27°C	29°C	kW	kW	24°C	27°C	29°C	kW	kW	24°C	27°C	29°C	
17.2°C	455	7.2	2.69	0.79	1	1	7	2.86	0.8	1	1	6.8	3.03	0.81	1	1					
	565	7.9	2.68	0.9	1	1	7.6	2.85	0.92	1	1	7.4	3.02	0.93	1	1					
	680	8.4	2.68	1	1	1	8.1	2.84	1	1	1	7.9	3	1	1	1					
19.4°C	455	7.7	2.68	0.57	0.76	0.98	7.4	2.87	0.57	0.77	1	7.2	3.02	0.58	0.78	1					
	565	8.1	2.68	0.62	0.87	1	7.8	2.86	0.63	0.88	1	7.6	3.01	0.64	0.9	1					
	680	8.4	2.68	0.69	0.97	1	8.1	2.85	0.69	0.99	1	7.9	3	0.7	1	1					
21.7°C	455	8.4	2.68	0.38	0.56	0.74	8.1	2.85	0.37	0.56	0.74	7.8	3.01	0.37	0.56	0.75					
	565	8.8	2.67	0.41	0.62	0.84	8.4	2.84	0.41	0.63	0.85	8.2	3	0.4	0.63	0.87					
	680	9.1	2.67	0.44	0.68	0.94	8.7	2.84	0.44	0.69	0.96	8.5	3	0.44	0.7	0.98					

# RATINGS

NOTE - For Temperatures and Capacities not shown in tables, see bulletin - Cooling Unit Rating Table Correction Factor Data in Miscellaneous Engineering Data section.

## 14.0 KW - KGB048S4

Entering Wet Bulb Temperature	Total Air Volume	Outdoor Air Temperature Entering Outdoor Coil																			
		26.7°C					35°C					43.3°C					46°C				
		Total Cool Cap.	Comp. Motor Input	Sensible To Total Ratio (S/T)			Total Cool Cap.	Comp. Motor Input	Sensible To Total Ratio (S/T)			Total Cool Cap.	Comp. Motor Input	Sensible To Total Ratio (S/T)			Total Cool Cap.	Comp. Motor Input	Sensible To Total Ratio (S/T)		
				Dry Bulb					Dry Bulb					Dry Bulb					Dry Bulb		
L/s	kW	kW	24°C	27°C	29°C	kW	kW	24°C	27°C	29°C	kW	kW	24°C	27°C	29°C	kW	kW	24°C	27°C	29°C	
17.2°C	605	12.7	2.23	0.71	0.9	1	11.3	2.69	0.73	0.96	1	9.9	3.25	0.76	1	1	9.5	3.45	0.81	1	1
	755	13.4	2.24	0.78	1	1	12	2.71	0.81	1	1	10.7	3.27	0.87	1	1	10.3	3.47	0.92	1	1
	905	14.1	2.25	0.86	1	1	12.7	2.72	0.91	1	1	11.3	3.29	0.98	1	1	10.8	3.49	1	1	1
19.4°C	605	13.5	2.24	0.55	0.69	0.85	12.1	2.71	0.55	0.72	0.91	10.6	3.26	0.56	0.74	0.97	10.1	3.47	0.58	0.79	1
	755	14.2	2.25	0.59	0.76	0.98	12.6	2.72	0.6	0.79	1	11.1	3.28	0.61	0.84	1	10.6	3.49	0.64	0.9	1
	905	14.6	2.26	0.63	0.83	1	13	2.73	0.65	0.89	1	11.4	3.29	0.66	0.96	1	10.9	3.49	0.7	0.99	1
21.7°C	605	14.4	2.25	0.4	0.54	0.67	12.9	2.72	0.39	0.54	0.7	11.4	3.29	0.38	0.55	0.72	10.9	3.49	0.38	0.58	0.77
	755	15.1	2.26	0.43	0.58	0.74	13.5	2.74	0.41	0.6	0.77	11.9	3.3	0.4	0.61	0.81	11.4	3.51	0.41	0.65	0.87
	905	15.5	2.27	0.44	0.62	0.81	13.9	2.75	0.44	0.65	0.86	12.2	3.31	0.43	0.66	0.93	11.7	3.52	0.44	0.71	0.97
Entering Wet Bulb Temperature	Total Air Volume	Outdoor Air Temperature Entering Outdoor Coil																			
		48°C					50°C					51.7°C									
		Total Cool Cap.	Comp. Motor Input	Sensible To Total Ratio (S/T)			Total Cool Cap.	Comp. Motor Input	Sensible To Total Ratio (S/T)			Total Cool Cap.	Comp. Motor Input	Sensible To Total Ratio (S/T)			Total Cool Cap.	Comp. Motor Input	Sensible To Total Ratio (S/T)		
				Dry Bulb					Dry Bulb					Dry Bulb					Dry Bulb		
L/s	kW	kW	24°C	27°C	29°C	kW	kW	24°C	27°C	29°C	kW	kW	24°C	27°C	29°C	kW	kW	24°C	27°C	29°C	
17.2°C	605	9.2	3.62	0.78	1	1	8.8	3.81	0.79	1	1	8.5	3.97	0.81	1	1					
	755	9.9	3.65	0.91	1	1	9.6	3.83	0.94	1	1	9.2	3.99	0.96	1	1					
	905	10.5	3.67	1	1	1	10.1	3.84	1	1	1	9.8	4.01	1	1	1					
19.4°C	605	9.7	3.64	0.56	0.77	1	9.3	3.82	0.56	0.77	1	8.9	3.98	0.57	0.78	1					
	755	10.1	3.65	0.62	0.88	1	9.8	3.83	0.63	0.91	1	9.4	3.99	0.63	0.93	1					
	905	10.5	3.67	0.68	1	1	10.1	3.84	0.69	1	1	9.8	4.01	0.7	1	1					
21.7°C	605	10.5	3.66	0.37	0.56	0.74	10.1	3.84	0.37	0.56	0.75	9.7	4.01	0.36	0.56	0.76					
	755	10.9	3.68	0.4	0.62	0.86	10.5	3.86	0.4	0.63	0.88	10.1	4.02	0.39	0.63	0.9					
	905	11.2	3.69	0.43	0.68	0.98	10.8	3.87	0.43	0.69	1	10.4	4.03	0.43	0.7	1					



# RATINGS

NOTE - For Temperatures and Capacities not shown in tables, see bulletin - Cooling Unit Rating Table Correction Factor Data in Miscellaneous Engineering Data section.

## 17.5 KW - KGB060S4

Entering Wet Bulb Temperature	Total Air Volume	Outdoor Air Temperature Entering Outdoor Coil																			
		26.7°C					35°C					43.3°C					46°C				
		Total Cool Cap.	Comp. Motor Input	Sensible To Total Ratio (S/T)			Total Cool Cap.	Comp. Motor Input	Sensible To Total Ratio (S/T)			Total Cool Cap.	Comp. Motor Input	Sensible To Total Ratio (S/T)			Total Cool Cap.	Comp. Motor Input	Sensible To Total Ratio (S/T)		
				Dry Bulb					Dry Bulb					Dry Bulb					Dry Bulb		
L/s	kW	kW	24°C	27°C	29°C	kW	kW	24°C	27°C	29°C	kW	kW	24°C	27°C	29°C	kW	kW	24°C	27°C	29°C	
17.2°C	755	15.8	2.67	0.73	0.91	1	14.4	3.21	0.74	0.94	1	12.9	3.89	0.76	1	1	12.4	4.14	0.81	1	1
	945	16.6	2.69	0.79	1	1	15.4	3.23	0.82	1	1	14	3.92	0.87	1	1	13.4	4.17	0.91	1	1
	1135	17.6	2.7	0.87	1	1	16.3	3.25	0.92	1	1	14.7	3.95	0.98	1	1	14.2	4.21	1	1	1
19.4°C	755	16.9	2.69	0.56	0.71	0.86	15.5	3.23	0.56	0.72	0.9	13.8	3.92	0.57	0.74	0.95	13.3	4.18	0.58	0.79	0.98
	945	17.7	2.7	0.6	0.77	0.97	16.2	3.24	0.61	0.79	1	14.4	3.94	0.63	0.84	1	13.9	4.19	0.66	0.89	1
	1135	18.3	2.71	0.64	0.85	1	16.7	3.25	0.65	0.89	1	14.9	3.95	0.68	0.95	1	14.3	4.2	0.71	0.98	1
21.7°C	755	18.1	2.71	0.42	0.55	0.68	16.6	3.25	0.41	0.55	0.7	14.8	3.95	0.4	0.56	0.72	14.2	4.2	0.41	0.58	0.76
	945	18.8	2.72	0.41	0.58	0.74	17.3	3.26	0.43	0.6	0.77	15.5	3.96	0.42	0.62	0.82	14.9	4.22	0.43	0.65	0.87
	1135	19.5	2.73	0.44	0.63	0.82	17.9	3.27	0.44	0.65	0.86	16	3.98	0.45	0.67	0.92	15.3	4.24	0.47	0.71	0.95
Entering Wet Bulb Temperature	Total Air Volume	Outdoor Air Temperature Entering Outdoor Coil																			
		48°C					50°C					51.7°C									
		Total Cool Cap.	Comp. Motor Input	Sensible To Total Ratio (S/T)			Total Cool Cap.	Comp. Motor Input	Sensible To Total Ratio (S/T)			Total Cool Cap.	Comp. Motor Input	Sensible To Total Ratio (S/T)							
				Dry Bulb					Dry Bulb					Dry Bulb							
L/s	kW	kW	24°C	27°C	29°C	kW	kW	24°C	27°C	29°C	kW	kW	24°C	27°C	29°C						
17.2°C	755	12	4.35	0.79	1	1	11.6	4.57	0.79	1	1	11.3	4.76	0.82	1	1					
	945	13	4.39	0.91	1	1	12.5	4.6	0.94	1	1	12.1	4.8	0.95	1	1					
	1135	13.7	4.41	1	1	1	13.2	4.63	1	1	1	12.8	4.83	1	1	1					
19.4°C	755	12.8	4.38	0.58	0.77	1	12.3	4.59	0.58	0.78	1	11.8	4.78	0.58	0.79	1					
	945	13.4	4.4	0.64	0.88	1	12.8	4.62	0.65	0.91	1	12.3	4.81	0.65	0.93	1					
	1135	13.7	4.41	0.69	0.99	1	13.2	4.63	0.7	1	1	12.7	4.82	0.71	1	1					
21.7°C	755	13.7	4.41	0.39	0.57	0.74	13.1	4.63	0.39	0.57	0.76	12.7	4.82	0.39	0.58	0.77					
	945	14.3	4.43	0.42	0.63	0.85	13.8	4.65	0.42	0.64	0.88	13.3	4.84	0.42	0.65	0.9					
	1135	14.7	4.45	0.45	0.69	0.97	14.2	4.67	0.45	0.7	0.99	13.6	4.86	0.46	0.71	1					

# RATINGS

NOTE – For Temperatures and Capacities not shown in tables, see bulletin – Cooling Unit Rating Table Correction Factor Data in Miscellaneous Engineering Data section.

## 21 kW - KGB072H4

Entering Wet Bulb Temperature	Total Air Volume	Outdoor Air Temperature Entering Outdoor Coil																			
		26.7°C					35°C					43.3°C					46°C				
		Total Cool Cap.	Comp. Motor Input	Sensible To Total Ratio (S/T)			Total Cool Cap.	Comp. Motor Input	Sensible To Total Ratio (S/T)			Total Cool Cap.	Comp. Motor Input	Sensible To Total Ratio (S/T)			Total Cool Cap.	Comp. Motor Input	Sensible To Total Ratio (S/T)		
				Dry Bulb					Dry Bulb					Dry Bulb					Dry Bulb		
L/s	kW	kW	24°C	27°C	29°C	kW	kW	24°C	27°C	29°C	kW	kW	24°C	27°C	29°C	kW	kW	24°C	27°C	29°C	
17.2°C	905	17.9	3.51	0.78	0.96	1.00	16.5	4.10	0.80	1.00	1.00	15.0	4.80	0.84	1.00	1.00	14.5	5.05	0.86	1.00	1.00
	1135	19.0	3.52	0.85	1.00	1.00	17.7	4.11	0.88	1.00	1.00	16.1	4.81	0.94	1.00	1.00	15.6	5.07	0.96	1.00	1.00
	1360	20.1	3.53	0.92	1.00	1.00	18.6	4.12	0.97	1.00	1.00	17.0	4.83	1.00	1.00	1.00	16.5	5.09	1.00	1.00	1.00
19.4°C	905	18.9	3.52	0.62	0.78	0.90	17.4	4.11	0.63	0.81	0.93	15.7	4.81	0.64	0.84	0.98	15.1	5.07	0.66	0.86	1.00
	1135	19.8	3.53	0.66	0.86	0.98	18.2	4.12	0.68	0.90	1.00	16.4	4.82	0.70	0.95	1.00	15.8	5.07	0.72	0.97	1.00
	1360	20.5	3.54	0.71	0.94	1.00	18.8	4.12	0.73	0.98	1.00	17.1	4.83	0.77	1.00	1.00	16.4	5.08	0.78	1.00	1.00
21.7°C	905	20.6	3.54	0.40	0.56	0.66	19.0	4.13	0.40	0.57	0.68	17.1	4.83	0.40	0.58	0.70	16.6	5.09	0.40	0.58	0.71
	1135	21.5	3.55	0.42	0.60	0.71	19.8	4.13	0.42	0.62	0.74	17.9	4.84	0.42	0.63	0.78	17.3	5.10	0.42	0.65	0.80
	1360	22.2	3.56	0.43	0.64	0.77	20.3	4.14	0.44	0.66	0.81	18.4	4.85	0.45	0.69	0.86	17.7	5.11	0.45	0.70	0.87

Entering Wet Bulb Temperature	Total Air Volume	Outdoor Air Temperature Entering Outdoor Coil														
		48°C					50°C					51.7°C				
		Total Cool Cap.	Comp. Motor Input	Sensible To Total Ratio (S/T)			Total Cool Cap.	Comp. Motor Input	Sensible To Total Ratio (S/T)			Total Cool Cap.	Comp. Motor Input	Sensible To Total Ratio (S/T)		
				Dry Bulb					Dry Bulb					Dry Bulb		
L/s	kW	kW	24°C	27°C	29°C	kW	kW	24°C	27°C	29°C	kW	kW	24°C	27°C	29°C	
17.2°C	905	14.2	5.26	0.87	1.00	1.00	13.8	5.48	0.88	1.00	1.00	13.4	5.67	0.90	1.00	1.00
	1135	15.2	5.27	0.97	1.00	1.00	14.8	5.50	0.99	1.00	1.00	14.4	5.69	1.00	1.00	1.00
	1360	16.1	5.29	1.00	1.00	1.00	15.6	5.51	1.00	1.00	1.00	15.1	5.70	1.00	1.00	1.00
19.4°C	905	14.7	5.26	0.66	0.88	1.00	14.2	5.49	0.67	0.89	1.00	13.7	5.67	0.67	0.91	1.00
	1135	15.3	5.28	0.73	0.99	1.00	14.8	5.49	0.74	1.00	1.00	14.4	5.69	0.75	1.00	1.00
	1360	16.0	5.29	0.79	1.00	1.00	15.5	5.51	0.81	1.00	1.00	15.1	5.71	0.81	1.00	1.00
21.7°C	905	16.1	5.29	0.40	0.59	0.72	15.5	5.51	0.41	0.60	0.74	15.1	5.70	0.41	0.61	0.75
	1135	16.7	5.31	0.42	0.66	0.81	16.2	5.53	0.43	0.67	0.82	15.7	5.72	0.43	0.67	0.84
	1360	17.2	5.32	0.45	0.71	0.89	16.7	5.54	0.45	0.73	0.91	16.1	5.73	0.46	0.73	0.93

# RATINGS

NOTE – For Temperatures and Capacities not shown in tables, see bulletin – Cooling Unit Rating Table Correction Factor Data in Miscellaneous Engineering Data section.

## 21 kW - KGB074S4T - COOLING CAPACITY (1ST STAGE)

Entering Wet Bulb Temperature	Total Air Volume	Outdoor Air Temperature Entering Outdoor Coil																			
		18.1°C					24°C					29°C					35°C				
		Total Cool Cap.	Comp. Motor Input	Sensible To Total Ratio (S/T)			Total Cool Cap.	Comp. Motor Input	Sensible To Total Ratio (S/T)			Total Cool Cap.	Comp. Motor Input	Sensible To Total Ratio (S/T)			Total Cool Cap.	Comp. Motor Input	Sensible To Total Ratio (S/T)		
				Dry Bulb					Dry Bulb					Dry Bulb					Dry Bulb		
L/s	kW	kW	24°C	27°C	29°C	kW	kW	24°C	27°C	29°C	kW	kW	24°C	27°C	29°C	kW	kW	24°C	27°C	29°C	
17.2°C	565	13.7	1.88	0.74	0.88	0.97	13.1	2.16	0.75	0.90	0.99	12.5	2.44	0.76	0.92	1.00	11.7	2.81	0.78	0.95	1.00
	755	14.8	1.87	0.81	0.98	1.00	14.1	2.15	0.82	1.00	1.00	13.5	2.43	0.84	1.00	1.00	12.8	2.80	0.86	1.00	1.00
	945	16.0	1.85	0.88	1.00	1.00	15.3	2.14	0.90	1.00	1.00	14.6	2.41	0.92	1.00	1.00	13.7	2.79	0.95	1.00	1.00
19.4°C	565	14.7	1.87	0.59	0.74	0.82	14.0	2.15	0.60	0.75	0.84	13.3	2.43	0.61	0.76	0.86	12.5	2.80	0.62	0.78	0.88
	755	15.8	1.85	0.65	0.82	0.92	15.0	2.14	0.66	0.82	0.94	14.3	2.42	0.64	0.84	0.96	13.3	2.79	0.67	0.87	0.99
	945	16.5	1.84	0.69	0.88	1.00	15.7	2.13	0.71	0.91	1.00	15.0	2.41	0.71	0.93	1.00	14.0	2.79	0.73	0.96	1.00
21.7°C	565	16.1	1.85	0.41	0.54	0.62	15.3	2.14	0.41	0.54	0.63	14.6	2.41	0.41	0.55	0.64	13.7	2.79	0.41	0.56	0.65
	755	17.2	1.83	0.44	0.59	0.69	16.4	2.12	0.43	0.60	0.70	15.6	2.40	0.42	0.60	0.71	14.7	2.78	0.43	0.61	0.73
	945	18.1	1.82	0.45	0.63	0.74	17.2	2.11	0.45	0.64	0.75	16.4	2.39	0.45	0.64	0.78	15.4	2.77	0.46	0.67	0.80

## 21 kW - KGB074S4T - COOLING CAPACITY (2ND STAGE)

Entering Wet Bulb Temperature	Total Air Volume	Outdoor Air Temperature Entering Outdoor Coil																			
		26.7°C					35°C					43.3°C					46°C				
		Total Cool Cap.	Comp. Motor Input	Sensible To Total Ratio (S/T)			Total Cool Cap.	Comp. Motor Input	Sensible To Total Ratio (S/T)			Total Cool Cap.	Comp. Motor Input	Sensible To Total Ratio (S/T)			Total Cool Cap.	Comp. Motor Input	Sensible To Total Ratio (S/T)		
				Dry Bulb					Dry Bulb					Dry Bulb					Dry Bulb		
L/s	kW	kW	24°C	27°C	29°C	kW	kW	24°C	27°C	29°C	kW	kW	24°C	27°C	29°C	kW	kW	24°C	27°C	29°C	
17.2°C	905	18.0	3.26	0.80	0.97	1.00	16.5	3.90	0.82	1.00	1.00	15.1	4.69	0.86	1.00	1.00	14.7	4.98	0.87	1.00	1.00
	1135	19.1	3.29	0.87	1.00	1.00	17.8	3.95	0.90	1.00	1.00	16.2	4.73	0.95	1.00	1.00	15.7	5.01	0.97	1.00	1.00
	1360	20.2	3.33	0.94	1.00	1.00	18.6	3.98	0.98	1.00	1.00	17.1	4.76	1.00	1.00	1.00	16.6	5.05	1.00	1.00	1.00
19.4°C	905	19.0	3.29	0.64	0.81	0.91	17.5	3.93	0.65	0.83	0.95	15.8	4.71	0.67	0.86	0.99	15.2	5.00	0.68	0.88	1.00
	1135	19.9	3.32	0.69	0.88	0.99	18.2	3.96	0.70	0.91	1.00	16.5	4.74	0.73	0.97	1.00	15.9	5.02	0.75	0.98	1.00
	1360	20.5	3.34	0.73	0.95	1.00	18.8	3.98	0.76	0.99	1.00	17.0	4.76	0.79	1.00	1.00	16.5	5.04	0.81	1.00	1.00
21.7°C	905	20.6	3.34	0.44	0.59	0.68	18.9	3.99	0.43	0.59	0.70	17.1	4.76	0.42	0.61	0.72	16.6	5.04	0.43	0.62	0.74
	1135	21.5	3.37	0.44	0.62	0.74	19.7	4.02	0.45	0.64	0.77	17.8	4.79	0.45	0.66	0.80	17.2	5.07	0.44	0.68	0.82
	1360	22.1	3.39	0.46	0.66	0.80	20.3	4.04	0.47	0.69	0.84	18.3	4.81	0.47	0.72	0.88	17.7	5.09	0.47	0.73	0.90

Entering Wet Bulb Temperature	Total Air Volume	Outdoor Air Temperature Entering Outdoor Coil																			
		48°C					50°C					51.7°C									
		Total Cool Cap.	Comp. Motor Input	Sensible To Total Ratio (S/T)			Total Cool Cap.	Comp. Motor Input	Sensible To Total Ratio (S/T)			Total Cool Cap.	Comp. Motor Input	Sensible To Total Ratio (S/T)							
				Dry Bulb					Dry Bulb					Dry Bulb							
L/s	kW	kW	24°C	27°C	29°C	kW	kW	24°C	27°C	29°C	kW	kW	24°C	27°C	29°C	kW	kW	24°C	27°C	29°C	
17.2°C	905	14.3	5.21	0.88	1.00	1.00	14.0	5.44	0.89	1.00	1.00	13.6	5.64	0.91	1.00	1.00					
	1135	15.3	5.23	0.98	1.00	1.00	14.9	5.47	0.99	1.00	1.00	14.5	5.67	1.00	1.00	1.00					
	1360	16.1	5.27	1.00	1.00	1.00	15.7	5.50	1.00	1.00	1.00	15.2	5.70	1.00	1.00	1.00					
19.4°C	905	14.8	5.22	0.68	0.90	1.00	14.3	5.45	0.69	0.91	1.00	13.9	5.65	0.69	0.92	1.00					
	1135	15.4	5.24	0.75	0.99	1.00	14.9	5.47	0.76	1.00	1.00	14.6	5.68	0.77	1.00	1.00					
	1360	16.0	5.26	0.82	1.00	1.00	15.6	5.49	0.82	1.00	1.00	15.3	5.70	0.83	1.00	1.00					
21.7°C	905	16.1	5.26	0.43	0.63	0.75	15.6	5.50	0.43	0.63	0.76	15.2	5.69	0.42	0.63	0.76					
	1135	16.7	5.29	0.45	0.68	0.83	16.2	5.52	0.45	0.69	0.84	15.8	5.72	0.46	0.70	0.86					
	1360	17.2	5.31	0.48	0.74	0.91	16.7	5.54	0.48	0.75	0.93	16.1	5.73	0.48	0.76	0.94					

# RATINGS

NOTE – For Temperatures and Capacities not shown in tables, see bulletin – Cooling Unit Rating Table Correction Factor Data in Miscellaneous Engineering Data section.

## 21 kW - KGB074S4B - COOLING CAPACITY (1ST STAGE)

Entering Wet Bulb Temperature	Total Air Volume	Outdoor Air Temperature Entering Outdoor Coil																							
		18.1°C						24°C						29°C						35°C					
		Total Cool Cap.	Comp. Motor Input	Sensible To Total Ratio (S/T)			Total Cool Cap.	Comp. Motor Input	Sensible To Total Ratio (S/T)			Total Cool Cap.	Comp. Motor Input	Sensible To Total Ratio (S/T)			Total Cool Cap.	Comp. Motor Input	Sensible To Total Ratio (S/T)						
				Dry Bulb					Dry Bulb					Dry Bulb					Dry Bulb						
L/s	kW	kW	24°C	27°C	29°C	kW	kW	24°C	27°C	29°C	kW	kW	24°C	27°C	29°C	kW	kW	24°C	27°C	29°C					
17.2°C	565	16.0	16.5	.86	1.00	1.00	15.3	19.9	.88	1.00	1.00	14.6	23.0	.90	1.00	1.00	13.7	27.1	.94	1.00	1.00				
	755	17.1	16.3	.95	1.00	1.00	16.4	19.8	.97	1.00	1.00	15.6	22.9	.99	1.00	1.00	14.7	27.0	1.00	1.00	1.00				
	945	18.1	16.1	1.00	1.00	1.00	17.2	19.6	1.00	1.00	1.00	16.4	22.8	1.00	1.00	1.00	15.4	27.0	1.00	1.00	1.00				
19.4°C	565	16.7	16.3	.68	.87	.98	15.8	19.8	.69	.88	1.00	15.0	23.0	.70	.91	1.00	14.0	27.1	.72	.95	1.00				
	755	17.4	16.2	.74	.96	1.00	16.5	19.7	.76	.98	1.00	15.7	22.9	.77	1.00	1.00	14.7	27.0	.80	1.00	1.00				
	945	18.0	16.1	.79	1.00	1.00	17.2	19.6	.81	1.00	1.00	16.4	22.8	.83	1.00	1.00	15.4	27.0	.87	1.00	1.00				
21.7°C	565	18.2	16.1	.45	.62	.74	17.2	19.6	.45	.62	.74	16.4	22.8	.45	.64	.76	15.3	27.0	.44	.65	.78				
	755	18.9	16.0	.46	.68	.80	17.9	19.5	.48	.69	.83	17.1	22.8	.48	.70	.85	15.9	26.9	.48	.72	.88				
	945	19.4	15.9	.48	.72	.88	18.5	19.5	.50	.74	.90	17.5	22.7	.50	.75	.91	16.3	26.9	.51	.78	.95				

## 21 kW - KGB074S4B - COOLING CAPACITY (2ND STAGE)

Entering Wet Bulb Temperature	Total Air Volume	Outdoor Air Temperature Entering Outdoor Coil																							
		26.7°C						35°C						43.3°C						46°C					
		Total Cool Cap.	Comp. Motor Input	Sensible To Total Ratio (S/T)			Total Cool Cap.	Comp. Motor Input	Sensible To Total Ratio (S/T)			Total Cool Cap.	Comp. Motor Input	Sensible To Total Ratio (S/T)			Total Cool Cap.	Comp. Motor Input	Sensible To Total Ratio (S/T)						
				Dry Bulb					Dry Bulb					Dry Bulb					Dry Bulb						
L/s	kW	kW	24°C	27°C	29°C	kW	kW	24°C	27°C	29°C	kW	kW	24°C	27°C	29°C	kW	kW	24°C	27°C	29°C					
17.2°C	905	18.0	31.7	.80	.97	1.00	16.5	37.9	.82	1.00	1.00	15.1	45.6	.86	1.00	1.00	14.7	48.4	.87	1.00	1.00				
	1135	19.1	32.0	.87	1.00	1.00	17.8	38.4	.90	1.00	1.00	16.2	45.9	.95	1.00	1.00	15.7	48.7	.97	1.00	1.00				
	1360	20.2	32.3	.94	1.00	1.00	18.7	38.6	.98	1.00	1.00	17.1	46.3	1.00	1.00	1.00	16.6	49.0	1.00	1.00	1.00				
19.4°C	905	19.0	32.0	.64	.81	.91	17.5	38.2	.65	.83	.95	15.8	45.8	.67	.86	.99	15.2	48.5	.68	.88	1.00				
	1135	19.9	32.2	.69	.88	.99	18.2	38.5	.70	.91	1.00	16.5	46.1	.73	.97	1.00	15.9	48.8	.75	.98	1.00				
	1360	20.5	32.4	.73	.95	1.00	18.8	38.7	.76	.99	1.00	17.1	46.2	.79	1.00	1.00	16.5	49.0	.81	1.00	1.00				
21.7°C	905	20.6	32.5	.43	.59	.68	19.0	38.7	.43	.59	.70	17.2	46.3	.42	.61	.72	16.6	49.0	.43	.62	.74				
	1135	21.5	32.7	.44	.62	.74	19.7	39.0	.45	.64	.77	17.8	46.5	.45	.66	.80	17.2	49.3	.44	.68	.82				
	1360	22.1	33.0	.46	.66	.80	20.3	39.3	.46	.69	.84	18.3	46.8	.47	.72	.88	17.7	49.5	.47	.73	.90				

Entering Wet Bulb Temperature	Total Air Volume	Outdoor Air Temperature Entering Outdoor Coil																	
		48°C						50°C						51.7°C					
		Total Cool Cap.	Comp. Motor Input	Sensible To Total Ratio (S/T)			Total Cool Cap.	Comp. Motor Input	Sensible To Total Ratio (S/T)			Total Cool Cap.	Comp. Motor Input	Sensible To Total Ratio (S/T)					
				Dry Bulb					Dry Bulb					Dry Bulb					
L/s	kW	kW	24°C	27°C	29°C	kW	kW	24°C	27°C	29°C	kW	kW	24°C	27°C	29°C				
17.2°C	905	14.3	50.6	.88	1.00	1.00	14.0	52.9	.89	1.00	1.00	13.6	54.8	.91	1.00	1.00			
	1135	15.3	50.9	.98	1.00	1.00	14.9	53.2	.99	1.00	1.00	14.5	55.1	1.00	1.00	1.00			
	1360	16.1	51.2	1.00	1.00	1.00	15.7	53.5	1.00	1.00	1.00	15.2	55.4	1.00	1.00	1.00			
19.4°C	905	14.8	50.7	.68	.90	1.00	14.3	52.9	.69	.91	1.00	13.9	54.9	.69	.92	1.00			
	1135	15.4	50.9	.75	.99	1.00	14.9	53.2	.76	1.00	1.00	14.6	55.2	.77	1.00	1.00			
	1360	16.0	51.1	.82	1.00	1.00	15.6	53.4	.82	1.00	1.00	15.3	55.4	.82	1.00	1.00			
21.7°C	905	16.1	51.2	.43	.63	.75	15.6	53.4	.43	.63	.76	15.2	55.3	.42	.63	.76			
	1135	16.7	51.4	.45	.68	.83	16.2	53.7	.45	.69	.84	15.8	55.6	.46	.70	.86			
	1360	17.2	51.6	.48	.74	.91	16.7	53.8	.48	.75	.93	16.2	55.8	.48	.76	.94			

# RATINGS

NOTE – For Temperatures and Capacities not shown in tables, see bulletin – Cooling Unit Rating Table Correction Factor Data in Miscellaneous Engineering Data section.

## 21 kW - KGB074H4T - COOLING CAPACITY (1ST STAGE)

Entering Wet Bulb Temperature	Total Air Volume	Outdoor Air Temperature Entering Outdoor Coil																			
		18.1°C					24°C					29°C					35°C				
		Total Cool Cap.	Comp. Motor Input	Sensible To Total Ratio (S/T)			Total Cool Cap.	Comp. Motor Input	Sensible To Total Ratio (S/T)			Total Cool Cap.	Comp. Motor Input	Sensible To Total Ratio (S/T)			Total Cool Cap.	Comp. Motor Input	Sensible To Total Ratio (S/T)		
				Dry Bulb					Dry Bulb					Dry Bulb					Dry Bulb		
L/s	kW	kW	24°C	27°C	29°C	kW	kW	24°C	27°C	29°C	kW	kW	24°C	27°C	29°C	kW	kW	24°C	27°C	29°C	
17.2°C	565	13.7	1.85	0.74	0.88	0.97	13.1	2.13	0.75	0.90	0.99	12.5	2.40	0.76	0.92	1.00	11.7	2.77	0.78	0.95	1.00
	755	14.8	1.84	0.81	0.98	1.00	14.1	2.12	0.82	1.00	1.00	13.5	2.39	0.84	1.00	1.00	12.8	2.76	0.86	1.00	1.00
	945	16.0	1.83	0.88	1.00	1.00	15.3	2.11	0.90	1.00	1.00	14.6	2.38	0.92	1.00	1.00	13.7	2.75	0.95	1.00	1.00
19.4°C	565	14.7	1.84	0.59	0.74	0.82	14.0	2.13	0.60	0.75	0.84	13.3	2.40	0.61	0.76	0.86	12.5	2.77	0.62	0.78	0.88
	755	15.8	1.83	0.65	0.82	0.92	15.0	2.11	0.66	0.82	0.94	14.3	2.39	0.64	0.84	0.96	13.3	2.76	0.67	0.87	0.99
	945	16.5	1.82	0.69	0.88	1.00	15.7	2.10	0.71	0.91	1.00	15.0	2.38	0.71	0.93	1.00	14.0	2.75	0.73	0.96	1.00
21.7°C	565	16.1	1.83	0.41	0.54	0.62	15.3	2.11	0.42	0.54	0.63	14.6	2.38	0.41	0.55	0.64	13.7	2.75	0.41	0.56	0.65
	755	17.2	1.81	0.43	0.59	0.69	16.4	2.09	0.43	0.60	0.70	15.6	2.37	0.42	0.60	0.71	14.7	2.74	0.43	0.61	0.73
	945	18.1	1.80	0.45	0.63	0.74	17.2	2.08	0.45	0.64	0.75	16.4	2.36	0.45	0.64	0.78	15.4	2.73	0.46	0.67	0.80

## 21 kW - KGB074H4T - COOLING CAPACITY (2ND STAGE)

Entering Wet Bulb Temperature	Total Air Volume	Outdoor Air Temperature Entering Outdoor Coil																			
		26.7°C					35°C					43.3°C					46°C				
		Total Cool Cap.	Comp. Motor Input	Sensible To Total Ratio (S/T)			Total Cool Cap.	Comp. Motor Input	Sensible To Total Ratio (S/T)			Total Cool Cap.	Comp. Motor Input	Sensible To Total Ratio (S/T)			Total Cool Cap.	Comp. Motor Input	Sensible To Total Ratio (S/T)		
				Dry Bulb					Dry Bulb					Dry Bulb					Dry Bulb		
L/s	kW	kW	24°C	27°C	29°C	kW	kW	24°C	27°C	29°C	kW	kW	24°C	27°C	29°C	kW	kW	24°C	27°C	29°C	
17.2°C	905	18.0	3.22	0.80	0.97	1.00	16.5	3.85	0.82	1.00	1.00	15.1	4.63	0.86	1.00	1.00	14.7	4.91	0.87	1.00	1.00
	1135	19.1	3.25	0.87	1.00	1.00	17.8	3.90	0.90	1.00	1.00	16.2	4.66	0.95	1.00	1.00	15.7	4.94	0.97	1.00	1.00
	1360	20.2	3.28	0.94	1.00	1.00	18.6	3.92	0.98	1.00	1.00	17.1	4.70	1.00	1.00	1.00	16.6	4.98	1.00	1.00	1.00
19.4°C	905	19.0	3.25	0.64	0.81	0.91	17.5	3.88	0.65	0.83	0.95	15.8	4.65	0.67	0.86	0.99	15.2	4.93	0.68	0.88	1.00
	1135	19.9	3.27	0.69	0.88	0.99	18.2	3.91	0.70	0.91	1.00	16.5	4.68	0.73	0.97	1.00	15.9	4.95	0.75	0.98	1.00
	1360	20.5	3.29	0.73	0.95	1.00	18.8	3.93	0.76	0.99	1.00	17.1	4.69	0.79	1.00	1.00	16.5	4.97	0.81	1.00	1.00
21.7°C	905	20.6	3.30	0.43	0.59	0.68	18.9	3.93	0.43	0.60	0.70	17.1	4.70	0.42	0.61	0.72	16.6	4.98	0.43	0.62	0.74
	1135	21.5	3.32	0.44	0.62	0.74	19.7	3.96	0.45	0.64	0.77	17.8	4.72	0.45	0.66	0.80	17.2	5.00	0.44	0.68	0.82
	1360	22.1	3.35	0.46	0.66	0.80	20.3	3.99	0.47	0.69	0.84	18.3	4.75	0.47	0.72	0.88	17.7	5.02	0.47	0.73	0.90

Entering Wet Bulb Temperature	Total Air Volume	Outdoor Air Temperature Entering Outdoor Coil														
		48°C					50°C					51.7°C				
		Total Cool Cap.	Comp. Motor Input	Sensible To Total Ratio (S/T)			Total Cool Cap.	Comp. Motor Input	Sensible To Total Ratio (S/T)			Total Cool Cap.	Comp. Motor Input	Sensible To Total Ratio (S/T)		
				Dry Bulb					Dry Bulb					Dry Bulb		
L/s	kW	kW	24°C	27°C	29°C	kW	kW	24°C	27°C	29°C	kW	kW	24°C	27°C	29°C	
17.2°C	905	14.3	5.14	0.88	1.00	1.00	14.0	5.37	0.89	1.00	1.00	13.6	5.57	0.91	1.00	1.00
	1135	15.3	5.16	0.98	1.00	1.00	14.9	5.40	0.99	1.00	1.00	14.5	5.60	1.00	1.00	1.00
	1360	16.1	5.20	1.00	1.00	1.00	15.7	5.43	1.00	1.00	1.00	15.2	5.62	1.00	1.00	1.00
19.4°C	905	14.8	5.15	0.68	0.90	1.00	14.3	5.37	0.69	0.91	1.00	13.9	5.57	0.69	0.92	1.00
	1135	15.4	5.17	0.75	0.99	1.00	14.9	5.40	0.76	1.00	1.00	14.6	5.60	0.77	1.00	1.00
	1360	16.0	5.19	0.82	1.00	1.00	15.6	5.42	0.82	1.00	1.00	15.3	5.63	0.83	1.00	1.00
21.7°C	905	16.1	5.19	0.43	0.63	0.75	15.6	5.42	0.43	0.63	0.76	15.2	5.62	0.42	0.63	0.76
	1135	16.7	5.22	0.45	0.68	0.83	16.2	5.45	0.45	0.69	0.84	15.8	5.65	0.46	0.70	0.86
	1360	17.2	5.24	0.48	0.74	0.91	16.7	5.47	0.48	0.75	0.93	16.1	5.66	0.48	0.76	0.94

# RATINGS

NOTE – For Temperatures and Capacities not shown in tables, see bulletin – Cooling Unit Rating Table Correction Factor Data in Miscellaneous Engineering Data section.

## 21 kW - KGB090S4B - COOLING CAPACITY (1ST STAGE)

Entering Wet Bulb Temperature	Total Air Volume	Outdoor Air Temperature Entering Outdoor Coil																			
		18.1°C					24°C					29°C					35°C				
		Total Cool Cap.	Comp. Motor Input	Sensible To Total Ratio (S/T)			Total Cool Cap.	Comp. Motor Input	Sensible To Total Ratio (S/T)			Total Cool Cap.	Comp. Motor Input	Sensible To Total Ratio (S/T)			Total Cool Cap.	Comp. Motor Input	Sensible To Total Ratio (S/T)		
				Dry Bulb					Dry Bulb					Dry Bulb					Dry Bulb		
L/s	kW	kW	24°C	27°C	29°C	kW	kW	24°C	27°C	29°C	kW	kW	24°C	27°C	29°C	kW	kW	24°C	27°C	29°C	
17.2°C	1135	19.8	2.18	0.87	1.00	1.00	18.7	2.59	0.89	1.00	1.00	17.6	2.97	0.91	1.00	1.00	16.2	3.47	0.94	1.00	1.00
	1415	21.4	2.18	0.96	1.00	1.00	20.0	2.59	0.98	1.00	1.00	18.9	2.97	1.00	1.00	1.00	17.5	3.47	1.00	1.00	1.00
	1700	22.5	2.18	1.00	1.00	1.00	21.1	2.59	1.00	1.00	1.00	19.9	2.97	1.00	1.00	1.00	18.4	3.47	1.00	1.00	1.00
19.4°C	1135	20.7	2.18	0.68	0.88	0.99	19.3	2.59	0.68	0.90	1.00	18.1	2.97	0.69	0.92	1.00	16.5	3.47	0.70	0.96	1.00
	1415	21.7	2.18	0.73	0.97	1.00	20.1	2.59	0.75	0.99	1.00	18.9	2.97	0.76	1.00	1.00	17.5	3.47	0.79	1.00	1.00
	1700	22.5	2.18	0.79	1.00	1.00	21.1	2.59	0.82	1.00	1.00	20.0	2.97	0.83	1.00	1.00	18.4	3.47	0.86	1.00	1.00
21.7°C	1135	22.8	2.18	0.42	0.61	0.73	21.2	2.59	0.44	0.62	0.75	19.9	2.97	0.42	0.62	0.76	18.3	3.47	0.41	0.63	0.78
	1415	23.7	2.18	0.45	0.67	0.80	22.1	2.59	0.44	0.68	0.83	20.7	2.97	0.45	0.69	0.85	19.0	3.47	0.45	0.71	0.88
	1700	24.5	2.19	0.48	0.72	0.88	22.7	2.59	0.48	0.74	0.91	21.3	2.97	0.48	0.75	0.94	19.5	3.47	0.47	0.77	0.97

## 21 kW - KGB090S4B - COOLING CAPACITY (2ND STAGE)

Entering Wet Bulb Temperature	Total Air Volume	Outdoor Air Temperature Entering Outdoor Coil																			
		26.7°C					35°C					43.3°C					46°C				
		Total Cool Cap.	Comp. Motor Input	Sensible To Total Ratio (S/T)			Total Cool Cap.	Comp. Motor Input	Sensible To Total Ratio (S/T)			Total Cool Cap.	Comp. Motor Input	Sensible To Total Ratio (S/T)			Total Cool Cap.	Comp. Motor Input	Sensible To Total Ratio (S/T)		
				Dry Bulb					Dry Bulb					Dry Bulb					Dry Bulb		
L/s	kW	kW	24°C	27°C	29°C	kW	kW	24°C	27°C	29°C	kW	kW	24°C	27°C	29°C	kW	kW	24°C	27°C	29°C	
17.2°C	1135	24.1	4.91	0.77	0.94	1.00	21.9	5.67	0.79	0.98	1.00	19.4	6.56	0.82	1.00	1.00	18.7	6.87	0.83	1.00	1.00
	1415	25.6	5.01	0.84	1.00	1.00	23.4	5.79	0.87	1.00	1.00	21.1	6.70	0.91	1.00	1.00	20.3	7.02	0.93	1.00	1.00
	1700	27.1	5.11	0.90	1.00	1.00	24.8	5.91	0.94	1.00	1.00	22.3	6.80	0.99	1.00	1.00	21.5	7.12	1.00	1.00	1.00
19.4°C	1135	25.7	5.01	0.62	0.78	0.88	23.2	5.78	0.63	0.80	0.91	20.7	6.66	0.64	0.83	0.96	19.7	6.97	0.64	0.85	0.98
	1415	27.0	5.10	0.66	0.85	0.97	24.4	5.87	0.68	0.88	1.00	21.7	6.75	0.69	0.92	1.00	20.7	7.05	0.70	0.94	1.00
	1700	27.9	5.17	0.71	0.92	1.00	25.3	5.93	0.72	0.95	1.00	22.4	6.82	0.75	1.00	1.00	21.5	7.13	0.76	1.00	1.00
21.7°C	1135	28.1	5.18	0.41	0.56	0.65	25.5	5.95	0.40	0.57	0.67	22.8	6.84	0.39	0.58	0.69	21.8	7.15	0.39	0.58	0.70
	1415	29.4	5.27	0.43	0.61	0.72	26.7	6.04	0.43	0.62	0.74	23.7	6.93	0.41	0.63	0.76	22.8	7.24	0.41	0.63	0.78
	1700	30.3	5.33	0.45	0.64	0.77	27.5	6.11	0.44	0.65	0.80	24.5	7.00	0.43	0.68	0.84	23.5	7.31	0.43	0.69	0.85

Entering Wet Bulb Temperature	Total Air Volume	Outdoor Air Temperature Entering Outdoor Coil																	
		48°C					50°C					51.7°C							
		Total Cool Cap.	Comp. Motor Input	Sensible To Total Ratio (S/T)			Total Cool Cap.	Comp. Motor Input	Sensible To Total Ratio (S/T)			Total Cool Cap.	Comp. Motor Input	Sensible To Total Ratio (S/T)					
				Dry Bulb					Dry Bulb					Dry Bulb					
L/s	kW	kW	24°C	27°C	29°C	kW	kW	24°C	27°C	29°C	kW	kW	24°C	27°C	29°C				
17.2°C	1135	18.1	7.12	0.84	1.00	1.00	17.5	7.38	0.86	1.00	1.00	17.0	7.61	0.87	1.00	1.00			
	1415	19.7	7.26	0.94	1.00	1.00	19.0	7.53	0.96	1.00	1.00	18.4	7.75	0.98	1.00	1.00			
	1700	20.7	7.37	1.00	1.00	1.00	20.1	7.64	1.00	1.00	1.00	19.5	7.87	1.00	1.00	1.00			
19.4°C	1135	19.0	7.21	0.64	0.86	0.99	18.3	7.46	0.64	0.87	1.00	17.7	7.69	0.65	0.88	1.00			
	1415	20.0	7.29	0.70	0.95	1.00	19.2	7.55	0.71	0.97	1.00	18.5	7.77	0.72	0.99	1.00			
	1700	20.8	7.38	0.77	1.00	1.00	20.2	7.64	0.79	1.00	1.00	19.5	7.86	0.79	1.00	1.00			
21.7°C	1135	21.1	7.39	0.38	0.58	0.71	20.3	7.65	0.38	0.58	0.72	19.5	7.88	0.37	0.59	0.72			
	1415	22.0	7.49	0.41	0.64	0.79	21.2	7.74	0.41	0.64	0.80	20.5	7.96	0.40	0.65	0.81			
	1700	22.7	7.55	0.43	0.69	0.87	21.8	7.81	0.43	0.70	0.88	21.1	8.04	0.44	0.72	0.90			



# RATINGS

NOTE – For Temperatures and Capacities not shown in tables, see bulletin – Cooling Unit Rating Table Correction Factor Data in Miscellaneous Engineering Data section.

## 21 kW - KGB090S4T - COOLING CAPACITY (1ST STAGE)

Entering Wet Bulb Temperature	Total Air Volume	Outdoor Air Temperature Entering Outdoor Coil																							
		18.1°C						24°C						29°C						35°C					
		Total Cool Cap.	Comp. Motor Input	Sensible To Total Ratio (S/T)			Total Cool Cap.	Comp. Motor Input	Sensible To Total Ratio (S/T)			Total Cool Cap.	Comp. Motor Input	Sensible To Total Ratio (S/T)			Total Cool Cap.	Comp. Motor Input	Sensible To Total Ratio (S/T)						
				Dry Bulb					Dry Bulb					Dry Bulb					Dry Bulb						
L/s	kW	kW	24°C	27°C	29°C	kW	kW	24°C	27°C	29°C	kW	kW	24°C	27°C	29°C	kW	kW	24°C	27°C	29°C					
17.2°C	755	17.5	2.22	0.76	0.92	1.00	16.2	2.63	0.77	0.94	1.00	15.1	3.02	0.78	0.97	1.00	13.7	3.52	0.79	0.99	1.00				
	945	18.6	2.22	0.82	1.00	1.00	17.4	2.63	0.84	1.00	1.00	16.3	3.01	0.85	1.00	1.00	15.1	3.52	0.88	1.00	1.00				
	1135	19.8	2.22	0.88	1.00	1.00	18.6	2.63	0.91	1.00	1.00	17.5	3.02	0.93	1.00	1.00	16.1	3.52	0.97	1.00	1.00				
19.4°C	755	18.7	2.22	0.62	0.76	0.86	17.4	2.63	0.61	0.78	0.88	16.2	3.02	0.62	0.79	0.90	14.8	3.52	0.62	0.81	0.93				
	945	19.8	2.22	0.66	0.83	0.94	18.4	2.63	0.66	0.84	0.96	17.1	3.02	0.67	0.86	0.99	15.6	3.52	0.67	0.89	1.00				
	1135	20.6	2.22	0.69	0.89	1.00	19.1	2.63	0.70	0.91	1.00	17.8	3.01	0.71	0.94	1.00	16.2	3.52	0.73	0.98	1.00				
21.7°C	755	20.7	2.22	0.42	0.56	0.64	19.3	2.63	0.41	0.56	0.65	18.0	3.02	0.40	0.56	0.66	16.4	3.52	0.38	0.56	0.67				
	945	21.8	2.22	0.45	0.60	0.70	20.3	2.63	0.43	0.59	0.71	18.9	3.02	0.41	0.60	0.72	17.3	3.52	0.41	0.61	0.74				
	1135	22.6	2.22	0.45	0.61	0.75	21.0	2.63	0.44	0.64	0.76	19.7	3.02	0.42	0.65	0.79	18.0	3.53	0.43	0.66	0.80				

## 21 kW - KGB090S4T - COOLING CAPACITY (2ND STAGE)

Entering Wet Bulb Temperature	Total Air Volume	Outdoor Air Temperature Entering Outdoor Coil																							
		26.7°C						35°C						43.3°C						46°C					
		Total Cool Cap.	Comp. Motor Input	Sensible To Total Ratio (S/T)			Total Cool Cap.	Comp. Motor Input	Sensible To Total Ratio (S/T)			Total Cool Cap.	Comp. Motor Input	Sensible To Total Ratio (S/T)			Total Cool Cap.	Comp. Motor Input	Sensible To Total Ratio (S/T)						
				Dry Bulb					Dry Bulb					Dry Bulb					Dry Bulb						
L/s	kW	kW	24°C	27°C	29°C	kW	kW	24°C	27°C	29°C	kW	kW	24°C	27°C	29°C	kW	kW	24°C	27°C	29°C					
17.2°C	1135	24.1	4.91	0.77	0.94	1.00	21.9	5.67	0.79	0.98	1.00	19.4	6.56	0.82	1.00	1.00	18.7	6.87	0.83	1.00	1.00				
	1415	25.6	5.01	0.84	1.00	1.00	23.4	5.79	0.87	1.00	1.00	21.1	6.70	0.91	1.00	1.00	20.3	7.02	0.93	1.00	1.00				
	1700	27.1	5.11	0.90	1.00	1.00	24.8	5.91	0.94	1.00	1.00	22.3	6.80	0.99	1.00	1.00	21.5	7.12	1.00	1.00	1.00				
19.4°C	1135	25.7	5.01	0.62	0.78	0.88	23.2	5.78	0.63	0.80	0.91	20.7	6.66	0.64	0.83	0.96	19.7	6.97	0.64	0.85	0.98				
	1415	27.0	5.10	0.66	0.85	0.97	24.4	5.87	0.68	0.88	1.00	21.7	6.75	0.69	0.92	1.00	20.7	7.05	0.70	0.94	1.00				
	1700	27.9	5.17	0.71	0.92	1.00	25.3	5.93	0.72	0.95	1.00	22.4	6.82	0.75	1.00	1.00	21.5	7.13	0.76	1.00	1.00				
21.7°C	1135	28.1	5.18	0.41	0.56	0.65	25.5	5.95	0.40	0.57	0.67	22.8	6.84	0.39	0.58	0.69	21.8	7.15	0.39	0.58	0.70				
	1415	29.4	5.27	0.43	0.61	0.72	26.7	6.04	0.43	0.62	0.74	23.7	6.93	0.41	0.63	0.76	22.8	7.24	0.41	0.63	0.78				
	1700	30.3	5.33	0.45	0.64	0.77	27.5	6.11	0.44	0.65	0.80	24.5	7.00	0.43	0.68	0.84	23.5	7.31	0.43	0.69	0.85				

Entering Wet Bulb Temperature	Total Air Volume	Outdoor Air Temperature Entering Outdoor Coil																	
		48°C						50°C						51.7°C					
		Total Cool Cap.	Comp. Motor Input	Sensible To Total Ratio (S/T)			Total Cool Cap.	Comp. Motor Input	Sensible To Total Ratio (S/T)			Total Cool Cap.	Comp. Motor Input	Sensible To Total Ratio (S/T)					
				Dry Bulb					Dry Bulb					Dry Bulb					
L/s	kW	kW	24°C	27°C	29°C	kW	kW	24°C	27°C	29°C	kW	kW	24°C	27°C	29°C				
17.2°C	1135	18.1	7.12	0.84	1.00	1.00	17.5	7.38	0.86	1.00	1.00	17.0	7.61	0.87	1.00	1.00			
	1415	19.7	7.26	0.94	1.00	1.00	19.0	7.53	0.96	1.00	1.00	18.4	7.75	0.98	1.00	1.00			
	1700	20.7	7.37	1.00	1.00	1.00	20.1	7.64	1.00	1.00	1.00	19.5	7.87	1.00	1.00	1.00			
19.4°C	1135	19.0	7.21	0.64	0.86	0.99	18.3	7.46	0.64	0.87	1.00	17.7	7.69	0.65	0.88	1.00			
	1415	20.0	7.29	0.70	0.95	1.00	19.2	7.55	0.71	0.97	1.00	18.5	7.77	0.72	0.99	1.00			
	1700	20.8	7.38	0.77	1.00	1.00	20.2	7.64	0.79	1.00	1.00	19.5	7.86	0.79	1.00	1.00			
21.7°C	1135	21.1	7.39	0.38	0.58	0.71	20.3	7.65	0.38	0.58	0.72	19.5	7.88	0.37	0.59	0.72			
	1415	22.0	7.49	0.41	0.64	0.79	21.2	7.74	0.41	0.64	0.80	20.5	7.96	0.40	0.65	0.81			
	1700	22.7	7.55	0.43	0.69	0.87	21.8	7.81	0.43	0.70	0.88	21.1	8.04	0.44	0.72	0.90			

## BLOWER DATA - BELT DRIVE - KGB036 - DOWNFLOW

### BLOWER TABLE INCLUDES RESISTANCE FOR BASE UNIT ONLY WITH DRY INDOOR COIL AND AIR FILTERS IN PLACE.

FOR ALL UNITS ADD:

1 - Any factory installed options air resistance (heat section, economizer, etc.).

2 - Any field installed accessories air resistance (duct resistance, diffuser, etc.).

See page 40 for blower motors and drives and wet coil and options/accessory air resistance data.

#### External Static - Pa (in.w.g.)

Air Volume		25 (0.10)			50 (0.20)			75 (0.30)			100 (0.40)			125 (0.50)			150 (0.60)			175 (0.70)			200 (0.80)		
L/s	cfm	Rev/min	kW	BHP	Rev/min	kW	BHP	Rev/min	kW	BHP	Rev/min	kW	BHP	Rev/min	kW	BHP	Rev/min	kW	BHP	Rev/min	kW	BHP			
425	900	493	0.08	0.11	564	0.11	0.15	637	0.14	0.19	711	0.16	0.22	783	0.18	0.24	851	0.19	0.26	910	0.22	0.29	961	0.24	0.32
472	1000	517	0.10	0.14	588	0.13	0.18	660	0.16	0.22	733	0.18	0.24	804	0.19	0.26	868	0.22	0.29	924	0.24	0.32	974	0.26	0.35
519	1100	544	0.13	0.17	614	0.16	0.21	685	0.19	0.25	757	0.20	0.27	826	0.22	0.29	887	0.24	0.32	940	0.27	0.36	987	0.28	0.38
566	1200	574	0.15	0.20	643	0.18	0.24	712	0.21	0.28	782	0.23	0.31	849	0.25	0.33	906	0.27	0.36	956	0.29	0.39	1001	0.31	0.42
613	1300	613	0.17	0.23	679	0.21	0.28	745	0.23	0.31	811	0.25	0.34	873	0.27	0.36	926	0.30	0.40	973	0.32	0.43	1016	0.34	0.46
661	1400	662	0.19	0.26	722	0.22	0.30	781	0.25	0.34	841	0.28	0.37	897	0.31	0.41	944	0.33	0.44	989	0.36	0.48	1032	0.38	0.51
708	1500	710	0.22	0.29	763	0.25	0.33	816	0.28	0.38	869	0.31	0.41	919	0.34	0.45	963	0.37	0.49	1006	0.40	0.53	1049	0.42	0.56

#### External Static - Pa (in.w.g.)

Air Volume		225 (0.90)			250 (1.00)			275 (1.10)			300 (1.20)			325 (1.30)			350 (1.40)			375 (1.50)			400 (1.60)		
L/s	cfm	Rev/min	kW	BHP	Rev/min	kW	BHP	Rev/min	kW	BHP	Rev/min	kW	BHP	Rev/min	kW	BHP	Rev/min	kW	BHP	Rev/min	kW	BHP			
425	900	1008	0.25	0.34	1056	0.27	0.36	1104	0.29	0.39	1149	0.31	0.41	1190	0.33	0.44	1229	0.34	0.46	1267	0.37	0.49	1305	0.39	0.52
472	1000	1020	0.28	0.37	1067	0.30	0.40	1115	0.31	0.42	1159	0.34	0.45	1200	0.36	0.48	1239	0.38	0.51	1277	0.40	0.54	1314	0.43	0.57
519	1100	1032	0.31	0.41	1078	0.32	0.43	1124	0.34	0.46	1168	0.37	0.49	1210	0.39	0.52	1249	0.41	0.55	1286	0.43	0.58	1323	0.46	0.62
566	1200	1045	0.34	0.45	1090	0.35	0.47	1135	0.37	0.50	1178	0.40	0.53	1220	0.43	0.57	1259	0.45	0.60	1296	0.48	0.64	1332	0.50	0.67
613	1300	1060	0.37	0.49	1104	0.38	0.51	1148	0.41	0.55	1190	0.43	0.58	1230	0.46	0.62	1269	0.48	0.65	1306	0.51	0.69	1342	0.54	0.72
661	1400	1075	0.40	0.53	1119	0.42	0.56	1162	0.45	0.60	1203	0.47	0.63	1242	0.50	0.67	1280	0.53	0.71	1317	0.56	0.75	1352	0.58	0.78
708	1500	1093	0.43	0.58	1136	0.46	0.61	1177	0.48	0.65	1217	0.51	0.69	1255	0.54	0.73	1292	0.57	0.77	1328	0.60	0.80	1364	0.63	0.84

## BLOWER DATA - BELT DRIVE - KGB036 - HORIZONTAL

**BLOWER TABLE INCLUDES RESISTANCE FOR BASE UNIT ONLY WITH DRY INDOOR COIL AND AIR FILTERS IN PLACE.**

FOR ALL UNITS ADD:

1 - Any factory installed options air resistance (heat section, economizer, etc.).

2 - Any field installed accessories air resistance (duct resistance, diffuser, etc.).

See page 40 for blower motors and drives and wet coil and options/accessory air resistance data.

Air Volume		External Static - Pa (in.w.g.)																							
		25 (0.10)		50 (0.20)		75 (0.30)		100 (0.40)		125 (0.50)		150 (0.60)		175 (0.70)		200 (0.80)									
L/s	cfm	Rev/min	kW	BHP	Rev/min	kW	BHP	Rev/min	kW	BHP	Rev/min	kW	BHP	Rev/min	kW	BHP	Rev/min	kW	BHP						
425	900	465	0.07	0.09	531	0.10	0.14	0.17	600	0.13	0.17	0.20	0.22	740	0.16	0.22	808	0.18	0.24	869	0.20	0.27	925	0.22	0.30
472	1000	483	0.09	0.12	549	0.12	0.16	0.20	617	0.15	0.20	0.22	0.24	756	0.18	0.24	822	0.19	0.26	881	0.22	0.29	935	0.25	0.33
519	1100	504	0.10	0.14	570	0.14	0.19	0.22	637	0.16	0.22	0.25	0.27	773	0.20	0.27	837	0.22	0.29	894	0.24	0.32	946	0.27	0.36
566	1200	527	0.13	0.17	592	0.16	0.22	0.25	658	0.19	0.25	0.28	0.30	792	0.22	0.30	854	0.24	0.32	908	0.27	0.36	957	0.29	0.39
613	1300	552	0.15	0.20	617	0.19	0.25	0.29	682	0.22	0.29	0.31	0.33	812	0.25	0.33	871	0.27	0.36	923	0.30	0.40	970	0.32	0.43
661	1400	580	0.18	0.24	644	0.21	0.28	0.32	708	0.24	0.32	0.35	0.37	834	0.28	0.37	890	0.30	0.40	938	0.33	0.44	984	0.36	0.48
708	1500	611	0.21	0.28	674	0.24	0.32	0.35	736	0.26	0.35	0.38	0.41	857	0.31	0.41	908	0.33	0.44	954	0.37	0.49	998	0.39	0.52

### External Static - Pa (in.w.g.)

Air Volume		External Static - Pa (in.w.g.)																							
		225 (0.90)		250 (1.00)		275 (1.10)		300 (1.20)		325 (1.30)		350 (1.40)		375 (1.50)		400 (1.60)									
L/s	cfm	Rev/min	kW	BHP	Rev/min	kW	BHP	Rev/min	kW	BHP	Rev/min	kW	BHP	Rev/min	kW	BHP	Rev/min	kW	BHP						
425	900	977	0.25	0.33	1028	0.27	0.36	1079	0.29	0.39	1127	0.31	0.42	1169	0.34	0.45	1208	0.36	0.48	1246	0.38	0.51	1282	0.40	0.54
472	1000	985	0.27	0.36	1036	0.29	0.39	1087	0.31	0.42	1135	0.34	0.45	1177	0.36	0.48	1216	0.39	0.52	1253	0.41	0.55	1290	0.43	0.58
519	1100	995	0.29	0.39	1044	0.31	0.42	1093	0.34	0.45	1140	0.37	0.49	1183	0.39	0.52	1223	0.42	0.56	1261	0.44	0.59	1297	0.46	0.62
566	1200	1005	0.32	0.43	1053	0.34	0.46	1100	0.37	0.49	1146	0.40	0.53	1190	0.42	0.56	1230	0.45	0.60	1268	0.47	0.63	1304	0.50	0.67
613	1300	1016	0.35	0.47	1063	0.37	0.50	1109	0.40	0.53	1154	0.43	0.57	1197	0.46	0.61	1237	0.48	0.64	1275	0.51	0.68	1311	0.54	0.72
661	1400	1029	0.38	0.51	1074	0.40	0.54	1120	0.43	0.58	1164	0.46	0.61	1205	0.48	0.65	1245	0.51	0.69	1282	0.54	0.73	1318	0.57	0.77
708	1500	1042	0.42	0.56	1087	0.44	0.59	1132	0.46	0.62	1174	0.49	0.66	1215	0.53	0.71	1253	0.56	0.75	1290	0.58	0.78	1326	0.61	0.82

## BLOWER DATA - BELT DRIVE - KGB048 - DOWNFLOW

**BLOWER TABLE INCLUDES RESISTANCE FOR BASE UNIT ONLY WITH DRY INDOOR COIL AND AIR FILTERS IN PLACE.**

FOR ALL UNITS ADD:

- 1 - Any factory installed options air resistance (heat section, economizer, etc.);
- 2 - Any field installed accessories air resistance (duct resistance, diffuser, etc.);

See page 40 for blower motors and drives and wet coil and options/accessory air resistance data.

Air Volume		External Static - Pa (in.w.g.)																							
		25 (0.10)		50 (0.20)		75 (0.30)		100 (0.40)		125 (0.50)		150 (0.60)		175 (0.70)		200 (0.80)									
L/s	cfm	Rev/ min	kW	BHP	Rev/ min	kW	BHP	Rev/ min	kW	BHP	Rev/ min	kW	BHP	Rev/ min	kW	BHP	Rev/ min	kW	BHP						
566	1200	574	0.15	0.20	644	0.18	0.24	713	0.21	0.28	784	0.23	0.31	850	0.25	0.33	906	0.27	0.36	953	0.29	0.39	998	0.31	0.42
613	1300	608	0.18	0.24	677	0.21	0.28	744	0.23	0.31	813	0.25	0.34	874	0.28	0.37	925	0.30	0.40	969	0.32	0.43	1014	0.34	0.46
661	1400	645	0.21	0.28	712	0.23	0.31	778	0.26	0.35	842	0.28	0.38	898	0.31	0.41	944	0.33	0.44	986	0.36	0.48	1030	0.38	0.51
708	1500	684	0.23	0.31	749	0.26	0.35	811	0.28	0.38	871	0.31	0.42	921	0.34	0.45	963	0.37	0.49	1004	0.40	0.53	1048	0.42	0.56
755	1600	723	0.26	0.35	785	0.29	0.39	844	0.32	0.43	898	0.34	0.46	943	0.37	0.50	983	0.40	0.54	1024	0.43	0.58	1067	0.46	0.61
802	1700	761	0.30	0.40	819	0.33	0.44	875	0.36	0.48	924	0.39	0.52	965	0.42	0.56	1004	0.45	0.60	1045	0.47	0.63	1089	0.49	0.66
849	1800	798	0.34	0.45	853	0.37	0.49	905	0.40	0.54	950	0.43	0.58	990	0.46	0.62	1028	0.49	0.66	1069	0.51	0.69	1112	0.54	0.72
897	1900	834	0.38	0.51	885	0.41	0.55	934	0.45	0.60	977	0.48	0.64	1015	0.51	0.68	1054	0.54	0.72	1095	0.56	0.75	1137	0.59	0.79
944	2000	869	0.43	0.57	917	0.46	0.62	962	0.50	0.67	1004	0.53	0.71	1042	0.56	0.75	1081	0.58	0.78	1121	0.61	0.82	1162	0.64	0.86

Air Volume		External Static - Pa (in.w.g.)																							
		225 (0.90)		250 (1.00)		275 (1.10)		300 (1.20)		325 (1.30)		350 (1.40)		375 (1.50)		400 (1.60)									
L/s	cfm	Rev/ min	kW	BHP	Rev/ min	kW	BHP	Rev/ min	kW	BHP	Rev/ min	kW	BHP	Rev/ min	kW	BHP	Rev/ min	kW	BHP						
566	1200	1043	0.33	0.44	1090	0.35	0.47	1135	0.37	0.50	1179	0.40	0.53	1220	0.43	0.57	1259	0.45	0.60	1297	0.48	0.64	1333	0.50	0.67
613	1300	1058	0.37	0.49	1104	0.38	0.51	1148	0.41	0.55	1190	0.43	0.58	1231	0.46	0.62	1269	0.48	0.65	1306	0.51	0.69	1342	0.54	0.72
661	1400	1074	0.40	0.53	1119	0.42	0.56	1162	0.44	0.59	1203	0.47	0.63	1242	0.50	0.67	1280	0.53	0.71	1317	0.55	0.74	1352	0.58	0.78
708	1500	1092	0.43	0.58	1136	0.46	0.61	1177	0.48	0.65	1217	0.51	0.69	1255	0.54	0.73	1292	0.57	0.76	1328	0.60	0.80	1364	0.63	0.84
755	1600	1112	0.47	0.63	1154	0.50	0.67	1193	0.53	0.71	1232	0.56	0.75	1269	0.59	0.79	1306	0.62	0.83	1341	0.65	0.87	1377	0.68	0.91
802	1700	1132	0.51	0.69	1173	0.54	0.73	1211	0.57	0.77	1248	0.60	0.81	1285	0.64	0.86	1321	0.67	0.90	1356	0.70	0.94	1391	0.73	0.98
849	1800	1154	0.57	0.76	1194	0.60	0.80	1230	0.63	0.85	1266	0.66	0.89	1302	0.69	0.93	1338	0.73	0.98	1373	0.76	1.02	1408	0.79	1.06
897	1900	1178	0.62	0.83	1215	0.66	0.88	1250	0.69	0.93	1286	0.73	0.98	1321	0.76	1.02	1356	0.79	1.06	1391	0.82	1.10	1426	0.85	1.14
944	2000	1201	0.68	0.91	1237	0.72	0.97	1271	0.76	1.02	1307	0.80	1.07	1342	0.83	1.11	1376	0.86	1.15	1411	0.89	1.19	1446	0.92	1.23

## BLOWER DATA - BELT DRIVE - KGB048 - HORIZONTAL

**BLOWER TABLE INCLUDES RESISTANCE FOR BASE UNIT ONLY WITH DRY INDOOR COIL AND AIR FILTERS IN PLACE.**

FOR ALL UNITS ADD:

1 - Any factory installed options air resistance (heat section, economizer, etc.).

2 - Any field installed accessories air resistance (duct resistance, diffuser, etc.).

See page 40 for blower motors and drives and wet coil and options/accessory air resistance data.

Air Volume		External Static - Pa (in.w.g.)																					
		25 (0.10)		50 (0.20)		75 (0.30)		100 (0.40)		125 (0.50)		150 (0.60)		175 (0.70)		200 (0.80)							
L/s	cfm	Rev/min	kW	BHP	Rev/min	kW	BHP	Rev/min	kW	BHP	Rev/min	kW	BHP	Rev/min	kW	BHP	Rev/min	kW	BHP				
566	1200	540	0.13	0.18	606	0.16	0.22	0.26	748	0.22	0.29	816	0.22	0.30	870	0.25	0.33	914	0.28	0.37	961	0.30	0.40
613	1300	568	0.16	0.21	634	0.19	0.26	0.29	771	0.24	0.32	835	0.25	0.34	886	0.28	0.37	929	0.31	0.41	975	0.33	0.44
661	1400	599	0.19	0.25	664	0.22	0.29	0.33	795	0.26	0.35	855	0.28	0.38	903	0.31	0.41	946	0.34	0.45	991	0.37	0.49
708	1500	632	0.22	0.29	696	0.25	0.33	0.36	821	0.29	0.39	877	0.31	0.42	922	0.34	0.46	963	0.37	0.50	1008	0.40	0.54
755	1600	667	0.25	0.33	729	0.27	0.36	0.40	848	0.32	0.43	898	0.34	0.46	941	0.38	0.51	982	0.41	0.55	1026	0.44	0.59
802	1700	702	0.27	0.36	761	0.30	0.40	0.44	873	0.36	0.48	920	0.39	0.52	960	0.42	0.56	1001	0.46	0.61	1044	0.48	0.64
849	1800	737	0.31	0.41	794	0.34	0.45	0.49	898	0.40	0.53	941	0.43	0.58	981	0.46	0.62	1021	0.49	0.66	1064	0.52	0.70
897	1900	771	0.34	0.46	825	0.37	0.50	0.54	923	0.44	0.59	964	0.48	0.64	1002	0.51	0.68	1043	0.54	0.72	1085	0.57	0.76
944	2000	805	0.38	0.51	857	0.42	0.56	0.61	948	0.49	0.66	987	0.53	0.71	1025	0.56	0.75	1065	0.59	0.79	1107	0.61	0.82

Air Volume		External Static - Pa (in.w.g.)																							
		225 (0.90)		250 (1.00)		275 (1.10)		300 (1.20)		325 (1.30)		350 (1.40)		375 (1.50)		400 (1.60)									
L/s	cfm	Rev/min	kW	BHP	Rev/min	kW	BHP	Rev/min	kW	BHP	Rev/min	kW	BHP	Rev/min	kW	BHP	Rev/min	kW	BHP						
566	1200	1010	0.32	0.43	1061	0.34	0.46	1110	0.37	0.50	1156	0.40	0.53	1199	0.43	0.57	1239	0.46	0.61	1276	0.48	0.64	1312	0.51	0.68
613	1300	1024	0.35	0.47	1073	0.37	0.50	1120	0.40	0.54	1165	0.43	0.58	1207	0.46	0.62	1246	0.48	0.65	1284	0.51	0.69	1320	0.54	0.73
661	1400	1038	0.39	0.52	1086	0.41	0.55	1131	0.44	0.59	1175	0.46	0.62	1216	0.49	0.66	1255	0.52	0.70	1292	0.55	0.74	1328	0.58	0.78
708	1500	1054	0.43	0.57	1100	0.45	0.60	1144	0.48	0.64	1186	0.51	0.68	1226	0.54	0.72	1264	0.56	0.75	1301	0.59	0.79	1336	0.62	0.83
755	1600	1071	0.46	0.62	1116	0.48	0.65	1158	0.51	0.69	1198	0.54	0.73	1237	0.57	0.77	1274	0.60	0.81	1310	0.63	0.85	1345	0.66	0.89
802	1700	1089	0.50	0.67	1132	0.53	0.71	1172	0.56	0.75	1211	0.59	0.79	1249	0.62	0.83	1285	0.65	0.87	1321	0.68	0.91	1355	0.71	0.95
849	1800	1108	0.54	0.73	1149	0.57	0.77	1188	0.60	0.81	1225	0.63	0.85	1262	0.67	0.90	1298	0.70	0.94	1332	0.73	0.98	1366	0.75	1.01
897	1900	1128	0.59	0.79	1167	0.63	0.84	1204	0.66	0.88	1241	0.69	0.92	1276	0.72	0.97	1311	0.75	1.01	1345	0.78	1.05	1379	0.81	1.09
944	2000	1148	0.64	0.86	1186	0.68	0.91	1221	0.72	0.96	1257	0.75	1.00	1292	0.78	1.05	1326	0.81	1.09	1359	0.84	1.13	1393	0.87	1.17



## BLOWER DATA - BELT DRIVE - KGB060 - DOWNFLOW

### BLOWER TABLE INCLUDES RESISTANCE FOR BASE UNIT ONLY WITH DRY INDOOR COIL AND AIR FILTERS IN PLACE.

FOR ALL UNITS ADD:

- 1 - Any factory installed options air resistance (heat section, economizer, etc.).
- 2 - Any field installed accessories air resistance (duct resistance, diffuser, etc.).

See page 40 for blower motors and drives and wet coil and options/accessory air resistance data.

Air Volume		External Static - Pa (in.w.g.)																							
		25 (0.10)		50 (0.20)		75 (0.30)		100 (0.40)		125 (0.50)		150 (0.60)		175 (0.70)		200 (0.80)									
L/s	cfm	Rev/ min	BHP	Rev/ min	BHP	Rev/ min	BHP	Rev/ min	BHP	Rev/ min	BHP	Rev/ min	BHP	Rev/ min	BHP	Rev/ min	BHP								
755	1600	720	0.21	0.28	769	0.25	0.33	819	0.28	0.37	871	0.31	0.41	926	0.33	0.44	975	0.35	0.47	1016	0.38	0.51	1054	0.41	0.55
802	1700	779	0.22	0.30	822	0.26	0.35	864	0.29	0.39	908	0.33	0.44	953	0.36	0.48	995	0.39	0.52	1034	0.43	0.57	1072	0.46	0.61
849	1800	828	0.25	0.34	864	0.29	0.39	901	0.32	0.43	938	0.36	0.48	977	0.40	0.53	1015	0.43	0.58	1053	0.47	0.63	1091	0.50	0.67
897	1900	858	0.31	0.41	892	0.34	0.45	927	0.37	0.50	962	0.41	0.55	999	0.45	0.60	1036	0.48	0.65	1074	0.51	0.69	1112	0.54	0.73
944	2000	879	0.35	0.47	913	0.39	0.52	948	0.42	0.56	984	0.46	0.61	1020	0.50	0.67	1058	0.54	0.72	1096	0.57	0.76	1134	0.60	0.80
991	2100	900	0.40	0.53	935	0.43	0.58	970	0.47	0.63	1007	0.51	0.69	1044	0.55	0.74	1081	0.59	0.79	1119	0.63	0.84	1157	0.66	0.88
1038	2200	922	0.45	0.60	958	0.48	0.65	994	0.53	0.71	1031	0.57	0.76	1068	0.61	0.82	1106	0.65	0.87	1143	0.68	0.91	1180	0.71	0.95
1085	2300	947	0.50	0.67	983	0.54	0.73	1020	0.59	0.79	1057	0.63	0.85	1094	0.67	0.90	1131	0.71	0.95	1168	0.75	1.00	1205	0.77	1.03
1133	2400	974	0.57	0.76	1010	0.61	0.82	1047	0.66	0.88	1084	0.70	0.94	1120	0.74	0.99	1157	0.78	1.04	1193	0.81	1.08	1230	0.84	1.12

Air Volume		External Static - Pa (in.w.g.)																							
		225 (0.90)		250 (1.00)		275 (1.10)		300 (1.20)		325 (1.30)		350 (1.40)		375 (1.50)		400 (1.60)									
L/s	cfm	Rev/ min	BHP	Rev/ min	BHP	Rev/ min	BHP	Rev/ min	BHP	Rev/ min	BHP	Rev/ min	BHP	Rev/ min	BHP	Rev/ min	BHP								
755	1600	1093	0.45	0.60	1133	0.47	0.63	1173	0.50	0.67	1214	0.52	0.70	1253	0.54	0.73	1288	0.57	0.77	1318	0.60	0.81	1351	0.63	0.85
802	1700	1111	0.48	0.65	1150	0.51	0.69	1190	0.54	0.72	1230	0.57	0.76	1268	0.59	0.79	1301	0.62	0.83	1331	0.65	0.87	1363	0.69	0.92
849	1800	1130	0.53	0.71	1169	0.56	0.75	1208	0.58	0.78	1247	0.61	0.82	1285	0.64	0.86	1317	0.67	0.90	1345	0.70	0.94	1377	0.73	0.98
897	1900	1150	0.57	0.77	1188	0.60	0.81	1227	0.63	0.85	1267	0.66	0.88	1303	0.69	0.92	1333	0.72	0.97	1361	0.76	1.02	1392	0.79	1.06
944	2000	1172	0.63	0.84	1210	0.66	0.88	1248	0.69	0.92	1286	0.72	0.96	1321	0.75	1.00	1350	0.78	1.05	1377	0.82	1.10	1409	0.85	1.14
991	2100	1195	0.68	0.91	1233	0.71	0.95	1269	0.75	1.00	1306	0.78	1.04	1339	0.81	1.09	1367	0.85	1.14	1395	0.89	1.19	1426	0.92	1.23
1038	2200	1218	0.74	0.99	1255	0.77	1.03	1290	0.81	1.09	1324	0.85	1.14	1356	0.89	1.19	1385	0.93	1.24	1413	0.95	1.28	1444	0.98	1.32
1085	2300	1242	0.80	1.07	1277	0.84	1.13	1310	0.90	1.20	1343	0.94	1.26	1374	0.97	1.30	1403	1.00	1.34	1432	1.03	1.38	1464	1.06	1.42
1133	2400	1267	0.87	1.16	1300	0.92	1.23	1332	0.98	1.31	1364	1.02	1.37	1394	1.05	1.41	1423	1.08	1.45	1453	1.10	1.48	1484	1.14	1.53

## BLOWER DATA - BELT DRIVE - KGB060 - HORIZONTAL

**BLOWER TABLE INCLUDES RESISTANCE FOR BASE UNIT ONLY WITH DRY INDOOR COIL AND AIR FILTERS IN PLACE.**

FOR ALL UNITS ADD:

1 - Any factory installed options air resistance (heat section, economizer, etc.).

2 - Any field installed accessories air resistance (duct resistance, diffuser, etc.).

See page 40 for blower motors and drives and wet coil and options/accessory air resistance data.

Air Volume		External Static - Pa (in.w.g.)																							
		25 (0.10)		50 (0.20)		75 (0.30)		100 (0.40)		125 (0.50)		150 (0.60)		175 (0.70)		200 (0.80)									
L/s	cfm	Rev/ min	kW	BHP	Rev/ min	kW	BHP	Rev/ min	kW	BHP	Rev/ min	kW	BHP	Rev/ min	kW	BHP	Rev/ min	kW	BHP						
755	1600	654	0.21	0.28	712	0.24	0.32	769	0.27	0.36	825	0.29	0.39	879	0.32	0.43	933	0.35	0.47	982	0.37	0.50	1024	0.40	0.54
802	1700	703	0.23	0.31	756	0.26	0.35	807	0.29	0.39	858	0.32	0.43	906	0.35	0.47	955	0.38	0.51	999	0.41	0.55	1039	0.44	0.59
849	1800	752	0.25	0.34	798	0.28	0.38	844	0.32	0.43	889	0.36	0.48	933	0.39	0.52	977	0.43	0.57	1017	0.46	0.61	1056	0.48	0.65
897	1900	796	0.28	0.38	837	0.32	0.43	878	0.36	0.48	918	0.40	0.53	958	0.43	0.58	997	0.46	0.62	1036	0.50	0.67	1074	0.53	0.71
944	2000	833	0.32	0.43	870	0.36	0.48	907	0.40	0.54	943	0.44	0.59	980	0.48	0.64	1018	0.51	0.69	1055	0.54	0.73	1093	0.57	0.77
991	2100	864	0.37	0.50	897	0.41	0.55	931	0.45	0.60	966	0.48	0.65	1002	0.53	0.71	1038	0.57	0.76	1075	0.60	0.80	1113	0.62	0.83
1038	2200	887	0.43	0.57	920	0.46	0.62	953	0.50	0.67	988	0.54	0.73	1024	0.58	0.78	1060	0.62	0.83	1097	0.65	0.87	1135	0.67	0.90
1085	2300	909	0.48	0.64	942	0.52	0.70	976	0.56	0.75	1011	0.60	0.81	1046	0.64	0.86	1083	0.68	0.91	1120	0.71	0.95	1157	0.73	0.98
1133	2400	931	0.54	0.72	965	0.58	0.78	999	0.62	0.83	1035	0.66	0.89	1071	0.70	0.94	1108	0.74	0.99	1144	0.77	1.03	1181	0.80	1.07
Air Volume		External Static - Pa (in.w.g.)																							
		225 (0.90)		250 (1.00)		275 (1.10)		300 (1.20)		325 (1.30)		350 (1.40)		375 (1.50)		400 (1.60)									
L/s	cfm	Rev/ min	kW	BHP	Rev/ min	kW	BHP	Rev/ min	kW	BHP	Rev/ min	kW	BHP	Rev/ min	kW	BHP	Rev/ min	kW	BHP	Rev/ min	kW	BHP	Rev/ min	kW	BHP
755	1600	1063	0.43	0.58	1101	0.46	0.61	1141	0.48	0.64	1181	0.50	0.67	1222	0.52	0.70	1261	0.54	0.73	1298	0.57	0.77	1333	0.60	0.81
802	1700	1078	0.47	0.63	1117	0.49	0.66	1156	0.51	0.69	1196	0.54	0.72	1235	0.56	0.75	1273	0.59	0.79	1309	0.62	0.83	1344	0.65	0.87
849	1800	1094	0.51	0.68	1133	0.54	0.72	1172	0.56	0.75	1211	0.58	0.78	1250	0.60	0.81	1287	0.63	0.85	1322	0.67	0.90	1355	0.70	0.94
897	1900	1112	0.55	0.74	1151	0.57	0.77	1190	0.60	0.81	1228	0.63	0.84	1265	0.66	0.88	1301	0.69	0.92	1335	0.72	0.97	1367	0.75	1.01
944	2000	1131	0.60	0.80	1170	0.62	0.83	1208	0.65	0.87	1245	0.68	0.91	1281	0.72	0.96	1316	0.75	1.00	1349	0.78	1.04	1380	0.81	1.09
991	2100	1151	0.65	0.87	1189	0.67	0.90	1227	0.70	0.94	1263	0.74	0.99	1298	0.78	1.04	1331	0.81	1.08	1363	0.84	1.13	1394	0.87	1.17
1038	2200	1173	0.70	0.94	1210	0.73	0.98	1246	0.76	1.02	1281	0.80	1.07	1315	0.84	1.12	1347	0.87	1.17	1379	0.91	1.22	1409	0.94	1.26
1085	2300	1195	0.76	1.02	1231	0.79	1.06	1266	0.83	1.11	1300	0.87	1.16	1333	0.91	1.22	1364	0.95	1.27	1395	0.98	1.32	1424	1.01	1.36
1133	2400	1217	0.82	1.10	1252	0.86	1.15	1286	0.90	1.20	1319	0.94	1.26	1351	0.98	1.32	1382	1.03	1.38	1411	1.07	1.43	1440	1.10	1.48



**BLOWER DATA - BELT DRIVE - KGB074S - DOWNFLOW**

**BLOWER TABLE INCLUDES RESISTANCE FOR BASE UNIT ONLY WITH DRY INDOOR COIL AND AIR FILTERS IN PLACE.**

FOR ALL UNITS ADD:

1 - Any factory installed options air resistance (heat section, economizer, etc.).

2 - Any field installed accessories air resistance (duct resistance, diffuser, etc.).

See page 40 for blower motors and drives and wet coil and options/accessory air resistance data.

Air Volume		External Static - Pa (in.w.g.)																							
		25 (0.10)		50 (0.20)		75 (0.30)		100 (0.40)		125 (0.50)		150 (0.60)		175 (0.70)		200 (0.80)									
L/s	cfm	Rev/ min	kW	BHP	Rev/ min	kW	BHP	Rev/ min	kW	BHP	Rev/ min	kW	BHP	Rev/ min	kW	BHP	Rev/ min	kW	BHP						
897	1900	857	0.31	0.41	892	0.34	0.45	927	0.37	0.50	962	0.41	0.55	999	0.45	0.60	1036	0.48	0.65	1074	0.51	0.69	1112	0.54	0.73
944	2000	879	0.35	0.47	913	0.39	0.52	948	0.42	0.56	984	0.46	0.61	1020	0.50	0.67	1058	0.54	0.72	1096	0.57	0.76	1134	0.60	0.80
991	2100	900	0.40	0.53	935	0.43	0.58	970	0.47	0.63	1007	0.51	0.69	1044	0.55	0.74	1081	0.59	0.79	1119	0.63	0.84	1157	0.66	0.88
1038	2200	922	0.45	0.60	958	0.48	0.65	994	0.53	0.71	1031	0.57	0.76	1068	0.61	0.82	1106	0.65	0.87	1143	0.68	0.91	1180	0.71	0.95
1085	2300	947	0.50	0.67	983	0.54	0.73	1020	0.59	0.79	1057	0.63	0.85	1094	0.67	0.90	1131	0.71	0.95	1168	0.75	1.00	1205	0.77	1.03
1133	2400	974	0.57	0.76	1010	0.61	0.82	1047	0.66	0.88	1084	0.70	0.94	1120	0.74	0.99	1157	0.78	1.04	1193	0.81	1.08	1230	0.84	1.12
1180	2500	1002	0.63	0.85	1039	0.68	0.91	1075	0.72	0.97	1112	0.77	1.03	1148	0.81	1.08	1184	0.84	1.13	1220	0.87	1.17	1257	0.90	1.21
1227	2600	1032	0.71	0.95	1068	0.75	1.01	1105	0.80	1.07	1141	0.84	1.13	1177	0.87	1.17	1213	0.91	1.22	1248	0.94	1.26	1284	0.98	1.31
1274	2700	1062	0.78	1.05	1099	0.83	1.11	1136	0.87	1.17	1172	0.91	1.22	1207	0.95	1.27	1242	0.98	1.32	1277	1.02	1.37	1312	1.07	1.43
1321	2800	1094	0.87	1.16	1131	0.91	1.22	1167	0.95	1.27	1202	0.98	1.32	1237	1.03	1.38	1271	1.07	1.43	1305	1.11	1.49	1339	1.16	1.56
1369	2900	1127	0.94	1.26	1163	0.98	1.32	1198	1.03	1.38	1233	1.07	1.44	1267	1.12	1.50	1300	1.16	1.56	1334	1.22	1.64	1367	1.28	1.71
Air Volume		External Static - Pa (in.w.g.)																							
		225 (0.90)		250 (1.00)		275 (1.10)		300 (1.20)		325 (1.30)		350 (1.40)		375 (1.50)		400 (1.60)									
L/s	cfm	Rev/ min	kW	BHP	Rev/ min	kW	BHP	Rev/ min	kW	BHP	Rev/ min	kW	BHP	Rev/ min	kW	BHP	Rev/ min	kW	BHP						
897	1900	1150	0.57	0.77	1188	0.60	0.81	1227	0.63	0.85	1267	0.66	0.88	1303	0.69	0.92	1333	0.72	0.97	1360	0.76	1.02	1392	0.79	1.06
944	2000	1172	0.63	0.84	1210	0.66	0.88	1248	0.69	0.92	1286	0.72	0.96	1321	0.75	1.00	1350	0.78	1.05	1377	0.82	1.10	1409	0.85	1.14
991	2100	1195	0.68	0.91	1233	0.71	0.95	1269	0.75	1.00	1306	0.78	1.04	1339	0.81	1.09	1367	0.85	1.14	1395	0.89	1.19	1426	0.92	1.23
1038	2200	1218	0.74	0.99	1255	0.77	1.03	1290	0.81	1.09	1324	0.85	1.14	1356	0.89	1.19	1385	0.93	1.24	1413	0.95	1.28	1444	0.98	1.32
1085	2300	1242	0.80	1.07	1277	0.84	1.13	1310	0.90	1.20	1343	0.94	1.26	1374	0.97	1.30	1403	1.00	1.34	1432	1.03	1.38	1464	1.06	1.42
1133	2400	1267	0.87	1.16	1300	0.92	1.23	1332	0.98	1.31	1364	1.02	1.37	1394	1.05	1.41	1423	1.08	1.45	1453	1.10	1.48	1484	1.14	1.53
1180	2500	1292	0.94	1.26	1324	1.00	1.34	1355	1.06	1.42	1387	1.10	1.48	1417	1.13	1.52	1445	1.16	1.56	1475	1.19	1.59	1506	1.22	1.64
1227	2600	1318	1.03	1.38	1350	1.09	1.46	1380	1.16	1.55	1411	1.19	1.60	1440	1.22	1.64	1469	1.25	1.68	1498	1.28	1.71	1529	1.31	1.76
1274	2700	1345	1.13	1.51	1376	1.19	1.60	1406	1.25	1.68	1436	1.29	1.73	1465	1.32	1.77	1493	1.34	1.80	1523	1.37	1.84	1553	1.40	1.88
1321	2800	1372	1.23	1.65	1403	1.30	1.74	1433	1.36	1.82	1462	1.39	1.86	1490	1.42	1.90	1519	1.44	1.93	1548	1.47	1.97	1578	1.50	2.01
1369	2900	1399	1.34	1.80	1430	1.41	1.89	1460	1.46	1.96	1489	1.49	2.00	1516	1.51	2.03	1544	1.54	2.06	1573	1.57	2.10	1603	1.60	2.14

## BLOWER DATA - BELT DRIVE - KGB074S - HORIZONTAL

**BLOWER TABLE INCLUDES RESISTANCE FOR BASE UNIT ONLY WITH DRY INDOOR COIL AND AIR FILTERS IN PLACE.**  
FOR ALL UNITS ADD:

- 1 - Any factory installed options air resistance (heat section, economizer, etc.).
  - 2 - Any field installed accessories air resistance (duct resistance, diffuser, etc.).
- See page 40 for blower motors and drives and wet coil and options/accessory air resistance data.

Air Volume		External Static - Pa (in.w.g.)																				
		25 (0.10)		50 (0.20)		75 (0.30)		100 (0.40)		125 (0.50)		150 (0.60)		175 (0.70)		200 (0.80)						
L/s	cfm	Rev/ min	BHP	kW	Rev/ min	BHP	kW	Rev/ min	BHP	kW	Rev/ min	BHP	kW	Rev/ min	BHP	kW	Rev/ min	BHP	kW	Rev/ min	BHP	
897	1900	796	0.28	0.32	0.38	0.43	0.36	0.48	0.53	0.43	0.58	0.62	0.46	0.62	0.50	0.67	1074	0.53	0.71	1074	0.53	0.71
944	2000	833	0.32	0.36	0.43	0.48	0.40	0.54	0.59	0.48	0.64	0.69	0.51	0.69	0.54	0.73	1093	0.57	0.77	1093	0.57	0.77
991	2100	864	0.37	0.41	0.50	0.55	0.45	0.60	0.65	0.53	0.71	0.76	0.57	0.76	0.60	0.80	1113	0.62	0.83	1113	0.62	0.83
1038	2200	887	0.43	0.46	0.57	0.62	0.50	0.67	0.73	0.58	0.78	0.83	0.62	0.83	0.65	0.87	1135	0.67	0.90	1135	0.67	0.90
1085	2300	909	0.48	0.52	0.64	0.70	0.56	0.75	0.81	0.64	0.86	0.91	0.68	0.91	0.71	0.95	1157	0.73	0.98	1157	0.73	0.98
1133	2400	931	0.54	0.58	0.72	0.78	0.62	0.83	0.89	0.70	0.94	0.99	0.74	0.99	0.77	1.03	1181	0.80	1.07	1181	0.80	1.07
1180	2500	955	0.60	0.64	0.80	0.86	0.69	0.92	0.98	0.77	1.03	1.08	0.81	1.08	0.83	1.11	1205	0.86	1.15	1205	0.86	1.15
1227	2600	981	0.67	0.72	0.90	0.96	0.75	1.01	1.07	0.84	1.12	1.16	0.87	1.16	0.90	1.20	1230	0.93	1.25	1230	0.93	1.25
1274	2700	1009	0.74	0.78	0.99	1.05	0.83	1.11	1.16	0.90	1.21	1.24	0.94	1.24	0.97	1.30	1254	1.01	1.35	1254	1.01	1.35
1321	2800	1038	0.82	0.87	1.10	1.16	0.90	1.21	1.26	0.98	1.31	1.36	1.01	1.36	1.04	1.40	1279	1.09	1.46	1279	1.09	1.46
1369	2900	1068	0.90	0.94	1.20	1.26	0.98	1.31	1.36	1.05	1.41	1.47	1.10	1.47	1.13	1.52	1304	1.18	1.58	1304	1.18	1.58

Air Volume		External Static - Pa (in.w.g.)																				
		225 (0.90)		250 (1.00)		275 (1.10)		300 (1.20)		325 (1.30)		350 (1.40)		375 (1.50)		400 (1.60)						
L/s	cfm	Rev/ min	BHP	kW	Rev/ min	BHP	kW	Rev/ min	BHP	kW	Rev/ min	BHP	kW	Rev/ min	BHP	kW	Rev/ min	BHP	kW	Rev/ min	BHP	
897	1900	1112	0.55	0.57	0.74	0.77	0.60	0.81	0.84	0.66	0.88	0.92	0.69	0.92	0.72	0.97	1367	0.75	1.01	1367	0.75	1.01
944	2000	1131	0.60	0.62	0.80	0.83	0.65	0.87	0.91	0.72	0.96	1.00	0.75	1.00	0.78	1.04	1380	0.81	1.09	1380	0.81	1.09
991	2100	1151	0.65	0.67	0.87	0.90	0.70	0.94	0.99	0.78	1.04	1.08	0.81	1.08	0.84	1.13	1394	0.87	1.17	1394	0.87	1.17
1038	2200	1173	0.70	0.73	0.94	0.98	0.76	1.02	1.07	0.84	1.12	1.17	0.87	1.17	0.91	1.22	1409	0.94	1.26	1409	0.94	1.26
1085	2300	1195	0.76	0.79	1.02	1.06	0.83	1.11	1.16	0.91	1.22	1.27	0.95	1.27	0.98	1.32	1424	1.01	1.36	1424	1.01	1.36
1133	2400	1217	0.82	0.86	1.10	1.15	0.90	1.20	1.26	0.98	1.32	1.38	1.03	1.38	1.07	1.43	1440	1.10	1.48	1440	1.10	1.48
1180	2500	1240	0.90	0.93	1.20	1.25	0.98	1.31	1.37	1.07	1.43	1.49	1.11	1.49	1.16	1.55	1457	1.19	1.59	1457	1.19	1.59
1227	2600	1264	0.97	1.01	1.30	1.35	1.06	1.42	1.49	1.16	1.55	1.61	1.20	1.61	1.25	1.67	1475	1.28	1.72	1475	1.28	1.72
1274	2700	1287	1.04	1.10	1.40	1.47	1.15	1.54	1.61	1.25	1.68	1.74	1.30	1.74	1.34	1.79	1493	1.37	1.84	1493	1.37	1.84
1321	2800	1311	1.13	1.19	1.52	1.59	1.24	1.66	1.74	1.34	1.80	1.87	1.40	1.87	1.43	1.92	1513	1.47	1.97	1513	1.47	1.97
1369	2900	1335	1.23	1.28	1.65	1.72	1.34	1.79	1.87	1.45	1.94	2.00	1.49	2.00	1.53	2.05	1533	1.56	2.09	1533	1.56	2.09

## BLOWER DATA - BELT DRIVE - KGB072H/KGB074H - DOWNFLOW

### BLOWER TABLE INCLUDES RESISTANCE FOR BASE UNIT ONLY WITH DRY INDOOR COIL AND AIR FILTERS IN PLACE.

FOR ALL UNITS ADD:

1 - Any factory installed options air resistance (heat section, economizer, etc.).

2 - Any field installed accessories air resistance (duct resistance, diffuser, etc.).

See page 40 for blower motors and drives and wet coil and options/accessory air resistance data.

Air Volume		External Static - Pa (in. w.g.)																													
		25 (0.10)		50 (0.20)		75 (0.30)		100 (0.40)		125 (0.50)		150 (0.60)		175 (0.70)		200 (0.80)		225 (0.90)		250 (1.00)											
L/s	cfm	Rev/ min	kW	BHP	Rev/ min	kW	BHP	Rev/ min	kW	BHP	Rev/ min	kW	BHP	Rev/ min	kW	BHP	Rev/ min	kW	BHP	Rev/ min	kW	BHP									
897	1900	523	0.35	0.47	557	0.4	0.53	591	0.44	0.59	625	0.48	0.64	660	0.51	0.68	694	0.54	0.72	730	0.57	0.76	764	0.59	0.8	796	0.63	0.84	824	0.66	0.89
944	2000	540	0.38	0.51	574	0.43	0.57	608	0.47	0.63	643	0.51	0.68	677	0.54	0.72	710	0.57	0.76	745	0.6	0.8	777	0.63	0.84	807	0.66	0.89	834	0.7	0.94
991	2100	559	0.42	0.56	592	0.46	0.61	626	0.5	0.67	660	0.54	0.72	694	0.57	0.77	727	0.6	0.81	760	0.63	0.85	790	0.67	0.89	819	0.7	0.94	844	0.74	1
1038	2200	578	0.45	0.6	611	0.49	0.66	645	0.53	0.71	678	0.57	0.76	711	0.61	0.81	743	0.64	0.86	775	0.67	0.9	804	0.71	0.95	830	0.75	1	855	0.79	1.06
1085	2300	599	0.49	0.65	632	0.53	0.71	664	0.57	0.76	697	0.6	0.81	729	0.64	0.86	760	0.68	0.91	790	0.72	0.96	817	0.76	1.01	842	0.8	1.07	867	0.84	1.12
1133	2400	621	0.53	0.71	652	0.57	0.76	684	0.61	0.81	716	0.65	0.86	746	0.68	0.92	776	0.72	0.97	805	0.76	1.02	830	0.81	1.08	855	0.85	1.14	879	0.89	1.19
1180	2500	642	0.57	0.77	673	0.61	0.82	704	0.65	0.87	734	0.69	0.93	764	0.73	0.98	793	0.77	1.04	820	0.82	1.09	845	0.86	1.15	868	0.9	1.21	892	0.94	1.27
1227	2600	665	0.61	0.82	694	0.65	0.88	724	0.7	0.93	753	0.74	0.99	782	0.78	1.05	810	0.83	1.11	835	0.87	1.17	859	0.92	1.23	883	0.96	1.29	907	1	1.34
1274	2700	688	0.66	0.89	716	0.7	0.94	744	0.75	1	773	0.79	1.06	800	0.84	1.13	827	0.89	1.19	851	0.93	1.25	875	0.98	1.31	898	1.02	1.37	922	1.06	1.42
1321	2800	710	0.71	0.95	738	0.76	1.02	765	0.81	1.08	792	0.85	1.15	818	0.9	1.21	844	0.95	1.28	868	1	1.34	891	1.04	1.4	914	1.08	1.45	938	1.12	1.51
1369	2900	733	0.77	1.03	759	0.82	1.1	785	0.87	1.17	811	0.92	1.24	836	0.97	1.3	861	1.02	1.37	885	1.07	1.43	908	1.11	1.49	931	1.15	1.54	954	1.19	1.59

Air Volume		External Static - Pa (in. w.g.)																													
		275 (1.10)		300 (1.20)		325 (1.30)		350 (1.40)		375 (1.50)		400 (1.60)		425 (1.70)		450 (1.80)		475 (1.90)		500 (2.00)											
L/s	cfm	Rev/ min	kW	BHP	Rev/ min	kW	BHP	Rev/ min	kW	BHP	Rev/ min	kW	BHP	Rev/ min	kW	BHP	Rev/ min	kW	BHP	Rev/ min	kW	BHP									
897	1900	851	0.7	0.94	878	0.73	0.98	904	0.76	1.03	930	0.8	1.07	957	0.83	1.11	984	0.86	1.15	1010	0.9	1.2	1035	0.94	1.25	1060	0.98	1.31	1084	1.02	1.37
944	2000	860	0.74	0.99	886	0.77	1.04	913	0.81	1.08	939	0.84	1.12	966	0.87	1.17	992	0.9	1.21	1018	0.94	1.26	1043	0.98	1.32	1067	1.03	1.38	1090	1.07	1.43
991	2100	870	0.78	1.05	896	0.82	1.1	922	0.85	1.14	948	0.88	1.18	975	0.92	1.23	1001	0.95	1.27	1027	0.99	1.33	1051	1.03	1.39	1074	1.08	1.44	1097	1.12	1.5
1038	2200	880	0.83	1.11	906	0.86	1.16	932	0.9	1.2	959	0.93	1.25	985	0.96	1.29	1011	1	1.34	1036	1.04	1.4	1059	1.09	1.46	1082	1.13	1.52	1105	1.18	1.58
1085	2300	891	0.88	1.18	917	0.91	1.22	943	0.95	1.27	970	0.98	1.31	996	1.02	1.36	1021	1.05	1.41	1046	1.1	1.47	1068	1.14	1.53	1090	1.19	1.6	1113	1.24	1.66
1133	2400	904	0.93	1.25	929	0.97	1.29	956	1	1.34	982	1.03	1.39	1008	1.07	1.43	1032	1.11	1.49	1056	1.16	1.55	1078	1.21	1.62	1099	1.25	1.68	1121	1.3	1.75
1180	2500	917	0.98	1.32	942	1.02	1.37	968	1.05	1.41	994	1.09	1.46	1020	1.13	1.51	1044	1.17	1.57	1066	1.22	1.64	1088	1.27	1.7	1108	1.32	1.77	1130	1.37	1.84
1227	2600	931	1.04	1.39	957	1.08	1.44	982	1.11	1.49	1008	1.15	1.54	1032	1.19	1.6	1055	1.24	1.66	1077	1.29	1.73	1098	1.34	1.8	1118	1.4	1.87	1139	1.45	1.94
1274	2700	946	1.1	1.47	971	1.14	1.52	996	1.17	1.57	1021	1.21	1.63	1045	1.26	1.69	1067	1.31	1.76	1088	1.37	1.83	1108	1.42	1.91	1127	1.48	1.98	1148	1.53	2.05
1321	2800	962	1.16	1.56	986	1.2	1.61	1011	1.24	1.66	1034	1.28	1.72	1057	1.33	1.79	1079	1.39	1.86	1099	1.45	1.94	1118	1.51	2.02	1137	1.56	2.09	1158	1.61	2.16
1369	2900	978	1.23	1.65	1001	1.27	1.7	1025	1.31	1.75	1048	1.36	1.82	1069	1.41	1.89	1090	1.47	1.98	1109	1.54	2.06	1128	1.6	2.14	1147	1.65	2.22	1167	1.7	2.28

## BLOWER DATA - BELT DRIVE - KGB072H/KGB074H - HORIZONTAL

**BLOWER TABLE INCLUDES RESISTANCE FOR BASE UNIT ONLY WITH DRY INDOOR COIL AND AIR FILTERS IN PLACE. FOR ALL UNITS ADD:**

- 1 - Any factory installed options air resistance (heat section, economizer, etc.).
- 2 - Any field installed accessories air resistance (duct resistance, diffuser, etc.).

See page 40 for blower motors and drives and wet coil and options/accessory air resistance data.

Air Volume		External Static - Pa (in.w.g.)																													
		25 (0.10)		50 (0.20)		75 (0.30)		100 (0.40)		125 (0.50)		150 (0.60)		175 (0.70)		200 (0.80)		225 (0.90)		250 (1.00)											
L/s	cfm	Rev/ min	kW	BHP	Rev/ min	kW	BHP	Rev/ min	kW	BHP	Rev/ min	kW	BHP	Rev/ min	kW	BHP	Rev/ min	kW	BHP	Rev/ min	kW	BHP									
897	1900	490	0.38	0.5	521	0.4	0.53	554	0.42	0.56	588	0.45	0.6	622	0.47	0.63	656	0.5	0.67	690	0.53	0.71	725	0.56	0.75	759	0.59	0.79	790	0.62	0.83
944	2000	505	0.41	0.55	537	0.43	0.58	569	0.45	0.61	602	0.48	0.64	636	0.51	0.68	669	0.53	0.71	702	0.56	0.75	736	0.59	0.79	769	0.62	0.84	798	0.66	0.88
991	2100	521	0.44	0.6	552	0.47	0.62	584	0.49	0.66	617	0.51	0.69	650	0.54	0.73	682	0.57	0.76	715	0.6	0.8	747	0.63	0.84	778	0.66	0.89	807	0.7	0.93
1038	2200	537	0.48	0.65	569	0.5	0.68	600	0.53	0.71	632	0.55	0.74	665	0.58	0.78	696	0.61	0.81	728	0.64	0.85	759	0.67	0.9	789	0.7	0.94	816	0.74	0.99
1085	2300	554	0.52	0.7	585	0.54	0.73	617	0.57	0.76	648	0.59	0.79	680	0.62	0.83	711	0.65	0.87	741	0.68	0.91	771	0.71	0.95	799	0.75	1	826	0.78	1.05
1133	2400	572	0.56	0.75	602	0.58	0.78	633	0.61	0.81	664	0.63	0.85	695	0.66	0.88	725	0.69	0.92	755	0.72	0.97	784	0.75	1.01	811	0.79	1.06	836	0.83	1.11
1180	2500	591	0.6	0.8	620	0.62	0.83	650	0.65	0.87	680	0.67	0.9	711	0.7	0.94	740	0.73	0.98	769	0.77	1.03	797	0.8	1.08	823	0.84	1.13	847	0.88	1.18
1227	2600	610	0.64	0.86	639	0.66	0.89	668	0.69	0.92	697	0.72	0.96	727	0.75	1	755	0.78	1.05	783	0.82	1.09	810	0.85	1.14	835	0.89	1.2	859	0.93	1.25
1274	2700	630	0.68	0.91	658	0.71	0.95	686	0.73	0.98	715	0.76	1.02	743	0.8	1.07	771	0.83	1.11	798	0.87	1.16	824	0.91	1.22	848	0.95	1.27	872	0.99	1.32
1321	2800	650	0.73	0.97	677	0.75	1.01	705	0.78	1.05	732	0.81	1.09	760	0.85	1.14	787	0.89	1.19	813	0.93	1.24	838	0.97	1.3	861	1.01	1.35	885	1.05	1.4
1369	2900	670	0.77	1.03	697	0.8	1.07	724	0.83	1.11	750	0.87	1.16	777	0.9	1.21	803	0.95	1.27	828	0.99	1.32	852	1.03	1.38	876	1.07	1.44	898	1.11	1.49

Air Volume		External Static - Pa (in.w.g.)																													
		275 (1.10)		300 (1.20)		325 (1.30)		350 (1.40)		375 (1.50)		400 (1.60)		425 (1.70)		450 (1.80)		475 (1.90)		500 (2.00)											
L/s	cfm	Rev/ min	kW	BHP	Rev/ min	kW	BHP	Rev/ min	kW	BHP	Rev/ min	kW	BHP	Rev/ min	kW	BHP	Rev/ min	kW	BHP	Rev/ min	kW	BHP	Rev/ min	kW	BHP	Rev/ min	kW	BHP	Rev/ min	kW	BHP
897	1900	818	0.66	0.88	843	0.69	0.92	869	0.72	0.97	896	0.75	1.01	924	0.79	1.05	953	0.82	1.1	981	0.85	1.14	1008	0.89	1.19	1034	0.93	1.24	1059	0.96	1.29
944	2000	825	0.69	0.93	850	0.73	0.97	875	0.76	1.02	902	0.79	1.06	930	0.83	1.11	958	0.86	1.15	986	0.89	1.2	1012	0.93	1.25	1038	0.97	1.3	1061	1.01	1.35
991	2100	833	0.73	0.98	857	0.77	1.03	883	0.8	1.07	910	0.83	1.12	937	0.87	1.16	965	0.9	1.21	991	0.94	1.26	1017	0.98	1.31	1041	1.02	1.37	1064	1.06	1.42
1038	2200	841	0.77	1.04	866	0.81	1.09	891	0.84	1.13	918	0.88	1.18	945	0.91	1.22	972	0.95	1.27	998	0.99	1.32	1022	1.03	1.38	1045	1.07	1.44	1067	1.11	1.49
1085	2300	851	0.82	1.1	875	0.85	1.15	901	0.89	1.19	927	0.92	1.24	954	0.96	1.29	980	1	1.34	1004	1.04	1.39	1028	1.08	1.45	1050	1.13	1.51	1071	1.17	1.57
1133	2400	861	0.87	1.16	886	0.9	1.21	911	0.94	1.26	937	0.97	1.3	963	1.01	1.35	988	1.05	1.41	1012	1.09	1.47	1034	1.14	1.53	1055	1.19	1.59	1076	1.23	1.65
1180	2500	872	0.92	1.23	896	0.95	1.27	921	0.99	1.32	947	1.02	1.37	972	1.06	1.43	997	1.11	1.48	1019	1.15	1.55	1041	1.2	1.61	1061	1.25	1.68	1081	1.3	1.74
1227	2600	883	0.97	1.3	908	1	1.35	933	1.04	1.4	958	1.08	1.45	982	1.12	1.5	1006	1.17	1.57	1027	1.22	1.63	1048	1.27	1.7	1068	1.32	1.77	1087	1.36	1.83
1274	2700	895	1.02	1.37	920	1.06	1.42	944	1.1	1.47	969	1.14	1.53	992	1.19	1.59	1015	1.23	1.65	1036	1.29	1.72	1056	1.34	1.79	1075	1.39	1.86	1094	1.44	1.92
1321	2800	908	1.08	1.45	932	1.12	1.5	956	1.16	1.56	980	1.21	1.62	1003	1.25	1.68	1025	1.3	1.75	1045	1.36	1.82	1064	1.41	1.89	1083	1.46	1.96	1102	1.51	2.02
1369	2900	922	1.15	1.54	945	1.19	1.59	969	1.23	1.65	992	1.27	1.71	1014	1.33	1.78	1035	1.38	1.85	1055	1.43	1.92	1074	1.49	2	1092	1.54	2.07	1111	1.59	2.13



**BLOWER DATA - BELT DRIVE - KGB090S4 - DOWNFLOW**

**BLOWER TABLE INCLUDES RESISTANCE FOR BASE UNIT ONLY WITH DRY INDOOR COIL AND AIR FILTERS IN PLACE. FOR ALL UNITS ADD:**

- 1 - Any factory installed options air resistance (heat section, economizer, etc.).
  - 2 - Any field installed accessories air resistance (duct resistance, diffuser, etc.).
- See page 40 for blower motors and drives and wet coil and options/accessory air resistance data.

Air Volume		External Static - Pa (in. w.g.)																													
		25 (0.10)		50 (0.20)		75 (0.30)		100 (0.40)		125 (0.50)		150 (0.60)		175 (0.70)		200 (0.80)		225 (0.90)		250 (1.00)											
L/s	CFM	Rev/min	kW	BHP	Rev/min	kW	BHP	Rev/min	kW	BHP	Rev/min	kW	BHP	Rev/min	kW	BHP	Rev/min	kW	BHP	Rev/min	kW	BHP									
1133	2400	621	0.53	0.71	652	0.57	0.76	684	0.60	0.81	716	0.64	0.86	746	0.69	0.92	776	0.72	0.97	805	0.76	1.02	830	0.81	1.08	855	0.85	1.14	879	0.89	1.19
1180	2500	642	0.57	0.77	673	0.61	0.82	704	0.65	0.87	734	0.69	0.93	764	0.73	0.98	793	0.78	1.04	820	0.81	1.09	845	0.86	1.15	868	0.90	1.21	892	0.95	1.27
1227	2600	665	0.61	0.82	694	0.66	0.88	724	0.69	0.93	753	0.74	0.99	782	0.78	1.05	810	0.83	1.11	835	0.87	1.17	859	0.92	1.23	883	0.96	1.29	907	1.00	1.34
1274	2700	688	0.66	0.89	716	0.70	0.94	744	0.75	1.00	773	0.79	1.06	800	0.84	1.13	827	0.89	1.19	851	0.93	1.25	875	0.98	1.31	898	1.02	1.37	922	1.06	1.42
1321	2800	710	0.71	0.95	738	0.76	1.02	765	0.81	1.08	792	0.86	1.15	818	0.90	1.21	844	0.95	1.28	868	1.00	1.34	891	1.04	1.40	914	1.08	1.45	938	1.13	1.51
1369	2900	733	0.77	1.03	759	0.82	1.10	785	0.87	1.17	811	0.93	1.24	836	0.97	1.30	861	1.02	1.37	885	1.07	1.43	908	1.11	1.49	931	1.15	1.54	954	1.19	1.59
1416	3000	754	0.84	1.12	779	0.89	1.19	805	0.94	1.26	830	0.99	1.33	855	1.04	1.40	879	1.09	1.46	902	1.13	1.52	925	1.18	1.58	948	1.22	1.63	970	1.26	1.69
1463	3100	775	0.91	1.22	800	0.96	1.29	824	1.01	1.36	849	1.07	1.43	873	1.12	1.50	897	1.16	1.56	920	1.21	1.62	942	1.25	1.67	964	1.29	1.73	987	1.33	1.78
1510	3200	796	0.98	1.32	820	1.04	1.39	844	1.10	1.47	868	1.14	1.53	892	1.19	1.60	915	1.24	1.66	937	1.28	1.72	959	1.32	1.77	981	1.37	1.83	1002	1.40	1.88
1557	3300	816	1.07	1.43	840	1.12	1.50	863	1.17	1.57	887	1.22	1.64	910	1.27	1.70	933	1.31	1.76	955	1.36	1.82	976	1.40	1.88	997	1.44	1.93	1018	1.48	1.99
1604	3400	837	1.15	1.54	860	1.20	1.61	883	1.25	1.68	906	1.31	1.75	929	1.35	1.81	951	1.40	1.87	972	1.44	1.93	993	1.48	1.98	1013	1.53	2.05	1033	1.57	2.11
1652	3500	858	1.24	1.66	881	1.29	1.73	903	1.34	1.79	926	1.39	1.86	948	1.43	1.92	969	1.48	1.98	990	1.52	2.04	1009	1.57	2.10	1029	1.62	2.17	1048	1.67	2.24
1699	3600	879	1.32	1.77	901	1.37	1.84	923	1.42	1.91	945	1.47	1.97	966	1.52	2.04	987	1.57	2.10	1006	1.61	2.16	1025	1.66	2.23	1044	1.72	2.30	1062	1.78	2.38

Air Volume		External Static - Pa (in. w.g.)																													
		275 (1.10)		300 (1.20)		325 (1.30)		350 (1.40)		375 (1.50)		400 (1.60)		425 (1.70)		450 (1.80)		475 (1.90)		500 (2.00)											
L/s	CFM	Rev/min	kW	BHP	Rev/min	kW	BHP	Rev/min	kW	BHP	Rev/min	kW	BHP	Rev/min	kW	BHP	Rev/min	kW	BHP	Rev/min	kW	BHP	Rev/min	kW	BHP	Rev/min	kW	BHP	Rev/min	kW	BHP
1133	2400	904	0.93	1.25	929	0.96	1.29	956	1.00	1.34	982	1.04	1.39	1008	1.07	1.43	1032	1.11	1.49	1056	1.16	1.55	1078	1.21	1.62	1099	1.25	1.68	1121	1.31	1.75
1180	2500	917	0.98	1.32	942	1.02	1.37	968	1.05	1.41	994	1.09	1.46	1020	1.13	1.51	1044	1.17	1.57	1066	1.22	1.64	1088	1.27	1.70	1108	1.32	1.77	1130	1.37	1.84
1227	2600	931	1.04	1.39	957	1.07	1.44	982	1.11	1.49	1008	1.15	1.54	1032	1.19	1.60	1055	1.24	1.66	1077	1.29	1.73	1098	1.34	1.80	1118	1.40	1.87	1139	1.45	1.94
1274	2700	946	1.10	1.47	971	1.13	1.52	996	1.17	1.57	1021	1.22	1.63	1045	1.26	1.69	1067	1.31	1.76	1088	1.37	1.83	1108	1.42	1.91	1127	1.48	1.98	1148	1.53	2.05
1321	2800	962	1.16	1.56	986	1.20	1.61	1011	1.24	1.66	1034	1.28	1.72	1057	1.34	1.79	1079	1.39	1.86	1099	1.45	1.94	1118	1.51	2.02	1137	1.56	2.09	1158	1.61	2.16
1369	2900	978	1.23	1.65	1001	1.27	1.70	1025	1.31	1.75	1048	1.36	1.82	1069	1.41	1.89	1090	1.48	1.98	1109	1.54	2.06	1128	1.60	2.14	1147	1.66	2.22	1167	1.70	2.28
1416	3000	993	1.30	1.74	1016	1.34	1.79	1039	1.39	1.86	1061	1.44	1.93	1081	1.50	2.01	1101	1.57	2.10	1120	1.63	2.18	1138	1.69	2.27	1157	1.75	2.34	1177	1.80	2.41
1463	3100	1009	1.37	1.84	1031	1.42	1.90	1052	1.47	1.97	1073	1.53	2.05	1093	1.59	2.13	1112	1.66	2.22	1130	1.72	2.31	1148	1.79	2.40	1167	1.84	2.47	1187	1.89	2.53
1510	3200	1024	1.45	1.94	1045	1.50	2.01	1065	1.56	2.09	1085	1.62	2.17	1104	1.69	2.26	1123	1.76	2.36	1141	1.83	2.45	1159	1.89	2.53	1178	1.94	2.60	1198	1.98	2.66
1557	3300	1038	1.54	2.06	1058	1.59	2.13	1078	1.66	2.22	1097	1.72	2.31	1116	1.79	2.40	1134	1.86	2.49	1152	1.92	2.58	1170	1.98	2.66	1189	2.04	2.73	1209	2.08	2.79
1604	3400	1053	1.63	2.19	1072	1.69	2.27	1091	1.75	2.35	1109	1.83	2.45	1127	1.89	2.54	1145	1.96	2.63	1163	2.03	2.72	1181	2.08	2.79	1200	2.13	2.86	1220	2.18	2.92
1652	3500	1067	1.73	2.32	1085	1.80	2.41	1103	1.87	2.50	1121	1.93	2.59	1138	2.01	2.69	1156	2.07	2.78	1174	2.13	2.85	1192	2.19	2.93	1212	2.23	2.99	1231	2.28	3.05
1699	3600	1081	1.84	2.46	1098	1.90	2.55	1116	1.97	2.64	1133	2.04	2.74	1151	2.11	2.83	1168	2.17	2.91	1186	2.23	2.99	1205	2.28	3.06	1224	2.33	3.12	1243	2.36	3.17

**BLOWER DATA - BELT DRIVE - KGB090S4 - HORIZONTAL****BLOWER TABLE INCLUDES RESISTANCE FOR BASE UNIT ONLY WITH DRY INDOOR COIL AND AIR FILTERS IN PLACE.**

FOR ALL UNITS ADD:

1 - Any factory installed options air resistance (heat section, economizer, etc.).

2 - Any field installed accessories air resistance (duct resistance, diffuser, etc.).

See page 40 for blower motors and drives and wet coil and options/accessory air resistance data.

Air Volume		External Static - Pa (in. w.g.)																															
		25 (0.10)			50 (0.20)			75 (0.30)			100 (0.40)			125 (0.50)			150 (0.60)			175 (0.70)			200 (0.80)			225 (0.90)			250 (1.00)				
		Rev/ min	kW BHP	CFM	Rev/ min	kW BHP	CFM	Rev/ min	kW BHP	CFM	Rev/ min	kW BHP	CFM	Rev/ min	kW BHP	CFM	Rev/ min	kW BHP	CFM	Rev/ min	kW BHP	CFM	Rev/ min	kW BHP	CFM	Rev/ min	kW BHP	CFM					
		1133	2400	572	0.56	0.75	602	0.58	0.78	633	0.60	0.81	664	0.63	0.85	695	0.66	0.88	725	0.69	0.92	755	0.72	0.97	784	0.75	1.01	811	0.79	1.06	836	0.83	1.11
		1180	2500	591	0.60	0.80	620	0.62	0.83	650	0.65	0.87	680	0.67	0.90	711	0.70	0.94	740	0.73	0.98	769	0.77	1.03	797	0.81	1.08	823	0.84	1.13	847	0.88	1.18
		1227	2600	610	0.64	0.86	639	0.66	0.89	668	0.69	0.92	697	0.72	0.96	727	0.75	1.00	755	0.78	1.05	783	0.81	1.09	810	0.85	1.14	835	0.90	1.20	859	0.93	1.25
		1274	2700	630	0.68	0.91	658	0.71	0.95	686	0.73	0.98	715	0.76	1.02	743	0.80	1.07	771	0.83	1.11	798	0.87	1.16	824	0.91	1.22	848	0.95	1.27	872	0.98	1.32
		1321	2800	650	0.72	0.97	677	0.75	1.01	705	0.78	1.05	732	0.81	1.09	760	0.85	1.14	787	0.89	1.19	813	0.93	1.24	838	0.97	1.30	861	1.01	1.35	885	1.04	1.40
		1369	2900	670	0.77	1.03	697	0.80	1.07	724	0.83	1.11	750	0.87	1.16	777	0.90	1.21	803	0.95	1.27	828	0.98	1.32	852	1.03	1.38	876	1.07	1.44	898	1.11	1.49
		1416	3000	691	0.81	1.09	717	0.85	1.14	743	0.88	1.18	769	0.93	1.24	794	0.96	1.29	819	1.01	1.35	844	1.06	1.42	868	1.10	1.47	890	1.14	1.53	913	1.18	1.58
		1463	3100	712	0.87	1.16	737	0.90	1.21	762	0.95	1.27	787	0.98	1.32	812	1.04	1.39	836	1.08	1.45	860	1.13	1.51	883	1.17	1.57	906	1.22	1.63	928	1.25	1.68
		1510	3200	732	0.93	1.24	756	0.97	1.30	781	1.01	1.36	805	1.06	1.42	829	1.10	1.48	853	1.16	1.55	876	1.20	1.61	899	1.25	1.67	921	1.29	1.73	943	1.33	1.78
		1557	3300	752	0.99	1.33	776	1.04	1.39	799	1.09	1.46	823	1.13	1.52	847	1.19	1.59	870	1.23	1.65	893	1.28	1.71	916	1.32	1.77	937	1.37	1.83	959	1.40	1.88
		1604	3400	772	1.07	1.43	795	1.12	1.50	818	1.16	1.56	842	1.22	1.63	865	1.26	1.69	888	1.31	1.76	910	1.36	1.82	932	1.40	1.88	953	1.44	1.93	974	1.48	1.99
		1652	3500	792	1.15	1.54	815	1.20	1.61	838	1.25	1.67	861	1.30	1.74	883	1.34	1.80	906	1.40	1.87	928	1.44	1.93	949	1.48	1.98	970	1.52	2.04	990	1.57	2.10
		1699	3600	812	1.23	1.65	834	1.28	1.72	857	1.34	1.79	880	1.38	1.85	902	1.43	1.92	924	1.48	1.98	945	1.52	2.04	966	1.57	2.10	986	1.61	2.16	1005	1.66	2.22
Air Volume		External Static - Pa (in. w.g.)																															
		275 (1.10)			300 (1.20)			325 (1.30)			350 (1.40)			375 (1.50)			400 (1.60)			425 (1.70)			450 (1.80)			475 (1.90)			500 (2.00)				
		Rev/ min	kW BHP	CFM	Rev/ min	kW BHP	CFM	Rev/ min	kW BHP	CFM	Rev/ min	kW BHP	CFM	Rev/ min	kW BHP	CFM	Rev/ min	kW BHP	CFM	Rev/ min	kW BHP	CFM	Rev/ min	kW BHP	CFM	Rev/ min	kW BHP	CFM	Rev/ min	kW BHP	CFM		
		1133	2400	861	0.87	1.16	886	0.90	1.21	911	0.94	1.26	937	0.97	1.30	963	1.01	1.35	988	1.05	1.41	1012	1.10	1.47	1034	1.14	1.53	1055	1.19	1.59	1076	1.23	1.65
		1180	2500	872	0.92	1.23	896	0.95	1.27	921	0.98	1.32	947	1.02	1.37	972	1.07	1.43	997	1.10	1.48	1019	1.16	1.55	1041	1.20	1.61	1061	1.25	1.68	1081	1.30	1.74
		1227	2600	883	0.97	1.30	908	1.01	1.35	933	1.04	1.40	958	1.08	1.45	982	1.12	1.50	1006	1.17	1.57	1027	1.22	1.63	1048	1.27	1.70	1068	1.32	1.77	1087	1.37	1.83
		1274	2700	895	1.02	1.37	920	1.06	1.42	944	1.10	1.47	969	1.14	1.53	992	1.19	1.59	1015	1.23	1.65	1036	1.28	1.72	1056	1.34	1.79	1075	1.39	1.86	1094	1.43	1.92
		1321	2800	908	1.08	1.45	932	1.12	1.50	956	1.16	1.56	980	1.21	1.62	1003	1.25	1.68	1025	1.31	1.75	1045	1.36	1.82	1064	1.41	1.89	1083	1.46	1.96	1102	1.51	2.02
		1369	2900	922	1.15	1.54	945	1.19	1.59	969	1.23	1.65	992	1.28	1.71	1014	1.33	1.78	1035	1.38	1.85	1055	1.43	1.92	1074	1.49	2.00	1092	1.54	2.07	1111	1.59	2.13
		1416	3000	936	1.22	1.63	959	1.25	1.68	982	1.30	1.74	1004	1.35	1.81	1026	1.40	1.88	1046	1.46	1.96	1065	1.51	2.03	1084	1.57	2.11	1102	1.63	2.18	1120	1.68	2.25
		1463	3100	950	1.29	1.73	973	1.33	1.78	995	1.38	1.85	1017	1.42	1.91	1037	1.48	1.99	1057	1.54	2.07	1076	1.60	2.15	1094	1.66	2.23	1112	1.72	2.31	1130	1.78	2.38
		1510	3200	965	1.37	1.83	987	1.41	1.89	1008	1.45	1.95	1029	1.51	2.03	1049	1.57	2.11	1068	1.63	2.19	1087	1.70	2.28	1105	1.76	2.36	1123	1.82	2.44	1141	1.87	2.51
		1557	3300	980	1.45	1.94	1001	1.49	2.00	1022	1.54	2.07	1042	1.60	2.15	1061	1.66	2.23	1080	1.73	2.32	1098	1.80	2.41	1116	1.87	2.50	1134	1.92	2.58	1152	1.98	2.65
		1604	3400	995	1.53	2.05	1015	1.58	2.12	1035	1.63	2.19	1054	1.70	2.28	1073	1.77	2.37	1092	1.84	2.46	1110	1.90	2.55	1128	1.97	2.64	1145	2.03	2.72	1163	2.08	2.79
		1652	3500	1010	1.62	2.17	1029	1.67	2.24	1048	1.73	2.32	1067	1.80	2.41	1086	1.87	2.51	1104	1.94	2.60	1122	2.01	2.70	1139	2.07	2.78	1157	2.13	2.86	1174	2.19	2.93
		1699	3600	1024	1.72	2.30	1043	1.78	2.38	1062	1.84	2.46	1080	1.90	2.55	1098	1.98	2.65	1116	2.05	2.75	1133	2.12	2.84	1151	2.19	2.93	1168	2.25	3.01	1186	2.30	3.08

## BLOWER DATA

### BELT DRIVE KIT SPECIFICATIONS - 036-074S

Model No.	Motor kW (HP)		No. of Speeds	Drive Kits and Rev/Min Range							
	Nominal	Max		A01	A02	A03	A04	A05	A06	A07	A08
036	1.5 (2)	1.7 (2.3)	1	561 - 842	---	---	---	748 - 1122	---	---	---
048	1.5 (2)	1.7 (2.3)	1	---	621 - 931	---	---	---	893 - 1191	---	---
060	1.5 (2)	1.7 (2.3)	1	---	---	694 - 1042	---	---	---	1010 - 1290	---
074S	1.2 (1.7)	1.4 (1.9)	2	---	---	---	807 - 1117	---	---	---	994 - 1326

NOTE – Using total air volume and system static pressure requirements determine from blower performance tables rev/min and motor kW required. Maximum usable kW of motors furnished are shown. If motors of comparable kW are used, be sure to keep within the service factor limitations outlined on the motor nameplate.

### BELT DRIVE KIT SPECIFICATIONS - 072H/074H/090S4B/090S4T

Model No.	Motor kW (HP)		No. of Speeds	Drive Kits and Rev/Min Range			
	Nominal	Max		AA02	AA03	AA04	AA05
072H	1.5 (2)	1.7 (2.3)	1	527 - 729	665 - 921	768 - 1023	---
074H, 090S4T	1.2 (1.7)	1.4 (1.9)	2	527 - 729	665 - 921	768 - 1023	---
090S4B	1.5 (2)	1.7 (2.3)	1	527 - 729	665 - 921	768 - 1023	---
	2.2 (3)	2.57 (3.45)	1	---	---	---	921 - 1177

NOTE – Using total air volume and system static pressure requirements determine from blower performance tables rev/min and motor kW required. Maximum usable kW of motors furnished are shown. If motors of comparable kW are used, be sure to keep within the service factor limitations outlined on the motor nameplate.



## BLOWER DATA

### OPTIONS / ACCESSORIES AIR RESISTANCE FOR 036-074 MODELS

Air Volume		Wet Indoor Coil						Economizer	
		036-048		060		072/074			
L/s	cfm	Pa	in. w.g.	Pa	in. w.g.	Pa	in. w.g.	Pa	in. w.g.
375	800	2	0.01	2	0.01	2	0.01	10	0.04
470	1000	5	0.02	5	0.02	2	0.01	10	0.04
565	1200	7	0.03	7	0.04	5	0.02	10	0.04
660	1400	10	0.04	12	0.05	7	0.03	10	0.04
755	1600	12	0.05	15	0.06	7	0.04	10	0.04
850	1800	15	0.06	17	0.07	12	0.05	12	0.05
945	2000	20	0.08	22	0.09	15	0.06	12	0.05
1040	2200	22	0.09	25	0.10	17	0.07	12	0.05
1130	2400	25	0.10	30	0.12	20	0.08	12	0.05
1225	2600	27	0.11	30	0.13	22	0.09	15	0.06
1320	2800	30	0.13	37	0.15	25	0.10	15	0.06
1415	3000	35	0.14	40	0.16	30	0.12	15	0.06

Air Volume		Gas Heat				Filters	
		Medium Input		High Input		MERV 8	
L/s	cfm	Pa	in. w.g.	Pa	in. w.g.	Pa	in. w.g.
375	800	5	0.02	5	0.02	10	0.04
470	1000	5	0.02	5	0.02	10	0.04
565	1200	5	0.02	5	0.02	10	0.04
660	1400	5	0.02	7	0.03	10	0.04
755	1600	7	0.03	12	0.05	10	0.04
850	1800	7	0.03	12	0.05	12	0.05
945	2000	10	0.04	15	0.06	12	0.05
1040	2200	10	0.04	17	0.07	12	0.05
1130	2400	12	0.05	20	0.08	12	0.05
1225	2600	12	0.05	22	0.09	12	0.05
1320	2800	15	0.06	25	0.10	12	0.05
1415	3000	17	0.07	27	0.11	12	0.05

### OPTIONS / ACCESSORIES AIR RESISTANCE FOR 090 MODELS

Air Volume		Wet Indoor Coil		Economizer		Gas Heat - High Input		Filters			
								MERV 8		MERV 13	
L/s	cfm	Pa	in. w.g.	Pa	in. w.g.	Pa	in. w.g.	Pa	in. w.g.	Pa	in. w.g.
1130	2400	20	0.08	12	0.05	7	0.03	12	0.05	20	0.08
1225	2600	22	0.09	15	0.06	10	0.04	12	0.05	20	0.08
1320	2800	25	0.10	15	0.06	10	0.04	12	0.05	20	0.08
1415	3000	30	0.12	15	0.06	10	0.04	12	0.05	20	0.08
1510	3200	30	0.13	15	0.06	10	0.04	15	0.06	22	0.09
1605	3400	35	0.14	15	0.06	12	0.05	15	0.06	22	0.09
1700	3600	37	0.15	15	0.06	12	0.05	15	0.06	25	0.10

### POWER EXHAUST FAN PERFORMANCE

Return Air System Static Pressure		Air Volume Exhausted	
Pa	in. w.g.	L/s	cfm
0	0.00	787	1665
12	0.05	783	1660
25	0.10	757	1605
37	0.15	712	1510
50	0.20	654	1385
62	0.25	593	1255
75	0.30	531	1125
87	0.35	476	1010

## BLOWER DATA

### CEILING DIFFUSERS AIR RESISTANCE

Air Volume		RTD9-65S Step-Down Diffuser						FD9-65S Flush Diffuser		RTD11-95S Step-Down Diffuser						FD11-95S Flush Diffuser	
		2 Ends Open		1 Side & 2 Ends Open		All Ends & Sides Open				2 Ends Open		1 Side & 2 Ends Open		All Ends & Sides Open			
L/s	cfm	Pa	in. w.g.	Pa	in. w.g.	Pa	in. w.g.	Pa	in. w.g.	Pa	in. w.g.	Pa	in. w.g.	Pa	in. w.g.	Pa	in. w.g.
375	800	37	0.15	32	0.13	27	0.11	27	0.11	---	---	---	---	---	---	---	---
470	1000	47	0.19	40	0.16	35	0.14	35	0.14	---	---	---	---	---	---	---	---
565	1200	62	0.25	50	0.20	42	0.17	42	0.17	---	---	---	---	---	---	---	---
660	1400	82	0.33	65	0.26	50	0.20	50	0.20	---	---	---	---	---	---	---	---
755	1600	107	0.43	80	0.32	50	0.20	50	0.24	---	---	---	---	---	---	---	---
850	1800	139	0.56	99	0.40	75	0.30	75	0.30	32	0.13	27	0.11	22	0.09	22	0.09
945	2000	182	0.73	124	0.50	90	0.36	90	0.36	37	0.15	32	0.13	27	0.11	25	0.10
1040	2200	236	0.95	157	0.63	109	0.44	109	0.44	45	0.18	37	0.15	30	0.12	30	0.12
1130	2400	---	---	---	---	---	---	---	---	52	0.21	45	0.18	37	0.15	35	0.14
1225	2600	---	---	---	---	---	---	---	---	60	0.24	52	0.21	45	0.18	42	0.17
1320	2800	---	---	---	---	---	---	---	---	67	0.27	60	0.24	52	0.21	50	0.20
1415	3000	---	---	---	---	---	---	---	---	80	0.32	72	0.29	62	0.25	62	0.25
1510	3200	---	---	---	---	---	---	---	---	102	0.41	92	0.37	80	0.32	77	0.31
1605	3400	---	---	---	---	---	---	---	---	124	0.50	112	0.45	97	0.39	92	0.37
1700	3600	---	---	---	---	---	---	---	---	152	0.61	134	0.54	119	0.48	109	0.44

### CEILING DIFFUSER AIR THROW DATA

Air Volume		<sup>1</sup> Effective Throw									
Model No.		RTD9-65S		FD9-65S		Model No.		RTD11-95S		FD11-95S	
L/s	cfm	m	ft.	m	ft.	L/s	cfm	m	ft.	m	ft.
375	800	3 - 5	10 - 17	4 - 5	14 - 18	1225	2600	7 - 9	24 - 29	6 - 7	19 - 24
470	1000	3 - 5	10 - 17	5 - 6	15 - 20	1320	2800	8 - 9	25 - 30	6 - 9	20 - 28
565	1200	3 - 5	11 - 18	5 - 7	16 - 22	1415	3000	8 - 10	27 - 33	6 - 9	21 - 29
660	1400	4 - 6	12 - 19	5 - 7	17 - 24	1510	3200	9 - 11	28 - 35	7 - 9	22 - 29
755	1600	4 - 6	12 - 20	5 - 8	18 - 25	1605	3400	9 - 11	30 - 37	7 - 9	22 - 30
850	1800	4 - 6	13 - 21	6 - 9	20 - 28	1700	3600	8 - 10	25 - 33	7 - 8	22 - 24
945	2000	4 - 7	14 - 23	6 - 9	21 - 29						
1040	2200	5 - 8	16 - 25	7 - 9	22 - 30						

<sup>1</sup> Effective throw based on terminal velocities of 23 m per minute ( 75 ft. per minute).

## ELECTRICAL DATA

Model No.		KGB036S4	KGB048S4	KGB060S4	KGB072H4
<sup>1</sup> Voltage - 50hz with Neutral (3 Ph)		380/420V	380/420V	380/420V	380/420V
Compressor	Rated Load Amps	4	5.5	8	9.7
	Locked Rotor Amps	31	37	59	64
Outdoor Fan Motor	Full Load Amps	1.1	1.1	1.8	1.3
Power Exhaust (1) 0.25 kW	Full Load Amps	1.3	1.3	1.3	1.3
Indoor Blower Motor	kW	1.5	1.5	1.5	1.5
	Full Load Amps	3.6	3.6	3.6	3.6
<sup>2</sup> Maximum Overcurrent Protection	Unit Only	15	15	20	25
	With (1) 0.25 kW Power Exhaust	15	15	20	25
<sup>3</sup> Minimum Circuit Ampacity	Unit Only	10	12	15	18
	With (1) 0.25 kW Power Exhaust	11	13	17	19

<sup>1</sup> Extremes of operating range are plus and minus 10% of line voltage.

<sup>2</sup> Heating, Air Conditioning, Refrigeration type breaker or fuse.

<sup>3</sup> Refer to local electrical code to determine wire, fuse and disconnect size requirements.

## ELECTRICAL DATA

Model No.		KGB074H4T	KGB074S4B	KGB074S4T	KGB090S4T	KGB090S4B	
<sup>1</sup> Voltage - 50hz with Neutral (3 Ph)		380/420V	380/420V	380/420V	380/420V	380/420V	
Compressor	Rated Load Amps	8.5	8.5	8.5	12	12	
	Locked Rotor Amps	66.1	66.1	66.1	94	94	
Outdoor Fan Motor	Full Load Amps	1.3	1.3	1.3	1.5	1.5	
Power Exhaust (1) 0.25 kW	Full Load Amps	1.3	1.3	1.3	1.3	1.3	
Indoor Blower Motor	kW	1.2	1.5	1.2	1.2	1.5	2.2
	Full Load Amps	2.6	3.6	2.6	2.6	3.6	5.3
<sup>2</sup> Maximum Overcurrent Protection	Unit Only	20	20	20	30	30	30
	With (1) 0.25 kW Power Exhaust	20	25	20	30	30	35
<sup>3</sup> Minimum Circuit Ampacity	Unit Only	15	16	15	20	21	22
	With (1) 0.25 kW Power Exhaust	16	17	16	21	22	24

<sup>1</sup> Extremes of operating range are plus and minus 10% of line voltage.

<sup>2</sup> Heating, Air Conditioning, Refrigeration type breaker or fuse.

<sup>3</sup> Refer to local electrical code to determine wire, fuse and disconnect size requirements.

## UNIT CLEARANCES

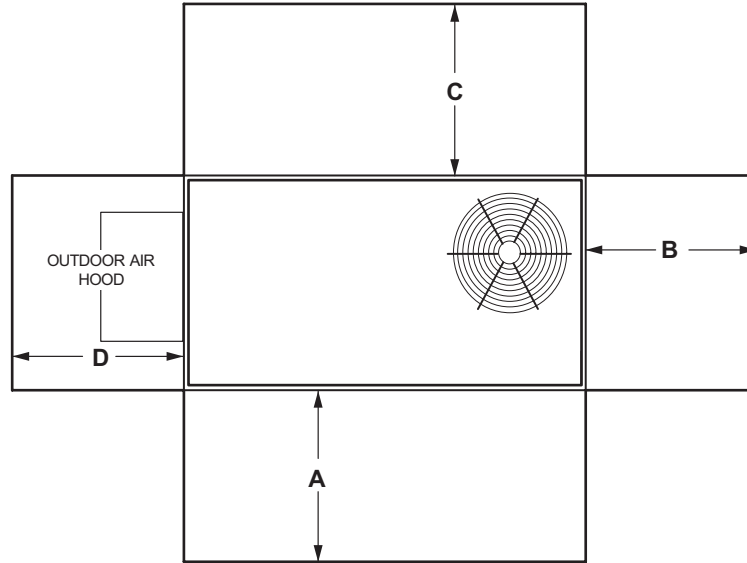

<sup>1</sup> Unit Clearance	A		B		C		D		Top Clearance
	mm	in.	mm	in.	mm	in.	mm	in.	
<b>Service Clearance</b>	914	36	914	36	914	36	914	36	Unobstructed
<b>Clearance to Combustibles</b>	914	36	25	1	25	1	25	1	
<b>Minimum Operation Clearance</b>	914	36	914	36	914	36	914	36	

NOTE - Entire perimeter of unit base requires support when elevated above the mounting surface.

<sup>1</sup> Service Clearance - Required for removal of serviceable parts.

Clearance to Combustibles - Required clearance to combustible material.

Minimum Operation Clearance - Required clearance for proper unit operation.

## OUTDOOR SOUND DATA

Unit Model No.	Octave Band Linear Sound Power Levels dB, re 10 <sup>-12</sup> Watts - Center Frequency - Hz							<sup>1</sup> Sound Rating Number (SRN) (dBA)
	125	250	500	1000	2000	4000	8000	
<b>KGB036 and 048</b>	62	66	70	69	66	60	50	74
<b>KGB060</b>	72	75	78	77	73	68	58	83
<b>KGB072, 074, 090</b>	66	71	74	73	70	65	57	79

Note - The octave sound power data does not include tonal corrections.

<sup>1</sup> Sound Rating Number according to ARI Standard 270-95 (includes pure tone penalty). "SRN" is the overall A-Weighted Sound Power Level, (LWA), dB (100 Hz to 10,000 Hz).

## WEIGHT DATA

Model Number	Outdoor Coil	Net		Shipping		Outdoor Coil	Net		Shipping	
		kg	lbs.	kg	lbs.		kg	lbs.	kg	lbs.
036S Base Unit	Environ™	252	555	270	596	Fin/Tube	267	588	285	629
036S Max Unit	Environ™	318	701	742	337	Fin/Tube	734	333	352	775
048S Base Unit	Environ™	252	555	596	270	Fin/Tube	588	267	285	629
048S Max Unit	Environ™	325	716	757	343	Fin/Tube	749	340	358	790
060S Base Unit	Environ™	294	649	690	313	Fin/Tube	682	309	328	723
060S Max Unit	Environ™	369	813	854	387	Fin/Tube	846	384	402	887
072H Base Unit	Environ™	294	649	690	313	Fin/Tube	n/a	n/a	n/a	n/a
072H Max Unit	Environ™	369	813	854	387	Fin/Tube	n/a	n/a	n/a	n/a
074S Base Unit	Environ™	294	649	690	313	Fin/Tube	682	309	328	723
074S Max Unit	Environ™	369	813	854	387	Fin/Tube	846	384	402	887
074H Base Unit	Environ™	294	649	690	313	---	---	---	---	---
074H Max Unit	Environ™	369	813	854	387	---	---	---	---	---
090S Base Unit	Environ™	355	783	843	382	Fin/Tube	848	385	412	908
090S Max Unit	Environ™	401	883	953	432	Fin/Tube	948	430	462	1018

<sup>1</sup> 074S models only.

NOTE - Max. Unit is the unit with ALL INTERNAL OPTIONS Installed. (Economizer, Standard Static Power Exhaust Fans, Controls, etc.). Does not include accessories EXTERNAL to unit.

## OPTIONS / ACCESSORIES

		Shipping Weights		
		kg	lbs.	
<b>ECONOMIZER / OUTDOOR AIR</b>				
<b>Economizer</b>				
Economizer - Includes Barometric Relief Dampers and Exhaust Hood		59	131	
<b>OUTDOOR AIR</b>				
<b>Outdoor Air Dampers</b>				
Motorized		18	40	
Manual		14	30	
<b>POWER EXHAUST</b>				
Standard Static		16	35	
<b>GAS HEAT</b>				
Medium Heat (adder over standard heat)		4	8	
High Heat (adder over standard heat)		9	19	
<b>ROOF CURBS</b>				
<b>Hybrid Roof Curbs, Downflow</b>				
203 mm height		23	50	
356 mm height		32	70	
457 mm height		36	80	
610 mm height		45	100	
<b>Hybrid Curbs, Full Perimeter, Downflow</b>				
203 mm height		26	57	
356 mm heights		27	60	
457 mm heights		41	91	
457 mm heights		52	114	
<b>Adjustable Pitch Curb, Downflow</b>				
356 mm height		51	113	
<b>CEILING DIFFUSERS</b>				
Step-Down		RTD9-65S	36	80
		RTD11-95S	54	118
Flush		FD9-65S	36	80
		FD11-95S	54	118
Transitions (Supply and Return)		T1TRAN10AN1	10	22
		T1TRAN20N-1	10	21

# DIMENSIONS

# UNIT

Model No.	CORNER WEIGHTS								CENTER OF GRAVITY															
	AA		BB		CC		DD		EE		FF		FF											
	Base	Max.	Base	Max.	Base	Max.	Base	Max.	Base	Max.	Base	Max.	Base	Max.										
	kg	lbs.	kg	lbs.	kg	lbs.	kg	lbs.	kg	lbs.	mm	in.	mm	in.	mm	in.								
<b>036</b>	51	112	64	142	59	130	64	141	76	168	86	190	66	145	104	228	1003	39-1/2	1143	45	521	20-1/2	508	20
<b>048</b>	51	112	66	145	59	130	65	144	76	168	88	194	66	145	106	233	1003	39-1/2	1143	45	521	20-1/2	508	20
<b>060</b>	59	130	74	162	67	147	76	167	90	198	103	226	79	175	117	257	1016	40	1118	44	508	20	508	20
<b>072</b>	59	130	74	162	67	147	76	167	90	198	103	226	79	175	117	257	1016	40	1118	44	508	20	508	20
<b>074</b>	59	130	74	162	67	147	76	167	90	198	103	226	79	175	117	257	1016	40	1118	44	508	20	508	20
<b>090</b>	76	168	88	195	83	183	96	212	103	227	119	263	95	203	109	241	1194	47	1194	47	533	21	533	21

Base Unit - The unit with NO INTERNAL OPTIONS.

Max. Unit - The unit with ALL INTERNAL OPTIONS Installed. (Economizer, Standard Static Power Exhaust Fans, Controls, etc.). Does not include accessories external to unit or high static power exhaust.

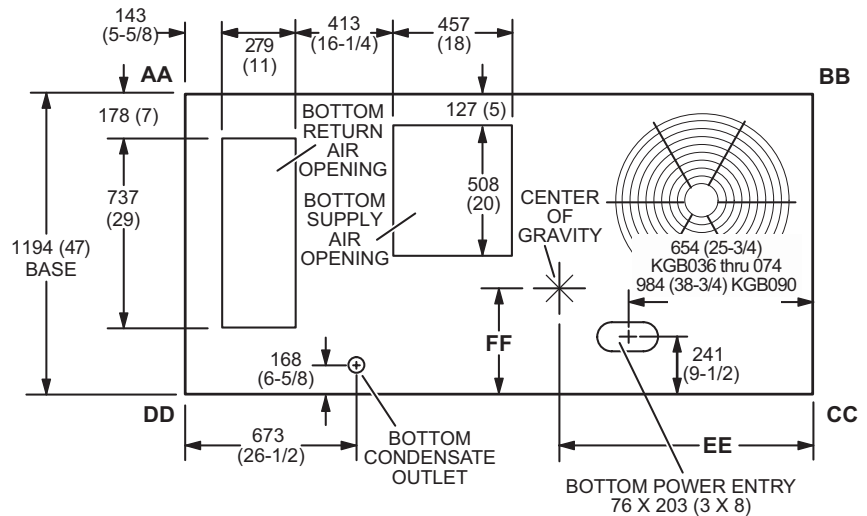

**TOP VIEW (Base)**

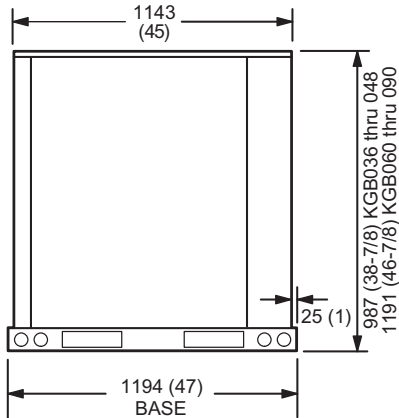

**END VIEW**

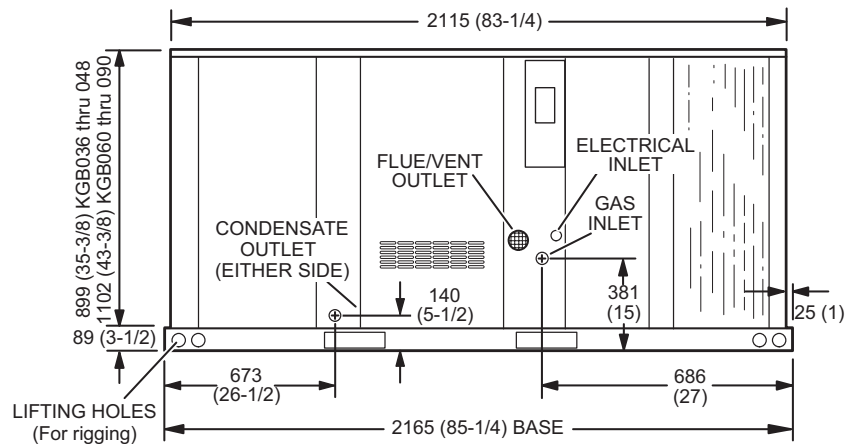

**SIDE VIEW**

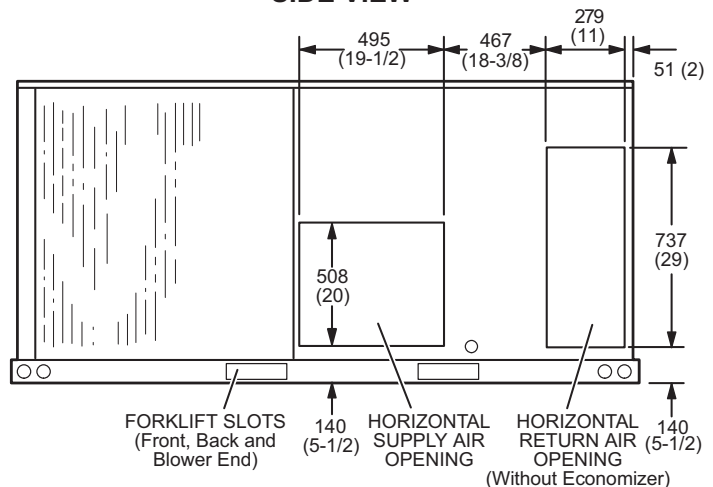

**BACK VIEW**

**COMBINATION OUTDOOR AIR HOOD DETAIL FOR OPTIONAL ECONOMIZER AND BAROMETRIC RELIEF DAMPERS  
(Furnished With Economizer for Downflow Applications)**

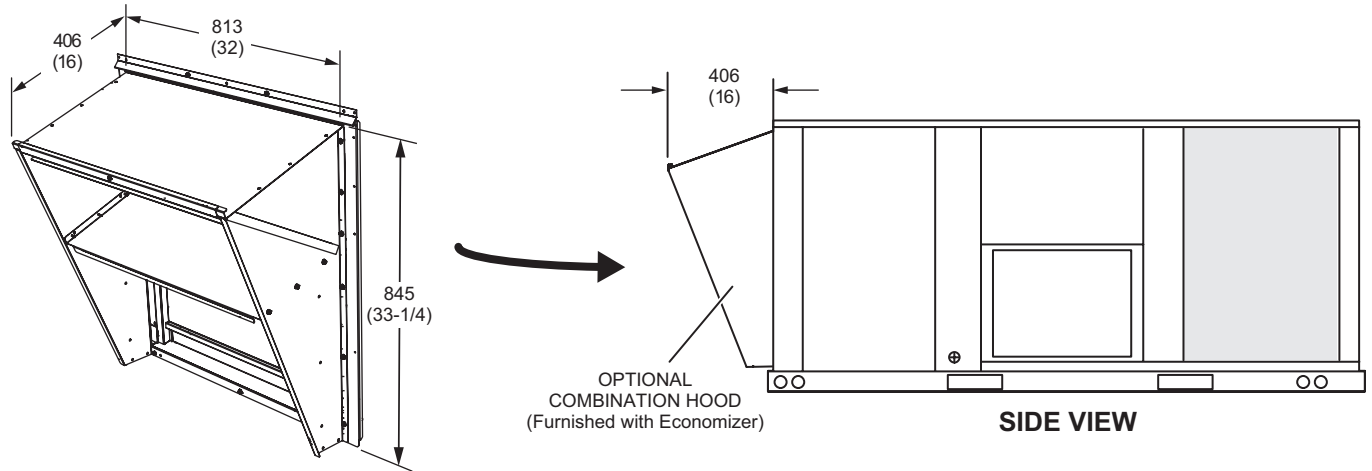

**OUTDOOR AIR DAMPER HOOD DETAIL (Downflow or Horizontal Applications)**

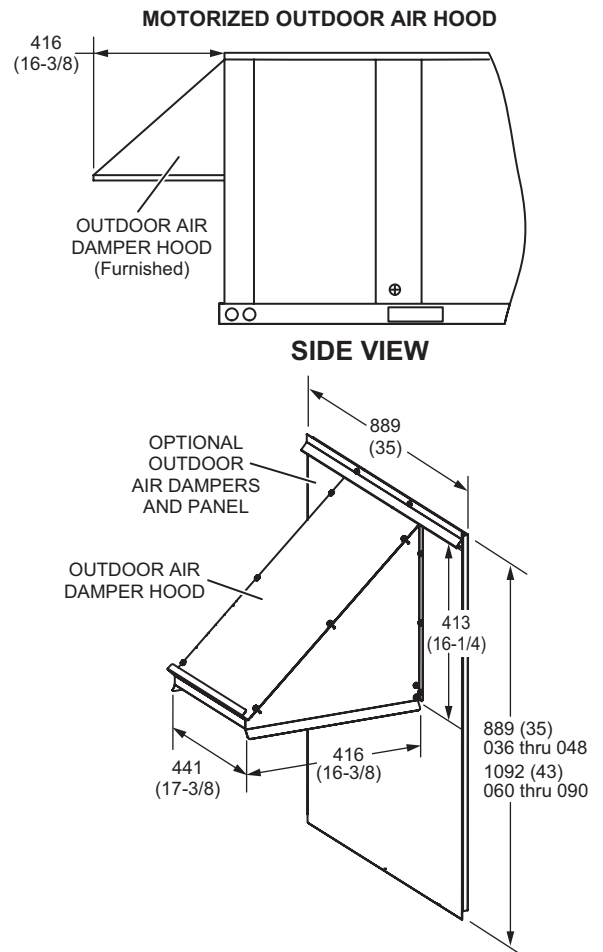
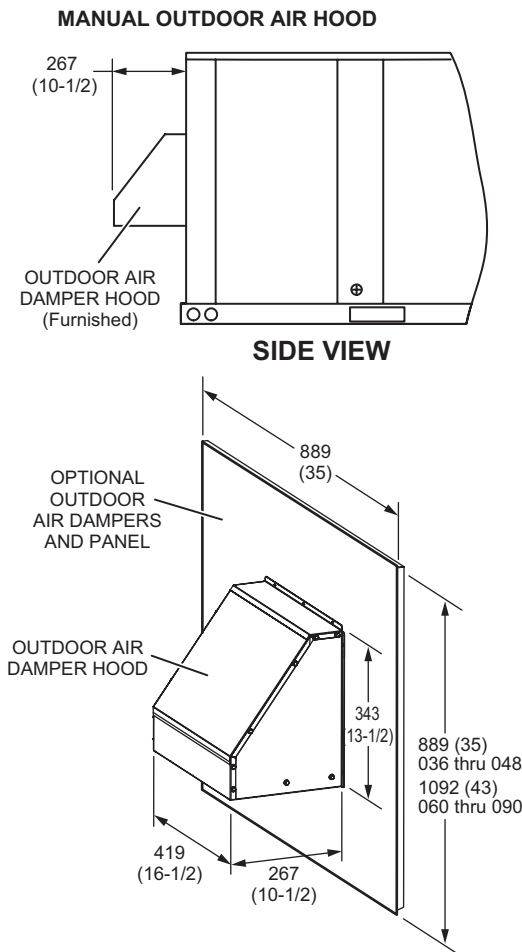



**OUTDOOR AIR HOOD DETAIL WITH OPTIONAL ECONOMIZER AND  
OPTIONAL BAROMETRIC RELIEF DAMPERS WITH HOOD  
(Horizontal Application)**

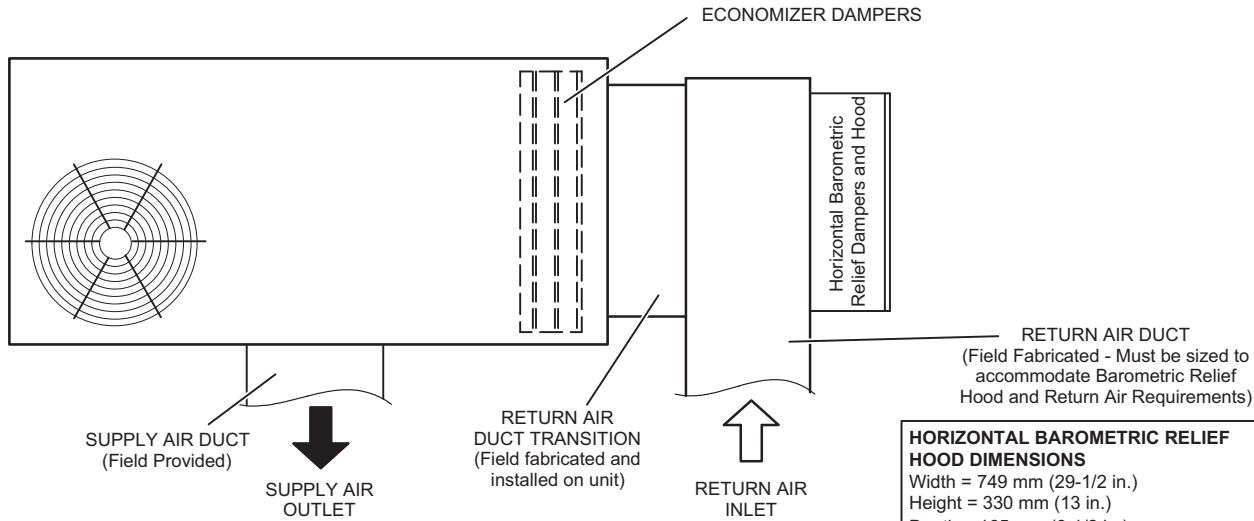

**TOP VIEW**

**HORIZONTAL BAROMETRIC RELIEF HOOD DIMENSIONS**  
 Width = 749 mm (29-1/2 in.)  
 Height = 330 mm (13 in.)  
 Depth = 165 mm (6-1/2 in.)

**NOTE -** Horizontal applications with Economizer require **Horizontal Economizer Conversion Kit.** See Options/Accessories table.

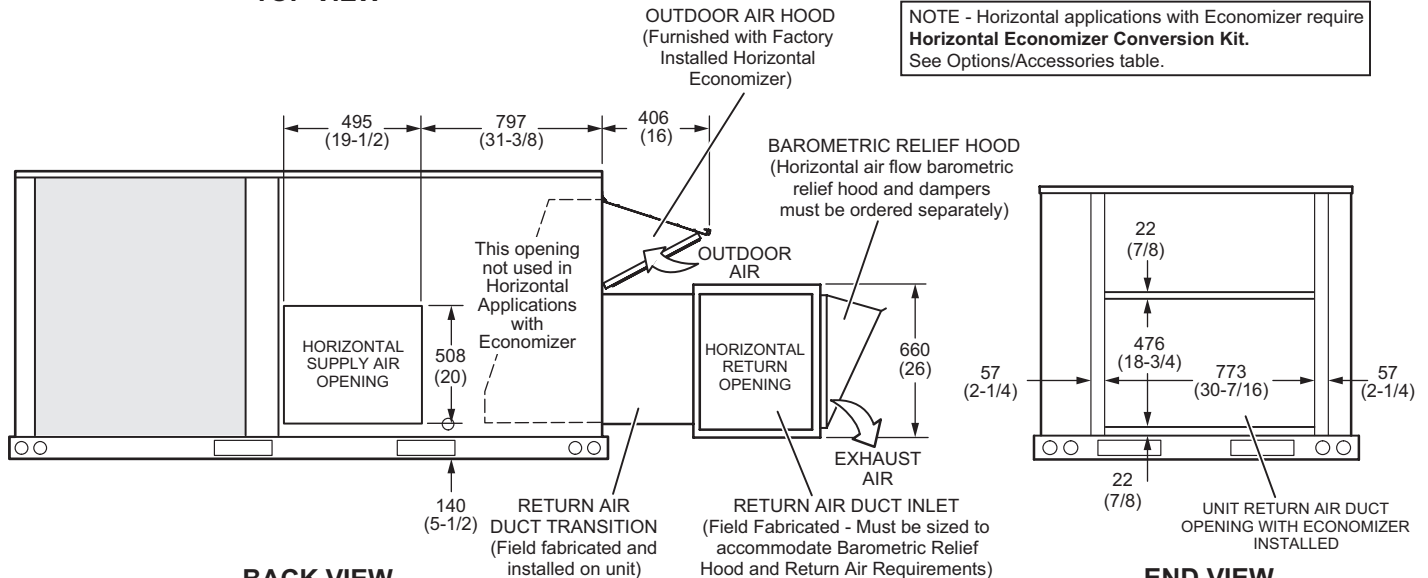

**BACK VIEW**

**END VIEW**

**NOTE -** Return Air Duct and Transition must be supported

**HYBRID ROOF CURBS - DOUBLE DUCT OPENING - STANDARD AND FULL PERIMETER**

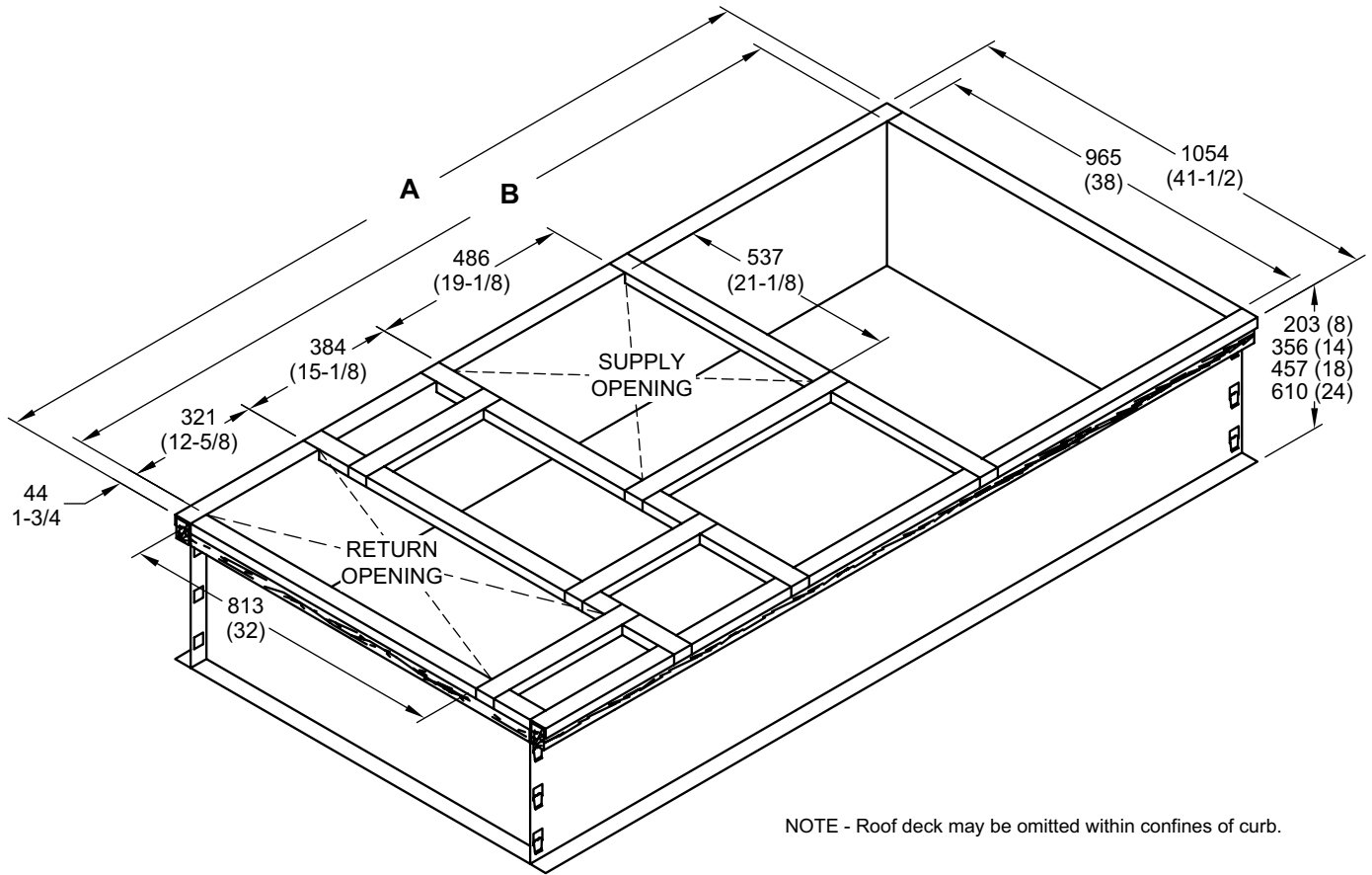

NOTE - Roof deck may be omitted within confines of curb.

**TYPICAL FLASHING DETAIL FOR ROOF CURB**

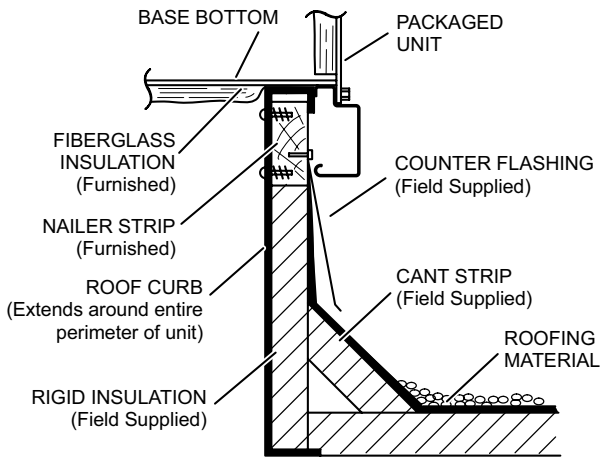

**DETAIL ROOF CURB**

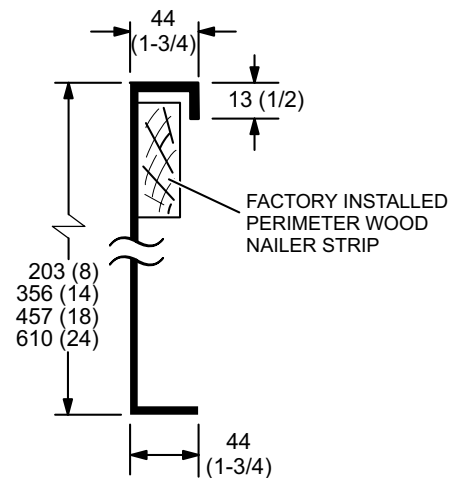

Model No.	A		B	
	mm	in.	mm	in.
Standard - 036, 048, 060, 072, 074, <sup>1</sup> 090	2026	79-3/4	1937	76-1/4
Full Perimeter - 090	2356	92-3/4	2267	89-1/4

<sup>1</sup> 090 models can be used on smaller 2026 mm (79-3/4 in.) roof curbs (not full perimeter) with 400 mm (15-3/4 in.) overhang at condenser end of unit. See dimension drawing on page 50.

**ADJUSTABLE PITCH CURBS - DOUBLE DUCT OPENING**

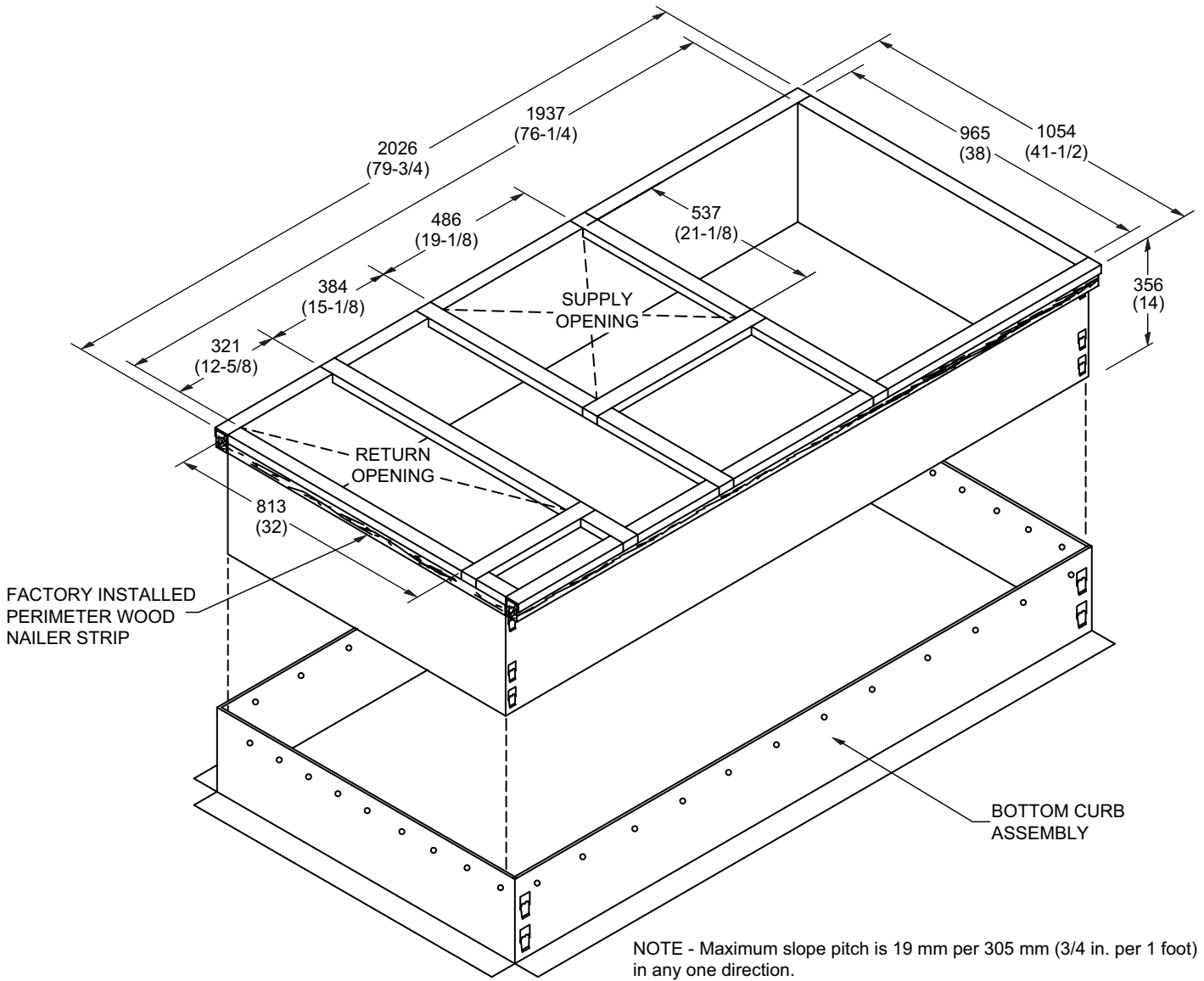

**TYPICAL FLASHING DETAIL FOR ROOF CURB**

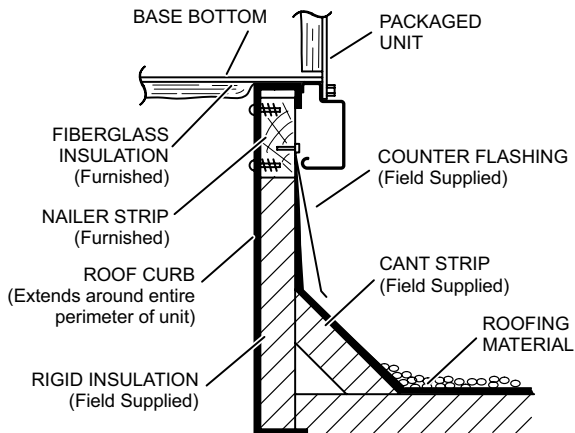

**DETAIL ROOF CURB**

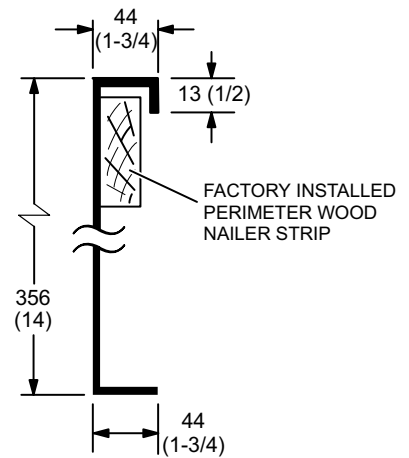

**090 MODELS - SHOWING OVERHANG ON SMALLER 2026 MM LENGTH ROOF CURBS  
(Not Full Perimeter)**

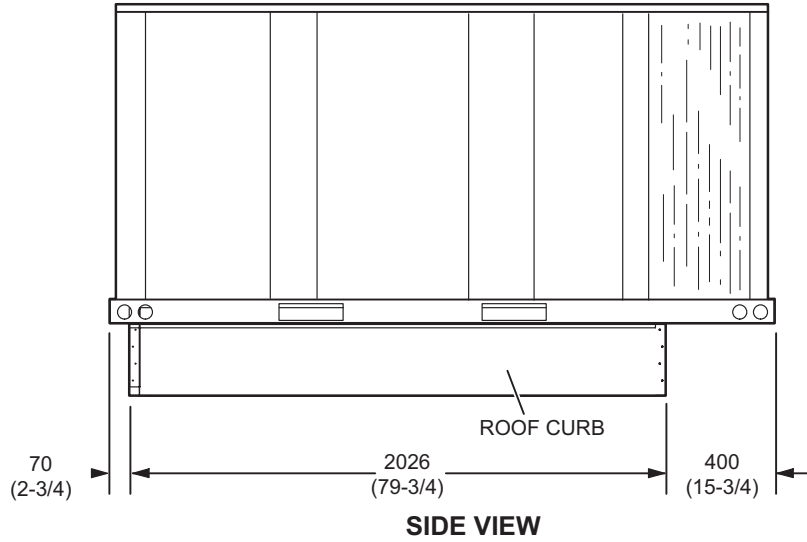

**TRANSITIONS**

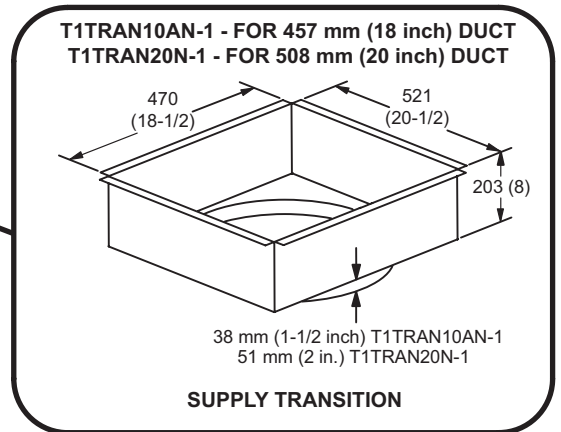
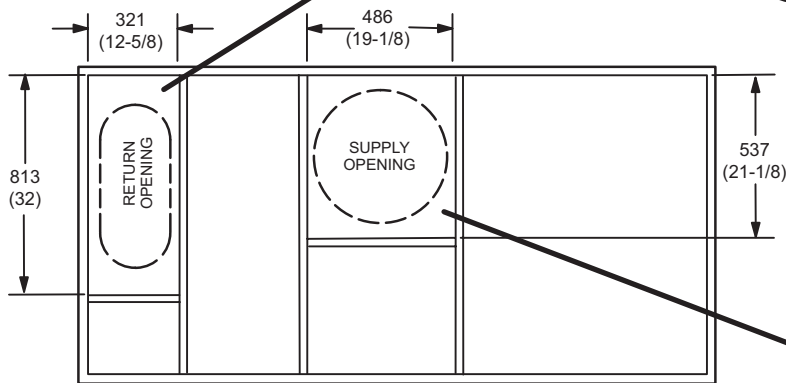
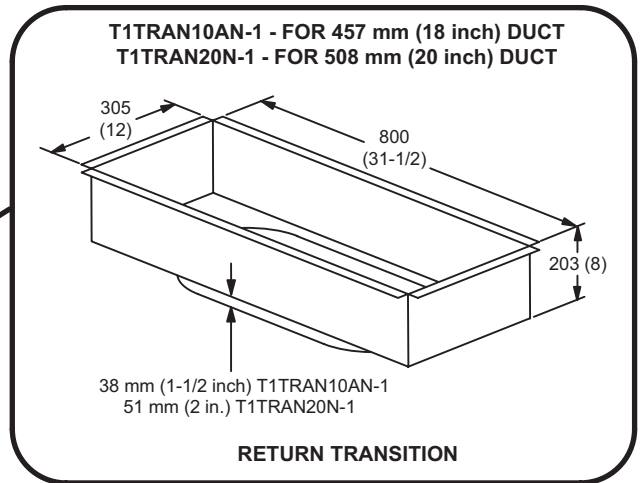

**COMBINATION CEILING SUPPLY AND RETURN DIFFUSERS**

**STEP-DOWN CEILING DIFFUSER**

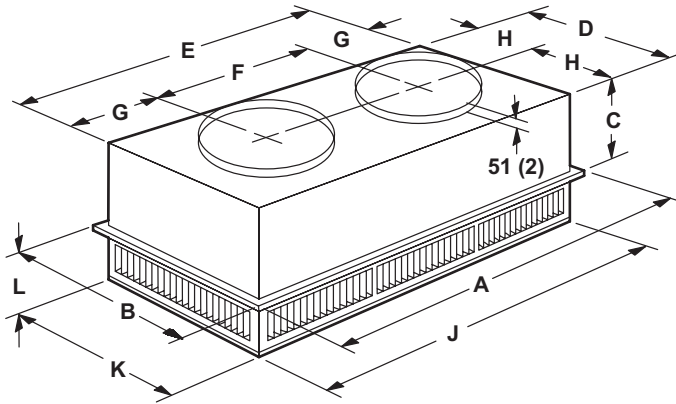

**FLUSH CEILING DIFFUSER**

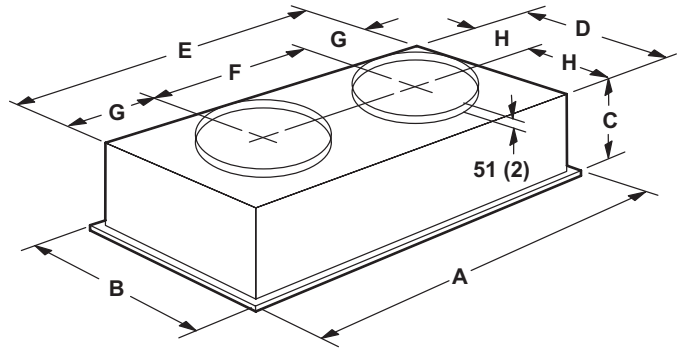

Model Number		RTD9-65S	RTD11-95S
A	mm	1159	1159
	in.	47-5/8	47-5/8
B	mm	600	752
	in.	23-5/8	29-5/8
C	mm	289	365
	in.	11-3/8	14-3/8
D	mm	546	699
	in.	21-1/2	27-1/2
E	mm	1156	1158
	in.	45-1/2	45-1/2
F	mm	572	572
	in.	22-1/2	22-1/2
G	mm	292	292
	in.	11-1/2	11-1/2
H	mm	273	349
	in.	10-3/4	13-3/4
J	mm	1156	1156
	in.	45-1/2	45-1/2
K	mm	546	699
	in.	21-1/2	27-1/2
L	mm	181	206
	in.	7-1/8	8-1/8
Duct Size	mm	457 round	508 round
	in.	18 round	20 round

Model Number		FD9-65S	FD11-95S
A	mm	1159	1159
	in.	47-5/8	47-5/8
B	mm	600	752
	in.	23-5/8	29-5/8
C	mm	343	422
	in.	13-1/2	16-5/8
D	mm	533	686
	in.	21	27
E	mm	1143	1143
	in.	45	45
F	mm	572	572
	in.	22-1/2	22-1/2
G	mm	286	286
	in.	11-1/4	11-1/4
H	mm	267	343
	in.	10-1/2	13-1/2
Duct Size	mm	457 round	508 round
	in.	18 round	20 round









## REVISIONS

Sections	Description of Change
Options/Accessories	<b>Catalog numbers revised for:</b> Cold Weather Kits Disconnects Economizers Gravity Exhaust Dampers LPG Kits Power Exhaust Single Enthalpy Smoke Detectors



Visit us at [www.lennox.com](http://www.lennox.com)

For the latest technical information, [www.lennoxcommercial.com](http://www.lennoxcommercial.com)

Contact us at 1-800-4-LENNOX

NOTE - Due to Lennox' ongoing commitment to quality, Specifications, Ratings and Dimensions subject to change without notice and without incurring liability. Improper installation, adjustment, alteration, service or maintenance can cause property damage or personal injury. Installation and service must be performed by a qualified installer and servicing agency.

©2021 Lennox Industries, Inc.