

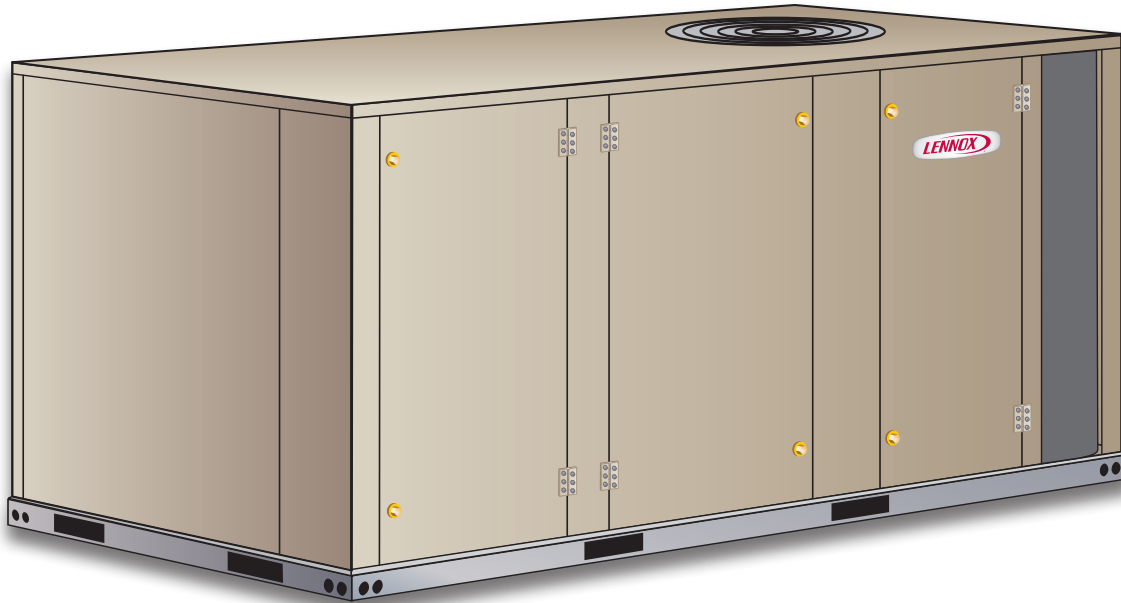

**COMMERCIAL
PRODUCT SPECIFICATIONS**



LANDMARK®
Performance Marked by Flexibility™

10.5 to 21 kW (3 to 6 Tons)
Net Cooling Capacity - 8.8 to 17.3 kW (30 000 to 58 900 Btuh)
Net Heating Capacity - 8.8 to 18.4 kW (30 000 to 63 000 Btuh)
Optional Electric Heat - 5.7 to 23 kW

MODEL NUMBER IDENTIFICATION

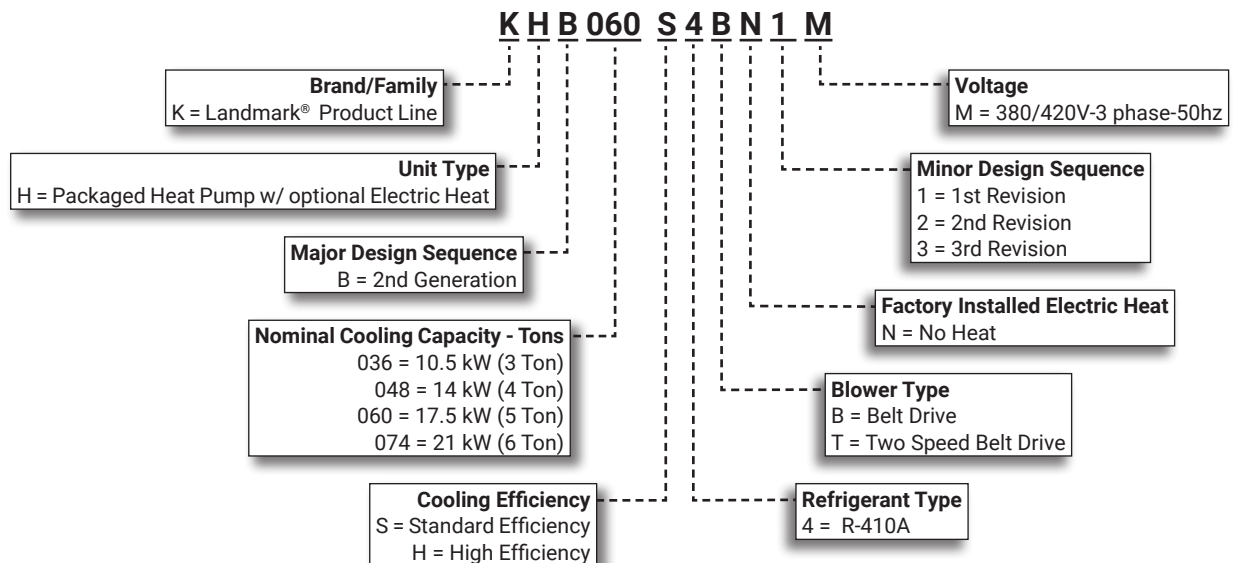

FEATURE HIGHLIGHTS

Landmark® rooftop units from Lennox are the new standard for reliable, efficient rooftop units built for long-lasting performance that can significantly improve indoor environments.

1. Scroll Compressor
2. Check/Thermal Expansion Valve
3. Reversing Valve
4. Coil Construction
5. Outdoor Coil Fan Motor
6. Heavy Gauge Steel Cabinet
7. Power Entry
8. Exterior Panels
9. Insulation
10. Hinged Access Panels (option)
11. Supply Air Blower
12. Unit Control
13. Electric Heat (option)
14. Economizer (option)
15. Power Exhaust Fans (option)

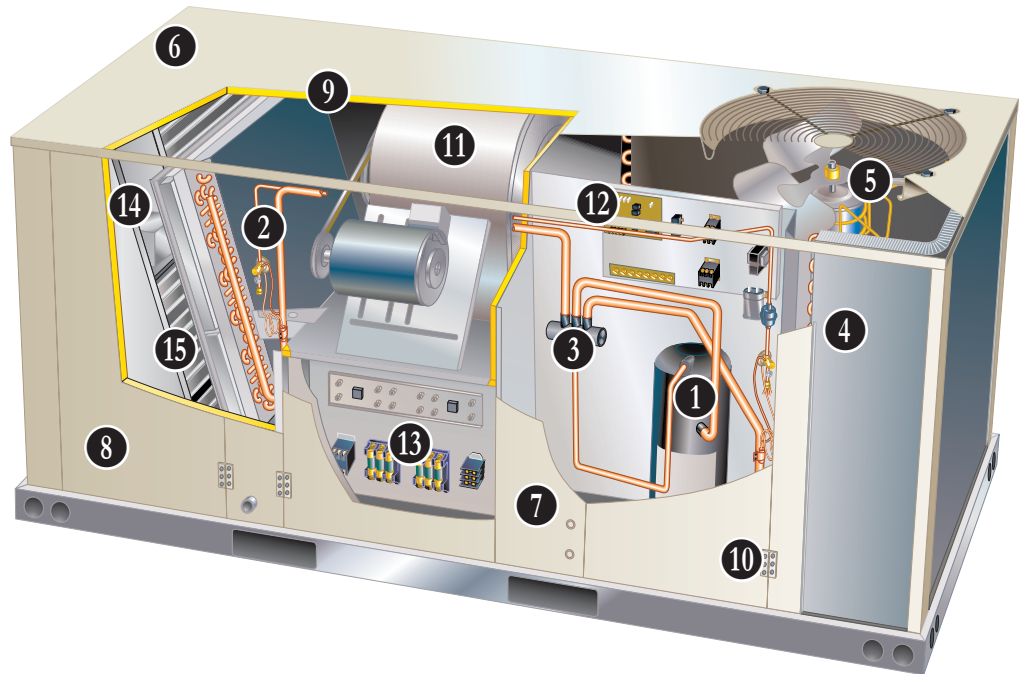

(Unit shown With Optional Electric Heat, Economizer, Power Exhaust and Hinged Access Panels)

CONTENTS

Blower Data	23
Cooling / Heating Ratings	16
Dimensions - Accessories	38
Dimensions - Unit	37
Electrical Data / Electric Heat Data	33
Feature Highlights	2
Features And Benefits	3
Model Number Identification.	1
Optional Conventional Temperature Control Systems	10
Options / Accessories	11
Outdoor Sound Data	35
Specifications	14
Unit Clearances	35
Weight Data	36

PERFORMANCE/QUALITY AND CE MARK OPTION

PERFORMANCE / QUALITY

- Components bonded for grounding to meet safety standards for servicing required by Underwriters Laboratories (UL) and the International Electrotechnical Commission (IEC)
- 10.5 through 17.5 kW models cooling performance is rated at test conditions included in Air-Conditioning, Heating and Refrigeration Institute (AHRI) Standard 210/240-2008 while operating at rated voltage and air volumes
- 21.0 kW models cooling performance is rated at test conditions included in Air-Conditioning, Heating and Refrigeration Institute (AHRI) Standard 340/360-2007 while operating at rated voltage and air volumes
- International Organization for Standardization (ISO) 9001 Registered Manufacturing Quality System

CE MARK OPTION

(Standard Efficiency Models Only)

- The CE mark has been added to our rooftop product line as a configure to order (CTO) option. This optional construction allows units to be sold into countries requiring CE marking for rooftop products
- CE marked units meet the requirements of the Machinery Directive 2006/42/EC
- Low Voltage Directive 73/23/EEC, EMC Directive 89/336/EEC, and Gas Directive 90/396/EEC. Declaration of conformity certificates will be provided for each CE marked unit on demand
- Key features of this over and above standard product features are:
 - Touch-proof electrical components meeting the requirements of EN 60529
 - Branch circuits over 0.5 kW load have overcurrent protection
 - Rotary style/finger safe disconnect switch with locking handle prevents disconnect door from being opened with the power on. Padlock can be applied to lock the disconnect switch in the OFF position
 - The factory wiring has been redesigned for separation of high and low voltage circuits



FEATURES AND BENEFITS

COOLING / HEATING SYSTEM

- Designed to maximize sensible and latent cooling performance at design conditions
- System can operate from -1°C to 52°C without any additional controls

R-410A Refrigerant

- Non-chlorine based
- Ozone-friendly
- Unit pre-charged with refrigerant

1 Single Speed Scroll Compressor (036 through 060 Standard Efficiency Models)

- Scroll compressors for high performance, reliability and quiet operation
- Resiliently mounted on rubber grommets for quiet operation

Two-Stage Compressor (All High Efficiency Models and 074 Standard Efficiency Models)

- Two-stage scroll compressors for increased part load efficiency, high performance, reliability and quiet operation
- Resiliently mounted on rubber grommets for quiet operation

Compressor Crankcase Heater

- Protects against refrigerant migration that can occur during low ambient operation

High Pressure Switch

- Protects the system from high pressure conditions

2 Check/Thermal Expansion Valve

- Ensures optimal performance throughout the application range
- Removable element head

3 Reversing Valves

- 4-way interchange reversing valve effects a rapid change in direction of refrigerant flow resulting in quick changeover from cooling to heating and vice versa

Defrost Control

- Control furnished as standard
- Gives a demand defrost cycle whenever system heating performance falls below optimum levels
- Sensing element on coil determines when defrost cycle is required and when to terminate cycle
- Anti-short cycle (5 minutes) incorporated into the board

Diagnostic LED's furnished as an aid in troubleshooting

Filter/Drier

- High capacity filter/drier protects the system from dirt and moisture

FEATURES AND BENEFITS

COOLING / HEATING SYSTEM (continued)

Freezestat

- Protects the evaporator coil from damaging ice build-up due to conditions such as low/no air flow, or low refrigerant charge

4 Coil Construction

- Copper tube construction
- Enhanced rippled-edge aluminum fins
- Flared shoulder tubing connections
- Silver soldered construction
- Factory leak tested

Indoor Coil

- Cross row circuiting
- Rifled copper tubing optimizes both sensible and latent cooling capacity

Condensate Drain Pan

- Plastic pan, sloped to meet drainage requirements of ASHRAE 62.1
- Side or bottom drain connections
- Reversible to allow connection at back of unit

5 Outdoor Coil Fan Motor

- High efficiency models have a variable speed (ECM) fan motor for energy efficient and quiet operation
- Standard efficiency models have a single speed PSC fan motor
- Thermal overload protected
- Totally enclosed
- Permanently lubricated sleeve bearing (standard efficiency)
- Permanently lubricated ball bearings (high efficiency)
- Shaft up
- Wire basket mount

Outdoor Coil Fan

- Polyvinyl chloride (PVC) coated fan guard furnished

Required Selections

Cooling Capacity

- Specify nominal cooling capacity

Options / Accessories

Field Installed

Condensate Drain Trap

- Available in copper or polyvinyl chloride (PVC)

Drain Pan Overflow Switch

- Monitors condensate level in drain pan, shuts down unit if drain becomes clogged

Low Ambient Kit

- Designed for use in ambient temperatures no lower than -18°C
- Cycles the outdoor fan while allowing compressor operation in the cooling cycle
- Includes field installed pressure switch on the liquid line to determine when to operate the outdoor fan
- This intermittent fan operation allows the system to operate without icing the evaporator coil and losing capacity
- **Standard Efficiency Models** - If the liquid line pressure drops below 1.65 MPa outdoor fan stops until main pressure switch has reset to 3.10 MPa to resume normal cooling operation
- **High Efficiency Models** - If the liquid line pressure drops below 1.65 MPa outdoor fan operates at 25% normal fan speed
- If pressure drops below 1.24 MPa outdoor fan stops until pressure rises to 2.06 MPa, then fan operates at 25% normal fan speed unless main pressure switch has reset to 3.10 MPa to resume normal cooling operation and full fan speed operation

FEATURES AND BENEFITS

CABINET

6 Construction

- Heavy-gauge steel panels
- Two-layer enamel paint finish
- Full perimeter heavy-gauge galvanized steel base rail
- Base rails have rigging holes
- Three sides of the base rail have fork slots
- Raised edges around duct and power entry openings in the bottom of the unit for water protection

Airflow Choice

- Units are shipped in downflow (vertical) configuration
- Can be field converted to horizontal air flow configuration without the need of a kit

7 Power Entry

- Electrical lines can be brought through the unit base or through horizontal access knock-outs

8 Exterior Panels

- Constructed of heavy-gauge, galvanized steel with a two-layer enamel paint finish

9 Insulation

- Fully insulated with non-hygroscopic fiberglass insulation (conditioned areas)
- Unit base is fully insulated
- Base insulation serves as an air seal to the roof curb, eliminating the need to add a seal during installation

Access Panels

- Economizer/Filter section
- Heating/Blower section
- Compressor/Controls section

NOTE - 048/060/074 models include a filler panel for proper cabinet fit for optional accessories (Economizers, Power Exhaust, Outdoor Air Dampers and Barometric Relief Dampers).

Options / Accessories

Factory Installed

Corrosion Protection

- Completely flexible immersed coating
- Electrodeposited dry film process
- AST ElectroFin E-Coat
- Meets Mil Spec MIL-P-53084, ASTM B117 Standard Method Salt Spray Testing
- Indoor Corrosion Protection:
 - Coated coil
 - Painted blower housing
 - Painted base
- Outdoor Corrosion Protection:
 - Coated coil
 - Painted outdoor base

10 Hinged Access Panels

- Economizer/Filter section
- Heating/Blower section
- Compressor/Controls section
- Panel seals and quarter-turn latching handles provide a tight air and water seal

Field Installed

Combination Coil/Hail Guards

- Heavy gauge steel frame
- Painted to match cabinet
- Expanded metal mesh protects outdoor coil

11 BLOWER

A wide selection of supply air blower options are available to meet a variety of air flow requirements

Motor

- Overload protected
- Ball bearings (belt drive)
- Sleeve bearings (direct drive)
- Direct Drive motors are available on 024, 030, 036 and 048 standard efficiency models
- Variable-Speed ECM direct drive motors are available on 024, 036, 048 and 060 high efficiency models
- Single Speed belt drive motors are available on 036, 048 and 060 standard efficiency models in several different sizes to maximize air performance
- Two-Speed belt drive motors (low static/high static) are available on 036, 048 and 060 high efficiency models and 074 standard efficiency model in several different sizes to maximize air performance

Supply Air Blower

- Forward curved blades
- Blower wheel is statically and dynamically balanced
- Belt drive motors have adjustable pulley for speed change

Required Selections

Ordering Information

- Specify drive kit number when base unit is ordered
- Specify motor output and drive kit number when base unit is ordered
- See Drive Kit Specifications Table

FEATURES AND BENEFITS

CONTROLS

12 Unit Control

- All control voltage is provided via a 24V (secondary) transformer with built-in circuit breaker protection
- Up to 2 heat / 2 cool staging with a third party DDC control system or thermostat
- Low voltage terminal block provides screw terminal connections for thermostat or controller wiring
- Night Setback Mode saves energy by closing outdoor air dampers and operating supply fan on thermostat demand only

Options / Accessories

Field Installed

Smoke Detector

- Photoelectric type
- Installed in supply air section, return air section or both sections
- Available with power board and single sensor (supply or return) or power board and two sensors (supply and return)
- Power board located in unit control compartment

Thermostats

- Control system and thermostat options, see page 10

INDOOR AIR QUALITY

Air Filters

- Disposable 51 mm filters furnished as standard

Options / Accessories

Field Installed

Healthy Climate® High Efficiency Air Filters

- Disposable MERV 8 or MERV 13 (Minimum Efficiency Reporting Value based on ASHRAE 52.2) efficiency 2 inch pleated filters

Healthy Climate® UVC Germicidal Lamps

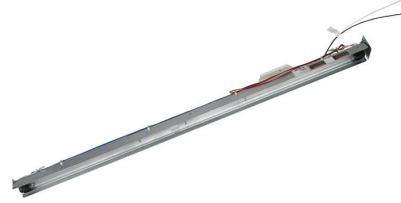

- Germicidal lamps emit ultra-violet (UV-C) energy, which has been proven to be effective in reducing microbes such as viruses, bacteria, yeasts, and molds
- This process either destroys the organism or controls its ability to reproduce
- UV-C energy greatly reduces the growth and proliferation of mold and other bioaerosols (bacteria and viruses) on illuminated surfaces (particularly coil and drain pan)
- Field installed in the blower/evaporator coil section
- Magnetic safety interlock terminates power when access panels are removed
- All necessary hardware for installation is included
- Lamps operate on 220V-1ph power supply

NOTE - Step-down transformer must be field supplied for field installation for 380/420V primary to 220V secondary.

Indoor Air Quality (CO₂) Sensor

- Monitors CO₂ levels
- Reports to the Unit Controller which adjusts economizer dampers as needed

ELECTRICAL

Marked & Color-Coded Wiring

- All electrical wiring is color-coded and marked to identify which components it is connecting

Electrical Plugs

- Positive connection electrical plugs are used to connect common accessories or maintenance parts for easy removal or installation

Unit Sub-Fuse Blocks

- Furnished as standard on all units

Options / Accessories

Field Installed

13 Electric Heat

- Electric Heat is CE marked
- Helix wound nichrome elements
- Individual element limit controls
- Wiring harness
- Unit fuse block

OPTIONS / ACCESSORIES

ECONOMIZER

Factory or Field Installed

14 Economizer (Standard and High Performance Common Features)

- Combination Outdoor Air Hood is furnished
- Factory installed Economizer can be ordered with two exhaust options:
 - Barometric Relief Dampers
 - No Exhaust
- Field installed Economizer includes Barometric Relief Dampers with Combination Hood
- Barometric Relief Dampers allow relief of excess air, dampers prevent blow back and outdoor air infiltration during off cycle, bird screen furnished

NOTE - Barometric Relief Dampers are required when Economizer is factory installed with field installed Power Exhaust Fan option. See Power Exhaust Fan section and Options/Accessories table.

- Occupied/Unoccupied mode with field furnished setback thermostat
- Demand Control Ventilation (DCV) ready using optional CO₂ sensors
- Mixed Air Sensor is furnished for field installation in the rooftop unit

NOTE - Sensor is factory installed when Economizers are factory installed.

- Single sensible sensor is furnished with Economizer and enables economizer operation if the outdoor temperature is less than the setpoint of the control
- Horizontal Barometric Dampers are required for horizontal Economizer applications and must be ordered separately

Standard Economizer Features

Gear-driven action

- Return air and outdoor air dampers
- Plug-in connections to unit
- Neoprene seals
- 24-volt, fully-modulating spring return motor

Standard Economizer Control Module

• The Standard Economizer Control Module can be adjusted to operate based on outdoor air temperatures.

• Economizer Controls:

- **Damper Minimum Position** - Can be set lower than traditional minimum air requirements resulting in cost savings
- **Indoor Air Quality (IAQ) Sensor** - Signals dampers to modulate and maintain 13°C when CO₂ is higher than the CO₂ setpoint
- **Demand Control Ventilation (DCV)** light-emitting diode (LED) - A steady green DCV LED indicates the IAQ reading is higher than setpoint and requires more fresh air



- **Free Cool LED** - A steady green LED indicates outdoor air is suitable for free cooling
- Free Cooling runs when outdoor air temperature is lower than the set temperature on the economizer control

NOTE: The Free Cooling default setting for outdoor air temperature sensor is 13°C.

High Performance Economizer Features

- Gear-driven action
- High torque 24-volt fully-modulating spring return damper motor
- Return air and outdoor air dampers
- Plug-in connections to unit
- Nylon bearings
- Enhanced thermoplastic vulcanizate (TPV) blade edge seals
- Flexible stainless steel jamb seals

High Performance Economizer Control Module

- Module provides inputs and outputs to control economizer based on parameter settings
- Module automatically detects sensors by polling to determine which sensors are installed in system
- Module displays any alarm messages (fault detection and diagnostics) as an aid in troubleshooting
- Non-volatile memory retains parameter settings in case of power failure
- Keypad with four navigation buttons and LCD screen is furnished for setting economizer parameters:
 - Menu Up/Exit (↑) button returns to the main menu
 - Arrow Up (▲) button moves to the previous or next parameter within the selected menu
 - Arrow Down (▼) button moves to the next parameter within the selected menu
 - Select (enter) (↵) button confirms parameter selection



Main Menu Structure:

- **Status** (economizer and system operation status)
- **Setpoints** (settings for various setpoint parameters)
- **System Setup** (settings/information about the system)
- **Advanced Setup** (freeze protection, CO₂ settings, stage 3 delay and additional calibration settings)
- **Checkout** (damper positions)
- **Alarms** (output signal that can be configured for remote alarm monitoring)

NOTE - Refer to Installation Instructions for complete setup information and menu parameters available.

OPTIONS / ACCESSORIES

ECONOMIZER (continued)

Factory or Field Installed

Single Enthalpy Temperature Control

- Outdoor air enthalpy sensor enables Economizer if the outdoor enthalpy is less than the setpoint of the control

Field Installed

Differential Enthalpy Control

- Order two Single Enthalpy Controls
- One is field installed in the return air section, the other in the outdoor air section
- Allows the economizer control board to select between outdoor air or return air, whichever has lower enthalpy

Horizontal Barometric Relief Dampers

- For use when unit is configured for horizontal applications with an economizer
- Allows relief of excess air
- Blade type dampers prevent blow back and outdoor air infiltration during off cycle
- Field installed in return air duct
- Exhaust hood with bird screen furnished

NOTE - Requires Horizontal Economizer Conversion Kit.

Horizontal Economizer Conversion Kit

- Insulated panel covers the bottom return air opening on the unit base to convert downflow Economizer to horizontal airflow

EXHAUST

Field Installed

15 Power Exhaust Fan

- Installs internal to unit for downflow applications only with Economizer option
- Provides exhaust air pressure relief
- Interlocked to run when supply air blower is operating, fan runs when outdoor air dampers are 50% open (adjustable)
- Motor is overload protected
- Fan is 406 mm diameter
- 4 fan blades
- 0.25 kW motor

NOTE - If Power Exhaust is field installed with a factory installed Economizer, the Economizer must be ordered with No Exhaust option. Barometric Relief Dampers must also be ordered separately for field installation.

OUTDOOR AIR

Factory or Field Installed

Outdoor Air Dampers - Downflow or Horizontal With Air Hood

- Single blade damper
- 0 to 25% (fixed) outdoor air adjustable
- Installs in unit
- Includes outdoor air hood
- Automatic model features fully modulating spring return damper motor with plug-in connection
- Manual model features a slide damper
- Maximum mixed air temperature in cooling mode: 30°C

OPTIONS / ACCESSORIES

ROOF CURBS

Field Installed

- Nailer strip furnished
- Mates to unit
- US National Roofing Contractors Approved
- Shipped knocked down

Hybrid Roof Curbs

- Downflow
- Interlocking tabs fasten corners together
- No tools required
- Can also be fastened together with furnished hardware
- Available in 203, 356, 457, and 610 mm heights

Full Perimeter Curbs, Downflow (060H and 074 Models Only)

- Hybrid roof curbs can be assembled using interlocking tabs to fasten corners together
- No tools required
- Can also be fastened together with furnished hardware
- Available in 203, 356, 457, and 610 mm heights

NOTE - 060H and 074 models can be used on smaller 2026 mm Hybrid Roof Curbs (not full perimeter) with 400 mm overhang at condenser end of unit. See dimension drawing on page 42.

Adjustable Pitch Curb

- Downflow
- Fully adjustable pitch curbs (3/4 in. per foot in any direction) provide a level platform for rooftop units allowing flexible installations on roofs with uneven or sloped angles
- Uses interlocking tabs to fasten corners together. No tools required
- Hardware is furnished to connect upper curb with lower curb
- Available in 356 mm height

Adaptor Curbs (not shown)

- Curbs are regionally sourced
- Dimensions vary based upon the source

NOTE - Contact your local sales representative for a detailed cut sheet with applicable dimensions.

CEILING DIFFUSERS

Field Installed

Ceiling Diffusers (Flush or Step-Down)

- White powder coat finish on diffuser face and grilles
- Insulated UL listed duct liner
- Diffuser box has collars for duct connection
- Step-down diffusers have double deflection blades
- Flush diffusers have fixed blades
- Provisions for suspending
- Internally sealed to prevent recirculation
- Removable return air grille
- Adapts to T-bar ceiling grids or plaster ceilings

Transitions (Supply and Return)

- Used with diffusers
- Installs in roof curb
- Galvanized steel construction
- Flanges furnished for duct connection to diffusers
- Fully insulated

OPTIONAL CONVENTIONAL TEMPERATURE CONTROL SYSTEMS

Comfortsense® 7500 Commercial 7-Day Programmable Thermostat



- Four-Stage Heating / Two-Stage Cooling
- Universal Multi-Stage
- Intuitive Touchscreen Interface
- Automatic Changeover between Heating and Cooling
- Full Seven-Day Programming
- Four Time Periods Per Day
- Temperature and Humidity Control
- One-Touch Away Mode
- Holiday Scheduling
- Smooth Setback Recovery (SSR)
- Performance Reports
- Notifications/Reminders
- Dehumidification/Humiditrol® Control for Split Systems and Rooftop Units
- Economizer Relay Control
- Backlit Display
- Wallplate Furnished
- FDD, ASHRAE and IECC Compliant

Comfortsense® 3000 Commercial 5-2 Day Programmable Thermostat



- Two-Stage Heating / Two-Stage Cooling
- Conventional Systems
- Intuitive Interface
- 5-2 Day Programming
- Program Hold
- Remote Indoor Temperature Sensing
- Smooth Setback Recovery (SSR)
- Economizer Relay Control
- Maintenance/Filter/Service Reminders
- Backlit Display
- Wallplate Furnished
- Simple Up and Down Temperature Control

Bacnet Compatible Thermostat With Reheat Function



- 7-Day Programmable
- For units with or without Humiditrol®
- BTL listed MS/TP ensures compatibility with any BACnet system
- Built-in control programs for conventional and heat pump applications
- Conventional systems up to 3-stage heat and 3-stage cool
- Heat pumps with 1 or 2 compressors and up to 2-stage auxiliary heat
- On-board temperature and humidity sensor
- Multiple configurable inputs and outputs enable advanced control strategies
- Set-up Wizard enables rapid system configuration
- No special tools required for installation or commissioning
- Seven-day (2, 4 or 6 event) occupancy scheduling per day
- Backlit 5-inch LCD touchscreen

Description	Catalog No.
ComfortSense® 7500 Commercial 7-Day Programmable Thermostat	
CS7500 7-Day Thermostat	17G74
Sensors/	¹ Remote non-adjustable wall-mount 20k 47W36
Accessories	¹ Remote non-adjustable wall-mount 10k 47W37
	Remote non-adjustable discharge air (duct mount) 19L22
	Outdoor temperature sensor X2658
ComfortSense® 3000 5-2 Day Programmable	
CS3000 5-2 Day Thermostat	11Y05
Sensor/	Remote non-adjustable wall mount 10k averaging 47W37
Accessories	Thermostat wall mounting plate X2659
BACnet	² 7-Day BACnet Thermostat Y8241
Controls	³ BACnet Module (factory or field) 16X70
⁴ BACnet	With Display 97W23
Room Sensors	Without Display 97W24
Universal Thermostat Guard with Lock (clear)	
	Inside Dimensions (H x W) 5 7/8 x 8 3/8 in. 39P21

¹ Remote wall-mount sensors can be applied in any of the following combinations:
One Sensor - (1) 47W36, Two Sensors - (2) 47W37, Three Sensors - (2) 47W36 and (1) 47W37
Four Sensors - (4) 47W36, Five Sensors - (3) 47W36 and (2) 47W37

² BACnet Thermostat (Y8241) will control units with and without the Humiditrol® option. If there is a mix of units equipped with and without Humiditrol on the same site, this thermostat can be used for all units if suitable.

³ Not compatible with units equipped with Humiditrol® option.

⁴ Only compatible with BACnet Module (16X70).

OPTIONS / ACCESSORIES

Item	Model No.	Catalog No.	Unit Model Number			
			KHB 036	KHB 048	KHB 060	KHB 074
CE MARK (STANDARD EFFICIENCY MODELS ONLY)						
CE Marked Unit			¹ O	¹ O	¹ O	¹ O
COOLING SYSTEM						
Condensate Drain Trap	Polyvinyl Chloride (PVC) - C1TRAP20AD2	22H54	X	X	X	O
	Copper - C1TRAP10AD2	76W27	X	X	X	X
Drain Pan Overflow Switch	K1SNSR71AB1-	74W42	X	X	X	X
Low Ambient Kit	Standard Efficiency - K1SNSR13A-2	14D96	X	X	X	X
	High Efficiency - K1SNSR34*A0	15C84	X	X	X	
Efficiency	Standard		O	O	O	O
		High	O	O	O	
Refrigerant Type	R-410A		O	O	O	O
BLOWER - SUPPLY AIR						
Motor	Belt Drive - 1.5 kW (Single-Speed)	Factory	¹ O	¹ O	¹ O	
	Belt Drive - 1.24 kW (Two-Speed)	Factory				O
	Belt Drive - 0.47 kW (Two-Speed)	Factory	² O	² O		
	Belt Drive - 0.62 kW (Two-Speed)	Factory	² O		² O	
	Belt Drive - 1.24 kW (Two-Speed)	Factory		² O	² O	
Drive Kits See Blower Data Tables for selection	Kit A01 - T1DRKT001-1 - 561 - 842 rev/min	Factory	O			
	Kit A02 - T1DRKT002-1 - 621 - 931 rev/min	Factory		O		
	Kit A03 - T1DRKT003-1 - 694 - 1042 rev/min	Factory			O	
	Kit A04 - T1DRKT004-1 - 807 - 1117 rev/min	Factory				O
	Kit A05 - T1DRKT005-1 - 748 - 1122 rev/min	Factory	O			
	Kit A06 - T1DRKT006-1 - 893 - 1191 rev/min	Factory		O		
	Kit A07 - T1DRKT007-1 - 1010 - 1290 rev/min	Factory			O	
	Kit A08 - T1DRKT008-1 - 994 - 1326 rev/min	Factory				O
CABINET						
Combination Coil/Hail Guards	C1GARD51A-1	13R98	X			
	C1GARD51AT1	13T03		X		
	C1GARD51AT1	13T17			X	X
Corrosion Protection		Factory	O	O	O	O
Hinged Access Panels		Factory	O	O	O	O
CONTROLS						
NOTE - Also see Conventional Thermostat Control Systems on page 10 for Additional Options.						
Smoke Detector - Supply or Return (Power board and one sensor)	C1SNSR44AP1	21Z11	X	X	X	X
Smoke Detector - Supply and Return (Power board and two sensors)	C1SNSR43AP1	21Z12	X	X	X	X

¹ Standard Efficiency Models.

² High Efficiency Models.

NOTE - The catalog and model numbers that appear here are for ordering field installed accessories only.

OX - Field Installed or Configure to Order (Factory installed)

O - Configure to Order (Factory Installed)

X - Field Installed.

OPTIONS / ACCESSORIES

Item	Model No.	Catalog No.	Unit Model Number			
			KHB 036	KHB 048	KHB 060	KHB 074
ECONOMIZER						
Standard Economizer With Outdoor Air Hood (Sensible Control)						
Standard Economizer - Includes Barometric Relief Dampers and Exhaust Hood	K1ECON30A-3-	14D90	OX	OX	OX	OX
Economizer - No Exhaust		Factory	O	O	O	O
Standard Economizer Controls						
Single Enthalpy Control	C1SNSR64FF1	21Z09	OX	OX	OX	OX
Differential Enthalpy Control (order 2)	C1SNSR64FF1	21Z09	X	X	X	X
High Performance Economizer With Outdoor Air Hood (Sensible Control)						
High Performance Economizer - Includes Barometric Relief Dampers and Exhaust Hood	K1ECON32A-4	20H49	OX	OX	OX	OX
High Performance Economizer - No Exhaust		Factory	O	O	O	X
High Performance Economizer Controls						
Single Enthalpy Control	C1SNSR60FF1	10Z75	OX	OX	OX	OX
Differential Enthalpy Control (order 2)	C1SNSR60FF1	10Z75	X	X	X	X
Economizer Accessories						
Horizontal Economizer Conversion Kit	T1HECK00AN1	17W45	X	X	X	X
POWER EXHAUST FAN						
Standard Static <i>NOTE - Field installed Power Exhaust Fan requires "Barometric Relief Dampers for Power Exhaust Kit" for field installation. See below.</i>	380/420V-3ph - C1PWRE10A-1M	21Z16	X	X	X	X
BAROMETRIC RELIEF						
¹ Barometric Relief Dampers for Power Exhaust Kit	C1DAMP50A-3-	21Z21	X	X	X	X
² Horizontal Barometric Relief Dampers With Exhaust Hood	LAGEDH03/15-2	19F01	X	X	X	X
OUTDOOR AIR						
Outdoor Air Dampers - Includes Outdoor Air Hood						
Manual	C1DAMP11A-2	15D18	OX	OX	OX	OX
Motorized	C1DAMP21A-1	15D17	OX	OX	OX	OX
ELECTRICAL						
Voltage 50 hz with neutral (No neutral on CE marked models)	380/420V - 3 phase		O	O	O	O
³ ELECTRIC HEAT						
5.7 kW	K1EH0057AN1M	67W92	X	X	X	X
11.5 kW	K1EH0115AN1M	67W93	X	X	X	X
17.2 kW	K1EH0172AN1M	67W94			X	X
23 kW	K1EH0230N-1M	67W95				X

¹ Required when Economizer is factory installed with field installed Power Exhaust Fan option.

² Required when Economizer is configured for horizontal airflow.

³ Nominal kW at 420V-3ph-50hz.

NOTE - The catalog and model numbers that appear here are for ordering field installed accessories only.

OX - Field Installed or Configure to Order (Factory installed)

O - Configure to Order (Factory Installed)

X - Field Installed.

OPTIONS / ACCESSORIES

Item	Model No.	Catalog No.	Unit Model Number			
			KHB 036	KHB 048	KHB 060	KHB 074
INDOOR AIR QUALITY						
Air Filters						
Healthy Climate® High Efficiency Air Filters	MERV 8 (406 x 508 x 51) - C1FLTR15A-1-	54W20	X			
	MERV 13 (406 x 508 x 51) - T1FLTR40A-1-	52W37	X			
Order 4 per unit	MERV 8 (508 x 508 x 51) - C1FLTR15D-1-	54W21		X	X	X
	MERV 13 (508 x 508 x 51) - C1FLTR40D-1-	52W39		X	X	X
Indoor Air Quality (CO₂) Sensors						
Sensor - Wall-mount, off-white plastic cover with LCD display	C0SNSR50AE1L	77N39	X	X	X	X
Sensor - Wall-mount, black plastic case, no display, rated for plenum mounting	C0SNSR53AE1L	87N54	X	X	X	X
CO ₂ Sensor Duct Mounting Kit - for downflow applications	C0MISC19AE1-	85L43	X	X	X	X
Aspiration Box - for duct mounting non-plenum rated CO ₂ sensor (77N39)	C0MISC16AE1-	90N43	X	X	X	X
UVC Germicidal Lamps						
¹ Healthy Climate® UVC Light Kit (220V-1ph)	E1UVCL10AN1-	50W90	X	X	X	X
ROOF CURBS						
Hybrid Roof Curbs, Downflow						
203 mm height	C1CURB70A-1	11F50	X	X	² X	² X
356 mm height	C1CURB71A-1	11F51	X	X	² X	² X
457 mm height	C1CURB72A-1	11F52	X	X	² X	² X
610 mm height	C1CURB73A-1	11F53	X	X	² X	² X
Hybrid Roof Curbs, Full Perimeter, Downflow						
203 mm height	K1CURB70AP1	11S47			³ X	X
356 mm height	K1CURB71AP1	11S48			³ X	X
457 mm height	K1CURB72AP1	11T01			³ X	X
610 mm height	K1CURB73AP1	11T06			³ X	X
Adjustable Pitch Curb, Downflow						
356 mm height	C1CURB55AT1	43W27	X	X	² X	² X
CEILING DIFFUSERS						
Step-Down - Order one	RTD9-65S	13K60	X	X	X	
	RTD11-95S	13K61				X
Flush - Order one	FD9-65S	13K55	X	X	X	
	FD11-95S	13K56				X
Transitions (Supply and Return) - Order one	T1TRAN10AN1	17W53	X	X	X	
	T1TRAN20N-1	17W54				X

¹ Lamps operate on 220V single-phase power supply. Step-down transformer must be field supplied for field installation for 380/420V primary to 220V secondary. Alternately, a separate 220V power supply may be used to directly power the UVC ballast(s).

² 060H and 074 models will fit smaller roof curbs with overhang. See dimension drawing on page 38.

³ 060S models cannot be used on full perimeter curbs.

NOTE - The catalog and model numbers that appear here are for ordering field installed accessories only.

OX - Field Installed or Configure to Order (Factory installed)

O - Configure to Order (Factory Installed)

X - Field Installed.

SPECIFICATIONS
STANDARD EFFICIENCY

General Data		Nominal Size	10.5 kW (3 Ton)	14 kW (4 Ton)	17.5 kW (5 Ton)	21 kW (6 Ton)	
		Model No.	KHB036S4B	KHB048S4B	KHB060S4B	KHB074S4T	
		Efficiency Type	Standard	Standard	Standard	Standard	
		Blower Type	Single Speed Belt Drive	Single Speed Belt Drive	Single Speed Belt Drive	Two-Speed Belt Drive	
Cooling Performance	Gross Cooling Capacity - kW (Btuh)		9.3 (31 700)	12.3 (41 900)	15.8 (54 000)	18.0 (61 500)	
	Net Cooling Capacity - kW (Btuh)		¹ 8.9 (30 300)	¹ 11.7 (39 900)	¹ 15.2 (51 800)	² 17.3 (58 900)	
	AHRI Rated Air Flow - L/s (cfm)		565 (1200)	790 (1670)	955 (2020)	991 (2100)	
	³ Sound Rating Number (dB)		75	75	80	83	
	Total Unit Power - kW		2.6	3.5	4.2	5.3	
	SEER (Btuh/Watt)		¹ 13.8	¹ 14.0	¹ 14.0	---	
	EER (Btuh/Watt)		¹ 11.6	¹ 11.3	¹ 12.2	² 11.1	
	IEER (Btuh/Watt)		---	---	---	² 14.5	
Refrigerant	Type		R-410A	R-410A	R-410A	R-410A	
	Charge Furnished		5.44 kg (12 lbs. 0 oz.)	6.55 kg (14 lbs. 7 oz.)	7.26 kg (16 lbs. 0 oz.)	10.88 kg (24 lbs. 0 oz.)	
Heating Performance	Total High Heating Capacity - kW (Btuh)		9.2 (31 500)	12.5 (42 500)	14.8 (50 500)	18.4 (63 000)	
	Total Unit Power - kW		2.4	3.1	3.7	5.8	
	COP		3.8	3.96	3.96	3.30	
	Total Low Heating Capacity - kW (Btuh)		5.3 (18 200)	7.5 (25 600)	8.7 (29 800)	10.5 (36 000)	
	Total Unit Power - kW		2.3	3.0	3.8	4.7	
	COP		2.30	2.49	2.30	2.25	
Electric Heating Options			See Electric Heat Table, page 33				
Compressor Type (one per unit)			Scroll	Scroll	Scroll	Scroll	
Outdoor Coil	Net face area - m ² (sq. ft.)		1.45 (15.6)	1.79 (19.3)	1.79 (19.3)	2.6 (28.0)	
	Tube diameter - mm (in.)		9.5 (3/8)	9.5 (3/8)	9.5 (3/8)	9.5 (3/8)	
	Number of rows		2	2	3	2	
	Fins per meter (Fins / inch)		788 (20)	788 (20)	788 (20)	788 (20)	
Outdoor Coil Fan	Motor W (HP)		187 (1/4)	187 (1/4)	249 (1/3)	374 (1/2)	
	Motor rev/min		690	690	900	900	
	Total motor watts		180	220	310	387	
	Diameter - mm (in.) / No. of blades		610 (24) - 3	610 (24) - 3	610 (24) - 3	610 (24) - 4	
	Total air volume - L/s (cfm)		1300 (2750)	1535 (3250)	1690 (3580)	2260 (4780)	
Indoor Coil	Net face area - m ² (sq. ft.)		0.7 (7.8)	0.9 (9.7)	0.9 (9.7)	0.90 (9.7)	
	Tube diameter - mm (in.)		9.5 (3/8)	9.5 (3/8)	9.5 (3/8)	9.5 (3/8)	
	Number of rows		3	3	4	4	
	Fins per meter (Fins / inch)		552 (14)	552 (14)	552 (14)	552 (14)	
	Drain Connection (no. and size) - in.		(1) 1 NPT	(1) 1 NPT	(1) 1 NPT	(1) 1 NPT	
	Expansion device type		Balanced Port Thermostatic Expansion Valve, removeable power head				
⁴ Indoor Blower & Drive Selection	Nominal Motor Output kW (hp)		1.5 (2)	1.5 (2)	1.5 (2)	1.2 (1.66)	
	Maximum Usable Motor kW (hp)		1.7 (2.3)	1.7 (2.3)	1.7 (2.3)	1.4 (1.92)	
	Drive Kit (rev/min range)	A01		(561 - 842)	(621 - 931)	(694 - 1042)	(807 - 1117)
		A05		(748 - 1122)	(893 - 1191)	(1010 - 1290)	(994-1326)
		A02					
Wheel nom. diameter x width - mm (in.)		254 x 254 (10 x 10)					
Filters	Type		Disposable				
	Number and size - mm (in.)		(4) 406 x 508 x 51 (16 x 20 x 2)	(4) 508 x 508 x 51 (20 x 20 x 2)			
Electrical Characteristics - 50 hz			380/420V - 50 hertz - 3 phase with neutral (No neutral on CE marked models)				

NOTE - Net capacity includes evaporator blower motor heat deduction. Gross capacity does not include evaporator blower motor heat deduction.

^{1,2} Rating test conditions are those included in Air-Conditioning, Heating and Refrigeration Institute (AHRI) Standard ¹ 210/240 or ² 340/360 while operating at rated voltage and air volumes:

Cooling Ratings - 35°C (95°F) outdoor air temperature and 27°C (80°F) dry bulb/19°C (67°F) wet bulb entering indoor coil air.

High Temperature Heating Ratings - 8°C (47°F) dry bulb/6°C (43°F) wet bulb outdoor air temperature and 21°C (70°F) entering indoor coil air.

Low Temperature Heating Ratings - -8°C (17°F) dry bulb/-9°C (15°F) wet bulb outdoor air temperature and 21°C (70°F) entering indoor coil air.

³ Sound Rating Number rated in accordance with test conditions included in AHRI Standard 270.

⁴ Using total air volume and system static pressure requirements determine from blower performance tables rev/min and motor size required. Maximum usable size of motors furnished is shown. If motors of comparable size are used, be sure to keep within the service factor limitations outlined on the motor nameplate.

SPECIFICATIONS

HIGH EFFICIENCY

General Data		Nominal Size	10.5 kW (3 Ton)	14 kW (4 Ton)	17.5 kW (5 Ton)
		Model No.	KHB036H4T	KHB048H4T	KHB060H4T
		Efficiency Type	High	High	High
		Blower Type	Two-Speed Belt Drive	Two-Speed Belt Drive	Two-Speed Belt Drive
Cooling Performance	Gross Cooling Capacity - kW (Btuh)		9.1 (31 000)	12.1 (41 400)	15.5 (53 000)
	¹ Net Cooling Capacity - kW (Btuh)		8.8 (30 000)	11.6 (39 500)	14.9 (51 000)
	AHRI Rated Air Flow - L/s (cfm)		565 (1200)	755 (1600)	850 (1800)
	² Sound Rating Number (dB)		75	77	77
	Total Unit Power - kW		2.5	3.3	4.2
	¹ SEER (Btuh/Watt)		15.0	15.0	15.0
	¹ EER (Btuh/Watt)		11.9	12.2	12.2
Refrigerant	Type		R-410A	R-410A	R-410A
	Charge Furnished		5.81 kg (12 lbs. 13 oz.)	6.35 kg (14 lbs. 0 oz.)	9.07 (20 lbs. 0 oz.)
Heating Performance	Total High Heating Capacity - kW (Btuh)		8.8 (30 000)	11.6 (39 500)	14.6 (50 000)
	Total Unit Power - kW		2.4	3.0	3.9
	COP		3.70	3.90	3.80
	Total Low Heating Capacity - kW (Btuh)		4.8 (16 300)	6.3 (21 600)	8.3 (28 200)
	Total Unit Power - kW		2.2	2.7	3.6
	COP		2.20	2.32	2.30
Electric Heating Options		See Electric Heat Table, page 33			
Compressor Type (one per unit)			Two-Stage Scroll	Two-Stage Scroll	Two-Stage Scroll
Outdoor Coil	Net face area - m ² (sq. ft.)		1.5 (15.6)	1.8 (19.3)	2.6 (28.0)
	Tube diameter - mm (in.)		9.5 (3/8)	9.5 (3/8)	9.5 (3/8)
	Number of rows		2	2	2
	Fins per meter (Fins / inch)		788 (20)	788 (20)	788 (20)
Outdoor Coil Fan	Motor - W (HP)		(1) 249 (1/3)	(1) 249 (1/3)	(1) 249 (1/3)
	Motor rev/min		775 / 650	850 / 700	930 / 785
	Total Motor Input - watts		190 / 120	250 / 140	280 / 200
	Diameter - mm (in.) / No. of blades		610 (24) / 3	610 (24) / 3	610 (24) / 3
	Total air volume - L/s (cfm)		1650/1400 (3500/2970)	1915/1570 (4060/3330)	1955/1595 (4140/3380)
Indoor Coil	Net face area - m ² (sq. ft.)		0.7 (7.8)	0.9 (9.7)	0.9 (9.7)
	Tube diameter - mm (in.)		9.5 (3/8)	9.5 (3/8)	9.5 (3/8)
	Number of rows		3	3	4
	Fins per meter (Fins per inch)		551 (14)	551 (14)	551 (14)
	Drain Connection (no. and size) - in.		(1) 1 NPT	(1) 1 NPT	(1) 1 NPT
	Expansion device type		Balanced Port Thermostatic Expansion Valve, removable power head		
³ Indoor Blower & Drive Selection	Nominal Motor kW (hp)		0.47 (0.63)	0.47 (0.63)	0.62 (0.83)
	Maximum Usable Motor kW (hp)		0.54 (0.72)	0.54 (0.72)	0.71 (0.95)
	Drive Kit (rev/min range)		A01 (low 374 - 561) (high 546 - 842)	A02 (low 414 - 621) (high 621 - 931)	A03 (low 463 - 694) (high 694 - 1042)
	Nominal Motor kW (hp)		0.62 (0.83)	1.24 (1.66)	1.24 (1.66)
	Maximum Usable Motor kW (hp)		0.71 (0.95)	1.42 (1.91)	1.42 (1.91)
	Drive Kit (rev/min range)		A05 (low 498 - 748) (high 748 - 1122)	A06 (low 595 - 794) (high 893 - 1191)	A07 (low 673 - 860) (high 1010 - 1290)
	Wheel nom. diameter x width - mm (in.)		254 x 254 (10 x 10)		
	Filters	Type		Disposable	Disposable
Number and size - mm (in.)			(4) 406 x 508 x 51 (16 x 20 x 2)	(4) 508 x 508 x 51 (20 x 20 x 2)	
Electrical Characteristics - 50 hz		380/420V - 50 hertz - 3 phase with neutral			

NOTE - Net capacity includes evaporator blower motor heat deduction. Gross capacity does not include evaporator blower motor heat deduction.

¹ Rating test conditions are those included in Air-Conditioning, Heating and Refrigeration Institute (AHRI) Standard 210/240 while operating at rated voltage and air volumes:

Cooling Ratings - 35°C (95°F) outdoor air temperature and 27°C (80°F) dry bulb/19°C (67°F) wet bulb entering indoor coil air.

High Temperature Heating Ratings - 8°C (47°F) dry bulb/6°C (43°F) wet bulb outdoor air temperature and 21°C (70°F) entering indoor coil air.

Low Temperature Heating Ratings - -8°C (17°F) dry bulb/-9°C (15°F) wet bulb outdoor air temperature and 21°C (70°F) entering indoor coil air.

² Sound Rating Number (SRN) rated in accordance with test conditions included in ARI Standard 270-95.

³ Using total air volume and system static pressure requirements determine from blower performance tables rev/min and motor size required. Maximum usable size of motors furnished is shown. If motors of comparable size are used, be sure to keep within the service factor limitations outlined on the motor nameplate.

COOLING / HEATING RATINGS

STANDARD EFFICIENCY

NOTE - For Temperatures and Capacities not shown in tables, see bulletin - Cooling Unit Rating Table Correction Factor Data in Miscellaneous Engineering Data section.

10.5 KW - KHB036S4 - STANDARD EFFICIENCY - COOLING CAPACITY

Entering Wet Bulb Temperature	Total Air Volume	Outdoor Air Temperature Entering Outdoor Coil																			
		26.7°C					35°C					43.3°C					46°C				
		Total Cool Cap.	Comp. Motor Input	Sensible To Total Ratio (S/T)			Total Cool Cap.	Comp. Motor Input	Sensible To Total Ratio (S/T)			Total Cool Cap.	Comp. Motor Input	Sensible To Total Ratio (S/T)			Total Cool Cap.	Comp. Motor Input	Sensible To Total Ratio (S/T)		
				Dry Bulb					Dry Bulb					Dry Bulb					Dry Bulb		
L/s	kW	kW	24°C	27°C	29°C	kW	kW	24°C	27°C	29°C	kW	kW	24°C	27°C	29°C	kW	kW	24°C	27°C	29°C	
17.2°C	455	9.20	1.64	0.75	0.91	1.00	8.30	1.97	0.77	0.96	1.00	7.20	2.38	0.81	1.00	1.00	6.9	2.53	0.83	1	1
	565	9.80	1.65	0.82	1.00	1.00	8.90	1.98	0.85	1.00	1.00	7.90	2.39	0.90	1.00	1.00	7.5	2.54	0.93	1	1
	680	10.30	1.66	0.89	1.00	1.00	9.30	1.99	0.93	1.00	1.00	8.30	2.40	0.99	1.00	1.00	7.9	2.55	1	1	1
19.4°C	455	9.80	1.65	0.58	0.73	0.88	8.90	1.98	0.58	0.75	0.92	7.70	2.39	0.59	0.78	0.98	7.3	2.54	0.6	0.81	0.99
	565	10.30	1.66	0.62	0.80	0.97	9.30	1.99	0.63	0.83	1.00	8.10	2.40	0.65	0.88	1.00	7.7	2.54	0.66	0.9	1
	680	10.70	1.67	0.66	0.86	1.00	9.60	2.00	0.68	0.90	1.00	8.40	2.40	0.71	0.97	1.00	8	2.55	0.73	0.99	1
21.7°C	455	10.50	1.66	0.42	0.57	0.71	9.50	1.99	0.42	0.58	0.73	8.30	2.40	0.40	0.59	0.76	7.9	2.55	0.4	0.59	0.78
	565	11.00	1.68	0.45	0.61	0.78	9.90	2.00	0.44	0.63	0.81	8.70	2.41	0.43	0.64	0.85	8.3	2.55	0.43	0.66	0.88
	680	11.30	1.69	0.47	0.66	0.84	10.20	2.01	0.46	0.68	0.88	8.90	2.41	0.46	0.70	0.94	8.5	2.56	0.47	0.72	0.97

Entering Wet Bulb Temperature	Total Air Volume	Outdoor Air Temperature Entering Outdoor Coil														
		48°C					50°C					51.7°C				
		Total Cool Cap.	Comp. Motor Input	Sensible To Total Ratio (S/T)			Total Cool Cap.	Comp. Motor Input	Sensible To Total Ratio (S/T)			Total Cool Cap.	Comp. Motor Input	Sensible To Total Ratio (S/T)		
				Dry Bulb					Dry Bulb					Dry Bulb		
L/s	kW	kW	24°C	27°C	29°C	kW	kW	24°C	27°C	29°C	kW	kW	24°C	27°C	29°C	
17.2°C	455	6.7	2.65	0.84	1	1	6.4	2.78	0.86	1	1	6.20	2.90	0.86	1.00	1.00
	565	7.2	2.66	0.94	1	1	7	2.79	0.96	1	1	6.70	2.90	0.98	1.00	1.00
	680	7.7	2.67	1	1	1	7.4	2.79	1	1	1	7.20	2.91	1.00	1.00	1.00
19.4°C	455	7.1	2.66	0.6	0.82	1	6.8	2.79	0.61	0.83	1	6.50	2.90	0.61	0.83	1.00
	565	7.4	2.66	0.67	0.92	1	7.1	2.79	0.68	0.94	1	6.90	2.91	0.68	0.95	1.00
	680	7.7	2.67	0.74	1	1	7.4	2.79	0.74	1	1	7.20	2.91	0.75	1.00	1.00
21.7°C	455	7.6	2.67	0.4	0.6	0.8	7.3	2.79	0.39	0.61	0.81	7.00	2.91	0.39	0.61	0.81
	565	7.9	2.67	0.43	0.66	0.89	7.6	2.8	0.43	0.68	0.91	7.40	2.91	0.42	0.68	0.92
	680	8.2	2.68	0.46	0.73	0.98	7.9	2.8	0.46	0.74	1	7.60	2.91	0.46	0.75	1.00

10.5 KW - KHB036S4 - STANDARD EFFICIENCY - HEATING CAPACITY

Indoor Coil Air Volume 21°C Dry Bulb	Air Temperature Entering Outdoor Coil									
	18°C		7°C		-4°C		-15°C		-28°C	
	Total Heating Capacity	Comp. Motor Input	Total Heating Capacity	Comp. Motor Input	Total Heating Capacity	Comp. Motor Input	Total Heating Capacity	Comp. Motor Input	Total Heating Capacity	Comp. Motor Input
L/s	kW	kW	kW	kW	kW	kW	kW	kW	kW	kW
453	11.3	2.01	8.6	1.91	5.9	1.81	3.9	1.63	2.00	1.21
566	11.5	1.90	8.8	1.80	6.0	1.70	4.0	1.52	2.10	1.10
680	11.6	1.85	8.9	1.74	6.1	1.64	4.1	1.46	2.20	1.04

COOLING / HEATING RATINGS

STANDARD EFFICIENCY

NOTE - For Temperatures and Capacities not shown in tables, see bulletin - Cooling Unit Rating Table Correction Factor Data in Miscellaneous Engineering Data section.

14 KW - KHB048S4 - STANDARD EFFICIENCY - COOLING CAPACITY

Entering Wet Bulb Temperature	Total Air Volume	Outdoor Air Temperature Entering Outdoor Coil																			
		26.7°C					35°C					43.3°C					46°C				
		Total Cool Cap.	Comp. Motor Input	Sensible To Total Ratio (S/T)			Total Cool Cap.	Comp. Motor Input	Sensible To Total Ratio (S/T)			Total Cool Cap.	Comp. Motor Input	Sensible To Total Ratio (S/T)			Total Cool Cap.	Comp. Motor Input	Sensible To Total Ratio (S/T)		
				Dry Bulb					Dry Bulb					Dry Bulb					Dry Bulb		
L/s	kW	kW	24°C	27°C	29°C	kW	kW	24°C	27°C	29°C	kW	kW	24°C	27°C	29°C	kW	kW	24°C	27°C	29°C	
17.2°C	605	12.3	2.23	0.75	0.91	1.00	10.70	2.69	0.76	0.96	1.00	9.10	3.27	0.79	1.00	1.00	29.3	3.49	0.81	1	1
	755	13.1	2.24	0.82	1.00	1.00	11.60	2.71	0.85	1.00	1.00	10.10	3.30	0.89	1.00	1.00	32.4	3.51	0.92	1	1
	905	14	2.25	0.89	1.00	1.00	12.40	2.72	0.94	1.00	1.00	10.70	3.31	0.99	1.00	1.00	34.7	3.53	1	1	1
19.4°C	605	13.2	2.24	0.57	0.73	0.88	11.50	2.70	0.56	0.74	0.92	9.80	3.29	0.56	0.77	0.98	31.5	3.5	0.56	0.79	1
	755	13.9	2.25	0.62	0.80	0.97	12.20	2.72	0.62	0.83	1.00	10.40	3.30	0.62	0.87	1.00	33.4	3.52	0.64	0.9	1
	905	14.5	2.26	0.66	0.87	1.00	12.70	2.73	0.67	0.92	1.00	10.80	3.32	0.69	0.97	1.00	34.9	3.53	0.7	0.99	1
21.7°C	605	14.1	2.25	0.41	0.56	0.70	12.40	2.72	0.38	0.56	0.72	10.60	3.31	0.36	0.56	0.75	34.4	3.53	0.34	0.56	0.77
	755	14.9	2.27	0.44	0.61	0.78	13.10	2.74	0.42	0.62	0.81	11.20	3.32	0.39	0.63	0.85	36.1	3.54	0.39	0.64	0.88
	905	15.4	2.28	0.46	0.66	0.85	13.50	2.75	0.44	0.67	0.89	11.60	3.34	0.42	0.69	0.95	37.5	3.55	0.42	0.71	0.97

Entering Wet Bulb Temperature	Total Air Volume	Outdoor Air Temperature Entering Outdoor Coil														
		48°C					50°C					51.7°C				
		Total Cool Cap.	Comp. Motor Input	Sensible To Total Ratio (S/T)			Total Cool Cap.	Comp. Motor Input	Sensible To Total Ratio (S/T)			Total Cool Cap.	Comp. Motor Input	Sensible To Total Ratio (S/T)		
				Dry Bulb					Dry Bulb					Dry Bulb		
L/s	kW	kW	24°C	27°C	29°C	kW	kW	24°C	27°C	29°C	kW	kW	24°C	27°C	29°C	
17.2°C	605	28	3.66	0.82	1	1	26.6	3.84	0.83	1	1	7.40	4.01	0.84	1.00	1.00
	755	30.9	3.68	0.94	1	1	29.4	3.86	0.96	1	1	8.20	4.03	0.98	1.00	1.00
	905	33.2	3.7	1	1	1	31.6	3.89	1	1	1	8.90	4.05	1.00	1.00	1.00
19.4°C	605	29.8	3.67	0.56	0.8	1	28.3	3.86	0.56	0.81	1	7.90	4.02	0.55	0.82	1.00
	755	31.7	3.69	0.64	0.92	1	29.9	3.87	0.64	0.94	1	8.30	4.04	0.64	0.96	1.00
	905	33.3	3.7	0.71	1	1	31.7	3.89	0.72	1	1	8.90	4.05	0.73	1.00	1.00
21.7°C	605	32.7	3.7	0.34	0.56	0.78	30.9	3.88	0.33	0.56	0.79	8.60	4.04	0.31	0.56	0.80
	755	34.4	3.71	0.38	0.64	0.89	32.5	3.89	0.37	0.65	0.91	9.10	4.06	0.36	0.65	0.93
	905	35.7	3.73	0.42	0.72	0.99	33.9	3.91	0.41	0.73	1	9.50	4.07	0.41	0.73	1.00

14 KW - KHB048S4 - STANDARD EFFICIENCY - HEATING CAPACITY

Indoor Coil Air Volume 21°C Dry Bulb	Air Temperature Entering Outdoor Coil									
	18°C		7°C		-4°C		-15°C		-28°C	
	Total Heating Capacity	Comp. Motor Input	Total Heating Capacity	Comp. Motor Input	Total Heating Capacity	Comp. Motor Input	Total Heating Capacity	Comp. Motor Input	Total Heating Capacity	Comp. Motor Input
L/s	kW	kW	kW	kW	kW	kW	kW	kW	kW	kW
605	15.1	2.58	11.6	2.49	8.0	2.40	5.4	2.19	2.7	1.62
755	15.3	2.42	11.9	2.33	8.3	2.24	5.7	2.03	2.9	1.46
905	15.6	2.32	12.1	2.23	8.6	2.14	5.9	1.93	3.2	1.37

COOLING / HEATING RATINGS

STANDARD EFFICIENCY

NOTE - For Temperatures and Capacities not shown in tables, see bulletin - Cooling Unit Rating Table Correction Factor Data in Miscellaneous Engineering Data section.

17.5 KW - KHB060S4 - STANDARD EFFICIENCY - COOLING CAPACITY

Entering Wet Bulb Temperature	Total Air Volume	Outdoor Air Temperature Entering Outdoor Coil																							
		26.7°C						35°C						43.3°C						46°C					
		Total Cool Cap.	Comp. Motor Input	Sensible To Total Ratio (S/T)			Total Cool Cap.	Comp. Motor Input	Sensible To Total Ratio (S/T)			Total Cool Cap.	Comp. Motor Input	Sensible To Total Ratio (S/T)			Total Cool Cap.	Comp. Motor Input	Sensible To Total Ratio (S/T)						
				Dry Bulb					Dry Bulb					Dry Bulb					Dry Bulb						
L/s	kW	kW	24°C	27°C	29°C	kW	kW	24°C	27°C	29°C	kW	kW	24°C	27°C	29°C	kW	kW	24°C	27°C	29°C					
17.2°C	755	15.7	2.71	0.73	0.91	1.00	14.00	3.24	0.75	0.96	1.00	12.20	3.94	0.77	1.00	1.00	11.6	4.19	0.82	1	1				
	945	16.6	2.72	0.79	1.00	1.00	15.10	3.26	0.83	1.00	1.00	13.30	3.96	0.89	1.00	1.00	12.7	4.23	0.93	1	1				
	1135	17.7	2.74	0.87	1.00	1.00	16.00	3.28	0.93	1.00	1.00	14.10	3.98	1.00	1.00	1.00	13.5	4.25	1	1	1				
19.4°C	755	16.9	2.72	0.56	0.70	0.86	15.00	3.26	0.56	0.72	0.92	13.10	3.96	0.56	0.76	0.98	12.4	4.22	0.58	0.80	1				
	945	17.7	2.73	0.60	0.77	0.98	15.80	3.27	0.61	0.80	1.00	13.70	3.97	0.62	0.86	1.00	13.0	4.24	0.65	0.90	1				
	1135	18.3	2.75	0.64	0.85	1.00	16.40	3.28	0.65	0.90	1.00	14.20	3.99	0.68	0.98	1.00	13.5	4.25	0.72	1	1				
21.7°C	755	18.1	2.74	0.41	0.54	0.68	16.20	3.28	0.39	0.55	0.70	14.10	3.98	0.38	0.56	0.73	13.4	4.25	0.38	0.58	0.78				
	945	18.9	2.75	0.43	0.59	0.75	16.90	3.29	0.42	0.60	0.78	14.70	4.00	0.40	0.62	0.83	14.0	4.27	0.41	0.65	0.88				
	1135	19.6	2.76	0.45	0.63	0.82	17.50	3.30	0.44	0.65	0.87	15.20	4.01	0.43	0.68	0.95	14.4	4.28	0.44	0.72	0.98				

Entering Wet Bulb Temperature	Total Air Volume	Outdoor Air Temperature Entering Outdoor Coil																	
		48°C						50°C						51.7°C					
		Total Cool Cap.	Comp. Motor Input	Sensible To Total Ratio (S/T)			Total Cool Cap.	Comp. Motor Input	Sensible To Total Ratio (S/T)			Total Cool Cap.	Comp. Motor Input	Sensible To Total Ratio (S/T)					
				Dry Bulb					Dry Bulb					Dry Bulb					
L/s	kW	kW	24°C	27°C	29°C	kW	kW	24°C	27°C	29°C	kW	kW	24°C	27°C	29°C				
17.2°C	755	11.1	4.41	0.84	1	1	10.8	4.64	0.85	1	1	10.30	4.84	0.84	1.00	1.00			
	945	12.1	4.44	0.95	1	1	11.7	4.67	0.97	1	1	11.30	4.88	0.99	1.00	1.00			
	1135	13.0	4.47	1	1	1	12.5	4.69	1	1	1	12.00	4.91	1.00	1.00	1.00			
19.4°C	755	11.9	4.43	0.58	0.81	1	11.3	4.66	0.59	0.83	1	10.80	4.86	0.57	0.81	1.00			
	945	12.4	4.45	0.65	0.93	1	11.9	4.68	0.66	0.95	1	11.40	4.89	0.65	0.96	1.00			
	1135	13.0	4.47	0.73	1	1	12.5	4.70	0.74	1	1	12.30	4.92	1.00	1.00	1.00			
21.7°C	755	12.9	4.46	0.37	0.58	0.78	12.3	4.69	0.37	0.59	0.80	11.80	4.90	0.36	0.57	0.78			
	945	13.4	4.48	0.41	0.65	0.90	12.8	4.71	0.40	0.66	0.92	12.30	4.92	0.39	0.65	0.93			
	1135	13.9	4.50	0.44	0.73	0.99	13.3	4.73	0.44	0.74	1	12.50	4.93	0.93	0.93	0.93			

17.5 KW - KHB060S4 - STANDARD EFFICIENCY - HEATING CAPACITY

Indoor Coil Air Volume 21°C Dry Bulb	Air Temperature Entering Outdoor Coil									
	18°C		7°C		-4°C		-15°C		-28°C	
	Total Heating Capacity	Comp. Motor Input	Total Heating Capacity	Comp. Motor Input	Total Heating Capacity	Comp. Motor Input	Total Heating Capacity	Comp. Motor Input	Total Heating Capacity	Comp. Motor Input
L/s	kW	kW	kW	kW	kW	kW	kW	kW	kW	kW
755	18.3	2.94	14.0	2.91	9.6	2.86	6.4	2.73	3.2	2.00
945	18.5	2.77	14.2	2.74	9.8	2.70	6.5	2.56	3.4	1.83
1135	18.7	2.70	14.4	2.66	10.1	2.62	6.8	2.48	3.7	1.75

COOLING / HEATING RATINGS

STANDARD EFFICIENCY

NOTE - For Temperatures and Capacities not shown in tables, see bulletin - Cooling Unit Rating Table Correction Factor Data in Miscellaneous Engineering Data section.

21 kW - KHB074S4 - STANDARD EFFICIENCY - COOLING CAPACITY (1ST STAGE)

Entering Wet Bulb Temperature	Total Air Volume	Outdoor Air Temperature Entering Outdoor Coil																			
		18.1°C					24°C					29°C					35°C				
		Total Cool Cap.	Comp. Motor Input	Sensible To Total Ratio (S/T)			Total Cool Cap.	Comp. Motor Input	Sensible To Total Ratio (S/T)			Total Cool Cap.	Comp. Motor Input	Sensible To Total Ratio (S/T)			Total Cool Cap.	Comp. Motor Input	Sensible To Total Ratio (S/T)		
				Dry Bulb					Dry Bulb					Dry Bulb					Dry Bulb		
L/s	kW	kW	24°C	27°C	29°C	kW	kW	24°C	27°C	29°C	kW	kW	24°C	27°C	29°C	kW	kW	24°C	27°C	29°C	
17.2°C	565	13.5	1.82	0.74	0.88	0.97	12.9	2.10	0.75	0.90	0.99	12.3	2.38	0.76	0.91	1.00	11.5	2.75	0.78	0.94	1.00
	755	14.6	1.81	0.81	0.97	1.00	13.9	2.09	0.82	0.99	1.00	13.3	2.36	0.84	1.00	1.00	12.6	2.73	0.86	1.00	1.00
	945	15.6	1.79	0.87	1.00	1.00	15.0	2.08	0.89	1.00	1.00	14.4	2.34	0.91	1.00	1.00	13.6	2.72	0.94	1.00	1.00
19.4°C	565	14.4	1.81	0.60	0.74	0.83	13.7	2.09	0.61	0.75	0.84	13.1	2.37	0.61	0.76	0.85	12.3	2.74	0.62	0.78	0.88
	755	15.5	1.79	0.65	0.81	0.91	14.7	2.08	0.66	0.83	0.93	14.1	2.35	0.66	0.84	0.95	13.1	2.72	0.67	0.87	0.98
	945	16.3	1.78	0.69	0.88	0.99	15.4	2.07	0.70	0.90	1.00	14.7	2.34	0.71	0.92	1.00	13.8	2.72	0.73	0.95	1.00
21.7°C	565	15.8	1.79	0.42	0.55	0.63	15.1	2.07	0.42	0.55	0.64	14.4	2.34	0.40	0.55	0.64	13.5	2.72	0.40	0.56	0.65
	755	17.0	1.77	0.44	0.59	0.69	16.1	2.06	0.44	0.60	0.70	15.4	2.33	0.44	0.60	0.71	14.4	2.70	0.44	0.61	0.73
	945	17.8	1.75	0.45	0.63	0.75	16.9	2.04	0.45	0.64	0.76	16.1	2.32	0.45	0.64	0.77	15.1	2.70	0.45	0.66	0.79

21 kW - KHB074S4 - STANDARD EFFICIENCY - COOLING CAPACITY (2ND STAGE)

Entering Wet Bulb Temperature	Total Air Volume	Outdoor Air Temperature Entering Outdoor Coil																			
		26.7°C					35°C					43.3°C					46°C				
		Total Cool Cap.	Comp. Motor Input	Sensible To Total Ratio (S/T)			Total Cool Cap.	Comp. Motor Input	Sensible To Total Ratio (S/T)			Total Cool Cap.	Comp. Motor Input	Sensible To Total Ratio (S/T)			Total Cool Cap.	Comp. Motor Input	Sensible To Total Ratio (S/T)		
				Dry Bulb					Dry Bulb					Dry Bulb					Dry Bulb		
L/s	kW	kW	24°C	27°C	29°C	kW	kW	24°C	27°C	29°C	kW	kW	24°C	27°C	29°C	kW	kW	24°C	27°C	29°C	
17.2°C	905	17.6	3.29	0.80	0.96	1.00	16.3	3.97	0.83	1.00	1.00	14.9	4.79	0.86	1.00	1.00	14.4	5.11	0.88	1.00	1.00
	1135	18.8	3.32	0.87	1.00	1.00	17.4	4.00	0.90	1.00	1.00	16.0	4.83	0.95	1.00	1.00	15.4	5.13	0.96	1.00	1.00
	1360	19.8	3.34	0.93	1.00	1.00	18.3	4.02	0.97	1.00	1.00	16.7	4.85	1.00	1.00	1.00	16.2	5.15	1.00	1.00	1.00
19.4°C	905	18.6	3.31	0.64	0.80	0.91	17.1	3.99	0.66	0.84	0.95	15.5	4.82	0.68	0.87	0.99	14.9	5.12	0.69	0.89	1.00
	1135	19.5	3.33	0.69	0.88	0.99	17.8	4.01	0.71	0.91	1.00	16.1	4.83	0.73	0.96	1.00	15.6	5.14	0.75	0.98	1.00
	1360	20.1	3.35	0.73	0.94	1.00	18.4	4.02	0.75	0.98	1.00	16.8	4.85	0.79	1.00	1.00	16.2	5.15	0.81	1.00	1.00
21.7°C	905	20.2	3.35	0.43	0.58	0.68	18.6	4.03	0.42	0.60	0.71	16.9	4.85	0.43	0.61	0.74	16.2	5.16	0.43	0.62	0.75
	1135	21.0	3.37	0.44	0.63	0.74	19.3	4.05	0.45	0.65	0.77	17.5	4.87	0.45	0.67	0.81	16.9	5.17	0.45	0.68	0.82
	1360	21.7	3.39	0.46	0.67	0.80	19.8	4.06	0.46	0.69	0.83	18.0	4.89	0.47	0.72	0.88	17.3	5.19	0.47	0.73	0.89

Entering Wet Bulb Temperature	Total Air Volume	Outdoor Air Temperature Entering Outdoor Coil																	
		48°C					50°C					51.7°C							
		Total Cool Cap.	Comp. Motor Input	Sensible To Total Ratio (S/T)			Total Cool Cap.	Comp. Motor Input	Sensible To Total Ratio (S/T)			Total Cool Cap.	Comp. Motor Input	Sensible To Total Ratio (S/T)					
				Dry Bulb					Dry Bulb					Dry Bulb					
L/s	kW	kW	24°C	27°C	29°C	kW	kW	24°C	27°C	29°C	kW	kW	24°C	27°C	29°C				
17.2°C	905	14.0	5.36	0.89	1.00	1.00	13.7	5.62	0.90	1.00	1.00	13.3	5.84	0.92	1.00	1.00			
	1135	15.0	5.37	0.98	1.00	1.00	14.7	5.64	0.99	1.00	1.00	14.2	5.84	1.00	1.00	1.00			
	1360	15.8	5.40	1.00	1.00	1.00	15.3	5.65	1.00	1.00	1.00	14.9	5.88	1.00	1.00	1.00			
19.4°C	905	14.4	5.37	0.69	0.90	1.00	14.0	5.62	0.70	0.92	1.00	13.5	5.83	0.71	0.93	1.00			
	1135	15.1	5.38	0.76	0.99	1.00	14.6	5.63	0.77	1.00	1.00	14.2	5.85	0.78	1.00	1.00			
	1360	15.8	5.40	0.82	1.00	1.00	15.4	5.65	0.83	1.00	1.00	14.9	5.86	0.84	1.00	1.00			
21.7°C	905	15.8	5.40	0.43	0.63	0.75	15.3	5.65	0.42	0.63	0.77	14.9	5.86	0.43	0.64	0.77			
	1135	16.4	5.41	0.45	0.68	0.83	15.9	5.67	0.45	0.69	0.85	15.4	5.88	0.46	0.70	0.86			
	1360	16.8	5.42	0.47	0.74	0.91	16.2	5.67	0.47	0.75	0.92	15.8	5.89	0.48	0.76	0.94			

21 kW - KHB074S4 - STANDARD EFFICIENCY - HEATING CAPACITY

Indoor Coil Air Volume 21°C Dry Bulb	Air Temperature Entering Outdoor Coil									
	18°C		7°C		-4°C		-15°C		-28°C	
	Total Heating Capacity	Comp. Motor Input	Total Heating Capacity	Comp. Motor Input	Total Heating Capacity	Comp. Motor Input	Total Heating Capacity	Comp. Motor Input	Total Heating Capacity	Comp. Motor Input
L/s	kW	kW	kW	kW	kW	kW	kW	kW	kW	kW
905	21.2	4.01	17.1	3.78	13.1	3.54	8.8	3.17	4.3	2.37
1135	21.6	3.78	17.5	3.55	13.5	3.31	9.1	2.94	4.6	2.14
1360	21.9	3.64	17.8	3.40	13.7	3.17	9.4	2.80	4.9	1.99

COOLING / HEATING RATINGS

HIGH EFFICIENCY

NOTE - For Temperatures and Capacities not shown in tables, see bulletin - Cooling Unit Rating Table Correction Factor Data in Miscellaneous Engineering Data section.

10.5 KW - KHB036H4 - HIGH EFFICIENCY - COOLING CAPACITY (1ST STAGE)

Entering Wet Bulb Temperature	Total Air Volume	Outdoor Air Temperature Entering Outdoor Coil																							
		18.3°C						23.9°C						29.4°C						35°C					
		Total Cool Cap.	Comp. Motor Input	Sensible To Total Ratio (S/T)			Total Cool Cap.	Comp. Motor Input	Sensible To Total Ratio (S/T)			Total Cool Cap.	Comp. Motor Input	Sensible To Total Ratio (S/T)			Total Cool Cap.	Comp. Motor Input	Sensible To Total Ratio (S/T)						
				Dry Bulb					Dry Bulb					Dry Bulb					Dry Bulb						
L/s	kW	kW	24°C	27°C	29°C	kW	kW	24°C	27°C	29°C	kW	kW	24°C	27°C	29°C	kW	kW	24°C	27°C	29°C					
17.2°C	302	6.2	1.08	0.73	0.89	1	5.5	1.35	0.75	0.94	1	4.8	1.69	0.78	1	1	4.1	2.1	0.85	1	1				
	378	6.6	1.07	0.79	0.99	1	5.9	1.34	0.83	1	1	5.3	1.68	0.88	1	1	4.5	2.09	0.97	1	1				
	453	7	1.06	0.86	1	1	6.4	1.33	0.91	1	1	5.6	1.67	0.98	1	1	4.8	2.09	1	1	1				
19.4°C	302	6.7	1.07	0.56	0.7	0.85	5.9	1.34	0.57	0.73	0.89	5.2	1.68	0.57	0.76	0.95	4.3	2.09	0.59	0.81	1				
	378	7	1.06	0.6	0.77	0.95	6.3	1.33	0.61	0.8	1	5.5	1.68	0.63	0.85	1	4.6	2.09	0.66	0.94	1				
	453	7.3	1.05	0.64	0.84	1	6.5	1.33	0.66	0.88	1	5.7	1.67	0.69	0.95	1	4.8	2.09	0.73	1	1				
21.7°C	302	7.1	1.06	0.42	0.55	0.68	6.4	1.33	0.41	0.56	0.7	5.6	1.68	0.39	0.57	0.73	4.7	2.09	0.38	0.59	0.78				
	378	7.5	1.05	0.43	0.59	0.75	6.8	1.32	0.43	0.6	0.77	5.9	1.67	0.42	0.62	0.82	5	2.09	0.42	0.66	0.9				
	453	7.8	1.04	0.45	0.63	0.81	7	1.32	0.45	0.65	0.85	6.2	1.67	0.45	0.68	0.91	5.2	2.08	0.45	0.73	1				

10.5 KW - KHB036H4 - HIGH EFFICIENCY - COOLING CAPACITY (2ND STAGE)

Entering Wet Bulb Temperature	Total Air Volume	Outdoor Air Temperature Entering Outdoor Coil																							
		26.7°C						35°C						43.3°C						46°C					
		Total Cool Cap.	Comp. Motor Input	Sensible To Total Ratio (S/T)			Total Cool Cap.	Comp. Motor Input	Sensible To Total Ratio (S/T)			Total Cool Cap.	Comp. Motor Input	Sensible To Total Ratio (S/T)			Total Cool Cap.	Comp. Motor Input	Sensible To Total Ratio (S/T)						
				Dry Bulb					Dry Bulb					Dry Bulb					Dry Bulb						
L/s	kW	kW	24°C	27°C	29°C	kW	kW	24°C	27°C	29°C	kW	kW	24°C	27°C	29°C	kW	kW	24°C	27°C	29°C					
17.2°C	453	9.1	1.65	0.74	0.91	1	8.1	1.96	0.76	0.95	1	7	2.36	0.79	1	1	6.7	2.50	0.81	1.00	1.00				
	566	9.6	1.67	0.81	1	1	8.7	1.97	0.84	1	1	7.7	2.37	0.88	1	1	7.3	2.51	0.91	1.00	1.00				
	680	10.2	1.68	0.87	1	1	9.2	1.98	0.92	1	1	8.1	2.37	0.98	1	1	7.7	2.52	0.99	1.00	1.00				
19.4°C	453	9.7	1.67	0.57	0.72	0.87	8.7	1.97	0.57	0.74	0.91	7.6	2.36	0.57	0.77	0.96	7.2	2.51	0.58	0.79	0.99				
	566	10.2	1.68	0.61	0.79	0.97	9.1	1.98	0.62	0.81	1	7.9	2.37	0.63	0.86	1	7.5	2.52	0.64	0.89	1.00				
	680	10.6	1.69	0.65	0.85	1	9.5	1.99	0.66	0.9	1	8.2	2.38	0.69	0.96	1	7.8	2.52	0.71	0.98	1.00				
21.7°C	453	10.4	1.68	0.42	0.56	0.7	9.3	1.98	0.4	0.56	0.72	8.1	2.37	0.39	0.57	0.74	7.7	2.52	0.38	0.58	0.77				
	566	10.9	1.7	0.44	0.61	0.77	9.7	1.99	0.43	0.61	0.79	8.5	2.38	0.42	0.63	0.84	8.1	2.52	0.41	0.64	0.87				
	680	11.2	1.71	0.46	0.65	0.83	10.1	2	0.45	0.66	0.87	8.8	2.38	0.44	0.69	0.93	8.4	2.52	0.45	0.71	0.96				

Entering Wet Bulb Temperature	Total Air Volume	Outdoor Air Temperature Entering Outdoor Coil																	
		48°C						50°C						51.7°C					
		Total Cool Cap.	Comp. Motor Input	Sensible To Total Ratio (S/T)			Total Cool Cap.	Comp. Motor Input	Sensible To Total Ratio (S/T)			Total Cool Cap.	Comp. Motor Input	Sensible To Total Ratio (S/T)					
				Dry Bulb					Dry Bulb					Dry Bulb					
L/s	kW	kW	24°C	27°C	29°C	kW	kW	24°C	27°C	29°C	kW	kW	24°C	27°C	29°C				
17.2°C	455	6.4	2.62	0.83	1.00	1.00	6.2	2.75	0.84	1.00	1.00	5.9	2.85	0.84	1	1			
	565	7.0	2.63	0.93	1.00	1.00	6.7	2.75	0.95	1.00	1.00	6.5	2.86	0.96	1	1			
	680	7.4	2.63	1.00	1.00	1.00	7.2	2.75	1.00	1.00	1.00	6.9	2.86	1	1	1			
19.4°C	455	6.8	2.63	0.58	0.80	1.00	6.5	2.75	0.59	0.82	1.00	6.2	2.86	0.58	0.82	1			
	565	7.2	2.63	0.65	0.90	1.00	6.9	2.75	0.66	0.93	1.00	6.6	2.86	0.66	0.94	1			
	680	7.5	2.63	0.72	0.99	1.00	7.2	2.76	0.73	1.00	1.00	6.9	2.86	0.73	1	1			
21.7°C	455	7.4	2.63	0.38	0.58	0.78	7.1	2.76	0.37	0.58	0.79	6.8	2.87	0.36	0.58	0.79			
	565	7.8	2.64	0.41	0.65	0.88	7.4	2.76	0.41	0.66	0.90	7.1	2.87	0.4	0.66	0.91			
	680	8.0	2.64	0.44	0.72	0.98	7.6	2.76	0.44	0.73	0.99	7.3	2.87	0.44	0.73	1			

10.5 KW - KHB036H4 - HEATING CAPACITY

Indoor Coil Air Volume 21°C Dry Bulb	Air Temperature Entering Outdoor Coil									
	18°C		7°C		-4°C		-15°C		-28°C	
	Total Heating Capacity	Comp. Motor Input	Total Heating Capacity	Comp. Motor Input	Total Heating Capacity	Comp. Motor Input	Total Heating Capacity	Comp. Motor Input	Total Heating Capacity	Comp. Motor Input
L/s	kW	kW	kW	kW	kW	kW	kW	kW	kW	kW
455	11.1	2.04	8.3	1.91	5.3	1.78	3.3	1.58	1.7	1.18
565	11.3	1.93	8.4	1.80	5.5	1.67	3.5	1.47	1.9	1.07
680	11.5	1.86	8.6	1.73	5.6	1.60	3.6	1.41	2.0	1.01

COOLING / HEATING RATINGS

HIGH EFFICIENCY

NOTE - For Temperatures and Capacities not shown in tables, see bulletin - Cooling Unit Rating Table Correction Factor Data in Miscellaneous Engineering Data section.

14 KW - KHB048H4 - HIGH EFFICIENCY - COOLING CAPACITY (1ST STAGE)

Entering Wet Bulb Temperature	Total Air Volume	Outdoor Air Temperature Entering Outdoor Coil																			
		18.3°C					23.9°C					29.4°C					35°C				
		Total Cool Cap.	Comp. Motor Input	Sensible To Total Ratio (S/T)			Total Cool Cap.	Comp. Motor Input	Sensible To Total Ratio (S/T)			Total Cool Cap.	Comp. Motor Input	Sensible To Total Ratio (S/T)			Total Cool Cap.	Comp. Motor Input	Sensible To Total Ratio (S/T)		
				Dry Bulb					Dry Bulb					Dry Bulb					Dry Bulb		
L/s	kW	kW	24°C	27°C	29°C	kW	kW	24°C	27°C	29°C	kW	kW	24°C	27°C	29°C	kW	kW	24°C	27°C	29°C	
17.2°C	422	9.3	1.13	0.74	0.88	1	8.8	1.34	0.75	0.9	1	8.2	1.58	0.76	0.93	1	7.6	1.84	0.78	0.96	1
	529	9.8	1.11	0.8	0.96	1	9.3	1.33	0.81	0.98	1	8.8	1.56	0.82	1	1	8.2	1.83	0.85	1	1
	635	10.3	1.1	0.85	1	1	9.9	1.31	0.87	1	1	9.3	1.55	0.9	1	1	8.8	1.81	0.93	1	1
19.4°C	422	9.9	1.11	0.58	0.72	0.84	9.4	1.32	0.58	0.73	0.86	8.8	1.56	0.59	0.74	0.89	8.2	1.83	0.59	0.76	0.92
	529	10.5	1.09	0.62	0.77	0.93	9.9	1.31	0.62	0.79	0.95	9.3	1.55	0.63	0.8	0.98	8.6	1.82	0.64	0.83	1
	635	10.9	1.08	0.65	0.83	0.99	10.3	1.3	0.66	0.85	1	9.7	1.54	0.67	0.87	1	9	1.81	0.68	0.9	1
21.7°C	422	10.5	1.09	0.43	0.57	0.69	10	1.31	0.43	0.57	0.7	9.4	1.55	0.43	0.57	0.71	8.8	1.81	0.43	0.58	0.73
	529	11.1	1.07	0.45	0.61	0.75	10.6	1.29	0.44	0.61	0.77	9.9	1.53	0.45	0.62	0.78	9.2	1.8	0.44	0.63	0.81
	635	11.6	1.06	0.47	0.64	0.81	11	1.28	0.47	0.65	0.83	10.3	1.53	0.46	0.66	0.85	9.6	1.79	0.47	0.68	0.88

14 KW - KHB048H4 - HIGH EFFICIENCY - COOLING CAPACITY (2ND STAGE)

Entering Wet Bulb Temperature	Total Air Volume	Outdoor Air Temperature Entering Outdoor Coil																			
		26.7°C					35°C					43.3°C					46°C				
		Total Cool Cap.	Comp. Motor Input	Sensible To Total Ratio (S/T)			Total Cool Cap.	Comp. Motor Input	Sensible To Total Ratio (S/T)			Total Cool Cap.	Comp. Motor Input	Sensible To Total Ratio (S/T)			Total Cool Cap.	Comp. Motor Input	Sensible To Total Ratio (S/T)		
				Dry Bulb					Dry Bulb					Dry Bulb					Dry Bulb		
L/s	kW	kW	24°C	27°C	29°C	kW	kW	24°C	27°C	29°C	kW	kW	24°C	27°C	29°C	kW	kW	24°C	27°C	29°C	
17.2°C	604	12.2	2.12	0.78	0.93	1	10.8	2.54	0.8	0.96	1	9.4	3.07	0.83	1	1	9.0	3.27	0.82	1.00	1.00
	755	12.9	2.13	0.85	1	1	11.6	2.55	0.88	1	1	10.2	3.09	0.92	1	1	9.8	3.29	0.92	1.00	1.00
	906	13.6	2.14	0.91	1	1	12.3	2.56	0.94	1	1	10.8	3.1	0.99	1	1	10.3	3.30	1.00	1.00	1.00
19.4°C	604	13	2.13	0.6	0.76	0.9	11.6	2.55	0.6	0.78	0.93	10.1	3.08	0.61	0.81	0.98	9.6	3.28	0.59	0.80	0.99
	755	13.6	2.14	0.65	0.83	0.97	12.1	2.56	0.66	0.86	1	10.6	3.1	0.68	0.9	1	10.0	3.29	0.66	0.90	1.00
	906	14.1	2.14	0.69	0.89	1	12.5	2.56	0.71	0.93	1	10.9	3.1	0.74	0.98	1	10.4	3.30	0.72	0.99	1.00
21.7°C	604	13.7	2.14	0.44	0.59	0.74	12.3	2.56	0.43	0.6	0.76	10.8	3.1	0.41	0.61	0.79	10.2	3.30	0.39	0.59	0.78
	755	14.4	2.14	0.47	0.64	0.81	12.9	2.57	0.45	0.65	0.84	11.2	3.11	0.45	0.67	0.89	10.7	3.31	0.42	0.66	0.88
	906	14.9	2.15	0.48	0.69	0.88	13.3	2.58	0.48	0.71	0.91	11.6	3.12	0.48	0.74	0.96	11.0	3.32	0.45	0.72	0.98

Entering Wet Bulb Temperature	Total Air Volume	Outdoor Air Temperature Entering Outdoor Coil														
		48°C					50°C					51.7°C				
		Total Cool Cap.	Comp. Motor Input	Sensible To Total Ratio (S/T)			Total Cool Cap.	Comp. Motor Input	Sensible To Total Ratio (S/T)			Total Cool Cap.	Comp. Motor Input	Sensible To Total Ratio (S/T)		
				Dry Bulb					Dry Bulb					Dry Bulb		
L/s	kW	kW	24°C	27°C	29°C	kW	kW	24°C	27°C	29°C	kW	kW	24°C	27°C	29°C	
17.2°C	605	8.7	3.43	0.83	1.00	1.00	8.4	3.60	0.84	1.00	1.00	8.1	3.75	0.88	1	1
	755	9.4	3.45	0.94	1.00	1.00	9.1	3.62	0.96	1.00	1.00	8.7	3.78	0.98	1	1
	905	10.0	3.46	1.00	1.00	1.00	9.6	3.64	1.00	1.00	1.00	9.3	3.79	1	1	1
19.4°C	605	9.1	3.44	0.60	0.81	1.00	8.8	3.61	0.60	0.82	1.00	8.4	3.77	0.62	0.86	1
	755	9.6	3.46	0.66	0.92	1.00	9.2	3.62	0.67	0.94	1.00	8.9	3.78	0.7	0.96	1
	905	10.0	3.47	0.73	1.00	1.00	9.6	3.64	0.74	1.00	1.00	9.3	3.79	0.78	1	1
21.7°C	605	9.8	3.45	0.39	0.59	0.79	9.4	3.62	0.38	0.60	0.80	9.1	3.78	0.39	0.62	0.84
	755	10.2	3.46	0.42	0.66	0.90	9.8	3.64	0.42	0.67	0.92	9.5	3.8	0.43	0.7	0.95
	905	10.6	3.48	0.46	0.73	0.99	10.2	3.65	0.46	0.75	1.00	9.8	3.81	0.47	0.78	1

14 KW - KHB048H4 - HEATING CAPACITY

Indoor Coil Air Volume 21°C Dry Bulb	Air Temperature Entering Outdoor Coil									
	18°C		7°C		-4°C		-15°C		-28°C	
	Total Heating Capacity	Comp. Motor Input	Total Heating Capacity	Comp. Motor Input	Total Heating Capacity	Comp. Motor Input	Total Heating Capacity	Comp. Motor Input	Total Heating Capacity	Comp. Motor Input
L/s	kW	kW	kW	kW	kW	kW	kW	kW	kW	kW
605	14.5	2.51	10.8	2.35	6.9	2.19	4.4	1.94	2.2	1.45
755	14.8	2.38	11.1	2.22	7.2	2.07	4.7	1.81	2.5	1.32
905	15.0	2.30	11.3	2.14	7.4	1.99	4.9	1.73	2.7	1.24

COOLING / HEATING RATINGS

HIGH EFFICIENCY

NOTE - For Temperatures and Capacities not shown in tables, see bulletin - Cooling Unit Rating Table Correction Factor Data in Miscellaneous Engineering Data section.

17.5 KW - KHB060H4 - HIGH EFFICIENCY - COOLING CAPACITY (1ST STAGE)

Entering Wet Bulb Temperature	Total Air Volume	Outdoor Air Temperature Entering Outdoor Coil																							
		18.3°C						23.9°C						29.4°C						35°C					
		Total Cool Cap.	Comp. Motor Input	Sensible To Total Ratio (S/T)			Total Cool Cap.	Comp. Motor Input	Sensible To Total Ratio (S/T)			Total Cool Cap.	Comp. Motor Input	Sensible To Total Ratio (S/T)			Total Cool Cap.	Comp. Motor Input	Sensible To Total Ratio (S/T)						
				Dry Bulb					Dry Bulb					Dry Bulb					Dry Bulb						
L/s	kW	kW	24°C	27°C	29°C	kW	kW	24°C	27°C	29°C	kW	kW	24°C	27°C	29°C	kW	kW	24°C	27°C	29°C					
17.2°C	510	12	1.46	0.73	0.87	1	11.5	1.7	0.74	0.89	1	11	1.99	0.76	0.91	1	10.4	2.31	0.78	0.95	1				
	637	12.6	1.44	0.78	0.95	1	12.2	1.69	0.79	0.97	1	11.6	1.98	0.82	1	1	11.1	2.29	0.85	1	1				
	765	13.2	1.42	0.83	1	1	12.8	1.67	0.85	1	1	12.3	1.96	0.88	1	1	11.7	2.28	0.92	1	1				
19.4°C	510	12.7	1.43	0.57	0.7	0.83	12.3	1.68	0.58	0.71	0.85	11.8	1.97	0.6	0.73	0.87	11.1	2.3	0.61	0.75	0.9				
	637	13.4	1.42	0.61	0.76	0.91	12.9	1.67	0.62	0.77	0.93	12.3	1.96	0.62	0.79	0.96	11.6	2.28	0.65	0.82	0.99				
	765	13.8	1.4	0.64	0.81	0.98	13.3	1.66	0.65	0.83	1	12.7	1.95	0.66	0.85	1	12	2.27	0.68	0.89	1				
21.7°C	510	13.5	1.41	0.43	0.56	0.67	13.1	1.67	0.44	0.56	0.69	12.5	1.95	0.44	0.58	0.7	11.9	2.28	0.45	0.59	0.73				
	637	14.2	1.39	0.45	0.59	0.73	13.7	1.65	0.45	0.6	0.75	13.1	1.94	0.46	0.61	0.76	12.4	2.26	0.47	0.63	0.79				
	765	14.7	1.38	0.46	0.62	0.78	14.1	1.64	0.47	0.64	0.8	13.5	1.93	0.47	0.65	0.83	12.7	2.25	0.48	0.67	0.86				

17.5 KW - KHB060H4 - HIGH EFFICIENCY - COOLING CAPACITY (2ND STAGE)

Entering Wet Bulb Temperature	Total Air Volume	Outdoor Air Temperature Entering Outdoor Coil																							
		26.7°C						35°C						43.3°C						46°C					
		Total Cool Cap.	Comp. Motor Input	Sensible To Total Ratio (S/T)			Total Cool Cap.	Comp. Motor Input	Sensible To Total Ratio (S/T)			Total Cool Cap.	Comp. Motor Input	Sensible To Total Ratio (S/T)			Total Cool Cap.	Comp. Motor Input	Sensible To Total Ratio (S/T)						
				Dry Bulb					Dry Bulb					Dry Bulb					Dry Bulb						
L/s	kW	kW	24°C	27°C	29°C	kW	kW	24°C	27°C	29°C	kW	kW	24°C	27°C	29°C	kW	kW	24°C	27°C	29°C					
17.2°C	755	15.7	2.7	0.74	0.91	1	14.1	3.2	0.76	0.95	1	12.3	3.82	0.79	1	1	11.8	4.05	0.81	1.00	1.00				
	944	16.6	2.73	0.81	1	1	15.1	3.22	0.84	1	1	13.5	3.86	0.88	1	1	12.9	4.09	0.92	1.00	1.00				
	1133	17.7	2.75	0.88	1	1	16.1	3.25	0.92	1	1	14.3	3.88	0.98	1	1	13.7	4.11	1.00	1.00	1.00				
19.4°C	755	16.9	2.73	0.57	0.72	0.87	15.2	3.23	0.57	0.73	0.91	13.3	3.85	0.58	0.76	0.96	12.7	4.08	0.58	0.79	0.98				
	944	17.8	2.76	0.61	0.79	0.97	15.9	3.25	0.61	0.81	1	14	3.87	0.63	0.85	1	13.3	4.10	0.65	0.89	1.00				
	1133	18.4	2.77	0.65	0.85	1	16.5	3.26	0.66	0.89	1	14.5	3.89	0.68	0.95	1	13.8	4.11	0.70	0.98	1.00				
21.7°C	755	18.1	2.76	0.41	0.56	0.69	16.4	3.26	0.4	0.56	0.71	14.4	3.88	0.39	0.57	0.74	13.8	4.11	0.39	0.58	0.76				
	944	19	2.79	0.44	0.6	0.76	17.1	3.28	0.43	0.61	0.79	15.1	3.91	0.42	0.63	0.83	14.4	4.13	0.42	0.64	0.85				
	1133	19.6	2.81	0.46	0.65	0.83	17.7	3.29	0.45	0.66	0.87	15.6	3.92	0.44	0.68	0.92	14.9	4.14	0.44	0.70	0.95				

Entering Wet Bulb Temperature	Total Air Volume	Outdoor Air Temperature Entering Outdoor Coil																	
		48°C						50°C						51.7°C					
		Total Cool Cap.	Comp. Motor Input	Sensible To Total Ratio (S/T)			Total Cool Cap.	Comp. Motor Input	Sensible To Total Ratio (S/T)			Total Cool Cap.	Comp. Motor Input	Sensible To Total Ratio (S/T)					
				Dry Bulb					Dry Bulb					Dry Bulb					
L/s	kW	kW	24°C	27°C	29°C	kW	kW	24°C	27°C	29°C	kW	kW	24°C	27°C	29°C				
17.2°C	755	11.3	4.23	0.82	1.00	1.00	10.9	4.43	0.83	1.00	1.00	10.6	4.6	0.84	1	1			
	945	12.4	4.27	0.93	1.00	1.00	12.0	4.46	0.94	1.00	1.00	11.5	4.63	0.96	1	1			
	1135	13.2	4.30	1.00	1.00	1.00	12.7	4.49	1.00	1.00	1.00	12.3	4.66	1	1	1			
19.4°C	755	12.2	4.26	0.58	0.80	1.00	11.6	4.45	0.58	0.81	1.00	11.2	4.63	0.58	0.8	1			
	945	12.8	4.28	0.65	0.90	1.00	12.2	4.47	0.66	0.92	1.00	11.8	4.63	0.66	0.93	1			
	1135	13.3	4.29	0.72	0.99	1.00	12.7	4.49	0.73	1.00	1.00	12.3	4.66	0.72	1	1			
21.7°C	755	13.2	4.29	0.38	0.58	0.77	12.7	4.49	0.38	0.58	0.79	12.3	4.65	0.37	0.58	0.78			
	945	13.9	4.31	0.41	0.65	0.87	13.3	4.50	0.41	0.65	0.89	12.8	4.67	0.41	0.65	0.9			
	1135	14.3	4.32	0.44	0.71	0.97	13.8	4.52	0.45	0.72	0.99	13.2	4.69	0.45	0.72	1			

17.5 KW - KHB060H4 - HEATING CAPACITY

Indoor Coil Air Volume 21°C Dry Bulb	Air Temperature Entering Outdoor Coil									
	18°C		7°C		-4°C		-15°C		-28°C	
	Total Heating Capacity	Comp. Motor Input	Total Heating Capacity	Comp. Motor Input	Total Heating Capacity	Comp. Motor Input	Total Heating Capacity	Comp. Motor Input	Total Heating Capacity	Comp. Motor Input
L/s	kW	kW	kW	kW	kW	kW	kW	kW	kW	kW
755	18.6	3.16	14.1	3.00	9.5	2.84	5.8	2.58	2.9	1.91
945	18.9	2.98	14.4	2.83	9.8	2.67	6.1	2.40	3.2	1.74
1135	19.1	2.88	14.6	2.72	10.0	2.56	6.3	2.30	3.5	1.63

BLOWER DATA

BELT DRIVE | 3 TON

BLOWER TABLE INCLUDES RESISTANCE FOR BASE UNIT ONLY WITH DRY INDOOR COIL AND AIR FILTERS IN PLACE.

FOR ALL UNITS ADD:

- 1 - Any factory installed options air resistance (heat section, economizer, etc.).
- 2 - Any field installed accessories air resistance (duct resistance, diffuser, etc.).

See page 31 for blower motors and drives and wet coil and options/accessory air resistance data.

DOWNFLOW

Air Volume		External Static - Pa (in.w.g.)																							
		25 (0.10)		50 (0.20)		75 (0.30)		100 (0.40)		125 (0.50)		150 (0.60)		175 (0.70)		200 (0.80)									
L/s	cfm	Rev/min	kW	BHP	Rev/min	kW	BHP	Rev/min	kW	BHP	Rev/min	kW	BHP	Rev/min	kW	BHP	Rev/min	kW	BHP						
330	700	447	0.07	0.09	517	0.09	0.12	589	0.11	0.15	663	0.13	0.17	739	0.14	0.19	815	0.15	0.2	883	0.17	0.23	938	0.19	0.25
380	800	465	0.07	0.1	534	0.10	0.14	605	0.13	0.17	678	0.14	0.19	753	0.16	0.21	825	0.17	0.23	890	0.19	0.25	946	0.20	0.27
425	900	486	0.09	0.12	554	0.12	0.16	623	0.15	0.2	695	0.16	0.22	767	0.17	0.23	836	0.19	0.25	897	0.21	0.28	953	0.22	0.3
470	1000	508	0.11	0.15	576	0.14	0.19	643	0.16	0.22	713	0.18	0.24	783	0.19	0.26	848	0.21	0.28	907	0.22	0.3	961	0.25	0.33
520	1100	533	0.13	0.18	599	0.16	0.22	665	0.19	0.25	733	0.20	0.27	800	0.21	0.28	863	0.23	0.31	919	0.25	0.34	971	0.27	0.36
565	1200	560	0.16	0.21	625	0.19	0.25	689	0.21	0.28	755	0.22	0.3	820	0.24	0.32	879	0.25	0.34	932	0.28	0.37	983	0.30	0.4
615	1300	591	0.18	0.24	654	0.21	0.28	716	0.23	0.31	779	0.25	0.33	841	0.26	0.35	897	0.28	0.38	948	0.31	0.41	996	0.33	0.44
660	1400	631	0.19	0.26	690	0.22	0.3	748	0.25	0.34	807	0.27	0.36	864	0.29	0.39	916	0.31	0.42	964	0.34	0.46	1011	0.37	0.49
710	1500	676	0.21	0.28	729	0.25	0.33	782	0.27	0.36	835	0.30	0.4	887	0.32	0.43	935	0.35	0.47	981	0.37	0.5	1028	0.40	0.54

Air Volume		External Static - Pa (in.w.g.)																							
		225 (0.90)		250 (1.00)		275 (1.10)		300 (1.20)		325 (1.30)		350 (1.40)		375 (1.50)		400 (1.60)									
L/s	cfm	Rev/min	kW	BHP	Rev/min	kW	BHP	Rev/min	kW	BHP	Rev/min	kW	BHP	Rev/min	kW	BHP	Rev/min	kW	BHP						
330	700	988	0.20	0.27	1039	0.22	0.29	1088	0.23	0.31	1144	0.27	0.36	1185	0.29	0.39	1224	0.31	0.42	1269	0.37	0.49	1305	0.39	0.52
380	800	996	0.22	0.3	1047	0.24	0.32	1098	0.25	0.34	1152	0.30	0.4	1193	0.32	0.43	1232	0.34	0.46	1276	0.40	0.53	1311	0.42	0.56
425	900	1004	0.25	0.33	1055	0.26	0.35	1106	0.28	0.37	1163	0.35	0.47	1206	0.38	0.51	1245	0.40	0.54	1289	0.46	0.62	1324	0.49	0.66
470	1000	1011	0.27	0.36	1062	0.28	0.38	1111	0.31	0.41	1171	0.39	0.52	1213	0.41	0.55	1252	0.44	0.59	1296	0.51	0.68	1330	0.53	0.71
520	1100	1020	0.29	0.39	1070	0.31	0.41	1118	0.33	0.44	1181	0.42	0.56	1221	0.45	0.6	1259	0.48	0.64	1296	0.51	0.68	1337	0.57	0.77
565	1200	1031	0.32	0.43	1079	0.34	0.45	1127	0.36	0.48	1191	0.46	0.61	1231	0.48	0.65	1268	0.51	0.69	1303	0.54	0.73	1345	0.61	0.82
615	1300	1044	0.35	0.47	1091	0.37	0.49	1137	0.40	0.53	1203	0.50	0.67	1241	0.53	0.71	1277	0.56	0.75	1312	0.59	0.79	1354	0.67	0.91
660	1400	1058	0.38	0.51	1105	0.40	0.54	1150	0.43	0.57	1217	0.53	0.72	1256	0.56	0.76	1293	0.6	0.81	1331	0.64	0.86	1374	0.71	0.98
710	1500	1074	0.42	0.56	1120	0.44	0.59	1163	0.47	0.63	1231	0.57	0.77	1270	0.61	0.82	1307	0.65	0.87	1346	0.7	0.94	1390	0.77	1.04

BLOWER DATA

BELT DRIVE | 3 TON

BLOWER TABLE INCLUDES RESISTANCE FOR BASE UNIT ONLY WITH DRY INDOOR COIL AND AIR FILTERS IN PLACE.

FOR ALL UNITS ADD:

1 - Any factory installed options air resistance (heat section, economizer, etc.).

2 - Any field installed accessories air resistance (duct resistance, diffuser, etc.).

See page 31 for blower motors and drives and wet coil and options/accessory air resistance data.

HORIZONTAL

Air Volume		External Static - Pa (in.w.g.)																				
		25 (0.10)		50 (0.20)		75 (0.30)		100 (0.40)		125 (0.50)		150 (0.60)		175 (0.70)		200 (0.80)						
L/s	cfm	Rev/min	kW	BHP	Rev/min	kW	BHP	Rev/min	kW	BHP	Rev/min	kW	BHP	Rev/min	kW	BHP	Rev/min	kW	BHP			
330	700	445	0.06	0.08	516	0.08	0.11	0.13	670	0.11	0.15	0.12	0.16	820	0.14	0.19	870	0.16	0.22	918	0.18	0.24
380	800	463	0.07	0.09	534	0.09	0.12	0.14	685	0.12	0.16	0.13	0.18	830	0.16	0.21	878	0.18	0.24	926	0.20	0.27
425	900	485	0.08	0.11	554	0.10	0.14	0.16	703	0.13	0.18	0.16	0.21	841	0.17	0.23	888	0.20	0.27	935	0.22	0.30
470	1000	509	0.10	0.13	578	0.12	0.16	0.19	722	0.16	0.21	0.17	0.23	854	0.19	0.26	900	0.22	0.29	947	0.25	0.33
520	1100	537	0.12	0.16	605	0.14	0.19	0.21	744	0.18	0.24	0.19	0.26	868	0.22	0.29	913	0.25	0.33	959	0.27	0.36
565	1200	567	0.14	0.19	633	0.16	0.22	0.24	768	0.20	0.27	0.22	0.30	884	0.25	0.33	928	0.28	0.37	974	0.30	0.40
615	1300	599	0.16	0.22	664	0.19	0.25	0.28	793	0.22	0.30	0.25	0.33	902	0.28	0.37	945	0.31	0.41	990	0.33	0.44
660	1400	634	0.19	0.26	697	0.22	0.29	0.31	819	0.25	0.34	0.28	0.38	921	0.31	0.42	964	0.34	0.46	1008	0.37	0.49
710	1500	669	0.22	0.30	730	0.25	0.33	0.36	846	0.29	0.39	0.31	0.42	941	0.35	0.47	983	0.38	0.51	1028	0.40	0.54

External Static - Pa (in.w.g.)

Air Volume		External Static - Pa (in.w.g.)																							
		225 (0.90)		250 (1.00)		275 (1.10)		300 (1.20)		325 (1.30)		350 (1.40)		375 (1.50)		400 (1.60)									
L/s	cfm	Rev/min	kW	BHP	Rev/min	kW	BHP	Rev/min	kW	BHP	Rev/min	kW	BHP	Rev/min	kW	BHP	Rev/min	kW	BHP						
330	700	969	0.20	0.27	1021	0.22	0.29	1071	0.24	0.32	1128	0.28	0.37	1169	0.30	0.40	1205	0.31	0.42	1248	0.37	0.49	1280	0.38	0.51
380	800	977	0.22	0.29	1030	0.24	0.32	1082	0.25	0.34	1137	0.30	0.40	1177	0.32	0.43	1214	0.34	0.46	1248	0.37	0.49	1280	0.38	0.51
425	900	986	0.24	0.32	1039	0.26	0.35	1090	0.28	0.37	1144	0.33	0.44	1184	0.35	0.47	1221	0.37	0.50	1255	0.40	0.53	1287	0.42	0.56
470	1000	997	0.26	0.35	1048	0.28	0.38	1098	0.31	0.41	1150	0.35	0.47	1191	0.38	0.51	1228	0.40	0.54	1263	0.43	0.57	1295	0.45	0.60
520	1100	1008	0.29	0.39	1059	0.31	0.41	1107	0.33	0.44	1160	0.39	0.52	1200	0.41	0.55	1237	0.44	0.59	1271	0.46	0.62	1303	0.49	0.66
565	1200	1022	0.32	0.43	1071	0.34	0.45	1117	0.36	0.48	1171	0.43	0.57	1210	0.45	0.60	1246	0.48	0.64	1280	0.51	0.68	1312	0.53	0.71
615	1300	1037	0.35	0.47	1058	0.37	0.50	1130	0.40	0.53	1183	0.46	0.62	1221	0.49	0.66	1256	0.52	0.70	1290	0.54	0.73	1321	0.57	0.77
660	1400	1054	0.39	0.52	1100	0.40	0.54	1144	0.43	0.58	1197	0.50	0.67	1234	0.53	0.71	1268	0.56	0.75	1301	0.59	0.79	1332	0.62	0.83
710	1500	1073	0.43	0.57	1117	0.45	0.60	1159	0.48	0.64	1197	0.50	0.67	1234	0.53	0.71	1268	0.56	0.75	1301	0.59	0.79	1332	0.62	0.83

BLOWER DATA

BELT DRIVE | 4 TON

BLOWER TABLE INCLUDES RESISTANCE FOR BASE UNIT ONLY WITH DRY INDOOR COIL AND AIR FILTERS IN PLACE.

FOR ALL UNITS ADD:

1 - Any factory installed options air resistance (heat section, economizer, etc.).

2 - Any field installed accessories air resistance (duct resistance, diffuser, etc.).

See page 31 for blower motors and drives and wet coil and options/accessory air resistance data.

DOWNFLOW

Air Volume		External Static - Pa (in.w.g.)																							
		25 (0.10)		50 (0.20)		75 (0.30)		100 (0.40)		125 (0.50)		150 (0.60)		175 (0.70)		200 (0.80)									
L/s	cfm	Rev/ min	BHP	Rev/ min	BHP	Rev/ min	BHP	Rev/ min	BHP	Rev/ min	BHP	Rev/ min	BHP	Rev/ min	BHP	Rev/ min	BHP								
425	900	466	0.07	0.10	525	0.10	0.14	586	0.13	0.17	646	0.15	0.20	729	0.15	0.20	821	0.14	0.19	899	0.15	0.20	953	0.17	0.23
470	1000	484	0.09	0.12	543	0.12	0.16	603	0.14	0.19	664	0.16	0.22	745	0.17	0.23	834	0.17	0.23	908	0.18	0.24	959	0.19	0.26
520	1100	505	0.11	0.15	563	0.13	0.18	622	0.16	0.22	682	0.19	0.25	762	0.19	0.26	847	0.19	0.26	917	0.20	0.27	966	0.22	0.30
565	1200	527	0.13	0.18	584	0.16	0.21	643	0.19	0.25	702	0.21	0.28	779	0.22	0.30	860	0.22	0.30	927	0.23	0.31	973	0.25	0.34
615	1300	550	0.16	0.21	607	0.19	0.25	664	0.22	0.29	722	0.24	0.32	797	0.25	0.33	875	0.25	0.34	937	0.26	0.35	981	0.28	0.38
660	1400	574	0.19	0.25	630	0.22	0.29	687	0.24	0.32	744	0.26	0.35	817	0.28	0.37	890	0.28	0.38	949	0.29	0.39	991	0.31	0.42
710	1500	603	0.21	0.28	659	0.24	0.32	714	0.27	0.36	770	0.29	0.39	839	0.31	0.41	907	0.31	0.42	962	0.33	0.44	1002	0.35	0.47
755	1600	651	0.22	0.29	703	0.25	0.33	754	0.28	0.37	806	0.31	0.41	867	0.32	0.43	927	0.34	0.45	976	0.36	0.48	1014	0.38	0.51
800	1700	708	0.22	0.30	754	0.25	0.34	800	0.28	0.38	846	0.31	0.42	898	0.34	0.46	949	0.37	0.49	992	0.40	0.53	1028	0.43	0.57
850	1800	764	0.23	0.31	804	0.27	0.36	844	0.30	0.40	884	0.34	0.45	927	0.37	0.49	970	0.40	0.54	1008	0.43	0.58	1044	0.47	0.63
900	1900	812	0.25	0.34	847	0.29	0.39	881	0.33	0.44	916	0.37	0.49	953	0.40	0.54	990	0.44	0.59	1025	0.48	0.64	1061	0.51	0.69
945	2000	857	0.31	0.42	889	0.35	0.47	920	0.39	0.52	952	0.43	0.57	986	0.46	0.62	1020	0.51	0.68	1055	0.54	0.73	1091	0.57	0.77

Air Volume		External Static - Pa (in.w.g.)																							
		225 (0.90)		250 (1.00)		275 (1.10)		300 (1.20)		325 (1.30)		350 (1.40)		375 (1.50)		400 (1.60)									
L/s	cfm	Rev/ min	BHP	Rev/ min	BHP	Rev/ min	BHP	Rev/ min	BHP	Rev/ min	BHP	Rev/ min	BHP	Rev/ min	BHP	Rev/ min	BHP								
425	900	---	---	---	---	---	---	---	---	---	---	---	---	---	---	---	---								
470	1000	996	0.23	0.31	1034	0.26	0.35	1083	0.31	0.42	1128	0.34	0.46	1176	0.37	0.49	1224	0.42	0.56	1261	0.45	0.60	1295	0.50	0.67
520	1100	1001	0.25	0.34	1040	0.28	0.38	1089	0.34	0.46	1133	0.37	0.49	1180	0.40	0.53	1224	0.42	0.56	1264	0.47	0.63	1300	0.53	0.71
565	1200	1008	0.28	0.38	1047	0.31	0.42	1097	0.37	0.50	1139	0.40	0.53	1184	0.43	0.57	1228	0.45	0.60	1264	0.47	0.63	1305	0.57	0.76
615	1300	1017	0.31	0.42	1055	0.34	0.46	1106	0.40	0.54	1147	0.43	0.57	1191	0.46	0.61	1233	0.48	0.64	1269	0.51	0.68	1300	0.57	0.76
660	1400	1026	0.34	0.46	1065	0.37	0.50	1117	0.44	0.59	1157	0.46	0.62	1199	0.48	0.65	1240	0.51	0.69	1275	0.54	0.72	1305	0.57	0.76
710	1500	1038	0.38	0.51	1076	0.41	0.55	1129	0.48	0.64	1168	0.50	0.67	1209	0.53	0.71	1249	0.55	0.74	1282	0.58	0.78	1312	0.61	0.82
755	1600	1050	0.42	0.56	1089	0.45	0.60	1142	0.51	0.69	1181	0.54	0.73	1221	0.57	0.76	1259	0.60	0.80	1292	0.62	0.83	1320	0.66	0.88
800	1700	1065	0.46	0.61	1103	0.48	0.65	1156	0.56	0.75	1194	0.59	0.79	1234	0.61	0.82	1271	0.64	0.86	1302	0.67	0.90	1330	0.70	0.94
850	1800	1081	0.50	0.67	1118	0.53	0.71	1172	0.60	0.81	1209	0.63	0.85	1248	0.66	0.88	1284	0.69	0.92	1314	0.72	0.97	1341	0.75	1.01
900	1900	1098	0.54	0.73	1135	0.57	0.77	1194	0.66	0.89	1239	0.69	0.93	1276	0.72	0.97	1310	0.75	1.01	1336	0.79	1.06	1362	0.82	1.10
945	2000	1128	0.61	0.82	1164	0.64	0.86	1201	0.66	0.89	1239	0.69	0.93	1276	0.72	0.97	1310	0.75	1.01	1336	0.79	1.06	1362	0.82	1.10

BLOWER DATA

BELT DRIVE | 4 TON

BLOWER TABLE INCLUDES RESISTANCE FOR BASE UNIT ONLY WITH DRY INDOOR COIL AND AIR FILTERS IN PLACE.

FOR ALL UNITS ADD:

1 - Any factory installed options air resistance (heat section, economizer, etc.).

2 - Any field installed accessories air resistance (duct resistance, diffuser, etc.).

See page 31 for blower motors and drives and wet coil and options/accessory air resistance data.

HORIZONTAL

Air Volume		External Static - Pa (in.w.g.)															
		25 (0.10)		50 (0.20)		75 (0.30)		100 (0.40)		125 (0.50)		150 (0.60)		175 (0.70)		200 (0.80)	
L/s	cfm	Rev/min	BHP	Rev/min	BHP	Rev/min	BHP	Rev/min	BHP	Rev/min	BHP	Rev/min	BHP	Rev/min	BHP	Rev/min	BHP
425	900	464	0.07	0.10	0.13	0.17	0.21	0.26	0.31	0.36	0.41	0.46	0.51	0.56	0.61	0.66	0.71
470	1000	482	0.09	0.12	0.15	0.19	0.24	0.29	0.34	0.39	0.44	0.49	0.54	0.59	0.64	0.69	0.74
520	1100	504	0.10	0.14	0.17	0.21	0.26	0.31	0.36	0.41	0.46	0.51	0.56	0.61	0.66	0.71	0.76
565	1200	528	0.13	0.17	0.20	0.24	0.29	0.34	0.39	0.44	0.49	0.54	0.59	0.64	0.69	0.74	0.79
615	1300	556	0.16	0.21	0.24	0.29	0.34	0.39	0.44	0.49	0.54	0.59	0.64	0.69	0.74	0.79	0.84
660	1400	592	0.18	0.24	0.27	0.32	0.37	0.42	0.47	0.52	0.57	0.62	0.67	0.72	0.77	0.82	0.87
710	1500	641	0.19	0.26	0.29	0.33	0.38	0.43	0.48	0.53	0.58	0.63	0.68	0.73	0.78	0.83	0.88
755	1600	696	0.21	0.28	0.32	0.36	0.41	0.46	0.51	0.56	0.61	0.66	0.71	0.76	0.81	0.86	0.91
800	1700	750	0.23	0.31	0.35	0.39	0.43	0.47	0.51	0.55	0.59	0.63	0.67	0.71	0.75	0.79	0.83
850	1800	799	0.26	0.35	0.39	0.43	0.47	0.51	0.55	0.59	0.63	0.67	0.71	0.75	0.79	0.83	0.87
900	1900	840	0.30	0.40	0.44	0.48	0.52	0.56	0.60	0.64	0.68	0.72	0.76	0.80	0.84	0.88	0.92
945	2000	883	0.36	0.48	0.53	0.57	0.62	0.66	0.70	0.74	0.78	0.82	0.86	0.90	0.94	0.98	1.02

Air Volume		External Static - Pa (in.w.g.)															
		225 (0.90)		250 (1.00)		275 (1.10)		300 (1.20)		325 (1.30)		350 (1.40)		375 (1.50)		400 (1.60)	
L/s	cfm	Rev/min	BHP	Rev/min	BHP	Rev/min	BHP	Rev/min	BHP	Rev/min	BHP	Rev/min	BHP	Rev/min	BHP	Rev/min	BHP
425	900	995	0.21	0.28	0.31	0.34	0.38	0.41	0.44	0.47	0.51	0.54	0.58	0.61	0.65	0.68	0.72
470	1000	999	0.23	0.31	0.34	0.38	0.41	0.44	0.47	0.51	0.54	0.58	0.61	0.65	0.68	0.72	0.76
520	1100	1006	0.25	0.34	0.38	0.41	0.44	0.47	0.51	0.54	0.58	0.61	0.65	0.68	0.72	0.76	0.80
565	1200	1014	0.28	0.38	0.42	0.45	0.48	0.51	0.54	0.57	0.61	0.64	0.67	0.71	0.74	0.78	0.82
615	1300	1023	0.31	0.42	0.46	0.50	0.53	0.56	0.59	0.62	0.66	0.69	0.73	0.76	0.80	0.84	0.88
660	1400	1035	0.35	0.47	0.51	0.54	0.57	0.61	0.64	0.67	0.71	0.74	0.78	0.81	0.85	0.89	0.93
710	1500	1048	0.39	0.52	0.56	0.59	0.63	0.66	0.70	0.73	0.77	0.80	0.84	0.88	0.92	0.96	1.00
755	1600	1063	0.43	0.57	0.61	0.65	0.68	0.72	0.76	0.79	0.83	0.87	0.91	0.95	0.99	1.03	1.07
800	1700	1079	0.47	0.63	0.67	0.71	0.74	0.78	0.81	0.85	0.88	0.92	0.96	1.00	1.04	1.08	1.12
850	1800	1097	0.51	0.69	0.73	0.77	0.80	0.84	0.88	0.91	0.95	0.99	1.03	1.07	1.11	1.15	1.19
900	1900	1116	0.57	0.76	0.80	0.84	0.87	0.91	0.95	0.99	1.03	1.07	1.11	1.15	1.19	1.23	1.27
945	2000	1148	0.63	0.84	0.88	0.92	0.96	1.00	1.04	1.08	1.12	1.16	1.20	1.24	1.28	1.32	1.36

BLOWER DATA

BELT DRIVE | 5 TON

BLOWER TABLE INCLUDES RESISTANCE FOR BASE UNIT ONLY WITH DRY INDOOR COIL AND AIR FILTERS IN PLACE.

FOR ALL UNITS ADD:

1 - Any factory installed options air resistance (heat section, economizer, etc.).

2 - Any field installed accessories air resistance (duct resistance, diffuser, etc.).

See page 31 for blower motors and drives and wet coil and options/accessory air resistance data.

DOWNFLOW

Air Volume		External Static - Pa (in.w.g.)																	
		25 (0.10)		50 (0.20)		75 (0.30)		100 (0.40)		125 (0.50)		150 (0.60)		175 (0.70)		200 (0.80)			
L/s	cfm	Rev/ min	BHP	Rev/ min	BHP	Rev/ min	BHP	Rev/ min	BHP	Rev/ min	BHP	Rev/ min	BHP	Rev/ min	BHP	Rev/ min	BHP		
520	1100	512	0.11	0.15	0.14	0.19	0.23	0.23	0.26	0.19	0.26	0.19	0.26	0.26	0.26	0.20	0.27	0.22	0.30
565	1200	535	0.13	0.18	0.16	0.22	0.26	0.26	0.30	0.22	0.30	0.22	0.30	0.30	0.30	0.23	0.31	0.25	0.34
615	1300	559	0.16	0.22	0.19	0.26	0.29	0.29	0.34	0.25	0.34	0.25	0.34	0.34	0.34	0.26	0.35	0.28	0.38
660	1400	584	0.19	0.26	0.22	0.29	0.33	0.33	0.37	0.28	0.37	0.28	0.37	0.37	0.37	0.30	0.40	0.32	0.43
710	1500	615	0.22	0.29	0.25	0.33	0.36	0.36	0.41	0.31	0.41	0.31	0.41	0.41	0.41	0.33	0.44	0.35	0.47
755	1600	665	0.22	0.30	0.25	0.34	0.38	0.38	0.44	0.33	0.44	0.33	0.44	0.44	0.44	0.37	0.49	0.39	0.52
800	1700	723	0.23	0.31	0.26	0.35	0.39	0.39	0.47	0.35	0.47	0.35	0.47	0.47	0.47	0.40	0.54	0.43	0.58
850	1800	779	0.24	0.32	0.28	0.37	0.41	0.41	0.49	0.37	0.50	0.37	0.50	0.50	0.50	0.44	0.59	0.48	0.64
900	1900	826	0.27	0.36	0.31	0.41	0.45	0.45	0.56	0.42	0.56	0.42	0.56	0.56	0.56	0.49	0.66	0.52	0.70
945	2000	857	0.31	0.42	0.35	0.47	0.52	0.52	0.62	0.46	0.62	0.46	0.62	0.62	0.62	0.54	0.73	0.57	0.77
990	2100	878	0.37	0.49	0.40	0.54	0.59	0.59	0.70	0.52	0.70	0.52	0.70	0.70	0.70	0.60	0.80	0.63	0.85
1040	2200	897	0.41	0.55	0.46	0.61	0.66	0.66	0.78	0.58	0.78	0.58	0.78	0.78	0.78	0.66	0.89	0.69	0.93
1085	2300	918	0.46	0.62	0.51	0.68	0.74	0.74	0.86	0.64	0.86	0.64	0.86	0.86	0.86	0.72	0.97	0.76	1.02
1135	2400	941	0.52	0.70	0.57	0.77	0.83	0.83	0.96	0.72	0.96	0.72	0.96	0.96	0.96	0.79	1.06	0.83	1.11

Air Volume		External Static - Pa (in.w.g.)																	
		225 (0.90)		250 (1.00)		275 (1.10)		300 (1.20)		325 (1.30)		350 (1.40)		375 (1.50)		400 (1.60)			
L/s	cfm	Rev/ min	BHP	Rev/ min	BHP	Rev/ min	BHP	Rev/ min	BHP	Rev/ min	BHP	Rev/ min	BHP	Rev/ min	BHP	Rev/ min	BHP		
520	1100	1006	0.26	0.35	0.29	0.39	0.43	0.43	0.46	0.34	0.46	0.34	0.46	0.46	0.46	0.46	0.46	0.46	0.46
565	1200	1013	0.28	0.38	0.31	0.42	0.46	0.46	0.50	0.37	0.50	0.37	0.50	0.50	0.50	0.50	0.50	0.50	0.50
615	1300	1022	0.31	0.42	0.34	0.46	0.50	0.50	0.54	0.40	0.54	0.40	0.54	0.54	0.54	0.54	0.54	0.54	0.54
660	1400	1033	0.35	0.47	0.38	0.51	0.55	0.55	0.58	0.43	0.58	0.43	0.58	0.58	0.58	0.58	0.58	0.58	0.58
710	1500	1045	0.39	0.52	0.42	0.56	0.60	0.60	0.63	0.47	0.63	0.47	0.63	0.63	0.63	0.63	0.63	0.63	0.63
755	1600	1059	0.43	0.57	0.46	0.61	0.65	0.65	0.68	0.51	0.68	0.51	0.68	0.68	0.68	0.68	0.68	0.68	0.68
800	1700	1074	0.46	0.62	0.49	0.66	0.70	0.70	0.74	0.55	0.74	0.55	0.74	0.74	0.74	0.74	0.74	0.74	0.74
850	1800	1091	0.51	0.68	0.54	0.72	0.76	0.76	0.80	0.60	0.80	0.60	0.80	0.80	0.80	0.80	0.80	0.80	0.80
900	1900	1109	0.56	0.75	0.59	0.79	0.82	0.82	0.86	0.64	0.86	0.64	0.86	0.86	0.86	0.86	0.86	0.86	0.86
945	2000	1128	0.61	0.82	0.64	0.86	0.89	0.89	0.93	0.69	0.93	0.69	0.93	0.93	0.93	0.93	0.93	0.93	0.93
990	2100	1148	0.66	0.89	0.69	0.93	0.97	0.97	1.01	0.75	1.01	0.75	1.01	1.01	1.01	1.01	1.01	1.01	1.01
1040	2200	1170	0.72	0.97	0.75	1.01	1.05	1.05	1.09	0.81	1.09	0.81	1.09	1.09	1.09	1.09	1.09	1.09	1.09
1085	2300	1193	0.79	1.06	0.81	1.09	1.14	1.14	1.19	0.89	1.19	0.89	1.19	1.19	1.19	1.19	1.19	1.19	1.19
1135	2400	1216	0.86	1.15	0.89	1.19	1.24	1.24	1.30	0.97	1.30	0.97	1.30	1.30	1.30	1.30	1.30	1.30	1.30

BLOWER DATA

BELT DRIVE | 5 TON

BLOWER TABLE INCLUDES RESISTANCE FOR BASE UNIT ONLY WITH DRY INDOOR COIL AND AIR FILTERS IN PLACE.

FOR ALL UNITS ADD:

1 - Any factory installed options air resistance (heat section, economizer, etc.).

2 - Any field installed accessories air resistance (duct resistance, diffuser, etc.).

See page 31 for blower motors and drives and wet coil and options/accessory air resistance data.

HORIZONTAL

Air Volume		External Static - Pa (in.w.g.)																				
		25 (0.10)		50 (0.20)		75 (0.30)		100 (0.40)		125 (0.50)		150 (0.60)		175 (0.70)		200 (0.80)						
L/s	cfm	Rev/min	kW	BHP	Rev/min	kW	BHP	Rev/min	kW	BHP	Rev/min	kW	BHP	Rev/min	kW	BHP	Rev/min	kW	BHP			
520	1100	509	0.11	0.15	562	0.13	0.18	0.20	0.16	0.22	771	0.18	0.24	852	0.19	0.25	919	0.21	0.28	970	0.23	0.31
565	1200	535	0.13	0.18	589	0.16	0.21	0.23	0.19	0.25	792	0.20	0.27	869	0.22	0.29	932	0.24	0.32	980	0.26	0.35
615	1300	564	0.16	0.21	618	0.18	0.24	0.27	0.22	0.29	815	0.23	0.31	887	0.25	0.33	946	0.27	0.36	991	0.29	0.39
660	1400	604	0.18	0.24	657	0.20	0.27	0.30	0.25	0.33	842	0.26	0.35	908	0.28	0.37	962	0.30	0.40	1004	0.32	0.43
710	1500	656	0.19	0.26	706	0.22	0.30	0.33	0.27	0.36	874	0.29	0.39	931	0.31	0.41	979	0.34	0.45	1019	0.36	0.48
755	1600	712	0.22	0.29	758	0.24	0.32	0.36	0.29	0.39	906	0.32	0.43	955	0.34	0.46	997	0.37	0.50	1035	0.40	0.54
800	1700	766	0.24	0.32	808	0.27	0.36	0.40	0.33	0.44	936	0.35	0.47	978	0.38	0.51	1016	0.42	0.56	1052	0.45	0.60
850	1800	814	0.27	0.36	851	0.30	0.40	0.44	0.37	0.49	963	0.40	0.53	1000	0.43	0.57	1035	0.46	0.62	1071	0.49	0.66
900	1900	853	0.31	0.41	886	0.34	0.46	0.50	0.41	0.55	986	0.45	0.60	1021	0.48	0.64	1056	0.51	0.69	1091	0.54	0.73
945	2000	883	0.36	0.48	913	0.40	0.53	0.57	0.46	0.62	1009	0.50	0.67	1043	0.53	0.71	1078	0.57	0.76	1112	0.60	0.80
990	2100	906	0.42	0.56	936	0.45	0.60	0.65	0.52	0.70	1033	0.56	0.75	1067	0.59	0.79	1101	0.63	0.84	1135	0.66	0.88
1040	2200	930	0.48	0.64	960	0.51	0.68	0.73	0.58	0.78	1058	0.62	0.83	1092	0.66	0.88	1126	0.69	0.92	1160	0.72	0.96
1085	2300	954	0.54	0.72	985	0.57	0.77	0.82	0.65	0.87	1085	0.69	0.92	1119	0.72	0.96	1152	0.75	1.00	1186	0.78	1.04
1135	2400	981	0.60	0.81	1013	0.64	0.86	0.91	0.72	0.96	1113	0.75	1.00	1180	0.78	1.05	1180	0.81	1.09	1213	0.84	1.13

Air Volume		External Static - Pa (in.w.g.)																				
		225 (0.90)		250 (1.00)		275 (1.10)		300 (1.20)		325 (1.30)		350 (1.40)		375 (1.50)		400 (1.60)						
L/s	cfm	Rev/min	kW	BHP	Rev/min	kW	BHP	Rev/min	kW	BHP	Rev/min	kW	BHP	Rev/min	kW	BHP	Rev/min	kW	BHP			
520	1100	1010	0.26	0.35	1049	0.28	0.38	0.42	0.34	0.45	1176	0.58	0.78	1218	0.38	0.51	1258	0.40	0.54	1297	0.43	0.57
565	1200	1019	0.28	0.38	1058	0.31	0.42	0.46	0.37	0.49	1182	0.39	0.52	1223	0.41	0.55	1263	0.43	0.58	1302	0.46	0.61
615	1300	1030	0.32	0.43	1068	0.35	0.47	0.50	0.40	0.53	1190	0.42	0.56	1230	0.44	0.59	1270	0.47	0.63	1308	0.49	0.66
660	1400	1042	0.35	0.47	1080	0.38	0.51	0.55	0.43	0.58	1200	0.46	0.61	1240	0.48	0.65	1278	0.51	0.68	1315	0.54	0.72
710	1500	1056	0.40	0.53	1094	0.43	0.57	0.60	0.47	0.63	1212	0.50	0.67	1250	0.52	0.70	1288	0.55	0.74	1324	0.57	0.77
755	1600	1071	0.43	0.58	1109	0.46	0.62	0.66	0.51	0.69	1225	0.54	0.72	1263	0.57	0.76	1299	0.60	0.80	1334	0.62	0.83
800	1700	1088	0.48	0.64	1126	0.51	0.68	0.78	0.56	0.75	1240	0.58	0.78	1276	0.61	0.82	1311	0.64	0.86	1345	0.67	0.90
850	1800	1107	0.52	0.70	1143	0.55	0.74	0.85	0.60	0.81	1256	0.63	0.85	1290	0.66	0.89	1324	0.69	0.93	1357	0.72	0.97
900	1900	1126	0.57	0.77	1163	0.60	0.81	0.92	0.66	0.88	1273	0.69	0.92	1306	0.72	0.96	1339	0.75	1.00	1371	0.78	1.04
945	2000	1148	0.63	0.84	1183	0.66	0.88	0.99	0.72	0.96	1291	0.75	1.00	1323	0.78	1.04	1354	0.81	1.08	1385	0.84	1.12
990	2100	1170	0.69	0.92	1206	0.72	0.96	1.07	0.78	1.04	1310	0.81	1.08	1340	0.84	1.13	1370	0.87	1.17	1401	0.90	1.21
1040	2200	1195	0.75	1.00	1230	0.78	1.04	1.15	0.84	1.13	1330	0.88	1.18	1359	0.92	1.23	1388	0.95	1.27	1418	0.98	1.31
1085	2300	1220	0.81	1.08	1254	0.84	1.13	1.28	0.92	1.23	1350	0.95	1.28	1378	1.00	1.34	1406	1.03	1.38	1435	1.06	1.42
1135	2400	1245	0.88	1.18	1278	0.91	1.22	1.31	0.99	1.33	1370	1.04	1.40	1397	1.08	1.45	1425	1.12	1.50	1454	1.15	1.54

BLOWER DATA

BELT DRIVE | 6 TON

BLOWER TABLE INCLUDES RESISTANCE FOR BASE UNIT ONLY WITH DRY INDOOR COIL AND AIR FILTERS IN PLACE.

FOR ALL UNITS ADD:

1 - Any factory installed options air resistance (heat section, economizer, etc.).

2 - Any field installed accessories air resistance (duct resistance, diffuser, etc.).

See page 31 for blower motors and drives and wet coil and options/accessory air resistance data.

DOWNFLOW

Air Volume		External Static - Pa (in.w.g.)															
		25 (0.10)		50 (0.20)		75 (0.30)		100 (0.40)		125 (0.50)		150 (0.60)		175 (0.70)		200 (0.80)	
L/s	cfm	Rev/ min	BHP	Rev/ min	BHP	Rev/ min	BHP	Rev/ min	BHP	Rev/ min	BHP	Rev/ min	BHP	Rev/ min	BHP	Rev/ min	BHP
895	1900	826	0.27	0.31	0.42	0.49	0.55	0.62	0.70	0.79	0.86	0.93	1.00	1.08	1.15	1.22	1.30
945	2000	857	0.31	0.35	0.47	0.54	0.61	0.68	0.74	0.81	0.88	0.95	1.02	1.10	1.17	1.25	1.33
990	2100	878	0.37	0.40	0.49	0.54	0.61	0.68	0.74	0.81	0.88	0.95	1.02	1.10	1.17	1.25	1.33
1040	2200	897	0.41	0.46	0.55	0.61	0.68	0.74	0.81	0.88	0.95	1.02	1.10	1.17	1.25	1.33	1.41
1085	2300	918	0.46	0.51	0.62	0.68	0.74	0.81	0.88	0.95	1.02	1.10	1.17	1.25	1.33	1.41	1.49
1135	2400	941	0.52	0.57	0.70	0.77	0.83	0.90	0.96	1.03	1.10	1.16	1.23	1.30	1.37	1.44	1.51
1180	2500	966	0.59	0.64	0.79	0.86	0.93	1.00	1.06	1.13	1.20	1.27	1.34	1.41	1.48	1.55	1.62
1225	2600	994	0.67	0.72	0.90	0.97	1.04	1.10	1.16	1.23	1.30	1.37	1.44	1.51	1.58	1.65	1.72
1275	2700	1023	0.75	0.81	1.01	1.08	1.15	1.22	1.29	1.36	1.43	1.50	1.57	1.64	1.71	1.78	1.85
1320	2800	1053	0.84	0.90	1.13	1.21	1.27	1.33	1.39	1.45	1.51	1.57	1.63	1.69	1.75	1.81	1.87
1370	2900	1085	0.94	1.00	1.26	1.33	1.40	1.46	1.51	1.57	1.63	1.69	1.75	1.81	1.87	1.93	1.99

Air Volume		External Static - Pa (in.w.g.)															
		225 (0.90)		250 (1.00)		275 (1.10)		300 (1.20)		325 (1.30)		350 (1.40)		375 (1.50)		400 (1.60)	
L/s	cfm	Rev/ min	BHP	Rev/ min	BHP	Rev/ min	BHP	Rev/ min	BHP	Rev/ min	BHP	Rev/ min	BHP	Rev/ min	BHP	Rev/ min	BHP
895	1900	1109	0.56	0.59	0.75	0.79	0.82	0.86	0.89	0.93	0.96	0.99	1.02	1.05	1.08	1.11	1.14
945	2000	1128	0.61	0.64	0.82	0.86	0.89	0.93	0.96	0.99	1.02	1.05	1.08	1.11	1.14	1.17	1.20
990	2100	1148	0.66	0.69	0.89	0.93	0.97	1.01	1.04	1.07	1.10	1.13	1.16	1.19	1.22	1.25	1.28
1040	2200	1170	0.72	0.75	0.97	1.01	1.05	1.09	1.13	1.17	1.21	1.24	1.28	1.31	1.35	1.38	1.42
1085	2300	1193	0.79	0.81	1.06	1.09	1.14	1.19	1.23	1.27	1.31	1.35	1.39	1.43	1.47	1.51	1.55
1135	2400	1216	0.86	0.89	1.15	1.19	1.24	1.28	1.33	1.37	1.41	1.45	1.49	1.53	1.57	1.61	1.65
1180	2500	1240	0.93	0.96	1.24	1.29	1.36	1.42	1.48	1.54	1.60	1.66	1.71	1.77	1.82	1.88	1.93
1225	2600	1265	1.00	1.04	1.34	1.40	1.47	1.54	1.60	1.67	1.74	1.80	1.87	1.93	1.99	2.05	2.11
1275	2700	1291	1.09	1.13	1.46	1.52	1.59	1.67	1.74	1.81	1.88	1.95	2.02	2.09	2.16	2.23	2.29
1320	2800	1317	1.18	1.24	1.58	1.66	1.74	1.80	1.88	1.95	2.02	2.09	2.16	2.23	2.30	2.37	2.44
1370	2900	1343	1.28	1.34	1.72	1.80	1.88	1.95	2.02	2.09	2.16	2.23	2.30	2.37	2.44	2.51	2.58

BLOWER DATA

BELT DRIVE | 6 TON

BLOWER TABLE INCLUDES RESISTANCE FOR BASE UNIT ONLY WITH DRY INDOOR COIL AND AIR FILTERS IN PLACE.

FOR ALL UNITS ADD:

- 1 - Any factory installed options air resistance (heat section, economizer, etc.).
- 2 - Any field installed accessories air resistance (duct resistance, diffuser, etc.).

See page 31 for blower motors and drives and wet coil and options/accessory air resistance data.

HORIZONTAL

Air Volume		External Static - Pa (in.w.g.)																							
		25 (0.10)		50 (0.20)		75 (0.30)		100 (0.40)		125 (0.50)		150 (0.60)		175 (0.70)		200 (0.80)									
L/s	cfm	Rev/min	kW	BHP	Rev/min	kW	BHP	Rev/min	kW	BHP	Rev/min	kW	BHP	Rev/min	kW	BHP	Rev/min	kW	BHP						
895	1900	853	0.31	0.41	886	0.34	0.46	919	0.37	0.50	952	0.41	0.55	986	0.45	0.60	1021	0.48	0.64	1056	0.51	0.69	1091	0.54	0.73
945	2000	883	0.36	0.48	913	0.40	0.53	944	0.43	0.57	976	0.46	0.62	1009	0.50	0.67	1043	0.53	0.71	1078	0.57	0.76	1112	0.60	0.80
990	2100	906	0.42	0.56	936	0.45	0.60	967	0.48	0.65	999	0.52	0.70	1033	0.56	0.75	1067	0.59	0.79	1101	0.63	0.84	1135	0.66	0.88
1040	2200	930	0.48	0.64	960	0.51	0.68	991	0.54	0.73	1024	0.58	0.78	1058	0.62	0.83	1092	0.66	0.88	1126	0.69	0.92	1160	0.72	0.96
1085	2300	954	0.54	0.72	985	0.57	0.77	1017	0.61	0.82	1051	0.65	0.87	1085	0.69	0.92	1119	0.72	0.96	1152	0.75	1.00	1186	0.78	1.04
1135	2400	981	0.60	0.81	1013	0.64	0.86	1046	0.68	0.91	1079	0.72	0.96	1113	0.75	1.00	1146	0.78	1.05	1180	0.81	1.09	1213	0.84	1.13
1180	2500	1010	0.68	0.91	1042	0.72	0.96	1075	0.75	1.00	1109	0.78	1.05	1142	0.81	1.09	1175	0.85	1.14	1207	0.88	1.18	1239	0.92	1.23
1225	2600	1040	0.75	1.01	1073	0.78	1.05	1106	0.82	1.10	1139	0.85	1.14	1171	0.89	1.19	1203	0.92	1.23	1235	0.95	1.28	1266	0.99	1.33
1275	2700	1072	0.82	1.10	1104	0.86	1.15	1137	0.90	1.20	1169	0.93	1.24	1201	0.96	1.29	1232	1.00	1.34	1263	1.04	1.40	1293	1.09	1.46
1320	2800	1105	0.90	1.21	1137	0.93	1.25	1168	0.97	1.30	1200	1.01	1.35	1231	1.04	1.40	1261	1.09	1.46	1291	1.13	1.52	1321	1.19	1.59
1370	2900	1138	0.98	1.32	1169	1.02	1.37	1200	1.06	1.42	1231	1.10	1.47	1261	1.14	1.53	1291	1.19	1.60	1321	1.24	1.66	1350	1.29	1.73

Air Volume		External Static - Pa (in.w.g.)																							
		225 (0.90)		250 (1.00)		275 (1.10)		300 (1.20)		325 (1.30)		350 (1.40)		375 (1.50)		400 (1.60)									
L/s	cfm	Rev/min	kW	BHP	Rev/min	kW	BHP	Rev/min	kW	BHP	Rev/min	kW	BHP	Rev/min	kW	BHP	Rev/min	kW	BHP						
895	1900	1126	0.57	0.77	1163	0.60	0.81	1200	0.63	0.85	1237	0.66	0.88	1273	0.69	0.92	1306	0.72	0.96	1339	0.75	1.00	1371	0.78	1.04
945	2000	1148	0.63	0.84	1183	0.66	0.88	1220	0.69	0.92	1257	0.72	0.96	1291	0.75	1.00	1323	0.78	1.04	1354	0.81	1.08	1385	0.84	1.12
990	2100	1170	0.69	0.92	1206	0.72	0.96	1242	0.75	1.00	1277	0.78	1.04	1310	0.81	1.08	1340	0.84	1.13	1371	0.87	1.17	1401	0.90	1.21
1040	2200	1195	0.75	1.00	1230	0.78	1.04	1265	0.81	1.08	1299	0.84	1.13	1330	0.88	1.18	1359	0.92	1.23	1388	0.95	1.27	1418	0.98	1.31
1085	2300	1220	0.81	1.08	1254	0.84	1.13	1288	0.87	1.17	1320	0.92	1.23	1350	0.95	1.28	1378	1.00	1.34	1406	1.03	1.38	1435	1.06	1.42
1135	2400	1245	0.88	1.18	1278	0.91	1.22	1311	0.95	1.28	1341	0.99	1.33	1370	1.04	1.40	1397	1.08	1.45	1425	1.12	1.50	1454	1.15	1.54
1180	2500	1271	0.95	1.28	1303	0.99	1.33	1334	1.04	1.39	1363	1.08	1.45	1391	1.13	1.52	1418	1.17	1.57	1446	1.21	1.62	1474	1.24	1.66
1225	2600	1297	1.04	1.39	1328	1.08	1.45	1357	1.13	1.52	1385	1.18	1.58	1412	1.22	1.64	1439	1.27	1.70	1467	1.30	1.74	1495	1.33	1.78
1275	2700	1323	1.13	1.52	1353	1.18	1.58	1382	1.23	1.65	1409	1.28	1.72	1435	1.32	1.77	1462	1.36	1.82	1490	1.39	1.86	1517	1.42	1.90
1320	2800	1351	1.23	1.65	1380	1.28	1.72	1407	1.33	1.78	1434	1.38	1.85	1460	1.42	1.90	1486	1.45	1.95	1513	1.48	1.99	1541	1.51	2.02
1370	2900	1379	1.34	1.79	1407	1.39	1.86	1434	1.43	1.92	1460	1.48	1.98	1485	1.52	2.04	1511	1.55	2.08	1538	1.58	2.12	1565	1.60	2.15

BLOWER DATA

BELT DRIVE KIT SPECIFICATIONS - STANDARD EFFICIENCY - 036-074

Model No.	Motor (kW) HP		No. of Speeds	Drive Kits and Rev/Min Range							
	Nominal	Maximum		A01	A02	A03	A04	A05	A06	A07	A08
036	1.5 (2)	1.7 (2.3)	1	561 - 842	---	---	---	748 - 1122	---	---	---
048	1.5 (2)	1.7 (2.3)	1	---	621 - 931	---	---	---	893 - 1191	---	---
060	1.5 (2)	1.7 (2.3)	1	---	---	694 - 1042	---	---	---	1010 - 1290	---
074	1.2 (1.66)	1.4 (1.91)	2	---	---	---	807 - 1117	---	---	---	994 - 1326

NOTE - Using total air volume and system static pressure requirements determine from blower performance tables rev/min and motor output required. Maximum usable output of motors furnished are shown. If motors of comparable output are used, be sure to keep within the service factor limitations outlined on the motor nameplate.

BELT DRIVE KIT SPECIFICATIONS - HIGH EFFICIENCY - 036-060

Model No.	Motor kW		Motor HP		No. of Speeds	Drive Kits and Rev/Min Range					
	Nom.	Max.	Nom.	Max.		A01	A02	A03	A05	A06	A07
036	0.47	0.54	0.63	0.72	2	low 374-561 high 561-842	---	---	---	---	---
	0.62	0.71	0.83	0.95	2	---	---	---	low 498-748 high 748-1122	---	---
048	0.47	0.54	0.63	0.72	2	---	low 414-621 high 621-931	---	---	---	---
	1.24	1.42	1.66	1.91	2	---	---	---	---	low 595-794 high 893-1191	---
060	0.62	0.71	0.83	0.95	2	---	---	low 463-694 high 694-1042	---	---	---
	1.24	1.42	1.66	1.91	2	---	---	---	---	---	low 673-860 high 1010-1290

NOTE - Using total air volume and system static pressure requirements determine from blower performance tables rev/min and motor output required. Maximum usable output of motors furnished are shown. If motors of comparable output are used, be sure to keep within the service factor limitations outlined on the motor nameplate.

OPTIONS / ACCESSORIES AIR RESISTANCE

Air Volume		Wet Indoor Coil				Economizer		Electric Heat		Filters			
		036-048		060-074						MERV 8		MERV 13	
L/s	cfm	Pa	in. w.g.	Pa	in. w.g.	Pa	in. w.g.	Pa	in. w.g.	Pa	in. w.g.	Pa	in. w.g.
375	800	2	0.01	2	0.01	10	0.04	2	0.01	7	0.04	12	0.05
470	1000	5	0.02	2	0.01	10	0.04	7	0.03	7	0.04	17	0.07
565	1200	5	0.02	2	0.01	10	0.04	15	0.06	7	0.04	17	0.07
660	1400	7	0.03	5	0.02	10	0.04	22	0.09	7	0.04	17	0.07
755	1600	10	0.04	7	0.03	10	0.04	30	0.12	7	0.04	17	0.07
850	1800	12	0.05	7	0.04	12	0.05	37	0.15	12	0.05	17	0.07
945	2000	15	0.06	12	0.05	12	0.05	45	0.18	12	0.05	20	0.08
1040	2200	20	0.08	15	0.06	12	0.05	50	0.20	12	0.05	20	0.08
1130	2400	22	0.09	17	0.07	12	0.05	55	0.22	12	0.05	20	0.08
1225	2600	25	0.10	20	0.08	15	0.06	60	0.24	12	0.05	20	0.08
1320	2800	27	0.11	22	0.09	15	0.06	65	0.26	12	0.05	20	0.08
1415	3000	30	0.13	25	0.10	15	0.06	70	0.28	12	0.05	20	0.08

POWER EXHAUST FAN PERFORMANCE

Return Air System Static Pressure		Air Volume Exhausted	
Pa	in. w.g.	L/s	cfm
0	0.00	944	2000
12	0.05	939	1990
25	0.10	908	1924
37	0.15	854	1810
50	0.20	785	1664
62	0.25	711	1507
75	0.30	637	1350
87	0.35	571	1210

BLOWER DATA

CEILING DIFFUSERS AIR RESISTANCE

Air Volume		RTD9-65S Step-Down Diffuser						FD9-65S Flush Diffuser		RTD11-95S Step-Down Diffuser						FD11-95S Flush Diffuser	
		2 Ends Open		1 Side & 2 Ends Open		All Ends & Sides Open				2 Ends Open		1 Side & 2 Ends Open		All Ends & Sides Open			
L/s	cfm	Pa	in. w.g.	Pa	in. w.g.	Pa	in. w.g.	Pa	in. w.g.	Pa	in. w.g.	Pa	in. w.g.	Pa	in. w.g.	Pa	in. w.g.
375	800	37	0.15	32	0.13	27	0.11	27	0.11	---	---	---	---	---	---	---	---
470	1000	47	0.19	40	0.16	35	0.14	35	0.14	---	---	---	---	---	---	---	---
565	1200	62	0.25	50	0.20	42	0.17	42	0.17	---	---	---	---	---	---	---	---
660	1400	82	0.33	65	0.26	50	0.20	50	0.20	---	---	---	---	---	---	---	---
755	1600	107	0.43	80	0.32	50	0.20	50	0.24	---	---	---	---	---	---	---	---
850	1800	139	0.56	99	0.40	75	0.30	75	0.30	32	0.13	27	0.11	22	0.09	22	0.09
945	2000	182	0.73	124	0.50	90	0.36	90	0.36	37	0.15	32	0.13	27	0.11	25	0.10
1040	2200	236	0.95	157	0.63	109	0.44	109	0.44	45	0.18	37	0.15	30	0.12	30	0.12
1130	2400	---	---	---	---	---	---	---	---	52	0.21	45	0.18	37	0.15	35	0.14
1225	2600	---	---	---	---	---	---	---	---	60	0.24	52	0.21	45	0.18	42	0.17
1320	2800	---	---	---	---	---	---	---	---	67	0.27	60	0.24	52	0.21	50	0.20
1415	3000	---	---	---	---	---	---	---	---	80	0.32	72	0.29	62	0.25	62	0.25

CEILING DIFFUSER AIR THROW DATA

Air Volume		¹ Effective Throw			
Model No.		RTD9-65S		FD9-65S	
L/s	cfm	m	ft.	m	ft.
375	800	3 - 5	10 - 17	4 - 5	14 - 18
470	1000	3 - 5	10 - 17	5 - 6	15 - 20
565	1200	3 - 5	11 - 18	5 - 7	16 - 22
660	1400	4 - 6	12 - 19	5 - 7	17 - 24
755	1600	4 - 6	12 - 20	5 - 8	18 - 25
850	1800	4 - 6	13 - 21	6 - 9	20 - 28
945	2000	4 - 7	14 - 23	6 - 9	21 - 29
1040	2200	5 - 8	16 - 25	7 - 9	22 - 30
Model No.		RTD11-95S		FD11-95S	
1225	2600	7 - 9	24 - 29	6 - 7	19 - 24
1320	2800	8 - 9	25 - 30	6 - 9	20 - 28
1415	3000	8 - 10	27 - 33	6 - 9	21 - 29

¹ Effective throw based on terminal velocities of 23 m per minute (75 ft. per minute).

ELECTRICAL DATA / ELECTRIC HEAT DATA **STANDARD EFFICIENCY**

Model No.		KHB036S4	KHB048S4	KHB060S4	KHB074S4
¹ Voltage - 50hz with Neutral		380/420V - 3 Ph	380/420V - 3 Ph	380/420V - 3 Ph	380/420V - 3 Ph
Compressor	Rated Load Amps	4	5.5	8	8.5
	Locked Rotor Amps	31	37	59	66.1
Outdoor Fan Motor	Full Load Amps	1.1	1.1	1.3	1.5
Power Exhaust (1) 0.25 kW	Full Load Amps	1.3	1.3	1.3	1.3
Indoor Blower Motor	kW	1.5	1.5	1.5	1.2
	Full Load Amps	3.6	3.6	3.6	2.9
² Maximum Overcurrent Protection	Unit Only	15	15	20	20
	With (1) 0.25 kW Power Exhaust	15	15	20	20
³ Minimum Circuit Ampacity	Unit Only	10	12	15	16
	With (1) 0.25 kW Power Exhaust	11	13	17	17

ELECTRIC HEAT DATA

Electric Heat Voltage			420V	420V	420V	420V
² Maximum Overcurrent Protection	Unit+	5.7 kW	20	25	30	30
	⁴ Electric Heat	11.5 kW	30	35	35	35
		17.2 kW	---	---	45	45
		23 kW	---	---	---	60
³ Minimum Circuit Ampacity	Unit+	5.7 kW	20	22	25	25
	⁴ Electric Heat	11.5 kW	30	32	35	35
		17.2 kW	---	---	45	45
		23 kW	---	---	---	55
² Maximum Overcurrent Protection	Unit+	5.7 kW	25	25	30	30
	⁴ Electric Heat	11.5 kW	35	35	40	40
	and (1) 0.25 kW Power Exhaust	17.2 kW	---	---	50	50
		23 kW	---	---	---	60
³ Minimum Circuit Ampacity	Unit+	5.7 kW	21	23	27	27
	⁴ Electric Heat	11.5 kW	31	33	36	37
	and (1) 0.25 kW Power Exhaust	17.2 kW	---	---	46	46
		23 kW	---	---	---	56

¹ Extremes of operating range are plus and minus 10% of line voltage.
² Heating, Air Conditioning, Refrigeration type breaker or fuse.
³ Refer to local electrical code to determine wire, fuse and disconnect size requirements.
⁴ Nominal kW based on 420V-3ph-50hz.

ELECTRICAL DATA / ELECTRIC HEAT DATA HIGH EFFICIENCY

Model No.		KHB036H4	KHB048H4	KHB060H4			
¹ Voltage - 50hz with Neutral		380/420V - 3 Ph	380/420V - 3 Ph	380/420V - 3 Ph			
Compressor	Rated Load Amps	5.7	6.4	7.2			
	Locked Rotor Amps	38	41	52			
Outdoor Fan Motor	Full Load Amps	2.8	2.8	2.8			
Power Exhaust (1) 0.25 kW	Full Load Amps	1.3	1.3	1.3			
Indoor Blower Motor	kW	0.47	1.2	0.62	1.2		
	Full Load Amps	1.4	2.6	1.9	2.6		
² Maximum Overcurrent Protection	Unit Only	15	15	15	15	20	20
	With (1) 0.25 kW Power Exhaust	15	15	15	20	20	20
³ Minimum Circuit Ampacity	Unit Only	12	13	13	14	14	15
	With (1) 0.25 kW Power Exhaust	13	14	14	15	15	16

ELECTRIC HEAT DATA

Electric Heat Voltage				420V		420V		420V	
² Maximum Overcurrent Protection	Unit+	5.7 kW		25	25	25	25	25	25
	⁴ Electric Heat	11.5 kW		35	35	35	35	35	35
		17.2 kW		---	---	---	---	45	45
³ Minimum Circuit Ampacity	Unit+	5.7 kW		22	23	23	24	24	25
	⁴ Electric Heat	11.5 kW		32	33	32	34	34	35
		17.2 kW		---	---	---	---	44	45
² Maximum Overcurrent Protection	Unit+	5.7 kW		25	25	25	25	30	25
	⁴ Electric Heat and (1) 0.25 kW Power Exhaust	11.5 kW		35	35	35	35	35	35
		17.2 kW		---	---	---	---	45	45
³ Minimum Circuit Ampacity	Unit+	5.7 kW		23	24	24	25	25	30
	⁴ Electric Heat and (1) 0.25 kW Power Exhaust	11.5 kW		33	34	34	35	35	40
		17.2 kW		---	---	---	---	45	50
³ Minimum Circuit Ampacity	Unit+	5.7 kW		---	---	---	---	25	26
	⁴ Electric Heat and (1) 0.25 kW Power Exhaust	11.5 kW		---	---	---	---	35	36
		17.2 kW		---	---	---	---	45	46

² Extremes of operating range are plus and minus 10% of line voltage.

² Heating, Air Conditioning, Refrigeration type breaker or fuse.

³ Refer to local electrical code to determine wire, fuse and disconnect size requirements.

⁴ Nominal kW based on 420V-3ph-50hz.

ELECTRIC HEAT CAPACITIES

Input Voltage	5.7 kW			11.5 kW			17.2 kW			23 kW		
	No of Steps	kW input	Btuh Output	No of Steps	kW input	Btuh Output	No of Steps	kW input	Btuh Output	No of Steps	kW input	Btuh Output
380	1	4.7	16 100	1	9.4	32 100	1	14.1	48 200	1	18.8	64 200
400	1	5.2	17 800	1	10.4	35 500	1	15.6	53 300	1	20.9	71 400
420	1	5.7	19 500	1	11.5	39 300	1	17.2	58 800	1	23.0	78 500

UNIT CLEARANCES

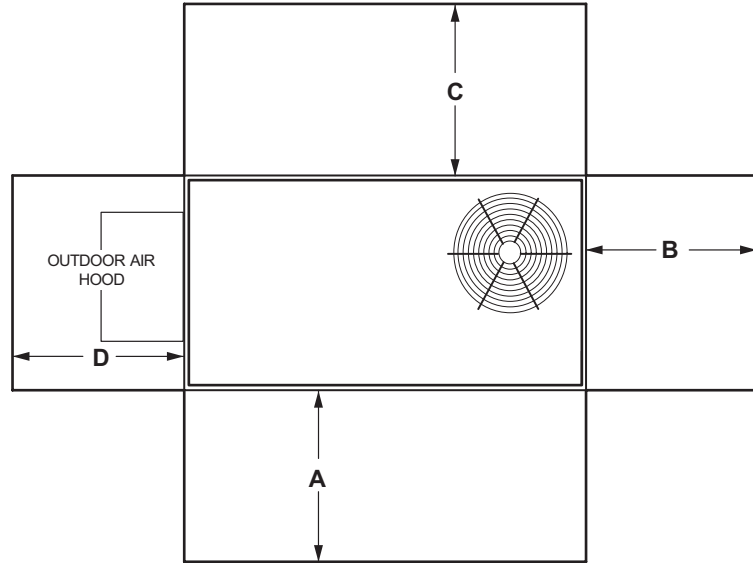

¹ Unit Clearance	A		B		C		D		Top Clearance
	mm	in.	mm	in.	mm	in.	mm	in.	
Service Clearance	914	36	914	36	914	36	914	36	Unobstructed
Minimum Operation Clearance	914	36	914	36	914	36	914	36	

NOTE - Entire perimeter of unit base requires support when elevated above the mounting surface.

¹ Service Clearance - Required for removal of serviceable parts.

Minimum Operation Clearance - Required clearance for proper unit operation.

OUTDOOR SOUND DATA

¹ Unit Model No.	Octave Band Sound Power Levels dBA, re 10 ⁻¹² Watts - Center Frequency - Hz							¹ Sound Rating Number (dBA)
	125	250	500	1000	2000	4000	8000	
KHB036S	62	67	72	69	66	61	56	75
KHB048S	61	67	70	70	68	63	56	75
KHB060S	69	72	75	74	70	65	55	80
KHB074S	67	75	78	78	75	68	59	83
KHB036H	62.1	66.2	70.8	69.4	64	57.4	51.1	75
KHB048H	66.8	67.8	72.6	72.1	68	63.1	52.9	77
KHB060H	65.7	67.9	70.4	72.2	68.5	63.4	55.5	77

NOTE - The octave sound power data does not include tonal corrections.

¹ Sound Rating Number according to AHRI Standard 270-95 (includes pure tone penalty). Sound Rating Number is the overall A-Weighted Sound Power Level, (LWA), dBA (100 Hz to 10,000 Hz).

WEIGHT DATA

Model Number	Net				Shipping			
	Base		Max.		Base		Max.	
	kg	lbs.	kg	lbs.	kg	lbs.	kg	lbs.
KHB036S	257	566	301	664	275	607	320	705
KHB036H	257	568	310	685	276	608	330	725
KHB048S	291	641	348	767	309	682	367	808
KHB048H	290	641	345	760	309	681	362	800
KHB060S	311	686	359	792	330	727	378	833
KHB060H	330	727	384	846	357	787	411	906
KHB074S	340	750	391	862	367	810	422	931

Base Unit - The unit with NO OPTIONS.

Max. Unit - The unit with ALL OPTIONS Installed (Economizer, etc.)

OPTIONS / ACCESSORIES

	Shipping Weights		
	kg	lbs.	
ECONOMIZER			
Economizer			
Economizer, Includes Outdoor Air Hood and Barometric Relief Dampers with Hood	59	131	
OUTDOOR AIR			
Outdoor Air Dampers			
Motorized	18	40	
Manual	14	30	
POWER EXHAUST			
Standard Static	16	35	
ELECTRIC HEAT			
5.7 kW	14	31	
11.5 kW	14	31	
17.2 kW	16	35	
23 kW	16	35	
ROOF CURBS			
Hybrid Roof Curbs, Downflow			
203 mm height	23	50	
356 mm height	32	70	
457 mm height	36	80	
610 mm height	45	100	
Hybrid Curbs, Full Perimeter, Downflow			
203 mm height	26	57	
356 mm height	27	60	
457 mm height	41	91	
610 mm height	52	114	
Adjustable Pitch Curb, Downflow			
356 mm height	51	113	
CEILING DIFFUSERS			
Step-Down	RTD9-65S	36	80
	RTD11-95S	54	118
Flush	FD9-65S	36	80
	FD11-95S	54	118
Transitions (Supply and Return)	T1TRAN10AN1	10	22
	T1TRAN20N-1	10	21

DIMENSIONS - UNIT

Model No.	CORNER WEIGHTS												CENTER OF GRAVITY											
	AA		BB		CC		DD		EE		FF		Base		Max.		Base		Max.					
	kg	lbs.	kg	lbs.	kg	lbs.	kg	lbs.	kg	lbs.	mm	in.	mm	in.	mm	in.	mm	in.	mm	in.				
036S	54	119	64	140	67	149	70	153	75	165	77	170	60	133	91	201	965	38	1111	43-3/4	565	22-1/4	565	22-1/4
036H	55	122	68	150	65	144	77	170	74	164	88	193	63	138	78	171	991	39	1016	40	559	22	559	22
048S	58	128	69	153	72	159	80	177	89	197	109	239	72	158	90	198	965	38	991	39	533	21	508	20
048H	62	137	76	167	74	163	85	188	84	185	98	215	71	156	86	190	965	38	1067	42	559	22	559	22
060S	62	137	72	158	77	170	79	175	95	210	107	236	77	169	101	223	965	38	1041	41	533	21	508	20
060H	73	162	98	217	87	192	91	201	99	218	104	229	83	184	112	247	1143	45	1295	51	559	22	559	22
074S	73	160	84	185	82	180	94	208	106	233	122	269	94	207	108	239	1174	46-1/4	1174	46-1/4	521	20-1/2	521	20-1/2

Base Unit - The unit with standard heat exchanger NO OPTIONS.
 Max. Unit - The unit with ALL OPTIONS Installed (Economizer, etc.).

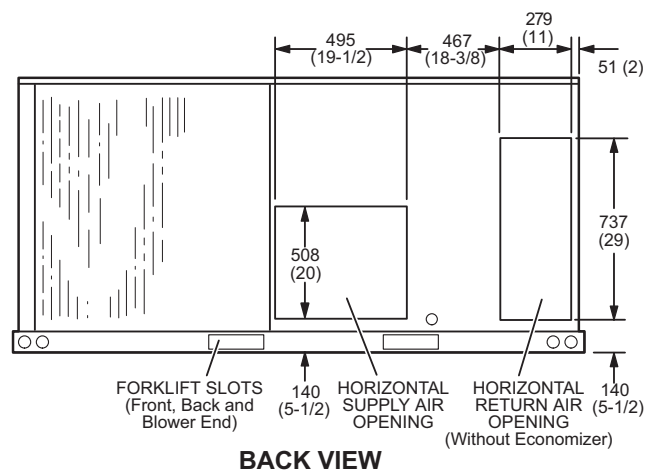
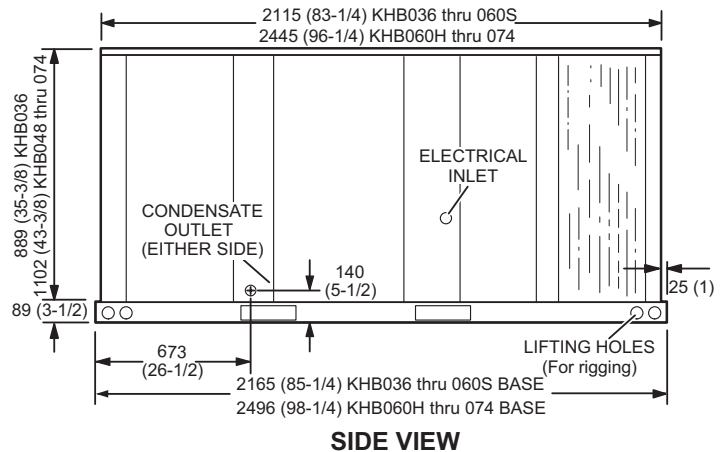
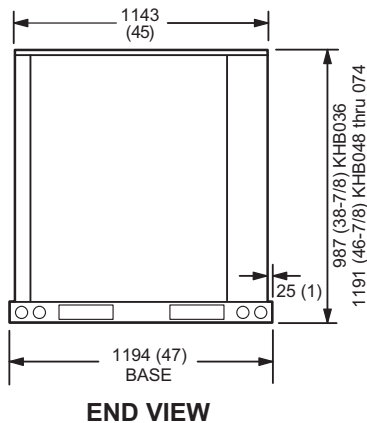
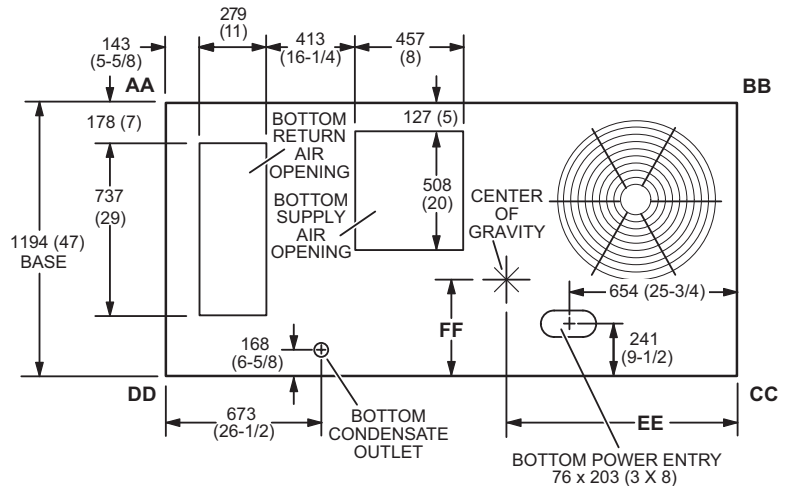

DIMENSIONS - ACCESSORIES

COMBINATION OUTDOOR AIR HOOD DETAIL FOR OPTIONAL ECONOMIZER AND BAROMETRIC RELIEF DAMPERS (Furnished With Economizer for Downflow Applications)

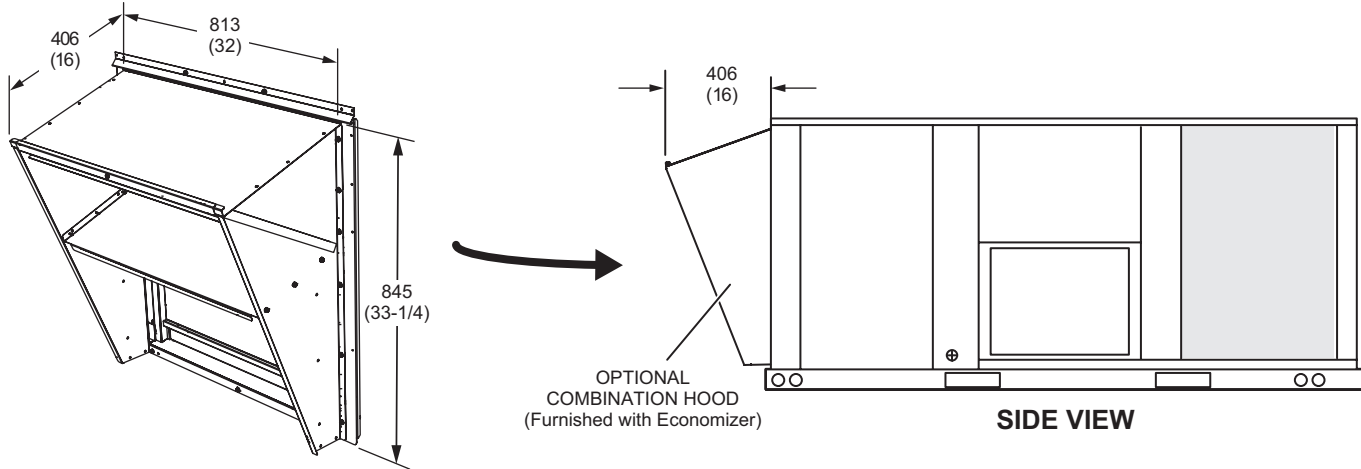

OUTDOOR AIR DAMPER HOOD DETAIL (Downflow or Horizontal Applications)

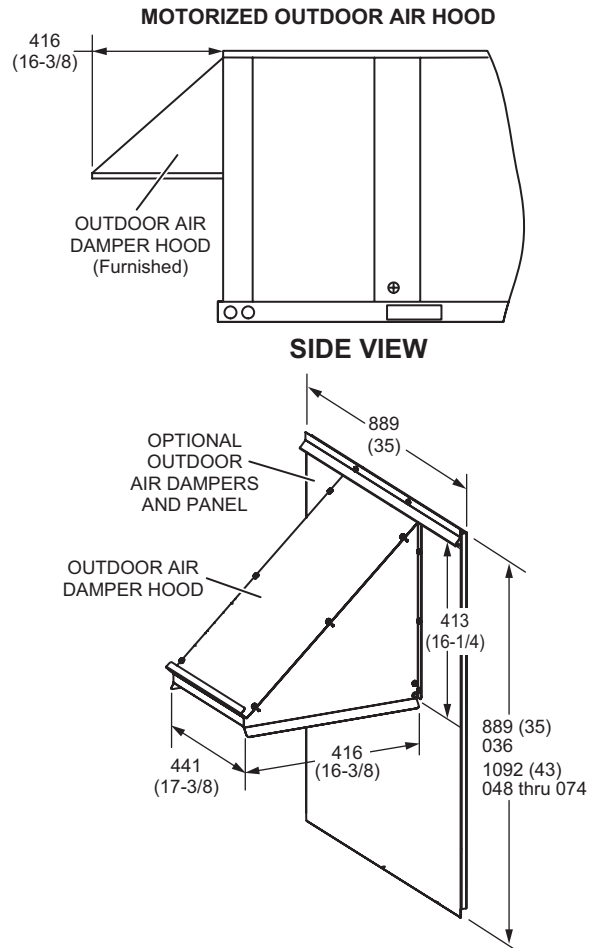
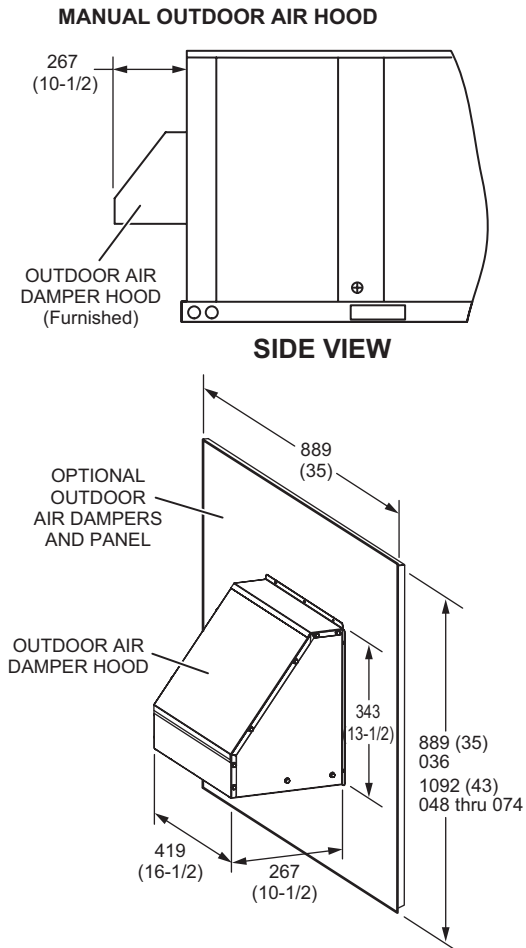

DIMENSIONS - ACCESSORIES

OUTDOOR AIR HOOD DETAIL WITH OPTIONAL ECONOMIZER AND OPTIONAL BAROMETRIC RELIEF DAMPERS WITH HOOD (Horizontal Application)

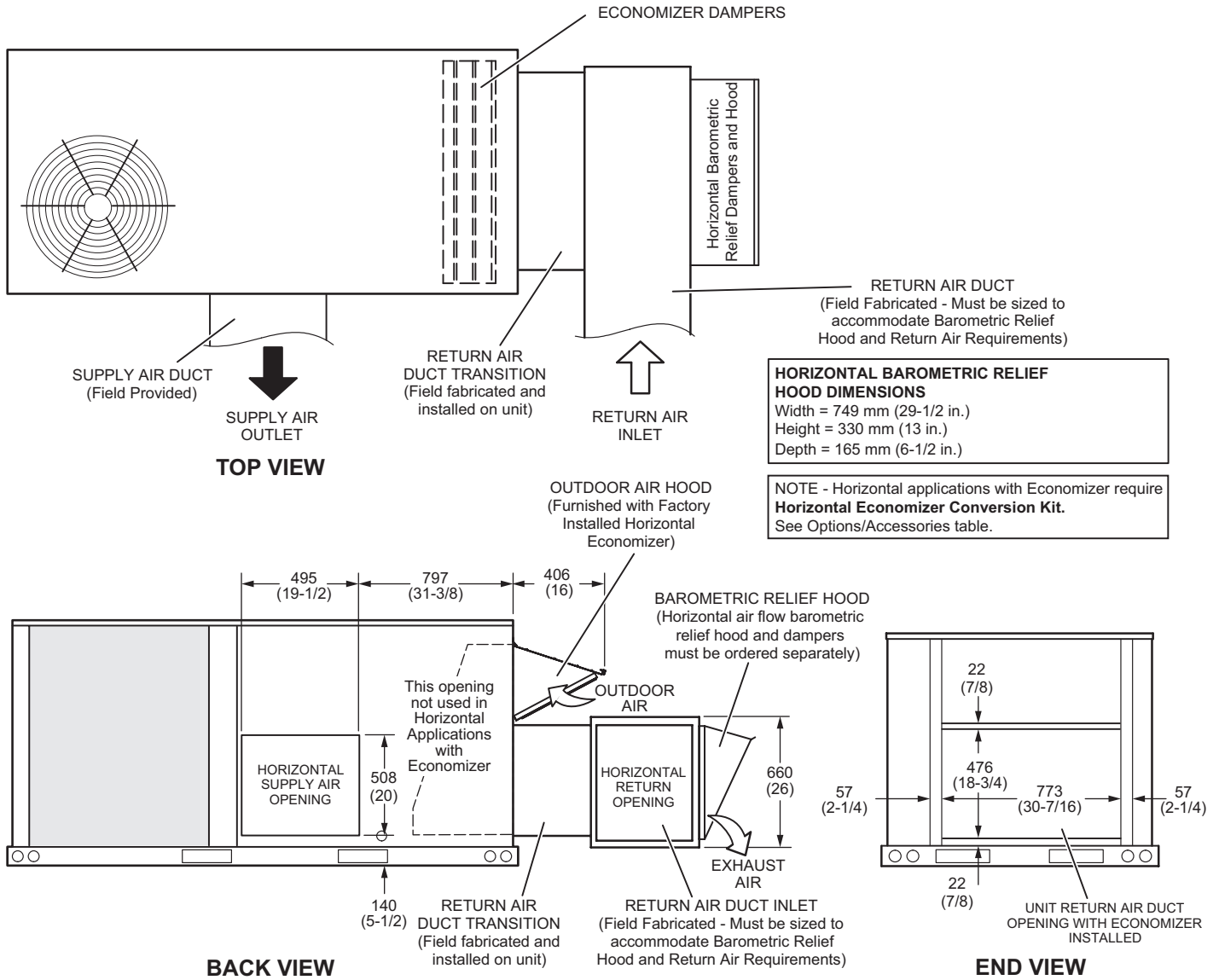

NOTE - Return Air Duct and Transition must be supported

DIMENSIONS - ACCESSORIES

HYBRID ROOF CURBS - DOUBLE DUCT OPENING - STANDARD AND FULL PERIMETER

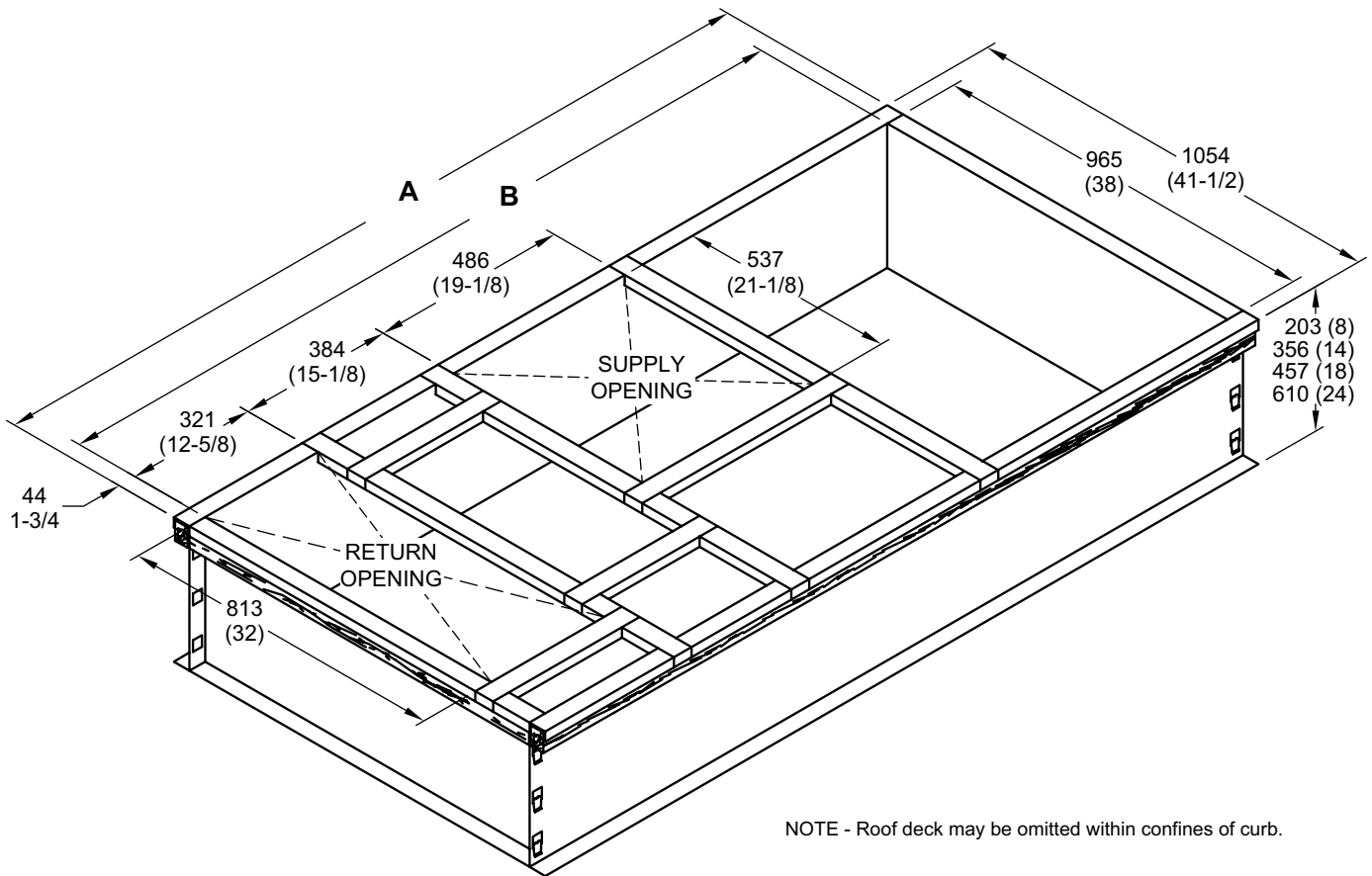

TYPICAL FLASHING DETAIL FOR ROOF CURB

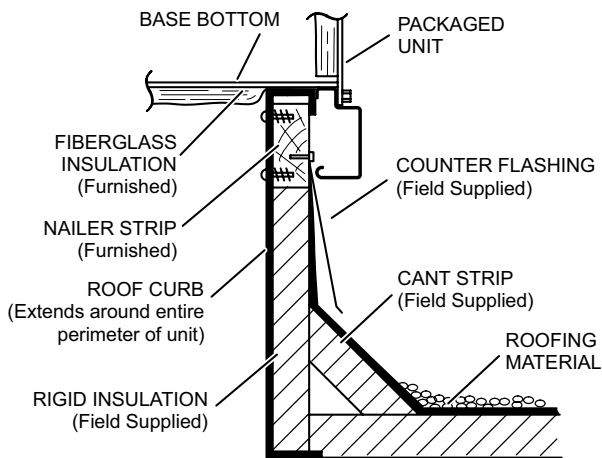

DETAIL ROOF CURB

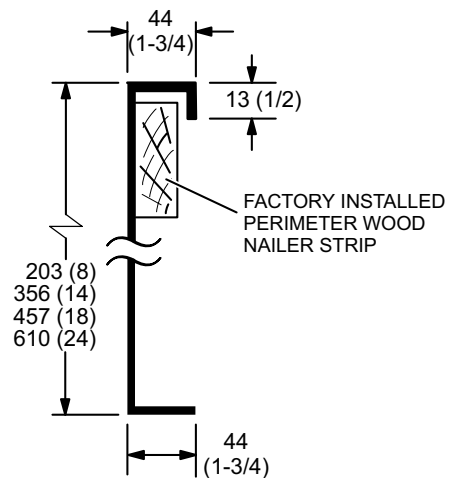

Model No.	A		B	
	mm	in.	mm	in.
Standard - 036, 048, 060S, ¹ 060H, ¹ 074	2026	79-3/4	1937	76-1/4
Full Perimeter - 060H, 074	2356	92-3/4	2267	89-1/4

¹ 060H and 074 models can be used on smaller 2026 mm (79-3/4 in.) roof curbs (not full perimeter) with 400 mm (15-3/4 in.) overhang at condenser end of unit. See dimension drawing on page 42.

DIMENSIONS - ADJUSTABLE PITCH CURB

ADJUSTABLE PITCH CURBS - DOUBLE DUCT OPENING

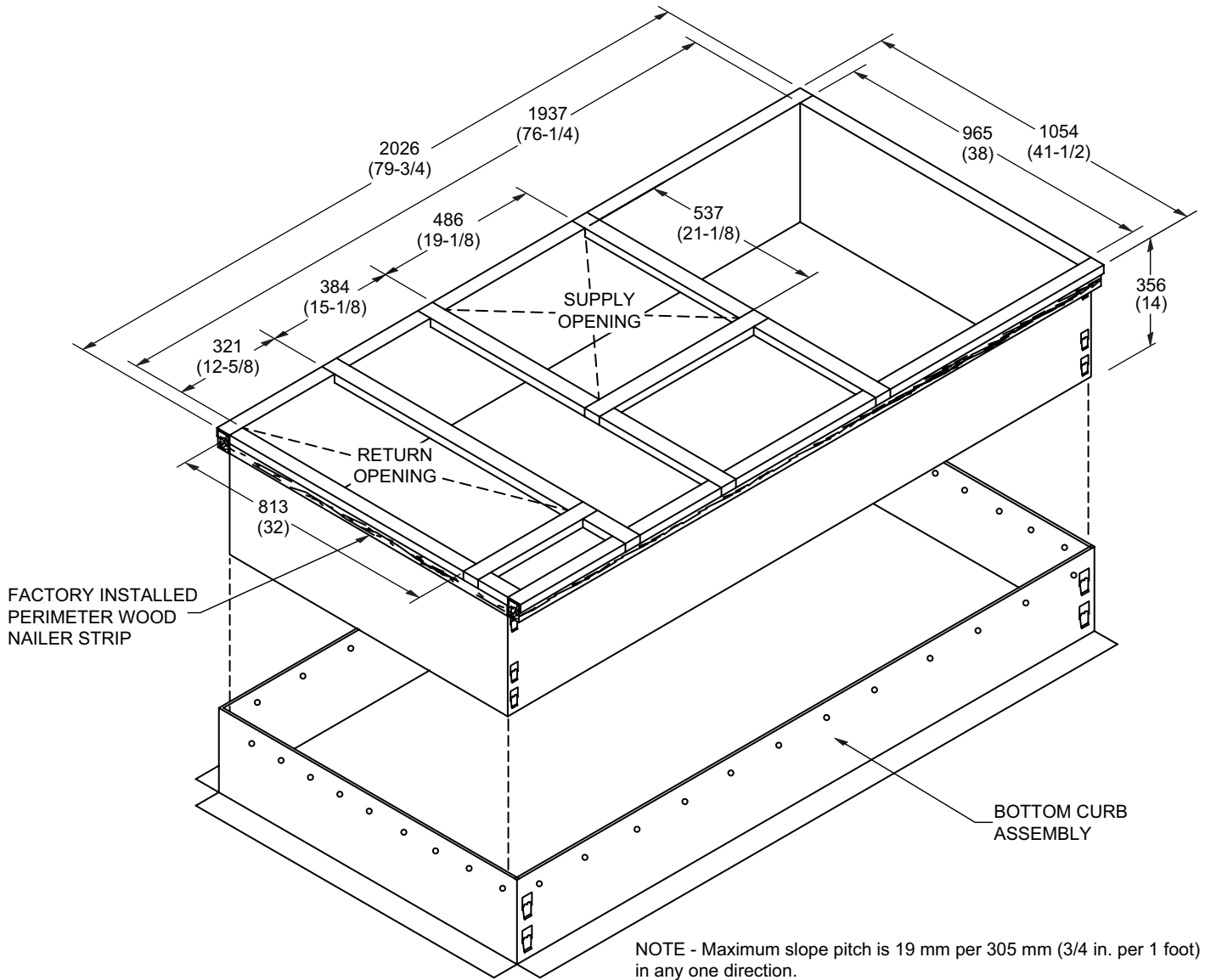

TYPICAL FLASHING DETAIL FOR ROOF CURB

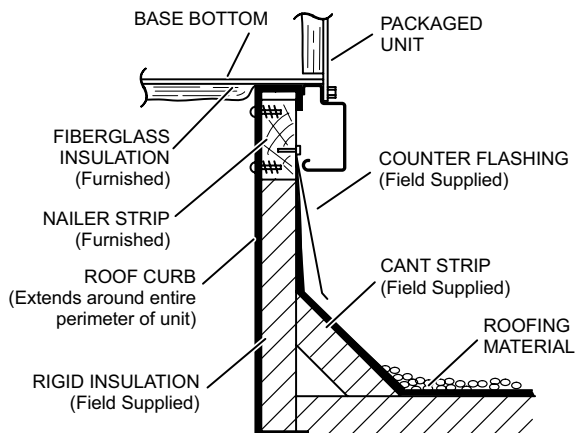

DETAIL ROOF CURB

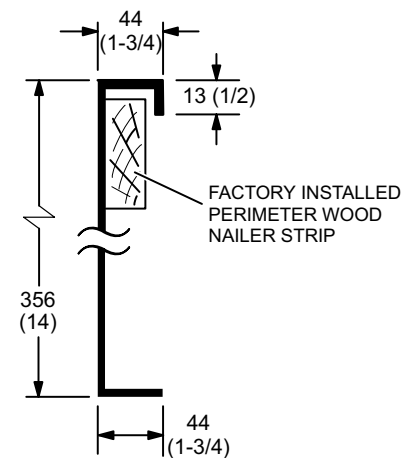

DIMENSIONS - ACCESSORIES

060H AND 074 MODELS - SHOWING OVERHANG ON SMALLER 2026 MM LENGTH ROOF CURBS
(Not Full Perimeter)

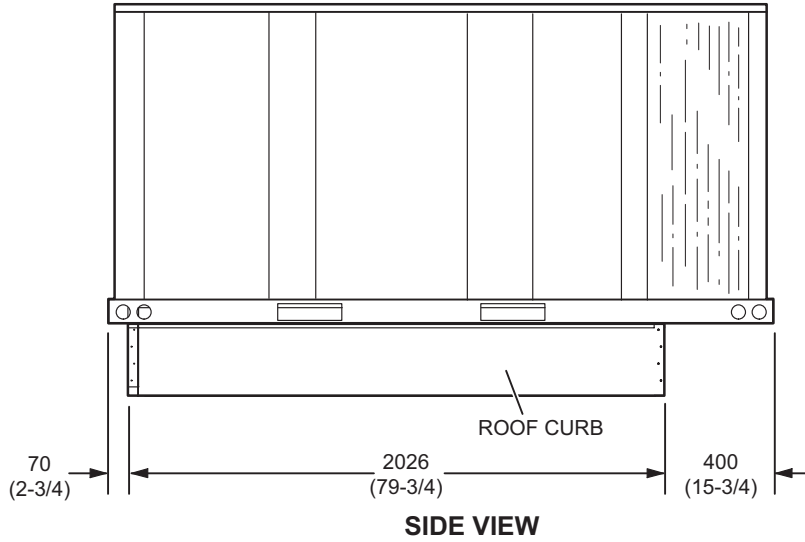

TRANSITIONS

T1TRAN10AN-1 - FOR 457 mm (18 inch) DUCT
T1TRAN20N-1 - FOR 508 mm (20 inch) DUCT

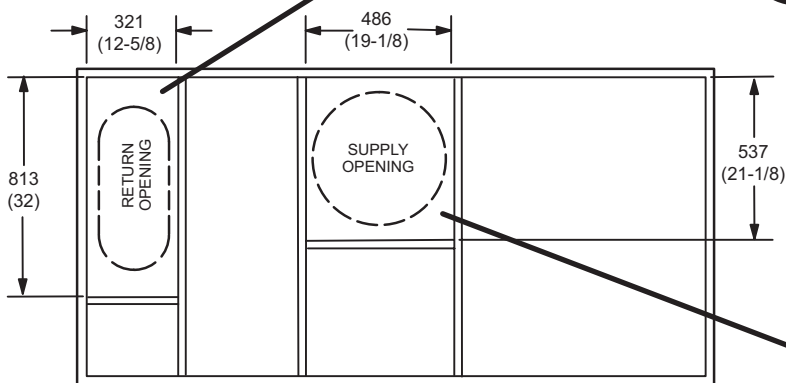
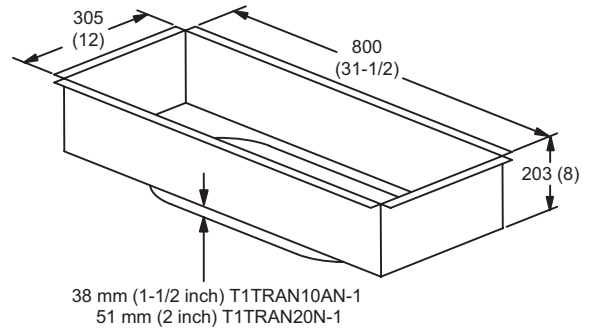

T1TRAN10AN-1 - FOR 457 mm (18 inch) DUCT
T1TRAN20N-1 - FOR 508 mm (20 inch) DUCT

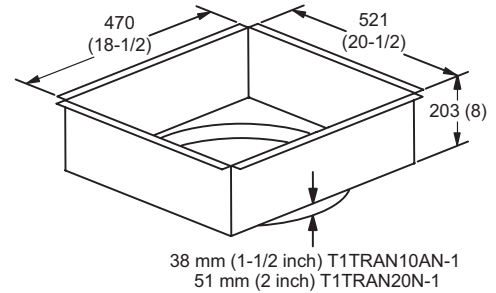

DIMENSIONS - ACCESSORIES

COMBINATION CEILING SUPPLY AND RETURN DIFFUSERS

STEP-DOWN CEILING DIFFUSER

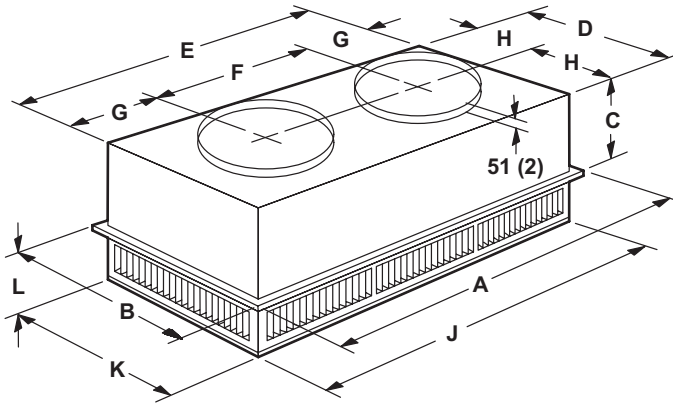

FLUSH CEILING DIFFUSER

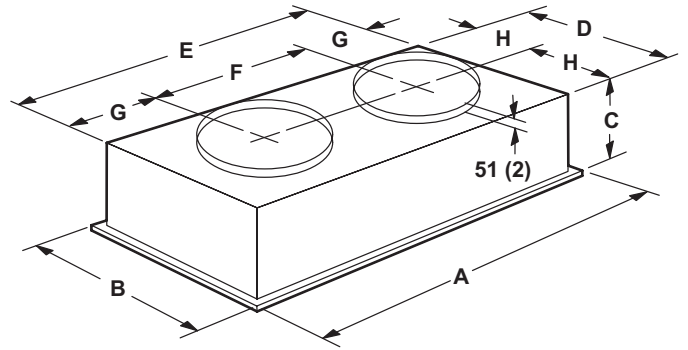

Model Number		RTD9-65S	RTD11-95S
A	mm	1159	1159
	in.	47-5/8	47-5/8
B	mm	600	752
	in.	23-5/8	29-5/8
C	mm	289	365
	in.	11-3/8	14-3/8
D	mm	546	699
	in.	21-1/2	27-1/2
E	mm	1156	1158
	in.	45-1/2	45-1/2
F	mm	572	572
	in.	22-1/2	22-1/2
G	mm	292	292
	in.	11-1/2	11-1/2
H	mm	273	349
	in.	10-3/4	13-3/4
J	mm	1156	1156
	in.	45-1/2	45-1/2
K	mm	546	699
	in.	21-1/2	27-1/2
L	mm	181	206
	in.	7-1/8	8-1/8
Duct Size	mm	457 round	508 round
	in.	18 round	20 round

Model Number		FD9-65S	FD11-95S
A	mm	1159	1159
	in.	47-5/8	47-5/8
B	mm	600	752
	in.	23-5/8	29-5/8
C	mm	343	422
	in.	13-1/2	16-5/8
D	mm	533	686
	in.	21	27
E	mm	1143	1143
	in.	45	45
F	mm	572	572
	in.	22-1/2	22-1/2
G	mm	286	286
	in.	11-1/4	11-1/4
H	mm	267	343
	in.	10-1/2	13-1/2
Duct Size	mm	457 round	508 round
	in.	18 round	20 round

REVISIONS

Sections	Description of Change
Options/Accessories	Catalog numbers revised for: Disconnects Economizers Gravity Exhaust Dampers Power Exhaust Single Enthalpy Smoke Detectors



Visit us at www.lennox.com

For the latest technical information, www.lennoxcommercial.com

Contact us at 1-800-4-LENNOX

NOTE - Due to Lennox' ongoing commitment to quality, Specifications, Ratings and Dimensions subject to change without notice and without incurring liability. Improper installation, adjustment, alteration, service or maintenance can cause property damage or personal injury. Installation and service must be performed by a qualified installer and servicing agency.

©2021 Lennox Industries, Inc.