

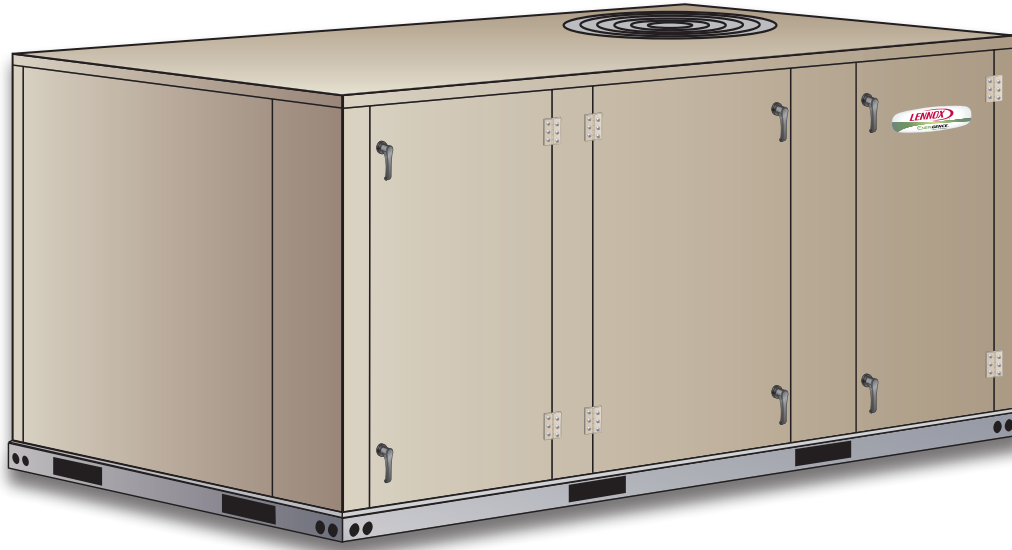

**COMMERCIAL**  
**PRODUCT SPECIFICATIONS**

Bulletin No. 490141  
 March 2021  
 Supersedes November 2019



SMARTWIRE™ SYSTEM



**10.6 to 21 kW (3 to 6 Ton)**  
**Net Cooling Capacity - 9.2 to 19.2 kW (31 400 to 65 500 Btuh)**  
**Optional Electric Heat - 5.7 to 23 kW**

**MODEL NUMBER IDENTIFICATION**

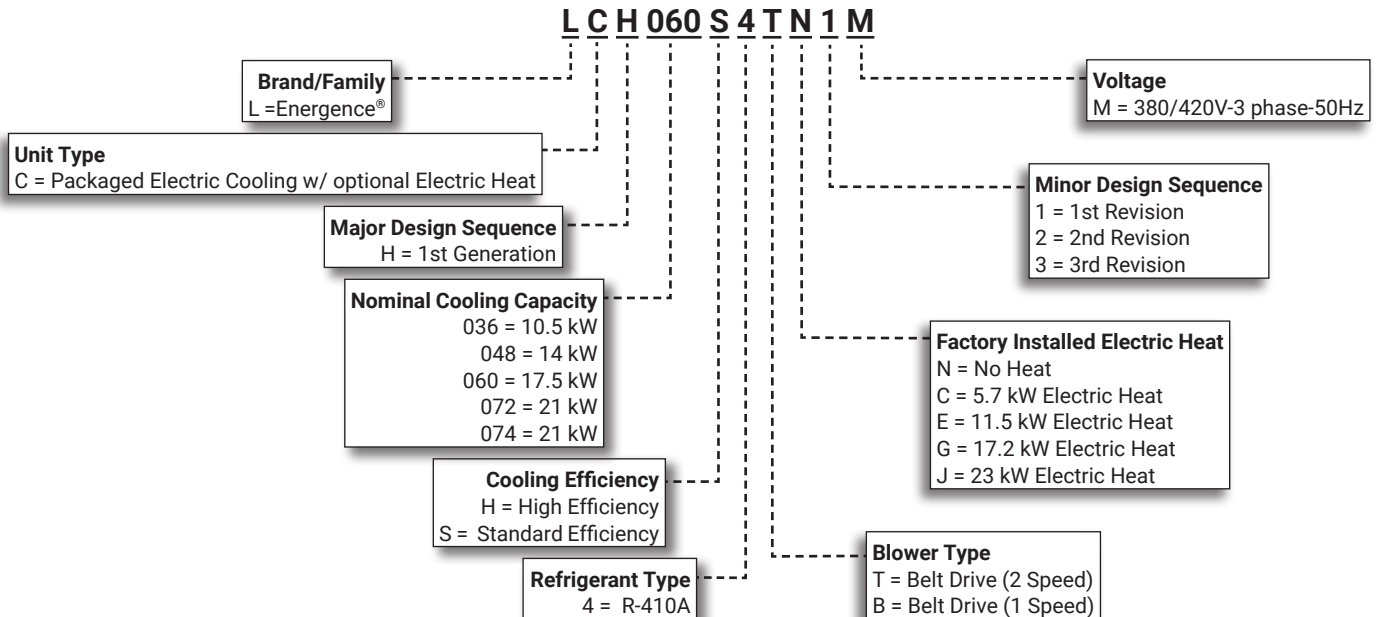

## FEATURE HIGHLIGHTS

Lennox' Energence® packaged rooftop unit product line was created to save energy with intelligence by offering some of the highest energy efficiency ratings available with a powerful, easy to use unit controller. This makes Energence® rooftop units perfect for business owners looking for a Heating, Ventilation, and Air Conditioning (HVAC) product with the lowest total cost of ownership.

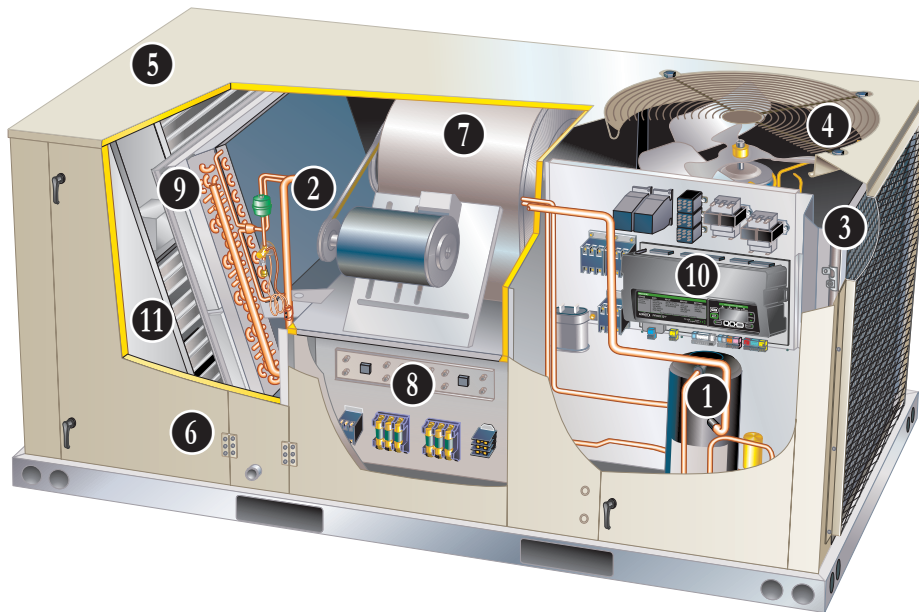

1. Two Stage Compressor
2. Filter/Drier
3. Lennox' Environ™ Coil System
4. Outdoor Coil Fan Motor
5. Heavy Gauge Steel Cabinet
6. Hinged Access Panels
7. Supply Air Blower
8. Electric Heat (option)
9. Air Filters
10. Prodigy® Control System
11. Economizer (option)

## CONTENTS

Blower Data . . . . .	28
Control System . . . . .	7
Cooling Ratings . . . . .	21
Dimensions - Accessories . . . . .	42
Dimensions - Unit . . . . .	41
Electrical Data . . . . .	38
Electric Heat Capacities . . . . .	38
Features And Benefits . . . . .	3
Humiditrol® Dehumidification System Option . . . . .	11
Humiditrol® Dehumidification System Ratings . . . . .	26
Optional Conventional Temperature Control Systems . . . . .	12
Options / Accessories . . . . .	17
Outdoor Sound Data . . . . .	39
Sequence Of Operation . . . . .	14
Specifications . . . . .	20
Unit Clearances . . . . .	39
Weight Data . . . . .	40

## PERFORMANCE/QUALITY AND CE MARK OPTION

### PERFORMANCE/QUALITY

- Cooling performance is rated at test conditions included in Air-Conditioning, Heating and Refrigeration Institute (AHRI) Standard 210/240 (036 thru 060) or 340/360 (072/074) while operating at rated voltage and air volumes
- Components bonded for grounding to meet safety standards for servicing required by Underwriters Laboratories (UL) and the International Electrotechnical Commission (IEC)
- International Organization for Standardization (ISO) 9001 Registered Manufacturing Quality System

### CE MARK OPTION

- The CE mark has been added to our rooftop product line as a configure to order (CTO) option
- Optional construction allows units to be sold into countries requiring CE marking for rooftop products
- CE marked units meet the requirements of the Machinery Directive 2006/42/EC, Low Voltage Directive 73/23/EEC, EMC Directive 89/336/EEC, and Gas Directive 90/396/EEC
- Declaration of conformity certificates will be provided for each CE marked unit on demand
- Key features of this option over and above standard product features are:
  - Touch-proof electrical components meeting the requirements of EN 60529
  - Branch circuits over 0.5 kW load have overcurrent protection
  - Rotary style/finger safe disconnect switch with locking handle prevents disconnect door from being opened with the power on
  - Padlock can be applied to lock the disconnect switch in the OFF position
  - The factory wiring has been redesigned for separation of high and low voltage circuits



## FEATURES AND BENEFITS

### COOLING SYSTEM

- Designed to maximize sensible and latent cooling performance at design conditions
- System can operate from -18°C to 52°C without any additional controls

#### R-410A Refrigerant

- Non-chlorine based
- Ozone friendly

#### 1 Two-Stage Compressor (10.5 to 17.5 kW and 21 kW 074 Models)

- Scroll compressors on all models for high performance, reliability, and quiet operation
  - Two-stage scroll compressors are furnished on 10.5 to 17.5 kW and 21 kW (074) models for increased part load efficiency
  - Single speed scroll furnished on 21 kW (072) models
- Resiliently mounted on rubber grommets for quiet operation

#### Compressor Crankcase Heater

- Protects against refrigerant migration that can occur during low ambient operation or during extended off cycles

#### Thermal Expansion Valve

- Ensures optimal performance throughout the application range
- Removable element head

#### 2 Filter/Drier

- High capacity filter/drier protects the system from dirt and moisture

#### High Pressure Switch

- Protects the compressor from overload conditions such as dirty condenser coils, blocked refrigerant flow, or loss of outdoor fan operation

#### Low Pressure Switch

- Protects the compressor from low pressure conditions such as low refrigerant charge, or low/no airflow

#### Freezestat

- Protects the evaporator coil from damaging ice build-up due to conditions such as low/no airflow, or low refrigerant charge

#### 3 Condenser Coil - Lennox' Environ™ Coil System

- Lightweight, all aluminum brazed fin construction
- Constructed of three components:
  - A flat extrusion tube
  - Fins in-between the flat extrusion tube
  - Two refrigerant manifolds

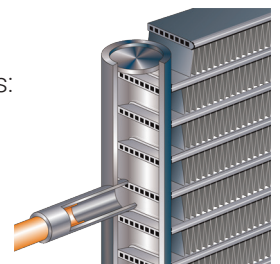

#### Environ™ Coil System Features:

- Improved heat transfer performance due to high primary surface area (flat tubes) versus secondary surface (fins)
- Smaller internal volume (reduced refrigerant charge)
- All aluminum construction
- Fewer brazed joints
- Compact design
- Easy maintenance/cleaning
- Face-split design
- Mounting brackets with rubber inserts

## FEATURES AND BENEFITS

### COOLING SYSTEM (continued)

#### Evaporator Coil

- Copper tube construction
- Enhanced rippled-edge aluminum fins
- Flared shoulder tubing connections
- Silver soldered construction
- Factory leak tested
- Cross row circuiting with rifled tubing

#### Condensate Drain Pan

- Plastic pan with positive slope
- Side or bottom drain connections
- Reversible to allow connection at back of unit

### 4 Outdoor Coil Fan Motor

- Thermal overload protected
- Totally enclosed
- Permanently lubricated sleeve bearings (036 and 048 models)
- Permanently lubricated ball bearings (060, 072 and 074 models)
- Shaft up
- Wire basket mount

#### Outdoor Coil Fan

- Polyvinyl chloride (PVC) coated fan guard furnished

### Required Selections

#### Cooling Capacity

- Specify nominal cooling capacity

### Options/Accessories

#### Factory Installed

##### Conventional Fin/Tube Condenser Coil (replaces Environ™ Coil System)

- Copper tube construction
- Enhanced rippled-edge aluminum fins
- Flared shoulder tubing connections
- Silver soldered construction

#### Service Valves

- Fully serviceable brass valves installed in discharge & liquid lines

**NOTE** - Not available for units equipped with Environ™ Coil System or Humiditrol Dehumidification option.

#### Factory or Field Installed

##### Condensate Drain Trap

- Available in copper or polyvinyl chloride (PVC)

**NOTE** - Factory installed option is shipped with the unit for field installation.

##### Drain Pan Overflow Switch

- Monitors condensate level in drain pan
- Shuts down unit if drain becomes clogged

### CABINET

### 5 Construction

- Heavy-gauge steel panels
- Full perimeter heavy-gauge galvanized steel base rail
- Base rails have rigging holes
- Three sides of the base rail have forklift slots
- Raised edges around duct and power entry openings in the bottom of the unit for water protection

#### Airflow Choice

- Units are shipped in downflow (vertical) return air flow configuration
- Can be field converted to horizontal air flow configuration without the need of a kit

#### Duct Flanges

- Provided for horizontal duct attachment

#### Power Entry

- Electrical lines can be brought through the unit base or through horizontal access knock-outs

#### Exterior Panels

- Constructed of heavy-gauge, galvanized steel
- Two-layer enamel paint finish

#### Insulation

- Fully insulated with non-hygroscopic fiberglass insulation (conditioned areas)
- Unit base is fully insulated
- Base insulation serves as an air seal to the roof curb, eliminating the need to add a seal during installation

### 6 Hinged Access Panels

- Tool-less access
- Filter section
- Blower/heating section
- Compressor/controls section
- Panel seals and quarter-turn latching handles provide a tight air and water seal

**NOTE** - 060/072/074 models include a filler panel for proper cabinet fit for optional accessories (Economizers, Power Exhaust, Outdoor Air Dampers and Barometric Relief Dampers).

### Required Selections

#### Airflow Configuration

- Specify downflow or horizontal

## FEATURES AND BENEFITS

### **CABINET (continued)**

#### Options/Accessories

#### **Factory Installed**

##### **Corrosion Protection**

- Completely flexible immersed coating
- Electrodeposited dry film process
- AST ElectroFin E-Coat
- Meets Mil Spec MIL-P-53084, ASTM B117 Standard Method Salt Spray Testing
- Indoor Corrosion Protection:
  - Coated coil
  - Coated reheat coil (Humiditrol®)
  - Painted blower housing
  - Painted base
- Outdoor Corrosion Protection:
  - Coated coil
  - Painted outdoor base

#### **Field Installed**

##### **Combination Coil/Hail Guards**

- Heavy gauge steel frame
- Painted to match cabinet
- Expanded metal mesh to protect the outdoor coil

### **BLOWER**

- A wide selection of supply air blower options are available to meet a variety of airflow requirements
- Overload protected
- Ball bearings
- Two-speed belt drive motors (low static/high static) available on 036, 048, 060 and 074 models in several different sizes to maximize air performance
- Single speed belt drive motor is available on 072 models

#### **7 Supply Air Blower**

- Forward curved blades
- Blower wheel statically and dynamically balanced
- Belt drive motors have adjustable pulley for speed change

#### **Ordering Information**

- Specify motor kW and drive kit number when base unit is ordered

#### Required Selections

- Order one drive kit, see Drive Kit Specifications Table

### **ELECTRICAL**

#### **SmartWire™ System**

- Keyed and color-coded wiring connectors prevent miswiring
- Wire coloring scheme is standardized across all models
- Each connection is intuitively labeled to make troubleshooting and servicing quick and easy

#### **Electrical Plugs**

- Positive connection electrical plugs are used to connect common accessories or maintenance parts for easy removal or installation

#### Options/Accessories

#### **Factory or Field Installed**

#### **8 Electric Heat**

- Electric heat is CE marked
- Helix wound nichrome elements
- Individual element limit controls
- Wiring harness
- Unit fuse block
- See Options / Accessories tables for ordering information

## FEATURES AND BENEFITS

### INDOOR AIR QUALITY

#### 9 Air Filters

- Disposable 51 mm filters furnished as standard

#### Options/Accessories

#### **Factory or Field Installed**

##### Healthy Climate® High Efficiency Air Filters

- Disposable MERV 8 or MERV 13 (Minimum Efficiency Reporting Value based on ASHRAE 52.2) efficiency 51 mm pleated filters

#### **Field Installed**

##### Healthy Climate® UVC Germicidal Lamps

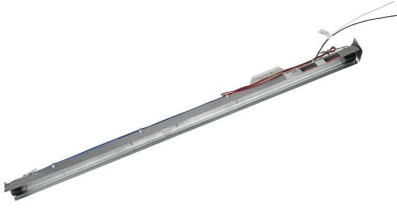

- Germicidal lamps emit ultra-violet (UV-C) energy, which has been proven to be effective in reducing microbes such as viruses, bacteria, yeasts, and molds
- This process either destroys the organism or controls its ability to reproduce
- UV-C energy greatly reduces the growth and proliferation of mold and other bioaerosols (bacteria and viruses) on illuminated surfaces (particularly coil and drain pan)
- Field installed in the blower/evaporator coil section
- Magnetic safety interlock terminates power when access panels are removed
- All necessary hardware for installation is included
- Lamps operate on 220V-1ph power supply

**NOTE** - Step-down transformer must be field supplied for field installation for 380/420V primary to 220V secondary.

##### Indoor Air Quality (CO<sub>2</sub>) Sensors

- Monitors CO<sub>2</sub> levels
- Reports to the Prodigy 2.0 unit controller, which adjusts economizer dampers as needed

##### Replacement Filter Media Kit With Frame

- Replaces existing pleated filter media
- Includes washable metal mesh screen and metal frame with clip for holding replaceable non-pleated filter

## CONTROL SYSTEM

### PRODIGY 2.0 UNIT CONTROLLER



**10** The Prodigy 2.0 unit controller is a microprocessor-based controller that provides flexible control of all unit functions.

#### Features:

- LCD Display
- Easy to read menu (4 lines x 20 character display)
- Buttons for menu navigation during setup and diagnostic
- Menu navigation LEDs for Data, Setup, Service, Settings
- Main Menu and Help Buttons for quick navigation to home screen and built-in help functions
- Scroll, Value Adjustment Select and Save Buttons
- Setup menu insures proper installation and simplified setup of the rooftop unit
- Profile setup copies key settings between units with the same configuration to reduce setup time
- USB port allows a technician to download and transfer unit information to help verify service was performed
- USB software updates on the Prodigy® Control System enhance functionality without the need to change components
- Unit Controller Software
- Unit self-test verifies individual critical component and system performance
- Economizer test function assures economizer is operating correctly
- Time Clock with Run-Time Information

#### Built-In Functions Include:

- Adjustable Blower On/Off Delay
- Built-in Control Parameter Defaults
- Compressor Time-Off Delay
- DDC Compatible
- Dirty Filter Switch Input
- Discharge Air Temperature Control
- Display/Sensor Readout
- Economizer Control Options  
(See Economizer / Exhaust Air / Outdoor Air sections)
- Fresh Air Tempering
- Over 100 diagnostic and status messages in English
- Exhaust Fan Control Modes for fresh air damper position
- Permanent Diagnostic Code Storage
- Field Adjustable Control Parameters (Over 200 settings)
- Indoor Air Quality Input (Demand Control Ventilation)
- Low Ambient Controls for cooling operation down to -17°C

- Gas Valve Time Delay Between First and Second Stage
- Minimum Compressor Run Time
- Network Capable  
(Can be daisy chained to other units or controls)
- Night Setback Mode
- Return Air Temperature Limit Control
- Safety Switch Input allows Controller to respond to a external safety switch trip
- Service Relay Output
- Smoke Alarm Mode has four choices (unit off, positive pressure, negative pressure, purge)
- Up to 2 heat/2 cool (standard Prodigy® unit controller thermostat input)
- Up to 3 cool with additional relay
- Up to 4 cool with room sensor or network operation
- “Strike Three” Protection
- Gas Reheat Control allows simultaneous heating and cooling operation for humidity control of process air applications such as supermarkets
- On Demand Dehumidification monitors and controls condenser hot gas reheat operation with Humiditrol® dehumidification option
- Thermostat Bounce Delay
- Warm Up Mode Delay
- LED Indicators
- PC Interface connects the Prodigy 2.0 unit controller to a PC with the Lennox Unit Controller Software
- Room Sensor Operation controls temperature

**NOTE** - Prodigy® Control System features vary with the type of rooftop unit in which the control is installed.

**NOTE** - See separate Prodigy® Control System Product Specifications Bulletin for additional information..

## CONTROL SYSTEM

### PRODIGY 2.0 UNIT CONTROLLER (continued)

#### Options / Accessories

#### **Factory or Field Installed**

##### Blower Proving Switch

- Monitors blower operation, shuts down unit if blower fails

##### Dirty Filter Switch

- Senses static pressure increase indicating dirty filter condition

#### Control Options

#### **Factory or Field Installed**

##### Fresh Air Tempering

- Used in applications with high outside air requirements
- Controller energizes the first stage heat as needed to maintain a minimum supply air temperature for comfort, regardless of the thermostat demand
- When ordered as a factory option, sensor ships with the unit for field installation

##### Smoke Detector

- Photoelectric type
- Installed in supply air section, return air section or both sections
- Available with power board and single sensor (supply or return) or power board and two sensors (supply and return)
- Power board located in unit control compartment

##### Interoperability via BACnet® or LonTalk® Protocols

- Communication compatible with third-party automation systems that support the BACnet Application Specific Controller device profile, LonMark® Space Comfort Controller functional profile, or LonMark Discharge Air Controller functional profile

#### **Commercial Control Systems**

##### After-Market DDC

- Novar® Unit Controller and options

##### Thermostats

- Control system and thermostat options
- After-Market unit controller options

#### **Field Installed**

##### General Purpose Control Kit

- Plug-in control provides additional analog and digital inputs/outputs for field installed options

##### Humidity Sensor Kit

- Humidity sensor required with factory installed Humiditrol® Dehumidification Option or Supermarket reheat field selectable option

## OPTIONS / ACCESSORIES

### ECONOMIZER

- 11 Economizer operation is set and controlled by the Prodigy 2.0 Unit Controller

- Simple plug-in connections from Economizer to unit controller for easy installation

**NOTE** - Optional sensors may be used instead of unit sensors to determine whether outdoor air is suitable for free cooling.

#### **Factory or Field Installed**

##### High Performance Economizer

- Combination Outdoor Air Hood is furnished
- Factory installed Economizer can be ordered with three exhaust options:

1. Barometric Relief Dampers
2. Power Exhaust Fan

**NOTE** - See Power Exhaust Fan section for additional requirements.

3. No Exhaust

- Field installed Economizer includes Barometric Relief Dampers with Combination Hood
- Barometric Relief Dampers allow relief of excess air
- Dampers prevent blow back and outdoor air infiltration during off cycle
- Bird screen furnished

**NOTE** - Barometric Relief Dampers are required when Economizer is factory installed with field or factory installed Power Exhaust Fan option. See Power Exhaust Fan section and Options/Accessories table.

- Demand Control Ventilation (DCV) ready using optional CO<sub>2</sub> sensors

**NOTE** - Horizontal Economizer Conversion kit is available for field installation.

**NOTE** - Horizontal Barometric Dampers are required for horizontal Economizer applications and must be ordered separately.

- Gear-driven action
- High torque 24-volt fully-modulating spring return damper motor
- Return air and outdoor air dampers
- Plug-in connections to unit
- Nylon bearings
- Enhanced thermoplastic vulcanizate (TPV) blade edge seals
- Flexible stainless steel jamb seals

**NOTE** - Refer to Installation Instructions for complete setup information.



## OPTIONS / ACCESSORIES

### **ECONOMIZER (continued)**

#### **Factory or Field Installed**

##### **Differential Sensible Control**

- Factory setting
- Uses outdoor air and return air sensors that are furnished with the unit
- The Prodigy 2.0 Unit Controller compares outdoor air temperature and return air
- Engages the economizer when the outdoor air temperature is below the configured setpoint and cooler than return air

**NOTE** - Differential Sensible Control can be configured in the field to provide Offset Differential Sensible Control or Single Sensible Control.

**NOTE** - In Offset Differential Sensible Control mode, the economizer is enabled if the temperature differential (offset) between outdoor air and return air reaches the configured setpoint. In Single Sensible Control mode, the economizer is enabled when outdoor air temperature falls below the configured setpoint.

##### **Global Control**

- Unit controller communicates with a DDC system with one global sensor (enthalpy or sensible)
- Determines whether outside air is suitable for free cooling on all units connected to the control system
- Sensor must be field provided

##### **Single Enthalpy Temperature Control**

- Outdoor air enthalpy sensor enables Economizer if the outdoor enthalpy is less than the setpoint of the control

##### **Differential Enthalpy Control**

- Order two Single Enthalpy Controls:
  - One is field installed in the return air section
  - One is installed in the outdoor air section
- Allows the economizer control to select between outdoor air or return air, whichever has lower enthalpy

#### **Field Installed**

##### **Building Pressure Control**

- Maintains constant building pressure level
- Includes a static pressure transducer and outdoor static pressure assembly
- Includes a static pressure transducer and outdoor static pressure assembly
- Using differential pressure information between the outdoor air and the building air, the Prodigy 2.0 unit controller changes the economizer position to help maintain a constant building pressure

**NOTE** - Not available with Demand Control Ventilation (CO<sub>2</sub> Sensor).

##### **Horizontal Barometric Relief Dampers**

- For use when unit is configured for horizontal applications with an Economizer
- Allows relief of excess air
- Blade type dampers prevent blow back and outdoor air infiltration during off cycle
- Field installed in return air duct
- Exhaust hood with bird screen furnished

**NOTE** - Requires Horizontal Economizer Conversion Kit.

##### **Horizontal Economizer Conversion Kit**

- Insulated panel covers the bottom return air opening on the unit base to convert downflow Economizer to horizontal air flow

### **EXHAUST**

#### **Factory or Field Installed**

##### **Power Exhaust Fan**

- Installs internally for downflow applications with economizer option
- Provides exhaust air pressure relief
- Interlocked to run when supply air blower is operating, fan runs when outdoor air dampers are 50% open (adjustable)
- Motor is overload protected
- 406 mm diameter fan
- 4 fan blades
- 0.25 kW motor

**NOTE** - If Power Exhaust is field installed with a factory installed Economizer, the Economizer must be ordered with No Exhaust option. Barometric Relief Dampers must also be ordered separately for field installation.

**NOTE** - If Power Exhaust is factory installed with a factory installed Economizer, Barometric Relief Dampers must also be ordered separately for field installation.

### **OUTDOOR AIR**

#### **Factory or Field Installed**

##### **Outdoor Air Dampers - Downflow or Horizontal**

- Single blade damper
- 0 to 25% (fixed) outdoor air adjustable; installs in unit
- Automatic model features fully modulating spring return damper motor with plug-in connection
- Manual model features a slide damper
- Maximum mixed air temperature in cooling mode: 38°C
- Outdoor Air Hood is furnished

## OPTIONS / ACCESSORIES

### **ROOF CURBS**

- Nailer strip furnished
- Mates to unit
- US National Roofing Contractors Approved
- Shipped knocked down

### **Hybrid Roof Curbs**

- Downflow
- Roof curb can be assembled using interlocking tabs to fasten corners together
- No tools required
- Curb can also be fastened together with furnished hardware
- Available in 203, 356, 457, and 610 mm heights

### **Adjustable Pitch Curb**

- Downflow
- Fully adjustable pitch curb provides a level platform for rooftop units allowing flexible installations on roofs with uneven or sloped angles
- Maximum slope is 19 mm per 300 mm in any direction
- Uses interlocking tabs to fasten corners together; no tools required
- Hardware is furnished to connect upper curb with lower curb
- Available in 356 mm height

### **Adaptor Curbs (not shown)**

- Curbs are regionally sourced
- Dimensions will vary based upon the source

**NOTE** - Contact your local sales representative for a detailed cut sheet with applicable dimensions.

### **CEILING DIFFUSERS**

#### **Ceiling Diffusers (Flush or Step-Down)**

- White powder coat finish on diffuser face and grilles
- Insulated UL listed duct liner
- Diffuser box has collars for duct connection
- Step-down diffusers have double deflection blades
- Flush diffusers have fixed blades
- Provisions for suspending
- Internally sealed to prevent recirculation
- Removable return air grille
- Adapts to T-bar ceiling grids or plaster ceilings

#### **Transitions (Supply and Return)**

- Used with diffusers
- Installs in roof curb
- Galvanized steel construction
- Flanges furnished for duct connection to diffusers
- Fully insulated

## HUMIDITROL® DEHUMIDIFICATION SYSTEM OPTION

### OVERVIEW

- Factory installed option designed to control humidity
- Provides dehumidification on demand using American Society of Heating, Refrigeration and Air Conditioning Engineers (ASHRAE) 90.1 recommended method for comfort conditioning humidity control
- Unit comes equipped with one row reheat coil, solenoid valve and humidity controller
- A humidity sensor is required and must be located in the occupied space

**NOTE** - Remote Mounted Humidity Sensor Kit is required for field installation.

- Humidity sensor provides input to the Unit Controller, which is used to control activation of the dehumidification operation
- Reheat controls are located in the compressor control section of the unit for easy access

### BENEFITS

- Improves indoor air quality
- Helps prevent damage due to high humidity levels
- Improves comfort levels by reducing space humidity levels

### OPERATION

#### No Dehumidification Demand

- The unit will operate conventionally whenever there is a demand for cooling or heating and no dehumidification demand
- Free cooling is only permitted when there is no demand for dehumidification

#### Dehumidification Demand Only

- The Unit Controller is factory set at 60% relative humidity setpoint and can be adjusted at the Unit Controller or with optional Unit Controller Software
- Reheat operation will initiate on a dehumidification demand and does not require a cooling demand
- The unit will operate in the dehumidification mode until the relative humidity of the conditioned space is below the setpoint
- The reheat coil is sized to provide 20°C to 24°C supply air during reheat operation
- This reduces sensible cooling capacity and extends compressor run time to control humidity when the cooling load is low
- A solenoid valve diverts hot gas from the compressor to the reheat coil
- The cooled and dehumidified air from the evaporator is reheated as it passes through the reheat coil

- The de-superheated and partially condensed refrigerant continues to the outdoor condenser coil where condensing is completed
- Unit will continue to operate in this mode until the dehumidification demand is satisfied

**NOTE** - See Sequence of Operation for additional information.

#### Dehumidification and Cooling Demand (Thermostat/Room Sensor Application)

##### Two-stage compressor models (036, 048, 060, 074)

- If both a dehumidification and a 1st stage cooling demand occur, the system will operate in the full cooling mode at first stage indoor air flow. If a 2nd stage cooling demand occurs along with a dehumidification demand, the system operates in full cooling mode at full cooling airflow until the 2nd stage cooling demand is satisfied. Then the system will revert to the dehumidification mode if a dehumidification mode demand is present

##### Single speed compressor model (072H)

- If both a dehumidification and a cooling demand occur, the system will operate in cooling until the cooling demand is satisfied; then the system will start the dehumidification mode

### Options / Accessories

#### Humidity Sensor Kit

- Remote mounted dehumidistat for factory installed Humiditrol® option or Supermarket reheat field selectable option

**NOTE** - A thermostat with a dehumidification output or a DDC controller with an isolated output can be used instead.

TYPICAL DEHUMIDIFICATION SCHEMATIC

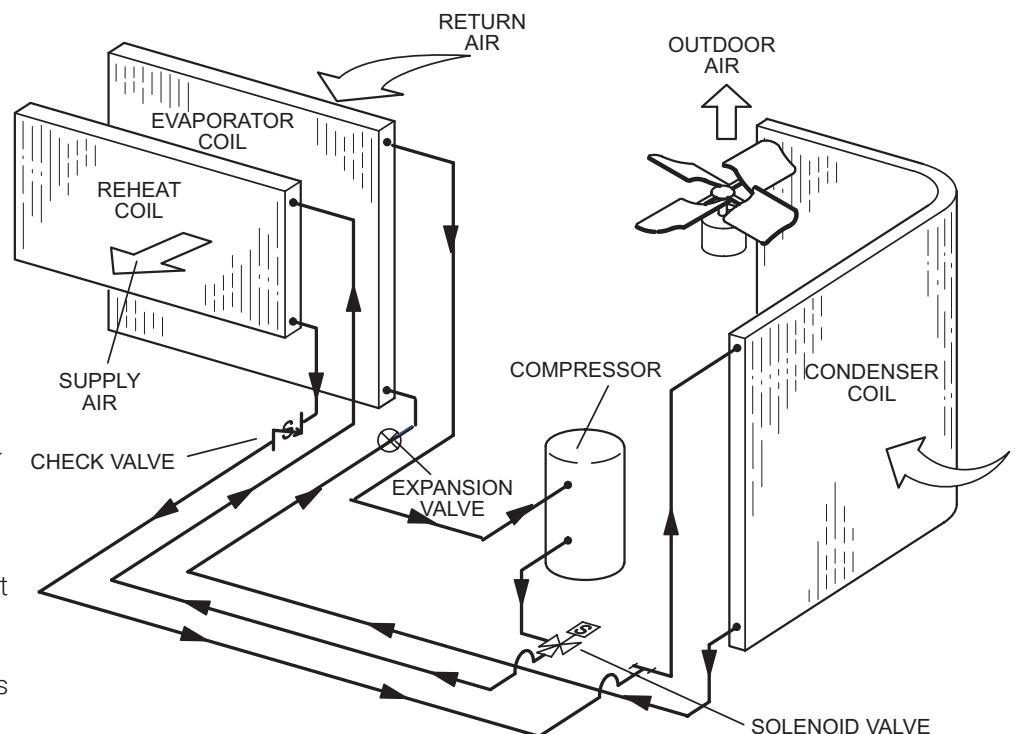

## OPTIONAL CONVENTIONAL TEMPERATURE CONTROL SYSTEMS

### ComfortSense® 8500 Commercial 7-Day Programmable Thermostat

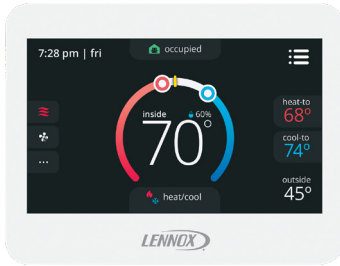

- Fully Communicating Sensor
- Full Color Touchscreen Interface
- Variable Speed System Control (On Compatible Units)
- Up To 4 Heat / 4 Cool
- Built-In Sensors For Temperature, Humidity And Optional CO<sub>2</sub>
- Remote Sensor Options For Occupancy, Temperature
- BACnet Capable Options
- 5-2 or 7-Day Scheduling
- Smooth Setback Recovery
- Heat/Cool Auto-Changeover
- Four-Wire Installation
- FDD, ASHRAE, IECC Compliant

### ComfortSense® 7500 Commercial 7-Day Programmable Thermostat



- Premium Universal Thermostat
- Full Color Touchscreen Interface
- Up To 4 Heat / 4 Cool
- Built-In Sensors For Temperature and Humidity
- Remote Sensors Options For Temperature, Discharge Air, Outdoor Air
- 5-2 or 7-Day Scheduling
- Smooth Setback Recovery
- Heat/Cool Auto-Changeover
- FDD, ASHRAE, IECC Compliant

### ComfortSense® 3000 Commercial 5-2 Day Programmable Thermostat



- Conventional Multi-Stage Thermostat
- Intuitive Display
- Push-Button Operation
- Up To 2 Heat / 2 Cool
- Built-In Temperature Sensor
- Remote Temperature Sensing
- Up to 5-2 Day Scheduling
- Smooth Setback Recovery
- Heat/Cool Auto-changeover

### Wired Room Sensor (LCS-5030)



- Simple Push-Button Override
- Variable Speed System Control (On Compatible Units)
- Up To 4 Heat / 4 Cool
- Built-In Temperature and Humidity Sensors
- AA Battery / 24VAC Powered
- SBUS Wired Operation
- Automatic Sensor Averaging
- Locking Hex Screw

## OPTIONAL CONVENTIONAL TEMPERATURE CONTROL SYSTEMS

Description	Catalog No.
<b>ComfortSense® 8500 Commercial 7 Day Programmable Thermostat</b>	
CS8500 7-Day Thermostat	No CO <sub>2</sub> Sensing <b>17G75</b>
	With CO <sub>2</sub> Sensing <b>17G76</b>
Sensors/Accessories	<sup>1</sup> Remote non-adjustable wall-mount 10k <b>47W37</b>
	<sup>1</sup> Remote non-adjustable wall-mount 11k <b>94L61</b>
<b>Sysbus Network Cable (Yellow) for ComfortSense 8500 and LCS-5030 Wired Room Sensor</b>	
Twisted pair 100% shielded communication cable, Red and Black	500 ft. box <b>27M19</b>
22 AWG, yellow jacket, rated at 75°C, 300V, Plenum rated	1000 ft. box <b>94L63</b>
Insulation - Low smoke PVC, NEC, CMP	2500 ft. roll <b>68M25</b>
<b>ComfortSense® 7500 Commercial 7-Day Programmable Thermostat</b>	
CS7500 7-Day Thermostat	<b>17G74</b>
Sensors/Accessories	<sup>2</sup> Remote non-adjustable wall-mount 20k <b>47W36</b>
	<sup>2</sup> Remote non-adjustable wall-mount 10k <b>47W37</b>
	Remote non-adjustable discharge air (duct mount) <b>19L22</b>
	Outdoor temperature sensor <b>X2658</b>
<b>ComfortSense® 3000 Commercial 5-2 Day Programmable Thermostat</b>	
CS3000 5-2 Day Thermostat	<b>11Y05</b>
Sensors/Accessories	Remote non-adjustable wall mount 10k averaging <b>47W37</b>
	Thermostat wall mounting plate <b>X2659</b>
<b>ComfortSense® Non-Programmable Thermostat</b>	
CS3000 Non-Programmable Thermostat	<b>51M32</b>
<b>Universal Thermostat Guard with Lock (clear)</b>	
	Inside Dimensions (H x W) 5 7/8 x 8 3/8 in. <b>39P21</b>
<b>Wired Room Sensor</b>	
LCS-5030 Wired Room Sensor	<b>21L07</b>

<sup>1</sup> Up to nine of the same type remote temperature sensors can be connected in parallel.

<sup>2</sup> Remote wall-mount sensors can be applied in any of the following combinations:

One Sensor - (1) 47W36, Two Sensors - (2) 47W37, Three Sensors - (2) 47W36 and (1) 47W37

Four Sensors - (4) 47W36, Five Sensors - (3) 47W36 and (2) 47W37

**Objective:** Outline the unit functions as a result of room thermostat or zone sensor demands.

**Given:** When economizer is present, it will function as initial part of the unit cooling system. When not present, unit will function as if outdoor ambient is high and sensed as not suitable.

**BELT DRIVE SYSTEM OPERATION (036 THROUGH 060 AND 074 MODELS):**

**Modulating Outdoor Air Damper:**

Damper minimum positions #1 and 2 are adjusted during unit setup to provide minimum fresh air requirements at the indicated supply fan speeds per American Society of Heating, Refrigeration, and Air Conditioning Engineers (ASHRAE) 62.1.

- Supply fan is off and the outdoor air damper is closed
- Supply fan is on low speed and the outdoor air damper is at minimum position 1
- Supply fan is on high speed and the outdoor air damper is at minimum position 2

**<sup>1</sup> Unit Features an Economizer and Outdoor Air is Suitable**

Cooling - Thermostat or Zone Sensor Mode (Up to 3 stages Y1, Y2, Y3)

**Y1 Demand:**

Compressor is off, supply fan is on low speed, economizer modulates (minimum to maximum open position) to maintain 13°C supply air temperature (default unit controller setting)

After 5 minutes (default unit controller setting), supply fan switches to high speed. Economizer continues modulating with supply fan on high speed to maintain 13°C supply air temperature

**Y2 Demand:**

Compressor is off, supply fan is on high speed, and economizer modulates to maintain 13°C supply air temperature

Economizer opens to maximum. If economizer stays at maximum open for 3 minutes (default unit controller setting) compressor is energized and operates at first stage while supply fan stays on high speed

<sup>1</sup> Outdoor air suitability is determined by the energy state of outdoor ambient (enthalpy or sensible) and its ability to achieve the desired free cooling effects. Outdoor air suitability can also be determined by a third party controller and provided to the rooftop unit (RTU) via a network connection.

**Y3 Demand:**

Economizer is at maximum open and compressor operates at first stage. If economizer stays at maximum open for 3 minutes (default unit controller setting) compressor switches to second stage operation while supply fan stays on high speed

**Unit Does Not Feature an Economizer (or Outdoor Air Is Not Suitable)**

Cooling - Thermostat or Zone Sensor (Up to 2 stages Y1, Y2)

**Y1 Demand:**

Compressor operates at first stage and supply fan operates at low speed

**Y2 Demand:**

Compressor operates at second stage and supply fan operates at high speed

(Continued on Next Page)

**BELT DRIVE SYSTEM OPERATION (036 THROUGH 060 AND 074 MODELS) (CONTINUED):****Dehumidification Mode (economizer free cooling is locked out):**

Unit features the Humiditrol® dehumidification system

**No Y1, Y2 Demand but a call for dehumidification:**

Compressor operates at second stage, supply fan operates at low speed, and the reheat valve is energized

**Y1 Demand:**

Compressor operates at second stage, outdoor fan operates at high speed, supply fan operates at low speed and the reheat valve is de-energized

**Y2 Demand:**

Compressor operates at second stage, supply fan operates at high speed, and the reheat valve is de-energized

**Heating Mode: Thermostat or Zone Sensor (1 stage W1)****W1 Demand:**

Electric Heat is energized and the supply fan operates at high speed

**SINGLE STAGE UNIT OPERATION (072)****Modulating Outdoor Air Damper:**

Damper minimum positions are adjusted during unit setup to provide minimum fresh air requirements at the indicated supply fan speeds per American Society of Heating, Refrigeration, and Air Conditioning Engineers (ASHRAE) 62.1.

- Supply fan is off and the outdoor air damper is closed
- Supply fan is on and the outdoor air damper is at minimum position

**<sup>1</sup> Unit Features an Economizer and Outdoor Air is Suitable**

Cooling - Thermostat or Zone Sensor (Up to 2 stages Y1, Y2)

**Y1 Demand:**

Compressor is off, supply fan is on, economizer modulates (minimum to maximum open position) to maintain 13°C supply air temperature (default unit controller setting)

**Y2 Demand:**

Economizer goes to maximum open position and if the damper stays open for three minutes (default unit controller setting) the compressor is energized

**Unit Does Not Feature an Economizer (or outdoor air is not suitable)**

Cooling - Thermostat or Zone Sensor (Up to 1 stage Y1)

**Y1 Demand:**

Compressor is operating and supply fan is on

**Dehumidification Mode (economizer free cooling is locked out):****Unit Features the Humiditrol® Dehumidification System****No Y1 Demand but a call for dehumidification:**

Compressor is operating, supply fan is on, and the reheat valve is energized

**Y1 Demand:**

Compressor is operating, supply fan is on, and the reheat valve is de-energized

**Y2 Demand:**

Compressor is operating, supply fan is on, and the reheat valve is de-energized

**Heating Mode: Thermostat or Zone Sensor (1 stage W1)****W1 Demand:**

Electric Heat is energized and the supply fan operates at high speed



## OPTIONS / ACCESSORIES

Item	Model Number	Catalog Number	Unit				
			036	048	060	072	074
<b>CE MARK</b>							
CE Marked Unit		Factory	O	O	O	O	O
<b>COOLING SYSTEM</b>							
Condensate Drain Trap	Polyvinyl Chloride (PVC) - C1TRAP20AD2	<b>22H54</b>	OX	OX	OX	OX	OX
	Copper - C1TRAP10AD2	<b>76W27</b>	OX	OX	OX	OX	OX
Drain Pan Overflow Switch	E1SNSR71AD1	<b>21Z07</b>	OX	OX	OX	OX	OX
Efficiency		Standard	O	O	O		
		High	O	O	O	O	O
Service valves (not for Environ™ Coil System or Humiditrol® equipped units)		Factory	O	O	O	O	O
<b>BLOWER - SUPPLY AIR</b>							
Motors	Belt Drive - 0.47 kW (2 Speed)	Factory	O	O			
	Belt Drive - 0.62 kW (2 Speed)	Factory	O		O		
	Belt Drive - 1.24 kW (2 Speed)	Factory		O	O		O
	Belt Drive - 1.5 kW Standard Efficiency	Factory				O	
Drive Kits See Blower Data Tables for selection	Kit A01 - T1DRKT001-1 - 374-842 rev/min	Factory	O				
	Kit A02 - T1DRKT002-1 - 414-931 rev/min	Factory		O			
	Kit A03 - T1DRKT003-1 - 463-1042 rev/min	Factory			O		
	Kit A05 - T1DRKT005-1 - 498-1122 rev/min	Factory	O				
	Kit A06 - T1DRKT006-1 - 595-1191 rev/min	Factory		O			
	Kit A07 - T1DRKT007-1 - 673-1290 rev/min	Factory			O		
	Kit AA02 - T1DRKT002AP1 - 527-729 rev/min	Factory				O	
	Kit AA03 - T1DRKT003AP1 - 665-921 rev/min	Factory				O	O
	Kit AA04 - T1DRKT004AP1 - 768-1023 rev/min	Factory				O	O
<b>CABINET</b>							
Combination Coil/Hail Guards	C1GARD51A-1	<b>13R98</b>	X	X			
	C1GARD51AT1	<b>13T03</b>			X	X	X
Corrosion Protection (indoor coil / outdoor coil)		Factory	O	O	O	O	O
<b>CONTROLS</b>							
Blower Proving Switch	C1SNSR35FF1	<b>21Z10</b>	OX	OX	OX	OX	OX
Commercial Controls	Novar® LSE	Factory	O	O	O	O	O
	Novar 2051 - E0CTRL30A1	<b>64W72</b>	OX	OX	OX	OX	OX
	Prodigy® Control System - BACnet® Module - C0CTRL60AE1L	<b>59W51</b>	OX	OX	OX	OX	OX
	Prodigy® Control System - LonTalk® Module - C0CTRL65FF1	<b>54W27</b>	OX	OX	OX	OX	OX
Dirty Filter Switch	E1SNSR55AP1	<b>53W66</b>	OX	OX	OX	OX	OX
General Purpose Control Kit	E1GPBK30C1	<b>13J78</b>	X	X	X	X	X
Fresh Air Tempering	C1SNSR75AD1	<b>21Z08</b>	OX	OX	OX	OX	OX
Smoke Detector - Supply or Return (Power board and one sensor)	C1SNSR44AP1	<b>21Z11</b>	OX	OX	OX	OX	OX
Smoke Detector - Supply and Return (Power board and two sensors)	C1SNSR43AP1	<b>21Z12</b>	OX	OX	OX	OX	OX
<b>ELECTRICAL</b>							
Voltage 50 hz with neutral (No neutral on CE marked models)	380/420V - 3 phase	Factory	O	O	O	O	O

NOTE - Catalog and model numbers shown are for ordering field installed accessories.

OX - Configure To Order (Factory Installed) or Field Installed

O = Configure To Order (Factory Installed)

X = Field Installed

## OPTIONS / ACCESSORIES

Item	Model Number	Catalog Number	Unit				
			036	048	060	072	074
<b><sup>1</sup> ELECTRIC HEAT</b>							
5.7 kW	380/420V-3ph - E1EH0057AN1M	<b>67W88</b>	OX	OX	OX	OX	OX
11.5 kW	380/420V-3ph - E1EH0115AN1M	<b>67W89</b>	OX	OX	OX	OX	OX
17.2 kW	380/420V-3ph - E1EH0172N-1M	<b>67W90</b>			OX	OX	OX
23 kW	380/420V-3ph - E1EH0230N-1M	<b>67W91</b>				OX	OX
<b>ECONOMIZER</b>							
<b>High Performance Economizer With Outdoor Air Hood (Sensible Control)</b>							
High Performance Economizer - Includes Barometric Relief Dampers and Exhaust Hood	E1ECON17A-2	<b>20H48</b>	OX	OX	OX	OX	OX
<b>Economizer Accessories</b>							
Horizontal Economizer Conversion Kit	T1HECK00AN1	<b>17W45</b>	X	X	X	X	X
<b>Economizer Controls</b>							
Differential Enthalpy	Order 2 - C1SNSR64FF1	<b>21Z09</b>	OX	OX	OX	OX	OX
Sensible Control	Sensor is Furnished	Factory	O	O	O	O	O
Single Enthalpy	C1SNSR64FF1	<b>21Z09</b>	OX	OX	OX	OX	OX
Global Control	Sensor Field Provided	Factory	O	O	O	O	O
Building Pressure Control	E1GPBK20C1	<b>13J77</b>	X	X	X	X	X
<b>POWER EXHAUST FAN (DOWNFLOW ONLY)</b>							
Standard Static	380/420V-3ph - C1PWRE10A-1M	<b>21Z16</b>	OX	OX	OX	OX	OX
<i>NOTE - Factory installed Power Exhaust Fan requires "Barometric Relief Dampers for Power Exhaust Kit" for field installation. See below.</i>							
<b>BAROMETRIC RELIEF</b>							
<sup>2</sup> Barometric Relief Dampers for Power Exhaust Kit	C1DAMP50A-3-	<b>21Z21</b>	X	X	X	X	X
<sup>3</sup> Horizontal Barometric Relief Dampers With Exhaust Hood	LAGEDH03/15-2	<b>19F01</b>	X	X	X	X	X
<b>OUTDOOR AIR</b>							
<b>Outdoor Air Dampers With Outdoor Air Hood</b>							
Motorized	C1DAMP21A-1	<b>15D17</b>	OX	OX	OX	OX	OX
Manual	C1DAMP11A-2	<b>15D18</b>	OX	OX	OX	OX	OX
<b>HUMIDITROL® CONDENSER REHEAT OPTION</b>							
Humiditrol®		Factory	O	O	O	O	O
Humidity Sensor Kit, Remote mounted (required)	COSNSR31AE-1	<b>17M50</b>	X	X	X	X	X

<sup>1</sup> Nominal kW at 420V-3ph-50hz.

<sup>2</sup> Required when Economizer is factory installed with factory or field installed Power Exhaust Fan option.

<sup>3</sup> Required when Economizer is configured for horizontal airflow.

NOTE - Catalog and model numbers shown are for ordering field installed accessories.

OX - Configure To Order (Factory Installed) or Field Installed

O = Configure To Order (Factory Installed)

X = Field Installed

## OPTIONS / ACCESSORIES

Item	Model Number	Catalog Number	Unit				
			036	048	060	072	074
<b>INDOOR AIR QUALITY</b>							
<b>Air Filters</b>							
Healthy Climate® High Efficiency Air Filters	MERV 8 (406 x 508 x 51 mm) - C1FLTR15A-1-	<b>54W20</b>	OX	OX			
	MERV 13 (406 x 508 x 51 mm) - T1FLTR40A-1-	<b>52W37</b>	OX	OX			
Order 4 per unit	MERV 8 (508 x 508 x 51 mm) - C1FLTR15D-1-	<b>54W21</b>			OX	OX	OX
	MERV 13 (508 x 508 x 51 mm) - C1FLTR40D-1-	<b>52W39</b>			OX	OX	OX
Replaceable Media Filter With Metal Mesh Frame (includes non-pleated filter media)	406 x 508 x 51 mm (Order 4) - K1FLTR30A-1	<b>39W09</b>	X	X			
	508 x 508 x 51 mm (Order 4) - K1FLTR30A-2	<b>44N60</b>			X	X	X
<b>Indoor Air Quality (CO<sub>2</sub>) Sensors</b>							
Sensor - Wall-mount, off-white plastic cover with LCD display	C0SNSR50AE1L	<b>77N39</b>	X	X	X	X	X
Sensor - Wall-mount, off-white plastic cover, no display	C0SNSR52AE1L	<b>87N53</b>	X	X	X	X	X
Sensor - Black plastic case with LCD display, rated for plenum mounting	C0SNSR51AE1L	<b>87N52</b>	X	X	X	X	X
Sensor - Wall-mount, black plastic case, no display, rated for plenum mounting	C0SNSR53AE1L	<b>87N54</b>	X	X	X	X	X
CO <sub>2</sub> Sensor Duct Mounting Kit - for downflow applications	COMISC19AE1-	<b>85L43</b>	X	X	X	X	X
Aspiration Box - for duct mounting non-plenum rated CO <sub>2</sub> sensors ( <b>87N53</b> or <b>77N39</b> )	COMISC16AE1-	<b>90N43</b>	X	X	X	X	X
<b>UVC Germicidal Lamps</b>							
<sup>1</sup> Healthy Climate® UVC Light Kit (220V-1ph)	C1UVCL10AN1-	<b>21A92</b>	OX	OX	OX	OX	OX
<b>ROOF CURBS</b>							
<b>Hybrid Roof Curbs, Downflow</b>							
203 mm height	C1CURB70A-1	<b>11F50</b>	X	X	X	X	X
356 mm height	C1CURB71A-1	<b>11F51</b>	X	X	X	X	X
457 mm height	C1CURB72A-1	<b>11F52</b>	X	X	X	X	X
610 mm height	C1CURB73A-1	<b>11F53</b>	X	X	X	X	X
<b>Adjustable Pitch Curb, Downflow</b>							
356 mm height	C1CURB55AT1	<b>43W27</b>	X	X	X	X	X
<b>Transition Curb</b>							
Matches Emergence® 036-072 Units to existing L Series® Curbs	E1CURB60A-1	<b>20W06</b>	X	X	X	X	X
<b>CEILING DIFFUSERS</b>							
Step-Down - Order one	RTD9-65S	<b>13K60</b>	X	X	X		
	RTD11-95S	<b>13K61</b>				X	X
Flush - Order one	FD9-65S	<b>13K55</b>	X	X	X		
	FD11-95S	<b>13K56</b>				X	X
Transitions (Supply and Return) - Order one	T1TRAN10AN1	<b>17W53</b>	X	X	X		
	T1TRAN20N-1	<b>17W54</b>				X	X
<sup>1</sup> Lamps operate on 220V single-phase power supply. Step-down transformer must be field supplied for field installation for 380/420V primary to 220V secondary. Alternately, a separate 220V power supply may be used to directly power the UVC ballast(s).							
NOTE - Catalog and model numbers shown are for ordering field installed accessories. OX - Configure To Order (Factory Installed) or Field Installed O = Configure To Order (Factory Installed) X = Field Installed							

## SPECIFICATIONS

General Data		Nominal kW (Tons)	10.6 kW (3 Ton)	14 kW (4 Ton)	17.6 kW (5 Ton)	21 kW (6 Ton)	21 kW (6 Ton)
Model Number			LCH036S4T	LCH048S4T	LCH060S4T	LCH072H4B	LCH074H4T
Efficiency Type			Standard	Standard	Standard	High	High
Blower Type			Two Speed Belt Drive	Two Speed Belt Drive	Two Speed Belt Drive	Single Speed Belt Drive	Two Speed Belt Drive
<b>Cooling Performance</b>	Gross Cooling Capacity - kW (Btuh)		9.5 (32 400)	12.6 (43 000)	16.4 (56 000)	19.6 (67 000)	18.3 (62 300)
	Net Cooling Capacity - kW (Btuh)		<sup>1</sup> 9.2 (31 400)	<sup>1</sup> 12.2 (41 500)	<sup>1</sup> 15.9 (54 500)	<sup>2</sup> 19.2 (65 500)	17.5 (59 700)
	AHRI Rated Air Flow - L/s (cfm)		565 (1200)	755 (1600)	825 (1750)	905 (1920)	991 (2100)
	Total Unit Power - kW		2.7	3.7	4.5	5.2	4.9
	SEER (Btuh/Watt)		<sup>1</sup> 15.0	<sup>1</sup> 15.0	<sup>1</sup> 15.5	---	---
	IEER (Btuh/Watt)		---	---	---	<sup>2</sup> 13.5	<sup>2</sup> 16.2
	<sup>1</sup> EER (Btuh/Watt) at 35°C (95°F)		<sup>1</sup> 11.5	<sup>1</sup> 11.8	<sup>1</sup> 12.0	<sup>2</sup> 12.0	<sup>2</sup> 12.2
<sup>3</sup> EER (Btuh/Watt) at 46°C (115°F)		8.1	8.2	8.3	8.5	8.5	
<b>Refrigerant Charge</b>	Refrigerant Type		R-410A	R-410A	R-410A	R-410A	R-410A
	Charge		1.96 kg (4 lbs. 5 oz.)	2.83 kg (6 lbs. 4 oz.)	3.63 kg (8 lbs. 0 oz.)	3.40 kg (7 lbs. 8 oz.)	3.23 kg (7 lbs 2 oz.)
	Conventional Fin/Tube Coil		3.86 kg (8 lbs. 8 oz.)	5.05 kg (11 lbs. 2 oz.)	6.35 kg (14 lbs. 0 oz.)	6.24 kg (13 lbs. 12 oz.)	6.21 kg (13 lbs. 11 oz.)
	Environ™ Coil System With Humiditrol®		2.32 kg (5 lbs. 2 oz.)	2.95 kg (6 lbs. 8 oz.)	3.63 kg (8 lbs. 0 oz.)	4.08 kg (9 lbs. 0 oz.)	4.05 kg (8 lbs. 15 oz.)
	Conventional Fin/Tube With Humiditrol® Option		4.17 kg (9 lbs. 3 oz.)	5.56 kg (12 lbs. 4 oz.)	7.26 kg (16 lbs. 0 oz.)	6.89 kg (15 lbs. 3 oz.)	7.12 kg (15 lbs. 11 oz.)
	Electric Heat Available - See Page 38		5.7 and 11.5 kW		5.7, 11.5, and 17.2 kW	5.7, 11.5, 17.2 and 23 kW	5.7, 11.5, 17.2 and 23 kW
<b>Compressor Type (number)</b>			Scroll (1)	Scroll (1)	Scroll (1)	Scroll (1)	Scroll (1)
<b>Outdoor Coil Environ/(Fin/Tube)</b>	Net face area (total) - m <sup>2</sup> (sq. ft.)		1.09 (11.70)/1.45 (15.60)	1.09 (11.70)/1.45 (15.60)	1.65 (17.80)/1.79 (19.30)	1.65 (17.80)/1.79 (19.30)	1.65 (17.80)/1.79 (19.30)
	Number of rows		1 (1.5)	1 (2)	1 (2)	1 (2)	1 (2)
	Fins per m (Fins per inch)		788 (20)	788 (20)	788 (20)	788 (20)	788 (20)
<b>Outdoor Coil Fans</b>	Motor - (No.) W (horsepower)		(1) 125 (1/6)	(1) 185 (1/4)	(1) 250 1/3	(1) 250 (1/3)	(1) 249 (1/3)
	Motor rev/min		688	688	896	896	900
	Total Motor Input - watts		128	176	313	313	284
	Diameter - (No.) mm (in.)		(1) 610 (24)	(1) 610 (24)	(1) 610 (24)	(1) 610 (24)	(1) 610 (24)
	Number of blades		3	3	3	3	3
	Total air volume - L/s (cfm)		1180 (2500)	1295 (2750)	1885 (4000)	1885 (4000)	1848 (3900)
<b>Indoor Coils</b>	Net face area (total) - m <sup>2</sup> (sq. ft.)		0.72 (7.78)	0.72 (7.78)	0.90 (9.72)	0.90 (9.72)	0.90 (9.72)
	Tube diameter - mm (in.)		9.5 (3/8)	9.5 (3/8)	9.5 (3/8)	9.5 (3/8)	9.5 (3/8)
	Number of rows		3	4	4	4	4
	Fins per m (Fins per inch)		551 (14)	551 (14)	551 (14)	551 (14)	551 (14)
	Drain connection (Number) and size - in.		(1) 1 NPT	(1) 1 NPT	(1) 1 NPT	(1) 1 NPT	(1) 1 NPT
Expansion device type			Balance port thermal expansion valve, removable head				
<b>Indoor Blower and Drive Selection</b>	Nominal Motor kW (hp)		0.47 (0.63)	0.47 (0.63)	0.62 (0.83)	1.5 (2)	1.2 (1.66)
	Maximum usable motor kW (hp)		0.54 (0.72)	0.54 (0.72)	0.71 (0.95)	1.72 (2.3)	1.4 (1.9)
	Kit # (rev/min range)		A01 (low 374-561) (high 546-842)	A02 (low 414 621) (high 621-931)	A03 (low 463-694) (high 694-1042)	AA02 (527-729) AA03 (665-921) AA04 (768-1023)	AA02 (527-729) AA03 (665-921) AA04 (768-1023)
	Nominal Motor kW (hp)		0.62 (0.83)	1.24 (1.66)	1.24 (1.66)	---	---
	Maximum usable motor kW (hp)		0.71 (0.95)	1.42 (1.91)	1.42 (1.91)	---	---
	Motor - Drive Kit Number (rev/min range)		A05 (low 498-748) (high 748-1122)	A06 (low 595-794) (high 893-1191)	A07 (low 673-860) (high 1010-1290)	---	---
	Blower wheel nominal diameter x width - mm (in.)		(1) 254 x 254 (10 x 10)	(1) 254 x 254 (10 x 10)	(1) 254 x 254 (10 x 10)	(1) 381 x 229 (15 x 9)	1) 381 x 229 (15 x 9)
<b>Filters</b>	Type of filter		disposable				
	Number and size - mm (in.)		(4) 406 x 508 x 51 (16 x 20 x 2)		(4) 508 x 508 x 51 (20 x 20 x 2)		
<b>Electrical characteristics</b>			380/420V-50 hz-3 phase with neutral (No neutral on CE marked models)				

NOTE - Net capacity includes evaporator blower motor heat deduction. Gross capacity does not include evaporator blower motor heat deduction.

<sup>1,2</sup> Tested at conditions which are based on AHRI Standard <sup>1</sup> 210/240 or <sup>2</sup> 340/360; 35°C (95°F) outdoor air temperature and 27°C (80°F) dry bulb/19°C (67°F) wet bulb entering evaporator air; minimum external duct static pressure while operating at rated voltage and air volumes.

<sup>3</sup> Rated at 46°C (115°F) outdoor air temperature and 27°C (80°F) db/19°C (67°F) wb entering evaporator air (T3 Conditions).

<sup>4</sup> Using total air volume and system static pressure requirements determine from blower performance tables rpm and motor hp required. Maximum usable hp of motors furnished are shown. If motors of comparable hp are used, be sure to keep within the service factor limitations outlined on the motor nameplate.

# COOLING RATINGS

NOTE - For Temperatures and Capacities not shown in tables, see bulletin - Cooling Unit Rating Table Correction Factor Data in Miscellaneous Engineering Data section.

## 10.6 kW - LCH036S4 (1ST STAGE)

Entering Wet Bulb Temperature	Total Air Volume	Outdoor Air Temperature Entering Outdoor Coil																							
		18°C						24°C						29°C						35°C					
		Total Cool Cap.	Comp. Motor Input	Sensible To Total Ratio (S/T)			Total Cool Cap.	Comp. Motor Input	Sensible To Total Ratio (S/T)			Total Cool Cap.	Comp. Motor Input	Sensible To Total Ratio (S/T)			Total Cool Cap.	Comp. Motor Input	Sensible To Total Ratio (S/T)						
				Dry Bulb					Dry Bulb					Dry Bulb					Dry Bulb						
L/s	kW	kW	24°C	27°C	29°C	kW	kW	24°C	27°C	29°C	kW	kW	24°C	27°C	29°C	kBtuh	kW	24°C	27°C	29°C					
17°C	300	7.1	.93	0.71	0.85	1.00	6.7	1.09	0.72	0.88	1.00	6.2	1.26	0.73	0.91	1.00	5.8	1.47	0.75	0.94	1.00				
	380	7.5	.93	0.76	0.94	1.00	7.1	1.08	0.77	0.97	1.00	6.6	1.25	0.79	1.00	1.00	6.2	1.45	0.82	1.00	1.00				
	455	7.9	.92	0.81	1.00	1.00	7.4	1.07	0.84	1.00	1.00	7.0	1.24	0.87	1.00	1.00	6.6	1.44	0.90	1.00	1.00				
19°C	300	7.5	.93	0.56	0.68	0.81	7.1	1.08	0.57	0.70	0.83	6.7	1.25	0.57	0.71	0.86	6.2	1.45	0.57	0.73	0.89				
	380	7.9	.92	0.59	0.74	0.90	7.5	1.07	0.59	0.75	0.93	7.0	1.24	0.60	0.77	0.96	6.5	1.44	0.61	0.79	1.00				
	455	8.3	.92	0.62	0.79	0.98	7.8	1.07	0.62	0.81	1.00	7.3	1.24	0.65	0.84	1.00	6.8	1.44	0.66	0.87	1.00				
22°C	300	8.0	.92	0.42	0.54	0.66	7.6	1.07	0.42	0.55	0.68	7.1	1.24	0.42	0.56	0.69	6.6	1.44	0.42	0.56	0.70				
	380	8.4	.92	0.44	0.58	0.72	7.9	1.06	0.44	0.59	0.73	7.4	1.24	0.43	0.58	0.75	6.9	1.43	0.43	0.60	0.77				
	455	8.7	.92	0.45	0.61	0.77	8.2	1.06	0.44	0.62	0.79	7.7	1.23	0.45	0.63	0.81	7.2	1.42	0.46	0.65	0.85				

## 10.6 kW - LCH036S4 (2ND STAGE)

Entering Wet Bulb Temperature	Total Air Volume	Outdoor Air Temperature Entering Outdoor Coil																							
		26.7°C						35°C						43.3°C						46°C					
		Total Cool Cap.	Comp. Motor Input	Sensible To Total Ratio (S/T)			Total Cool Cap.	Comp. Motor Input	Sensible To Total Ratio (S/T)			Total Cool Cap.	Comp. Motor Input	Sensible To Total Ratio (S/T)			Total Cool Cap.	Comp. Motor Input	Sensible To Total Ratio (S/T)						
				Dry Bulb					Dry Bulb					Dry Bulb					Dry Bulb						
L/s	kW	kW	24°C	27°C	29°C	kW	kW	24°C	27°C	29°C	kW	kW	24°C	27°C	29°C	kW	kW	24°C	27°C	29°C					
17.2°C	455	9.2	1.80	0.74	0.91	1.00	8.4	2.13	0.76	0.95	1.00	7.5	2.54	0.79	1.00	1.00	7.3	2.70	0.82	1.00	1.00				
	565	9.6	1.81	0.80	1.00	1.00	8.9	2.15	0.83	1.00	1.00	8.1	2.56	0.88	1.00	1.00	7.8	2.71	0.92	1.00	1.00				
	680	10.1	1.83	0.86	1.00	1.00	9.3	2.16	0.92	1.00	1.00	8.4	2.57	0.97	1.00	1.00	8.2	2.72	0.99	1.00	1.00				
19.4°C	455	9.7	1.82	0.58	0.72	0.87	8.9	2.15	0.59	0.74	0.91	8.0	2.56	0.60	0.77	0.96	7.7	2.71	0.61	0.81	0.98				
	565	10.1	1.83	0.61	0.78	0.96	9.3	2.16	0.63	0.81	1.00	8.3	2.57	0.65	0.86	1.00	8.0	2.71	0.67	0.89	1.00				
	680	10.5	1.84	0.65	0.84	1.00	9.6	2.17	0.67	0.89	1.00	8.6	2.57	0.70	0.95	1.00	8.2	2.72	0.72	0.97	1.00				
21.7°C	455	10.3	1.84	0.43	0.57	0.70	9.4	2.16	0.42	0.58	0.72	8.5	2.57	0.43	0.59	0.75	8.1	2.72	0.43	0.61	0.78				
	565	10.7	1.85	0.45	0.61	0.76	9.8	2.17	0.44	0.62	0.79	8.8	2.57	0.45	0.64	0.83	8.5	2.72	0.46	0.67	0.87				
	680	11.0	1.86	0.46	0.64	0.83	10.1	2.18	0.47	0.66	0.87	9.1	2.58	0.47	0.69	0.93	8.7	2.73	0.48	0.72	0.96				

Entering Wet Bulb Temperature	Total Air Volume	Outdoor Air Temperature Entering Outdoor Coil														
		48°C					50°C					51.7°C				
		Total Cool Cap.	Comp. Motor Input	Sensible To Total Ratio (S/T)			Total Cool Cap.	Comp. Motor Input	Sensible To Total Ratio (S/T)			Total Cool Cap.	Comp. Motor Input	Sensible To Total Ratio (S/T)		
				Dry Bulb					Dry Bulb					Dry Bulb		
L/s	kW	kW	24°C	27°C	29°C	kW	kW	24°C	27°C	29°C	kW	kW	24°C	27°C	29°C	
17.2°C	455	7.1	2.82	0.84	1.00	1.00	6.9	2.95	0.85	1.00	1.00	6.7	3.07	0.84	1.00	1.00
	565	7.6	2.83	0.93	1.00	1.00	7.4	2.96	0.95	1.00	1.00	7.2	3.08	0.96	1.00	1.00
	680	8.0	2.84	1.00	1.00	1.00	7.7	2.97	1.00	1.00	1.00	7.5	3.09	1.00	1.00	1.00
19.4°C	455	7.4	2.82	0.62	0.81	1.00	7.2	2.95	0.63	0.83	1.00	7.0	3.07	0.62	0.82	1.00
	565	7.7	2.83	0.68	0.91	1.00	7.5	2.96	0.69	0.92	1.00	7.2	3.08	0.68	0.93	1.00
	680	8.0	2.84	0.73	0.99	1.00	7.7	2.96	0.74	1.00	1.00	7.5	3.09	0.73	1.00	1.00
21.7°C	455	7.9	2.84	0.43	0.61	0.79	7.6	2.97	0.43	0.62	0.80	7.4	3.08	0.42	0.62	0.79
	565	8.2	2.84	0.46	0.68	0.88	7.9	2.97	0.46	0.69	0.90	7.7	3.09	0.46	0.68	0.91
	680	8.4	2.85	0.48	0.73	0.97	8.1	2.97	0.48	0.74	0.99	7.9	3.09	0.48	0.73	1.00

# COOLING RATINGS

NOTE - For Temperatures and Capacities not shown in tables, see bulletin - Cooling Unit Rating Table Correction Factor Data in Miscellaneous Engineering Data section.

## 14 kW - LCH048S4 (1ST STAGE)

Entering Wet Bulb Temperature	Total Air Volume	Outdoor Air Temperature Entering Outdoor Coil																							
		18°C						24°C						29°C						35°C					
		Total Cool Cap.	Comp. Motor Input	Sensible To Total Ratio (S/T)			Total Cool Cap.	Comp. Motor Input	Sensible To Total Ratio (S/T)			Total Cool Cap.	Comp. Motor Input	Sensible To Total Ratio (S/T)			Total Cool Cap.	Comp. Motor Input	Sensible To Total Ratio (S/T)						
				Dry Bulb					Dry Bulb					Dry Bulb					Dry Bulb						
L/s	kW	kW	24°C	27°C	29°C	kW	kW	24°C	27°C	29°C	kW	kW	24°C	27°C	29°C	kBtu/h	kW	24°C	27°C	29°C					
17°C	400	9.7	1.13	0.69	0.84	1.00	9.1	1.36	0.70	0.86	1.00	8.6	1.60	0.71	0.89	1.00	7.9	1.87	0.72	0.91	1.00				
	505	10.2	1.12	0.75	0.94	1.00	9.7	1.34	0.76	0.97	1.00	9.1	1.59	0.77	1.00	1.00	8.5	1.86	0.79	1.00	1.00				
	605	10.8	1.11	0.81	1.00	1.00	10.3	1.33	0.83	1.00	1.00	9.7	1.57	0.86	1.00	1.00	9.1	1.85	0.89	1.00	1.00				
19°C	400	10.4	1.12	0.55	0.68	0.80	9.8	1.34	0.55	0.68	0.82	9.2	1.58	0.55	0.69	0.84	8.6	1.86	0.54	0.70	0.87				
	505	11.0	1.11	0.57	0.72	0.89	10.4	1.33	0.56	0.74	0.92	9.7	1.57	0.59	0.75	0.95	9.1	1.85	0.60	0.77	0.99				
	605	11.4	1.10	0.61	0.78	0.98	10.8	1.32	0.62	0.79	1.00	10.1	1.56	0.62	0.83	1.00	9.4	1.84	0.64	0.85	1.00				
22°C	400	11.1	1.10	0.42	0.53	0.64	10.6	1.32	0.41	0.54	0.65	9.9	1.57	0.40	0.54	0.66	9.2	1.84	0.40	0.54	0.68				
	505	11.7	1.09	0.42	0.56	0.70	11.0	1.31	0.39	0.55	0.71	10.4	1.56	0.43	0.57	0.73	9.7	1.83	0.40	0.58	0.75				
	605	12.2	1.08	0.43	0.60	0.76	11.5	1.30	0.42	0.61	0.77	10.8	1.55	0.44	0.62	0.79	10.1	1.82	0.43	0.63	0.82				

## 14 kW - LCH048S4 (2ND STAGE)

Entering Wet Bulb Temperature	Total Air Volume	Outdoor Air Temperature Entering Outdoor Coil																			
		26.7°C					35°C					43.3°C					46°C				
		Total Cool Cap.	Comp. Motor Input	Sensible To Total Ratio (S/T)			Total Cool Cap.	Comp. Motor Input	Sensible To Total Ratio (S/T)			Total Cool Cap.	Comp. Motor Input	Sensible To Total Ratio (S/T)			Total Cool Cap.	Comp. Motor Input	Sensible To Total Ratio (S/T)		
				Dry Bulb					Dry Bulb					Dry Bulb					Dry Bulb		
L/s	kW	kW	24°C	27°C	29°C	kW	kW	24°C	27°C	29°C	kW	kW	24°C	27°C	29°C	kW	kW	24°C	27°C	29°C	
17.2°C	605	12.4	2.27	0.73	0.90	1.00	11.3	2.69	0.75	0.95	1.00	10.1	3.20	0.78	1.00	1.00	9.8	3.39	0.83	1.00	1.00
	755	13.1	2.29	0.79	1.00	1.00	12.1	2.71	0.82	1.00	1.00	10.9	3.24	0.88	1.00	1.00	10.5	3.43	0.92	1.00	1.00
	905	13.9	2.31	0.87	1.00	1.00	12.7	2.74	0.92	1.00	1.00	11.6	3.26	0.98	1.00	1.00	11.2	3.46	1.00	1.00	1.00
19.4°C	605	13.3	2.29	0.57	0.71	0.86	12.1	2.71	0.56	0.72	0.90	10.9	3.23	0.59	0.76	0.96	10.4	3.42	0.60	0.80	0.99
	755	13.9	2.31	0.61	0.77	0.97	12.7	2.74	0.61	0.80	1.00	11.3	3.25	0.63	0.85	1.00	10.8	3.44	0.66	0.89	1.00
	905	14.3	2.33	0.64	0.84	1.00	13.1	2.75	0.66	0.89	1.00	11.7	3.27	0.69	0.96	1.00	11.2	3.45	0.72	0.98	1.00
21.7°C	605	14.2	2.32	0.42	0.56	0.68	12.9	2.74	0.41	0.56	0.70	11.6	3.26	0.41	0.57	0.73	11.2	3.46	0.42	0.60	0.78
	755	14.8	2.34	0.44	0.59	0.75	13.5	2.76	0.43	0.61	0.77	12.1	3.28	0.43	0.62	0.82	11.6	3.47	0.44	0.65	0.87
	905	15.2	2.35	0.45	0.64	0.81	13.9	2.77	0.45	0.65	0.86	12.5	3.30	0.47	0.68	0.93	12.0	3.49	0.48	0.72	0.96

Entering Wet Bulb Temperature	Total Air Volume	Outdoor Air Temperature Entering Outdoor Coil														
		48°C					50°C					51.7°C				
		Total Cool Cap.	Comp. Motor Input	Sensible To Total Ratio (S/T)			Total Cool Cap.	Comp. Motor Input	Sensible To Total Ratio (S/T)			Total Cool Cap.	Comp. Motor Input	Sensible To Total Ratio (S/T)		
				Dry Bulb					Dry Bulb					Dry Bulb		
L/s	kW	kW	24°C	27°C	29°C	kW	kW	24°C	27°C	29°C	kW	kW	24°C	27°C	29°C	
17.2°C	605	9.5	3.56	0.84	1.00	1.00	9.2	3.72	0.85	1.00	1.00	9.0	3.88	0.84	1.00	1.00
	755	10.2	3.58	0.94	1.00	1.00	10.0	3.75	0.95	1.00	1.00	9.6	3.91	0.96	1.00	1.00
	905	10.8	3.61	1.00	1.00	1.00	10.5	3.78	1.00	1.00	1.00	10.2	3.93	1.00	1.00	1.00
19.4°C	605	10.1	3.58	0.61	0.81	1.00	9.7	3.74	0.61	0.82	1.00	9.4	3.90	0.60	0.80	1.00
	755	10.5	3.60	0.67	0.91	1.00	10.1	3.76	0.68	0.93	1.00	9.8	3.92	0.66	0.93	1.00
	905	10.8	3.61	0.72	0.99	1.00	10.4	3.77	0.75	1.00	1.00	10.2	3.93	0.72	1.00	1.00
21.7°C	605	10.8	3.60	0.42	0.59	0.78	10.4	3.77	0.41	0.60	0.80	10.1	3.93	0.40	0.60	0.78
	755	11.3	3.63	0.45	0.66	0.89	10.8	3.79	0.45	0.67	0.90	10.5	3.95	0.44	0.66	0.90
	905	11.6	3.64	0.48	0.72	0.97	11.2	3.81	0.50	0.73	0.99	10.8	3.97	0.45	0.72	1.00

# COOLING RATINGS

NOTE - For Temperatures and Capacities not shown in tables, see bulletin - Cooling Unit Rating Table Correction Factor Data in Miscellaneous Engineering Data section.

## 17.6 kW - LCH060S4 (1ST STAGE)

Entering Wet Bulb Temperature	Total Air Volume	Outdoor Air Temperature Entering Outdoor Coil																							
		18°C						24°C						29°C						35°C					
		Total Cool Cap.	Comp. Motor Input	Sensible To Total Ratio (S/T)			Total Cool Cap.	Comp. Motor Input	Sensible To Total Ratio (S/T)			Total Cool Cap.	Comp. Motor Input	Sensible To Total Ratio (S/T)			Total Cool Cap.	Comp. Motor Input	Sensible To Total Ratio (S/T)						
				Dry Bulb					Dry Bulb					Dry Bulb					Dry Bulb						
L/s	kW	kW	24°C	27°C	29°C	kW	kW	24°C	27°C	29°C	kW	kW	24°C	27°C	29°C	kBtuh	kW	24°C	27°C	29°C					
17°C	505	12.0	1.33	0.72	0.86	1.00	11.3	1.60	0.72	0.88	1.00	10.6	1.89	0.73	0.90	1.00	9.8	2.21	0.73	0.92	1.00				
	630	12.7	1.31	0.77	0.93	1.00	12.0	1.58	0.77	0.96	1.00	11.3	1.88	0.78	0.99	1.00	10.6	2.19	0.82	1.00	1.00				
	755	13.3	1.29	0.82	1.00	1.00	12.7	1.56	0.84	1.00	1.00	12.0	1.86	0.87	1.00	1.00	11.3	2.18	0.90	1.00	1.00				
19°C	505	12.9	1.30	0.56	0.69	0.82	12.2	1.58	0.57	0.70	0.84	11.5	1.87	0.57	0.71	0.86	10.7	2.19	0.56	0.71	0.87				
	630	13.6	1.28	0.59	0.74	0.89	12.9	1.56	0.60	0.76	0.92	12.1	1.85	0.59	0.76	0.95	11.2	2.17	0.60	0.78	0.99				
	755	14.1	1.26	0.62	0.79	0.98	13.3	1.54	0.62	0.81	1.00	12.5	1.84	0.66	0.83	1.00	11.7	2.16	0.65	0.87	1.00				
22°C	505	13.8	1.27	0.43	0.55	0.67	13.1	1.55	0.43	0.55	0.67	12.3	1.85	0.42	0.55	0.69	11.4	2.17	0.40	0.55	0.69				
	630	14.5	1.25	0.46	0.58	0.71	13.8	1.53	0.43	0.59	0.73	12.9	1.83	0.43	0.58	0.74	12.0	2.15	0.42	0.59	0.75				
	755	15.0	1.23	0.47	0.61	0.77	14.2	1.51	0.48	0.61	0.79	13.4	1.82	0.46	0.63	0.82	12.4	2.14	0.45	0.64	0.83				

## 17.6 kW - LCH060S4 (2ND STAGE)

Entering Wet Bulb Temperature	Total Air Volume	Outdoor Air Temperature Entering Outdoor Coil																							
		26.7°C						35°C						43.3°C						46°C					
		Total Cool Cap.	Comp. Motor Input	Sensible To Total Ratio (S/T)			Total Cool Cap.	Comp. Motor Input	Sensible To Total Ratio (S/T)			Total Cool Cap.	Comp. Motor Input	Sensible To Total Ratio (S/T)			Total Cool Cap.	Comp. Motor Input	Sensible To Total Ratio (S/T)						
				Dry Bulb					Dry Bulb					Dry Bulb					Dry Bulb						
L/s	kW	kW	24°C	27°C	29°C	kW	kW	24°C	27°C	29°C	kW	kW	24°C	27°C	29°C	kW	kW	24°C	27°C	29°C					
17.2°C	755	15.6	2.67	0.75	0.91	1.00	14.2	3.17	0.76	0.95	1.00	12.7	3.78	0.79	0.99	1.00	12.3	4.00	0.82	1.00	1.00				
	945	16.4	2.69	0.80	1.00	1.00	15.2	3.20	0.83	1.00	1.00	13.8	3.82	0.88	1.00	1.00	13.3	4.04	0.91	1.00	1.00				
	1135	17.4	2.72	0.88	1.00	1.00	16.0	3.23	0.92	1.00	1.00	14.6	3.85	0.97	1.00	1.00	14.1	4.07	0.99	1.00	1.00				
19.4°C	755	16.7	2.70	0.58	0.72	0.87	15.2	3.20	0.58	0.74	0.91	13.7	3.81	0.58	0.76	0.95	13.2	4.04	0.59	0.79	0.97				
	945	17.5	2.73	0.61	0.78	0.96	16.0	3.23	0.63	0.81	1.00	14.3	3.84	0.64	0.86	1.00	13.8	4.07	0.66	0.88	1.00				
	1135	18.1	2.75	0.65	0.86	1.00	16.5	3.25	0.67	0.89	1.00	14.8	3.86	0.70	0.95	1.00	14.2	4.08	0.72	0.97	1.00				
21.7°C	755	17.8	2.74	0.43	0.57	0.70	16.4	3.24	0.42	0.57	0.72	14.7	3.85	0.41	0.58	0.74	14.2	4.07	0.42	0.59	0.76				
	945	18.6	2.76	0.44	0.60	0.76	17.1	3.27	0.45	0.62	0.79	15.4	3.88	0.44	0.64	0.83	14.8	4.10	0.45	0.65	0.86				
	1135	19.3	2.78	0.46	0.65	0.82	17.6	3.29	0.46	0.66	0.87	15.9	3.91	0.46	0.69	0.92	15.3	4.13	0.47	0.71	0.94				

Entering Wet Bulb Temperature	Total Air Volume	Outdoor Air Temperature Entering Outdoor Coil																	
		48°C						50°C						51.7°C					
		Total Cool Cap.	Comp. Motor Input	Sensible To Total Ratio (S/T)			Total Cool Cap.	Comp. Motor Input	Sensible To Total Ratio (S/T)			Total Cool Cap.	Comp. Motor Input	Sensible To Total Ratio (S/T)					
				Dry Bulb					Dry Bulb					Dry Bulb					
L/s	kW	kW	24°C	27°C	29°C	kW	kW	24°C	27°C	29°C	kW	kW	24°C	27°C	29°C				
17.2°C	755	11.9	4.18	0.83	1.00	1.00	11.6	4.38	0.84	1.00	1.00	11.3	4.56	0.84	1.00	1.00			
	945	12.9	4.22	0.92	1.00	1.00	12.5	4.42	0.94	1.00	1.00	12.2	4.59	0.95	1.00	1.00			
	1135	13.7	4.26	1.00	1.00	1.00	13.3	4.45	1.00	1.00	1.00	12.9	4.63	1.00	1.00	1.00			
19.4°C	755	12.8	4.22	0.61	0.80	0.98	12.3	4.41	0.61	0.81	1.00	11.9	4.58	0.61	0.81	1.00			
	945	13.4	4.24	0.67	0.90	1.00	12.9	4.43	0.68	0.91	1.00	12.5	4.61	0.67	0.92	1.00			
	1135	13.8	4.26	0.72	0.98	1.00	13.3	4.44	0.73	0.99	1.00	12.9	4.62	0.72	1.00	1.00			
21.7°C	755	13.7	4.25	0.42	0.60	0.77	13.3	4.45	0.41	0.60	0.78	12.9	4.62	0.42	0.60	0.78			
	945	14.4	4.29	0.45	0.66	0.87	13.9	4.48	0.45	0.67	0.88	13.5	4.66	0.44	0.67	0.89			
	1135	14.8	4.31	0.48	0.72	0.96	14.3	4.50	0.48	0.73	0.97	13.8	4.67	0.48	0.73	0.99			

# COOLING RATINGS

NOTE - For Temperatures and Capacities not shown in tables, see bulletin - Cooling Unit Rating Table Correction Factor Data in Miscellaneous Engineering Data section.

## 21 kW - LCH072H4 (FULL LOAD)

Entering Wet Bulb Temperature	Total Air Volume	Outdoor Air Temperature Entering Outdoor Coil																							
		26.7°C						35°C						43.3°C						46°C					
		Total Cool Cap.	Comp. Motor Input	Sensible To Total Ratio (S/T)			Total Cool Cap.	Comp. Motor Input	Sensible To Total Ratio (S/T)			Total Cool Cap.	Comp. Motor Input	Sensible To Total Ratio (S/T)			Total Cool Cap.	Comp. Motor Input	Sensible To Total Ratio (S/T)						
				Dry Bulb					Dry Bulb					Dry Bulb					Dry Bulb						
L/s	kW	kW	24°C	27°C	29°C	kW	kW	24°C	27°C	29°C	kW	kW	24°C	27°C	29°C	kW	kW	24°C	27°C	29°C					
17.2°C	905	19.1	3.55	0.72	0.90	1.00	17.5	4.15	0.74	0.95	1.00	15.6	4.86	0.77	1.00	1.00	15.1	5.11	0.83	1.00	1.00				
	1135	20.1	3.56	0.78	1.00	1.00	18.6	4.16	0.81	1.00	1.00	16.9	4.88	0.88	1.00	1.00	16.3	5.13	0.92	1.00	1.00				
	1360	21.2	3.58	0.86	1.00	1.00	19.6	4.17	0.91	1.00	1.00	17.9	4.89	0.98	1.00	1.00	17.2	5.15	1.00	1.00	1.00				
19.4°C	905	20.4	3.57	0.56	0.70	0.86	18.7	4.16	0.57	0.72	0.90	16.8	4.87	0.57	0.74	0.95	16.1	5.13	0.61	0.80	0.98				
	1135	21.3	3.58	0.59	0.76	0.97	19.5	4.17	0.60	0.79	1.00	17.5	4.89	0.62	0.84	1.00	16.9	5.14	0.67	0.89	1.00				
	1360	22.0	3.58	0.63	0.83	1.00	20.2	4.18	0.65	0.88	1.00	18.1	4.89	0.68	0.95	1.00	17.4	5.15	0.72	0.98	1.00				
21.7°C	905	21.7	3.58	0.41	0.55	0.68	20.0	4.17	0.41	0.56	0.70	17.9	4.89	0.41	0.57	0.72	17.2	5.15	0.41	0.59	0.77				
	1135	22.7	3.59	0.43	0.58	0.74	20.8	4.19	0.43	0.60	0.77	18.7	4.90	0.43	0.62	0.80	18.0	5.16	0.44	0.65	0.86				
	1360	23.4	3.60	0.44	0.63	0.80	21.4	4.19	0.45	0.64	0.85	19.3	4.91	0.46	0.67	0.92	18.6	5.17	0.47	0.71	0.95				

Entering Wet Bulb Temperature	Total Air Volume	Outdoor Air Temperature Entering Outdoor Coil																	
		48°C						50°C						51.7°C					
		Total Cool Cap.	Comp. Motor Input	Sensible To Total Ratio (S/T)			Total Cool Cap.	Comp. Motor Input	Sensible To Total Ratio (S/T)			Total Cool Cap.	Comp. Motor Input	Sensible To Total Ratio (S/T)					
				Dry Bulb					Dry Bulb					Dry Bulb					
L/s	kW	kW	24°C	27°C	29°C	kW	kW	24°C	27°C	29°C	kW	kW	24°C	27°C	29°C				
17.2°C	905	14.7	5.32	0.83	1.00	1.00	14.3	5.55	0.85	1.00	1.00	13.9	5.75	0.84	1.00	1.00			
	1135	15.8	5.34	0.93	1.00	1.00	15.4	5.56	0.95	1.00	1.00	14.9	5.77	0.96	1.00	1.00			
	1360	16.8	5.36	1.00	1.00	1.00	16.2	5.58	1.00	1.00	1.00	15.7	5.79	1.00	1.00	1.00			
19.4°C	905	15.6	5.34	0.61	0.81	1.00	15.0	5.55	0.62	0.82	1.00	14.5	5.75	0.60	0.79	1.00			
	1135	16.4	5.35	0.67	0.91	1.00	15.8	5.57	0.68	0.93	1.00	15.2	5.78	0.66	0.93	1.00			
	1360	16.8	5.36	0.73	0.99	1.00	16.2	5.58	0.74	1.00	1.00	15.7	5.78	0.71	1.00	1.00			
21.7°C	905	16.7	5.35	0.42	0.60	0.78	16.2	5.58	0.42	0.61	0.80	15.6	5.78	0.41	0.59	0.77			
	1135	17.4	5.37	0.45	0.67	0.88	16.9	5.59	0.45	0.68	0.90	16.3	5.80	0.44	0.65	0.89			
	1360	18.0	5.38	0.48	0.72	0.97	17.3	5.60	0.48	0.74	0.99	16.7	5.81	0.47	0.71	0.99			



# COOLING RATINGS

NOTE - For Temperatures and Capacities not shown in tables, see bulletin - Cooling Unit Rating Table Correction Factor Data in Miscellaneous Engineering Data section.

## 21 kW - LCH074H4 (1ST STAGE)

Entering Wet Bulb Temperature	Total Air Volume	Outdoor Air Temperature Entering Outdoor Coil																							
		18°C						24°C						29°C						35°C					
		Total Cool Cap.	Comp. Motor Input	Sensible To Total Ratio (S/T)			Total Cool Cap.	Comp. Motor Input	Sensible To Total Ratio (S/T)			Total Cool Cap.	Comp. Motor Input	Sensible To Total Ratio (S/T)			Total Cool Cap.	Comp. Motor Input	Sensible To Total Ratio (S/T)						
				Dry Bulb					Dry Bulb					Dry Bulb					Dry Bulb						
L/s	kW	kW	24°C	27°C	29°C	kW	kW	24°C	27°C	29°C	kW	kW	24°C	27°C	29°C	kBtuh	kW	24°C	27°C	29°C					
17°C	565	13.7	1.85	0.74	0.88	0.97	13.1	2.13	0.75	0.90	0.99	12.5	2.40	0.76	0.92	1.00	11.7	2.77	0.78	0.95	1.00				
	755	14.8	1.84	0.81	0.98	1.00	14.1	2.12	0.82	1.00	1.00	13.5	2.39	0.84	1.00	1.00	12.8	2.76	0.86	1.00	1.00				
	945	16.0	1.82	0.88	1.00	1.00	15.3	2.11	0.90	1.00	1.00	14.6	2.38	0.92	1.00	1.00	13.7	2.75	0.95	1.00	1.00				
19°C	565	14.7	1.84	0.59	0.74	0.82	14.0	2.13	0.60	0.75	0.84	13.3	2.40	0.61	0.76	0.86	12.5	2.77	0.62	0.78	0.88				
	755	15.8	1.83	0.65	0.82	0.92	15.0	2.11	0.66	0.82	0.94	14.3	2.39	0.64	0.84	0.96	13.3	2.76	0.67	0.87	0.99				
	945	16.5	1.82	0.69	0.89	1.00	15.7	2.10	0.71	0.91	1.00	15.0	2.38	0.71	0.93	1.00	14.0	2.75	0.73	0.96	1.00				
22°C	565	16.1	1.82	0.41	0.53	0.62	15.3	2.11	0.42	0.54	0.63	14.6	2.38	0.41	0.55	0.64	13.7	2.75	0.41	0.56	0.65				
	755	17.2	1.81	0.43	0.59	0.69	16.4	2.09	0.43	0.60	0.70	15.6	2.37	0.42	0.60	0.71	14.7	2.74	0.43	0.61	0.73				
	945	18.1	1.79	0.45	0.63	0.74	17.2	2.08	0.45	0.64	0.75	16.4	2.36	0.45	0.64	0.78	15.4	2.73	0.46	0.67	0.80				

## 21 kW - LCH074H4 (2ND STAGE)

Entering Wet Bulb Temperature	Total Air Volume	Outdoor Air Temperature Entering Outdoor Coil																							
		26.7°C						35°C						43.3°C						46°C					
		Total Cool Cap.	Comp. Motor Input	Sensible To Total Ratio (S/T)			Total Cool Cap.	Comp. Motor Input	Sensible To Total Ratio (S/T)			Total Cool Cap.	Comp. Motor Input	Sensible To Total Ratio (S/T)			Total Cool Cap.	Comp. Motor Input	Sensible To Total Ratio (S/T)						
				Dry Bulb					Dry Bulb					Dry Bulb					Dry Bulb						
L/s	kW	kW	24°C	27°C	29°C	kW	kW	24°C	27°C	29°C	kW	kW	24°C	27°C	29°C	kW	kW	24°C	27°C	29°C					
17.2°C	905	18.0	3.22	0.80	0.97	1.00	16.5	3.85	0.82	1.00	1.00	15.1	4.63	0.86	1.00	1.00	14.7	4.91	0.87	1.00	1.00				
	1135	19.1	3.25	0.87	1.00	1.00	17.8	3.90	0.90	1.00	1.00	16.2	4.66	0.95	1.00	1.00	15.7	4.94	0.97	1.00	1.00				
	1360	20.2	3.28	0.94	1.00	1.00	18.6	3.92	0.98	1.00	1.00	17.1	4.70	1.00	1.00	1.00	16.6	4.98	1.00	1.00	1.00				
19.4°C	905	19.0	3.25	0.64	0.81	0.91	17.5	3.88	0.65	0.83	0.95	15.8	4.65	0.67	0.86	0.99	15.2	4.93	0.68	0.88	1.00				
	1135	19.9	3.27	0.69	0.88	0.99	18.2	3.91	0.70	0.91	1.00	16.5	4.68	0.73	0.97	1.00	15.9	4.95	0.75	0.98	1.00				
	1360	20.5	3.29	0.73	0.95	1.00	18.8	3.93	0.76	0.99	1.00	17.1	4.69	0.79	1.00	1.00	16.5	4.97	0.81	1.00	1.00				
21.7°C	905	20.6	3.30	0.43	0.59	0.68	18.9	3.93	0.43	0.60	0.70	17.1	4.70	0.42	0.61	0.72	16.6	4.98	0.43	0.62	0.74				
	1135	21.5	3.32	0.44	0.62	0.74	19.7	3.96	0.45	0.64	0.77	17.8	4.72	0.45	0.66	0.80	17.2	5.00	0.44	0.68	0.82				
	1360	22.1	3.35	0.46	0.66	0.80	20.3	3.99	0.47	0.69	0.84	18.3	4.75	0.47	0.72	0.88	17.7	5.02	0.47	0.73	0.90				

Entering Wet Bulb Temperature	Total Air Volume	Outdoor Air Temperature Entering Outdoor Coil																	
		48°C						50°C						51.7°C					
		Total Cool Cap.	Comp. Motor Input	Sensible To Total Ratio (S/T)			Total Cool Cap.	Comp. Motor Input	Sensible To Total Ratio (S/T)			Total Cool Cap.	Comp. Motor Input	Sensible To Total Ratio (S/T)					
				Dry Bulb					Dry Bulb					Dry Bulb					
L/s	kW	kW	24°C	27°C	29°C	kW	kW	24°C	27°C	29°C	kW	kW	24°C	27°C	29°C				
17.2°C	905	14.3	5.14	0.88	1.00	1.00	14.0	5.37	0.89	1.00	1.00	13.6	5.57	0.91	1.00	1.00			
	1135	15.3	5.16	0.98	1.00	1.00	14.9	5.40	0.99	1.00	1.00	14.5	5.60	1.00	1.00	1.00			
	1360	16.1	5.20	1.00	1.00	1.00	15.7	5.43	1.00	1.00	1.00	15.2	5.62	1.00	1.00	1.00			
19.4°C	905	14.8	5.15	0.68	0.90	1.00	14.3	5.37	0.69	0.91	1.00	13.9	5.57	0.69	0.92	1.00			
	1135	15.4	5.17	0.75	0.99	1.00	14.9	5.40	0.76	1.00	1.00	14.6	5.60	0.77	1.00	1.00			
	1360	16.0	5.19	0.82	1.00	1.00	15.6	5.42	0.82	1.00	1.00	15.3	5.63	0.83	1.00	1.00			
21.7°C	905	16.1	5.19	0.43	0.63	0.75	15.6	5.42	0.43	0.63	0.76	15.2	5.62	0.42	0.63	0.76			
	1135	16.7	5.22	0.45	0.68	0.83	16.2	5.45	0.45	0.69	0.84	15.8	5.65	0.46	0.70	0.86			
	1360	17.2	5.24	0.48	0.74	0.91	16.7	5.47	0.48	0.75	0.93	16.1	5.66	0.48	0.76	0.94			



# HUMIDITROL® DEHUMIDIFICATION SYSTEM RATINGS

## 21 kW - LCH074H4 with HUMIDITROL OPERATING

Entering Wet Bulb Temperature	Total Air Volume	Outdoor Air Temperature Entering Outdoor Coil																							
		18°C						24°C						29°C						35°C					
		Total Cool Cap.	Comp. Motor Input	Sensible To Total Ratio (S/T)			Total Cool Cap.	Comp. Motor Input	Sensible To Total Ratio (S/T)			Total Cool Cap.	Comp. Motor Input	Sensible To Total Ratio (S/T)			Total Cool Cap.	Comp. Motor Input	Sensible To Total Ratio (S/T)						
				Dry Bulb					Dry Bulb					Dry Bulb					Dry Bulb						
L/s	kW	kW	24°C	27°C	29°C	kW	kW	24°C	27°C	29°C	kW	kW	24°C	27°C	29°C	kBtuh	kW	24°C	27°C	29°C					
17°C	565	10.0	2.62	0.46	0.63	0.80	8.0	2.88	0.39	0.58	0.76	6.2	3.20	0.21	0.49	0.76	4.2	3.57	-0.10	0.32	0.73				
	755	10.7	2.66	0.53	0.74	0.95	8.8	2.91	0.44	0.65	0.97	6.5	3.21	0.30	0.60	0.99	4.1	3.57	-0.02	0.55	1.00				
	945	11.2	2.69	0.60	0.84	1.00	8.8	2.92	0.52	0.84	1.00	6.4	3.21	0.39	0.83	1.00	3.8	3.55	0.11	0.85	1.00				
19°C	565	11.4	2.68	0.31	0.46	0.61	9.5	2.94	0.20	0.39	0.57	7.5	3.26	0.04	0.27	0.49	5.5	3.63	-0.25	0.07	0.37				
	755	12.3	2.72	0.35	0.52	0.71	10.1	2.97	0.23	0.46	0.68	7.8	3.27	0.06	0.35	0.63	5.5	3.63	-0.27	0.15	0.55				
	945	12.8	2.75	0.38	0.59	0.81	10.4	2.99	0.26	0.53	0.80	7.9	3.28	0.09	0.44	0.78	5.4	3.62	-0.26	0.26	0.76				
22°C	565	12.9	2.73	0.19	0.33	0.45	10.9	3.00	0.08	0.24	0.40	9.0	3.32	-0.08	0.11	0.30	6.9	3.70	-0.35	-0.10	0.16				
	755	13.8	2.78	0.20	0.37	0.52	11.6	3.03	0.08	0.28	0.47	9.3	3.34	-0.10	0.15	0.33	7.0	3.70	-0.41	-0.08	0.24				
	945	14.4	2.81	0.20	0.40	0.59	12.0	3.06	0.08	0.31	0.54	9.5	3.35	-0.12	0.18	0.47	6.9	3.70	-0.48	-0.06	0.34				

**BLOWER DATA**

**BELT DRIVE | 3 TON**

**BLOWER TABLE INCLUDES RESISTANCE FOR BASE UNIT ONLY WITH DRY INDOOR COIL AND AIR FILTERS IN PLACE.**

FOR ALL UNITS ADD:

- 1 - Any factory installed options air resistance (heat section, economizer, etc.).
- 2 - Any field installed accessories air resistance (duct resistance, diffuser, etc.).

See pPage 36 for blower motors and drives and wet coil and options/accessory air resistance data.

**DOWNFLOW**

Air Volume		External Static - Pa (in.w.g.)																													
		25 (0.10)		50 (0.20)		75 (0.30)		100 (0.40)		125 (0.50)		150 (0.60)		175 (0.70)		200 (0.80)		225 (0.90)		250 (1.00)											
L/s	cfm	Rev/min	kW	BHP	Rev/min	kW	BHP	Rev/min	kW	BHP	Rev/min	kW	BHP	Rev/min	kW	BHP	Rev/min	kW	BHP	Rev/min	kW	BHP									
330	700	447	0.07	0.09	517	0.09	0.12	589	0.11	0.15	663	0.13	0.17	739	0.14	0.19	815	0.15	0.20	883	0.17	0.23	938	0.19	0.25	988	0.20	0.27	1039	0.22	0.29
378	800	465	0.07	0.10	534	0.10	0.14	605	0.13	0.17	678	0.14	0.19	753	0.16	0.21	825	0.17	0.23	890	0.19	0.25	946	0.20	0.27	996	0.22	0.30	1047	0.24	0.32
425	900	486	0.09	0.12	554	0.12	0.16	623	0.15	0.20	695	0.16	0.22	767	0.17	0.23	836	0.19	0.25	897	0.21	0.28	953	0.22	0.30	1004	0.25	0.33	1055	0.26	0.35
472	1000	508	0.11	0.15	576	0.14	0.19	643	0.16	0.22	713	0.18	0.24	783	0.19	0.26	848	0.21	0.28	907	0.22	0.30	961	0.25	0.33	1011	0.27	0.36	1062	0.28	0.38
519	1100	533	0.13	0.18	599	0.16	0.22	665	0.19	0.25	733	0.20	0.27	800	0.21	0.28	863	0.23	0.31	919	0.25	0.34	971	0.27	0.36	1020	0.29	0.39	1070	0.31	0.41
566	1200	560	0.16	0.21	625	0.19	0.25	689	0.21	0.28	755	0.22	0.30	820	0.24	0.32	879	0.25	0.34	932	0.28	0.37	983	0.30	0.40	1031	0.32	0.43	1079	0.34	0.45
613	1300	591	0.18	0.24	654	0.21	0.28	716	0.23	0.31	779	0.25	0.33	841	0.26	0.35	897	0.28	0.38	948	0.31	0.41	996	0.33	0.44	1044	0.35	0.47	1091	0.37	0.49
661	1400	631	0.19	0.26	690	0.22	0.30	748	0.25	0.34	807	0.27	0.36	864	0.29	0.39	916	0.31	0.42	964	0.34	0.46	1011	0.37	0.49	1058	0.38	0.51	1105	0.40	0.54

Air Volume		External Static - Pa (in.w.g.)																													
		275 (1.10)		300 (1.20)		325 (1.30)		350 (1.40)		375 (1.50)		400 (1.60)		425 (1.70)		450 (1.80)		475 (1.90)		500 (2.00)											
L/s	cfm	Rev/min	kW	BHP	Rev/min	kW	BHP	Rev/min	kW	BHP	Rev/min	kW	BHP	Rev/min	kW	BHP	Rev/min	kW	BHP	Rev/min	kW	BHP									
330	700	1088	0.23	0.31	---	---	---	---	---	---	---	---	---	---	---	---	---	---	---	---	---	---									
378	800	1098	0.25	0.34	1144	0.27	0.36	1185	0.29	0.39	1224	0.31	0.42	---	---	---	---	---	---	---	---	---									
425	900	1106	0.28	0.37	1152	0.30	0.40	1193	0.32	0.43	1232	0.34	0.46	1269	0.37	0.49	1305	0.39	0.52	1340	0.41	0.55	1376	0.44	0.59	---	---	---	---	---	
472	1000	1111	0.31	0.41	1157	0.32	0.43	1199	0.35	0.47	1238	0.37	0.50	1276	0.40	0.53	1311	0.42	0.56	1347	0.45	0.60	1382	0.47	0.63	1417	0.50	0.67	1452	0.70	
519	1100	1118	0.33	0.44	1163	0.35	0.47	1206	0.38	0.51	1245	0.40	0.54	1282	0.43	0.58	1318	0.46	0.61	1353	0.48	0.65	1388	0.51	0.68	1423	0.54	0.72	1458	0.75	
566	1200	1127	0.36	0.48	1171	0.39	0.52	1213	0.41	0.55	1252	0.44	0.59	1289	0.46	0.62	1324	0.49	0.66	1358	0.52	0.70	1393	0.54	0.73	1428	0.57	0.77	1463	0.81	
613	1300	1137	0.40	0.53	1181	0.42	0.56	1221	0.45	0.60	1259	0.48	0.64	1296	0.51	0.68	1330	0.53	0.71	1364	0.56	0.75	1398	0.58	0.78	1432	0.61	0.82	1467	0.86	
661	1400	1150	0.43	0.57	1191	0.46	0.61	1231	0.48	0.65	1268	0.51	0.69	1303	0.54	0.73	1337	0.57	0.77	1371	0.60	0.80	1404	0.63	0.84	1437	0.66	0.88	1473	0.68	0.91

**BLOWER DATA**

**BELT DRIVE | 3 TON**

**BLOWER TABLE INCLUDES RESISTANCE FOR BASE UNIT ONLY WITH DRY INDOOR COIL AND AIR FILTERS IN PLACE.**

FOR ALL UNITS ADD:

1 - Any factory installed options air resistance (heat section, economizer, etc.).

2 - Any field installed accessories air resistance (duct resistance, diffuser, etc.).

See pPage 36 for blower motors and drives and wet coil and options/accessory air resistance data.

**HORIZONTAL**

Air Volume		External Static - Pa (in.w.g.)																										
		25 (0.10)		50 (0.20)		75 (0.30)		100 (0.40)		125 (0.50)		150 (0.60)		175 (0.70)		200 (0.80)		225 (0.90)		250 (1.00)								
L/s	cfm	Rev/ min	BHP	Rev/ min	BHP	Rev/ min	BHP	Rev/ min	BHP	Rev/ min	BHP	Rev/ min	BHP	Rev/ min	BHP	Rev/ min	BHP	Rev/ min	BHP	Rev/ min	BHP							
330	700	445	0.06	0.08	0.11	591	0.10	0.13	0.15	753	0.12	0.16	0.19	820	0.14	0.19	870	0.16	0.22	918	0.18	0.24	969	0.20	0.27	1021	0.22	0.29
378	800	463	0.07	0.09	0.12	608	0.10	0.14	0.16	766	0.13	0.18	0.21	830	0.16	0.21	878	0.18	0.24	926	0.20	0.27	977	0.22	0.29	1030	0.24	0.32
425	900	485	0.08	0.11	0.14	627	0.12	0.16	0.18	780	0.16	0.21	0.23	841	0.17	0.23	888	0.20	0.27	935	0.22	0.30	986	0.24	0.32	1039	0.26	0.35
472	1000	509	0.10	0.13	0.16	649	0.14	0.19	0.21	796	0.17	0.23	0.26	854	0.19	0.26	900	0.22	0.29	947	0.25	0.33	997	0.26	0.35	1048	0.28	0.38
519	1100	537	0.12	0.16	0.19	674	0.16	0.21	0.24	813	0.19	0.26	0.29	868	0.22	0.29	913	0.25	0.33	959	0.27	0.36	1008	0.29	0.39	1059	0.31	0.41
566	1200	567	0.14	0.19	0.22	700	0.18	0.24	0.27	833	0.22	0.30	0.33	884	0.25	0.33	928	0.28	0.37	974	0.30	0.40	1022	0.32	0.43	1071	0.34	0.45
613	1300	599	0.16	0.22	0.25	729	0.21	0.28	0.30	853	0.25	0.33	0.37	902	0.28	0.37	945	0.31	0.41	990	0.33	0.44	1037	0.35	0.47	1085	0.37	0.50
661	1400	634	0.19	0.26	0.29	758	0.23	0.31	0.34	875	0.28	0.38	0.42	921	0.31	0.42	964	0.34	0.46	1008	0.37	0.49	1054	0.39	0.52	1100	0.40	0.54

**External Static - Pa (in.w.g.)**

Air Volume		External Static - Pa (in.w.g.)																										
		275 (1.10)		300 (1.20)		325 (1.30)		350 (1.40)		375 (1.50)		400 (1.60)		425 (1.70)		450 (1.80)		475 (1.90)		500 (2.00)								
L/s	cfm	Rev/ min	BHP	Rev/ min	BHP	Rev/ min	BHP	Rev/ min	BHP	Rev/ min	BHP	Rev/ min	BHP	Rev/ min	BHP	Rev/ min	BHP	Rev/ min	BHP	Rev/ min	BHP							
330	700	1071	0.24	0.32	1169	0.30	0.40	1205	0.31	0.42	1248	0.37	0.49	1280	0.38	0.51	1310	0.40	0.54	1340	0.43	0.57	1377	0.48	0.64	1406	0.50	0.67
378	800	1082	0.25	0.34	1128	0.28	0.37	1169	0.30	0.40	1205	0.31	0.42	1248	0.37	0.49	1280	0.38	0.51	1310	0.40	0.54	1340	0.43	0.57	1377	0.48	0.64
425	900	1090	0.28	0.37	1137	0.30	0.40	1177	0.32	0.43	1214	0.34	0.46	1255	0.40	0.53	1287	0.42	0.56	1318	0.44	0.59	1347	0.46	0.61	1377	0.48	0.64
472	1000	1098	0.31	0.41	1143	0.33	0.44	1184	0.35	0.47	1221	0.37	0.50	1263	0.43	0.57	1295	0.45	0.60	1325	0.47	0.63	1355	0.49	0.66	1384	0.51	0.69
519	1100	1107	0.33	0.44	1150	0.35	0.47	1191	0.38	0.51	1228	0.40	0.54	1271	0.46	0.62	1303	0.49	0.66	1334	0.51	0.69	1363	0.54	0.72	1392	0.56	0.75
566	1200	1117	0.36	0.48	1160	0.39	0.52	1200	0.41	0.55	1237	0.44	0.59	1271	0.46	0.62	1303	0.49	0.66	1334	0.51	0.69	1363	0.54	0.72	1392	0.56	0.75
613	1300	1130	0.40	0.53	1171	0.43	0.57	1210	0.45	0.60	1246	0.48	0.64	1280	0.51	0.68	1312	0.53	0.71	1342	0.55	0.74	1372	0.58	0.78	1400	0.60	0.81
661	1400	1144	0.43	0.58	1183	0.46	0.62	1221	0.49	0.66	1256	0.52	0.70	1290	0.54	0.73	1321	0.57	0.77	1352	0.60	0.80	1381	0.63	0.84	1410	0.65	0.87

**BLOWER DATA**

**BELT DRIVE | 4 TON**

**BLOWER TABLE INCLUDES RESISTANCE FOR BASE UNIT ONLY WITH DRY INDOOR COIL AND AIR FILTERS IN PLACE.**

FOR ALL UNITS ADD:

- 1 - Any factory installed options air resistance (heat section, economizer, etc.).
- 2 - Any field installed accessories air resistance (duct resistance, diffuser, etc.).

See pPage 36 for blower motors and drives and wet coil and options/accessory air resistance data.

**DOWNFLOW**

Air Volume		External Static - Pa (in.w.g.)																				
		25 (0.10)		50 (0.20)		75 (0.30)		100 (0.40)		125 (0.50)		150 (0.60)		175 (0.70)		200 (0.80)		225 (0.90)		250 (1.00)		
L/s	cfm	Rev/ min	kW	BHP	Rev/ min	kW	BHP	Rev/ min	kW	BHP	Rev/ min	kW	BHP	Rev/ min	kW	BHP	Rev/ min	kW	BHP	Rev/ min	kW	BHP
425	900	496	0.10	0.13	568	0.12	0.16	0.18	0.15	0.20	779	0.16	0.22	844	0.19	0.25	905	0.21	0.28	960	0.22	0.30
472	1000	521	0.11	0.15	592	0.13	0.18	0.20	0.17	0.23	796	0.19	0.25	858	0.21	0.28	916	0.23	0.31	969	0.25	0.34
519	1100	548	0.13	0.18	618	0.16	0.21	0.23	0.19	0.25	814	0.21	0.28	873	0.23	0.31	929	0.25	0.34	980	0.28	0.37
566	1200	577	0.16	0.21	646	0.18	0.24	0.26	0.22	0.29	834	0.23	0.31	890	0.26	0.35	943	0.28	0.38	993	0.31	0.41
613	1300	611	0.18	0.24	677	0.20	0.27	0.30	0.24	0.32	856	0.26	0.35	909	0.29	0.39	959	0.31	0.42	1007	0.34	0.45
661	1400	654	0.19	0.26	713	0.22	0.29	0.33	0.27	0.36	878	0.29	0.39	928	0.32	0.43	976	0.35	0.47	1023	0.37	0.49
708	1500	698	0.21	0.28	751	0.24	0.32	0.36	0.30	0.40	901	0.33	0.44	948	0.36	0.48	995	0.38	0.51	1041	0.40	0.54
755	1600	738	0.24	0.32	785	0.27	0.36	0.41	0.34	0.45	923	0.37	0.49	969	0.40	0.53	1014	0.43	0.57	1061	0.44	0.59
802	1700	773	0.27	0.36	816	0.31	0.41	0.46	0.38	0.51	947	0.41	0.55	991	0.43	0.58	1036	0.46	0.62	1082	0.48	0.65
849	1800	803	0.31	0.42	844	0.35	0.47	0.52	0.43	0.57	972	0.46	0.61	1016	0.48	0.64	1060	0.51	0.68	1106	0.53	0.71
897	1900	831	0.36	0.48	872	0.40	0.54	0.59	0.47	0.63	1000	0.50	0.67	1043	0.53	0.71	1087	0.55	0.74	1131	0.58	0.78
Air Volume		External Static - Pa (in.w.g.)																				
		275 (1.10)		300 (1.20)		325 (1.30)		350 (1.40)		375 (1.50)		400 (1.60)		425 (1.70)		450 (1.80)		475 (1.90)		500 (2.00)		
L/s	cfm	Rev/ min	kW	BHP	Rev/ min	kW	BHP	Rev/ min	kW	BHP	Rev/ min	kW	BHP	Rev/ min	kW	BHP	Rev/ min	kW	BHP	Rev/ min	kW	BHP
425	900	1112	0.28	0.38	1157	0.30	0.40	1198	0.32	0.43	1273	0.37	0.49	1309	0.39	0.52	1344	0.42	0.56	1380	0.44	0.59
472	1000	1119	0.31	0.41	1164	0.33	0.44	1206	0.35	0.47	1281	0.40	0.54	1317	0.43	0.57	1352	0.45	0.60	1387	0.48	0.64
519	1100	1126	0.34	0.45	1171	0.36	0.48	1213	0.38	0.51	1288	0.43	0.58	1324	0.46	0.62	1359	0.48	0.65	1394	0.51	0.69
566	1200	1136	0.37	0.49	1180	0.39	0.52	1221	0.42	0.56	1296	0.47	0.63	1331	0.50	0.67	1365	0.52	0.70	1400	0.55	0.74
613	1300	1148	0.40	0.53	1190	0.43	0.57	1230	0.46	0.61	1304	0.51	0.68	1338	0.54	0.72	1372	0.57	0.76	1406	0.59	0.79
661	1400	1161	0.43	0.58	1202	0.46	0.62	1240	0.49	0.66	1312	0.55	0.74	1346	0.58	0.78	1379	0.60	0.81	1412	0.63	0.85
708	1500	1175	0.48	0.64	1214	0.51	0.68	1252	0.54	0.72	1287	0.60	0.80	1355	0.62	0.83	1387	0.65	0.87	1420	0.68	0.91
755	1600	1190	0.52	0.70	1228	0.55	0.74	1264	0.58	0.78	1298	0.64	0.86	1364	0.67	0.90	1397	0.69	0.93	1430	0.72	0.97
802	1700	1206	0.57	0.76	1242	0.60	0.80	1277	0.63	0.84	1310	0.66	0.88	1343	0.69	0.92	1407	0.75	1.00	1440	0.78	1.04
849	1800	1223	0.62	0.83	1257	0.65	0.87	1291	0.68	0.91	1324	0.71	0.95	1388	0.77	1.03	1420	0.81	1.08	1453	0.84	1.12
897	1900	1240	0.68	0.91	1273	0.71	0.95	1306	0.74	0.99	1338	0.77	1.03	1369	0.80	1.07	1433	0.87	1.16	1467	0.90	1.20

**BLOWER DATA**

**BELT DRIVE | 4 TON**

**BLOWER TABLE INCLUDES RESISTANCE FOR BASE UNIT ONLY WITH DRY INDOOR COIL AND AIR FILTERS IN PLACE.**

FOR ALL UNITS ADD:

1 - Any factory installed options air resistance (heat section, economizer, etc.).

2 - Any field installed accessories air resistance (duct resistance, diffuser, etc.).

See pPage 36 for blower motors and drives and wet coil and options/accessory air resistance data.

**HORIZONTAL**

Air Volume L/s cfm	External Static - Pa (in.w.g.)																													
	25 (0.10)		50 (0.20)		75 (0.30)		100 (0.40)		125 (0.50)		150 (0.60)		175 (0.70)		200 (0.80)		225 (0.9)		250 (1.0)											
	Rev/ min	kW BHP	Rev/ min	kW BHP	Rev/ min	kW BHP	Rev/ min	kW BHP	Rev/ min	kW BHP	Rev/ min	kW BHP	Rev/ min	kW BHP	Rev/ min	kW BHP	Rev/ min	kW BHP	Rev/ min	kW BHP										
425 900	493	0.09	0.12	564	0.10	0.14	637	0.13	0.17	712	0.14	0.19	788	0.16	0.21	847	0.18	0.24	894	0.20	0.27	942	0.22	0.30	993	0.25	0.33	1046	0.26	0.35
472 1000	520	0.10	0.14	589	0.13	0.17	660	0.14	0.19	733	0.16	0.21	805	0.18	0.24	861	0.20	0.27	907	0.22	0.30	954	0.25	0.33	1004	0.27	0.36	1056	0.28	0.38
519 1100	549	0.12	0.16	617	0.14	0.19	686	0.16	0.22	756	0.18	0.24	823	0.20	0.27	876	0.22	0.30	921	0.25	0.33	968	0.28	0.37	1017	0.29	0.39	1067	0.31	0.42
566 1200	582	0.14	0.19	648	0.16	0.22	714	0.19	0.25	781	0.20	0.27	843	0.22	0.30	893	0.25	0.34	938	0.28	0.37	984	0.31	0.41	1032	0.32	0.43	1081	0.34	0.46
613 1300	624	0.16	0.22	686	0.19	0.25	747	0.21	0.28	808	0.23	0.31	865	0.25	0.34	912	0.28	0.38	956	0.31	0.42	1001	0.34	0.45	1048	0.36	0.48	1096	0.37	0.50
661 1400	670	0.18	0.24	726	0.20	0.27	782	0.23	0.31	837	0.26	0.35	887	0.29	0.39	932	0.32	0.43	975	0.35	0.47	1020	0.37	0.50	1066	0.39	0.52	1112	0.41	0.55
708 1500	714	0.19	0.26	765	0.23	0.31	814	0.26	0.35	863	0.29	0.39	910	0.33	0.44	953	0.36	0.48	996	0.39	0.52	1041	0.41	0.55	1086	0.43	0.58	1130	0.46	0.61
755 1600	752	0.22	0.30	798	0.26	0.35	844	0.30	0.40	889	0.34	0.45	933	0.37	0.49	975	0.40	0.53	1018	0.43	0.57	1062	0.45	0.60	1107	0.47	0.63	1149	0.50	0.67
802 1700	785	0.26	0.35	827	0.30	0.40	871	0.34	0.46	914	0.38	0.51	957	0.41	0.55	999	0.44	0.59	1042	0.47	0.63	1085	0.49	0.66	1129	0.51	0.69	1169	0.54	0.73
849 1800	813	0.31	0.42	855	0.35	0.47	898	0.39	0.52	940	0.43	0.57	983	0.46	0.62	1025	0.49	0.66	1067	0.51	0.69	1110	0.54	0.72	1152	0.57	0.76	1190	0.60	0.80
897 1900	841	0.37	0.49	883	0.40	0.54	926	0.45	0.60	969	0.48	0.65	1011	0.51	0.69	1052	0.54	0.72	1094	0.57	0.76	1136	0.59	0.79	1176	0.62	0.83	1212	0.66	0.89
Air Volume L/s cfm	External Static - Pa (in.w.g.)																													
	275 (1.10)		300 (1.20)		325 (1.30)		350 (1.40)		375 (1.50)		400 (1.60)		425 (1.70)		450 (1.80)		475 (1.90)		500 (2.00)											
	Rev/ min	kW BHP	Rev/ min	kW BHP	Rev/ min	kW BHP	Rev/ min	kW BHP	Rev/ min	kW BHP	Rev/ min	kW BHP	Rev/ min	kW BHP	Rev/ min	kW BHP	Rev/ min	kW BHP	Rev/ min	kW BHP										
425 900	1097	0.28	0.38	1142	0.31	0.41	1182	0.32	0.43	1218	0.34	0.46	1252	0.37	0.49	1284	0.39	0.52	1314	0.41	0.55	1344	0.43	0.57	---	---	---	---	---	
472 1000	1105	0.31	0.41	1149	0.33	0.44	1190	0.35	0.47	1226	0.37	0.50	1260	0.40	0.53	1292	0.42	0.56	1322	0.44	0.59	1352	0.46	0.62	1381	0.48	0.65	1410	0.51	0.68
519 1100	1115	0.34	0.45	1158	0.36	0.48	1198	0.38	0.51	1235	0.41	0.55	1269	0.43	0.58	1301	0.46	0.61	1331	0.48	0.64	1360	0.50	0.67	1389	0.52	0.70	1418	0.54	0.73
566 1200	1126	0.37	0.49	1168	0.40	0.53	1208	0.42	0.56	1244	0.45	0.60	1278	0.47	0.63	1309	0.49	0.66	1340	0.51	0.69	1369	0.54	0.72	1398	0.56	0.75	1426	0.58	0.78
613 1300	1140	0.40	0.54	1180	0.43	0.57	1218	0.46	0.61	1254	0.48	0.65	1287	0.51	0.68	1319	0.54	0.72	1349	0.56	0.75	1378	0.58	0.78	1407	0.60	0.81	1436	0.63	0.84
661 1400	1154	0.44	0.59	1193	0.47	0.63	1230	0.50	0.67	1265	0.52	0.70	1298	0.55	0.74	1330	0.58	0.78	1360	0.60	0.81	1389	0.63	0.85	1418	0.66	0.88	1447	0.68	0.91
708 1500	1170	0.48	0.65	1208	0.51	0.69	1244	0.54	0.73	1278	0.57	0.77	1310	0.60	0.80	1341	0.63	0.84	1371	0.66	0.88	1401	0.68	0.91	1430	0.71	0.95	1459	0.73	0.98
755 1600	1187	0.53	0.71	1223	0.56	0.75	1258	0.59	0.79	1291	0.62	0.83	1323	0.65	0.87	1354	0.68	0.91	1384	0.71	0.95	1414	0.74	0.99	1443	0.76	1.02	1474	0.79	1.06
802 1700	1204	0.58	0.78	1240	0.61	0.82	1274	0.64	0.86	1306	0.67	0.90	1338	0.71	0.95	1369	0.74	0.99	1399	0.77	1.03	1429	0.79	1.06	1459	0.82	1.10	1490	0.85	1.14
849 1800	1223	0.63	0.85	1258	0.67	0.90	1291	0.70	0.94	1323	0.74	0.99	1354	0.77	1.03	1385	0.80	1.07	1415	0.83	1.11	1445	0.86	1.15	1476	0.89	1.19	1507	0.92	1.23
897 1900	1243	0.70	0.94	1277	0.74	0.99	1309	0.77	1.03	1341	0.81	1.08	1372	0.84	1.12	1402	0.87	1.16	1433	0.90	1.20	1464	0.93	1.24	1495	0.95	1.28	1527	0.98	1.32

**BLOWER DATA**

**BELT DRIVE | 5 TON**

**BLOWER TABLE INCLUDES RESISTANCE FOR BASE UNIT ONLY WITH DRY INDOOR COIL AND AIR FILTERS IN PLACE. FOR ALL UNITS ADD:**

- 1 - Any factory installed options air resistance (heat section, economizer, etc.).
- 2 - Any field installed accessories air resistance (duct resistance, diffuser, etc.).

See pPage 36 for blower motors and drives and wet coil and options/accessory air resistance data.

**DOWNFLOW**

Air Volume		External Static - Pa (in.w.g.)																													
		25 (0.10)		50 (0.20)		75 (0.30)		100 (0.40)		125 (0.50)		150 (0.60)		175 (0.70)		200 (0.80)		225 (0.90)		250 (1.00)											
L/s	cfm	Rev/min	kW	BHP	Rev/min	kW	BHP	Rev/min	kW	BHP	Rev/min	kW	BHP	Rev/min	kW	BHP	Rev/min	kW	BHP	Rev/min	kW	BHP									
519	1100	512	0.11	0.15	571	0.14	0.19	630	0.17	0.23	690	0.19	0.26	770	0.19	0.26	854	0.19	0.26	922	0.20	0.27	970	0.22	0.30	1006	0.26	0.35	1045	0.29	0.39
566	1200	535	0.13	0.18	593	0.16	0.22	651	0.19	0.26	710	0.22	0.29	788	0.22	0.30	868	0.22	0.30	933	0.23	0.31	978	0.25	0.34	1013	0.28	0.38	1053	0.31	0.42
613	1300	559	0.16	0.22	616	0.19	0.26	674	0.22	0.29	732	0.24	0.32	807	0.25	0.34	883	0.25	0.34	944	0.26	0.35	987	0.28	0.38	1022	0.31	0.42	1062	0.34	0.46
661	1400	584	0.19	0.26	641	0.22	0.29	698	0.25	0.33	755	0.27	0.36	827	0.28	0.37	899	0.28	0.38	956	0.30	0.40	997	0.32	0.43	1033	0.35	0.47	1072	0.38	0.51
708	1500	615	0.22	0.29	671	0.25	0.33	726	0.27	0.36	782	0.29	0.39	850	0.31	0.41	917	0.31	0.42	970	0.33	0.44	1009	0.35	0.47	1045	0.39	0.52	1085	0.42	0.56
755	1600	665	0.22	0.30	716	0.25	0.34	768	0.28	0.38	819	0.31	0.41	879	0.33	0.44	937	0.34	0.46	985	0.37	0.49	1022	0.39	0.52	1059	0.43	0.57	1098	0.46	0.61
802	1700	723	0.23	0.31	768	0.26	0.35	814	0.29	0.39	860	0.32	0.43	910	0.35	0.47	959	0.37	0.50	1001	0.40	0.54	1037	0.43	0.58	1074	0.46	0.62	1113	0.49	0.66
849	1800	779	0.24	0.32	818	0.28	0.37	857	0.31	0.41	897	0.34	0.46	939	0.37	0.50	980	0.41	0.55	1018	0.44	0.59	1054	0.48	0.64	1091	0.51	0.68	1129	0.54	0.72
897	1900	826	0.27	0.36	859	0.31	0.41	894	0.34	0.45	928	0.37	0.50	964	0.42	0.56	1000	0.46	0.61	1036	0.49	0.66	1072	0.52	0.70	1109	0.56	0.75	1146	0.59	0.79
944	2000	857	0.31	0.42	889	0.35	0.47	920	0.39	0.52	952	0.43	0.57	986	0.46	0.62	1020	0.51	0.68	1055	0.54	0.73	1091	0.57	0.77	1128	0.61	0.82	1164	0.64	0.86
991	2100	878	0.37	0.49	909	0.40	0.54	940	0.44	0.59	973	0.48	0.64	1006	0.52	0.70	1041	0.56	0.75	1076	0.60	0.80	1112	0.63	0.85	1148	0.66	0.89	1185	0.69	0.93
1038	2200	897	0.41	0.55	929	0.46	0.61	961	0.49	0.66	994	0.54	0.72	1028	0.58	0.78	1063	0.62	0.83	1099	0.66	0.89	1134	0.69	0.93	1170	0.72	0.97	1206	0.75	1.01
1085	2300	918	0.46	0.62	950	0.51	0.68	983	0.55	0.74	1017	0.60	0.80	1052	0.64	0.86	1087	0.69	0.92	1122	0.72	0.97	1157	0.76	1.02	1193	0.79	1.06	1228	0.81	1.09
1133	2400	941	0.52	0.70	974	0.57	0.77	1008	0.62	0.83	1042	0.67	0.90	1077	0.72	0.96	1111	0.75	1.01	1146	0.79	1.06	1181	0.83	1.11	1216	0.86	1.15	1250	0.89	1.19

Air Volume		External Static - Pa (in.w.g.)																													
		275 (1.10)		300 (1.20)		325 (1.30)		350 (1.40)		375 (1.50)		400 (1.60)		425 (1.70)		450 (1.80)		475 (1.90)		500 (2.00)											
L/s	cfm	Rev/min	kW	BHP	Rev/min	kW	BHP	Rev/min	kW	BHP	Rev/min	kW	BHP	Rev/min	kW	BHP	Rev/min	kW	BHP	Rev/min	kW	BHP									
519	1100	1089	0.32	0.43	1134	0.34	0.46	1186	0.40	0.53	1230	0.43	0.57	1266	0.45	0.60	1301	0.51	0.68	1334	0.53	0.71	1367	0.56	0.75	1400	0.62	0.83	1440	0.65	0.87
566	1200	1095	0.34	0.46	1139	0.37	0.50	1192	0.43	0.57	1234	0.45	0.60	1269	0.48	0.64	1305	0.54	0.72	1338	0.57	0.76	1372	0.60	0.80	1406	0.66	0.89	1446	0.69	0.92
613	1300	1104	0.37	0.50	1146	0.40	0.54	1199	0.46	0.61	1240	0.48	0.65	1275	0.51	0.68	1305	0.54	0.72	1344	0.60	0.81	1378	0.63	0.85	1412	0.66	0.89	1452	0.73	0.98
661	1400	1114	0.41	0.55	1155	0.43	0.58	1208	0.49	0.66	1248	0.51	0.69	1281	0.54	0.73	1311	0.57	0.77	1352	0.65	0.87	1385	0.68	0.91	1418	0.71	0.95	1459	0.78	1.05
708	1500	1125	0.45	0.60	1165	0.47	0.63	1218	0.53	0.71	1257	0.56	0.75	1290	0.59	0.79	1319	0.62	0.83	1360	0.69	0.93	1393	0.72	0.97	1426	0.75	1.01	1466	0.83	1.11
755	1600	1138	0.48	0.65	1177	0.51	0.68	1231	0.57	0.77	1268	0.60	0.80	1299	0.63	0.84	1328	0.66	0.89	1369	0.74	0.99	1402	0.78	1.04	1434	0.81	1.08	1475	0.89	1.19
802	1700	1152	0.52	0.70	1190	0.55	0.74	1231	0.57	0.77	1268	0.60	0.80	1299	0.63	0.84	1328	0.66	0.89	1369	0.74	0.99	1402	0.78	1.04	1434	0.81	1.08	1475	0.89	1.19
849	1800	1167	0.57	0.76	1205	0.60	0.80	1244	0.62	0.83	1280	0.65	0.87	1310	0.68	0.91	1338	0.71	0.95	1370	0.74	0.99	1402	0.78	1.04	1434	0.81	1.08	1475	0.89	1.19
897	1900	1183	0.61	0.82	1221	0.64	0.86	1260	0.67	0.90	1294	0.70	0.94	1323	0.73	0.98	1349	0.76	1.02	1380	0.80	1.07	1412	0.83	1.11	1443	0.86	1.15	1485	0.95	1.27
944	2000	1201	0.66	0.89	1239	0.69	0.93	1276	0.72	0.97	1310	0.75	1.01	1336	0.79	1.06	1362	0.82	1.10	1392	0.86	1.15	1423	0.89	1.19	1454	0.92	1.23	1497	1.01	1.35
991	2100	1221	0.72	0.97	1258	0.75	1.01	1294	0.78	1.05	1325	0.81	1.09	1351	0.85	1.14	1376	0.89	1.19	1406	0.92	1.23	1436	0.95	1.27	1466	0.98	1.31	1497	1.01	1.35
1038	2200	1242	0.78	1.05	1277	0.81	1.09	1311	0.85	1.14	1341	0.88	1.18	1365	0.92	1.23	1390	0.95	1.28	1420	0.98	1.32	1450	1.01	1.36	1480	1.05	1.41	1510	1.08	1.45
1085	2300	1262	0.85	1.14	1295	0.89	1.19	1327	0.93	1.24	1355	0.96	1.29	1380	0.99	1.33	1406	1.02	1.37	1435	1.06	1.42	1465	1.09	1.46	1494	1.12	1.50	1524	1.15	1.54
1133	2400	1282	0.93	1.24	1313	0.97	1.30	1343	1.01	1.36	1371	1.04	1.40	1396	1.07	1.44	1423	1.10	1.48	1452	1.13	1.52	1481	1.16	1.56	1510	1.19	1.60	1540	1.22	1.64



**BLOWER DATA**

**BELT DRIVE | 5 TON**

**BLOWER TABLE INCLUDES RESISTANCE FOR BASE UNIT ONLY WITH DRY INDOOR COIL AND AIR FILTERS IN PLACE.**

FOR ALL UNITS ADD:

- 1 - Any factory installed options air resistance (heat section, economizer, etc.).
- 2 - Any field installed accessories air resistance (duct resistance, diffuser, etc.).

See pPage 36 for blower motors and drives and wet coil and options/accessory air resistance data.

**HORIZONTAL**

Air Volume		External Static - Pa (in.w.g.)																													
		25 (0.10)		50 (0.20)		75 (0.30)		100 (0.40)		125 (0.50)		150 (0.60)		175 (0.70)		200 (0.80)		225 (0.90)		250 (1.00)											
L/s	cfm	Rev/ min	kW	BHP	Rev/ min	kW	BHP	Rev/ min	kW	BHP	Rev/ min	kW	BHP	Rev/ min	kW	BHP	Rev/ min	kW	BHP	Rev/ min	kW	BHP									
519	1100	509	0.11	0.15	562	0.13	0.18	624	0.15	0.20	691	0.16	0.22	771	0.18	0.24	852	0.19	0.25	919	0.21	0.28	970	0.23	0.31	1010	0.26	0.35	1049	0.28	0.38
566	1200	535	0.13	0.18	589	0.16	0.21	650	0.17	0.23	715	0.19	0.25	792	0.20	0.27	869	0.22	0.29	932	0.24	0.32	980	0.26	0.35	1019	0.28	0.38	1058	0.31	0.42
613	1300	564	0.16	0.21	618	0.18	0.24	678	0.20	0.27	741	0.22	0.29	815	0.23	0.31	887	0.25	0.33	946	0.27	0.36	991	0.29	0.39	1030	0.32	0.43	1068	0.35	0.47
661	1400	604	0.18	0.24	657	0.20	0.27	715	0.22	0.30	775	0.25	0.33	842	0.26	0.35	908	0.28	0.37	962	0.30	0.40	1004	0.32	0.43	1042	0.35	0.47	1080	0.38	0.51
708	1500	656	0.19	0.26	706	0.22	0.30	760	0.25	0.33	814	0.27	0.36	874	0.29	0.39	931	0.31	0.41	979	0.34	0.45	1019	0.36	0.48	1056	0.40	0.53	1094	0.43	0.57
755	1600	712	0.22	0.29	758	0.24	0.32	807	0.27	0.36	855	0.29	0.39	906	0.32	0.43	955	0.34	0.46	997	0.37	0.50	1035	0.40	0.54	1071	0.43	0.58	1109	0.46	0.62
802	1700	766	0.24	0.32	808	0.27	0.36	850	0.30	0.40	892	0.33	0.44	936	0.35	0.47	978	0.38	0.51	1016	0.42	0.56	1052	0.45	0.60	1088	0.48	0.64	1126	0.51	0.68
849	1800	814	0.27	0.36	851	0.30	0.40	888	0.33	0.44	925	0.37	0.49	963	0.40	0.53	1000	0.43	0.57	1035	0.46	0.62	1071	0.49	0.66	1107	0.52	0.70	1143	0.55	0.74
897	1900	853	0.31	0.41	886	0.34	0.46	919	0.37	0.50	952	0.41	0.55	986	0.45	0.60	1021	0.48	0.64	1056	0.51	0.69	1091	0.54	0.73	1126	0.57	0.77	1163	0.60	0.81
944	2000	883	0.36	0.48	913	0.40	0.53	944	0.43	0.57	976	0.46	0.62	1009	0.50	0.67	1043	0.53	0.71	1078	0.57	0.76	1112	0.60	0.80	1148	0.63	0.84	1183	0.66	0.88
991	2100	906	0.42	0.56	936	0.45	0.60	967	0.48	0.65	999	0.52	0.70	1033	0.56	0.75	1067	0.59	0.79	1101	0.63	0.84	1135	0.66	0.88	1170	0.69	0.92	1206	0.72	0.96
1038	2200	930	0.48	0.64	960	0.51	0.68	991	0.54	0.73	1024	0.58	0.78	1058	0.62	0.83	1092	0.66	0.88	1126	0.69	0.92	1160	0.72	0.96	1195	0.75	1.00	1230	0.78	1.04
1085	2300	954	0.54	0.72	985	0.57	0.77	1017	0.61	0.82	1051	0.65	0.87	1085	0.69	0.92	1119	0.72	0.96	1152	0.75	1.00	1186	0.78	1.04	1220	0.81	1.08	1254	0.84	1.13
1133	2400	981	0.60	0.81	1013	0.64	0.86	1046	0.68	0.91	1079	0.72	0.96	1113	0.75	1.00	1146	0.78	1.05	1180	0.81	1.09	1213	0.84	1.13	1245	0.88	1.18	1278	0.91	1.22

Air Volume		External Static - Pa (in.w.g.)																													
		275 (1.10)		300 (1.20)		325 (1.30)		350 (1.40)		375 (1.50)		400 (1.60)		425 (1.70)		450 (1.80)		475 (1.90)		500 (2.00)											
L/s	cfm	Rev/ min	kW	BHP	Rev/ min	kW	BHP	Rev/ min	kW	BHP	Rev/ min	kW	BHP	Rev/ min	kW	BHP	Rev/ min	kW	BHP	Rev/ min	kW	BHP									
519	1100	1091	0.31	0.42	1134	0.34	0.45	1176	0.36	0.48	1218	0.38	0.51	1258	0.40	0.54	1297	0.43	0.57	1335	0.44	0.59	1376	0.50	0.67	1410	0.52	0.70	1444	0.54	0.72
566	1200	1099	0.34	0.46	1141	0.37	0.49	1182	0.39	0.52	1223	0.41	0.55	1263	0.43	0.58	1302	0.46	0.61	1339	0.48	0.64	1376	0.50	0.67	1410	0.52	0.70	1449	0.58	0.78
613	1300	1108	0.37	0.50	1149	0.40	0.53	1190	0.42	0.56	1230	0.44	0.59	1270	0.47	0.63	1308	0.49	0.66	1345	0.52	0.70	1381	0.54	0.73	1415	0.56	0.75	1449	0.58	0.78
661	1400	1120	0.41	0.55	1160	0.43	0.58	1200	0.46	0.61	1240	0.48	0.65	1278	0.51	0.68	1315	0.54	0.72	1352	0.56	0.75	1387	0.58	0.78	1421	0.60	0.81	1454	0.63	0.84
708	1500	1133	0.45	0.60	1172	0.47	0.63	1212	0.50	0.67	1250	0.52	0.70	1288	0.55	0.74	1324	0.57	0.77	1360	0.60	0.81	1394	0.63	0.84	1428	0.65	0.87	1460	0.67	0.90
755	1600	1147	0.49	0.66	1186	0.51	0.69	1225	0.54	0.72	1263	0.57	0.76	1299	0.60	0.80	1334	0.62	0.83	1369	0.65	0.87	1402	0.67	0.90	1435	0.70	0.94	1467	0.72	0.96
802	1700	1164	0.54	0.72	1202	0.56	0.75	1240	0.58	0.78	1276	0.61	0.82	1311	0.64	0.86	1345	0.67	0.90	1379	0.69	0.93	1411	0.72	0.97	1443	0.75	1.00	1475	0.77	1.03
849	1800	1181	0.58	0.78	1219	0.60	0.81	1256	0.63	0.85	1291	0.66	0.89	1324	0.69	0.93	1357	0.72	0.97	1390	0.75	1.00	1421	0.78	1.04	1453	0.80	1.07	1483	0.82	1.10
897	1900	1200	0.63	0.85	1237	0.66	0.88	1273	0.69	0.92	1306	0.72	0.96	1339	0.75	1.00	1371	0.78	1.04	1402	0.81	1.08	1433	0.83	1.11	1463	0.86	1.15	1493	0.88	1.18
944	2000	1220	0.69	0.92	1257	0.72	0.96	1291	0.75	1.00	1323	0.78	1.04	1354	0.81	1.08	1385	0.84	1.12	1416	0.87	1.16	1446	0.90	1.20	1476	0.92	1.23	1505	0.94	1.26
991	2100	1242	0.75	1.00	1277	0.78	1.04	1310	0.81	1.08	1340	0.84	1.13	1371	0.87	1.17	1401	0.90	1.21	1431	0.93	1.25	1460	0.96	1.29	1489	0.98	1.32	1519	1.01	1.36
1038	2200	1265	0.81	1.08	1299	0.84	1.13	1330	0.88	1.18	1359	0.92	1.23	1388	0.95	1.27	1418	0.98	1.31	1447	1.01	1.35	1476	1.04	1.39	1504	1.06	1.42	1533	1.08	1.45
1085	2300	1288	0.87	1.17	1320	0.92	1.23	1350	0.95	1.28	1378	1.00	1.34	1406	1.03	1.38	1435	1.06	1.42	1464	1.09	1.46	1492	1.12	1.50	1521	1.14	1.53	1549	1.16	1.56
1133	2400	1311	0.95	1.28	1341	0.99	1.33	1370	1.04	1.40	1397	1.08	1.45	1425	1.12	1.50	1454	1.15	1.54	1482	1.17	1.57	1510	1.20	1.61	1538	1.22	1.64	1567	1.25	1.67

**BLOWER DATA**

**BELT DRIVE | 6 TON**

**BLOWER TABLE INCLUDES RESISTANCE FOR BASE UNIT ONLY WITH DRY INDOOR COIL AND AIR FILTERS IN PLACE.**

FOR ALL UNITS ADD:

- 1 - Any factory installed options air resistance (heat section, economizer, etc.).
- 2 - Any field installed accessories air resistance (duct resistance, diffuser, etc.).

See pPage 36 for blower motors and drives and wet coil and options/accessory air resistance data.

**DOWNFLOW**

Air Volume		External Static - Pa (in.w.g.)																										
		25 (0.10)		50 (0.20)		75 (0.30)		100 (0.40)		125 (0.50)		150 (0.60)		175 (0.70)		200 (0.80)		225 (0.90)		250 (1.00)								
L/s	cfm	Rev/ min	BHP	Rev/ min	BHP	Rev/ min	BHP	Rev/ min	BHP	Rev/ min	BHP	Rev/ min	BHP	Rev/ min	BHP	Rev/ min	BHP	Rev/ min	BHP	Rev/ min	BHP							
897	1900	480	0.28	0.38	0.51	0.33	0.44	0.54	0.38	0.51	0.43	0.57	0.63	0.48	0.52	0.70	0.68	0.57	0.76	0.71	0.62	0.83	0.75	0.66	0.89	0.78	0.71	0.95
944	2000	493	0.32	0.43	0.56	0.37	0.49	0.58	0.42	0.56	0.46	0.62	0.68	0.56	0.60	0.75	0.69	0.60	0.81	0.72	0.66	0.88	0.75	0.70	0.94	0.78	0.75	1.00
991	2100	507	0.36	0.48	0.61	0.40	0.54	0.62	0.46	0.61	0.50	0.67	0.74	0.60	0.60	0.80	0.70	0.64	0.86	0.73	0.69	0.93	0.76	0.74	0.99	0.79	0.78	1.04
1038	2200	522	0.40	0.53	0.66	0.45	0.60	0.68	0.49	0.66	0.54	0.73	0.79	0.64	0.64	0.86	0.74	0.69	0.92	0.77	0.73	0.98	0.77	0.78	1.04	0.80	0.82	1.10
1085	2300	537	0.44	0.59	0.72	0.48	0.65	0.72	0.54	0.72	0.59	0.79	0.85	0.69	0.68	0.91	0.78	0.73	0.98	0.78	0.78	1.04	0.78	0.82	1.10	0.81	0.82	1.15
1133	2400	553	0.48	0.65	0.84	0.53	0.71	0.80	0.58	0.78	0.63	0.85	0.91	0.71	0.73	0.98	0.74	0.78	1.04	0.79	0.82	1.10	0.79	0.86	1.15	0.82	0.90	1.21
1180	2500	570	0.53	0.71	0.91	0.58	0.78	0.88	0.63	0.84	0.66	0.91	0.99	0.72	0.78	1.04	0.76	0.82	1.10	0.76	0.87	1.16	0.87	0.91	1.22	0.81	0.82	1.27
1227	2600	588	0.57	0.77	0.97	0.61	0.84	0.94	0.68	0.91	0.68	0.97	1.04	0.73	0.82	1.10	0.76	0.87	1.16	0.79	0.91	1.22	0.87	0.91	1.28	0.84	0.99	1.33
1274	2700	607	0.63	0.84	1.01	0.66	0.91	1.00	0.72	0.97	0.69	0.78	1.04	0.76	0.83	1.11	0.75	0.87	1.17	0.78	0.92	1.23	0.86	0.96	1.29	0.83	0.85	1.40
1321	2800	626	0.68	0.91	1.04	0.71	0.97	1.07	0.78	1.04	0.73	0.83	1.11	0.74	0.88	1.18	0.76	0.93	1.24	0.79	0.97	1.30	0.81	1.01	1.36	0.84	1.10	1.47
1369	2900	646	0.73	0.98	1.11	0.78	1.05	1.14	0.83	1.11	0.73	0.88	1.18	0.75	0.93	1.25	0.78	0.98	1.32	0.80	1.03	1.38	0.83	1.07	1.44	0.85	1.15	1.54

Air Volume		External Static - Pa (in.w.g.)																									
		275 (1.10)		300 (1.20)		325 (1.30)		350 (1.40)		375 (1.50)		400 (1.60)		425 (1.70)		450 (1.80)		475 (1.90)		500 (2.00)							
L/s	cfm	Rev/ min	BHP	Rev/ min	BHP	Rev/ min	BHP	Rev/ min	BHP	Rev/ min	BHP	Rev/ min	BHP	Rev/ min	BHP	Rev/ min	BHP	Rev/ min	BHP	Rev/ min	BHP						
897	1900	807	0.75	1.00	1.07	0.83	1.11	1.17	0.85	1.14	0.91	1.22	1.26	0.94	1.26	0.93	1.25	1.01	1.35	1.02	1.47	1.05	1.41	1.35	1.04	1.40	1.46
944	2000	813	0.78	1.04	1.12	0.86	1.15	1.22	0.89	1.19	0.94	1.26	1.32	0.98	1.28	0.95	1.28	1.01	1.36	1.06	1.42	1.06	1.47	1.05	1.41	1.47	1.53
991	2100	820	0.81	1.09	1.17	0.89	1.21	1.29	0.93	1.24	0.95	1.28	1.37	1.02	1.37	0.98	1.30	1.01	1.43	1.06	1.42	1.06	1.47	1.05	1.41	1.47	1.60
1038	2200	828	0.85	1.14	1.22	0.93	1.26	1.34	0.97	1.30	0.97	1.30	1.40	1.07	1.39	0.98	1.32	1.01	1.48	1.06	1.48	1.06	1.54	1.05	1.41	1.47	1.67
1085	2300	836	0.90	1.20	1.28	0.98	1.31	1.39	1.01	1.35	0.96	1.35	1.44	1.08	1.45	0.96	1.35	1.01	1.50	1.06	1.55	1.06	1.61	1.05	1.41	1.47	1.76
1133	2400	846	0.93	1.25	1.33	1.02	1.37	1.45	1.05	1.41	0.97	1.37	1.47	1.10	1.52	0.96	1.37	1.01	1.57	1.06	1.63	1.06	1.61	1.05	1.41	1.47	1.84
1180	2500	856	0.98	1.31	1.39	1.07	1.43	1.50	1.10	1.47	0.98	1.39	1.49	1.13	1.59	0.96	1.39	1.01	1.63	1.06	1.69	1.06	1.61	1.05	1.41	1.47	1.93
1227	2600	866	1.03	1.38	1.46	1.12	1.50	1.58	1.15	1.54	0.98	1.40	1.50	1.19	1.67	0.96	1.40	1.01	1.71	1.06	1.78	1.06	1.61	1.05	1.41	1.47	2.03
1274	2700	878	1.07	1.44	1.52	1.17	1.57	1.65	1.20	1.61	0.99	1.41	1.51	1.25	1.75	0.96	1.41	1.01	1.81	1.06	1.89	1.06	1.61	1.05	1.41	1.47	2.13
1321	2800	889	1.13	1.51	1.59	1.22	1.64	1.72	1.26	1.69	1.00	1.43	1.53	1.31	1.84	0.96	1.43	1.01	1.91	1.06	1.99	1.06	1.61	1.05	1.41	1.47	
1369	2900	902	1.18	1.58	1.67	1.28	1.72	1.80	1.33	1.78	1.01	1.45	1.55	1.37	1.84	0.96	1.45	1.01	2.01	1.06	2.06	1.06	1.61	1.05	1.41	1.47	

**BLOWER DATA**

**BELT DRIVE | 6 TON**

**BLOWER TABLE INCLUDES RESISTANCE FOR BASE UNIT ONLY WITH DRY INDOOR COIL AND AIR FILTERS IN PLACE.**

FOR ALL UNITS ADD:

- 1 - Any factory installed options air resistance (heat section, economizer, etc.).
- 2 - Any field installed accessories air resistance (duct resistance, diffuser, etc.).

See pPage 36 for blower motors and drives and wet coil and options/accessory air resistance data.

**HORIZONTAL**

Air Volume		External Static - Pa (in.w.g.)																													
		25 (0.10)		50 (0.20)		75 (0.30)		100 (0.40)		125 (0.50)		150 (0.60)		175 (0.70)		200 (0.80)		225 (0.90)		250 (1.00)											
L/s	cfm	Rev/ min	kW	BHP	Rev/ min	kW	BHP	Rev/ min	kW	BHP	Rev/ min	kW	BHP	Rev/ min	kW	BHP	Rev/ min	kW	BHP	Rev/ min	kW	BHP									
897	1900	507	0.41	0.55	538	0.43	0.58	571	0.45	0.60	604	0.47	0.63	639	0.49	0.66	673	0.52	0.70	707	0.55	0.74	740	0.58	0.78	772	0.61	0.82	802	0.64	0.86
944	2000	522	0.44	0.59	554	0.46	0.62	586	0.48	0.64	620	0.50	0.67	653	0.53	0.71	687	0.55	0.74	720	0.58	0.78	752	0.61	0.82	783	0.65	0.87	812	0.68	0.91
991	2100	539	0.47	0.63	571	0.49	0.66	603	0.51	0.69	636	0.54	0.72	669	0.56	0.75	702	0.59	0.79	734	0.62	0.83	765	0.66	0.88	795	0.69	0.92	823	0.72	0.97
1038	2200	557	0.51	0.68	588	0.53	0.71	620	0.55	0.74	652	0.57	0.77	685	0.60	0.81	717	0.63	0.84	748	0.66	0.89	778	0.69	0.93	807	0.73	0.98	834	0.77	1.03
1085	2300	576	0.54	0.73	607	0.57	0.76	638	0.59	0.79	670	0.62	0.83	701	0.64	0.86	733	0.67	0.90	763	0.71	0.95	792	0.74	0.99	820	0.78	1.04	846	0.81	1.09
1133	2400	596	0.59	0.79	626	0.61	0.82	657	0.63	0.85	688	0.66	0.89	718	0.69	0.92	749	0.72	0.96	778	0.75	1.01	806	0.79	1.06	833	0.83	1.11	858	0.87	1.16
1180	2500	616	0.63	0.85	645	0.66	0.88	676	0.68	0.91	706	0.71	0.95	736	0.74	0.99	765	0.77	1.03	794	0.81	1.08	821	0.84	1.13	847	0.88	1.18	871	0.92	1.23
1227	2600	636	0.68	0.91	665	0.70	0.94	695	0.73	0.98	724	0.76	1.02	754	0.79	1.06	782	0.82	1.10	809	0.86	1.15	836	0.90	1.20	861	0.93	1.25	885	0.97	1.30
1274	2700	657	0.72	0.97	685	0.75	1.01	714	0.78	1.04	743	0.81	1.08	771	0.84	1.13	799	0.87	1.17	826	0.91	1.22	851	0.95	1.27	875	0.98	1.32	899	1.02	1.37
1321	2800	677	0.77	1.03	706	0.80	1.07	734	0.83	1.11	762	0.87	1.16	790	0.90	1.20	816	0.93	1.25	842	0.97	1.30	867	1.01	1.35	890	1.04	1.40	913	1.08	1.45
1369	2900	698	0.82	1.10	726	0.85	1.14	754	0.89	1.19	781	0.92	1.23	808	0.95	1.28	834	0.99	1.33	859	1.03	1.38	883	1.07	1.43	906	1.10	1.48	928	1.15	1.54
Air Volume		External Static - Pa (in.w.g.)																													
		275 (1.10)		300 (1.20)		325 (1.30)		350 (1.40)		375 (1.50)		400 (1.60)		425 (1.70)		450 (1.80)		475 (1.90)		500 (2.00)											
L/s	cfm	Rev/ min	kW	BHP	Rev/ min	kW	BHP	Rev/ min	kW	BHP	Rev/ min	kW	BHP	Rev/ min	kW	BHP	Rev/ min	kW	BHP	Rev/ min	kW	BHP									
897	1900	830	0.68	0.91	857	0.71	0.95	883	0.74	0.99	910	0.78	1.04	937	0.81	1.09	964	0.84	1.13	991	0.88	1.18	1017	0.92	1.23	1042	0.95	1.28	1067	1.00	1.34
944	2000	839	0.72	0.96	865	0.75	1.00	891	0.78	1.05	917	0.81	1.09	944	0.85	1.14	970	0.89	1.19	996	0.93	1.24	1022	0.96	1.29	1047	1.00	1.34	1071	1.04	1.40
991	2100	849	0.76	1.02	874	0.79	1.06	900	0.83	1.11	926	0.86	1.15	952	0.90	1.20	978	0.93	1.25	1003	0.97	1.30	1028	1.01	1.35	1052	1.05	1.41	1075	1.09	1.46
1038	2200	860	0.81	1.08	885	0.84	1.12	910	0.87	1.17	935	0.90	1.21	960	0.94	1.26	986	0.98	1.31	1010	1.01	1.36	1034	1.06	1.42	1058	1.10	1.48	1081	1.14	1.53
1085	2300	871	0.85	1.14	895	0.89	1.19	920	0.92	1.23	945	0.95	1.28	969	0.99	1.33	994	1.03	1.38	1018	1.07	1.43	1042	1.11	1.49	1065	1.16	1.55	1087	1.20	1.61
1133	2400	883	0.90	1.21	907	0.93	1.25	931	0.97	1.30	955	1.01	1.35	979	1.04	1.40	1003	1.08	1.45	1027	1.13	1.51	1050	1.17	1.57	1072	1.22	1.63	1094	1.26	1.69
1180	2500	895	0.95	1.28	919	0.98	1.32	942	1.02	1.37	966	1.06	1.42	990	1.10	1.48	1013	1.14	1.53	1036	1.19	1.59	1059	1.23	1.65	1081	1.28	1.71	1102	1.33	1.78
1227	2600	908	1.01	1.35	931	1.04	1.40	955	1.08	1.45	978	1.12	1.50	1001	1.16	1.56	1024	1.21	1.62	1046	1.25	1.68	1068	1.30	1.74	1089	1.34	1.80	1110	1.40	1.87
1274	2700	922	1.07	1.43	945	1.10	1.48	967	1.14	1.53	990	1.19	1.59	1013	1.23	1.65	1035	1.28	1.71	1056	1.32	1.77	1078	1.37	1.84	1099	1.42	1.90	1119	1.46	1.96
1321	2800	936	1.13	1.51	958	1.16	1.56	980	1.21	1.62	1003	1.25	1.68	1025	1.30	1.74	1046	1.34	1.80	1067	1.40	1.87	1088	1.44	1.93	1109	1.49	2.00	1129	1.54	2.06
1369	2900	950	1.19	1.60	972	1.24	1.66	994	1.28	1.72	1016	1.33	1.78	1037	1.37	1.84	1058	1.42	1.91	1079	1.47	1.97	1099	1.52	2.04	1119	1.57	2.11	1139	1.62	2.17

## BLOWER DATA

### BELT DRIVE KIT SPECIFICATIONS - 036-060

Model No.	Motor kW		Motor HP		No. of Speeds	Drive Kits and rev/min Range					
	Nom.	Max.	Nom.	Max.		A01	A02	A03	A05	A06	A07
036	0.47	0.54	0.63	0.72	2	low 374-561 high 561-842	---	---	---	---	---
	0.62	0.71	0.83	0.95	2	---	---	---	low 498-748 high 748-1122	---	---
048	0.47	0.54	0.63	0.72	2	---	low 414-621 high 621-931	---	---	---	---
	1.24	1.42	1.66	1.91	2	---	---	---	---	low 595-794 high 893-1191	---
060	0.62	0.71	0.83	0.95	2	---	---	low 463-694 high 694-1042	---	---	---
	1.24	1.42	1.66	1.91	2	---	---	---	---	---	low 673-860 high 1010-1290

NOTE - Using total air volume and system static pressure requirements determine from blower performance tables rev/min and motor output required. Maximum usable output of motors furnished are shown. If motors of comparable output are used, be sure to keep within the service factor limitations outlined on the motor nameplate.

### BELT DRIVE KIT SPECIFICATIONS - 072-074

Model No.	Motor kW		Motor HP		No. of Speeds	Drive Kits and rev/min Range		
	Nom.	Max.	Nom.	Max.		AA02	AA03	AA04
072	1.5	1.7	2	2.3	1	527-729	665-921	768-1023
074	1.2	1.4	1.7	1.9	2	527-729	665-921	768-1023

NOTE - Using total air volume and system static pressure requirements determine from blower performance tables rev/min and motor output required. Maximum usable output of motors furnished are shown. If motors of comparable output are used, be sure to keep within the service factor limitations outlined on the motor nameplate.

### FACTORY INSTALLED OPTIONS/FIELD INSTALLED ACCESSORY AIR RESISTANCE - in. w.g.

Air Volume cfm	Wet Indoor Coil						Humiditrol Dehumidification Coil	Electric Heat	Economizer	Filters	
	036		048		060, 072, 074					MERV 8	MERV 13

#### 036-048 MODELS

L/s	cfm	Pa	in. w.g.	Pa	in. w.g.	Pa	in. w.g.	Pa	in. w.g.	Pa	in. w.g.	Pa	in. w.g.	Pa	in. w.g.	Pa	in. w.g.
380	800	2	0.01	2	0.01	---	---	0	0.00	2	0.01	10	0.04	10	0.04	12	0.05
470	1000	5	0.02	5	0.02	---	---	0	0.00	7	0.03	10	0.04	10	0.04	17	0.07
565	1200	7	0.03	10	0.04	---	---	2	0.01	15	0.06	10	0.04	10	0.04	17	0.07
660	1400	10	0.04	12	0.05	---	---	5	0.02	22	0.09	10	0.04	10	0.04	17	0.07
755	1600	12	0.05	15	0.06	---	---	7	0.03	30	0.12	10	0.04	10	0.04	17	0.07
850	1800	15	0.06	17	0.07	---	---	10	0.04	37	0.15	12	0.05	10	0.04	17	0.07
945	2000	20	0.08	22	0.09	---	---	10	0.04	45	0.18	12	0.05	12	0.05	20	0.08

#### 060, 072, 074 MODELS

L/s	cfm	Pa	in. w.g.	Pa	in. w.g.	Pa	in. w.g.	Pa	in. w.g.	Pa	in. w.g.	Pa	in. w.g.	Pa	in. w.g.	Pa	in. w.g.
470	1000	---	---	---	---	5	0.02	0	0.00	2	0.01	10	0.04	7	0.03	12	0.05
565	1200	---	---	---	---	10	0.04	0	0.00	7	0.03	10	0.04	7	0.03	17	0.07
660	1400	---	---	---	---	12	0.05	2	0.01	15	0.06	10	0.04	10	0.04	17	0.07
755	1600	---	---	---	---	17	0.07	5	0.02	22	0.09	10	0.04	10	0.04	17	0.07
850	1800	---	---	---	---	20	0.08	5	0.02	30	0.12	12	0.05	12	0.05	17	0.07
945	2000	---	---	---	---	24	0.10	7	0.03	37	0.15	12	0.05	12	0.05	17	0.07
1040	2200	---	---	---	---	27	0.11	10	0.04	45	0.18	12	0.05	12	0.05	20	0.08
1135	2400	---	---	---	---	32	0.13	10	0.04	50	0.20	12	0.05	12	0.05	20	0.08
1225	2600	---	---	---	---	37	0.15	12	0.05	55	0.22	15	0.06	12	0.05	20	0.08
1321	2800	---	---	---	---	40	0.16	12	0.05	60	0.24	15	0.06	12	0.05	20	0.08
1416	3000	---	---	---	---	45	0.18	15	0.06	70	0.28	15	0.06	12	0.05	20	0.08

## BLOWER DATA

### POWER EXHAUST FAN PERFORMANCE

Return Air System Static Pressure		Air Volume Exhausted	
Pa	in. w.g.	L/s	cfm
0	0.00	787	1665
12	0.05	783	1660
25	0.10	757	1605
37	0.15	712	1510
50	0.20	654	1385
62	0.25	593	1255
75	0.30	531	1125
87	0.35	476	1010

### CEILING DIFFUSERS AIR RESISTANCE

Air Volume		RTD9-65S Step-Down Diffuser						FD9-65S Flush Diffuser		RTD11-95S Step-Down Diffuser						FD11-95S Flush Diffuser	
		2 Ends Open		1 Side & 2 Ends Open		All Ends & Sides Open				2 Ends Open		1 Side & 2 Ends Open		All Ends & Sides Open			
L/s	cfm	Pa	in. w.g.	Pa	in. w.g.	Pa	in. w.g.	Pa	in. w.g.	Pa	in. w.g.	Pa	in. w.g.	Pa	in. w.g.	Pa	in. w.g.
378	800	37	0.15	32	0.13	27	0.11	27	0.11	---	---	---	---	---	---	---	---
472	1000	47	0.19	40	0.16	35	0.14	35	0.14	---	---	---	---	---	---	---	---
566	1200	62	0.25	50	0.20	42	0.17	42	0.17	---	---	---	---	---	---	---	---
661	1400	82	0.33	65	0.26	50	0.20	50	0.20	---	---	---	---	---	---	---	---
755	1600	107	0.43	80	0.32	50	0.20	60	0.24	---	---	---	---	---	---	---	---
849	1800	139	0.56	99	0.40	75	0.30	75	0.30	32	0.13	27	0.11	22	0.09	22	0.09
944	2000	182	0.73	124	0.50	90	0.36	90	0.36	37	0.15	32	0.13	27	0.11	25	0.10
1038	2200	236	0.95	157	0.63	109	0.44	109	0.44	45	0.18	37	0.15	30	0.12	30	0.12
1133	2400	---	---	---	---	---	---	---	---	52	0.21	45	0.18	37	0.15	35	0.14
1227	2600	---	---	---	---	---	---	---	---	60	0.24	52	0.21	45	0.18	42	0.17
1321	2800	---	---	---	---	---	---	---	---	67	0.27	60	0.24	52	0.21	50	0.20
1416	3000	---	---	---	---	---	---	---	---	80	0.32	72	0.29	62	0.25	62	0.25

### CEILING DIFFUSER AIR THROW DATA

Air Volume		<sup>1</sup> Effective Throw			
L/s	cfm	m		ft.	
Model No.		RTD9-65S		FD9-65S	
378	800	3 - 5		10 - 17	
472	1000	3 - 5		10 - 17	
566	1200	3 - 5		11 - 18	
661	1400	3 - 6		12 - 19	
755	1600	3 - 6		12 - 20	
849	1800	4 - 6		13 - 21	
944	2000	4 - 7		14 - 23	
1038	2200	5 - 8		16 - 25	
Model No.		RTD11-95S		FD11-95S	
1227	2600	7 - 9		24 - 29	
1321	2800	8 - 9		25 - 30	
1416	3000	8 - 10		27 - 33	

<sup>1</sup> Effective throw based on terminal velocities of 23 m (75 ft.) per minute.

## ELECTRICAL DATA

Model No.		LCH036S4		LCH048S4		LCH060S4		LCH072H4	LCH074H4
<sup>1</sup> Voltage - 50hz 3 Phase with neutral		380/420V		380/420V		380/420V		380/420V	380/420V
Compressor	Rated Load Amps	3.7		5.1		6.2		8	8.5
	Locked Rotor Amps	31		55		55		67.1	66.1
Outdoor Fan Motor	Full Load Amps	0.6		1.1		1.3		1.3	1.3
Power Exhaust (1) 0.25 kW (0.33 HP)	Full Load Amps	1.3		1.3		1.3		1.3	1.3
Indoor Blower Motor	kW	0.47	0.62	0.47	1.24	0.62	1.24	1.5	1.24
	Full Load Amps	1.4	1.9	1.4	2.6	1.9	2.6	3.6	2.6
<sup>2</sup> Maximum Overcurrent Protection	Unit Only	15	15	15	15	15	15	20	20
	With (1) 0.25 kW (0.33 HP) Power Exhaust	15	15	15	15	15	15	20	20
<sup>3</sup> Minimum Circuit Ampacity	Unit Only	7	8	9	11	11	12	15	15
	With (1) 0.25 kW (0.33 HP) Power Exhaust	8	9	11	12	13	13	17	16

## ELECTRIC HEAT DATA

Electric Heat Voltage			420V	420V	420V	420V	420V	420V	420V	420V
<sup>2</sup> Maximum Overcurrent Protection	Unit+	5.7 kW	15	15	15	15	15	15	20	20
	<sup>4</sup> Electric Heat	11.5 kW	25	25	25	25	25	25	25	25
		17.2 kW	---	---	---	---	35	35	35	35
		23 kW	---	---	---	---	---	---	45	45
<sup>3</sup> Minimum Circuit Ampacity	Unit+	5.7 kW	12	13	12	14	13	14	15	15
	<sup>4</sup> Electric Heat	11.5 kW	22	23	22	23	23	23	25	23
		17.2 kW	---	---	---	---	32	33	35	33
		23 kW	---	---	---	---	---	---	44	43
<sup>2</sup> Maximum Overcurrent Protection	Unit+	5.7 kW	15	15	15	15	15	15	20	20
	<sup>4</sup> Electric Heat and (1) 0.25 kW (0.33 HP) Power Exhaust	11.5 kW	25	25	25	25	25	25	30	25
		17.2 kW	---	---	---	---	35	35	40	35
		23 kW	---	---	---	---	---	---	50	45
<sup>3</sup> Minimum Circuit Ampacity	Unit+	5.7 kW	14	14	14	15	14	15	17	16
	<sup>4</sup> Electric Heat and (1) 0.25 kW (0.33 HP) Power Exhaust	11.5 kW	24	24	24	25	24	25	26	25
		17.2 kW	---	---	---	---	34	35	36	35
		23 kW	---	---	---	---	---	---	46	45

<sup>1</sup> Extremes of operating range are plus and minus 10% of line voltage.

<sup>2</sup> Heating/Air Conditioning/Refrigeration (HACR) type breaker or fuse.

<sup>3</sup> Refer to local codes to determine wire, fuse and disconnect size requirements.

<sup>4</sup> Nominal kW based on 420V-3ph-50hz.

## ELECTRIC HEAT CAPACITIES

Volts Input	5.7 kW			11.5 kW			17.2 kW			23 kW		
	kW Input	Btuh Output	No. of Stages	kW Input	Btuh Output	No. of Stages	kW Input	Btuh Output	No. of Stages	kW Input	Btuh Output	No. of Stages
380	4.7	16 000	1	9.4	32 100	1	14.1	48 200	1	18.8	64 200	1
400	5.2	17 800	1	10.4	35 500	1	15.6	53 300	1	20.9	71 400	1
420	5.7	19 500	1	11.5	39 300	1	17.2	56 700	1	23.0	78 500	1

## UNIT CLEARANCES

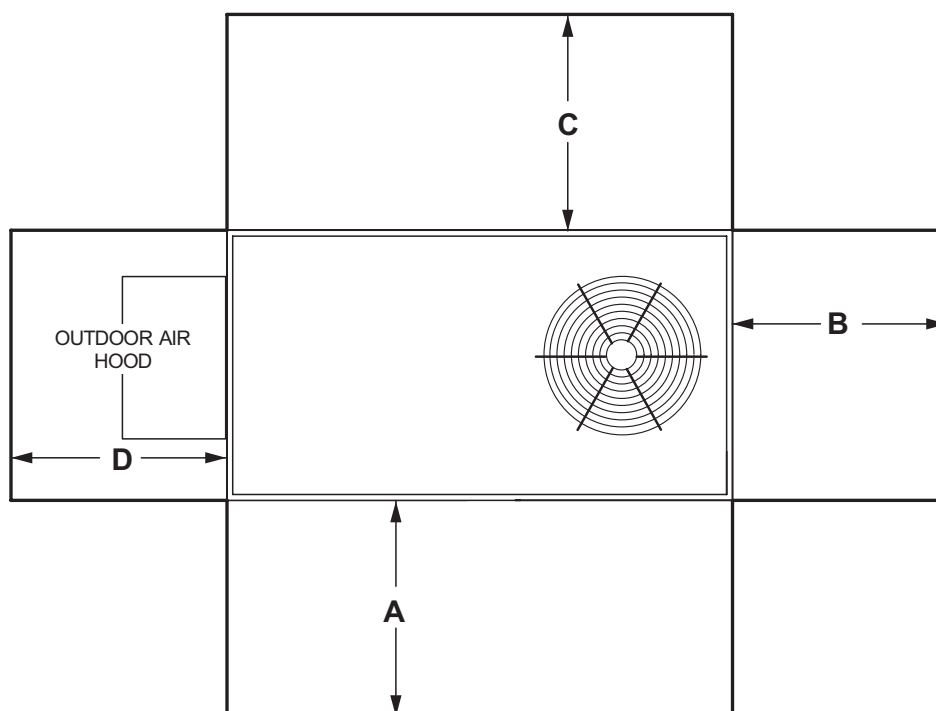

<sup>1</sup> Unit Clearance	A		B		C		D		Top Clearance
	mm	in.	mm	in.	mm	in.	mm	in.	
Service Clearance	914	36	914	36	914	36	914	36	Unobstructed
Minimum Operation Clearance	914	36	914	36	914	36	914	36	

NOTE - Entire perimeter of unit base requires support when elevated above the mounting surface.

<sup>1</sup> **Service Clearance** - Required for removal of serviceable parts.

**Minimum Operation Clearance** - Required clearance for proper unit operation.

## OUTDOOR SOUND DATA

Unit Model No.	Octave Band Sound Power Levels dBA, re 10 <sup>-12</sup> Watts Center Frequency - Hz							<sup>1</sup> Sound Rating Number (dBA)
	125	250	500	1000	2000	4000	8000	
036, 048	63	66	70	71	68	62	53	75
060, 072, 074	67	72	77	76	73	68	61	82

NOTE - The octave sound power data does not include tonal corrections.

<sup>1</sup> Sound Rating Number according to AHRI Standard 270-95 (includes pure tone penalty). The Sound Rating Number is the overall A-Weighted Sound Power Level, (L<sub>wa</sub>), dB (100 Hz to 10,000 Hz)

## WEIGHT DATA

Model Number	Outdoor Coil	Net		Shipping		Outdoor Coil	Net		Shipping	
		kg	lbs.	kg	lbs.		kg	lbs.	kg	lbs.
036 Base Unit	Environ™	233	513	260	574	Fin/Tube	241	532	269	593
036 Max. Unit	Environ™	328	723	356	784	Fin/Tube	337	742	364	803
048 Base Unit	Environ™	240	529	268	590	Fin/Tube	255	562	283	623
048 Max. Unit	Environ™	328	723	364	803	Fin/Tube	351	775	379	836
060 Base Unit	Environ™	275	607	303	668	Fin/Tube	294	649	322	710
060 Max. Unit	Environ™	383	844	410	905	Fin/Tube	402	886	430	947
072 Base Unit	Environ™	310	684	338	745	Fin/Tube	329	726	357	787
072 Max. Unit	Environ™	404	891	432	952	Fin/Tube	423	933	451	994
074 Base Unit	Environ™	310	684	338	745	Fin/Tube	329	726	357	787
074 Max. Unit	Environ™	404	891	432	952	Fin/Tube	423	933	451	994

## OPTIONS / ACCESSORIES

		Shipping Weight	
		kg	lbs.
<b>ECONOMIZER / OUTDOOR AIR / EXHAUST</b>			
<b>Economizer</b>			
Economizer, Includes Outdoor Air Hood and Barometric Relief Dampers with Hood		59	131
<b>Outdoor Air Dampers</b>			
Motorized		18	40
Manual		14	30
<b>Power Exhaust</b>			
Standard Static		17	35
<b>ELECTRIC HEAT</b>			
5.2 kW		14	31
10.4 kW		14	31
15.6 kW		16	35
20.9 kW		16	35
<b>ROOF CURBS</b>			
<b>Hybrid Roof Curbs, Downflow</b>			
203 mm height		23	50
356 mm height		32	70
457 mm height		36	80
610 mm height		45	100
<b>Adjustable Pitch Curb, Downflow</b>			
356 mm height		51	113
<b>CEILING DIFFUSERS</b>			
Step-Down	RTD9-65S	36	80
	RTD11-95S	54	118
Flush	FD9-65S	36	80
	FD11-95S	54	118
Transitions	T1TRAN10AN1	10	22
	T1TRAN20N-1	10	21
<b>HUMIDITROL® DEHUMIDIFICATION SYSTEM</b>			
Humiditrol Dehumidification (net weight)	036-048	12	27
	060-072	14	30
<b>PACKAGING</b>			
LTL Packaging (less than truck load)	036-048	27	60
	060-072	29	65



# DIMENSIONS - UNIT

## CORNER WEIGHTS

Model No.	AA		kg	BB		kg	CC		kg	DD		E.E		FF	
	kg	lbs.		kg	lbs.		kg	lbs.		kg	lbs.	mm	in.	mm	in.
LCH036 Base Unit	42	92	51	112	82	180	67	148	978	38.5	457	18			
LCH036 Max. Unit	61	133	69	151	110	243	98	215	1016	40	457	18			
LCH048 Base Unit	44	97	54	118	87	190	71	157	978	38.5	457	18			
LCH048 Max. Unit	63	139	72	158	115	254	102	224	1016	40	457	18			
LCH060 Base Unit	51	112	62	136	100	219	82	181	978	38.5	457	18			
LCH060 Max. Unit	72	159	82	180	132	290	117	257	1016	40	457	18			
LCH072 Base Unit	57	126	69	152	112	246	92	202	978	38.5	457	18			
LCH072 Max. Unit	76	168	86	190	139	306	123	270	1016	40	457	18			
LCH074 Base Unit	57	126	69	152	112	246	92	202	978	38.5	457	18			
LCH074 Max Unit	76	168	86	190	139	306	123	270	1016	40	457	18			

Base Unit - The unit with NO INTERNAL OPTIONS.

Max. Unit - The unit with ALL INTERNAL OPTIONS Installed. (Economizer, Standard Static Power Exhaust Fans, Controls, etc.). Does not include accessories external to unit or high static power exhaust.

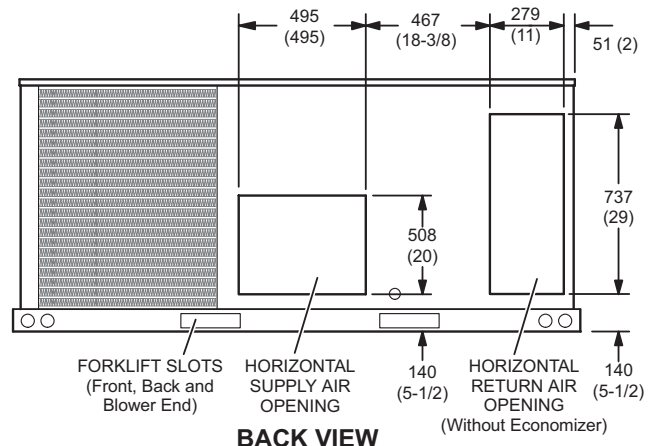
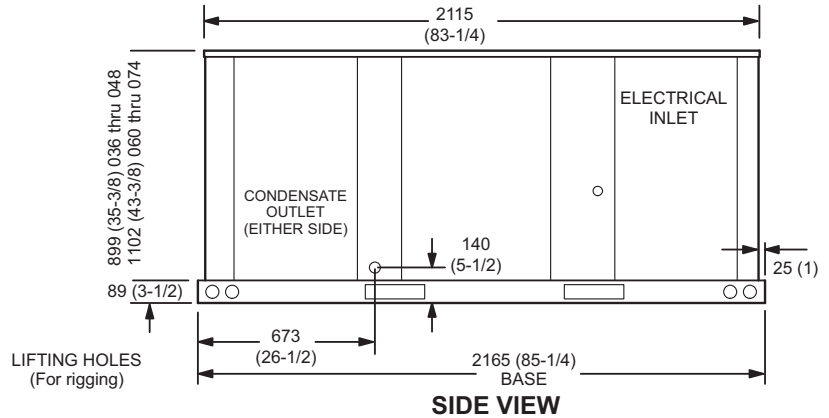
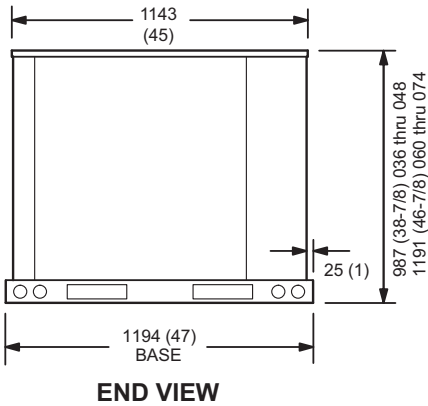
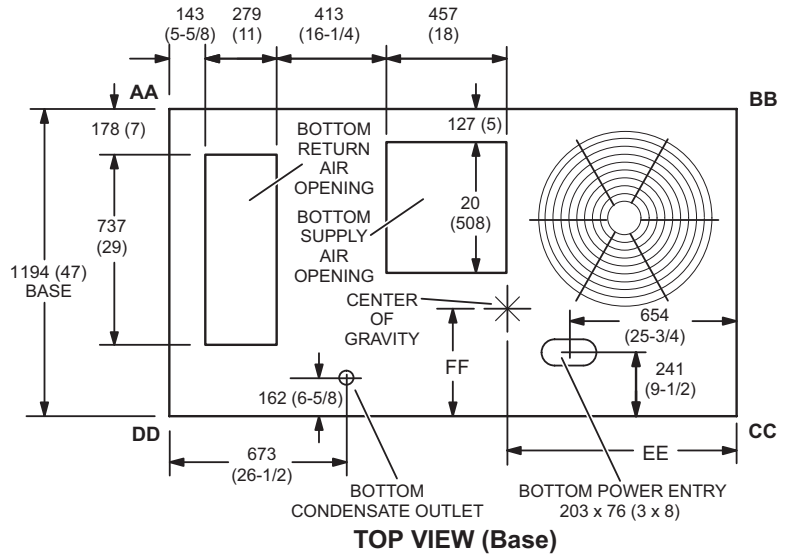

# DIMENSIONS - ACCESSORIES

## COMBINATION OUTDOOR AIR HOOD DETAIL FOR OPTIONAL ECONOMIZER AND BAROMETRIC RELIEF DAMPERS (Furnished With Economizer for Downflow Applications)

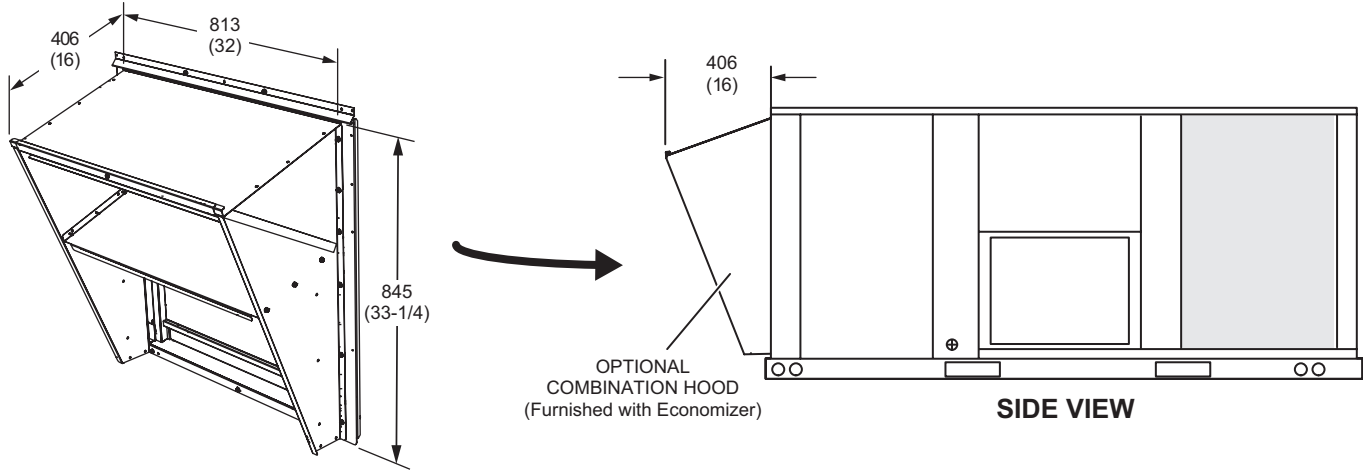

## OUTDOOR AIR DAMPER HOOD DETAIL (Downflow or Horizontal Applications)

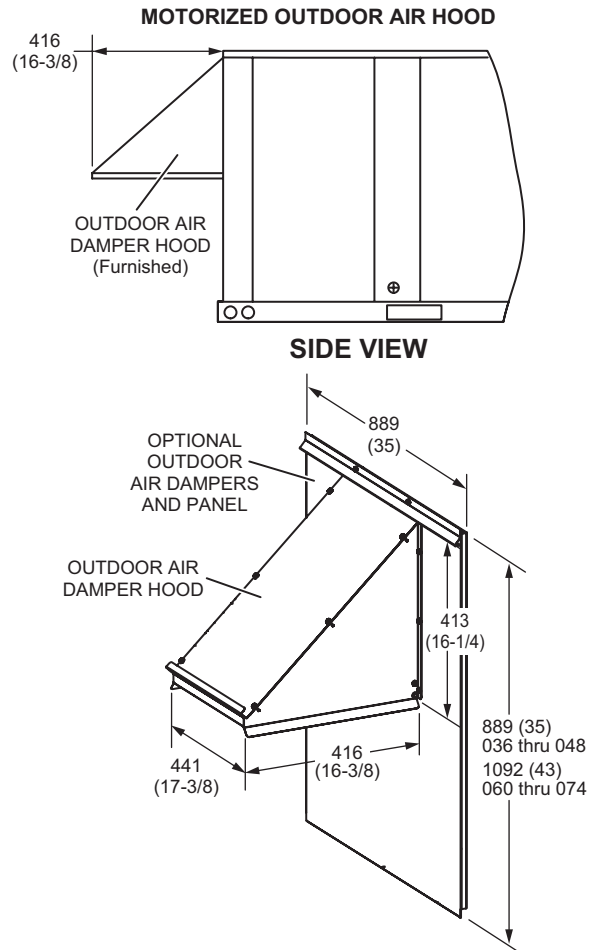
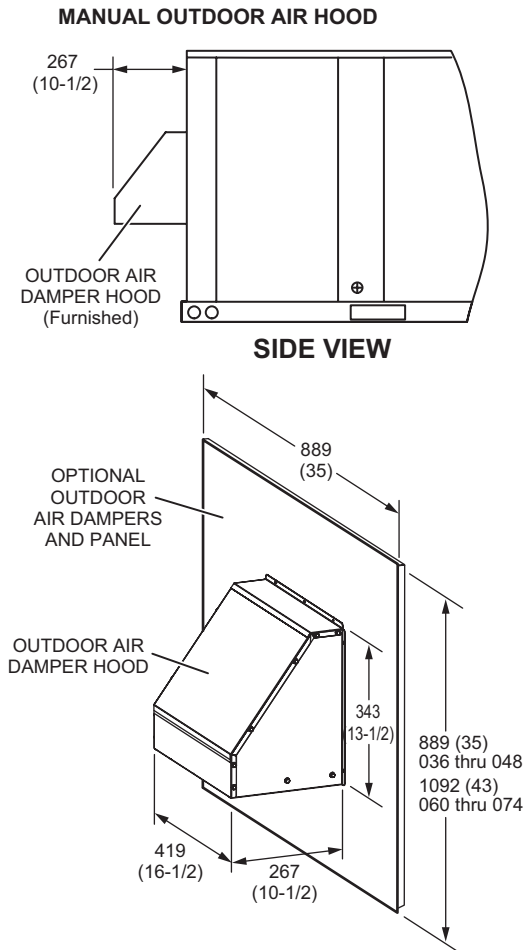

# DIMENSIONS - ACCESSORIES

## OUTDOOR AIR HOOD DETAIL WITH OPTIONAL ECONOMIZER AND OPTIONAL BAROMETRIC RELIEF DAMPERS WITH HOOD (Horizontal Application)

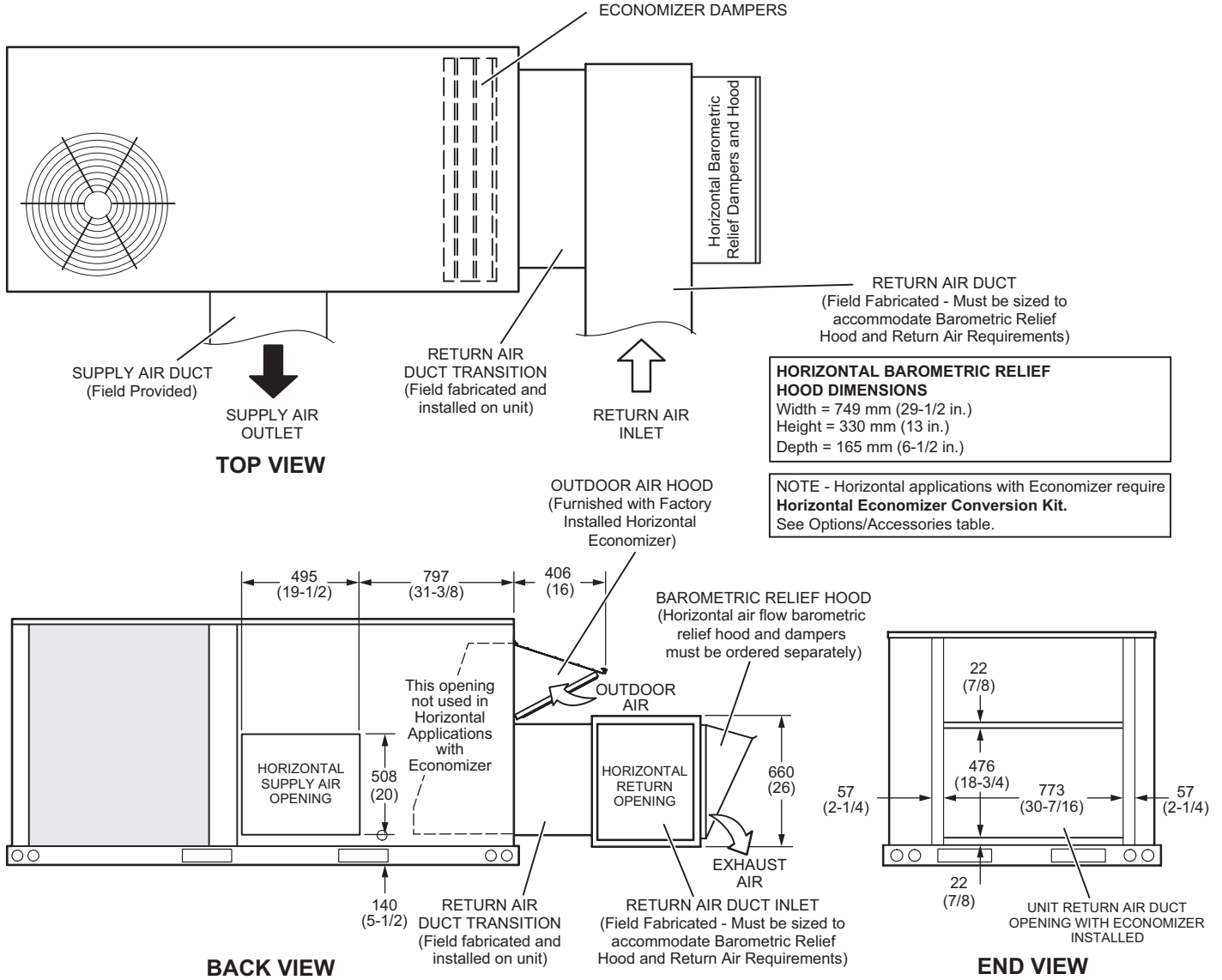

**NOTE - Return Air Duct and Transition must be supported**

# DIMENSIONS - ACCESSORIES

## HYBRID ROOF CURBS - DOUBLE DUCT OPENING

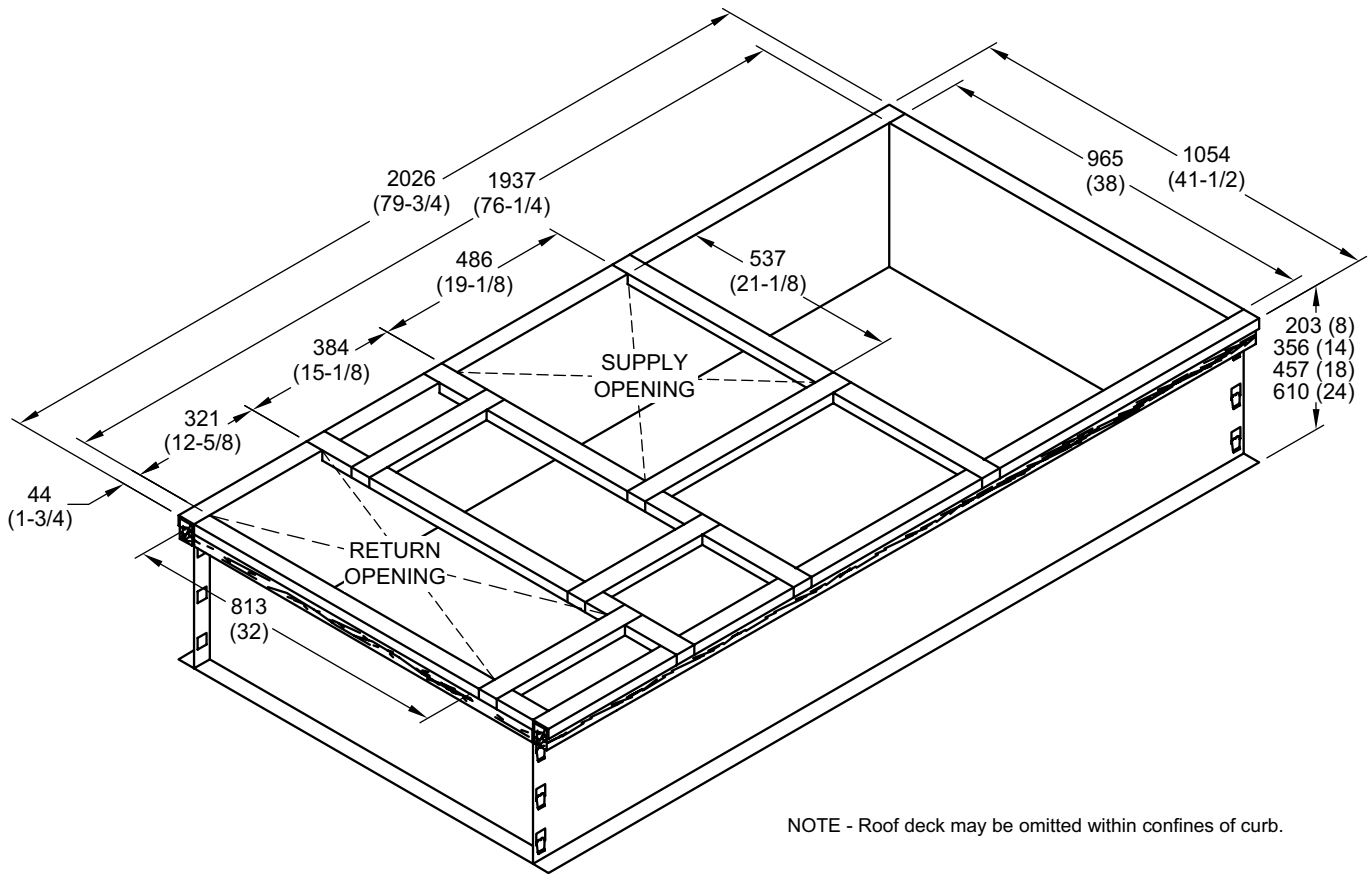

**TYPICAL FLASHING DETAIL FOR ROOF CURB**

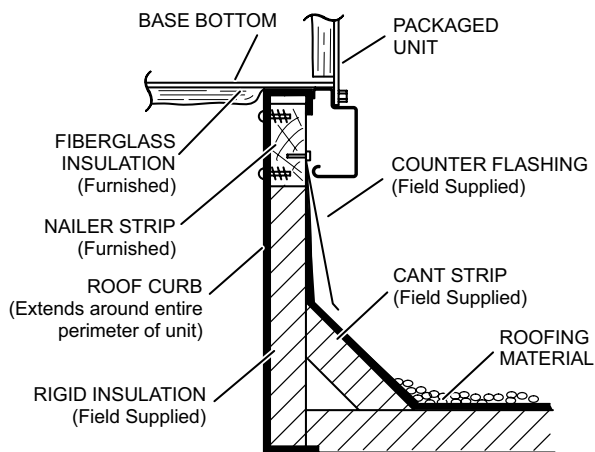

**DETAIL ROOF CURB**

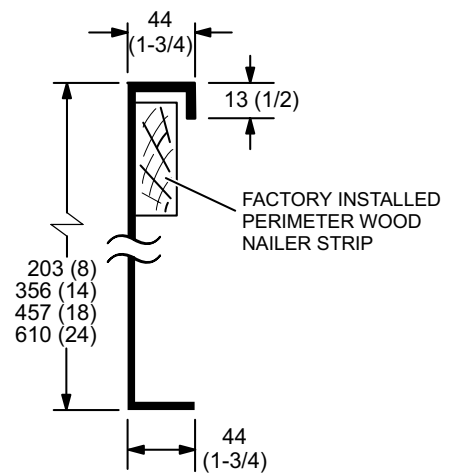

# DIMENSIONS - ACCESSORIES

## ADJUSTABLE PITCH CURBS - DOUBLE DUCT OPENING

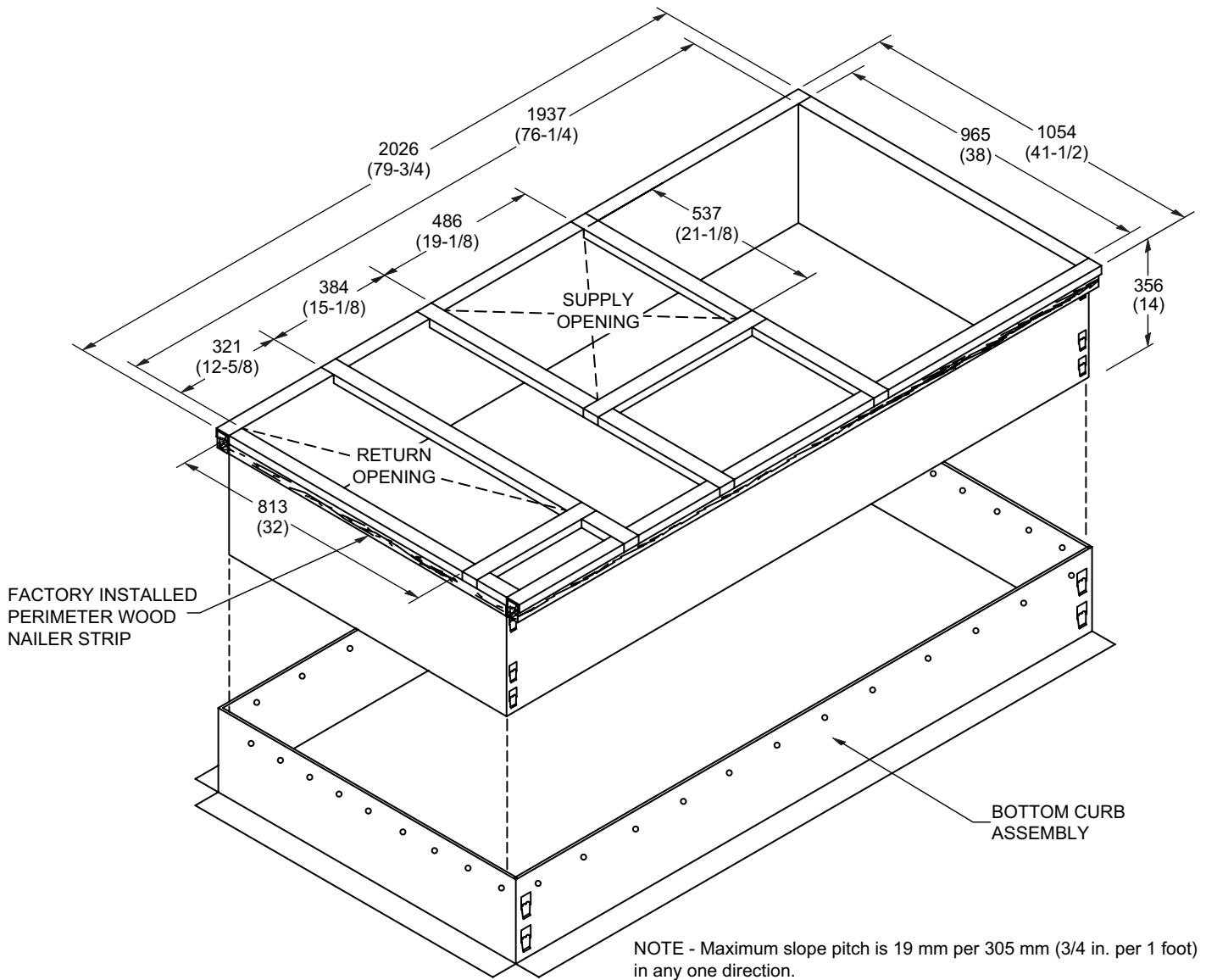

### TYPICAL FLASHING DETAIL FOR ROOF CURB

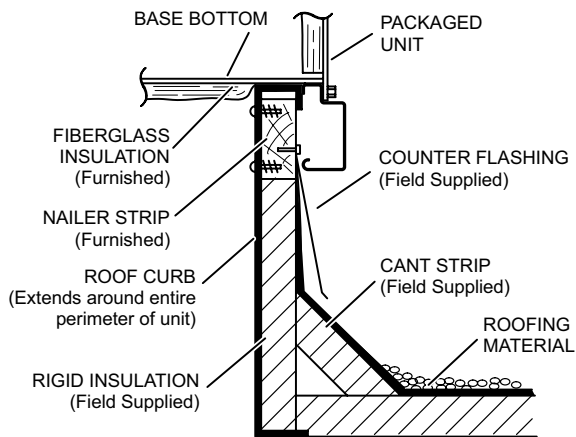

### DETAIL ROOF CURB

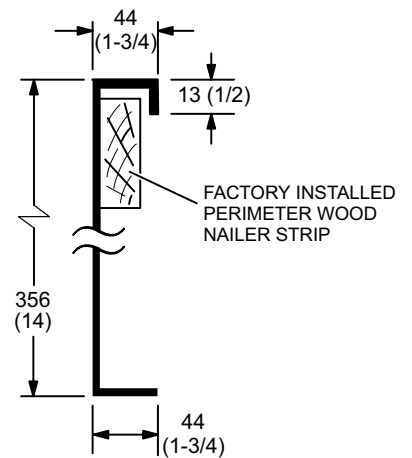

# DIMENSIONS - ACCESSORIES

## TRANSITIONS

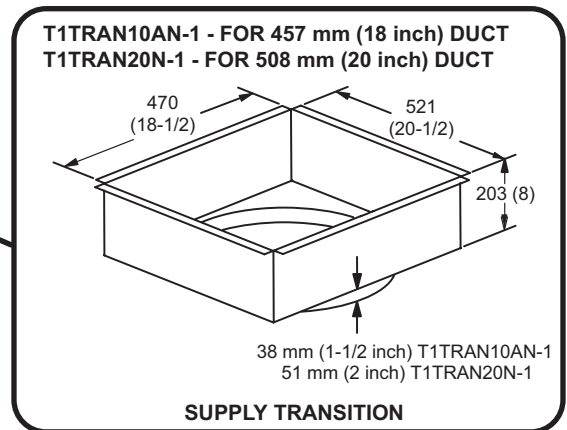
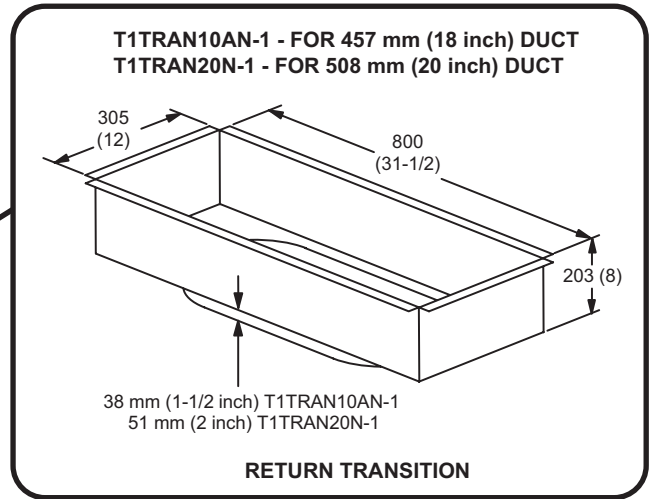
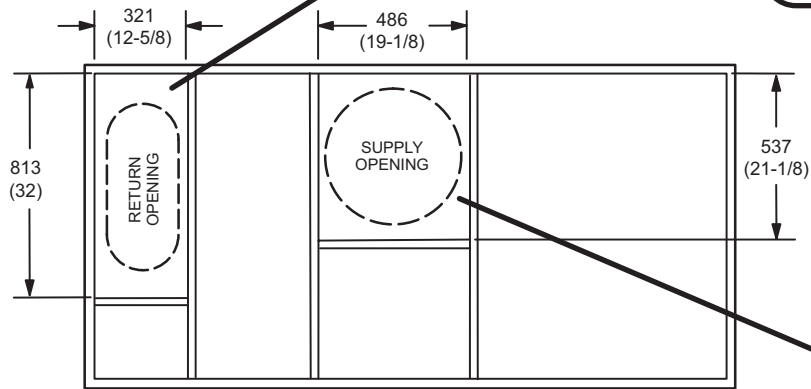

## DIMENSIONS - ACCESSORIES

### COMBINATION CEILING SUPPLY AND RETURN DIFFUSERS

#### STEP-DOWN CEILING DIFFUSER

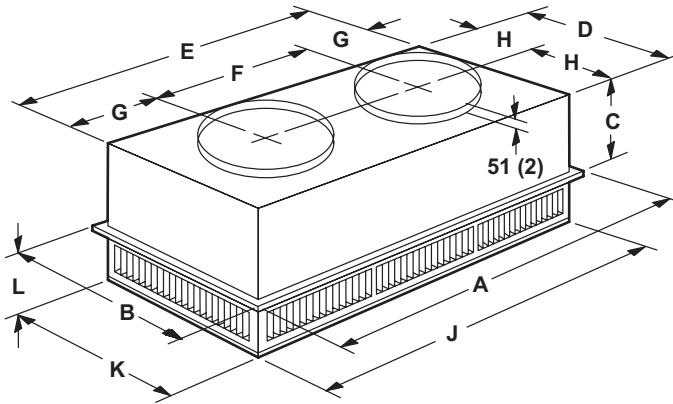

Model Number		RTD9-65S	RTD11-95S
A	mm	1159	1159
	in.	47-5/8	47-5/8
B	mm	600	752
	in.	23-5/8	29-5/8
C	mm	289	365
	in.	11-3/8	14-3/8
D	mm	546	699
	in.	21-1/2	27-1/2
E	mm	1156	1158
	in.	45-1/2	45-1/2
F	mm	572	572
	in.	22-1/2	22-1/2
G	mm	292	292
	in.	11-1/2	11-1/2
H	mm	273	349
	in.	10-3/4	13-3/4
J	mm	1156	1156
	in.	45-1/2	45-1/2
K	mm	546	699
	in.	21-1/2	27-1/2
L	mm	181	206
	in.	7-1/8	8-1/8
Duct Size	mm	457 round	508 round
	in.	18 round	20 round

#### FLUSH CEILING DIFFUSER

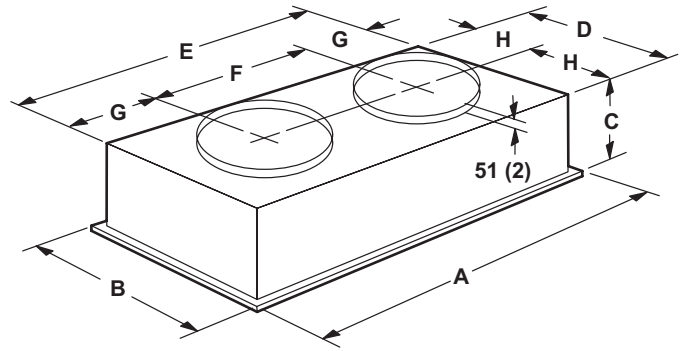

Model Number		FD9-65S	FD11-95S
A	mm	1159	1159
	in.	47-5/8	47-5/8
B	mm	600	752
	in.	23-5/8	29-5/8
C	mm	343	422
	in.	13-1/2	16-5/8
D	mm	533	686
	in.	21	27
E	mm	1143	1143
	in.	45	45
F	mm	572	572
	in.	22-1/2	22-1/2
G	mm	286	286
	in.	11-1/4	11-1/4
H	mm	267	343
	in.	10-1/2	13-1/2
Duct Size	mm	457 round	508 round
	in.	18 round	20 round

## REVISIONS

Sections	Description of Change
Options/Accessories	<b>Catalog numbers revised for:</b> Blower Proving Switch Discharge Air Temperature Switch Disconnects Economizers Electric Heat Float Switch Gravity Exhaust Dampers Power Exhaust Single Enthalpy Smoke Detectors



Visit us at [www.lennox.com](http://www.lennox.com)

For the latest technical information, [www.lennoxcommercial.com](http://www.lennoxcommercial.com)

Contact us at 1-800-4-LENNOX

NOTE - Due to our ongoing commitment to quality, Specifications, Ratings and Dimensions subject to change without notice and without incurring liability.  
Improper installation, adjustment, alteration, service or maintenance can cause property damage or personal injury.  
Installation and service must be performed by a qualified installer and servicing agency.

©2021 Lennox Industries, Inc.