



COMMERCIAL
PRODUCT SPECIFICATIONS



45.7 to 88 kW (13 to 25 Ton)
Net Cooling Capacity - 37.1 to 68 kW (127 000 to 234 000 Btuh)
Optional Electric Heat - 11.5 to 68.9 kW

MODEL NUMBER IDENTIFICATION

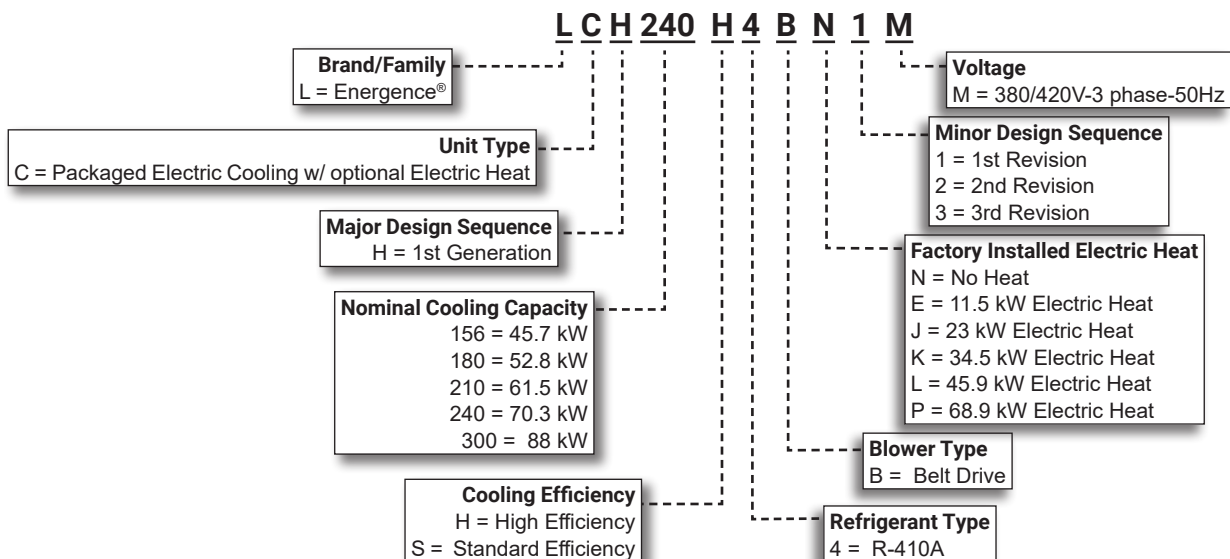

FEATURE HIGHLIGHTS

Energence® packaged rooftop unit product line was created to save energy with intelligence by offering some of the highest energy efficiency ratings available with a powerful, easy to use unit controller. This makes Energence® rooftop units perfect for business owners looking for a Heating / Ventilation / Air Conditioning (HVAC) product with the lowest total cost of ownership.

1. Scroll Compressors
2. Thermal Expansion Valves
3. Filter/Driers
4. Lennox' Environ™ Coil System
5. Outdoor Coil Fan Motors
6. Construction
7. Hinged Access Panels
8. Blower
9. Electric Heat
10. Air Filters
11. Prodigy® Control System
12. Economizer (option)
13. Downflow Barometric Relief Dampers
14. Power Exhaust Fans (option)

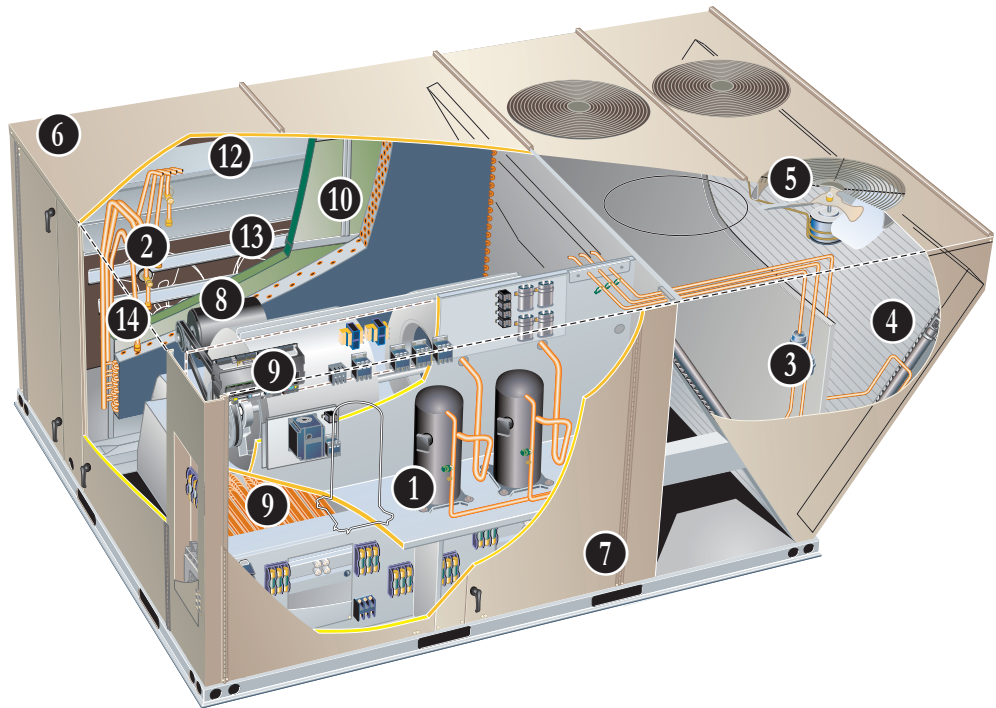

CONTENTS

Blower Data	27
Control System	6
Dimensions - Unit	34
Electrical/Electric Heat Data	31
Electric Heat Capacities	32
Features And Benefits	3
Humiditrol® Dehumidification System Ratings	24
Model Number Identification	1
Optional Conventional Temperature Control Systems	10
Options / Accessories	14
Outdoor Sound Data	32
Performance/Quality And Ce Mark Option	3
Ratings	19
Specifications	17
Unit Clearances	32
Weight Data	33

PERFORMANCE/QUALITY AND CE MARK OPTION

PERFORMANCE/QUALITY

- Components bonded for grounding to meet safety standards for servicing required by Underwriters Laboratories (UL) and the International Electrotechnical Commission (IEC)
- Cooling performance is rated at test conditions included in Air-Conditioning, Heating and Refrigeration Institute (AHRI) Standard 340/360 while operating at rated voltage and air volumes
- International Organization for Standardization (ISO) 9001 Registered Manufacturing Quality System

CE MARK OPTION

- The CE mark has been added to our rooftop product line as a configure to order (CTO) option. This optional construction allows units to be sold into countries requiring CE marking for rooftop products
- CE marked units meet the requirements of the Machinery Directive 2006/42/EC, Low Voltage Directive 73/23/EEC, EMC Directive 89/336/EEC, and Gas Directive 90/396/EEC. Declaration of conformity certificates will be provided for each CE marked unit on demand
- Key features of this option over and above standard product features are:
 - Touch-proof electrical components meeting the requirements of EN 60529
 - Branch circuits over 0.5 kW load have overcurrent protection
 - Rotary style/finger safe disconnect switch with locking handle prevents disconnect door from being opened with the power on. Padlock can be applied to lock the disconnect switch in the OFF position
 - The factory wiring has been redesigned for separation of high and low voltage circuits

FEATURES AND BENEFITS

COOLING SYSTEM

- Designed to maximize sensible and latent cooling performance at design conditions
- System can operate from -18°C to 52°C without any additional controls

R-410A Refrigerant

- Non-chlorine based
- Ozone friendly

1 Scroll Compressors

- Scroll compressors on all models for high performance, reliability and quiet operation
- Resiliently mounted on rubber grommets for quiet operation

Compressor Crankcase Heaters

- Protects against refrigerant migration that can occur during low ambient operation

2 Thermal Expansion Valves

- Ensures optimal performance throughout the application range
- Removable element head

3 Filter/Drier

- High capacity filter/drier protects the system from dirt and moisture

High Pressure Switches

- Protects the compressors from overload conditions such as dirty condenser coils, blocked refrigerant flow, or loss of outdoor fan operation

Low Pressure Switches

- Protects the compressors from low pressure conditions such as low refrigerant charge, or low/no airflow

Freezestats

- Protects the evaporator coil from damaging ice build-up due to conditions such as low/no airflow, or low refrigerant charge

4 Lennox' Environ™ Coil System

- Condenser coil features lightweight, all aluminum brazed fin construction
- Constructed of three components: a flat extrusion tube, fins in-between the flat extrusion tubes and two refrigerant manifolds

Environ™ Coil System Features:

- Improved heat transfer performance due to high primary surface area (flat tubes) versus secondary surface (fins)
- Smaller internal volume (reduced refrigerant charge)
- High durability (all aluminum construction)
- Fewer brazed joints
- Compact design (reduces unit weight)
- Easy maintenance/cleaning
- Face split design
- Mounting brackets with rubber inserts secure coil to unit providing vibration dampening and corrosion protection
- Angled design in cabinet helps protect coil from possible contact or hail damage

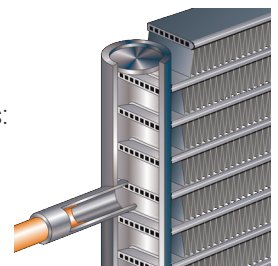

FEATURES AND BENEFITS

COOLING SYSTEM (continued)

Evaporator Coil

- Copper tube construction
- Enhanced rippled-edge aluminum fins
- Flared shoulder tubing connections
- Silver soldered construction for improved heat transfer
- Factory leak tested
- Cross row circuiting with rifled tubing optimizes both sensible and latent cooling capacity

Condensate Drain Pan

- Plastic, sloped drain pan
- Side or bottom drain connections

5 Outdoor Coil Fan Motors

- Thermal overload protected
- Totally enclosed
- Permanently lubricated ball bearings
- Shaft up
- Wire basket mount

Outdoor Coil Fans

- Polyvinyl chloride (PVC) coated fan guard furnished

Required Selections

Cooling Capacity

- Specify nominal cooling capacity of the unit

Options/Accessories

Factory Installed

Conventional Fin/Tube Condenser Coil (replaces Environ™ Coil System)

- Copper tube construction, enhanced rippled-edge aluminum fins, flared shoulder tubing connections, silver soldered construction

Service Valves

- Fully serviceable brass valves installed in discharge & liquid lines
- Not available for units equipped with Environ™ Coil System or Humiditrol Dehumidification option

Factory or Field Installed

Condensate Drain Trap

- Field installed only, may be factory enclosed to ship with unit
- Available in copper or polyvinyl chloride (PVC)

Drain Pan Overflow Switch

- Monitors condensate level in drain pan, shuts down unit if drain becomes clogged

CABINET

6 Construction

- Heavy-gauge steel panels and full perimeter heavy-gauge galvanized steel base rail provides structural integrity for transportation, handling, and installation
- Base rails have rigging holes
- Three sides of the base rail have forklift slots
- Raised edges around duct and power entry openings in the bottom of the unit provide additional protection against water entering the building

Airflow Choice

- Units are available in downflow (vertical) or horizontal return air flow configuration
- Horizontal air flow requires Horizontal Roof Curb
- Horizontal Return Air Panel Kit is also required if converting a downflow configured unit to horizontal air flow

Power Entry

- Electrical lines can be brought through the unit base or through horizontal access knock-outs

Exterior Panels

- Constructed of heavy-gauge, galvanized steel with a two-layer enamel paint finish

Insulation

- All panels adjacent to conditioned air are fully insulated with non-hygroscopic fiberglass insulation
- Unit base is fully insulated. The insulation also serves as an air seal to the roof curb, eliminating the need to add a seal during installation

7 Hinged Access Panels

- Hinged tool-less access panels are provided for the filter section, the blower section and compressor/controls section
- All hinged panels have seals and quarter-turn latching handles to provide a tight air and water seal

Required Selections

Airflow Configuration

- Specify downflow or horizontal

Options/Accessories

Factory Installed

Corrosion Protection

- A completely flexible immersed coating with an electrodeposited dry film process. (AST ElectroFin E-Coat) Meets Mil Spec MIL-P-53084, ASTM B117 Standard Method Salt Spray Testing.
- Indoor Corrosion Protection:
 - Coated coil
 - Coated reheat coil (Humiditrol)
 - Painted blower housing
 - Painted indoor base
- Outdoor Corrosion Protection
 - Coated coil
 - Painted outdoor base

FEATURES AND BENEFITS

CABINET (continued)

Field Installed

Combination Coil/Hail Guards

- Heavy gauge steel frame painted to match cabinet with expanded metal mesh to protect the outdoor coil from damage

Horizontal Return Air Panel Kit

- Required for horizontal applications with Horizontal Roof Curb, contains panel with return air opening for field replacement of existing unit panel and panel to cover bottom return air opening in unit, see dimension drawings

BLOWER

- 8 A wide selection of supply air blower options are available to meet a variety of airflow requirements

Motor

- Overload protected, equipped with ball bearings
- Belt drive motors are offered on all models and are available in several different sizes to maximize air performance

Supply Air Blower

- Forward curved blades, double inlet, blower wheel is statically and dynamically balanced. Equipped with ball bearings and adjustable pulley (allows speed change)
- Blower assembly slides out of unit for servicing
- Grease fittings furnished

Required Selections

- Specify motor output and drive kit number when base unit is ordered, see Drive Kit Specifications Table

Options/Accessories

Factory Installed

Blower Belt Auto-Tensioner

- Provides proper tension to belt drive blower belt without the need for regular adjustments
- Maintains airflow and proper performance

ELECTRICAL

- All units include terminal block and fuse block in power entry junction box for single power entry application

SmartWire™ System

- Advanced wiring connectors are keyed and color-coded to prevent miswiring
- Wire coloring scheme is standardized across all models
- Each connection is intuitively labeled to make troubleshooting and servicing quick and easy

Options/Accessories

Factory or Field Installed

9 **Electric Heat**

- Electric heat is CE marked
- Helix wound nichrome elements, individual element limit controls, wiring harness. Unit fuse block is furnished as standard
- See Options / Accessories tables for ordering information

INDOOR AIR QUALITY

10 **Air Filters**

- Disposable 51 mm filters furnished as standard

Options/Accessories

Factory or Field Installed

Healthy Climate® High Efficiency Air Filters

- Disposable MERV 8 or MERV 13 (Minimum Efficiency Reporting Value) based on American Society of Refrigeration and Air Conditioning Engineers (ASHRAE) 52.2 efficiency 51 mm pleated filters

Field Installed

Healthy Climate® UVC Germicidal Lamps

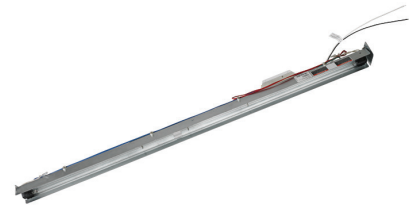

- Germicidal lamps emit ultra-violet (UV-C) energy, which has been proven to be effective in reducing microbes such as viruses, bacteria, yeasts, and molds
- This process either destroys the organism or controls its ability to reproduce
- UV-C energy greatly reduces the growth and proliferation of mold and other bioaerosols (bacteria and viruses) on illuminated surfaces (particularly coil and drain pan)
- Field installed in the blower/evaporator coil section
- Magnetic safety interlock terminates power when access panels are removed
- All necessary hardware for installation is included
- Lamps operate on 220V-1ph power supply

NOTE - Step-down transformer must be field supplied for field installation for 380/420V primary to 220V secondary.

Replacement Filter Media Kit With Frame

- Replaces existing pleated filter media
- Includes washable metal mesh screen and metal frame with clip for holding replaceable non-pleated filter

Indoor Air Quality (CO₂) Sensors

- Monitors CO₂ levels, reports to the Prodigy® unit controller which adjusts economizer dampers as needed

CONTROL SYSTEM

PRODIGY® UNIT CONTROLLER



11 The Prodigy® unit controller is a microprocessor-based control board that provides flexible control of all unit functions.

Features:

- LCD Display - Easy to read menu with buttons for menu navigation during setup and diagnostics. 4 lines x 20 character display
- Menu LEDs - Four LEDs (Data, Setup, Service, Settings) aid in menu navigation
- Main Menu and Help Buttons - Quick navigation to home screen and built-in help functions
- Scroll, Value Adjustment Select and Save Buttons
- Simplified Setup Procedure - SETUP menu insures proper installation and setup of the rooftop unit
- Profile setup copies key settings between units with the same configuration to reduce setup time
- USB Port allows a technician to download and transfer unit information to help verify service was performed
- USB drive will also allow updating software on the Prodigy® Control System to obtain enhanced functionality without the need to change components
- Unit Controller Software
- Unit self-test verifies individual critical component and system performance
- Included is an economizer test function that helps assure the economizer is operating correctly
- Time Clock with Run-time Information

Built-In Functions Include:

- Adjustable Blower On/Off Delay
- Built-in Control Parameter Defaults
- Compressor Time-Off Delay
- DDC Compatible
- Dirty Filter Switch Input
- Discharge Air Temperature Control
- Display/Sensor Readout
- Economizer Control Options (See Economizer / Exhaust Air / Outdoor Air sections)
- Fresh Air Tempering
- Over 100 diagnostic and status messages in English
- Exhaust Fan Control Modes for fresh air damper position
- Permanent Diagnostic Code Storage
- Field Adjustable Control Parameters (Over 200 settings)
- Indoor Air Quality Input (Demand Control Ventilation)
- Low Ambient Controls for cooling operation down to -17°C
- Gas Valve Time Delay Between First and Second Stage
- Minimum Compressor Run Time
- Network Capable (Can be daisy chained to other units or controls)
- Night Setback Mode
- Return Air Temperature Limit Control
- Safety Switch Input allows Controller to respond to a external safety switch trip
- Service Relay Output
- Smoke Alarm Mode has four choices (unit off, positive pressure, negative pressure, purge)
- Up to 2 heat/2 cool (standard Prodigy unit controller thermostat input)
- Up to 3 cool with additional relay
- Up to 4 cool with room sensor or network operation
- "Strike Three" Protection
- Gas Reheat Control allows simultaneous heating and cooling operation for humidity control of process air applications such as supermarkets
- On Demand Dehumidification monitors and controls condenser hot gas reheat operation with Humiditrol® dehumidification option
- Thermostat Bounce Delay
- Warm Up Mode Delay
- LED Indicators
- PC Interface connects the Prodigy 2.0 unit controller to a PC with the Lennox Unit Controller Software
- Room Sensor Operation controls temperature

NOTE - Prodigy Control System features shown vary with the type of rooftop unit in which the control is installed. **NOTE** - See separate Prodigy Control System Product Specifications Bulletin for additional information.

CONTROL SYSTEM

PRODIGY® UNIT CONTROLLER (continued)

Control Options

Factory or Field Installed

Fresh Air Tempering

- Used in applications with high outside air requirements
- Controller energizes the first stage heat as needed to maintain a minimum supply air temperature for comfort, regardless of the thermostat demand
- When ordered as a factory option, sensor ships with the unit for field installation

Smoke Detector

- Photoelectric type
- Installed in supply air section, return air section or both sections
- Available with power board and single sensor (supply or return) or power board and two sensors (supply and return)
- Power board located in unit control compartment

Interoperability via BACnet® or LonTalk® Protocols

- Communication compatible with third-party automation systems that support the BACnet Application Specific controller device profile, LonMark® Space Comfort controller functional profile, or LonMark Discharge Air controller functional profile

Commercial Control Systems

Aftermarket DDC

- Novar® ETM modules and options.

Thermostats

- Control system and thermostat options
- Aftermarket unit controller options

Field Installed

General Purpose Control Kit

- Plug-in control provides additional analog and digital inputs/outputs for field installed options

Humidity Sensor Kit

- Humidity sensor required with factory installed Humiditrol® dehumidification option or Supermarket reheat field selectable option

OPTIONS / ACCESSORIES

ECONOMIZER

- 12. Economizer operation is set and controlled by the Prodigy® unit controller

- Simple plug-in connections from economizer to unit controller for easy installation

NOTE - Optional sensors may be used instead of unit sensors to determine whether outdoor air is suitable for free cooling. See Options/Accessories table.

Factory or Field Installed

High Performance Economizer

- Gear-driven action
- High torque 24-volt fully-modulating spring return damper motor
- Return air and outdoor air dampers
- Plug-in connections to unit
- Stainless steel bearings
- Enhanced thermoplastic vulcanizate (TPV) blade edge seals
- Flexible stainless steel jamb seals to minimize air leakage

NOTE - Refer to Installation Instructions for complete setup information.

Differential Sensible Control

- Factory setting
- Uses outdoor air and return air sensors that are furnished with the unit
- The Prodigy® unit controller compares outdoor air and return air and using setpoints
- Enables the economizer when the outdoor air temperature is below the configured setpoint and cooler than return air

NOTE - Differential Sensible Control can be configured in the field to provide Offset Differential Sensible Control or Single Sensible Control.

NOTE - In Offset Differential Sensible Control mode, the economizer is enabled if the temperature differential (offset) between outdoor air and return air reaches the configured setpoint. In Single Sensible Control mode, the economizer is enabled when outdoor air temperature falls below the configured setpoint.

Global Control

- The unit controller communicates with a DDC system with one global sensor (enthalpy or sensible)
- Determines whether outside air is suitable for free cooling on all units connected to the control system
- Sensor must be field provided

ECONOMIZER (continued)

Factory or Field Installed

Single Enthalpy Temperature Control

- Outdoor air enthalpy sensor enables Economizer if the outdoor enthalpy is less than the setpoint of the control

Differential Enthalpy Control

- Order two Single Enthalpy Controls
- One is field installed in the return air section, the other in the outdoor air section
- Allows the economizer control to select between outdoor air or return air, whichever has lower enthalpy

Field Installed

Outdoor Air CFM Control

- Maintains constant outdoor air volume levels on the supply air fan and varying unit airflows
- Velocity sensor located in the rooftop unit outdoor air section, the Prodigy® unit controller changes the economizer position to help minimize the effect of supply fan speed changes on outdoor air volume levels
- Setpoint for outdoor air volume is established by field testing

NOTE - Not available with Demand Control Ventilation (CO₂ Sensor) or Building Pressure Control.

Building Pressure Control

- Maintains constant building pressure level
- Using information from a differential pressure between the outdoor air and the building air, the Prodigy® unit controller changes the economizer position to help maintain a constant building pressure

NOTE - Not available with Demand Control Ventilation (CO₂ Sensor) or Outdoor Air CFM Control.

EXHAUST

Factory or Field Installed

13 Downflow Barometric Relief Dampers

- Allow relief of excess air
- Aluminum blade dampers prevent blow back and outdoor air infiltration during off cycle
- Hood for downflow barometric relief dampers is factory installed when dampers are factory installed with economizer
- Hood is furnished with dampers when ordered for field installation
- Bird screen furnished

14 Power Exhaust Fans

- Install internal to unit for downflow applications only with economizer option
- Provides exhaust air pressure relief
- Interlocked to run when supply air blower is operating, fans run when outdoor air dampers are 50% open (adjustable), motor is overload protected
- Requires Economizer with Outdoor Air Hood and Downflow Barometric Relief Dampers
- Dual fans are 508 mm diameter with 5 blades with (2) 0.25 kW motors

Field Installed

Horizontal Barometric Relief Dampers

- For use when unit is configured for horizontal applications requiring an economizer
- Allows relief of excess air
- Aluminum blade dampers prevent blow back and outdoor air infiltration during off cycle
- Field installed in return air duct
- Bird screen and hood furnished

OPTIONS / ACCESSORIES

OUTDOOR AIR

Factory or Field Installed

Outdoor Air Damper - Downflow or Horizontal With Air Hood

Outdoor Air Damper

- Downflow or Horizontal
- Linked mechanical dampers
- 0 to 25% (fixed) outdoor air adjustable
- Installs in unit
- Includes outdoor air hood
- Automatic model features fully modulating spring return damper motor with plug-in connection
- Manual model features parallel blade, gear-driven dampers with adjustable fixed position

ROOF CURBS

- Nailer strip furnished (downflow only)
- Mates to unit
- US National Roofing Contractors Approved
- Shipped knocked down

Downflow

Hybrid Roof Curbs

- Interlocking tabs fasten corners together
- No tools required
- Can also be fastened together with furnished hardware
- Available in 203, 356, 457, and 610 mm heights

Adjustable Pitch Curb

- Fully adjustable pitch curb provides a level platform for rooftop units allowing flexible installations on roofs with uneven or sloped angles.
- Maximum slope is 19 mm per 300 mm in any direction
- Uses interlocking tabs to fasten corners together; no tools required
- Hardware is furnished to connect upper curb with lower curb
- Available in 356 mm height

Horizontal

- Converts unit from downflow to horizontal (side) air flow
- Return air is on unit
- Supply air is on curb, see dimension drawings
- Curbs for rooftop applications meet National Roofing Code requirements
- Requires Horizontal Return Air Panel Kit
- Available in 660, 762, 940 and 1041 mm heights
- Optional Insulation Kit is available to help prevent sweating

Adaptor Curbs (not shown)

- Curbs are regionally sourced
- Dimensions will vary based upon the source

NOTE - Contact your local sales representative for a detailed cut sheet with applicable dimensions.

CEILING DIFFUSERS

Ceiling Diffusers (Flush or Step-Down)

- Aluminum grilles
- Large center grille
- Insulated diffuser box with flanges
- Hanging rings furnished
- Interior transition (even air flow)
- Internally sealed (prevents recirculation)
- Adapts to T-bar ceiling grids or plaster ceilings

Transitions (Supply and Return)

- Used with diffusers
- Installs in roof curb
- Galvanized steel construction
- Langes furnished for duct connection to diffusers
- Fully insulated

OPTIONAL CONVENTIONAL TEMPERATURE CONTROL SYSTEMS

ComfortSense® 8500 Commercial 7-Day Programmable Thermostat

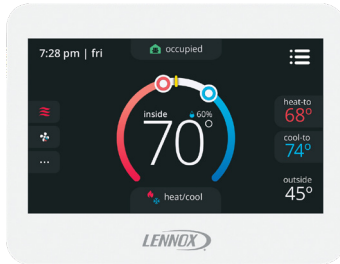

- Fully Communicating Sensor
- Full Color Touchscreen Interface
- Variable Speed System Control (On Compatible Units)
- Up To 4 Heat / 4 Cool
- Built-In Sensors For Temperature, Humidity And Optional CO₂
- Remote Sensor Options For Occupancy, Temperature
- BACnet Capable Options
- 5-2 or 7-Day Scheduling
- Smooth Setback Recovery
- Heat/Cool Auto-Changeover
- Four-Wire Installation
- FDD, ASHRAE, IECC Compliant

ComfortSense® 7500 Commercial 7-Day Programmable Thermostat



- Premium Universal Thermostat
- Full Color Touchscreen Interface
- Up To 4 Heat / 4 Cool
- Built-In Sensors For Temperature and Humidity
- Remote Sensors Options For Temperature, Discharge Air, Outdoor Air
- 5-2 or 7-Day Scheduling
- Smooth Setback Recovery
- Heat/Cool Auto-Changeover
- FDD, ASHRAE, IECC Compliant

ComfortSense® 3000 Commercial 5-2 Day Programmable Thermostat



- Conventional Multi-Stage Thermostat
- Intuitive Display
- Push-Button Operation
- Up To 2 Heat / 2 Cool
- Built-In Temperature Sensor
- Remote Temperature Sensing
- Up to 5-2 Day Scheduling
- Smooth Setback Recovery
- Heat/Cool Auto-changeover

Wired Room Sensor (LCS-5030)



- Simple Push-Button Override
- Variable Speed System Control (On Compatible Units)
- Up To 4 Heat / 4 Cool
- Built-In Temperature and Humidity Sensors
- AA Battery / 24VAC Powered
- SBUS Wired Operation
- Automatic Sensor Averaging
- Locking Hex Screw

OPTIONAL CONVENTIONAL TEMPERATURE CONTROL SYSTEMS

Description	Catalog No.
ComfortSense® 8500 Commercial 7 Day Programmable Thermostat	
CS8500 7-Day Thermostat	No CO ₂ Sensing 17G75
	With CO ₂ Sensing 17G76
Sensors/Accessories	¹ Remote non-adjustable wall-mount 10k 47W37
	¹ Remote non-adjustable wall-mount 11k 94L61
Sysbus Network Cable (Yellow) for ComfortSense 8500 and LCS-5030 Wired Room Sensor	
Twisted pair 100% shielded communication cable, Red and Black	500 ft. box 27M19
22 AWG, yellow jacket, rated at 75°C, 300V, Plenum rated	1000 ft. box 94L63
Insulation - Low smoke PVC, NEC, CMP	2500 ft. roll 68M25
ComfortSense® 7500 Commercial 7-Day Programmable Thermostat	
CS7500 7-Day Thermostat	17G74
Sensors/Accessories	² Remote non-adjustable wall-mount 20k 47W36
	² Remote non-adjustable wall-mount 10k 47W37
	Remote non-adjustable discharge air (duct mount) 19L22
	Outdoor temperature sensor X2658
ComfortSense® 3000 Commercial 5-2 Day Programmable Thermostat	
CS3000 5-2 Day Thermostat	11Y05
Sensors/Accessories	Remote non-adjustable wall mount 10k averaging 47W37
	Thermostat wall mounting plate X2659
ComfortSense® Non-Programmable Thermostat	
CS3000 Non-Programmable Thermostat	51M32
Universal Thermostat Guard with Lock (clear)	
	Inside Dimensions (H x W) 5 7/8 x 8 3/8 in. 39P21
Wired Room Sensor	
LCS-5030 Wired Room Sensor	21L07

¹ Up to nine of the same type remote temperature sensors can be connected in parallel.

² Remote wall-mount sensors can be applied in any of the following combinations:
 One Sensor - (1) 47W36, Two Sensors - (2) 47W37, Three Sensors - (2) 47W36 and (1) 47W37
 Four Sensors - (4) 47W36, Five Sensors - (3) 47W36 and (2) 47W37

HUMIDITROL® DEHUMIDIFICATION SYSTEM OPTION

OVERVIEW

- Factory installed option designed to control humidity
- Provides dehumidification on demand using American Society of Heating, Refrigeration and Air Conditioning Engineers (ASHRAE) 90.1 recommended method for comfort conditioning humidity control
- Unit comes equipped with one row reheat coil, solenoid valve and humidity controller
- In addition to a thermostat or room sensor used for conventional operation, a humidity sensor is required and must be located in the occupied space. Remote Mounted Humidity Sensor Kit is required for field installation
- The humidity sensor provides input to the unit controller which is used to control activation of the dehumidification operation
- Reheat controls are located in the compressor control section of the unit for easy access

BENEFITS

- Improves indoor air quality
- Helps prevent damage due to high humidity levels
- Improves comfort levels by reducing space humidity levels

OPERATION

No Dehumidification Demand

- The unit will operate conventionally whenever there is a demand for cooling or heating and no dehumidification demand
- Free cooling is only permitted when there is no demand for dehumidification

Dehumidification Demand Only

- The unit controller is factory set at 60% relative humidity setpoint and can be adjusted at the unit controller or with optional unit controller software
- Reheat operation will initiate on a dehumidification demand and does not require a cooling demand
- The unit will operate in the dehumidification mode until the relative humidity of the conditioned space is below the setpoint
- The reheat coil is sized to provide 20°C to 24°C supply air during reheat operation
- This reduces sensible cooling capacity and extends compressor run time to control humidity when the cooling load is low
- A solenoid valve diverts hot gas from the compressor to the reheat coil
- The cooled and dehumidified air from the evaporator is reheated as it passes through the reheat coil
- The de-superheated and partially condensed refrigerant continues to the outdoor condenser coil where condensing is completed
- The unit will continue to operate in this mode until the dehumidification demand is satisfied
- See Sequence of Operation for additional information

Dehumidification and Cooling Demand (Thermostat/ Room Sensor Application)

- If both a dehumidification and a full cooling load demand occur, the system will operate in cooling until the cooling demand is satisfied
- Then the system will energize the dehumidification mode

Options/Accessories

- Humidity Sensor Kit, Remote Mounted Humidity sensor required with factory installed Humiditrol® Option or Supermarket reheat field selectable option

HUMIDITROL® DEHUMIDIFICATION SYSTEM OPTION

REFRIGERANT SCHEMATIC (156H, 180H and 210H MODELS ONLY)

NOTE: Refrigerant circuits one and two operates when there is a first-stage thermostat demand.

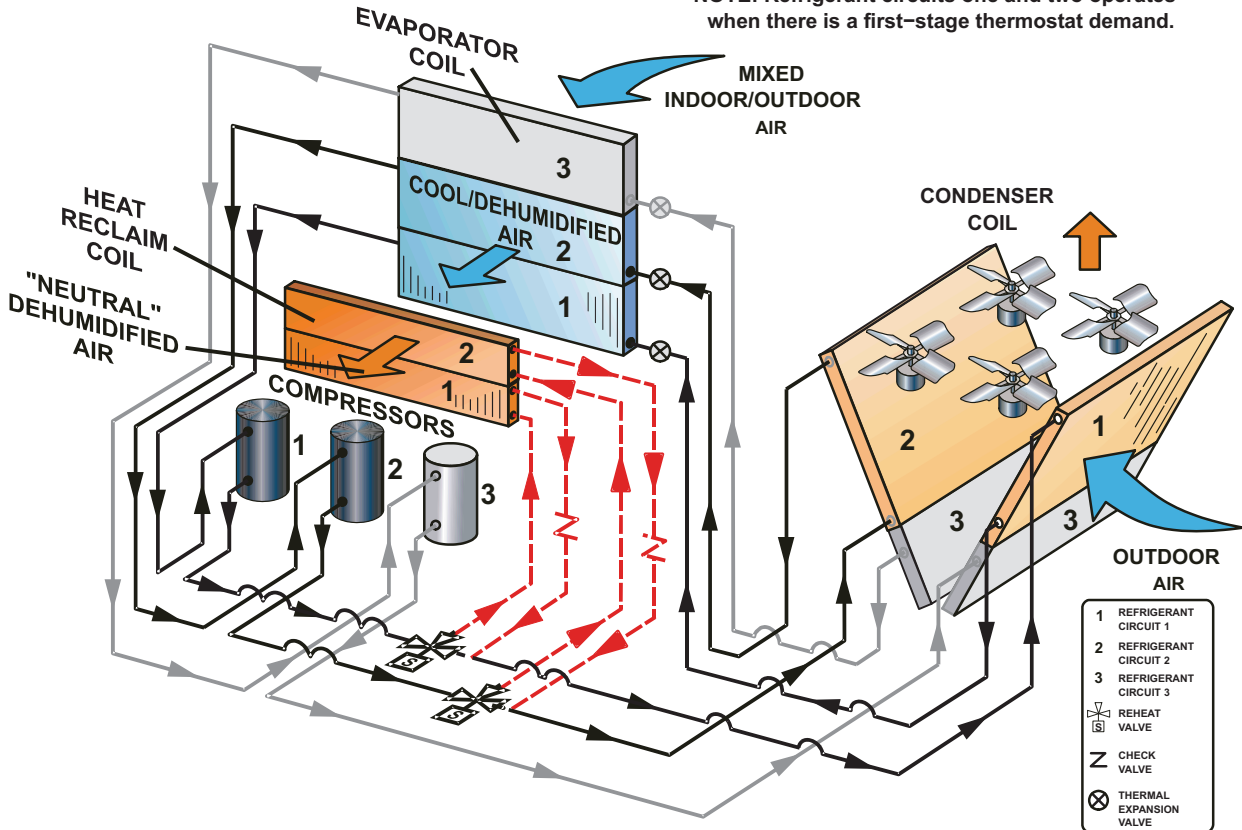

REFRIGERANT SCHEMATIC (240H and 300S MODELS ONLY)

NOTE: Refrigerant circuits one and two operates when there is a first-stage thermostat demand.

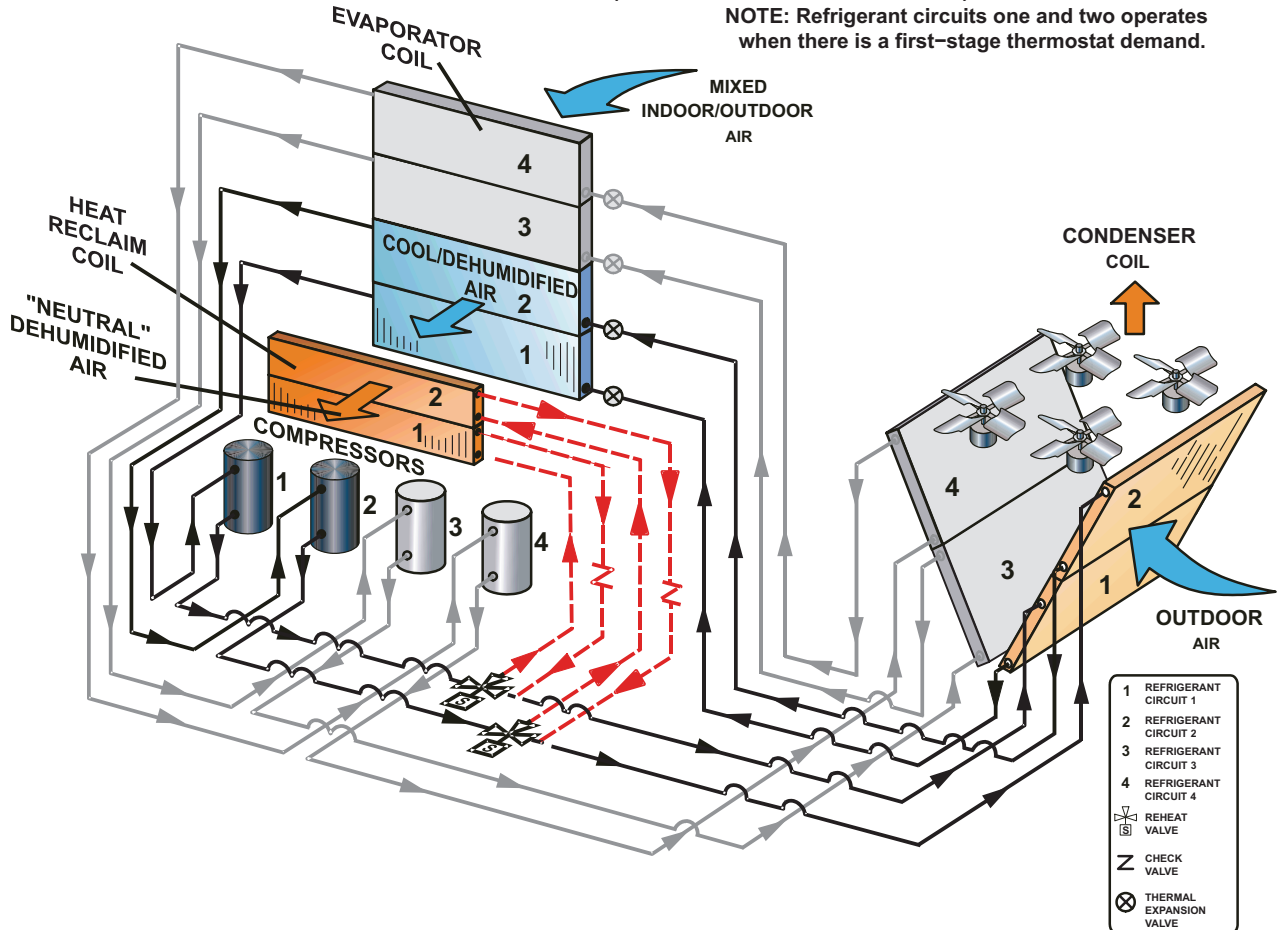

OPTIONS / ACCESSORIES

Item Description	Model Number	Catalog Number	Unit Model No				
			156	180	210	240	300
CE MARK							
CE Marked Unit		Factory	O	O	O	O	O
COOLING SYSTEM							
Condensate Drain Trap	Polyvinyl Chloride (PVC) - C1TRAP20AD2	22H54	OX	OX	OX	OX	OX
	Copper - C1TRAP10AD2	76W27	OX	OX	OX	OX	OX
Conventional Fin/Tube Condenser Coil (replaces Environ™ Coil System)			O	O	O	O	O
Corrosion Protection		Factory	O	O	O	O	O
Drain Pan Overflow Switch	E1SNSR71AD1	21Z07	OX	OX	OX	OX	OX
Efficiency	High		O	O	O	O	
	Standard						O
Refrigerant Type		R-410A	O	O	O	O	O
Service Valves (not for Environ™ Coil System or Humiditrol® Dehumidification equipped units)		Factory	O	O	O	O	O
BLOWER - SUPPLY AIR							
Motors	Belt Drive - 1.5 kW	Factory	O				
	Belt Drive - 2.2 kW	Factory	O	O	O		
	Belt Drive - 3.7 kW	Factory	O	O	O	O	O
	Belt Drive - 5.6 kW	Factory		O	O	O	O
	Belt Drive - 7.5 kW	Factory				O	O
Drive Kits	Kit #1 446-604 rev/min	Factory	O				
See Blower Data Tables for usage and selection	Kit #2 571-721 rev/min	Factory	O				
	Kit #3 571-721 rev/min	Factory	O	O	O	O	O
	Kit #4 708-871 rev/min	Factory	O	O	O	O	O
	Kit #5 788-988 rev/min	Factory	O	O	O	O	O
	Kit #6 708-871 rev/min	Factory		O	O	O	O
	Kit #7 788-988 rev/min	Factory		O	O	O	O
	Kit #8 871-1071 rev/min	Factory		O	O	O	O
	Kit #10 871-1071 rev/min	Factory				O	O
	Kit #11 945-1138 rev/min	Factory				O	O
	Blower Belt Auto-Tensioner	Factory	O	O	O	O	O
	CABINET						
Combination Coil/ Hail Guards	Environ™ Coil System - C1GARD52C12	15T92	X				
	Environ™ Coil System - C1GARD52C22	15T93		X	X	X	X
	Conventional Fin/Tube Condenser Coil - C1GARD51C11	13T08	X				
	Conventional Fin/Tube Condenser Coil - C1GARD51C21	13T12		X	X	X	X
CONTROLS							
Blower Proving Switch	C1SNSR35FF1	21Z10	OX	OX	OX	OX	OX
Commercial Controls	Prodigy® Control System - BACnet® Module - C0CTRL60AE1L	59W51	OX	OX	OX	OX	OX
	Prodigy® Control System - LonTalk® Module - C0CTRL65FF1	54W27	OX	OX	OX	OX	OX
	Novar® LSE	Factory	O	O	O	O	O
Dirty Filter Switch	E1SNSR55C-1	53W68	OX	OX	OX	OX	OX
General Purpose Control Kit	E1GPBK30C1	13J78	X	X	X	X	X
Fresh Air Tempering	C1SNSR75AD1	21Z08	OX	OX	OX	OX	OX
Smoke Detector - Supply or Return (Power board and one sensor)	C1SNSR44C-1	83W40	OX	OX	OX	OX	OX
Smoke Detector - Supply and Return (Power board and two sensors)	C1SNSR43C-1	83W41	OX	OX	OX	OX	OX

NOTE - Catalog and model numbers shown are for ordering field installed accessories.

OX - Configure To Order (Factory Installed) or Field Installed

O = Configure To Order (Factory Installed)

X = Field Installed

OPTIONS / ACCESSORIES

Item Description	Model Number	Catalog Number	Unit Model No				
			156	180	210	240	300
INDOOR AIR QUALITY							
Air Filters							
Healthy Climate® High Efficiency Air Filters 610 x 610 x 51 mm (Order 6 per unit)	MERV 8 - C1FLTR15C-1-	54W67	OX	OX	OX	OX	OX
	MERV 13 - C1FLTR40C-1-	52W40	OX	OX	OX	OX	OX
Replacement Media Filter With Metal Mesh Frame (includes non-pleated filter media)	C1FLTR30C-1-	44N61	OX	OX	OX	OX	OX
Indoor Air Quality (CO₂) Sensors							
Sensor - Wall-mount, off-white plastic cover with LCD display	C0SNSR50AE1L	77N39	X	X	X	X	X
Sensor - Wall-mount, off-white plastic cover, no display	C0SNSR52AE1L	87N53	X	X	X	X	X
Sensor - Black plastic case with LCD display, rated for plenum mounting	C0SNSR51AE1L	87N52	X	X	X	X	X
Sensor - Wall-mount, black plastic case, no display, rated for plenum mounting	C0MISC19AE1	87N54	X	X	X	X	X
CO ₂ Sensor Duct Mounting Kit - for downflow applications	C0MISC19AE1-	85L43	X	X	X	X	X
Aspiration Box - for duct mounting non-plenum rated CO ₂ sensors (87N53 or 77N39)	C0MISC16AE1-	90N43	X	X	X	X	X
UVC Germicidal Light Kit							
¹ Healthy Climate® UVC Light Kit (220V-1ph)	C1UVCL10C-1	21A94	X	X	X	X	X
ELECTRICAL							
Voltage 50 Hz with neutral (No neutral on CE marked models)	380/420V - 3 phase	Factory	O	O	O	O	O
² ELECTRIC HEAT							
11.5 kW	380/420V-3ph - C1EH0115C-1M	67W96	OX	OX	OX	OX	OX
23 kW	380/420V-3ph - C1EH0230C11M	67W97	OX				
	380/420V-3ph - C1EH0230C21M	67W98		OX	OX	OX	OX
34.5 kW	380/420V-3ph - C1EH0345C11M	67W99	OX				
	380/420V-3ph - C1EH0345C21M	68W00		OX	OX	OX	OX
45.9 kW	380/420V-3ph - C1EH0459C11M	68W01	OX				
	380/420V-3ph - C1EH0459C21M	68W02		OX	OX	OX	OX
68.9 kW	380/420V-3ph - C1EH0689C-1M	68W03			OX	OX	OX
ECONOMIZER							
High Performance Economizer							
High Performance Economizer Downflow or Horizontal - Includes Outdoor Air Hood. Order Downflow or Horizontal Barometric Relief Dampers separately.	E1ECON17C-2	16Y98	OX	OX	OX	OX	OX
Economizer Controls							
Differential Enthalpy	Order 2 - C1SNSR64FF1	21Z09	OX	OX	OX	OX	OX
Sensible Control	Sensor is Furnished	Factory	O	O	O	O	O
Single Enthalpy	C1SNSR64FF1	21Z09	OX	OX	OX	OX	OX
Global Control	Sensor Field Provided	Factory	O	O	O	O	O
Building Pressure Control	E1GPBK20C1	13J77	X	X	X	X	X
Outdoor Air CFM Control	E1GPBK10C1	13J76	X	X	X	X	X
Barometric Relief Dampers With Exhaust Hood							
Downflow Barometric Relief Dampers	C1DAMP50C	54W78	OX	OX	OX	OX	OX
Horizontal Barometric Relief Dampers	LAGEDH18/24	16K99	X	X	X	X	X

¹ Lamps operate on 220V single-phase power supply. Step-down transformer must be field supplied for field installation for 380/420V primary to 220V secondary. Alternately, a separate 220V power supply may be used to directly power the UVC ballast(s).

² Nominal kW at 420V-3ph-50hz.

NOTE - Catalog and model numbers shown are for ordering field installed accessories.

OX - Configure To Order (Factory Installed) or Field Installed

O = Configure To Order (Factory Installed)

X = Field Installed

OPTIONS / ACCESSORIES

Item Description	Model Number	Catalog Number	Unit Model No				
			156	180	210	240	300
OUTDOOR AIR							
Outdoor Air Dampers With Outdoor Air Hood							
Motorized	C1DAMP20C-1	13U04	OX	OX	OX	OX	OX
Manual	C1DAMP10C-2	13U05	OX	OX	OX	OX	OX
¹ POWER EXHAUST (DOWNFLOW APPLICATIONS ONLY)							
Standard Static	380/420V - C1PWRE11C-1M	75W93	OX	OX	OX	OX	OX
HUMIDITROL® CONDENSER REHEAT OPTION							
Humiditrol® Dehumidification Option		Factory	O	O	O	O	O
Humidity Sensor Kit, Remote mounted (required)	COSNSR31AE-1	17M50	X	X	X	X	X
ROOF CURBS							
Hybrid Roof Curbs, Downflow							
203 mm height	C1CURB70C-1	11F58	X	X	X	X	X
356 mm height	C1CURB71C-1	11F59	X	X	X	X	X
457 mm height	C1CURB72C-1	11F60	X	X	X	X	X
610 mm height	C1CURB73C-1	11F61	X	X	X	X	X
Adjustable Pitch Curb, Downflow							
356 mm height	L1CURB55C	43W26	X	X	X	X	X
Standard Roof Curbs, Horizontal - Requires Horizontal Return Air Panel Kit							
660 mm height - slab applications	C1CURB14C-1	11T89	X	X	X	X	
940 mm height - rooftop applications	C1CURB15C-1	11T96	X	X	X	X	
762 mm height - slab applications	C1CURB16C-1	11T90					X
1041 mm height - rooftop applications	C1CURB17C-1	11T97					X
Insulation Kit For Standard Horizontal Curbs							
for C1CURB14C-1 (660 mm)	C1INSU11C-1-	73K32	X	X	X	X	
for C1CURB15C-1 (762 mm)	C1INSU12C-1-	73K33					X
for C1CURB16C-1 (940 mm)	C1INSU13C-1-	73K34	X	X	X	X	
for C1CURB17C-1 (1041 mm)	C1INSU14C-1-	73K35					X
Horizontal Return Air Panel Kit							
Required for Horizontal Applications with Roof Curb	C1HRAP10C-1-	87M00	X	X	X	X	X
CEILING DIFFUSERS							
Step-Down - Order one	RTD11-185S	13K63	X	X			
	RTD11-275S	13K64			X	X	X
Flush - Order one	FD11-185S	13K58	X	X			
	FD11-275S	13K59			X	X	X
Transitions (Supply and Return) - Order one	C1DIFF33C-1	12X68	X	X			
	C1DIFF34C-1	12X70			X	X	X

¹ Field installed Power Exhaust requires Economizer with Outdoor Air Hood and Barometric Relief Dampers with Exhaust Hood. Must be order separately.

NOTE - Catalog and model numbers shown are for ordering field installed accessories.

OX - Configure To Order (Factory Installed) or Field Installed

O = Configure To Order (Factory Installed)

X = Field Installed

SPECIFICATIONS

General Data		Nominal kW (Tons)	45.7 (13)	52.8 (15)	61.5 (17.5)	
Model Number			LCH156H4B	LCH180H4B	LCH210H4B	
Efficiency Type			High	High	High	
Blower Type			CAV (Constant Air Volume)	CAV (Constant Air Volume)	CAV (Constant Air Volume)	
Cooling Performance	Gross Cooling Capacity - kW (Btuh)		38.7 (132 000)	44.8 (153 000)	51.3 (175 000)	
	¹ Net Cooling Capacity - kW (Btuh)		37.1 (127 000)	43.4 (148 000)	49.5 (169 000)	
	AHRI Rated Air Flow - L/s (cfm)		2360 (5000)	2475 (5250)	2890 (6125)	
	Total Unit Power - kW		10.4	12.1	13.9	
	¹ EER (Btuh/Watt) at 35°C (95°F)		12.2	12.2	12.2	
	² EER (Btuh/Watt) at 46°C (115°F)		8.1	8.2	8.2	
	¹ IEER (Btuh/Watt)		13.2	13.5	13.0	
Refrigerant Charge		Refrigerant Type	R-410A	R-410A	R-410A	
Environ™ Coil System	Circuit 1		2.61 kg (5 lbs. 12 oz.)	2.72 kg (6 lbs. 0 oz.)	3.06 kg (6 lbs. 12 oz.)	
		Circuit 2	2.49 kg (5 lbs. 4 oz.)	2.55 kg (5 lbs. 10 oz.)	3.12 kg (6 lbs. 14 oz.)	
		Circuit 3	2.55 kg (5 lbs. 10 oz.)	2.66 kg (5 lbs. 14 oz.)	3.12 kg (6 lbs. 14 oz.)	
	Environ™ Coil With Humiditrol®	Circuit 1	2.66 kg (5 lbs. 14 oz.)	2.95 kg (6 lbs. 8 oz.)	3.29 kg (7 lbs. 4 oz.)	
		Circuit 2	2.27 kg (5 lbs. 8 oz.)	2.61 kg (5 lbs. 12 oz.)	3.18 kg (7 lbs. 0 oz.)	
		Circuit 3	2.61 kg (5 lbs. 12 oz.)	2.98 kg (6 lbs. 9 oz.)	2.83 kg (6 lbs. 4 oz.)	
	Conventional Fin/Tube Coil Option	Circuit 1	4.54 kg (10 lbs. 0 oz.)	5.67 kg (12 lbs. 8 oz.)	5.90 kg (13 lbs. 0 oz.)	
		Circuit 2	4.54 kg (10 lbs. 0 oz.)	5.67 kg (12 lbs. 8 oz.)	5.90 kg (13 lbs. 0 oz.)	
		Circuit 3	4.31 kg (9 lbs. 8 oz.)	5.67 kg (12 lbs. 8 oz.)	5.90 kg (13 lbs. 0 oz.)	
	Conventional Fin/Tube With Humiditrol® Dehumidification Option	Circuit 1	5.44 kg (12 lbs. 0 oz.)	6.58 kg (14 lbs. 8 oz.)	6.80 kg (15 lbs. 0 oz.)	
		Circuit 2	5.44 kg (12 lbs. 0 oz.)	6.58 kg (14 lbs. 8 oz.)	6.80 kg (15 lbs. 0 oz.)	
		Circuit 3	4.31 kg (9 lbs. 8 oz.)	5.67 kg (12 lbs. 8 oz.)	5.90 kg (13 lbs. 0 oz.)	
	Electric Heat Available - See page 33			11.5, 23, 34.5, 45.9 kW		11.5, 23, 34.5, 45.9, 68.9 kW
	Compressor Type (number)			Scroll (3)	Scroll (3)	Scroll (3)
	Outdoor Coils	Net face area (total) - m ² (sq. ft.)		3.85 (41.4)	5.13 (55.2)	5.13 (55.2)
No. of rows Environ™ (Fin/Tube)			1 (2)	1 (2)	1 (2)	
Environ™ Fin/Tube	Fins per m (Fins per inch)		906 (23)/ 787 (20)	906 (23)/ 787 (20)	906 (23)/ 787 (20)	
	Outdoor Coil Fans	Motor - (No.) W (HP)	(3) 250 (1/3)	(4) 250 (1/3)	(6) 250 (1/3)	
	Motor rev/min (watts)		896 (840)	896 (1146)	896 (1490)	
	Diameter - (No.) mm (in.)		(3) 610 (24)	(4) 610 (24)	(6) 610 (24)	
	Number of blades		3	3	3	
	Total Air volume - L/s (cfm)		4270 (10 000)	6293 (13 333)	7866 (16 666)	
Indoor Coils	Net face area (total) - m ² (sq. ft.)		1.99 (21.4)	1.99 (21.4)	1.99 (21.4)	
	Tube diameter - mm (in.)		9.5 (3/8)	9.5 (3/8)	9.5 (3/8)	
	Number of rows		3	3	4	
	Fins per m (Fins per inch)		551 (14)	551 (14)	551 (14)	
	Drain connection - No. and size		(1) 1 in. FPT	(1) 1 in. FPT	(1) 1 in. FPT	
	Expansion device type		Balance port TXV, removable head			
³ Indoor Blower and Drive Selection	Nominal Motor kW (HP)		1.5 (2)	2.2 (3)	2.2 (3)	
	Maximum usable motor kW (HP)		1.7 (2.3)	2.6 (3.45)	2.6 (3.45)	
	Kit # (rev/min range)	#1 (446-604)		#3 (571-721)	#3 (571-721)	
		#2 (571-721)		#4 (708-871)	#4 (708-871)	
	Nominal Motor kW (HP)			2.2 (3)	3.7 (5)	3.7 (5)
		Maximum usable motor kW (HP)		2.6 (3.45)	4.3 (5.75)	4.3 (5.75)
	Kit # (rev/min range)	#3 (571-721)		#3 (571-721)	#3 (571-721)	
		#4 (708-871)		#4 (708-871)	#4 (708-871)	
	Nominal Motor kW (HP)			3.7 (5)	5.6 (7.5)	5.6 (7.5)
		Maximum usable motor kW (HP)		4.3 (5.75)	6.4 (8.6)	6.4 (8.6)
	Kit # (rev/min range)	#3 (571-721)		#4 (708-871)	#6 (708-871)	
		#4 (708-871)		#5 (788-988)	#7 (788-988)	
	#5 (788-988)		#8 (871-1071)	#8 (871-1071)		
Blower wheel nominal diameter x width - mm (in.)			(2) 381 x 381 (15 x 15)			
Filters Type of filter - Number and size - mm (in.)			Fiberglass, disposable - (6) 610 x 610 x 51 (24 x 24 x 2)			
Electrical Characteristics			380/420V - 50 hertz - 3 phase with neutral (No neutral on CE marked models)			

NOTE - Net capacity includes evaporator blower motor heat deduction. Gross capacity does not include evaporator blower motor heat deduction.

¹ Tested at conditions which are based on AHRI Standard 340/360; 35°C (95°F) outdoor air temperature and 27°C (80°F) db/19°C (67°F) wb entering evaporator air; minimum external duct static pressure while operating at rated voltage and air volumes.

² Rated at 46°C (115°F) outdoor air temperature and 27°C (80°F) db/19°C (67°F) wb entering evaporator air (T3 Conditions).

³ Using total air volume and system static pressure requirements determine from blower performance tables rev/min and motor output required. Maximum usable output of motors furnished are shown. See Belt Drive Specification Table for maximum usable motor output. If motors of comparable output are used, be sure to keep within the service factor limitations outlined on the motor nameplate.

SPECIFICATIONS

General Data		Nominal kW (Tons)	70.3 (20)	88 (25)	
		Model Number	LCH240H4B	LCH300S4B	
		Efficiency Type	High	Standard	
		Blower Type	Constant Air Volume CAV	Constant Air Volume CAV	
Cooling Performance	Gross Cooling Capacity - kW (Btuh)		60.1 (205 000)	71.8 (245 000)	
	¹ Net Cooling Capacity - kW (Btuh)		58.0 (198 000)	68.6 (234 000)	
	AHRI Rated Air Flow - L/s (cfm)		3020 (6400)	3965 (8400)	
	Total Unit Power - kW		16.2	21.9	
	¹ EER (Btuh/Watt) at 35°C (95°F)		12.2	10.7	
	² EER (Btuh/Watt) at 46°C (115°F)		8.2	7.7	
	¹ IEER (Btuh/Watt)		13.2	11.2	
		Refrigerant Type	R-410A	R-410A	
Refrigerant Charge	Environ™ Coil System	Circuit 1	2.84 kg (6 lbs. 4 oz.)	2.84 kg (6 lbs. 4 oz.)	
		Circuit 2	2.78 kg (6 lbs. 2 oz.)	2.55 kg (5 lbs. 10 oz.)	
		Circuit 3	2.66 kg (5 lbs. 14 oz.)	2.89 kg (6 lbs. 6 oz.)	
		Circuit 4	2.44 kg (5 lbs. 6 oz.)	2.72 kg (6 lbs. 0 oz.)	
	Environ™ Coil With Humiditrol®	Circuit 1	2.84 kg (6 lbs. 4 oz.)	3.40 kg (7 lbs. 8 oz.)	
		Circuit 2	2.55 kg (5 lbs. 10 oz.)	2.84 kg (6 lbs. 4 oz.)	
		Circuit 3	2.21 kg (4 lbs. 14 oz.)	2.78 kg (6 lbs. 2 oz.)	
		Circuit 4	2.21 kg (4 lbs. 14 oz.)	2.66 kg (5 lbs. 14 oz.)	
	Conventional Fin/Tube Coil Option	Circuit 1	4.54 kg (10 lbs. 0 oz.)	4.76 kg (10 lbs. 8 oz.)	
		Circuit 2	4.54 kg (10 lbs. 0 oz.)	4.53 kg (10 lbs. 0 oz.)	
		Circuit 3	4.54 kg (10 lbs. 0 oz.)	4.42 kg (9 lbs. 12 oz.)	
		Circuit 4	3.97 kg (8 lbs. 12 oz.)	4.42 kg (9 lbs. 12 oz.)	
	Conventional Fin/Tube With Humiditrol® Dehumidification Option	Circuit 1	5.44 kg (12 lbs. 0 oz.)	5.78 kg (12 lbs. 12 oz.)	
		Circuit 2	5.44 kg (12 lbs. 0 oz.)	5.32 kg (11 lbs. 12 oz.)	
		Circuit 3	4.54 kg (10 lbs. 0 oz.)	4.42 kg (9 lbs. 12 oz.)	
		Circuit 4	3.97 kg (8 lbs. 12 oz.)	4.42 kg (9 lbs. 12 oz.)	
	Electric Heat Available - See page 33			11.5, 23, 34.5, 45.9, 68.9 kW	
	Compressor Type (number)			Scroll (4)	Scroll (4)
	Outdoor Coils	Net face area (total) - m ² (sq. ft.)		5.13 (55.2)	5.13 (55.2)
		No. of rows Environ™ (Fin/Tube)		1 (2)	1 (2)
Environ™ Fin/Tube	Fins per m (Fins per inch)		906 (23)/	787 (20)/	
			787 (20)	787 (20)	
Outdoor Coil Fans	Motor - (No.) W (HP)		(6) 250 (1/3)	(6) 250 (1/3)	
	Motor rev/min (watts)		896 (1490)	896 (1490)	
	Diameter - (No.) mm (in.)		(6) 610 (24)	(6) 610 (24)	
	Number of blades		3	3	
	Total Air volume - L/s (cfm)		7866 (16 666)	7866 (16 666)	
	Indoor Coils	Net face area (total) - m ² (sq. ft.)		1.99 (21.4)	1.99 (21.4)
Tube diameter - mm (in.)			9.5 (3/8)	9.5 (3/8)	
Number of rows			4	4	
Fins per m (Fins per inch)			551 (14)	551 (14)	
Drain connection - No. and size			(1) 1 in. FPT	(1) in. FPT	
Expansion device type			Balance port TXV, removable head		
³ Indoor Blower and Drive Selection	Nominal Motor kW (HP)		3.7 (5)	3.7 (5)	
	Maximum usable motor kW (HP)		4.3 (5.75)	4.3 (5.75)	
	Kit # (rev/min range)		#3 (571-721)	#3 (571-721)	
			#4 (708-871)	#4 (708-871)	
			#5 (788-988)	#5 (788-988)	
	Nominal Motor kW (HP)		5.6 (7.5)	5.6 (7.5)	
		Maximum usable motor kW (HP)		6.4 (8.6)	6.4 (8.6)
		Kit # (rev/min range)		#6 (708-871)	#6 (708-871)
			#7 (788-988)	#7 (788-988)	
			#8 (871-1071)	#8 (871-1071)	
	Nominal Motor kW (HP)		7.5 (10)	7.5 (10)	
		Maximum usable motor kW (HP)		8.6 (11.5)	8.6 (11.5)
		Kit # (rev/min range)		#7 (788-988)	#7 (788-988)
			#10 (871-1071)	#10 (871-1071)	
	#11 (945-1138)		#11 (945-1138)		
Blower wheel nominal diameter x width - mm (in.)			(2) 381 x 381 (15 x 15)		
Filters	Type of filter - Number and size - mm (in.)		Fiberglass, disposable - (6) 610 x 610 x 51 (24 x 24 x 2)		
Electrical characteristics			380/420V - 50 hertz - 3 phase with neutral (No neutral on CE marked models)		

NOTE - Net capacity includes evaporator blower motor heat deduction. Gross capacity does not include evaporator blower motor heat deduction.

¹ Tested at conditions which are based on AHRI Standard 340/360; 35°C (95°F) outdoor air temperature and 27°C (80°F) db/19°C (67°F) wb entering evaporator air; minimum external duct static pressure while operating at rated voltage and air volumes.

² Rated at 46°C (115°F) outdoor air temperature and 27°C (80°F) db/19°C (67°F) wb entering evaporator air (T3 Conditions).

³ Using total air volume and system static pressure requirements determine from blower performance tables rev/min and motor output required. Maximum usable output of motors furnished are shown. See Belt Drive Specification Table for maximum usable motor output. If motors of comparable output are used, be sure to keep within the service factor limitations outlined on the motor nameplate.

RATINGS

NOTE – For Temperatures and Capacities not shown in tables, see bulletin – Cooling Unit Rating Table Correction Factor Data in Miscellaneous Engineering Data section.

45.7 kW - LCH156H4 (1ST STAGE)

Entering Wet Bulb Temperature	Total Air Volume	Outdoor Air Temperature Entering Outdoor Coil																			
		18.3°C					23.9°C					29.4°C					35°C				
		Total Cool Cap.	Comp. Motor Input	Sensible To Total Ratio (S/T)			Total Cool Cap.	Comp. Motor Input	Sensible To Total Ratio (S/T)			Total Cool Cap.	Comp. Motor Input	Sensible To Total Ratio (S/T)			Total Cool Cap.	Comp. Motor Input	Sensible To Total Ratio (S/T)		
				Dry Bulb					Dry Bulb					Dry Bulb					Dry Bulb		
L/s	kW	kW	24°C	27°C	29°C	kW	kW	24°C	27°C	29°C	kW	kW	24°C	27°C	29°C	kW	kW	24°C	27°C	29°C	
17.2°C	1965	28.6	3.87	0.71	0.85	0.99	26.6	4.38	0.71	0.86	1.00	24.6	4.94	0.72	0.88	1.00	22.5	5.57	0.72	0.91	1.00
	2455	30.3	3.9	0.76	0.93	1.00	28.2	4.41	0.77	0.95	1.00	26.1	4.97	0.78	0.97	1.00	24.0	5.60	0.79	0.99	1.00
	2945	31.6	3.93	0.81	0.99	1.00	29.6	4.44	0.83	1.00	1.00	27.6	5.00	0.85	1.00	1.00	25.6	5.64	0.87	1.00	1.00
19.4°C	1965	30.7	3.91	0.56	0.68	0.81	28.7	4.42	0.55	0.69	0.83	26.6	4.98	0.54	0.69	0.84	24.4	5.61	0.54	0.70	0.87
	2455	32.4	3.95	0.59	0.74	0.90	30.3	4.45	0.59	0.75	0.92	28.1	5.01	0.59	0.76	0.94	25.9	5.64	0.59	0.77	0.96
	2945	33.8	3.98	0.62	0.79	0.97	31.5	4.48	0.62	0.81	0.99	29.2	5.04	0.63	0.82	0.99	26.9	5.67	0.63	0.85	1.00
21.7°C	1965	32.7	3.95	0.42	0.55	0.66	30.6	4.46	0.41	0.54	0.67	28.5	5.02	0.39	0.54	0.67	26.3	5.65	0.37	0.53	0.68
	2455	34.6	3.99	0.44	0.58	0.72	32.4	4.50	0.42	0.58	0.73	30.1	5.06	0.41	0.58	0.74	27.9	5.69	0.40	0.58	0.75
	2945	35.9	4.03	0.45	0.62	0.77	33.7	4.53	0.44	0.62	0.78	31.3	5.09	0.43	0.62	0.80	28.9	5.72	0.42	0.63	0.82

45.7 kW - LCH156H4 (2ND STAGE)

Entering Wet Bulb Temperature	Total Air Volume	Outdoor Air Temperature Entering Outdoor Coil																			
		26.7°C					35°C					43.3°C					46°C				
		Total Cool Cap.	Comp. Motor Input	Sensible To Total Ratio (S/T)			Total Cool Cap.	Comp. Motor Input	Sensible To Total Ratio (S/T)			Total Cool Cap.	Comp. Motor Input	Sensible To Total Ratio (S/T)			Total Cool Cap.	Comp. Motor Input	Sensible To Total Ratio (S/T)		
				Dry Bulb					Dry Bulb					Dry Bulb					Dry Bulb		
L/s	kW	kW	24°C	27°C	29°C	kW	kW	24°C	27°C	29°C	kW	kW	24°C	27°C	29°C	kW	kW	24°C	27°C	29°C	
17.2°C	1965	39.3	7.04	0.74	0.91	1.00	34.6	8.43	0.76	0.95	1.00	29.7	10.11	0.78	0.99	1.00	28.2	10.73	.79	.99	1.00
	2455	41.6	7.09	0.81	0.99	1.00	37.1	8.48	0.83	1.00	1.00	32.4	10.18	0.87	1.00	1.00	30.9	10.79	.89	1.00	1.00
	2945	44.0	7.15	0.87	1.00	1.00	39.4	8.54	0.91	1.00	1.00	34.6	10.24	0.96	1.00	1.00	33.0	10.85	.97	1.00	1.00
19.4°C	1965	42.3	7.11	0.57	0.72	0.87	37.5	8.49	0.56	0.74	0.91	32.3	10.18	0.56	0.75	0.95	30.7	10.79	.55	.77	.97
	2455	44.6	7.16	0.61	0.79	0.96	39.5	8.54	0.61	0.81	0.99	34.1	10.23	0.61	0.85	1.00	32.4	10.83	.62	.87	1.00
	2945	46.2	7.2	0.65	0.85	1.00	40.9	8.58	0.66	0.89	1.00	35.4	10.26	0.67	0.93	1.00	33.6	10.87	.68	.95	1.00
21.7°C	1965	45.3	7.17	0.41	0.56	0.70	40.3	8.56	0.39	0.56	0.71	35.1	10.25	0.37	0.55	0.73	33.4	10.86	.35	.55	.75
	2455	47.7	7.23	0.43	0.60	0.77	42.5	8.62	0.41	0.61	0.79	37.0	10.30	0.39	0.61	0.82	35.2	10.91	.38	.62	.84
	2945	49.5	7.28	0.45	0.64	0.83	44.0	8.66	0.43	0.65	0.86	38.3	10.34	0.42	0.67	0.91	36.5	10.95	.41	.68	.93

Entering Wet Bulb Temperature	Total Air Volume	Outdoor Air Temperature Entering Outdoor Coil														
		48°C					50°C					51.7°C				
		Total Cool Cap.	Comp. Motor Input	Sensible To Total Ratio (S/T)			Total Cool Cap.	Comp. Motor Input	Sensible To Total Ratio (S/T)			Total Cool Cap.	Comp. Motor Input	Sensible To Total Ratio (S/T)		
				Dry Bulb					Dry Bulb					Dry Bulb		
L/s	kW	kW	24°C	27°C	29°C	kW	kW	24°C	27°C	29°C	kW	kW	24°C	27°C	29°C	
17.2°C	1965	27.0	11.23	0.79	1.00	1.00	25.9	11.74	0.81	1.00	1.00	25.0	12.20	0.81	1.00	1.00
	2455	29.7	11.30	0.90	1.00	1.00	28.5	11.81	0.92	1.00	1.00	27.5	12.27	0.93	1.00	1.00
	2945	31.8	11.35	0.98	1.00	1.00	30.5	11.87	0.99	1.00	1.00	29.5	12.32	1.00	1.00	1.00
19.4°C	1965	29.4	11.29	0.55	0.77	0.98	28.1	11.80	0.55	0.78	0.99	27.0	12.25	0.55	0.79	0.99
	2455	31.0	11.33	0.62	0.87	1.00	29.7	11.84	0.62	0.89	1.00	28.5	12.30	0.62	0.90	1.00
	2945	32.2	11.37	0.68	0.96	1.00	30.9	11.88	0.68	0.98	1.00	29.7	12.33	0.69	0.99	1.00
21.7°C	1965	32.0	11.36	0.34	0.55	0.75	30.7	11.87	0.33	0.55	0.76	29.6	12.32	0.32	0.55	0.76
	2455	33.8	11.41	0.38	0.62	0.85	32.4	11.92	0.37	0.62	0.86	31.2	12.37	0.36	0.62	0.87
	2945	35.0	11.45	0.41	0.68	0.94	33.6	11.96	0.40	0.69	0.95	32.4	12.41	0.40	0.69	0.96

RATINGS

NOTE – For Temperatures and Capacities not shown in tables, see bulletin – Cooling Unit Rating Table Correction Factor Data in Miscellaneous Engineering Data section.

52.8 kW - LCH180H4 (1ST STAGE)

Entering Wet Bulb Temperature	Total Air Volume	Outdoor Air Temperature Entering Outdoor Coil																			
		18.3°C					23.9°C					29.4°C					35°C				
		Total Cool Cap.	Comp. Motor Input	Sensible To Total Ratio (S/T)			Total Cool Cap.	Comp. Motor Input	Sensible To Total Ratio (S/T)			Total Cool Cap.	Comp. Motor Input	Sensible To Total Ratio (S/T)			Total Cool Cap.	Comp. Motor Input	Sensible To Total Ratio (S/T)		
				Dry Bulb					Dry Bulb					Dry Bulb					Dry Bulb		
L/s	kW	kW	24°C	27°C	29°C	kW	kW	24°C	27°C	29°C	kW	kW	24°C	27°C	29°C	kW	kW	24°C	27°C	29°C	
17.2°C	2265	33.1	4.13	0.73	0.86	0.98	31.1	4.77	0.73	0.87	0.99	28.9	5.46	0.74	0.89	1.00	26.7	6.22	0.75	0.90	1.00
	2830	35.1	4.14	0.78	0.93	1.00	32.9	4.78	0.79	0.94	1.00	30.6	5.48	0.80	0.96	1.00	28.3	6.25	0.81	0.98	1.00
	3400	36.5	4.14	0.83	0.98	1.00	34.3	4.79	0.84	1.00	1.00	32.1	5.49	0.85	1.00	1.00	29.9	6.26	0.87	1.00	1.00
19.4°C	2265	35.5	4.14	0.58	0.71	0.83	33.3	4.78	0.57	0.71	0.84	31.1	5.48	0.57	0.71	0.85	28.8	6.25	0.56	0.72	0.87
	2830	37.5	4.14	0.61	0.76	0.90	35.3	4.79	0.61	0.77	0.91	32.9	5.50	0.61	0.78	0.93	30.5	6.27	0.61	0.79	0.95
	3400	39.0	4.14	0.64	0.81	0.95	36.7	4.80	0.65	0.82	0.97	34.2	5.51	0.65	0.83	0.99	31.7	6.29	0.65	0.85	1.00
21.7°C	2265	37.7	4.14	0.44	0.57	0.69	35.5	4.79	0.43	0.56	0.69	33.3	5.50	0.41	0.56	0.69	30.9	6.28	0.40	0.55	0.70
	2830	39.9	4.15	0.45	0.60	0.74	37.6	4.81	0.44	0.60	0.75	35.1	5.52	0.43	0.60	0.76	32.6	6.30	0.42	0.60	0.77
	3400	41.4	4.15	0.46	0.63	0.79	39.0	4.81	0.45	0.64	0.80	36.5	5.53	0.45	0.64	0.81	33.9	6.31	0.44	0.64	0.83

52.8 kW - LCH180H4 (2ND STAGE)

Entering Wet Bulb Temperature	Total Air Volume	Outdoor Air Temperature Entering Outdoor Coil																			
		26.7°C					35°C					43.3°C					46°C				
		Total Cool Cap.	Comp. Motor Input	Sensible To Total Ratio (S/T)			Total Cool Cap.	Comp. Motor Input	Sensible To Total Ratio (S/T)			Total Cool Cap.	Comp. Motor Input	Sensible To Total Ratio (S/T)			Total Cool Cap.	Comp. Motor Input	Sensible To Total Ratio (S/T)		
				Dry Bulb					Dry Bulb					Dry Bulb					Dry Bulb		
L/s	kW	kW	24°C	27°C	29°C	kW	kW	24°C	27°C	29°C	kW	kW	24°C	27°C	29°C	kW	kW	24°C	27°C	29°C	
17.2°C	2265	45.7	7.68	0.75	0.91	1.00	40.6	9.36	0.76	0.94	1.00	35.2	11.30	0.78	0.98	1.00	33.4	11.99	.79	.99	1.00
	2830	48.3	7.7	0.81	0.99	1.00	43.2	9.39	0.83	1.00	1.00	38.1	11.36	0.87	1.00	1.00	36.3	12.05	.89	1.00	1.00
	3400	50.8	7.72	0.87	1.00	1.00	45.8	9.43	0.90	1.00	1.00	40.4	11.41	0.95	1.00	1.00	38.6	12.10	.97	1.00	1.00
19.4°C	2265	49.1	7.71	0.57	0.73	0.87	43.9	9.40	0.57	0.74	0.91	38.1	11.36	0.57	0.76	0.95	36.2	12.04	.57	.77	.96
	2830	51.7	7.73	0.62	0.79	0.96	46.1	9.43	0.62	0.81	0.99	40.1	11.40	0.62	0.85	1.00	38.0	12.09	.63	.86	1.00
	3400	53.5	7.74	0.65	0.85	1.00	47.7	9.45	0.66	0.88	1.00	41.4	11.43	0.67	0.93	1.00	39.4	12.12	.68	.95	1.00
21.7°C	2265	52.4	7.73	0.42	0.56	0.70	47.0	9.44	0.40	0.56	0.72	41.1	11.42	0.38	0.56	0.74	39.1	12.11	.37	.57	.75
	2830	55.1	7.75	0.43	0.61	0.77	49.4	9.48	0.42	0.61	0.79	43.2	11.46	0.40	0.62	0.82	41.1	12.15	.40	.62	.84
	3400	57.0	7.77	0.45	0.65	0.83	51.0	9.50	0.44	0.66	0.86	44.6	11.49	0.43	0.68	0.91	42.4	12.18	.43	.68	.92

Entering Wet Bulb Temperature	Total Air Volume	Outdoor Air Temperature Entering Outdoor Coil																	
		48°C					50°C					51.7°C							
		Total Cool Cap.	Comp. Motor Input	Sensible To Total Ratio (S/T)			Total Cool Cap.	Comp. Motor Input	Sensible To Total Ratio (S/T)			Total Cool Cap.	Comp. Motor Input	Sensible To Total Ratio (S/T)					
				Dry Bulb					Dry Bulb					Dry Bulb					
L/s	kW	kW	24°C	27°C	29°C	kW	kW	24°C	27°C	29°C	kW	kW	24°C	27°C	29°C				
17.2°C	2265	32.1	12.53	0.80	1.00	1.00	30.7	13.09	0.81	1.00	1.00	29.6	13.58	0.82	1.00	1.00			
	2830	35.0	12.60	0.90	1.00	1.00	33.6	13.17	0.91	1.00	1.00	32.3	13.65	0.93	1.00	1.00			
	3400	37.1	12.65	0.98	1.00	1.00	35.7	13.21	0.99	1.00	1.00	34.4	13.70	1.00	1.00	1.00			
19.4°C	2265	34.7	12.60	0.57	0.78	0.98	33.1	13.15	0.57	0.79	0.99	31.9	13.64	0.57	0.80	1.00			
	2830	36.4	12.64	0.63	0.88	1.00	34.8	13.19	0.63	0.89	1.00	33.4	13.68	0.64	0.90	1.00			
	3400	37.7	12.67	0.69	0.96	1.00	36.1	13.23	0.69	0.98	1.00	34.7	13.72	0.70	0.99	1.00			
21.7°C	2265	37.6	12.66	0.36	0.57	0.76	35.9	13.22	0.35	0.57	0.77	34.6	13.71	0.34	0.57	0.78			
	2830	39.5	12.71	0.39	0.63	0.85	37.7	13.27	0.39	0.63	0.87	36.3	13.76	0.38	0.64	0.88			
	3400	40.7	12.74	0.42	0.69	0.94	38.9	13.30	0.42	0.70	0.95	37.5	13.79	0.42	0.71	0.97			

RATINGS

NOTE – For Temperatures and Capacities not shown in tables, see bulletin – Cooling Unit Rating Table Correction Factor Data in Miscellaneous Engineering Data section.

61.5 kW - LCH210H4 (1ST STAGE)

Entering Wet Bulb Temperature	Total Air Volume	Outdoor Air Temperature Entering Outdoor Coil																			
		18.3°C					23.9°C					29.4°C					35°C				
		Total Cool Cap.	Comp. Motor Input	Sensible To Total Ratio (S/T)			Total Cool Cap.	Comp. Motor Input	Sensible To Total Ratio (S/T)			Total Cool Cap.	Comp. Motor Input	Sensible To Total Ratio (S/T)			Total Cool Cap.	Comp. Motor Input	Sensible To Total Ratio (S/T)		
				Dry Bulb					Dry Bulb					Dry Bulb					Dry Bulb		
L/s	kW	kW	24°C	27°C	29°C	kW	kW	24°C	27°C	29°C	kW	kW	24°C	27°C	29°C	kW	kW	24°C	27°C	29°C	
17.2°C	2645	36.8	4.54	0.75	0.90	1.00	34.5	5.17	0.76	0.92	1.00	32.0	5.85	0.77	0.94	1.00	29.5	6.61	0.79	0.97	1.00
	3305	38.9	4.58	0.81	0.98	1.00	36.4	5.21	0.83	1.00	1.00	34.1	5.90	0.84	1.00	1.00	31.8	6.66	0.86	1.00	1.00
	3965	40.9	4.63	0.87	1.00	1.00	38.6	5.26	0.89	1.00	1.00	36.1	5.95	0.91	1.00	1.00	33.6	6.72	0.94	1.00	1.00
19.4°C	2645	39.4	4.6	0.59	0.73	0.87	37.0	5.23	0.59	0.74	0.89	34.5	5.91	0.59	0.75	0.91	31.9	6.67	0.59	0.76	0.93
	3305	41.4	4.64	0.63	0.79	0.95	38.8	5.27	0.63	0.81	0.97	36.1	5.95	0.62	0.82	0.99	33.3	6.71	0.64	0.84	1.00
	3965	42.8	4.67	0.66	0.85	1.00	40.1	5.30	0.67	0.87	1.00	37.3	5.98	0.67	0.89	1.00	34.5	6.74	0.68	0.92	1.00
21.7°C	2645	42.3	4.66	0.44	0.58	0.71	39.7	5.29	0.43	0.58	0.72	37.0	5.98	0.42	0.58	0.73	34.3	6.74	0.41	0.58	0.74
	3305	44.2	4.71	0.46	0.62	0.77	41.5	5.34	0.45	0.62	0.79	38.7	6.02	0.44	0.62	0.80	35.8	6.78	0.43	0.63	0.82
	3965	45.6	4.74	0.47	0.65	0.83	42.8	5.37	0.44	0.66	0.85	39.8	6.06	0.47	0.67	0.87	36.8	6.81	0.45	0.68	0.89

61.5 kW - LCH210H4 (2ND STAGE)

Entering Wet Bulb Temperature	Total Air Volume	Outdoor Air Temperature Entering Outdoor Coil																			
		26.7°C					35°C					43.3°C					46°C				
		Total Cool Cap.	Comp. Motor Input	Sensible To Total Ratio (S/T)			Total Cool Cap.	Comp. Motor Input	Sensible To Total Ratio (S/T)			Total Cool Cap.	Comp. Motor Input	Sensible To Total Ratio (S/T)			Total Cool Cap.	Comp. Motor Input	Sensible To Total Ratio (S/T)		
				Dry Bulb					Dry Bulb					Dry Bulb					Dry Bulb		
L/s	kW	kW	24°C	27°C	29°C	kW	kW	24°C	27°C	29°C	kW	kW	24°C	27°C	29°C	kW	kW	24°C	27°C	29°C	
17.2°C	2645	52.3	8.76	0.76	0.92	1.00	46.7	10.53	0.77	0.95	1.00	40.8	12.65	0.80	0.99	1.00	38.9	13.41	.81	.99	1.00
	3305	55.5	8.83	0.82	0.99	1.00	49.9	10.61	0.85	1.00	1.00	44.2	12.74	0.89	1.00	1.00	42.3	13.50	.91	1.00	1.00
	3965	58.6	8.91	0.88	1.00	1.00	52.9	10.69	0.92	1.00	1.00	46.9	12.81	0.97	1.00	1.00	44.8	13.57	.98	1.00	1.00
19.4°C	2645	56.3	8.85	0.58	0.73	0.88	50.3	10.62	0.58	0.75	0.92	43.9	12.73	0.58	0.77	0.96	41.9	13.49	.59	.79	.98
	3305	59.1	8.92	0.62	0.80	0.97	52.7	10.68	0.63	0.82	0.99	46.1	12.79	0.64	0.86	1.00	44.0	13.54	.64	.89	1.00
	3965	61.1	8.97	0.65	0.87	1.00	54.5	10.73	0.67	0.90	1.00	47.8	12.84	0.69	0.95	1.00	45.4	13.59	.70	.96	1.00
21.7°C	2645	60.4	8.95	0.42	0.57	0.71	54.2	10.72	0.41	0.57	0.73	47.5	12.83	0.39	0.57	0.75	45.3	13.58	.38	.58	.77
	3305	63.2	9.02	0.44	0.61	0.78	56.6	10.79	0.43	0.62	0.81	49.6	12.89	0.41	0.63	0.84	47.4	13.64	.41	.64	.86
	3965	65.1	9.07	0.46	0.65	0.85	58.4	10.84	0.44	0.67	0.88	51.3	12.94	0.45	0.69	0.93	48.9	13.69	.44	.70	.95

Entering Wet Bulb Temperature	Total Air Volume	Outdoor Air Temperature Entering Outdoor Coil																	
		48°C					50°C					51.7°C							
		Total Cool Cap.	Comp. Motor Input	Sensible To Total Ratio (S/T)			Total Cool Cap.	Comp. Motor Input	Sensible To Total Ratio (S/T)			Total Cool Cap.	Comp. Motor Input	Sensible To Total Ratio (S/T)					
				Dry Bulb					Dry Bulb					Dry Bulb					
L/s	kW	kW	24°C	27°C	29°C	kW	kW	24°C	27°C	29°C	kW	kW	24°C	27°C	29°C				
17.2°C	2645	37.5	14.03	0.82	1.00	1.00	36.0	14.66	0.83	1.00	1.00	34.8	15.21	0.84	1.00	1.00			
	3305	40.7	14.11	0.92	1.00	1.00	39.2	14.73	0.94	1.00	1.00	38.0	15.29	0.95	1.00	1.00			
	3965	43.2	14.18	0.99	1.00	1.00	41.6	14.80	0.99	1.00	1.00	40.2	15.35	0.99	1.00	1.00			
19.4°C	2645	40.2	14.10	0.58	0.79	0.98	38.4	14.72	0.58	0.81	0.99	37.0	15.26	0.58	0.82	0.99			
	3305	42.1	14.15	0.64	0.90	1.00	40.4	14.77	0.65	0.91	1.00	39.0	15.32	0.65	0.93	1.00			
	3965	43.7	14.19	0.71	0.98	1.00	42.0	14.81	0.72	0.98	1.00	40.5	15.36	0.73	0.99	1.00			
21.7°C	2645	43.6	14.19	0.38	0.58	0.77	41.9	14.81	0.37	0.58	0.78	40.3	15.34	0.37	0.58	0.79			
	3305	45.5	14.25	0.41	0.64	0.87	43.7	14.86	0.41	0.65	0.89	42.2	15.40	0.40	0.66	0.90			
	3965	47.0	14.28	0.45	0.71	0.96	45.1	14.90	0.44	0.72	0.97	43.5	15.45	0.44	0.73	0.98			

RATINGS

NOTE – For Temperatures and Capacities not shown in tables, see bulletin – Cooling Unit Rating Table Correction Factor Data in Miscellaneous Engineering Data section.

70.3 kW - LCH240H4 (1ST STAGE)

Entering Wet Bulb Temperature	Total Air Volume	Outdoor Air Temperature Entering Outdoor Coil																			
		18.3°C					23.9°C					29.4°C					35°C				
		Total Cool Cap.	Comp. Motor Input	Sensible To Total Ratio (S/T)			Total Cool Cap.	Comp. Motor Input	Sensible To Total Ratio (S/T)			Total Cool Cap.	Comp. Motor Input	Sensible To Total Ratio (S/T)			Total Cool Cap.	Comp. Motor Input	Sensible To Total Ratio (S/T)		
				Dry Bulb					Dry Bulb					Dry Bulb					Dry Bulb		
L/s	kW	kW	24°C	27°C	29°C	kW	kW	24°C	27°C	29°C	kW	kW	24°C	27°C	29°C	kW	kW	24°C	27°C	29°C	
17.2°C	3020	33.6	4.26	0.72	0.86	0.99	31.7	4.85	0.73	0.88	1.00	29.9	5.50	0.74	0.90	1.00	27.9	6.23	0.75	0.93	1.00
	3775	35.4	4.3	0.77	0.94	1.00	33.5	4.90	0.79	0.97	1.00	31.6	5.55	0.80	0.98	1.00	29.6	6.27	0.82	0.99	1.00
	4530	37.0	4.34	0.83	0.99	1.00	35.0	4.94	0.85	1.00	1.00	33.1	5.59	0.86	1.00	1.00	31.2	6.32	0.90	1.00	1.00
19.4°C	3020	35.9	4.31	0.57	0.70	0.83	34.0	4.91	0.57	0.70	0.84	32.0	5.56	0.57	0.72	0.86	29.9	6.28	0.57	0.73	0.89
	3775	37.6	4.35	0.60	0.75	0.91	35.5	4.95	0.61	0.77	0.93	33.4	5.60	0.61	0.78	0.96	31.2	6.32	0.61	0.80	0.98
	4530	38.9	4.39	0.64	0.81	0.98	36.7	4.98	0.63	0.82	0.99	34.5	5.63	0.65	0.84	1.00	32.2	6.36	0.66	0.87	1.00
21.7°C	3020	38.2	4.37	0.43	0.55	0.67	36.3	4.97	0.42	0.56	0.68	34.1	5.62	0.42	0.56	0.70	31.9	6.35	0.41	0.56	0.71
	3775	40.0	4.42	0.44	0.59	0.73	37.9	5.02	0.44	0.60	0.75	35.7	5.67	0.44	0.61	0.76	33.3	6.39	0.43	0.61	0.78
	4530	41.3	4.45	0.46	0.63	0.79	39.0	5.05	0.46	0.63	0.80	36.7	5.70	0.45	0.64	0.82	34.2	6.42	0.46	0.65	0.85

70.3 kW - LCH240H4 (2ND STAGE)

Entering Wet Bulb Temperature	Total Air Volume	Outdoor Air Temperature Entering Outdoor Coil																			
		26.7°C					35°C					43.3°C					46°C				
		Total Cool Cap.	Comp. Motor Input	Sensible To Total Ratio (S/T)			Total Cool Cap.	Comp. Motor Input	Sensible To Total Ratio (S/T)			Total Cool Cap.	Comp. Motor Input	Sensible To Total Ratio (S/T)			Total Cool Cap.	Comp. Motor Input	Sensible To Total Ratio (S/T)		
				Dry Bulb					Dry Bulb					Dry Bulb					Dry Bulb		
L/s	kW	kW	24°C	27°C	29°C	kW	kW	24°C	27°C	29°C	kW	kW	24°C	27°C	29°C	kW	kW	24°C	27°C	29°C	
17.2°C	3020	62.5	10.37	0.77	0.94	1.00	56.6	12.48	0.79	0.97	1.00	50.5	15.05	0.82	0.99	1.00	48.4	15.98	.85	1.00	1.00
	3775	66.0	10.47	0.83	1.00	1.00	60.1	12.59	0.87	1.00	1.00	53.9	15.17	0.92	1.00	1.00	51.8	16.10	.94	1.00	1.00
	4530	69.3	10.57	0.90	1.00	1.00	63.2	12.69	0.94	1.00	1.00	56.5	15.26	0.98	1.00	1.00	54.4	16.19	.99	1.00	1.00
19.4°C	3020	66.6	10.48	0.59	0.74	0.90	60.2	12.59	0.60	0.77	0.94	53.3	15.15	0.61	0.80	0.98	51.0	16.07	.62	.83	.99
	3775	69.4	10.57	0.63	0.81	0.98	62.7	12.67	0.64	0.84	1.00	55.5	15.23	0.66	0.89	1.00	53.1	16.14	.68	.92	1.00
	4530	71.5	10.64	0.67	0.88	1.00	64.5	12.74	0.69	0.92	1.00	57.3	15.29	0.71	0.97	1.00	54.7	16.20	.74	.98	1.00
21.7°C	3020	71.0	10.62	0.43	0.58	0.72	64.4	12.73	0.42	0.59	0.75	57.1	15.28	0.41	0.60	0.78	54.7	16.20	.42	.61	.81
	3775	73.8	10.71	0.45	0.63	0.79	66.7	12.81	0.45	0.64	0.82	59.1	15.36	0.44	0.66	0.87	56.6	16.27	.44	.67	.90
	4530	75.7	10.77	0.47	0.66	0.86	68.4	12.87	0.47	0.69	0.90	60.6	15.41	0.47	0.71	0.96	58.0	16.33	.48	.74	.97

Entering Wet Bulb Temperature	Total Air Volume	Outdoor Air Temperature Entering Outdoor Coil																	
		48°C					50°C					51.7°C							
		Total Cool Cap.	Comp. Motor Input	Sensible To Total Ratio (S/T)			Total Cool Cap.	Comp. Motor Input	Sensible To Total Ratio (S/T)			Total Cool Cap.	Comp. Motor Input	Sensible To Total Ratio (S/T)					
				Dry Bulb					Dry Bulb					Dry Bulb					
L/s	kW	kW	24°C	27°C	29°C	kW	kW	24°C	27°C	29°C	kW	kW	24°C	27°C	29°C				
17.2°C	3020	46.9	16.74	0.84	1.00	1.00	45.3	17.52	0.86	1.00	1.00	44.0	18.21	0.88	1.00	1.00			
	3775	50.2	16.85	0.95	1.00	1.00	48.5	17.62	0.96	1.00	1.00	47.1	18.31	0.97	1.00	1.00			
	4530	52.7	16.94	1.00	1.00	1.00	50.9	17.72	1.00	1.00	1.00	49.4	18.39	1.00	1.00	1.00			
19.4°C	3020	49.1	16.82	0.61	0.82	0.99	47.4	17.59	0.62	0.84	1.00	45.9	18.27	0.62	0.85	1.00			
	3775	51.3	16.90	0.67	0.93	1.00	49.4	17.66	0.68	0.94	1.00	47.7	18.34	0.69	0.96	1.00			
	4530	53.0	16.95	0.74	0.99	1.00	51.1	17.72	0.75	0.99	1.00	49.5	18.41	0.76	1.00	1.00			
21.7°C	3020	52.8	16.94	0.41	0.61	0.80	50.8	17.71	0.41	0.61	0.81	49.2	18.39	0.41	0.62	0.83			
	3775	54.6	17.01	0.44	0.67	0.90	52.6	17.77	0.44	0.68	0.92	50.9	18.45	0.44	0.69	0.94			
	4530	56.0	17.07	0.47	0.74	0.98	53.9	17.83	0.47	0.75	0.99	52.2	18.50	0.47	0.76	0.99			

RATINGS

NOTE – For Temperatures and Capacities not shown in tables, see bulletin – Cooling Unit Rating Table Correction Factor Data in Miscellaneous Engineering Data section.

88 kW - LCH300S4 (1ST STAGE)

Entering Wet Bulb Temperature	Total Air Volume	Outdoor Air Temperature Entering Outdoor Coil																			
		18.3°C					23.9°C					29.4°C					35°C				
		Total Cool Cap.	Comp. Motor Input	Sensible To Total Ratio (S/T)			Total Cool Cap.	Comp. Motor Input	Sensible To Total Ratio (S/T)			Total Cool Cap.	Comp. Motor Input	Sensible To Total Ratio (S/T)			Total Cool Cap.	Comp. Motor Input	Sensible To Total Ratio (S/T)		
				Dry Bulb					Dry Bulb					Dry Bulb					Dry Bulb		
L/s	kW	kW	24°C	27°C	29°C	kW	kW	24°C	27°C	29°C	kW	kW	24°C	27°C	29°C	kW	kW	24°C	27°C	29°C	
17.2°C	3775	38	5.26	0.72	0.87	0.99	36.3	5.94	0.74	0.9	1	34.7	6.71	0.75	0.92	1	33.3	7.59	0.78	0.95	1
	4485	39.4	5.3	0.76	0.93	1	37.6	5.99	0.79	0.96	1	35.9	6.76	0.8	0.98	1	34.4	7.64	0.82	0.99	1
	5190	40.5	5.34	0.81	0.98	1	38.6	6.03	0.83	0.99	1	37	6.8	0.85	1	1	35.5	7.68	0.87	1	1
19.4°C	3775	40.1	5.33	0.57	0.7	0.84	38.2	6.02	0.58	0.71	0.86	36.6	6.79	0.59	0.74	0.88	35	7.66	0.6	0.75	0.91
	4485	41.4	5.37	0.59	0.74	0.9	39.6	6.07	0.61	0.77	0.93	37.7	6.83	0.62	0.78	0.95	36	7.7	0.63	0.8	0.97
	5190	42.5	5.41	0.62	0.79	0.96	40.4	6.1	0.64	0.81	0.98	38.5	6.86	0.64	0.83	0.99	36.7	7.74	0.65	0.85	1
21.7°C	3775	42.5	5.41	0.43	0.56	0.68	40.5	6.1	0.43	0.57	0.69	38.6	6.87	0.45	0.58	0.72	36.9	7.75	0.44	0.59	0.73
	4485	43.7	5.46	0.44	0.58	0.72	41.7	6.15	0.44	0.6	0.74	39.8	6.92	0.45	0.61	0.76	37.9	7.8	0.45	0.62	0.78
	5190	44.7	5.5	0.44	0.61	0.76	42.6	6.19	0.44	0.63	0.78	40.5	6.95	0.45	0.63	0.8	38.6	7.83	0.47	0.65	0.83

88 kW - LCH300S4 (2ND STAGE)

Entering Wet Bulb Temperature	Total Air Volume	Outdoor Air Temperature Entering Outdoor Coil																			
		26.7°C					35°C					43.3°C					46°C				
		Total Cool Cap.	Comp. Motor Input	Sensible To Total Ratio (S/T)			Total Cool Cap.	Comp. Motor Input	Sensible To Total Ratio (S/T)			Total Cool Cap.	Comp. Motor Input	Sensible To Total Ratio (S/T)			Total Cool Cap.	Comp. Motor Input	Sensible To Total Ratio (S/T)		
				Dry Bulb					Dry Bulb					Dry Bulb					Dry Bulb		
L/s	kW	kW	24°C	27°C	29°C	kW	kW	24°C	27°C	29°C	kW	kW	24°C	27°C	29°C	kW	kW	24°C	27°C	29°C	
17.2°C	3775	73.2	14	0.76	0.92	1	68.2	16.58	0.78	0.96	1	63.1	19.77	0.81	0.99	1	61.5	20.96	.84	1.00	1.00
	4485	75.6	14.13	0.8	0.98	1	70.4	16.71	0.83	1	1	65.6	19.94	0.87	1	1	64.1	21.14	.90	1.00	1.00
	5190	77.8	14.25	0.85	1	1	72.9	16.86	0.88	1	1	67.8	20.08	0.93	1	1	66.3	21.29	.95	1.00	1.00
19.4°C	3775	77.2	14.22	0.59	0.73	0.88	71.8	16.8	0.61	0.76	0.92	66.4	19.98	0.62	0.79	0.97	64.6	21.17	.64	.82	.98
	4485	79.5	14.35	0.62	0.78	0.95	73.8	16.92	0.64	0.81	0.99	68.1	20.1	0.66	0.85	1	66.3	21.28	.67	.88	1.00
	5190	81.2	14.45	0.64	0.82	1	75.3	17.02	0.66	0.86	1	69.4	20.19	0.69	0.91	1	67.6	21.37	.71	.93	1.00
21.7°C	3775	81.5	14.46	0.44	0.58	0.71	75.8	17.05	0.44	0.6	0.74	70	20.23	0.45	0.62	0.77	68.1	21.41	.46	.63	.80
	4485	83.8	14.6	0.45	0.61	0.76	77.7	17.16	0.46	0.63	0.79	71.7	20.34	0.47	0.65	0.83	69.8	21.53	.48	.67	.85
	5190	85.5	14.69	0.46	0.64	0.8	79.2	17.26	0.47	0.65	0.84	73.1	20.43	0.48	0.68	0.88	71.0	21.61	.49	.71	.91

Entering Wet Bulb Temperature	Total Air Volume	Outdoor Air Temperature Entering Outdoor Coil																	
		48°C					50°C					51.7°C							
		Total Cool Cap.	Comp. Motor Input	Sensible To Total Ratio (S/T)			Total Cool Cap.	Comp. Motor Input	Sensible To Total Ratio (S/T)			Total Cool Cap.	Comp. Motor Input	Sensible To Total Ratio (S/T)					
				Dry Bulb					Dry Bulb					Dry Bulb					
L/s	kW	kW	24°C	27°C	29°C	kW	kW	24°C	27°C	29°C	kW	kW	24°C	27°C	29°C				
17.2°C	3775	60.2	21.98	.83	1.00	1.00	59.0	23.07	.84	1.00	1.00	58	24.1	0.85	1	1			
	4485	62.8	22.16	.90	1.00	1.00	61.6	23.26	.91	1.00	1.00	60.5	24.27	0.92	1	1			
	5190	64.9	22.29	.96	1.00	1.00	63.5	23.39	.97	1.00	1.00	62.4	24.4	0.98	1	1			
19.4°C	3775	63.2	22.18	.63	.81	.99	61.8	23.27	.64	.82	1.00	60.4	24.25	0.65	0.83	1			
	4485	64.9	22.29	.67	.87	1.00	63.3	23.37	.68	.88	1.00	62	24.38	0.68	0.9	1			
	5190	66.1	22.37	.70	.94	1.00	64.6	23.46	.71	.95	1.00	63.2	24.45	0.72	0.96	1			
21.7°C	3775	66.7	22.43	.46	.63	.79	65.1	23.50	.46	.63	.80	63.8	24.49	0.47	0.64	0.81			
	4485	68.2	22.52	.48	.66	.85	66.7	23.61	.48	.67	.86	65.4	24.61	0.48	0.68	0.88			
	5190	69.4	22.62	.49	.70	.92	67.8	23.69	.49	.70	.93	66.4	24.68	0.49	0.71	0.94			

HUMIDITROL® DEHUMIDIFICATION SYSTEM RATINGS

45.7 kW - LCH156H4 (1ST STAGE)

Entering Wet Bulb Temperature	Total Air Volume	Outdoor Air Temperature Entering Outdoor Coil																			
		18.3°C					23.9°C					29.4°C					35°C				
		Total Cool Cap.	Comp. Motor Input	Sensible To Total Ratio (S/T)			Total Cool Cap.	Comp. Motor Input	Sensible To Total Ratio (S/T)			Total Cool Cap.	Comp. Motor Input	Sensible To Total Ratio (S/T)			Total Cool Cap.	Comp. Motor Input	Sensible To Total Ratio (S/T)		
				Dry Bulb					Dry Bulb					Dry Bulb					Dry Bulb		
L/s	kW	kW	24°C	27°C	29°C	kW	kW	24°C	27°C	29°C	kW	kW	24°C	27°C	29°C	kW	kW	24°C	27°C	29°C	
17.2°C	1965	21.1	4.13	0.58	0.77	0.97	17.7	4.65	0.51	0.77	1.00	14.3	5.20	0.47	0.75	1.00	10.9	5.74	0.40	0.75	1.00
	2455	23.0	4.16	0.60	0.85	1.00	19.3	4.67	0.55	0.83	1.00	15.4	5.20	0.49	0.83	1.00	11.7	5.72	0.43	0.81	1.00
	2945	25.3	4.18	0.63	0.91	1.00	21.0	4.69	0.57	0.89	1.00	16.7	5.20	0.51	0.86	1.00	12.5	5.72	0.46	0.86	1.00
19.4°C	1965	24.0	4.21	0.41	0.59	0.77	20.6	4.75	0.34	0.55	0.78	17.3	5.28	0.27	0.50	0.77	14.0	5.81	0.18	0.48	0.77
	2945	26.1	4.21	0.42	0.64	0.85	22.3	4.75	0.35	0.59	0.85	18.5	5.28	0.27	0.56	0.86	14.8	5.81	0.19	0.52	0.86
	2945	28.1	4.22	0.44	0.67	0.91	23.9	4.75	0.36	0.63	0.93	19.7	5.28	0.27	0.60	0.93	15.7	5.80	0.18	0.56	0.93
21.7°C	1965	26.8	4.29	0.25	0.42	0.57	23.6	4.83	0.16	0.34	0.53	20.4	5.36	0.07	0.28	0.48	17.2	5.92	-0.03	0.21	0.45
	2455	28.9	4.28	0.26	0.42	0.61	25.3	4.81	0.15	0.36	0.57	21.6	5.37	0.05	0.30	0.55	17.9	5.89	-0.06	0.23	0.51
	2945	31.0	4.27	0.26	0.45	0.64	26.9	4.81	0.14	0.38	0.62	22.9	5.34	0.03	0.32	0.60	18.9	5.89	-0.09	0.24	0.58

45.7 kW - LCH156H4 (2ND STAGE)

Entering Wet Bulb Temperature	Total Air Volume	Outdoor Air Temperature Entering Outdoor Coil																			
		18.3°C					23.9°C					29.4°C					35°C				
		Total Cool Cap.	Comp. Motor Input	Sensible To Total Ratio (S/T)			Total Cool Cap.	Comp. Motor Input	Sensible To Total Ratio (S/T)			Total Cool Cap.	Comp. Motor Input	Sensible To Total Ratio (S/T)			Total Cool Cap.	Comp. Motor Input	Sensible To Total Ratio (S/T)		
				Dry Bulb					Dry Bulb					Dry Bulb					Dry Bulb		
L/s	kW	kW	24°C	27°C	29°C	kW	kW	24°C	27°C	29°C	kW	kW	24°C	27°C	29°C	kW	kW	24°C	27°C	29°C	
17.2°C	1965	35.0	6.30	0.66	0.85	1.00	31.0	7.15	0.64	0.87	1.00	27.1	8.02	0.63	0.89	1.00	23.1	8.87	0.59	0.89	1.00
	2455	38.0	6.32	0.70	0.92	1.00	33.5	7.19	0.70	0.94	1.00	29.1	8.04	0.68	0.95	1.00	24.7	8.91	0.66	0.95	1.00
	2945	41.0	6.35	0.75	0.96	1.00	36.1	7.22	0.75	0.99	1.00	31.3	8.08	0.75	1.00	1.00	26.4	8.94	0.76	1.00	1.00
19.4°C	1965	39.7	6.39	0.48	0.66	0.82	35.5	7.24	0.46	0.65	0.85	31.3	8.10	0.42	0.64	0.87	27.1	8.96	0.38	0.64	0.88
	2945	42.8	6.44	0.51	0.70	0.90	38.1	7.28	0.48	0.70	0.92	33.4	8.14	0.45	0.70	0.93	28.6	8.99	0.42	0.68	0.96
	2945	45.8	6.47	0.53	0.75	0.96	40.6	7.32	0.51	0.75	0.97	35.3	8.18	0.49	0.74	0.97	30.2	9.03	0.46	0.74	1.00
21.7°C	1965	44.2	6.49	0.31	0.47	0.61	39.8	7.36	0.27	0.43	0.60	35.5	8.20	0.23	0.40	0.60	31.2	9.04	0.17	0.37	0.59
	2455	47.6	6.53	0.31	0.49	0.66	42.6	7.40	0.28	0.46	0.65	37.7	8.24	0.23	0.43	0.65	32.6	9.09	0.17	0.40	0.65
	2945	50.9	6.59	0.33	0.51	0.70	45.3	7.44	0.28	0.49	0.71	39.7	8.29	0.23	0.46	0.71	34.3	9.12	0.17	0.44	0.72

52.8 kW - LCH180H4 (1ST STAGE)

Entering Wet Bulb Temperature	Total Air Volume	Outdoor Air Temperature Entering Outdoor Coil																			
		18.3°C					23.9°C					29.4°C					35°C				
		Total Cool Cap.	Comp. Motor Input	Sensible To Total Ratio (S/T)			Total Cool Cap.	Comp. Motor Input	Sensible To Total Ratio (S/T)			Total Cool Cap.	Comp. Motor Input	Sensible To Total Ratio (S/T)			Total Cool Cap.	Comp. Motor Input	Sensible To Total Ratio (S/T)		
				Dry Bulb					Dry Bulb					Dry Bulb					Dry Bulb		
L/s	kW	kW	24°C	27°C	29°C	kW	kW	24°C	27°C	29°C	kW	kW	24°C	27°C	29°C	kW	kW	24°C	27°C	29°C	
17.2°C	2265	24.5	4.75	0.58	0.77	0.95	21.1	5.34	0.52	0.77	0.97	17.6	5.90	0.47	0.74	0.98	14.1	6.49	0.43	0.74	1.00
	2830	26.0	4.78	0.62	0.85	1.00	22.0	5.33	0.58	0.86	1.00	18.0	5.89	0.56	0.86	1.00	14.1	6.45	0.52	0.86	1.00
	3400	27.5	4.82	0.65	0.92	1.00	23.0	5.34	0.64	0.93	1.00	18.6	5.88	0.62	0.99	1.00	14.2	6.41	0.60	1.00	1.00
19.4°C	2265	27.8	4.84	0.42	0.59	0.76	24.2	5.44	0.35	0.55	0.75	20.6	6.01	0.28	0.51	0.75	16.9	6.58	0.21	0.48	0.75
	3400	29.0	4.89	0.44	0.64	0.83	25.0	5.45	0.38	0.62	0.85	21.2	5.98	0.32	0.59	0.87	17.2	6.53	0.26	0.56	0.88
	3400	30.2	4.91	0.46	0.68	0.91	25.9	5.44	0.41	0.67	0.95	21.7	5.97	0.34	0.66	0.96	17.5	6.50	0.29	0.66	0.99
21.7°C	2265	31.1	4.96	0.25	0.40	0.55	27.3	5.52	0.17	0.34	0.52	23.5	6.11	0.09	0.29	0.47	19.8	6.69	0.01	0.23	0.45
	2830	32.0	4.97	0.25	0.42	0.59	28.1	5.53	0.17	0.37	0.57	24.2	6.09	0.08	0.32	0.54	20.5	6.65	0.00	0.26	0.53
	3400	32.9	5.00	0.25	0.45	0.64	28.9	5.55	0.17	0.40	0.63	25.0	6.06	0.08	0.35	0.61	21.1	6.60	-0.01	0.29	0.60

52.8 kW - LCH180H4 (2ND STAGE)

Entering Wet Bulb Temperature	Total Air Volume	Outdoor Air Temperature Entering Outdoor Coil																			
		18.3°C					23.9°C					29.4°C					35°C				
		Total Cool Cap.	Comp. Motor Input	Sensible To Total Ratio (S/T)			Total Cool Cap.	Comp. Motor Input	Sensible To Total Ratio (S/T)			Total Cool Cap.	Comp. Motor Input	Sensible To Total Ratio (S/T)			Total Cool Cap.	Comp. Motor Input	Sensible To Total Ratio (S/T)		
				Dry Bulb					Dry Bulb					Dry Bulb					Dry Bulb		
L/s	kW	kW	24°C	27°C	29°C	kW	kW	24°C	27°C	29°C	kW	kW	24°C	27°C	29°C	kW	kW	24°C	27°C	29°C	
17.2°C	2265	41.3	7.16	0.67	0.84	1.00	37.0	8.05	0.66	0.85	1.00	32.7	8.95	0.65	0.86	1.00	28.3	9.84	0.63	0.88	1.00
	2830	43.5	7.20	0.72	0.92	1.00	38.6	8.08	0.72	0.94	1.00	33.6	8.95	0.72	0.95	1.00	28.8	9.84	0.72	0.95	1.00
	3400	45.9	7.24	0.77	0.98	1.00	40.4	8.12	0.78	1.00	1.00	35.0	9.00	0.79	1.00	1.00	29.4	9.87	0.80	1.00	1.00
19.4°C	2265	45.8	7.29	0.50	0.64	0.80	41.5	8.19	0.46	0.64	0.83	37.1	9.08	0.43	0.64	0.84	32.6	9.98	0.40	0.63	0.86
	3400	48.1	7.33	0.51	0.69	0.85	43.1	8.21	0.50	0.68	0.89	38.2	9.10	0.48	0.70	0.91	33.2	9.97	0.46	0.70	0.95
	3400	50.3	7.36	0.56	0.70	0.86	44.8	8.23	0.53	0.72	0.92	39.2	9.09	0.51	0.75	0.95	33.7	9.95	0.49	0.77	1.00
21.7°C	2265	50.4	7.44	0.32	0.47	0.62	45.9	8.33	0.28	0.44	0.60	41.4	9.21	0.23	0.41	0.60	37.1	10.10	0.18	0.38	0.59
	2830	52.5	7.46	0.32	0.45	0.56	47.8	8.35	0.28	0.43	0.60	42.7	9.22	0.23	0.44	0.64	37.9	10.09	0.20	0.43	0.67
	3400	54.9	7.49	0.33	0.42	0.52	49.5	8.36	0.28	0.44	0.60	43.9	9.23	0.24	0.46	0.69	38.6	10.09	0.19	0.47	0.77

HUMIDITROL® DEHUMIDIFICATION SYSTEM RATINGS

61.5 kW - LCH210H4 (1ST STAGE)

Entering Wet Bulb Temperature	Total Air Volume	Outdoor Air Temperature Entering Outdoor Coil																							
		18.3°C						23.9°C						29.4°C						35°C					
		Total Cool Cap.	Comp. Motor Input	Sensible To Total Ratio (S/T)			Total Cool Cap.	Comp. Motor Input	Sensible To Total Ratio (S/T)			Total Cool Cap.	Comp. Motor Input	Sensible To Total Ratio (S/T)			Total Cool Cap.	Comp. Motor Input	Sensible To Total Ratio (S/T)						
				Dry Bulb					Dry Bulb					Dry Bulb					Dry Bulb						
L/s	kW	kW	24°C	27°C	29°C	kW	kW	24°C	27°C	29°C	kW	kW	24°C	27°C	29°C	kW	kW	24°C	27°C	29°C					
17.2°C	2645	28.2	5.08	0.60	0.81	0.99	24.3	5.70	0.54	0.78	1.00	20.5	6.31	0.50	0.77	1.00	16.6	6.92	0.45	0.76	1.00				
	3305	29.3	5.11	0.65	0.90	1.00	24.8	5.72	0.63	0.90	1.00	20.3	6.31	0.59	0.90	1.00	15.9	6.90	0.57	0.89	1.00				
	3965	30.4	5.14	0.71	0.95	1.00	25.5	5.73	0.70	1.00	1.00	20.3	6.32	0.68	1.00	1.00	15.0	6.91	0.67	1.00	1.00				
19.4°C	2645	32.1	5.22	0.44	0.61	0.81	28.2	5.83	0.36	0.57	0.80	24.1	6.41	0.30	0.54	0.78	20.2	7.02	0.24	0.51	0.77				
	3965	33.8	5.26	0.47	0.68	0.88	29.0	5.85	0.41	0.65	0.89	24.1	6.42	0.34	0.61	0.91	19.4	7.02	0.27	0.60	0.92				
	3965	35.2	5.29	0.49	0.73	0.94	29.7	5.86	0.43	0.71	0.96	24.1	6.43	0.39	0.70	1.00	18.7	7.01	0.33	0.70	1.00				
21.7°C	2645	36.3	5.36	0.26	0.43	0.60	32.0	5.96	0.18	0.37	0.55	27.9	6.54	0.10	0.31	0.52	23.7	7.12	0.02	0.24	0.47				
	3305	38.2	5.40	0.27	0.44	0.63	33.1	5.98	0.18	0.39	0.61	28.1	6.55	0.10	0.34	0.58	23.0	7.12	0.01	0.29	0.58				
	3965	39.9	5.43	0.28	0.45	0.65	34.2	6.00	0.18	0.41	0.65	28.3	6.57	0.09	0.37	0.68	22.4	7.12	0.00	0.34	0.69				

61.5 kW - LCH210H4 (2ND STAGE)

Entering Wet Bulb Temperature	Total Air Volume	Outdoor Air Temperature Entering Outdoor Coil																							
		18.3°C						23.9°C						29.4°C						35°C					
		Total Cool Cap.	Comp. Motor Input	Sensible To Total Ratio (S/T)			Total Cool Cap.	Comp. Motor Input	Sensible To Total Ratio (S/T)			Total Cool Cap.	Comp. Motor Input	Sensible To Total Ratio (S/T)			Total Cool Cap.	Comp. Motor Input	Sensible To Total Ratio (S/T)						
				Dry Bulb					Dry Bulb					Dry Bulb					Dry Bulb						
L/s	kW	kW	24°C	27°C	29°C	kW	kW	24°C	27°C	29°C	kW	kW	24°C	27°C	29°C	kW	kW	24°C	27°C	29°C					
17.2°C	2645	47.9	8.14	0.68	0.85	1.00	43.3	9.13	0.66	0.86	1.00	38.7	10.12	0.65	0.87	1.00	34.0	11.12	0.62	0.88	1.00				
	3305	50.6	8.22	0.72	0.92	1.00	45.6	9.20	0.72	0.93	1.00	40.4	10.20	0.70	0.93	1.00	35.4	11.17	0.69	0.94	1.00				
	3965	53.6	8.31	0.77	0.97	1.00	48.0	9.29	0.76	0.99	1.00	42.3	10.26	0.77	1.00	1.00	36.7	11.21	0.75	1.00	1.00				
19.4°C	2645	53.3	8.35	0.49	0.66	0.82	48.4	9.34	0.47	0.65	0.84	43.4	10.32	0.45	0.65	0.85	38.7	11.28	0.41	0.64	0.86				
	3965	56.1	8.46	0.53	0.71	0.89	50.6	9.43	0.50	0.71	0.92	45.2	10.37	0.47	0.70	0.93	39.7	11.33	0.45	0.69	0.93				
	3965	58.7	8.54	0.56	0.77	0.96	52.8	9.50	0.53	0.76	0.97	46.7	10.43	0.51	0.76	1.00	40.9	11.39	0.48	0.76	1.00				
21.7°C	2645	58.8	8.58	0.31	0.47	0.63	53.5	9.55	0.29	0.45	0.62	48.4	10.49	0.25	0.43	0.61	43.2	11.45	0.20	0.40	0.60				
	3305	61.5	8.68	0.33	0.51	0.69	55.8	9.63	0.29	0.48	0.68	50.1	10.57	0.26	0.46	0.68	44.4	11.50	0.21	0.43	0.67				
	3965	64.3	8.76	0.34	0.55	0.74	58.0	9.71	0.30	0.52	0.74	51.8	10.64	0.25	0.50	0.76	45.6	11.58	0.22	0.47	0.75				

70.3 kW - LCH240H4 (1ST STAGE)

Entering Wet Bulb Temperature	Total Air Volume	Outdoor Air Temperature Entering Outdoor Coil																							
		18.3°C						23.9°C						29.4°C						35°C					
		Total Cool Cap.	Comp. Motor Input	Sensible To Total Ratio (S/T)			Total Cool Cap.	Comp. Motor Input	Sensible To Total Ratio (S/T)			Total Cool Cap.	Comp. Motor Input	Sensible To Total Ratio (S/T)			Total Cool Cap.	Comp. Motor Input	Sensible To Total Ratio (S/T)						
				Dry Bulb					Dry Bulb					Dry Bulb					Dry Bulb						
L/s	kW	kW	24°C	27°C	29°C	kW	kW	24°C	27°C	29°C	kW	kW	24°C	27°C	29°C	kW	kW	24°C	27°C	29°C					
17.2°C	3020	24.4	4.72	0.54	0.74	0.92	20.2	5.28	0.44	0.71	0.96	16.0	5.85	0.35	0.69	1.00	11.9	6.42	0.26	0.68	1.00				
	3775	26.3	4.74	0.56	0.80	1.00	21.5	5.29	0.49	0.80	1.00	16.7	5.84	0.41	0.81	1.00	11.9	6.38	0.32	0.81	1.00				
	4530	28.4	4.76	0.59	0.85	1.00	22.9	5.30	0.53	0.88	1.00	17.4	5.83	0.45	0.92	1.00	12.0	6.35	0.38	0.97	1.00				
19.4°C	3020	28.5	4.84	0.38	0.54	0.71	23.9	5.40	0.27	0.49	0.73	19.4	5.96	0.18	0.44	0.72	14.8	6.53	0.07	0.40	0.72				
	4530	30.0	4.85	0.39	0.59	0.79	25.2	5.39	0.29	0.55	0.82	20.2	5.94	0.19	0.51	0.85	15.4	6.49	0.09	0.48	0.88				
	4530	31.6	4.88	0.41	0.64	0.87	26.3	5.40	0.32	0.61	0.92	21.1	5.93	0.20	0.59	0.96	15.9	6.46	0.11	0.57	0.99				
21.7°C	3020	32.6	4.97	0.23	0.36	0.51	27.6	5.52	0.10	0.29	0.46	22.8	6.07	-0.01	0.21	0.41	17.9	6.64	-0.12	0.12	0.38				
	3775	33.8	4.98	0.22	0.40	0.56	28.7	5.52	0.10	0.31	0.51	23.8	6.07	-0.02	0.23	0.48	18.9	6.61	-0.13	0.15	0.43				
	4530	35.1	4.98	0.21	0.42	0.61	30.0	5.52	0.09	0.34	0.57	24.9	6.05	-0.02	0.25	0.51	19.9	6.58	-0.14	0.15	0.47				

70.3 kW - LCH240H4 (2ND STAGE)

Entering Wet Bulb Temperature	Total Air Volume	Outdoor Air Temperature Entering Outdoor Coil																							
		18.3°C						23.9°C						29.4°C						35°C					
		Total Cool Cap.	Comp. Motor Input	Sensible To Total Ratio (S/T)			Total Cool Cap.	Comp. Motor Input	Sensible To Total Ratio (S/T)			Total Cool Cap.	Comp. Motor Input	Sensible To Total Ratio (S/T)			Total Cool Cap.	Comp. Motor Input	Sensible To Total Ratio (S/T)						
				Dry Bulb					Dry Bulb					Dry Bulb					Dry Bulb						
L/s	kW	kW	24°C	27°C	29°C	kW	kW	24°C	27°C	29°C	kW	kW	24°C	27°C	29°C	kW	kW	24°C	27°C	29°C					
17.2°C	3020	57.6	9.44	0.67	0.83	0.97	51.7	10.68	0.66	0.85	1.00	45.7	11.93	0.65	0.89	1.00	39.9	13.16	0.63	0.91	1.00				
	3775	60.4	9.48	0.72	0.91	1.00	53.8	10.68	0.73	0.92	1.00	47.2	11.91	0.74	0.94	1.00	40.6	13.14	0.74	0.97	1.00				
	4530	63.5	9.52	0.77	0.98	1.00	56.1	10.71	0.79	1.00	1.00	48.8	11.92	0.82	1.00	1.00	41.3	13.10	0.85	1.00	1.00				
19.4°C	3020	64.2	9.62	0.49	0.65	0.80	57.9	10.86	0.48	0.65	0.83	51.6	12.09	0.46	0.66	0.87	45.5	13.34	0.43	0.66	0.91				
	4530	66.3	9.63	0.54	0.70	0.89	59.7	10.86	0.51	0.72	0.92	53.0	12.10	0.50	0.72	0.93	46.6	13.32	0.47	0.71	0.94				
	4530	68.4	9.66	0.55	0.78	0.96	61.2	10.88	0.55	0.77	0.96	54.6	12.08	0.54	0.77	1.00	47.7	13.29	0.53	0.79	1.00				
21.7°C	3020	70.9	9.79	0.33	0.47	0.61	64.2	11.03	0.30	0.45	0.62	57.9	12.27	0.26	0.44	0.62	51.4	13.51	0.23	0.42	0.62				
	3775	72.3	9.80	0.34	0.52	0.68	65.8	11.05	0.30	0.49	0.69	59.2	12.26	0.27	0.47	0.69	52.8	13.49	0.22	0.45	0.69				
	4530	73.6	9.82	0.36	0.55	0.74	67.1	11.04	0.31	0.52	0.74	60.8	12.27	0.27	0.51	0.75	54.3	13.49	0.22	0.49	0.76				

HUMIDITROL® DEHUMIDIFICATION SYSTEM RATINGS

88 kW - LCH300S4 (1ST STAGE)

Entering Wet Bulb Temperature	Total Air Volume	Outdoor Air Temperature Entering Outdoor Coil																							
		18.3°C						23.9°C						29.4°C						35°C					
		Total Cool Cap.	Comp. Motor Input	Sensible To Total Ratio (S/T)			Total Cool Cap.	Comp. Motor Input	Sensible To Total Ratio (S/T)			Total Cool Cap.	Comp. Motor Input	Sensible To Total Ratio (S/T)			Total Cool Cap.	Comp. Motor Input	Sensible To Total Ratio (S/T)						
				Dry Bulb					Dry Bulb					Dry Bulb					Dry Bulb						
L/s	kW	kW	24°C	27°C	29°C	kW	kW	24°C	27°C	29°C	kW	kW	24°C	27°C	29°C	kW	kW	24°C	27°C	29°C					
17.2°C	3775	26.9	6.38	0.56	0.77	0.97	22.4	7.00	0.48	0.74	1.00	17.8	7.63	0.39	0.71	1.00	13.3	8.26	0.30	0.68	1.00				
	4485	28.5	6.45	0.60	0.80	0.99	23.9	7.06	0.52	0.79	1.00	19.3	7.66	0.43	0.77	1.00	14.8	8.28	0.35	0.76	1.00				
	5195	30.0	6.52	0.63	0.85	1.00	25.4	7.11	0.55	0.84	1.00	20.9	7.70	0.47	0.82	1.00	16.2	8.29	0.40	0.82	1.00				
19.4°C	3775	31.1	6.52	0.38	0.56	0.74	26.6	7.16	0.28	0.49	0.73	21.8	7.80	0.17	0.44	0.72	17.1	8.45	0.07	0.38	0.71				
	4485	32.8	6.57	0.40	0.58	0.77	27.9	7.20	0.30	0.52	0.77	22.9	7.84	0.19	0.48	0.78	17.9	8.47	0.08	0.44	0.79				
	5195	34.6	6.62	0.41	0.60	0.81	29.3	7.25	0.31	0.56	0.82	24.0	7.87	0.20	0.52	0.83	18.7	8.49	0.09	0.48	0.85				
21.7°C	3775	35.4	6.65	0.19	0.35	0.51	30.5	7.32	0.07	0.25	0.46	25.7	7.99	-0.04	0.17	0.40	21.0	8.65	-0.16	0.09	0.35				
	4485	37.2	6.69	0.19	0.35	0.53	31.9	7.35	0.07	0.27	0.48	26.6	8.01	-0.05	0.19	0.44	21.2	8.67	-0.17	0.11	0.40				
	5195	39.1	6.74	0.19	0.36	0.55	33.2	7.38	0.07	0.29	0.51	27.3	8.04	-0.07	0.21	0.49	21.4	8.70	-0.19	0.13	0.46				

88 kW - LCH300S4 (2ND STAGE)

Entering Wet Bulb Temperature	Total Air Volume	Outdoor Air Temperature Entering Outdoor Coil																							
		18.3°C						23.9°C						29.4°C						35°C					
		Total Cool Cap.	Comp. Motor Input	Sensible To Total Ratio (S/T)			Total Cool Cap.	Comp. Motor Input	Sensible To Total Ratio (S/T)			Total Cool Cap.	Comp. Motor Input	Sensible To Total Ratio (S/T)			Total Cool Cap.	Comp. Motor Input	Sensible To Total Ratio (S/T)						
				Dry Bulb					Dry Bulb					Dry Bulb					Dry Bulb						
L/s	kW	kW	24°C	27°C	29°C	kW	kW	24°C	27°C	29°C	kW	kW	24°C	27°C	29°C	kW	kW	24°C	27°C	29°C					
17.2°C	3775	68.3	12.69	0.68	0.86	1.00	62.0	14.12	0.67	0.88	1.00	55.6	15.55	0.67	0.90	1.00	49.3	16.96	0.66	0.91	1.00				
	4485	69.8	12.76	0.72	0.91	1.00	63.1	14.19	0.73	0.93	1.00	56.4	15.62	0.73	0.95	1.00	49.8	17.04	0.74	0.97	1.00				
	5195	71.5	12.84	0.76	0.95	1.00	64.3	14.26	0.78	0.97	1.00	57.3	15.71	0.79	0.98	1.00	50.3	17.13	0.82	0.99	1.00				
19.4°C	3775	72.5	12.91	0.49	0.67	0.85	67.0	14.38	0.49	0.67	0.86	61.3	15.86	0.47	0.67	0.87	55.6	17.31	0.44	0.66	0.89				
	4485	73.3	13.04	0.52	0.70	0.89	67.5	14.48	0.51	0.71	0.91	61.8	15.93	0.50	0.72	0.94	56.0	17.37	0.49	0.72	0.96				
	5195	74.0	13.17	0.54	0.73	0.92	68.1	14.59	0.54	0.75	0.96	62.2	16.01	0.54	0.78	0.98	56.4	17.43	0.52	0.79	0.99				
21.7°C	3775	76.8	13.12	0.33	0.48	0.63	71.9	14.63	0.29	0.47	0.63	67.2	16.17	0.26	0.44	0.62	62.2	17.70	0.23	0.41	0.62				
	4485	76.9	13.31	0.34	0.50	0.67	72.0	14.78	0.30	0.49	0.67	67.3	16.24	0.26	0.47	0.68	62.5	17.72	0.23	0.47	0.69				
	5195	76.8	13.50	0.34	0.52	0.70	72.1	14.92	0.31	0.52	0.72	67.5	16.33	0.27	0.51	0.75	62.9	17.74	0.24	0.50	0.77				

BLOWER DATA

BLOWER TABLE INCLUDES RESISTANCE FOR BASE UNIT ONLY WITH DRY INDOOR COIL & AIR FILTERS IN PLACE
FOR ALL UNITS ADD:

- 1 - Wet indoor coil air resistance of selected unit.
- 2 - Any factory installed options air resistance (electric heat, economizer, etc.)
- 3 - Any field installed accessories air resistance (electric heat, duct resistance, diffuser, etc.)

Then determine from blower table blower motor output and drive required.

See page 29 for wet coil and option/accessory air resistance data.

See page 29 for factory installed drive kit specifications.

MINIMUM AIR VOLUME REQUIRED FOR USE WITH OPTIONAL ELECTRIC HEAT

LCH156H units require 2455 L/s (5200 cfm) minimum air with electric heat.

All other units require 2830 L/s (6000 cfm) minimum air with electric heat.

Air Volume		TOTAL STATIC PRESSURE - Pa (Inches Water Gauge)																	
		100 (0.40)			150 (0.60)			200 (0.80)			250 (1.00)			300 (1.20)			350 (1.40)		
L/s	cfm	rev/min	kW	BHP	rev/min	kW	BHP	rev/min	kW	BHP	rev/min	kW	BHP	rev/min	kW	BHP	rev/min	kW	BHP
1890	4000	545	0.63	0.85	635	0.82	1.10	715	1.04	1.40	785	1.27	1.70	850	1.49	2.00	910	1.72	2.30
2005	4250	555	0.67	0.90	645	0.93	1.25	725	1.16	1.55	795	1.38	1.85	855	1.60	2.15	915	1.83	2.45
2125	4500	565	0.75	1.00	655	1.01	1.35	730	1.23	1.65	800	1.49	2.00	865	1.75	2.35	925	1.98	2.65
2240	4750	575	0.82	1.10	660	1.08	1.45	740	1.34	1.80	810	1.60	2.15	870	1.86	2.50	930	2.13	2.85
2360	5000	585	0.93	1.25	670	1.19	1.60	750	1.45	1.95	815	1.72	2.30	880	2.01	2.70	940	2.27	3.05
2480	5250	595	1.01	1.35	680	1.27	1.70	755	1.57	2.10	825	1.86	2.50	890	2.16	2.90	945	2.42	3.25
2595	5500	605	1.08	1.45	690	1.38	1.85	765	1.68	2.25	835	1.98	2.65	895	2.27	3.05	955	2.57	3.45
2715	5750	615	1.19	1.60	700	1.49	2.00	775	1.83	2.45	840	2.13	2.85	905	2.42	3.25	960	2.72	3.65
2830	6000	630	1.30	1.75	710	1.60	2.15	785	1.94	2.60	850	2.27	3.05	910	2.57	3.45	970	2.91	3.90
2950	6250	640	1.42	1.90	720	1.75	2.35	795	2.09	2.80	860	2.42	3.25	920	2.76	3.70	975	3.09	4.15
3070	6500	650	1.53	2.05	730	1.86	2.50	805	2.24	3.00	870	2.57	3.45	930	2.95	3.95	985	3.28	4.40
3185	6750	665	1.64	2.20	745	2.01	2.70	815	2.39	3.20	880	2.76	3.70	940	3.13	4.20	995	3.47	4.65
3305	7000	675	1.75	2.35	755	2.16	2.90	825	2.54	3.40	890	2.95	3.95	950	3.32	4.45	1005	3.69	4.95
3420	7250	690	1.94	2.60	765	2.31	3.10	835	2.72	3.65	900	3.09	4.15	955	3.47	4.65	1015	3.91	5.25
3540	7500	700	2.05	2.75	775	2.46	3.30	845	2.87	3.85	910	3.32	4.45	965	3.69	4.95	1020	4.10	5.50
3660	7750	715	2.24	3.00	790	2.65	3.55	855	3.06	4.10	920	3.50	4.70	975	3.91	5.25	1030	4.33	5.80
3775	8000	725	2.39	3.20	800	2.83	3.80	865	3.24	4.35	930	3.69	4.95	985	4.10	5.50	1040	4.55	6.10
3895	8250	740	2.54	3.40	810	2.98	4.00	880	3.47	4.65	940	3.91	5.25	995	4.36	5.85	1050	4.81	6.45
4010	8500	750	2.72	3.65	825	3.21	4.30	890	3.65	4.90	950	4.14	5.55	1005	4.59	6.15	1060	5.07	6.80
4130	8750	765	2.91	3.90	835	3.39	4.55	900	3.88	5.20	960	4.36	5.85	1015	4.81	6.45	1070	5.33	7.15
4250	9000	780	3.13	4.20	850	3.62	4.85	910	4.10	5.50	970	4.59	6.15	1025	5.07	6.80	1080	5.59	7.50
4365	9250	790	3.32	4.45	860	3.84	5.15	925	4.36	5.85	985	4.88	6.55	1040	5.37	7.20	1090	5.85	7.85
4485	9500	805	3.54	4.75	875	4.06	5.45	935	4.59	6.15	995	5.15	6.90	1050	5.67	7.60	1100	6.15	8.25
4600	9750	820	3.77	5.05	885	4.29	5.75	950	4.88	6.55	1005	5.37	7.20	1060	5.93	7.95	1110	6.45	8.65
4720	10 000	835	4.03	5.40	900	4.59	6.15	960	5.11	6.85	1015	5.67	7.60	1070	6.23	8.35	1120	6.75	9.05
4835	10 250	845	4.21	5.65	910	4.81	6.45	970	5.37	7.20	1030	5.97	8.00	1080	6.52	8.75	1135	7.12	9.55
4955	10 500	860	4.47	6.00	925	5.11	6.85	985	5.70	7.65	1040	6.26	8.40	1095	6.86	9.20	1145	7.46	10.00
5075	10 750	875	4.77	6.40	940	5.41	7.25	1000	6.00	8.05	1055	6.60	8.85	1105	7.20	9.65	1155	7.79	10.45
5190	11 000	890	5.07	6.80	950	5.67	7.60	1010	6.30	8.45	1065	6.94	9.30	1115	7.49	10.05	1165	8.13	10.90

CONTINUED ON NEXT PAGE

BLOWER DATA

BLOWER TABLE INCLUDES RESISTANCE FOR BASE UNIT ONLY WITH DRY INDOOR COIL & AIR FILTERS IN PLACE
FOR ALL UNITS ADD:

- 1 - Wet indoor coil air resistance of selected unit.
- 2 - Any factory installed options air resistance (electric heat, economizer, etc.)
- 3 - Any field installed accessories air resistance (electric heat, duct resistance, diffuser, etc.)

Then determine from blower table blower motor output and drive required.

See page 29 for wet coil and option/accessory air resistance data.

See page 29 for factory installed drive kit specifications.

MINIMUM AIR VOLUME REQUIRED FOR USE WITH OPTIONAL ELECTRIC HEAT

LCH156H units require 2455 L/s (5200 cfm) minimum air with electric heat.

All other units require 2830 L/s (6000 cfm) minimum air with electric heat.

Air Volume		TOTAL STATIC PRESSURE - Pa (Inches Water Gauge)																	
		400 (1.60)			450 (1.80)			500 (2.00)			550 (2.20)			600 (2.40)			650 (2.60)		
L/s	cfm	rev/min	kW	BHP	rev/min	kW	BHP	rev/min	kW	BHP	rev/min	kW	BHP	rev/min	kW	BHP	rev/min	kW	BHP
1890	4000	965	1.94	2.60	1020	2.16	2.90	1070	2.42	3.25	1115	2.65	3.55	1160	2.87	3.85	1205	3.09	4.15
2005	4250	970	2.09	2.80	1025	2.31	3.10	1075	2.57	3.45	1120	2.80	3.75	1165	3.06	4.10	1210	3.32	4.45
2125	4500	980	2.24	3.00	1030	2.46	3.30	1080	2.72	3.65	1130	3.02	4.05	1175	3.24	4.35	1215	3.50	4.70
2240	4750	985	2.39	3.20	1040	2.65	3.55	1085	2.91	3.90	1135	3.17	4.25	1180	3.47	4.65	1225	3.73	5.00
2360	5000	995	2.54	3.40	1045	2.83	3.80	1095	3.09	4.15	1140	3.36	4.50	1185	3.65	4.90	1230	3.95	5.30
2480	5250	1000	2.72	3.65	1050	2.98	4.00	1100	3.28	4.40	1150	3.58	4.80	1195	3.88	5.20	1235	4.18	5.60
2595	5500	1010	2.87	3.85	1060	3.17	4.25	1110	3.50	4.70	1155	3.80	5.10	1200	4.10	5.50	1240	4.40	5.90
2715	5750	1015	3.06	4.10	1065	3.36	4.50	1115	3.69	4.95	1160	3.99	5.35	1205	4.33	5.80	1250	4.66	6.25
2830	6000	1025	3.24	4.35	1075	3.58	4.80	1120	3.88	5.20	1170	4.21	5.65	1215	4.55	6.10	1255	4.88	6.55
2950	6250	1030	3.43	4.60	1080	3.77	5.05	1130	4.10	5.50	1175	4.44	5.95	1220	4.81	6.45	1265	5.15	6.90
3070	6500	1040	3.62	4.85	1090	3.99	5.35	1140	4.36	5.85	1185	4.70	6.30	1225	5.03	6.75	1270	5.41	7.25
3185	6750	1045	3.80	5.10	1095	4.18	5.60	1145	4.55	6.10	1190	4.92	6.60	1235	5.29	7.10	1275	5.67	7.60
3305	7000	1055	4.03	5.40	1105	4.44	5.95	1155	4.81	6.45	1200	5.18	6.95	1240	5.56	7.45	1285	5.97	8.00
3420	7250	1065	4.29	5.75	1115	4.66	6.25	1160	5.03	6.75	1205	5.44	7.30	1250	5.85	7.85	1290	6.23	8.35
3540	7500	1075	4.51	6.05	1125	4.92	6.60	1170	5.33	7.15	1215	5.70	7.65	1260	6.15	8.25	1300	6.52	8.75
3660	7750	1080	4.74	6.35	1130	5.15	6.90	1180	5.59	7.50	1225	6.00	8.05	1265	6.41	8.60	1305	6.82	9.15
3775	8000	1090	5.00	6.70	1140	5.41	7.25	1185	5.85	7.85	1230	6.26	8.40	1275	6.71	9.00	1315	7.16	9.60
3895	8250	1100	5.26	7.05	1150	5.70	7.65	1195	6.15	8.25	1240	6.60	8.85	1280	7.01	9.40	1325	7.49	10.05
4010	8500	1110	5.52	7.40	1160	6.00	8.05	1205	6.45	8.65	1250	6.90	9.25	1290	7.35	9.85	1330	7.79	10.45
4130	8750	1120	5.78	7.75	1165	6.23	8.35	1215	6.75	9.05	1255	7.20	9.65	1300	7.68	10.30	1340	8.13	10.90
4250	9000	1130	6.08	8.15	1175	6.52	8.75	1220	7.01	9.40	1265	7.53	10.10	1310	8.05	10.80	1350	8.50	11.40
4365	9250	1140	6.38	8.55	1185	6.86	9.20	1230	7.35	9.85	1275	7.87	10.55	1315	8.35	11.20	---	---	---
4485	9500	1150	6.67	8.95	1195	7.16	9.60	1240	7.68	10.30	1285	8.24	11.05	---	---	---	---	---	---
4600	9750	1160	7.01	9.40	1205	7.49	10.05	1250	8.05	10.80	1295	8.58	11.50	---	---	---	---	---	---
4720	10 000	1170	7.31	9.80	1215	7.83	10.50	1260	8.39	11.25	---	---	---	---	---	---	---	---	---
4835	10 250	1180	7.64	10.25	1225	8.20	11.00	---	---	---	---	---	---	---	---	---	---	---	---
4955	10 500	1190	7.98	10.70	1235	8.54	11.45	---	---	---	---	---	---	---	---	---	---	---	---
5075	10 750	1200	8.35	11.20	---	---	---	---	---	---	---	---	---	---	---	---	---	---	---
5190	11 000	---	---	---	---	---	---	---	---	---	---	---	---	---	---	---	---	---	---

BLOWER DATA

FACTORY INSTALLED BELT DRIVE KIT SPECIFICATIONS

Nominal kW	Nominal hp	Maximum kW	Maximum hp	Drive Kit Number	Rev/min Range
1.5	2	1.7	2.30	1	446 - 604
1.5	2	1.7	2.30	2	571 - 721
2.2	3	2.6	3.45	3	571 - 721
2.2	3	2.6	3.45	4	708 - 871
3.7	5	4.3	5.75	3	571 - 721
3.7	5	4.3	5.75	4	708 - 871
3.7	5	4.3	5.75	5	788 - 988
5.6	7.5	6.4	8.63	6	708 - 871
5.6	7.5	6.4	8.63	7	788 - 988
5.6	7.5	6.4	8.63	8	871 - 1071
7.5	10	8.6	11.50	7	788 - 988
7.5	10	8.6	11.50	10	871 - 1071
7.5	10	8.6	11.50	11	945 - 1138

NOTE - Using total air volume and system static pressure requirements determine from blower performance tables rev/min and motor output required. Maximum usable output of motors furnished are shown. If motors of comparable output are used, be sure to keep within the service factor limitations outlined on the motor nameplate.

FACTORY INSTALLED OPTIONS/FIELD INSTALLED ACCESSORY AIR RESISTANCE

Air Volume		Wet Indoor Coil				Humiditrol® Condenser Reheat Coil		Electric Heat		Economizer		Filters				Horizontal Roof Curb			
		156H, 180H		210H, 240H, 300S								MERV 8		MERV 13		156H thru 240H		300S	
L/s	cfm	Pa	in. w.g.	Pa	in. w.g.	Pa	in. w.g.	Pa	in. w.g.	Pa	in. w.g.	Pa	in. w.g.	Pa	in. w.g.	Pa	in. w.g.	Pa	in. w.g.
1890	4000	5	0.02	10	0.04	5	0.02	---	---	---	---	2	0.01	10	0.04	15	0.06	5	0.02
2005	4250	5	0.02	10	0.04	5	0.02	---	---	---	---	2	0.01	12	0.05	17	0.07	5	0.02
2125	4500	5	0.02	12	0.05	5	0.02	---	---	---	---	2	0.01	12	0.05	17	0.07	5	0.02
2240	4750	5	0.02	12	0.05	5	0.02	---	---	---	---	5	0.02	12	0.05	20	0.08	7	0.03
2360	5000	5	0.02	12	0.05	5	0.02	---	---	---	---	5	0.02	15	0.06	20	0.08	7	0.03
2475	5250	5	0.02	15	0.06	7	0.03	---	---	---	---	5	0.02	15	0.06	22	0.09	10	0.04
2595	5500	5	0.02	17	0.07	7	0.03	---	---	---	---	5	0.02	15	0.06	25	0.10	10	0.04
2715	5750	7	0.03	17	0.07	7	0.03	---	---	---	---	5	0.02	17	0.07	27	0.11	12	0.05
2830	6000	7	0.03	20	0.08	7	0.03	2	.01	---	---	7	0.03	17	0.07	27	0.11	15	0.06
2950	6250	7	0.03	20	0.08	7	0.03	2	.01	2	0.01	7	0.03	17	0.07	30	0.12	17	0.07
3065	6500	7	0.03	22	0.09	10	0.04	2	.01	5	0.02	7	0.03	20	0.08	32	0.13	20	0.08
3185	6750	10	0.04	25	0.10	10	0.04	2	.01	7	0.03	7	0.03	20	0.08	35	0.14	20	0.08
3305	7000	10	0.04	25	0.10	10	0.04	2	.01	10	0.04	10	0.04	20	0.08	37	0.15	22	0.09
3420	7250	10	0.04	27	0.11	10	0.04	2	.01	12	0.05	10	0.04	22	0.09	40	0.16	25	0.10
3540	7500	12	0.05	30	0.12	12	0.05	2	.01	15	0.06	10	0.04	22	0.09	42	0.17	27	0.11
3775	8000	12	0.05	32	0.13	12	0.05	5	.02	22	0.09	12	0.05	25	0.10	47	0.19	32	0.13
4010	8500	15	0.06	37	0.15	12	0.05	5	.02	27	0.11	12	0.05	25	0.10	52	0.21	37	0.15
4245	9000	17	0.07	40	0.16	15	0.06	10	.04	35	0.14	15	0.06	27	0.11	60	0.24	42	0.17
4485	9500	20	0.08	45	0.18	17	0.07	12	.05	40	0.16	17	0.07	30	0.12	65	0.26	47	0.19
4720	10 000	20	0.08	50	0.20	17	0.07	15	.06	47	0.19	17	0.07	30	0.12	72	0.29	52	0.21
4955	10 500	22	0.09	55	0.22	20	0.08	22	.09	55	0.22	20	0.08	32	0.13	77	0.31	60	0.24
5191	11 000	27	0.11	60	0.24	20	0.08	27	.11	62	0.25	22	0.09	35	0.14	85	0.34	67	0.27

BLOWER DATA

POWER EXHAUST FAN PERFORMANCE

Return Air System Static Pressure		Air Volume Exhausted	
Pa	in. w.g.	L/s	cfm
0	0.00	4072	8630
12	0.05	3874	8210
25	0.10	3645	7725
37	0.15	3355	7110
50	0.20	3053	6470
62	0.25	2732	5790
75	0.30	2388	5060
87	0.35	2029	4300
99	0.40	1656	3510
112	0.45	1269	2690
124	0.50	868	1840

CEILING DIFFUSER AIR RESISTANCE

Air Volume		Step-Down Diffuser												Flush Diffuser			
		RTD11-185S						RTD11-275S						FD11-185S		FD11-275S	
		2 Ends Open		1 Side/2 Ends Open		All Ends & Sides Open		2 Ends Open		1 Side/2 Ends Open		All Ends & Sides Open					
L/s	cfm	Pa	in. w.g.	Pa	in. w.g.	Pa	in. w.g.	Pa	in. w.g.	Pa	in. w.g.	Pa	in. w.g.	Pa	in. w.g.	Pa	in. w.g.
2360	5000	127	0.51	109	0.44	97	0.39	---	---	---	---	---	---	67	0.27	---	---
2455	5200	139	0.56	119	0.48	104	0.42	---	---	---	---	---	---	75	0.30	---	---
2550	5400	152	0.61	129	0.52	112	0.45	---	---	---	---	---	---	82	0.33	---	---
2645	5600	164	0.66	139	0.56	119	0.48	---	---	---	---	---	---	90	0.36	---	---
2735	5800	177	0.71	147	0.59	127	0.51	---	---	---	---	---	---	97	0.39	---	---
2830	6000	189	0.76	157	0.63	137	0.55	90	0.36	77	0.31	67	0.27	104	0.42	72	0.29
2925	6200	199	0.80	169	0.68	147	0.59	---	---	---	---	---	---	114	0.46	---	---
3020	6400	214	0.86	179	0.72	157	0.63	---	---	---	---	---	---	124	0.50	---	---
3065	6500	---	---	---	---	---	---	104	0.42	90	0.36	77	0.31	---	---	85	0.34
3115	6600	229	0.92	191	0.77	167	0.67	---	---	---	---	---	---	134	0.54	---	---
3210	6800	246	0.99	206	0.83	179	0.72	---	---	---	---	---	---	144	0.58	---	---
3305	7000	256	1.03	216	0.87	189	0.76	122	0.49	102	0.41	90	0.36	154	0.62	99	0.40
3400	7200	271	1.09	229	0.92	199	0.80	---	---	---	---	---	---	164	0.66	---	---
3490	7400	286	1.15	241	0.97	209	0.84	---	---	---	---	---	---	174	0.70	---	---
3540	7500	---	---	---	---	---	---	127	0.51	114	0.46	102	0.41	---	---	112	0.45
3585	7600	298	1.20	254	1.02	219	0.88	---	---	---	---	---	---	184	0.74	---	---
3775	8000	---	---	---	---	---	---	147	0.59	122	0.49	107	0.43	---	---	124	0.50
4010	8500	---	---	---	---	---	---	172	0.69	144	0.58	124	0.50	---	---	142	0.57
4245	9000	---	---	---	---	---	---	196	0.79	167	0.67	144	0.58	---	---	164	0.66
4485	9500	---	---	---	---	---	---	221	0.89	186	0.75	162	0.65	---	---	184	0.74
4720	10 000	---	---	---	---	---	---	249	1.00	209	0.84	182	0.73	---	---	201	0.81
4955	10 500	---	---	---	---	---	---	274	1.10	229	0.92	199	0.80	---	---	221	0.89
5190	11 000	---	---	---	---	---	---	301	1.21	251	1.01	219	0.88	---	---	239	0.96

CEILING DIFFUSER AIR THROW DATA

Model No.	Air Volume		1 Effective Throw Range				Model No.	Air Volume		1 Effective Throw Range			
	L/s	cfm	RTD11-185S Step-Down		FD11-185S Flush			L/s	cfm	RTD11-185S Step-Down		FD11-185S Flush	
			m	ft.	m	ft.				m	ft.		
												m	ft.
156 180	2645	5600	12 - 15	39 - 49	9 - 11	28 - 37	210 240 300	3400	7200	10 - 12	33 - 38	8 - 11	26 - 35
	2735	5800	13 - 16	42 - 51	9 - 12	29 - 38		3490	7400	11 - 12	35 - 40	9 - 11	28 - 37
	2830	6000	13 - 16	44 - 54	12 - 15	40 - 50		3585	7600	11 - 12	36 - 41	9 - 11	29 - 38
	2925	6200	14 - 17	45 - 55	13 - 16	42 - 51		3680	7800	12 - 13	38 - 43	12 - 15	40 - 50
	3020	6400	14 - 17	46 - 55	13 - 16	43 - 52		3775	8000	12 - 13	39 - 44	13 - 16	42 - 51
	3115	6600	14 - 17	47 - 56	14 - 17	45 - 56		3870	8200	12 - 14	41 - 46	13 - 16	43 - 52
								3965	8400	13 - 15	43 - 49	13 - 16	44 - 54
								4060	8600	13 - 15	44 - 50	14 - 17	46 - 57
								4155	8800	14 - 17	47 - 55	15 - 18	48 - 59

¹ Throw is the horizontal or vertical distance an airstream travels on leaving the outlet or diffuser before the maximum velocity is reduced to 15 m (50 ft.) per minute. Four sides open.

ELECTRICAL/ELECTRIC HEAT DATA

		LCH156H4	LCH180H4	LCH210H4	LCH240H4	LCH300S4										
¹ Voltage - 50hz 3 Phase with neutral		380/420V	380/420V	380/420V	380/420V	380/420V										
Compressor 1	Rated Load Amps	6.3	6.3	7.8	6.3	8										
	Locked Rotor Amps	55	55	51.5	55	67.1										
Compressor 2	Rated Load Amps	6.3	6.3	7.8	6.3	8										
	Locked Rotor Amps	55	55	51.5	55	67.1										
Compressor 3	Rated Load Amps	6.3	6.3	8	6.3	10.6										
	Locked Rotor Amps	55	55	67.1	55	74										
Compressor 4	Rated Load Amps	---	---	---	6.3	10.6										
	Locked Rotor Amps	---	---	---	55	74										
Outdoor Fan Motors	Number of motors	3	4	6	6	6										
	Full Load Amps (total)	1.3 (3.9)	1.3 (5.2)	1.3 (7.8)	1.3 (7.8)	1.3 (7.8)										
Power Exhaust With (2) 0.25 kW	Full Load Amps (total)	1.3 (2.6)	1.3 (2.6)	1.3 (2.6)	1.3 (2.6)	1.3 (2.6)										
	kW	1.5	2.2	3.7	2.2	3.7	5.6	2.2	3.7	5.6	3.7	5.6	7.5	3.7	5.6	7.5
Indoor Blower Motor	Full Load Amps	3.6	5.3	8.2	5.3	8.2	11.7	5.3	8.2	11.7	8.2	11.7	16.3	8.2	11.7	16.3
	Unit Only	30	35	40	35	40	50	45	45	50	50	50	60	60	70	80
¹ Maximum Overcurrent Protection	With (2) 0.25 kW Power Exhaust	35	35	40	35	45	50	45	50	60	50	60	70	60	70	80
	Unit Only	28	30	34	31	35	39	39	42	47	44	48	54	56	60	66
² Minimum Circuit Ampacity	With (2) 0.25 kW Power Exhaust	31	33	36	34	37	42	42	44	49	46	51	56	59	63	68
	Unit Only	28	30	34	31	35	39	39	42	47	44	48	54	56	60	66

ELECTRIC HEAT DATA

Electric Heat Voltage			420	420	420	420	420	420	420	420	420	420	420	420	420	420	
¹ Maximum Overcurrent Protection	Unit+ 11.5 kW		30	35	40	35	40	50	45	45	50	50	50	60	60	70	80
	⁴ Electric Heat 23 kW		45	50	50	50	50	60	50	50	60	50	60	60	60	70	80
	34.5 kW		70	70	70	70	70	80	70	70	80	70	80	80	70	80	80
	45.9 kW		70	70	80	70	80	80	70	80	80	80	80	90	80	80	90
	68.9 kW		---	---	---	---	---	---	110	110	110	110	110	125	110	110	125
² Minimum Circuit Ampacity	Unit+ 11.5 kW		28	30	34	31	35	39	39	42	47	44	48	54	56	60	66
	⁴ Electric Heat 23 kW		44	47	50	47	50	55	46	50	55	50	55	60	56	60	66
	34.5 kW		64	66	70	66	70	74	66	69	74	70	74	80	70	74	80
	45.9 kW		68	70	74	70	74	78	70	73	78	74	78	84	74	78	84
	68.9 kW		---	---	---	---	---	---	101	105	110	105	110	116	105	110	116
¹ Maximum Overcurrent Protection	Unit+ 11.5 kW		35	35	40	35	45	50	45	50	60	50	60	70	60	70	80
	⁴ Electric Heat 23 kW		50	50	60	50	60	60	50	60	60	60	60	70	60	70	80
	and (2) 0.25 kW Power Exhaust 34.5 kW		70	70	80	70	80	80	70	80	80	80	80	90	80	80	90
	45.9 kW		80	80	80	80	80	90	80	80	90	80	90	90	80	90	90
	68.9 kW		---	---	---	---	---	---	110	110	125	110	125	125	110	125	125
² Minimum Circuit Ampacity	Unit+ 11.5 kW		31	33	36	34	37	42	42	44	49	46	51	56	59	63	68
	⁴ Electric Heat 23 kW		48	50	53	50	53	58	49	53	58	53	58	64	59	63	68
	and (2) 0.25 kW Power Exhaust 34.5 kW		67	70	73	70	73	78	69	73	78	73	78	83	73	78	83
	45.9 kW		71	74	77	74	77	82	73	77	82	77	82	87	77	82	87
	68.9 kW		---	---	---	---	---	---	105	108	113	109	113	119	109	113	119

¹ Extremes of operating range are plus and minus 10% of line voltage.

² Heating / Air Conditioning / Refrigeration (HACR) type breaker or fuse.

³ Refer to local codes to determine wire, fuse and disconnect size requirements.

⁴ Nominal kW based on 420V-3ph-50hz.

ELECTRIC HEAT CAPACITIES

Volts Input	11.5 kW			23 kW			34.5 kW			45.9 kW			68.9 kW		
	kW Input	Btuh Output	No. of Stages	kW Input	Btuh Output	No. of Stages	kW Input	Btuh Output	No. of Stages	kW Input	Btuh Output	No. of Stages	kW Input	Btuh Output	No. of Stages
380	9.4	32 100	1	18.8	64 200	1	28.2	96 300	2	37.6	128 400	2	56.4	192 500	2
400	10.4	35 600	1	20.8	71 100	1	31.2	106 700	2	41.6	142 200	2	62.5	213 200	2
420	11.5	39 200	1	23.0	78 400	1	34.4	117 600	2	45.9	156 800	2	68.9	235 100	2

UNIT CLEARANCES

Unit With Economizer

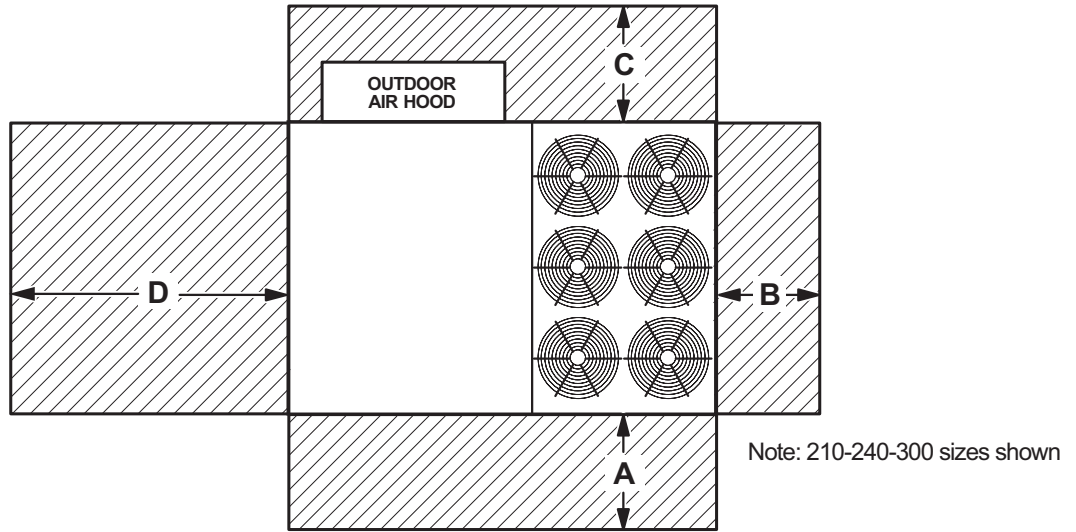

¹ Unit Clearance	A		B		C		D		Top Clearance
	mm	in.	mm	in.	mm	in.	mm	in.	
Service Clearance	1524	60	914	36	914	36	1676	66	Unobstructed
Minimum Operation Clearance	1143	45	914	36	914	36	1041	41	

NOTE - Entire perimeter of unit base requires support when elevated above the mounting surface.

¹ Service Clearance - Required for removal of serviceable parts.

Minimum Operation Clearance - Required clearance for proper unit operation.

OUTDOOR SOUND DATA

Unit Model Number	Octave Band Linear Sound Power Levels dB, re 10 ⁻¹² Watts - Center Frequency - Hz							¹ Sound Rating Number (SRN) (dBA)
	125	250	500	1000	2000	4000	8000	
156	71	78	81	81	76	71	63	86
180	80	83	87	88	84	80	71	93
210, 240, 300	79	84	88	89	85	82	73	94

Note - The octave sound power data does not include tonal corrections.

¹ Sound Rating Number according to ARI Standard 370-2001 (includes pure tone penalty). "SRN" is the overall A-Weighted Sound Power Level, (LWA), dB (100 Hz to 10,000 Hz).

WEIGHT DATA

Model Number	Outdoor Coil	Net		Shipping		Outdoor Coil	Net		Shipping	
		kg	lbs.	kg	lbs.		kg	lbs.	kg	lbs.
156 Base Unit	Environ™	810	1785	900	1985	Fin/Tube	839	1850	930	2050
156 Max. Unit	Environ™	937	2065	1027	2265	Fin/Tube	966	2130	1057	2330
180 Base Unit	Environ™	891	1965	982	2165	Fin/Tube	939	2070	1030	2270
180 Max. Unit	Environ™	1018	2245	1109	2445	Fin/Tube	1066	2350	1157	2550
210 Base Unit	Environ™	948	2090	1039	2290	Fin/Tube	989	2180	1080	2380
210 Max. Unit	Environ™	1080	2380	1170	2580	Fin/Tube	1120	2470	1211	2670
240 Base Unit	Environ™	987	2175	1077	2375	Fin/Tube	1034	2280	1125	2480
240 Max. Unit	Environ™	1118	2465	1209	2665	Fin/Tube	1166	2570	1256	2770
300 Base Unit	Environ™	1044	2302	1135	2502	Fin/Tube	1073	2367	1164	2567
300 Max. Unit	Environ™	1176	2592	1266	2792	Fin/Tube	1205	2657	1296	2857

OPTIONS / ACCESSORIES

Description	Shipping Weight		
	kg	lbs.	
ECONOMIZER / OUTDOOR AIR / EXHAUST			
Economizer			
Economizer Dampers	46	102	
Barometric Relief Dampers (downflow)	14	30	
Barometric Relief Dampers (horizontal)	9	20	
Outdoor Air Damper Hood (downflow)	29	65	
Outdoor Air Dampers			
Outdoor Air Damper Section (downflow) - Automatic (including Hood)	39	18	
Outdoor Air Damper Section (downflow) - Manual (including Hood)	22	10	
Power Exhaust	28	62	
ELECTRIC HEAT			
10.4 kW	27	59	
20.8 kW	27	59	
31.2 kW	34	76	
41.6 kW	34	76	
62.5 kW	38	84	
HUMIDITROL® DEHUMIDIFICATION SYSTEM			
Humiditrol® Dehumidification System (Net Weight)	23	50	
ROOF CURBS			
Hybrid Roof Curbs, Downflow			
203 mm height	34	75	
356 mm height	48	105	
457 mm height	57	125	
610 mm height	70	155	
Adjustable Pitch Curb, Downflow			
356 mm height	119	262	
Horizontal Roof Curbs, Standard			
660 mm height	231	470	
940 mm height	229	505	
762 mm height	261	575	
1041 mm height	277	610	
CEILING DIFFUSERS			
Step-Down			
	RTD11-185S	168	76
	RTD11-275S	238	108
Flush			
	FD11-185S	168	76
	FD11-275S	238	108
Transitions			
	C1DIFF33C-1	36	80
	C1DIFF34C-1	34	75
PACKAGING			
LTL Packaging (less than truck load)	141	310	

DIMENSIONS - UNIT

LCH156

CORNER WEIGHTS

CENTER OF GRAVITY

Model No.	AA		BB		CC		DD		EE		FF	
	kg	lbs.	kg	lbs.	kg	lbs.	kg	lbs.	mm	in.	mm	in.
LCH156 Base Unit (Environ™ Coil)	195	428	157	346	207	456	252	554	1232	48-1/2	1003	39-1/2
LCH156 Max. Unit (Environ™ Coil)	244	538	195	429	222	489	277	609	1219	48	1086	42-3/4
LCH156 Base Unit (Fin/Tube Coil)	195	431	171	376	220	486	253	557	1276	50-1/4	1010	39-3/4
LCH156 Max. Unit (Fin/Tube Coil)	245	540	208	459	235	519	277	611	1257	49-1/2	1086	42-3/4

Base Unit - The unit with NO INTERNAL OPTIONS.

Max. Unit - The unit with ALL INTERNAL OPTIONS Installed. (Economizer, Standard Static Power Exhaust Fans, Controls, etc.). Does not include accessories external to unit or high static power exhaust.

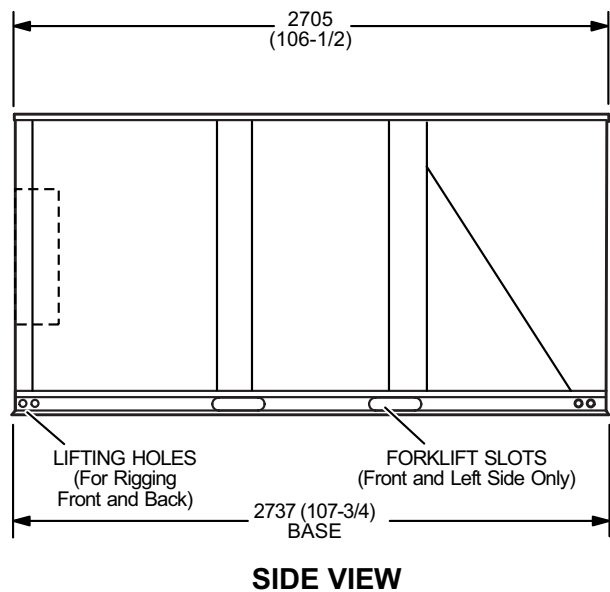
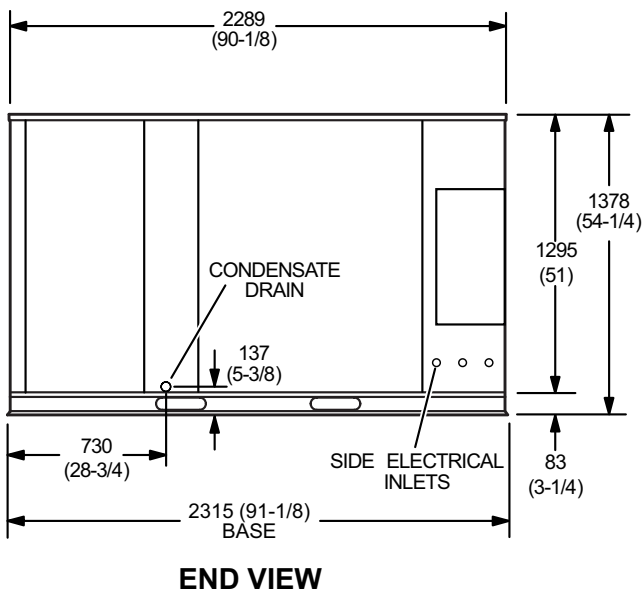
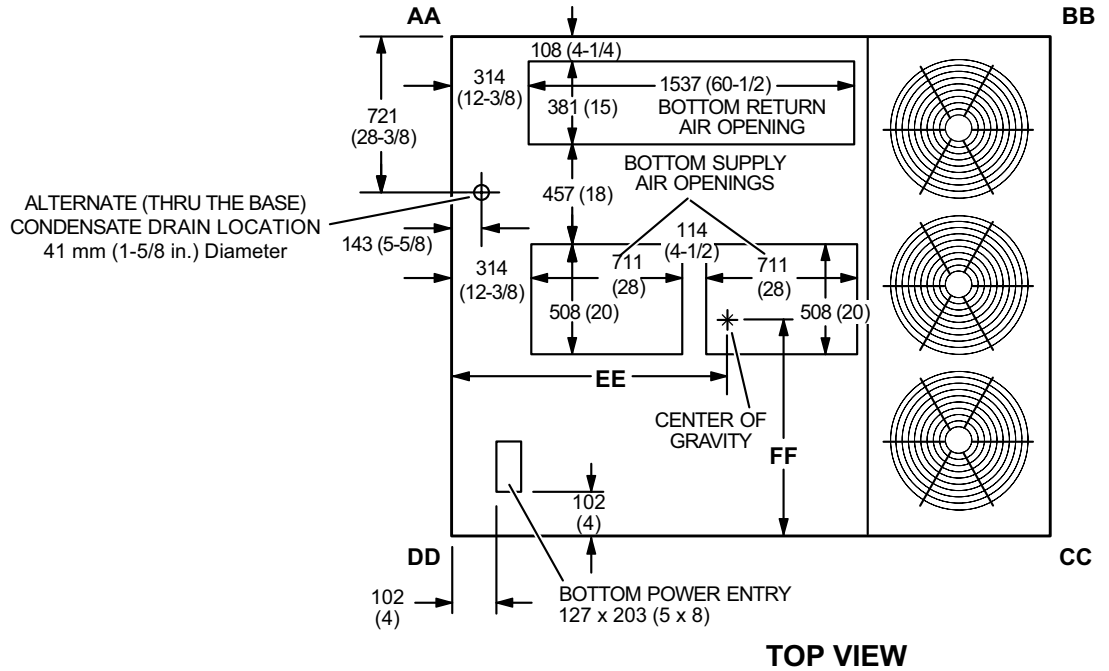

DIMENSIONS - UNIT

LCH180

Model No.	CORNER WEIGHTS								CENTER OF GRAVITY			
	AA		BB		CC		DD		EE		FF	
	kg	lbs.	kg	lbs.	kg	lbs.	kg	lbs.	mm	in.	mm	in.
LCH180 Base Unit (Environ™ Coil)	201	441	183	403	247	543	262	577	1321	52	997	39-1/4
LCH180 Max. Unit (Environ™ Coil)	248	545	221	485	262	577	290	638	1295	51	1067	42
LCH180 Base Unit (Fin/Tube Coil)	200	441	207	456	270	596	262	577	1391	54-3/4	1003	39-1/2
LCH180 Max. Unit (Fin/Tube Coil)	247	545	244	538	285	629	289	638	1359	53-1/2	1067	42

Base Unit - The unit with NO INTERNAL OPTIONS.

Max. Unit - The unit with ALL INTERNAL OPTIONS Installed. (Economizer, Standard Static Power Exhaust Fans, Controls, etc.). Does not include accessories external to unit or high static power exhaust.

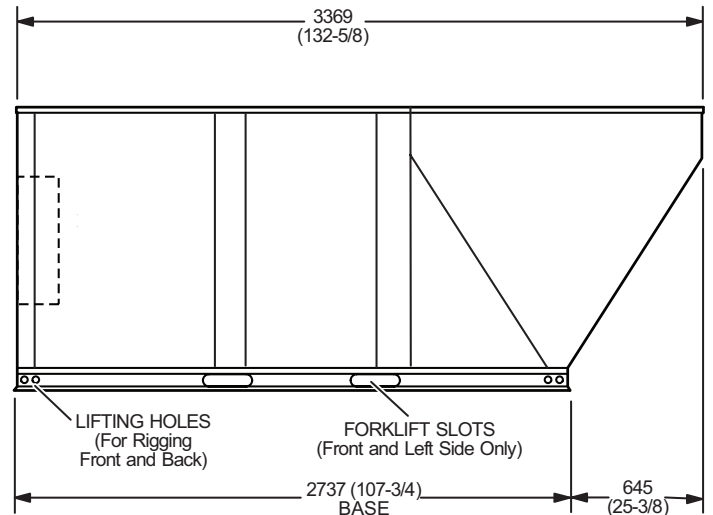
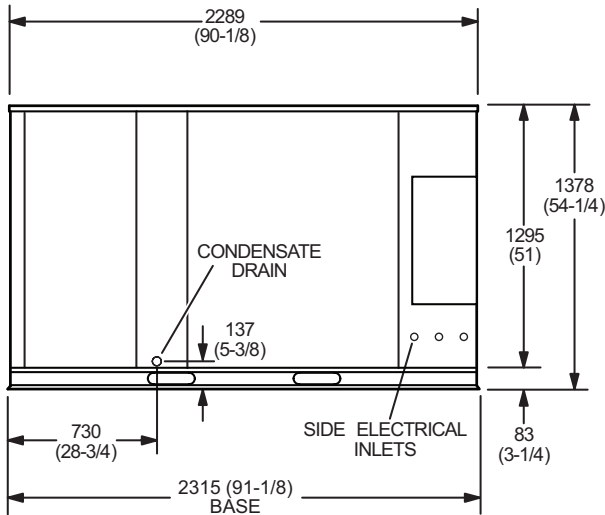
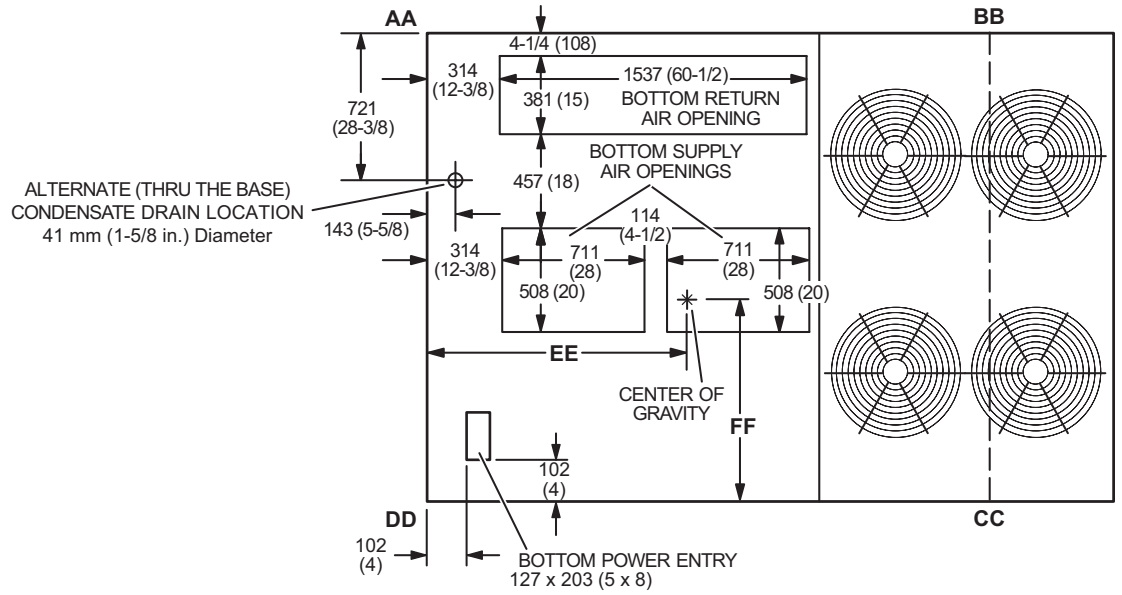

DIMENSIONS

LCH210, LCH240, LCH300

CORNER WEIGHTS

CENTER OF GRAVITY

Model No.	AA		BB		CC		DD		EE		FF	
	kg	lbs.	kg	lbs.	kg	lbs.	kg	lbs.	mm	in.	mm	in.
LCH210 Base Unit (Environ™ Coil)	205	452	204	448	273	600	268	590	1372	54	997	39-1/4
LCH210 Max. Unit (Environ™ Coil)	253	557	244	536	288	635	296	652	1346	53	1067	42
LCH210 Base Unit (Fin/Tube Coil)	205	452	224	493	293	645	268	590	1429	56-1/4	1003	39-1/2
LCH210 Max. Unit (Fin/Tube Coil)	253	557	264	581	308	680	296	652	1397	55	1067	42
LCH240 Base Unit (Environ™ Coil)	210	462	210	461	288	634	281	617	1384	54-1/2	984	38-3/4
LCH240 Max. Unit (Environ™ Coil)	258	568	250	550	304	668	308	679	1359	53-1/2	1054	41-1/2
LCH240 Base Unit (Fin/TubeCoil)	210	462	233	514	312	687	280	617	1441	56-3/4	991	39
LCH240 Max. Unit (Fin/TubeCoil)	258	568	274	603	327	721	308	679	1410	55-1/2	1054	41-1/2
LCH300 Base Unit (Environ™ Coil)	212	466	221	487	313	689	300	660	1399	55	958	37-5/7
LCH300 Max. Unit (Environ™ Coil)	261	574	263	578	329	723	326	718	1373	54	1028	40-1/2
LCH300 Base Unit (Fin/Tube Coil)	213	469	235	518	329	724	298	656	1436	56-1/2	965	38
LCH300 Max. Unit (Fin/Tube Coil)	261	575	275	606	344	758	327	719	1405	55-1/3	1028	40-1/2

Base Unit - The unit with NO INTERNAL OPTIONS.

Max. Unit - The unit with ALL INTERNAL OPTIONS installed. (Economizer, Standard Static Power Exhaust Fans, Controls, etc.). Does not include accessories external to unit or high static power exhaust.

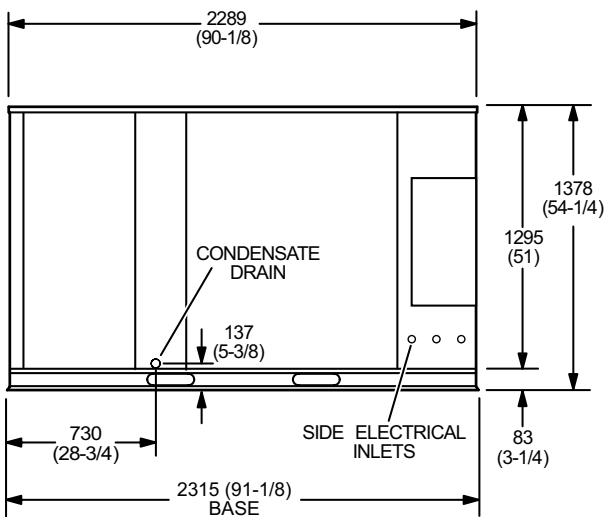
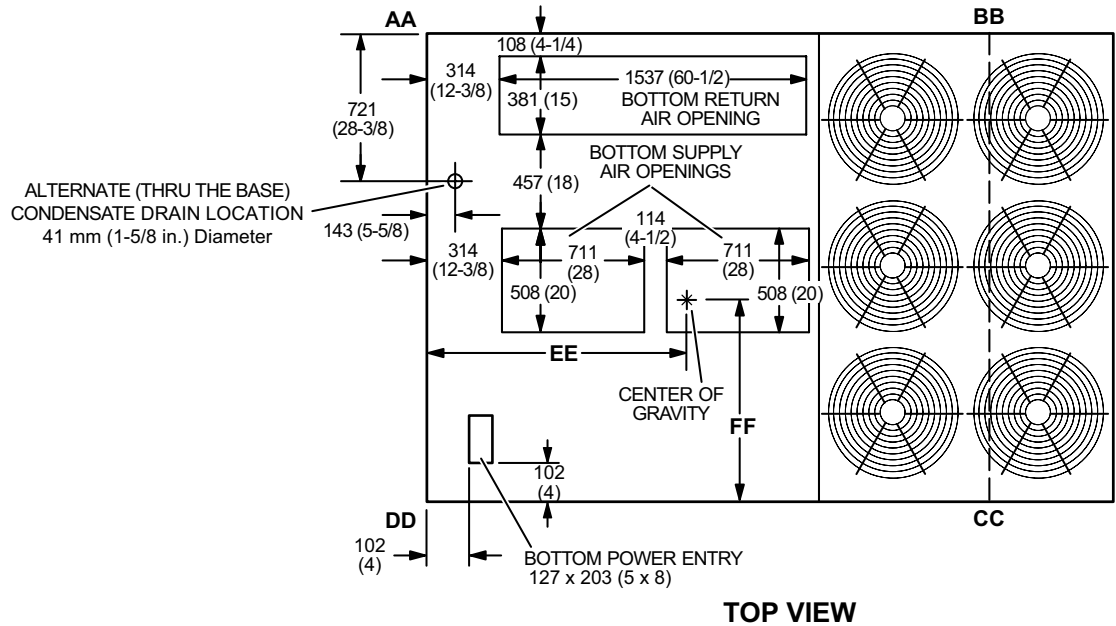

END VIEW

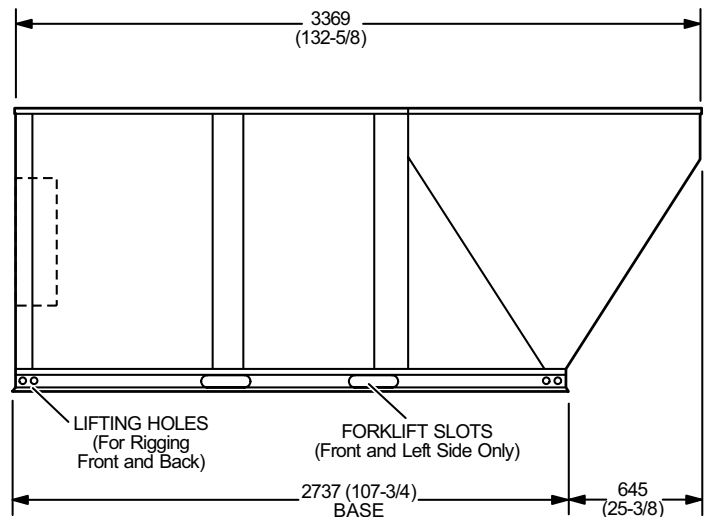

SIDE VIEW

OUTDOOR AIR HOOD DETAIL

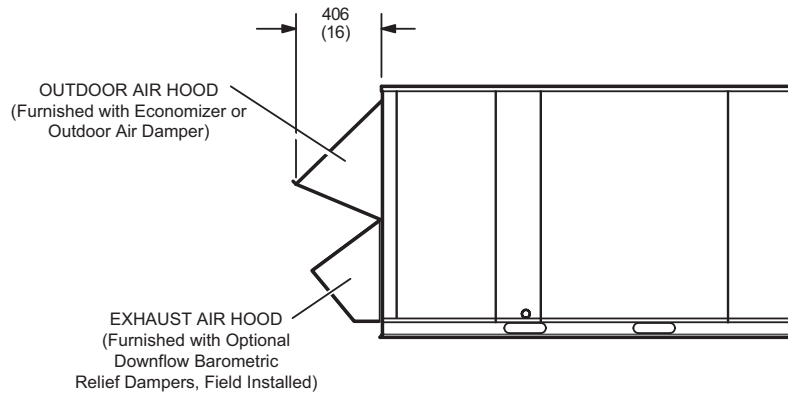

OPTIONAL HORIZONTAL BAROMETRIC RELIEF DAMPERS WITH HOOD

(Field installed in horizontal return air duct adjacent to unit)

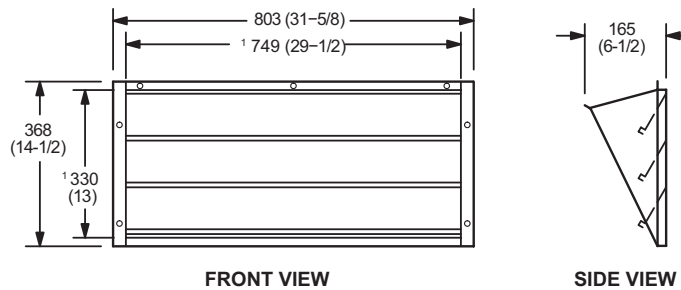

NOTE - Two furnished per order number.
¹ NOTE - Opening size required in return air duct.

ADJUSTABLE PITCH CURB - DOUBLE DUCT OPENING

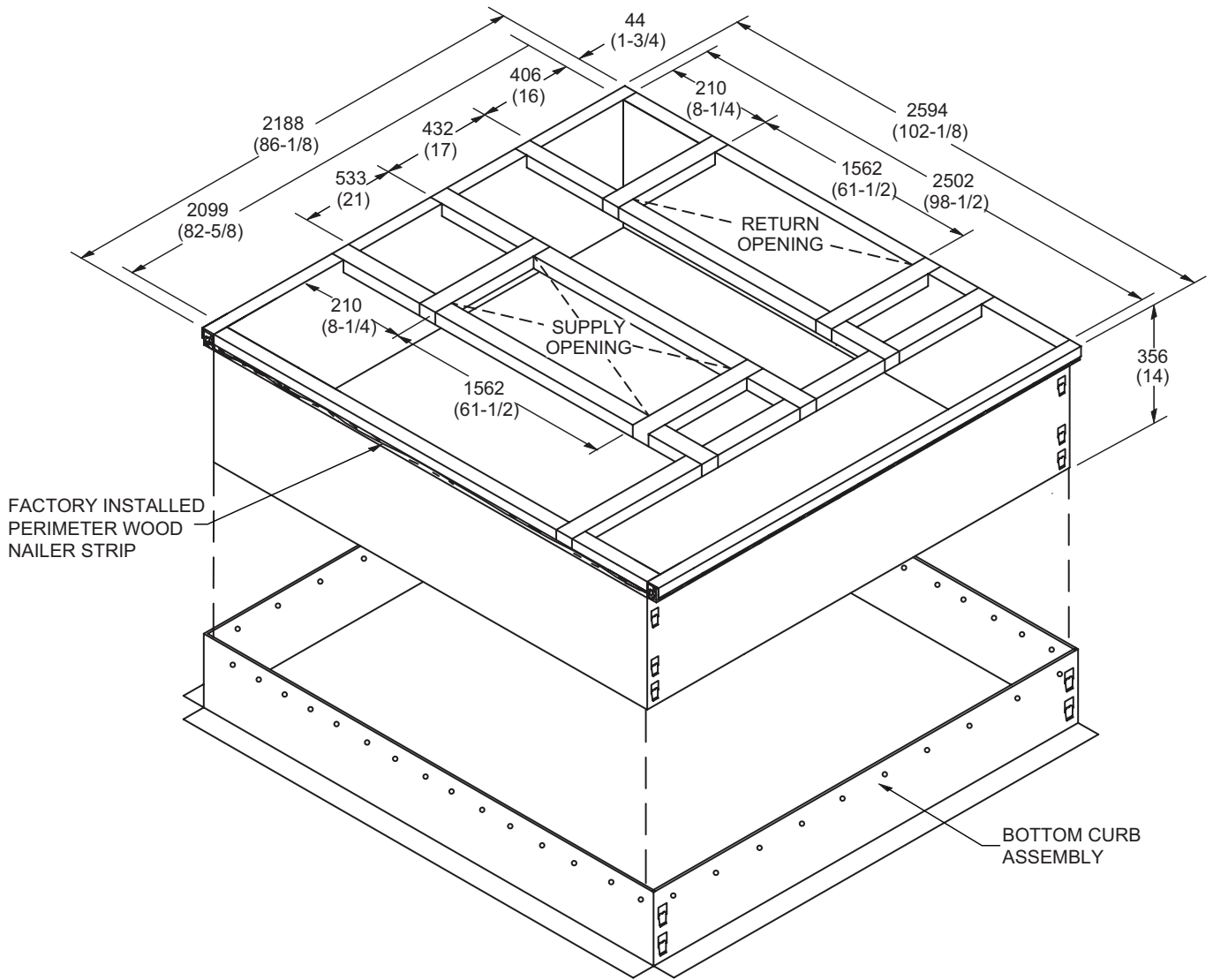

NOTE - Maximum slope pitch is 19 mm per 305 mm (3/4 inch per foot) in any one direction.

TYPICAL FLASHING DETAIL FOR ROOF CURB

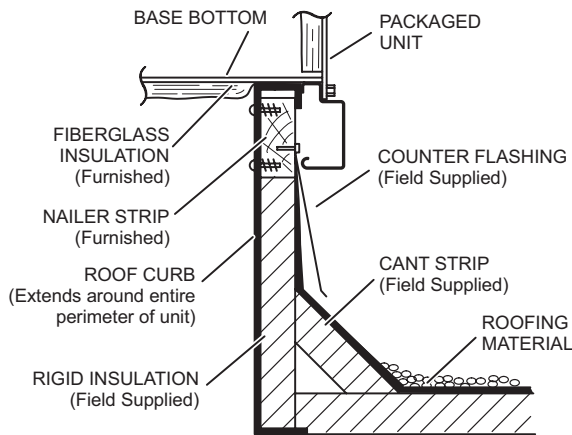

DETAIL ROOF CURB

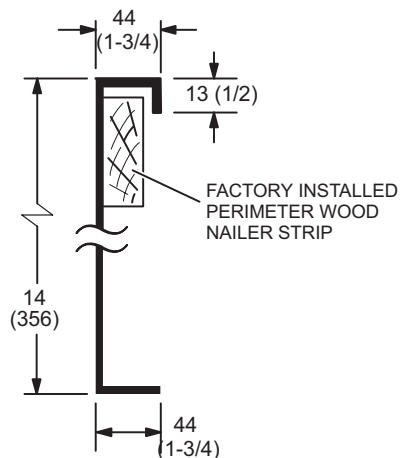

ROOF CURBS WITH SUPPLY & RETURN AIR TRANSITIONS FOR CEILING DIFFUSERS

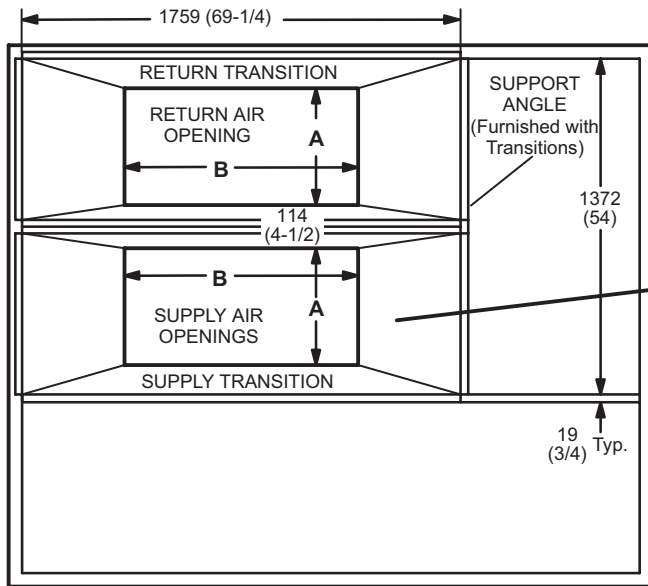

TOP VIEW

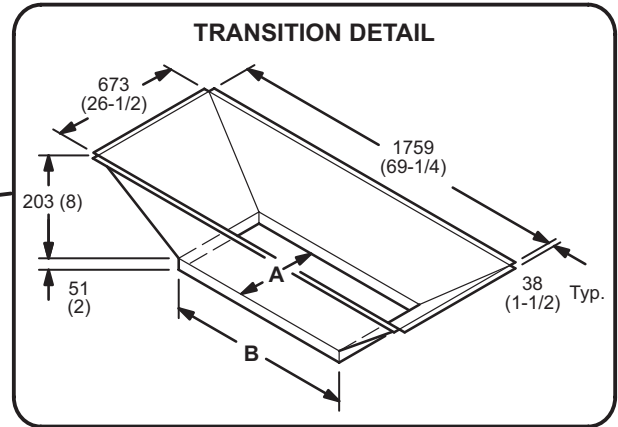

TRANSITION OPENING SIZES

Model Number	A		B	
	mm	inch	mm	inch
C1DIFF33C-1	457	18	914	36
C1DIFF34C-1	610	24	1219	48

HORIZONTAL ROOF CURBS – Requires Optional Horizontal Return Air Panel Kit

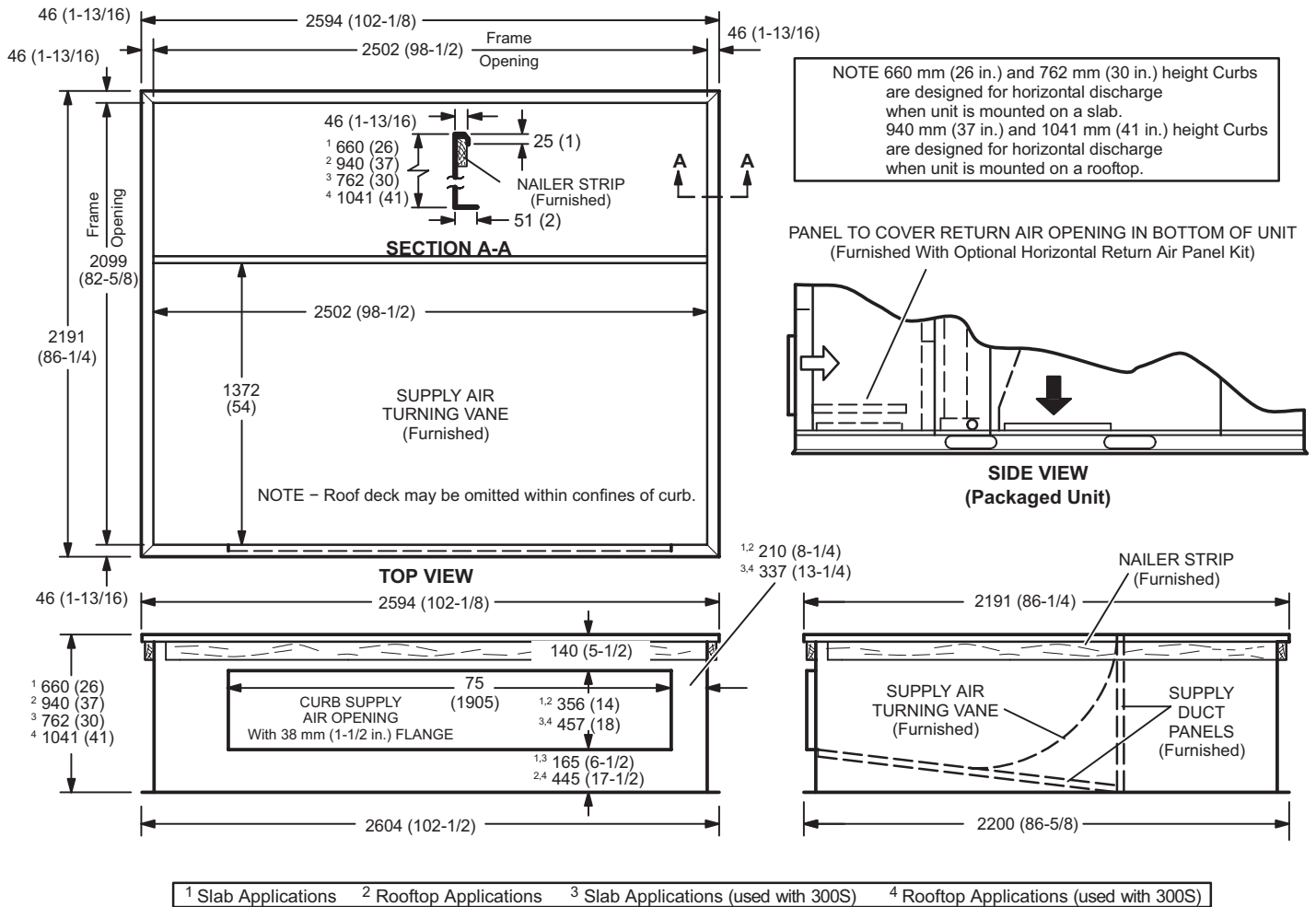

HORIZONTAL SUPPLY AND RETURN AIR OPENINGS WITH HORIZONTAL ROOF CURB

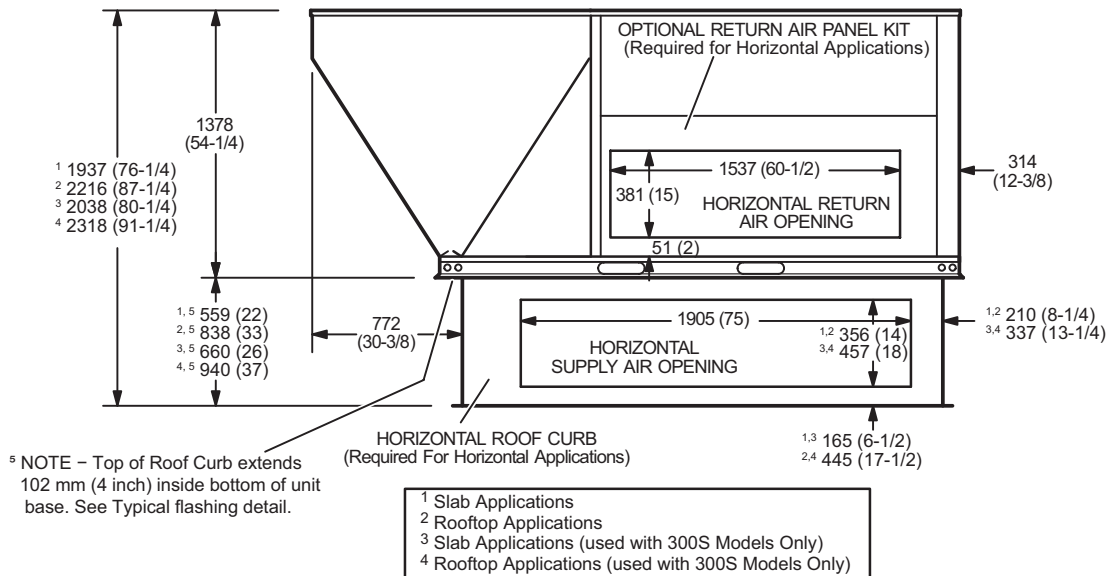

COMBINATION CEILING SUPPLY AND RETURN DIFFUSERS

STEP-DOWN CEILING DIFFUSER

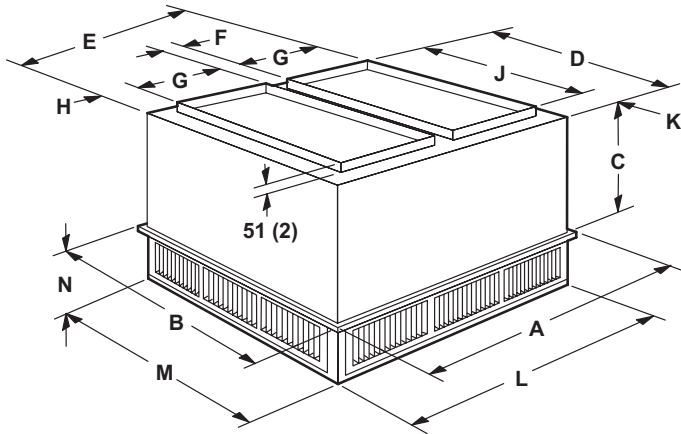

FLUSH CEILING DIFFUSER

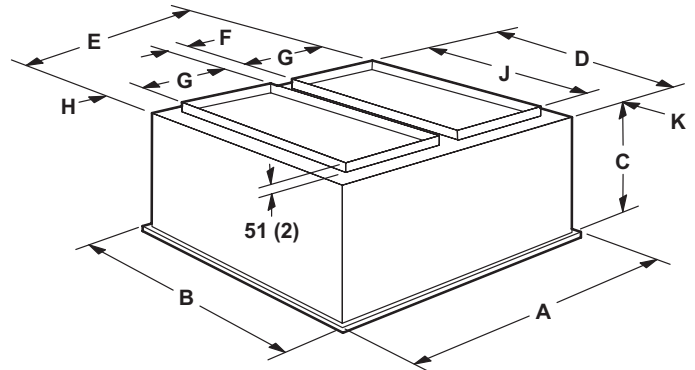

Model Number		RTD11-185S	RTD11-275S
A	mm	1210	1514
	in.	47-5/8	59-5/8
B	mm	1210	1514
	in.	47-5/8	59-5/8
C	mm	625	778
	in.	24-5/8	30-5/8
D	mm	1156	1461
	in.	45-1/2	57-1/2
E	mm	1156	1461
	in.	45-1/2	57-1/2
F	mm	114	114
	in.	4-1/2	4-1/2
G	mm	457	610
	in.	18	24
H	mm	64	64
	in.	2-1/2	2-1/2
J	mm	914	1219
	in.	36	48
K	mm	121	121
	in.	4-3/4	4-3/4
L	mm	1156	1461
	in.	45-1/2	57-1/2
M	mm	1156	1461
	in.	45-1/2	57-1/2
N	mm	257	283
	in.	10-1/8	11-1/8
Duct Size	mm	457 x 914	610 x 1219
	in.	18 x 36	24 x 48

Model Number		FD11-185S	FD11-275S
A	mm	1210	1514
	in.	47-5/8	59-5/8
B	mm	1210	1514
	in.	47-5/8	59-5/8
C	mm	743	895
	in.	29-1/4	35-1/4
D	mm	1143	1148
	in.	45	57
E	mm	1143	1448
	in.	45	57
F	mm	114	114
	in.	4-1/2	4-1/2
G	mm	457	610
	in.	18	24
H	mm	57	57
	in.	2-1/4	2-1/4
J	mm	914	1219
	in.	36	48
K	mm	114	114
	in.	4-1/2	4-1/2
Duct Size	mm	457 x 914	610 x 1219
	in.	18 x 36	24 x 48

REVISIONS

Sections	Description of Change
Options/Accessories	Catalog numbers revised for: Blower Proving Switch Discharge Air Temperature Switch Disconnects Economizers Electric Heat Float Switch Gravity Exhaust Dampers Power Exhaust Single Enthalpy Smoke Detectors



Visit us at www.lennox.com

For the latest technical information, www.lennoxcommercial.com

Contact us at 1-800-4-LENNOX

NOTE - Due to Lennox' ongoing commitment to quality, Specifications, Ratings and Dimensions subject to change without notice and without incurring liability. Improper installation, adjustment, alteration, service or maintenance can cause property damage or personal injury. Installation and service must be performed by a qualified installer and servicing agency.

©2021 Lennox Industries, Inc.