



COMMERCIAL
PRODUCT SPECIFICATIONS

Bulletin No. 490152
 March 2021
 Supersedes June 2019



SMARTWIRE™ SYSTEM



88 to 105 kW (25 to 30 Tons)
Net Cooling Capacity - 74.4 to 88.5 kW (254 000 to 302 000 Btuh)
Optional Electric Heat - 23 to 91.9 kW

MODEL NUMBER IDENTIFICATION

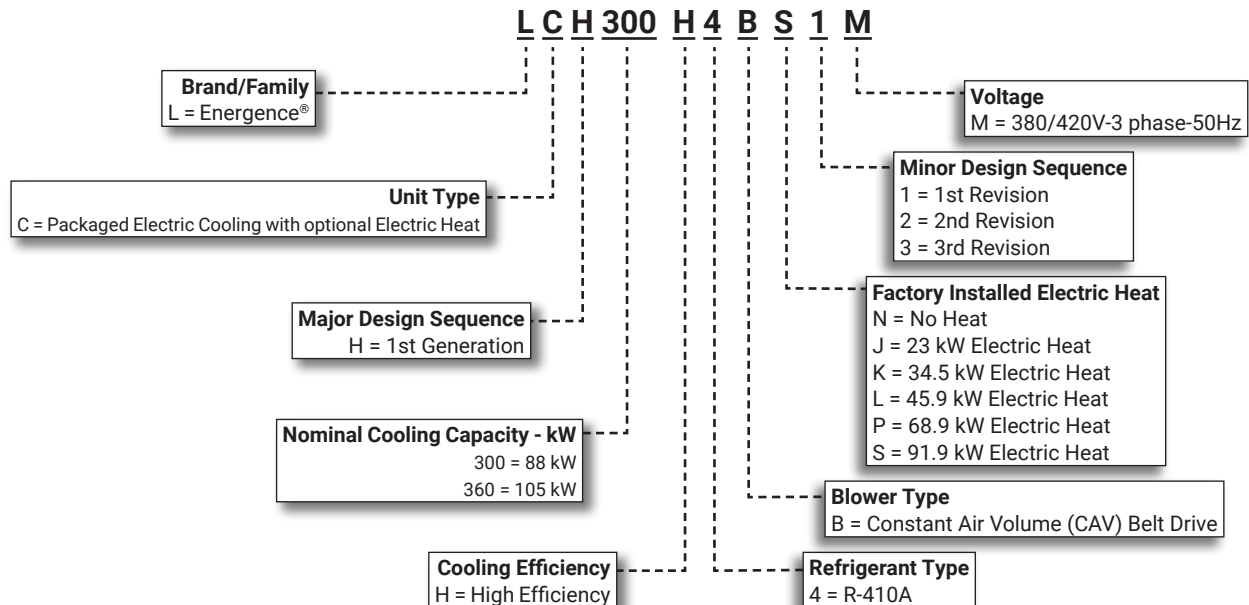

FEATURE HIGHLIGHTS

Lennox' Energence® packaged rooftop unit product line was created to save energy with intelligence by offering some of the highest energy efficiency ratings available with a powerful, easy to use unit controller. This makes Energence rooftop units perfect for business owners looking for an Heating/Ventilation/Air Conditioning (HVAC) product with the lowest total cost of ownership.

1. Scroll Compressors
2. Condenser Coil
3. Thermal Expansion Valves
4. Filters/Driers
5. Outdoor Coil Fan Motors
6. Construction
7. Hinged Access Panels
8. Blower
9. Electric Heat
10. Air Filters
11. Unit Controller
12. Economizer
13. Downflow Barometric Relief Dampers

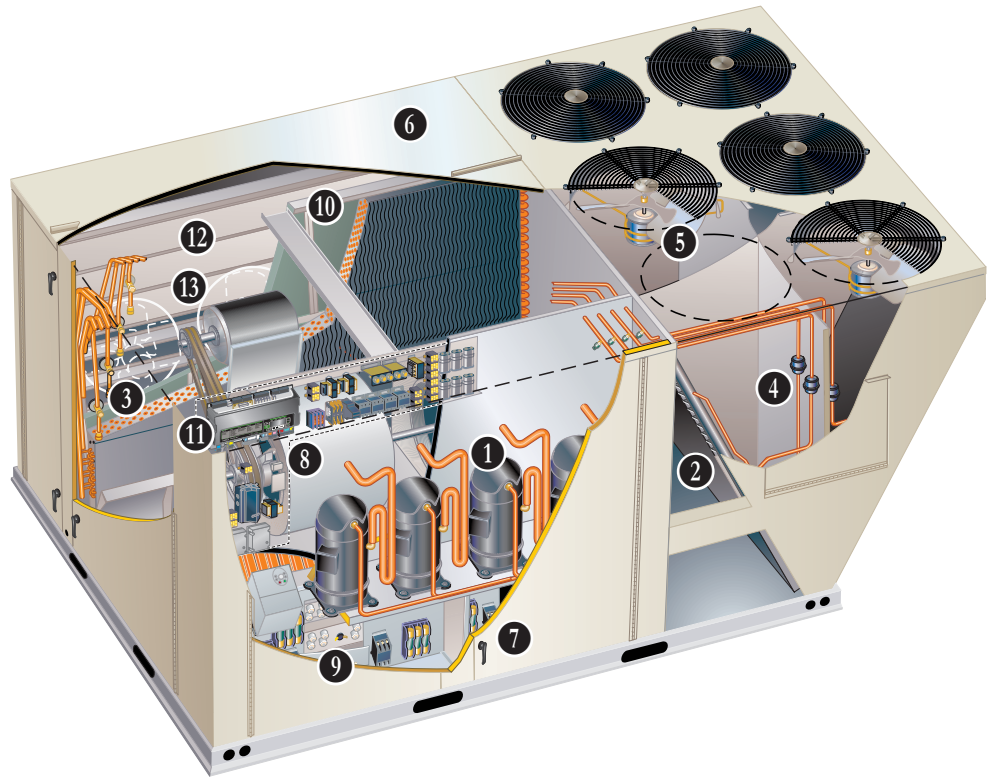

CONTENTS

Blower Data	18
Dimensions	24
- Unit	24
- Accessories	25
Electrical/Electric Heat Data	22
Electric Heat Capacities	22
Electric Heat Data	22
Optional Conventional Temperature Control Systems	9
Options / Accessories	11
Outdoor Sound Data	12
Ratings	16
Specifications	15
Weight Data	12
- Unit	12
- Options / Accessories	12

PERFORMANCE/QUALITY

- Components bonded for grounding to meet safety standards for servicing required by Underwriters Laboratories (UL) and the International Electrotechnical Commission (IEC)
- Cooling performance is rated at test conditions included in Air-Conditioning, Heating and Refrigeration (AHRI) Standard 340/360-2007 while operating at rated voltage and air volumes. International Organization for Standardization (ISO) 9001
- Registered Manufacturing Quality System

FEATURES AND BENEFITS

COOLING SYSTEM

- Designed to maximize sensible and latent cooling performance at design conditions
- System can operate from -18°C to 52°C without any additional controls

R-410A Refrigerant

- Non-chlorine
- Ozone friendly
- Unit pre-charged with refrigerant; see Specification table

1 Scroll Compressors

- Scroll compressors on all models for high performance, reliability and quiet operation
- Resiliently mounted on rubber grommets for quiet operation

Compressor Crankcase Heaters

- Protects against refrigerant migration that can occur during low ambient operation or during extended off cycles

2 Condenser Coil - Lennox' Environ™ Coil System

- Lightweight, all aluminum brazed fin construction
- Constructed of three components
 - A flat extrusion tube
 - Fins in-between the flat extrusion tube
 - Two refrigerant manifolds

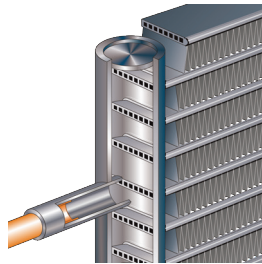

Environ™ Coil System Features:

- Improved heat transfer performance due to high primary surface area (flat tubes) versus secondary surface (fins)
- Smaller internal volume (reduced refrigerant charge)
- High durability
- All aluminum construction
- Fewer brazed joints
- Compact design
- Reduced unit weight
- Easy maintenance/cleaning
- Face split design
- Mounting brackets with rubber inserts
- Angled cabinet design protects coil from damage

Evaporator Coil

- Copper tube construction
- Enhanced rippled-edge aluminum fins
- Flared shoulder tubing connections
- Silver-soldered construction
- Factory leak tested
- Cross row circuiting with rifled tubing
- Low fin per inch count minimizes air pressure drop

NOTE - All models have face-split evaporator coils designed to keep condensate water off of an inactive part of the coil so the condensate will not re-enter the air stream.

3 Thermal Expansion Valves

- Ensures optimal performance throughout the application range
- Removable element head

4 Filter/Driers

- High capacity filter/drier protects the system from dirt and moisture

High Pressure Switches

- Protects the compressor from overload conditions such as dirty condenser coils, blocked refrigerant flow, or loss of outdoor fan operation

Low Pressure Switches

- Protects the compressors from low pressure conditions such as low refrigerant charge, or low/no airflow

Condensate Drain Pan

- Plastic, sloped drain pan
- Side drain connections

NOTE - Stainless steel drain pan available as a factory installed option.

Freezestats

- Protects the evaporator coil from damaging ice build-up due to conditions such as low/no airflow, or low refrigerant charge

5 Outdoor Coil Fan Motors

- Thermal overload protected
- Totally enclosed
- Permanently lubricated ball bearings
- Shaft up
- Wire basket mount

Outdoor Coil Fans

- Polyvinyl chloride (PVC) coated fan guard furnished

FEATURES AND BENEFITS

COOLING SYSTEM (continued)

Required Selections

Cooling Capacity

- Specify nominal cooling capacity

Options/Accessories

Factory Installed

Discharge Air Temperature Sensor

- Sensor sends information to the unit controller to cycle up to 2 stages of heating or 4 stages of cooling to maintain the discharge air setpoints for heating or cooling
- Optional for units with single zone or bypass zoning control

NOTE - Sensor is shipped with the unit for remote field installation in the supply duct.

Factory or Field Installed

Condensate Drain Trap

- Field installed only, may be factory enclosed to ship with unit
- Available in copper or Polyvinyl chloride (PVC)

Drain Pan Overflow Switch

- Monitors condensate level in drain pan
- Shuts down unit if drain becomes clogged

Stainless Steel Drain Pan

- Non-corrosive drain pan

CABINET

6 Construction

- Heavy-gauge steel panels
- Full perimeter heavy-gauge galvanized steel base rail
- Base rails have rigging holes
- Three sides of the base rail have forklift slots
- Raised edges around duct and power entry openings in the bottom for water protection

Airflow Choice

- Units are available in downflow (vertical) or horizontal return air flow configuration

NOTE - Units can be field converted to horizontal air flow with optional Horizontal Return Air Panel Kit and Horizontal Roof Curb.

Power Entry

- Electrical lines can be brought through the unit base or through horizontal access knock-outs

Exterior Panels

- Constructed of heavy-gauge, galvanized steel
- Two-layer enamel paint finish

Insulation

- Fully insulated with non-hygroscopic fiberglass insulation (conditioned areas)
- Unit base is fully insulated
- Base insulation serves as an air seal to the roof curb, eliminating the need to add a seal during installation

7 Hinged Access Panels

- Filter section
- Blower section
- Heating section
- Compressor/controls section
- Panel seals and quarter-turn latching handles provide a tight air and water seal

FEATURES AND BENEFITS

8 BLOWER

- A wide selection of supply air blower options are available to meet a variety of airflow requirements

Motor

- Overload protected
- Ball bearings
- Belt drive motors are offered on all models and are available in several different sizes to maximize air performance

Supply Air Blower

- Forward curved blades
- Double inlet
- Adjustable pulley (allows speed change)
- Blower assembly slides out of unit for servicing
- Grease fittings furnished

Required Selections

- Specify motor output and drive kit number when base unit is ordered, see Drive Kit Specifications tables
- Order one drive kit, see Drive Kit Specifications Table

Options/Accessories

Factory Installed

Blower Belt Auto-Tensioner

- Provides proper tension to belt drive blower belt without the need for regular adjustments
- Maintains airflow and proper performance

Field Installed

Supply Static Limit Switch

- Field installed manual reset switch for supply static high pressure limit
- Prevents exceeding pressure limit in supply air duct. Optional Mounting Kit includes tubing and adaptors

ELECTRICAL

NOTE - All units include terminal block and fuse block in power entry junction box for single power entry application.

SmartWire™ System

- Keyed and color-coded to prevent miswiring
- Wire coloring scheme is standardized across all models
- Each connection is intuitively labeled to make troubleshooting and servicing quick and easy

Required Selections

Voltage Choice

- Specify when ordering base unit

Options/Accessories

Factory or Field Installed

9 Electric Heat

- Electric heat is CE marked
- Helix wound nichrome elements
- Individual element limit controls

- Wiring harness
- Unit fuse block
- See Options/Accessories tables for ordering information

Options/Accessories

Factory Installed

Corrosion Protection

- A completely flexible immersed coating with an electrodeposited dry film process (AST ElectroFin E-Coat); meets Mil Spec MIL-P-53084, ASTM B117 Standard Method Salt Spray Testing

Indoor Corrosion Protection:

- Coated coil
- Painted blower housing
- Painted indoor base

Outdoor Corrosion Protection:

- Coated coil
- Painted outdoor base

Combination Coil/Hail Guards

- Heavy gauge steel frame painted to match cabinet with expanded metal mesh to protect the outdoor coil from damage

Grille Guards

- Protects the space between outdoor coils and main cabinet

Horizontal Return Air Panel Kit

- Required for horizontal applications with Horizontal Roof Curb, contains panel with return air opening for field replacement of existing unit panel and panel to cover bottom return air opening in unit, see dimension drawings

INDOOR AIR QUALITY

10 Air Filters

- Disposable 51 mm filters furnished as standard

Options/Accessories

Factory or Field Installed

Healthy Climate® High Efficiency Air Filters

- Disposable MERV 8 or MERV 13 (Minimum Efficiency Reporting Value based on ASHRAE 52.2) efficiency 51 mm pleated filters

Replacement Filter Media Kit With Frame

- Replaces existing pleated filter media
- Includes washable metal mesh screen and metal frame with clip for holding replaceable non-pleated filter

Field Installed

Indoor Air Quality (CO₂) Sensors

- Monitors CO₂ levels, reports to the Prodigy® Unit Controller, which adjusts economizer dampers as needed

CONTROL SYSTEM

PRODIGY UNIT CONTROLLER



- 11 The Prodigy® unit controller is a microprocessor-based controller that provides flexible control of all unit functions

Features

- LCD Display
- Easy to read menu (4 lines x 20 character display)
- Menu navigation LEDs for Data, Setup, Service, Settings
- Main Menu and Help Buttons for quick navigation to home screen and built-in help functions
- Scroll, Value Adjustment Select and Save Buttons
- Setup menu ensures proper installation and setup of the rooftop unit
- Profile setup copies key settings between units with the same configuration to reduce setup time
- USB port allows a technician to download and transfer unit information to help verify service was performed
- USB software updates on the Prodigy® Control System enhance functionality without the need to change components
- Unit Controller Software
- Unit self-test verifies individual critical component and system performance
- Economizer test function assures economizer is operating correctly
- Time Clock with Run-Time Information

Built-In Functions Include

- Adjustable Blower On/Off Delay
- Built-in Control Parameter Defaults
- Compressor Time-Off Delay
- DDC Compatible
- Dirty Filter Switch Input
- Discharge Air Temperature Control
- Display/Sensor Readout
- Economizer Control Options (See Economizer / Outdoor Air / Exhaust Options)
- Fresh Air Tempering
- Over 100 diagnostic and status messages in English
- Exhaust Fan Control Modes for fresh air damper position
- Permanent Diagnostic Code Storage
- Field Adjustable Control Parameters (Over 200 settings)
- Indoor Air Quality Input (Demand Control Ventilation)
- Low Ambient Controls - Cooling operation down to -18°C
- Gas Valve Time Delay Between First and Second Stage
- Minimum Compressor Run Time
- Network Capable (Can be daisy chained to other units or controls)

- Night Setback Mode
- Return Air Temperature Limit Control
- Safety Switch Input - Allows Controller to respond to a external safety switch trip.
- Service Relay Output
- Smoke Alarm Mode - Four choices (unit off, positive pressure, negative pressure, purge)
- Up to 2 heat/2 cool (standard Prodigy® unit controller thermostat input)
- Up to 3 cool with additional relay
- Up to 4 cool with room sensor or network operation
- "Strike Three" Protection
- Gas Reheat Control - Simultaneous heating and cooling operation for controlling humidity for process air applications such as supermarkets
- On Demand Dehumidification - Monitors and controls condenser hot gas reheat operation with Humiditrol® option
- Thermostat Bounce Delay
- Warm Up Mode Delay
- LED Indicators
- PC Interface - Connect to the Prodigy® unit controller from a PC with the Lennox Unit Controller Software
- Room Sensor Operation - Controls temperature

Controls Options

Factory or Field Installed

Fresh Air Tempering

- Used in applications with high outside air requirements
- Controller energizes the first stage heat as needed to maintain a minimum supply air temperature for comfort, regardless of the thermostat demand
- When ordered as a factory option, sensor ships with the unit for field installation

Smoke Detector

- Photoelectric type
- Installed in supply air section, return air section or both sections
- Available with power board and single sensor (supply or return) or power board and two sensors (supply and return)
- Power board located in unit control compartment

Interoperability via BACnet® or LonTalk® Protocols

- Communication compatible with third-party automation systems that support the BACnet Application Specific Controller device profile, LonMark® Space Comfort Controller functional profile, or LonMark Discharge Air Controller functional profile

OPTIONS / ACCESSORIES

12 ECONOMIZER

- Economizer operation is set and controlled by the Prodigy® Unit Controller
- Simple plug-in connections from economizer to unit controller for easy installation

NOTE - Optional sensors may be used instead of unit sensors to determine whether outdoor air is suitable for free cooling. See Options/Accessories table.

Factory or Field Installed

High Performance

- Low leakage dampers are Air Movement and Control Association International (AMCA) Class 1A Certified - Maximum 3 CFM per sq. ft. leakage at 1 in. w.g.
- Gear-driven action
- High torque 24-volt fully-modulating spring return damper motor
- Return air and outdoor air dampers
- Plug-in connections to unit
- Stainless steel bearings
- Enhanced neoprene blade edge seals
- Flexible stainless steel jamb seals

NOTE - Refer to Installation Instructions for complete setup information.

Differential Sensible Control

- Factory setting
- Uses outdoor air and return air sensors that are furnished with the unit
- The Prodigy® Unit Controller compares outdoor air and return air
- When the outdoor air is below the configured setpoint and cooler than return air, the controller activates the economizer

NOTE - Differential Sensible Control can be configured in the field to provide Offset Differential Sensible Control or Single Sensible Control.

NOTE - In Offset Differential Sensible Control mode, the economizer is enabled if the temperature differential (offset) between outdoor air and return air reaches the configured setpoint. In Single Sensible Control mode, the economizer is enabled when outdoor air temperature falls below the configured setpoint.

NOTE - The Free Cooling default setting for outdoor air temperature sensor is 13°C.

Global Control

- The unit controller communicates with a DDC system with one global sensor (enthalpy or sensible)
- Determines whether outside air is suitable for free cooling on all units connected to the control system
- Sensor must be field provided

Factory or Field Installed

Single Enthalpy Temperature Control

- Outdoor air enthalpy sensor enables Economizer if the outdoor enthalpy is less than the setpoint of the control

Differential Enthalpy Control

- Order two Single Enthalpy Controls
- One is field installed in the return air section
- One is installed in the outdoor air section
- Allows the economizer control to select between outdoor air or return air, whichever has lower enthalpy

EXHAUST

Factory or Field Installed

13 Downflow Barometric Relief Dampers

- Allow relief of excess air
- Aluminum blade dampers prevent blow back and outdoor air infiltration during off cycle
- Bird screen furnished
- Exhaust hood for downflow barometric relief dampers is factory installed when dampers are factory installed with economizer
- Exhaust hood is furnished with dampers when ordered for field installation

Standard Static Power Exhaust Fans

- Three, 0.25 kW motors
- 508 mm propeller-type fans
- Five blades
- Total power input of 1125 W and a total air volume of 6040 L/s at 0 Pa.
- Motor is inherently protected
- Totally enclosed
- Installs internal to unit for downflow applications only with economizer option
- Provides exhaust air pressure relief
- Interlocked to run when return air dampers are closed and supply air blower is operating
- Fan runs based on air damper position (adjustable)
- Motor inherently protected
- Steel cabinet and hood painted to match unit

NOTE - Requires optional Downflow Economizer Barometric Relief Dampers. See Standard Static Power Exhaust Blower Tables.

Horizontal Barometric Relief Dampers

- For use when unit is configured for horizontal applications requiring an economizer
- Allows relief of excess air
- Aluminum blade dampers prevent blow back and outdoor air infiltration during off cycle
- Field installed in return air duct
- Bird screen and hood furnished

NOTE - Horizontal Economizer Conversion kit is available for field installation.

OPTIONS / ACCESSORIES

OUTDOOR AIR

Factory or Field Installed

Outdoor Air Damper - Downflow or Horizontal With Air Hood

- Linked mechanical dampers
- 0 to 25% (fixed) outdoor air adjustable
- Installs in unit
- Includes outdoor air hood
- Automatic model features fully modulating spring return damper motor with plug-in connection
- Manual model features parallel blade, gear-driven dampers with adjustable fixed position

NOTE - Minimum mixed air temperature in heating mode is -1°C. Maximum mixed air temperature in cooling mode is 32°C.

ROOF CURBS

- Nailer strip furnished
- Mates to unit
- US National Roofing Contractors Approved
- Shipped knocked down

Downflow

Hybrid Roof Curbs

- Interlocking tabs to fasten corners together
- No tools required
- Curb can also be fastened together with furnished hardware
- Available in 356, 457, and 610 mm heights

NOTE - See Options/Accessories table.

Horizontal

- Converts unit from downflow to horizontal (side) air flow
- Return air is on unit, supply air is on curb, see dimension drawings
- Available in 940 mm and 1041 mm heights

NOTE - Requires Horizontal Return Air Panel Kit

NOTE - Optional Insulation Kit is available to help prevent sweating.

CEILING DIFFUSERS

Field Installed

Ceiling Diffusers (Flush or Step-Down)

- White powder coat finish on diffuser face and grilles
- Insulated UL listed duct liner
- Diffuser box has collars for duct connection
- Step-down diffusers have double deflection blades
- Flush diffusers have fixed blades
- Provisions for suspending
- Internally sealed to prevent recirculation
- Removable return air grille
- Adapts to T-bar ceiling grids or plaster ceilings

Transitions (Supply and Return)

- Used with diffusers
- Installs in roof curb
- Galvanized steel construction
- Flanges furnished for duct connection to diffusers
- Fully insulated

OPTIONAL CONVENTIONAL TEMPERATURE CONTROL SYSTEMS

ComfortSense® 8500 Commercial 7-Day Programmable Thermostat

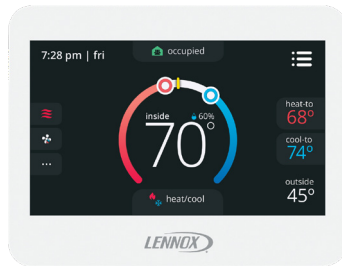

- Fully Communicating Sensor
- Full Color Touchscreen Interface
- Variable Speed System Control (On Compatible Units)
- Up To 4 Heat / 4 Cool
- Built-In Sensors For Temperature, Humidity And Optional CO₂
- Remote Sensor Options For Occupancy, Temperature
- BACnet Capable Options
- 5-2 or 7-Day Scheduling
- Smooth Setback Recovery
- Heat/Cool Auto-Changeover
- Four-Wire Installation
- FDD, ASHRAE, IECC Compliant

ComfortSense® 7500 Commercial 7-Day Programmable Thermostat



- Premium Universal Thermostat
- Full Color Touchscreen Interface
- Up To 4 Heat / 4 Cool
- Built-In Sensors For Temperature and Humidity
- Remote Sensors Options For Temperature, Discharge Air, Outdoor Air
- 5-2 or 7-Day Scheduling
- Smooth Setback Recovery
- Heat/Cool Auto-Changeover
- FDD, ASHRAE, IECC Compliant

ComfortSense® 3000 Commercial 5-2 Day Programmable Thermostat



- Conventional Multi-Stage Thermostat
- Intuitive Display
- Push-Button Operation
- Up To 2 Heat / 2 Cool
- Built-In Temperature Sensor
- Remote Temperature Sensing
- Up to 5-2 Day Scheduling
- Smooth Setback Recovery
- Heat/Cool Auto-changeover

Wired Room Sensor (LCS-5030)



- Simple Push-Button Override
- Variable Speed System Control (On Compatible Units)
- Up To 4 Heat / 4 Cool
- Built-In Temperature and Humidity Sensors
- AA Battery / 24VAC Powered
- SBUS Wired Operation
- Automatic Sensor Averaging
- Locking Hex Screw

OPTIONAL CONVENTIONAL TEMPERATURE CONTROL SYSTEMS

Description	Catalog No.
ComfortSense® 8500 Commercial 7 Day Programmable Thermostat	
CS8500 7-Day Thermostat	No CO ₂ Sensing 17G75
	With CO ₂ Sensing 17G76
Sensors/Accessories	¹ Remote non-adjustable wall-mount 10k 47W37
	¹ Remote non-adjustable wall-mount 11k 94L61
Sysbus Network Cable (Yellow) for ComfortSense 8500 and LCS-5030 Wired Room Sensor	
Twisted pair 100% shielded communication cable, Red and Black	500 ft. box 27M19
22 AWG, yellow jacket, rated at 75°C, 300V, Plenum rated	1000 ft. box 94L63
Insulation - Low smoke PVC, NEC, CMP	2500 ft. roll 68M25
ComfortSense® 7500 Commercial 7-Day Programmable Thermostat	
CS7500 7-Day Thermostat	17G74
Sensors/Accessories	² Remote non-adjustable wall-mount 20k 47W36
	² Remote non-adjustable wall-mount 10k 47W37
	Remote non-adjustable discharge air (duct mount) 19L22
	Outdoor temperature sensor X2658
ComfortSense® 3000 Commercial 5-2 Day Programmable Thermostat	
CS3000 5-2 Day Thermostat	11Y05
Sensors/Accessories	Remote non-adjustable wall mount 10k averaging 47W37
	Thermostat wall mounting plate X2659
ComfortSense® Non-Programmable Thermostat	
CS3000 Non-Programmable Thermostat	51M32
Universal Thermostat Guard with Lock (clear)	
	Inside Dimensions (H x W) 5 7/8 x 8 3/8 in. 39P21
Wired Room Sensor	
LCS-5030 Wired Room Sensor	21L07

¹ Up to nine of the same type remote temperature sensors can be connected in parallel.

² Remote wall-mount sensors can be applied in any of the following combinations:

One Sensor - (1) 47W36, Two Sensors - (2) 47W37, Three Sensors - (2) 47W36 and (1) 47W37

Four Sensors - (4) 47W36, Five Sensors - (3) 47W36 and (2) 47W37

OPTIONS / ACCESSORIES

Item Description	Model Number	Catalog Number	Unit Model No	
			300	360
COOLING SYSTEM				
Condensate Drain Trap	Polyvinyl chloride (PVC) - C1TRAP20AD2	22H54	OX	OX
	Copper - C1TRAP10AD2	76W27	OX	OX
Corrosion Protection		Factory	O	O
Drain Pan Overflow Switch	E1SNSR71AD1	21Z07	OX	OX
Efficiency	High	Factory	O	O
Refrigerant Type	R-410A	Factory	O	O
Plastic Condensate Drain Pan		Factory	O	O
Stainless Steel Condensate Drain Pan	C1DPAN10D-1-	83W42	OX	OX
BLOWER - SUPPLY AIR				
Motors	Belt Drive - 3.7 kW	Factory	O	O
	Belt Drive - 5.6 kW	Factory	O	O
	Belt Drive - 7.5 kW	Factory	O	O
Drive Kits See Blower Data Tables for usage and selection	Kit #1 615-745 rev/min	Factory	O	O
	Kit #2 725-870 rev/min	Factory	O	O
	Kit #3 595-730 rev/min	Factory	O	O
	Kit #4 640-805 rev/min	Factory	O	O
	Kit #5 550-675 rev/min	Factory	O	O
	Kit #6 640-805 rev/min	Factory	O	O
	Kit #7 475-600 rev/min	Factory	O	O
	Kit #8 400-525 rev/min	Factory	O	O
	Blower Belt Auto-Tensioner	Factory	O	O
CABINET				
Combination Coil/Hail Guards	C1GARD52D-1	13T16	X	X
Grille Guards	C1GARD39D-1-	86K30	X	X
Horizontal Return Air Panel Kit		38K48	X	X
CONTROLS				
Blower Proving Switch	C1SNSR35FF1	21Z10	OX	OX
	Prodigy® Control System - BACnet® Module - C0CTRL60AE1L	59W51	OX	OX
	Prodigy® Control System - LonTalk® Module - C0CTRL65FF1	54W27	OX	OX
	Novar® LSE	Factory	O	O
Dirty Filter Switch	E1SNSR55C-1	53W68	OX	OX
Discharge Air Temperature Sensor		Factory	O	O
Fresh Air Tempering	C1SNSR75AD1	21Z08	OX	OX
Smoke Detector - Supply or Return (Power board and one sensor)	C1SNSR44C-1	83W40	OX	OX
Smoke Detector - Supply and Return (Power board and two sensors)	C1SNSR43C-1	83W41	OX	OX
Supply Static Limit Switch	C0SNSR11AE1	79M80	X	X
Supply Static Limit Switch - Mounting Kit	C0SNSR12AE1	79M81	X	X
Supply Static Transducer	C0SNSR20AE1	78M19	X	X

NOTE - Catalog and model numbers shown are for ordering field installed accessories.

OX - Configure To Order (Factory Installed) or Field Installed

O = Configure To Order (Factory Installed)

X = Field Installed

OUTDOOR SOUND DATA

Unit Model Number	Octave Band Sound Power Levels dBA, re 10 ⁻¹² Watts Center Frequency - HZ							1 Sound Rating Number (dBA)
	125	250	500	1000	2000	4000	8000	
300/360	84	85	90	90	85	80	72	95

Note - The octave sound power data does not include tonal corrections.

¹ Sound Rating Number according to AHRI Standard 370-2001.

WEIGHT DATA

UNIT

Model Number	Net		Shipping	
	kg	lbs.	kg	lbs.
300 Base Unit	1359	2997	1455	3207
300 Max. Unit	1546	3409	1642	3619
360 Base Unit	1359	2997	1455	3207
360 Max. Unit	1546	3409	1642	3619

WEIGHT DATA

OPTIONS / ACCESSORIES

Description	Shipping Weight	
	kg	lbs.
ECONOMIZER / OUTDOOR AIR / EXHAUST		
Economizer	54	119
Barometric Relief		
Downflow Barometric Relief Dampers	20	45
Horizontal Barometric Relief Dampers	9	20
Outdoor Air Dampers		
Damper Section (downflow) Motorized	33	72
Damper Section (downflow) Manual	31	68
Outdoor Air Hood (downflow)	34	76
POWER EXHAUST		
	45	99
ELECTRIC HEAT		
23 kW	27	59
34.5 kW	34	76
45.9 kW	34	76
68.9 kW	38	84
91.9 kW	44	98
ROOF CURBS		
Hybrid Roof Curbs, Downflow		
356 mm height	52	115
457 mm height	64	140
610 mm height	77	170
Standard Curbs, Horizontal		
356 mm height	202	445
610 mm height	329	725
CEILING DIFFUSERS		
Step-Down LARTD30/36S	625	283
Flush LAFD30/36S	625	283
Transitions LASRT30/36	39	85
PACKAGING		
LTL Packaging (less than truck load)	136	300

OPTIONS / ACCESSORIES

Item Description	Model Number	Catalog Number	Unit Model No	
			300	360
INDOOR AIR QUALITY				
Air Filters				
Healthy Climate High Efficiency Air Filters 508 x 508 x 51 mm - order 12 per unit	MERV 8 - C1FLTR15D-1-	54W21	OX	OX
	MERV 13 - C1FLTR40D-1-	52W39	OX	OX
Replaceable Media Filter with Metal Mesh Frame (includes Non-Pleated Filter Media) 508 x 508 x 51 mm - order 12 per unit	C1FLTR30D-1-	44N60	X	X
Indoor Air Quality (CO₂) Sensors				
Sensor - Wall-mount, off-white plastic cover with LCD display	C0SNSR50AE1L	77N39	X	X
Sensor - Wall-mount, off-white plastic cover, no display	C0SNSR52AE1L	87N53	X	X
Sensor - Black plastic case with LCD display, rated for plenum mounting	C0SNSR51AE1L	87N52	X	X
Sensor - Wall-mount, black plastic case, no display, rated for plenum mounting	C0MISC19AE1	87N54	X	X
CO ₂ Sensor Duct Mounting Kit - for downflow applications	C0MISC19AE1-	85L43	X	X
Aspiration Box - for duct mounting non-plenum rated CO ₂ sensors (87N53 or 77N39)	C0MISC16AE1-	90N43	X	X
ELECTRICAL				
Voltage 50 hz with neutral	380/420V - 3 phase	Factory	O	O
ELECTRIC HEAT				
23 kW	380/420V-3ph - C1EH0230C21M	67W98	OX	OX
34.5 kW	380/420V-3ph - C1EH0345C21M	68W00	OX	OX
45.9 kW	380/420V-3ph - C1EH0459C21M	68W02	OX	OX
68.9 kW	380/420V-3ph - C1EH0689C-1M	68W03	OX	OX
91.9 kW	380/420V-3ph - E1EH0900D-1M	74W01	OX	OX
ECONOMIZER				
High Performance Economizer				
High Performance Economizer Downflow or Horizontal Applications - Includes Outdoor Air Hood. Order Downflow or Horizontal Barometric Relief Dampers separately.	E1ECON17D-2	18X87	OX	OX
Economizer Controls				
Differential Enthalpy	Order 2 - C1SNSR64FF1	21Z09	OX	OX
Sensible Control	Sensor is Furnished	Factory	O	O
Single Enthalpy	C1SNSR64FF1	21Z09	OX	OX
Global, Enthalpy	Sensor Field Provided	Factory	O	O
Differential Sensible	Sensor is Furnished	Factory	O	O
Barometric Relief Dampers With Exhaust Hood				
Downflow Barometric Relief Dampers	E1DAMP60D-1	76W17	OX	OX
Horizontal Barometric Relief Dampers	LAGEDH30/36	33K78	OX	OX
OUTDOOR AIR				
Outdoor Air Dampers With Outdoor Air Hood				
Motorized	E1DAMP25D-2-	18X89	OX	OX
Manual	E1DAMP15D-2-	18X88	OX	OX

NOTE - Catalog and model numbers shown are for ordering field installed accessories.

OX - Configure To Order (Factory Installed) or Field Installed

O = Configure To Order (Factory Installed)

X = Field Installed

OPTIONS / ACCESSORIES

Item Description	Model Number	Catalog Number	Unit Model No	
			300	360
POWER EXHAUST				
Standard Static	380/420V - E1PWRE40D-1M	74W24	OX	OX
ROOF CURBS				
Hybrid Roof Curbs, Downflow				
356 mm height	C1CURB71D-1	11F62	X	X
457 mm height	C1CURB72D-1	11F63	X	X
610 mm height	C1CURB73D-1	11F64	X	X
Standard Roof Curbs, Horizontal - Requires Horizontal Air Panel Kit				
762 mm height - slab applications	C1CURB15C-1	11T90	X	X
1041 mm height - rooftop applications	C1CURB17C-1	11T97	X	X
Horizontal Return Air Panel Kit (Required)		38K48	X	X
Insulation Kit For Standard Horizontal Curbs				
	for C1CURB15C-1	73K33	X	X
	for C1CURB17C-1	73K35	X	X
CEILING DIFFUSERS				
Step-Down - Order one	LARTD30/36S	45K74	X	X
Flush - Order one	LAFD30/36S	45K75	X	X
Transitions (Supply and Return) - Order one	LASRT30/36	33K80	X	X

NOTE - Catalog and model numbers shown are for ordering field installed accessories.

OX - Configure To Order (Factory Installed) or Field Installed

O = Configure To Order (Factory Installed)

X = Field Installed

SPECIFICATIONS

General Data		Nominal kW (Tons)	88 (25)	105 (30)	
		Model Number	LCH300H4B	LCH360H4B	
		Efficiency Type	High	High	
		Blower Type	Constant Air Volume (CAV)	Constant Air Volume (CAV)	
Cooling Performance	Gross Cooling Capacity - kW (Btuh)		76.8 (262 000)	92.0 (314 000)	
	¹ Net Cooling Capacity - kW (Btuh)		74.4 (254 000)	88.5 (302 000)	
	AHRI Rated Air Flow - L/s (cfm)		3825 (8100)	4530 (9600)	
	Total Unit Power - kW		21.1	27.5	
	¹ EER (Btuh/Watt) at 35°C (95°F)		12.0	11.0	
	² EER (Btuh/Watt) at 46°C (115°F)		8.6	8.6	
	¹ IEER (Btuh/Watt)		12.5	11.5	
	Refrigerant Type		R-410A	R-410A	
	Refrigerant Charge	Circuit 1		4.2 kg (9 lbs. 4 oz.)	4.1 kg (9 lbs. 0 oz.)
		Circuit 2		4.1 kg (9 lbs. 0 oz.)	3.6 kg (8 lbs. 0 oz.)
Circuit 3			4.0 kg (8 lbs. 12 oz.)	4.1 kg (9 lbs. 0 oz.)	
Circuit 4			3.9 kg (8 lbs. 8 oz.)	3.4 kg (7 lbs. 8 oz.)	
Electric Heat Available - See page 19					
Compressor Type (number)			Scroll (4)	Scroll (4)	
Outdoor Coils	Net face area - m ² (sq. ft.) total		6.3 (68.3)	6.3 (68.3)	
	Number of rows		1	1	
	Fins per m (Fins per inch)		906 (23)	906 (23)	
Outdoor Coil Fans	Motor - (No.) W (hp)		(6) 249 (1/3)	(6) 249 (1/3)	
	Motor rev/min		900	900	
	Total Motor watts		1775	1775	
	Diameter - mm (in.)		(6) 610 (24)	(6) 610 (24)	
	Number of blades		3	3	
	Total Air volume - L/s (cfm)		8450 (17 900)	8450 (17 900)	
Indoor Coils	Net face area - m ² (sq. ft.) total		2.9 (31.40)	2.9 (31.40)	
	Tube diameter - mm (in.)		9.5 (3/8)	9.5 (3/8)	
	Number of rows		4	4	
	Fins per m (Fins per inch)		551 (14)	(551) 14	
	Drain connection - No. and size		(1) 1 in. NPT	(1) 1 in. NPT	
Expansion device type		Balance port Thermostatic Expansion Valve (TXV), removable head			
³ Indoor Blower and Kit Selection	Nominal motor output	3.7 kW (5 hp) - 5.6 kW (7.5 hp) - 7.5 kW (10 hp)			
	Maximum usable motor output	4.3 kW (5.75 hp) - 6.4 kW (8.63 hp) - 8.6 kW (11.5 hp)			
	Motor - Drive kit	3.7 kW (5 hp)	3.7 kW (5 hp)		
		Kit 5 - 550-675 rev/min	Kit 5 - 550-675 rev/min		
		Kit 6 - 640-805 rev/min	Kit 6 - 640-805 rev/min		
		Kit 7 - 475-600 rev/min	Kit 7 - 475-600 rev/min		
		Kit 8 - 400-525 rev/min			
		5.6 kW (7.5 hp)	5.6 kW (7.5 hp)		
		Kit 3 - 595-730 rev/min	Kit 3 - 595-730 rev/min		
		Kit 4 - 640-805 rev/min	Kit 4 - 640-805 rev/min		
	7.5 kW (10 hp)	7.5 kW (10 hp)			
	Kit 1 - 615-745 rev/min	Kit 1 - 615-745 rev/min			
	Kit 2 - 725-870 rev/min	Kit 2 - 725-870 rev/min			
Blower wheel nominal diameter and width - mm (in.)		(2) 457 x 381 (18 x 15)			
Filters	Type of filter	Fiberglass, disposable			
	Number and size - mm (in.)	(12) 508 x 508 x 51 (20 x 20 x 2)			
Electrical characteristics		380/420V - 50 hertz - 3 phase with neutral (No neutral on CE marked models)			

NOTE - Net capacity includes evaporator blower motor heat deduction. Gross capacity does not include evaporator blower motor heat deduction.

¹ Tested at conditions based on AHRI Standard 340/360; 35°C (95°F) outdoor air temperature and 27°C (80°F) db/19°C (67°F) wb entering evaporator air; minimum external duct static pressure while operating at rated voltage and air volumes.

² Rated at 46°C (115°F) outdoor air temperature and 27°C (80°F) db/19°C (67°F) wb entering evaporator air (T3 Conditions).

³ Using total air volume and system static pressure requirements determine from blower performance tables rev/min and motor output required. Maximum usable output of motors furnished are shown. See Belt Drive Specification Table for maximum usable motor output. If motors of comparable output are used, be sure to keep within the service factor limitations outlined on the motor nameplate.

RATINGS

NOTE – For Temperatures and Capacities not shown in tables, see bulletin – Cooling Unit Rating Table Correction Factor Data in Miscellaneous Engineering Data section.

88 kW - LCH300H4 (1ST STAGE)

Entering Wet Bulb Temperature	Total Air Volume	Outdoor Air Temperature Entering Outdoor Coil																				
		18.3°C						23.9°C					29.4°C					35°C				
		Total Cool Cap.	Comp. Motor Input	Sensible To Total Ratio (S/T)			Total Cool Cap.	Comp. Motor Input	Sensible To Total Ratio (S/T)			Total Cool Cap.	Comp. Motor Input	Sensible To Total Ratio (S/T)			Total Cool Cap.	Comp. Motor Input	Sensible To Total Ratio (S/T)			
				Dry Bulb					Dry Bulb					Dry Bulb					Dry Bulb			
L/s	kW	kW	24°C	27°C	29°C	kW	kW	24°C	27°C	29°C	kW	kW	24°C	27°C	29°C	kW	kW	24°C	27°C	29°C		
17.2°C	3775	43.1	6.21	0.74	0.87	0.99	41.1	6.92	0.74	0.88	1	39	7.72	0.75	0.9	1	36.9	8.63	0.76	0.92	1	
	4720	45.2	6.31	0.79	0.95	1	43.2	7.01	0.79	0.96	1	41.1	7.81	0.81	0.98	1	39	8.73	0.83	1	1	
	5665	47.1	6.4	0.84	1	1	45.3	7.11	0.85	1	1	43.2	7.91	0.87	1	1	41.2	8.83	0.89	1	1	
19.4°C	3775	45.7	6.33	0.58	0.71	0.84	43.7	7.04	0.58	0.72	0.85	41.6	7.83	0.58	0.73	0.87	39.4	8.75	0.58	0.74	0.89	
	4720	47.9	6.43	0.61	0.77	0.92	45.7	7.13	0.62	0.78	0.93	43.5	7.92	0.62	0.79	0.95	41.2	8.83	0.63	0.8	0.97	
	5665	49.4	6.51	0.65	0.82	0.98	47.2	7.2	0.65	0.83	0.99	45	7.99	0.67	0.85	1	42.6	8.89	0.66	0.87	1	
21.7°C	3775	48.8	6.47	0.44	0.57	0.69	46.7	7.18	0.44	0.57	0.7	44.5	7.97	0.43	0.57	0.71	42.2	8.87	0.43	0.57	0.72	
	4720	50.9	6.58	0.45	0.6	0.75	48.7	7.28	0.45	0.61	0.76	46.5	8.06	0.44	0.61	0.77	44	8.97	0.44	0.62	0.78	
	5665	52.4	6.66	0.46	0.64	0.8	50.2	7.35	0.46	0.64	0.82	47.9	8.14	0.46	0.66	0.83	45.3	9.03	0.46	0.66	0.85	

88 kW - LCH300H4 (2ND STAGE)

Entering Wet Bulb Temperature	Total Air Volume	Outdoor Air Temperature Entering Outdoor Coil																				
		26.7°C						35°C					43.3°C					46°C				
		Total Cool Cap.	Comp. Motor Input	Sensible To Total Ratio (S/T)			Total Cool Cap.	Comp. Motor Input	Sensible To Total Ratio (S/T)			Total Cool Cap.	Comp. Motor Input	Sensible To Total Ratio (S/T)			Total Cool Cap.	Comp. Motor Input	Sensible To Total Ratio (S/T)			
				Dry Bulb					Dry Bulb					Dry Bulb					Dry Bulb			
L/s	kW	kW	24°C	27°C	29°C	kW	kW	24°C	27°C	29°C	kW	kW	24°C	27°C	29°C	kW	kW	24°C	27°C	29°C		
17.2°C	3775	77.6	14.59	0.76	0.91	1.00	71.7	17.27	0.77	0.93	1.00	64.9	20.63	0.79	0.97	1.00	62.5	21.88	0.81	0.99	1.00	
	4720	81.6	14.79	0.82	0.98	1.00	75.6	17.46	0.84	1.00	1.00	69.3	20.84	0.87	1.00	1.00	67.6	22.11	0.89	1.00	1.00	
	5665	85.8	14.99	0.87	1.00	1.00	79.9	17.68	0.90	1.00	1.00	73.2	21.02	0.94	1.00	1.00	71.2	22.26	0.96	1.00	1.00	
19.4°C	3775	82.9	14.85	0.59	0.74	0.88	76.7	17.51	0.59	0.75	0.90	69.5	20.84	0.60	0.77	0.93	66.9	22.05	0.61	0.80	0.92	
	4720	86.5	15.03	0.63	0.80	0.96	80.1	17.68	0.63	0.82	0.98	72.7	20.99	0.65	0.85	1.00	69.8	22.20	0.66	0.89	1.00	
	5665	89.4	15.17	0.67	0.86	1.00	82.6	17.80	0.68	0.88	1.00	75.0	21.12	0.70	0.92	1.00	72.2	22.32	0.71	0.96	1.00	
21.7°C	3775	88.3	15.12	0.44	0.58	0.72	81.9	17.77	0.43	0.58	0.73	74.7	21.10	0.42	0.59	0.75	71.9	22.30	0.42	0.60	0.72	
	4720	92.2	15.32	0.45	0.62	0.78	85.4	17.95	0.45	0.63	0.80	77.7	21.26	0.44	0.64	0.83	75.0	22.47	0.44	0.67	0.80	
	5665	94.8	15.46	0.47	0.66	0.84	87.9	18.08	0.47	0.68	0.86	79.9	21.37	0.47	0.69	0.90	77.0	22.58	0.47	0.72	0.87	
Entering Wet Bulb Temperature	Total Air Volume	Outdoor Air Temperature Entering Outdoor Coil																				
		48°C						50°C					51.7°C									
		Total Cool Cap.	Comp. Motor Input	Sensible To Total Ratio (S/T)			Total Cool Cap.	Comp. Motor Input	Sensible To Total Ratio (S/T)			Total Cool Cap.	Comp. Motor Input	Sensible To Total Ratio (S/T)								
				Dry Bulb					Dry Bulb					Dry Bulb								
L/s	kW	kW	24°C	27°C	29°C	kW	kW	24°C	27°C	29°C	kW	kW	24°C	27°C	29°C							
17.2°C	3775	60.4	22.87	0.81	0.99	1.00	58.4	23.89	0.82	1.00	1.00	56.9	24.80	0.83	1.00	1.00						
	4720	65.1	23.09	0.89	1.00	1.00	63.1	24.10	0.91	1.00	1.00	61.5	25.02	0.92	1.00	1.00						
	5665	68.6	23.24	0.97	1.00	1.00	66.6	24.27	0.98	1.00	1.00	64.8	25.16	0.99	1.00	1.00						
19.4°C	3775	64.7	23.05	0.60	0.79	0.96	62.5	24.08	0.61	0.80	0.97	60.6	24.95	0.61	0.81	0.98						
	4720	67.6	23.17	0.65	0.87	1.00	65.3	24.20	0.66	0.89	1.00	63.4	25.10	0.67	0.90	1.00						
	5665	69.8	23.29	0.71	0.95	1.00	67.5	24.31	0.72	0.96	1.00	65.4	25.19	0.73	0.97	1.00						
21.7°C	3775	69.6	23.27	0.41	0.60	0.77	67.2	24.29	0.41	0.60	0.78	65.3	25.20	0.41	0.60	0.78						
	4720	72.4	23.43	0.44	0.65	0.85	69.9	24.42	0.44	0.66	0.86	67.8	25.32	0.44	0.66	0.87						
	5665	74.4	23.54	0.46	0.71	0.93	72.0	24.55	0.46	0.72	0.94	69.8	25.44	0.47	0.73	0.95						

RATINGS

NOTE – For Temperatures and Capacities not shown in tables, see bulletin – Cooling Unit Rating Table Correction Factor Data in Miscellaneous Engineering Data section.

105 kW - LCH360H4 (1ST STAGE)

Entering Wet Bulb Temperature	Total Air Volume	Outdoor Air Temperature Entering Outdoor Coil																			
		18.3°C						23.9°C					29.4°C					35°C			
		Total Cool Cap.	Comp. Motor Input	Sensible To Total Ratio (S/T)			Total Cool Cap.	Comp. Motor Input	Sensible To Total Ratio (S/T)			Total Cool Cap.	Comp. Motor Input	Sensible To Total Ratio (S/T)			Total Cool Cap.	Comp. Motor Input	Sensible To Total Ratio (S/T)		
				Dry Bulb					Dry Bulb					Dry Bulb					Dry Bulb		
L/s	kW	kW	24°C	27°C	29°C	kW	kW	24°C	27°C	29°C	kW	kW	24°C	27°C	29°C	kW	kW	24°C	27°C	29°C	
17.2°C	4455	51.5	8.07	0.73	0.86	0.99	49.2	8.94	0.73	0.88	1	46.9	9.92	0.74	0.89	1	44.6	11.06	0.75	0.91	1
	5569	54	8.2	0.78	0.94	1	51.5	9.06	0.79	0.96	1	49.2	10.04	0.8	0.98	1	46.8	11.18	0.81	0.99	1
	6683	56	8.31	0.83	1	1	53.7	9.18	0.85	1	1	51.5	10.16	0.86	1	1	49.1	11.32	0.88	1	1
19.4°C	4455	54.5	8.23	0.57	0.71	0.83	52.1	9.09	0.58	0.71	0.85	49.7	10.07	0.58	0.72	0.86	47.2	11.21	0.58	0.73	0.88
	5569	56.8	8.35	0.61	0.76	0.91	54.3	9.21	0.61	0.77	0.93	51.8	10.18	0.62	0.78	0.95	49.2	11.32	0.62	0.8	0.96
	6683	58.5	8.44	0.64	0.82	0.98	56	9.3	0.65	0.83	0.99	53.4	10.29	0.65	0.85	1	50.8	11.42	0.66	0.86	1
21.7°C	4455	57.9	8.41	0.44	0.56	0.69	55.4	9.27	0.43	0.57	0.69	52.9	10.25	0.43	0.57	0.7	50.3	11.39	0.42	0.57	0.71
	5569	60.3	8.54	0.45	0.6	0.75	57.6	9.4	0.45	0.6	0.75	55.1	10.38	0.44	0.61	0.76	52.4	11.51	0.44	0.61	0.77
	6683	62	8.64	0.46	0.64	0.8	59.2	9.49	0.46	0.64	0.81	56.6	10.46	0.46	0.64	0.83	53.9	11.6	0.46	0.66	0.84

105 kW - LCH360H4 (2ND STAGE)

Entering Wet Bulb Temperature	Total Air Volume	Outdoor Air Temperature Entering Outdoor Coil																			
		26.7°C						35°C					43.3°C					46°C			
		Total Cool Cap.	Comp. Motor Input	Sensible To Total Ratio (S/T)			Total Cool Cap.	Comp. Motor Input	Sensible To Total Ratio (S/T)			Total Cool Cap.	Comp. Motor Input	Sensible To Total Ratio (S/T)			Total Cool Cap.	Comp. Motor Input	Sensible To Total Ratio (S/T)		
				Dry Bulb					Dry Bulb					Dry Bulb					Dry Bulb		
L/s	kW	kW	24°C	27°C	29°C	kW	kW	24°C	27°C	29°C	kW	kW	24°C	27°C	29°C	kW	kW	24°C	27°C	29°C	
17.2°C	4455	94.0	18.85	0.75	0.90	1.00	86.8	22.11	0.76	0.92	1.00	78.7	26.17	0.78	0.96	1.00	75.9	27.62	0.80	0.99	1.00
	5569	98.4	19.09	0.81	0.97	1.00	91.1	22.35	0.83	1.00	1.00	83.3	26.45	0.86	1.00	1.00	81.2	27.97	0.88	1.00	1.00
	6683	102.7	19.33	0.87	1.00	1.00	95.6	22.63	0.89	1.00	1.00	87.7	26.73	0.93	1.00	1.00	85.2	28.22	0.96	1.00	1.00
19.4°C	4455	99.9	19.17	0.58	0.73	0.87	92.3	22.44	0.58	0.74	0.89	83.8	26.48	0.59	0.76	0.93	80.5	27.92	0.60	0.79	0.92
	5569	104.0	19.41	0.62	0.79	0.95	96.0	22.66	0.63	0.81	0.98	87.2	26.70	0.64	0.84	1.00	83.9	28.15	0.66	0.88	1.00
	6683	107.1	19.58	0.66	0.85	1.00	98.9	22.83	0.67	0.88	1.00	89.7	26.85	0.68	0.91	1.00	86.5	28.32	0.70	0.96	1.00
21.7°C	4455	105.9	19.51	0.43	0.57	0.71	98.0	22.77	0.43	0.57	0.72	89.4	26.84	0.42	0.59	0.74	86.2	28.31	0.42	0.61	0.72
	5569	110.2	19.77	0.45	0.62	0.77	102.0	23.01	0.44	0.62	0.79	92.8	27.05	0.44	0.63	0.82	89.4	28.51	0.44	0.66	0.80
	6683	113.2	19.95	0.46	0.65	0.83	104.8	23.19	0.46	0.67	0.86	95.1	27.22	0.46	0.68	0.89	91.6	28.65	0.47	0.71	0.87
Entering Wet Bulb Temperature	Total Air Volume	Outdoor Air Temperature Entering Outdoor Coil																			
		48°C						50°C					51.7°C								
		Total Cool Cap.	Comp. Motor Input	Sensible To Total Ratio (S/T)			Total Cool Cap.	Comp. Motor Input	Sensible To Total Ratio (S/T)			Total Cool Cap.	Comp. Motor Input	Sensible To Total Ratio (S/T)							
				Dry Bulb					Dry Bulb					Dry Bulb							
L/s	kW	kW	24°C	27°C	29°C	kW	kW	24°C	27°C	29°C	kW	kW	24°C	27°C	29°C						
17.2°C	4455	73.2	28.80	0.80	0.98	1.00	70.7	29.99	0.81	0.99	1.00	68.6	31.08	0.82	1.00	1.00					
	5569	78.2	29.13	0.88	0.1	1.00	75.8	30.34	0.89	1.00	1.00	73.7	31.43	0.91	1.00	1.00					
	6683	82.0	29.38	0.96	1.00	1.00	79.5	30.59	0.97	1.00	1.00	77.2	31.69	0.98	1.00	1.00					
19.4°C	4455	77.9	29.10	0.60	0.78	0.95	75.2	30.30	0.60	0.79	0.97	72.8	31.38	0.60	0.80	0.98					
	5569	81.0	29.32	0.65	0.86	1.00	78.2	30.50	0.65	0.87	1.00	75.9	31.60	0.66	0.89	1.00					
	6683	83.4	29.48	0.70	0.94	1.00	80.5	30.69	0.71	0.95	1.00	78.1	31.76	0.72	0.97	1.00					
21.7°C	4455	83.1	29.45	0.41	0.59	0.76	80.4	30.67	0.41	0.59	0.77	77.9	31.73	0.41	0.60	0.78					
	5569	86.4	29.69	0.44	0.65	0.84	83.3	30.90	0.44	0.65	0.85	80.5	31.93	0.44	0.66	0.87					
	6683	88.5	29.82	0.46	0.70	0.92	85.5	31.03	0.46	0.71	0.94	82.7	32.09	0.46	0.72	0.95					

BLOWER DATA

BLOWER TABLE INCLUDES RESISTANCE FOR BASE UNIT ONLY WITH DRY INDOOR COIL & AIR FILTERS IN PLACE
FOR ALL UNITS ADD:

- 1 - Wet indoor coil air resistance of selected unit.
- 2 - Any factory installed options air resistance (electric heat, economizer, etc.)
- 3 - Any field installed accessories air resistance (electric heat, duct resistance, diffuser, etc.)

Then determine from blower table blower motor output and drive required.

See page 17 for wet coil and option/accessory air resistance data.

See page 17 for factory installed drive kit specifications.

MINIMUM AIR VOLUME REQUIRED FOR USE WITH OPTIONAL ELECTRIC HEAT

All units require 4955 L/s (10 500 cfm) minimum air with electric heat.

Air Volume		TOTAL STATIC PRESSURE - Pa (Inches Water Gauge)																	
		100 (0.40)			150 (0.60)			200 (0.80)			250 (1.00)			300 (1.20)			350 (1.40)		
L/s	cfm	rev/min	kW	BHP	rev/min	kW	BHP	rev/min	kW	BHP	rev/min	kW	BHP	rev/min	kW	BHP	rev/min	kW	BHP
1890	4000	433	0.49	0.66	497	0.74	0.99	565	0.95	1.27	630	1.15	1.54	687	1.33	1.78	738	1.52	2.04
2125	4500	441	0.59	0.79	506	0.83	1.11	574	1.05	1.41	638	1.26	1.69	694	1.45	1.94	744	1.65	2.21
2360	5000	451	0.7	0.94	516	0.93	1.25	584	1.16	1.55	646	1.38	1.85	702	1.58	2.12	751	1.79	2.40
2595	5500	462	0.81	1.09	527	1.04	1.39	594	1.28	1.72	655	1.51	2.02	710	1.72	2.31	758	1.95	2.61
2830	6000	473	0.93	1.25	539	1.16	1.55	605	1.42	1.90	665	1.65	2.21	718	1.87	2.51	766	2.11	2.83
3070	6500	486	1.06	1.42	551	1.3	1.74	616	1.56	2.09	675	1.8	2.41	727	2.04	2.73	774	2.29	3.07
3300	7000	499	1.19	1.60	565	1.44	1.93	628	1.73	2.32	685	1.97	2.64	737	2.22	2.98	782	2.49	3.34
3540	7500	513	1.34	1.80	579	1.6	2.14	641	1.9	2.55	696	2.15	2.88	747	2.42	3.24	792	2.71	3.63
3775	8000	528	1.49	2.00	593	1.78	2.39	653	2.1	2.82	708	2.35	3.15	757	2.63	3.53	801	2.95	3.95
4010	8500	544	1.66	2.23	608	1.98	2.65	667	2.31	3.10	720	2.57	3.45	768	2.87	3.85	812	3.21	4.30
4245	9000	561	1.85	2.48	624	2.2	2.95	681	2.54	3.40	733	2.8	3.75	780	3.13	4.20	823	3.5	4.69
4480	9500	578	2.05	2.75	640	2.44	3.27	696	2.78	3.73	746	3.06	4.10	792	3.42	4.58	834	3.81	5.11
4720	10 000	596	2.28	3.06	657	2.69	3.61	711	3.04	4.08	760	3.34	4.48	805	3.73	5.00	845	4.15	5.56
4955	10 500	615	2.53	3.39	674	2.95	3.95	727	3.31	4.44	775	3.65	4.89	817	4.07	5.46	857	4.52	6.06
5190	11 000	634	2.79	3.74	692	3.22	4.32	744	3.61	4.84	789	3.99	5.35	830	4.44	5.95	869	4.91	6.58
5425	11 500	653	3.07	4.12	711	3.51	4.71	760	3.93	5.27	803	4.36	5.84	843	4.84	6.49	881	5.32	7.13
5660	12 000	674	3.38	4.53	729	3.83	5.13	776	4.29	5.75	818	4.77	6.39	857	5.27	7.06	894	5.75	7.71
5900	12 500	695	3.72	4.99	748	4.2	5.63	792	4.69	6.29	832	5.21	6.98	870	5.72	7.67	906	6.21	8.32
6130	13 000	715	4.1	5.50	766	4.61	6.18	808	5.14	6.89	847	5.68	7.61	883	6.21	8.32	918	6.7	8.98
6370	13 500	736	4.52	6.06	784	5.06	6.78	824	5.62	7.53	861	6.18	8.28	896	6.72	9.01	930	7.21	9.66
6605	14 000	757	4.98	6.68	801	5.55	7.44	839	6.14	8.23	875	6.71	8.99	909	7.25	9.72	943	7.74	10.38
6840	14 500	777	5.48	7.35	818	6.08	8.15	854	6.69	8.97	889	7.27	9.75	922	7.81	10.47	955	8.3	11.13
7075	15 000	797	6.02	8.07	834	6.66	8.93	868	7.28	9.76	902	7.86	10.54	935	8.4	11.26	---	---	---

CONTINUED ON NEXT PAGE

BLOWER DATA

BLOWER TABLE INCLUDES RESISTANCE FOR BASE UNIT ONLY WITH DRY INDOOR COIL & AIR FILTERS IN PLACE
FOR ALL UNITS ADD:

- 1 - Wet indoor coil air resistance of selected unit.
- 2 - Any factory installed options air resistance (electric heat, economizer, etc.)
- 3 - Any field installed accessories air resistance (electric heat, duct resistance, diffuser, etc.)

Then determine from blower table blower motor output and drive required.

See page 17 for wet coil and option/accessory air resistance data.

See page 17 for factory installed drive kit specifications.

MINIMUM AIR VOLUME REQUIRED FOR USE WITH OPTIONAL ELECTRIC HEAT

All units require 4955 L/s (10 500 cfm) minimum air with electric heat.

Air Volume		TOTAL STATIC PRESSURE - Pa (Inches Water Gauge)																	
		400 (1.60)			450 (1.80)			500 (2.00)			550 (2.20)			600 (2.40)			650 (2.60)		
L/s	cfm	rev/min	kW	BHP	rev/min	kW	BHP	rev/min	kW	BHP	rev/min	kW	BHP	rev/min	kW	BHP	rev/min	kW	BHP
1890	4000	784	1.72	2.31	824	1.91	2.56	861	2.1	2.82	897	2.31	3.10	932	2.54	3.40	---	---	---
2125	4500	790	1.86	2.49	831	2.07	2.77	868	2.28	3.06	903	2.5	3.35	938	2.73	3.66	974	2.99	4.01
2360	5000	796	2.01	2.69	837	2.24	3.00	874	2.46	3.30	909	2.69	3.61	944	2.94	3.94	980	3.21	4.30
2595	5500	802	2.18	2.92	843	2.42	3.24	880	2.66	3.57	916	2.9	3.89	951	3.15	4.22	987	3.43	4.60
2830	6000	809	2.36	3.16	850	2.62	3.51	887	2.87	3.85	922	3.12	4.18	957	3.38	4.53	994	3.66	4.91
3070	6500	817	2.56	3.43	857	2.83	3.79	894	3.1	4.16	929	3.35	4.49	964	3.62	4.85	1001	3.91	5.24
3300	7000	825	2.78	3.73	864	3.07	4.12	901	3.34	4.48	937	3.6	4.83	971	3.87	5.19	1008	4.17	5.59
3540	7500	833	3.02	4.05	872	3.32	4.45	909	3.61	4.84	945	3.88	5.20	979	4.15	5.56	1016	4.45	5.97
3775	8000	843	3.28	4.40	881	3.6	4.83	918	3.89	5.21	953	4.17	5.59	988	4.45	5.97	1025	4.75	6.37
4010	8500	852	3.56	4.77	890	3.89	5.21	927	4.2	5.63	962	4.49	6.02	997	4.77	6.39	1034	5.08	6.81
4245	9000	862	3.87	5.19	900	4.22	5.66	936	4.53	6.07	972	4.82	6.46	1007	5.11	6.85	1044	5.43	7.28
4480	9500	873	4.21	5.64	910	4.56	6.11	946	4.88	6.54	982	5.17	6.93	1018	5.47	7.33	1055	5.8	7.77
4720	10 000	884	4.57	6.13	921	4.93	6.61	957	5.24	7.02	992	5.54	7.43	1028	5.86	7.86	1066	6.2	8.31
4955	10 500	895	4.94	6.62	932	5.31	7.12	967	5.63	7.55	1003	5.93	7.95	1039	6.27	8.40	1077	6.63	8.89
5190	11 000	907	5.34	7.16	943	5.71	7.65	978	6.03	8.08	1013	6.35	8.51	1050	6.7	8.98	1089	7.08	9.49
5425	11 500	918	5.75	7.71	954	6.13	8.22	989	6.46	8.66	1025	6.78	9.09	1062	7.15	9.58	1101	7.55	10.12
5660	12 000	930	6.19	8.30	965	6.57	8.81	1000	6.9	9.25	1036	7.24	9.71	1073	7.62	10.21	1112	8.03	10.76
5900	12 500	941	6.65	8.91	976	7.03	9.42	1011	7.37	9.88	1048	7.72	10.35	1085	8.1	10.86	1124	8.52	11.42
6130	13 000	953	7.13	9.56	988	7.51	10.07	1023	7.85	10.52	1059	8.21	11.01	---	---	---	---	---	---
6370	13 500	965	7.64	10.24	1000	8.01	10.74	1035	8.35	11.19	---	---	---	---	---	---	---	---	---
6605	14 000	977	8.16	10.94	1012	8.53	11.43	---	---	---	---	---	---	---	---	---	---	---	---

BLOWER DATA

FACTORY INSTALLED BELT DRIVE KIT SPECIFICATIONS

Nominal kW	Nominal hp	Maximum kW	Maximum hp	Drive Kit Number	Rev/min Range
3.7	5	4.3	5.75	5	550 - 675
3.7	5	4.3	5.75	6	640 - 805
3.7	5	4.3	5.75	7	475 - 600
3.7	5	4.3	5.75	8	400 - 525
5.6	7.5	6.4	8.63	3	595 - 730
5.6	7.5	6.4	8.63	4	640 - 805
7.5	10	8.6	11.50	1	615 - 745
7.5	10	8.6	11.50	2	725 - 870

NOTE - Using total air volume and system static pressure requirements determine from blower performance tables rev/min and motor output required. Maximum usable output of motors furnished as shown. If motors of comparable output are used, be sure to keep within the service factor limitations outlined on the motor nameplate.

FACTORY INSTALLED OPTIONS/FIELD INSTALLED ACCESSORY AIR RESISTANCE

Air Volume		Wet Indoor Coil		Electric Heat		Economizer		Filters				Horizontal Roof Curb	
								MERV 8		MERV 13			
L/s	cfm	Pa	in. w.g.	Pa	in. w.g.	Pa	in. w.g.	Pa	in. w.g.	Pa	in. w.g.	Pa	in. w.g.
1890	4000	10	0.04	2	0.01	0	0.00	0	0.00	0	0.00	10	0.04
2125	4500	10	0.04	2	0.01	0	0.00	0	0.00	0	0.00	12	0.05
2360	5000	12	0.05	2	0.01	0	0.00	0	0.00	0	0.00	15	0.06
2595	5500	15	0.06	5	0.02	2	0.01	0	0.00	2	0.01	17	0.07
2830	6000	17	0.07	5	0.02	2	0.01	0	0.00	5	0.02	20	0.08
3070	6500	20	0.08	5	0.02	2	0.01	2	0.01	5	0.02	22	0.09
3300	7000	22	0.09	7	0.03	5	0.02	2	0.01	7	0.03	25	0.10
3540	7500	25	0.10	7	0.03	5	0.02	2	0.01	10	0.04	27	0.11
3775	8000	27	0.11	7	0.03	5	0.02	2	0.01	10	0.04	32	0.13
4010	8500	30	0.12	10	0.04	7	0.03	2	0.01	10	0.04	37	0.15
4245	9000	32	0.13	10	0.04	10	0.04	2	0.01	10	0.04	42	0.17
4480	9500	35	0.14	12	0.05	10	0.04	5	0.02	15	0.06	47	0.19
4720	10 000	37	0.15	12	0.05	12	0.05	5	0.02	15	0.06	52	0.21
4955	10 500	40	0.16	15	0.06	15	0.06	5	0.02	15	0.06	60	0.24
5190	11 000	45	0.18	15	0.06	17	0.07	5	0.02	17	0.07	67	0.27
5425	11 500	47	0.19	17	0.07	20	0.08	5	0.02	20	0.08	75	0.30
5660	12 000	50	0.20	17	0.07	25	0.10	5	0.02	20	0.08	82	0.33
5900	12 500	52	0.21	20	0.08	27	0.11	7	0.03	25	0.10	92	0.37
6130	13 000	57	0.23	20	0.08	32	0.13	7	0.03	25	0.10	100	0.40
6370	13 500	60	0.24	22	0.09	35	0.14	7	0.03	27	0.11	110	0.44
6605	14 000	65	0.26	25	0.10	40	0.16	7	0.03	30	0.12	122	0.49
6840	14 500	67	0.27	25	0.10	45	0.18	10	0.04	32	0.13	132	0.53
7075	15 000	72	0.29	27	0.11	52	0.21	10	0.04	32	0.13	144	0.58

BLOWER DATA

CEILING DIFFUSER AIR RESISTANCE

Air Volume		Step-Down Diffuser - LARTD30/36S						Flush Diffuser - LAFD30/36S	
		2 Ends Open		1 Side/2 Ends Open		All Ends & Sides Open		Pa	in. w.g.
L/s	cfm	Pa	in. w.g.	Pa	in. w.g.	Pa	in. w.g.	Pa	in. w.g.
3540	7500	92	0.37	77	0.31	62	0.25	72	0.29
3775	8000	104	0.42	90	0.36	72	0.29	85	0.34
4010	8500	119	0.48	102	0.41	85	0.34	97	0.39
4245	9000	137	0.55	117	0.47	97	0.39	109	0.44
4485	9500	154	0.62	132	0.53	112	0.45	127	0.51
4720	10000	174	0.70	149	0.60	127	0.51	142	0.57
4955	10 500	194	0.78	169	0.68	144	0.58	162	0.65
5190	11 000	216	0.87	190	0.76	162	0.65	179	0.72
5425	11 500	241	0.97	211	0.85	182	0.73	201	0.81
5665	12 000	269	1.08	234	0.94	204	0.82	223	0.90
5900	12 500	296	1.19	259	1.04	226	0.91	246	0.99
6135	13 000	323	1.30	286	1.15	249	1.00	274	1.10
6370	13 500	356	1.43	313	1.26	374	1.10	298	1.20
6605	14 000	388	1.56	343	1.38	298	1.20	326	1.31
6845	14 500	420	1.69	373	1.50	326	1.31	356	1.43
7080	15 000	457	1.84	405	1.63	356	1.43	388	1.56

CEILING DIFFUSER AIR THROW DATA

Air Volume		1 Effective Throw Range			
		Step-Down		Flush	
L/s	cfm	m	ft.	m	ft.
4245	9000	12 - 14	40 - 47	8 - 11	29 - 35
4485	9500	13 - 15	43 - 50	10 - 12	33 - 41
4720	10 000	14 - 16	46 - 54	11 - 14	37 - 46
4955	10 500	15 - 18	50 - 58	13 - 15	42 - 51
4190	11 000	16 - 19	53 - 61	14 - 17	46 - 56
5425	11 500	17 - 20	55 - 64	15 - 19	50 - 61
5665	12 000	18 - 20	58 - 67	16 - 20	54 - 66
5900	12 500	19 - 22	61 - 71	18 - 22	58 - 71
6135	13 000	20 - 23	64 - 74	19 - 23	62 - 75
6370	13 500	20 - 23	67 - 77	20 - 24	66 - 79

¹ Throw is the horizontal or vertical distance an airstream travels on leaving the outlet or diffuser before the maximum velocity is reduced to 15 m (50 ft.) per minute. Four sides open.

POWER EXHAUST FAN PERFORMANCE - STANDARD STATIC

Return Duct Negative Static Pressure		Air Volume Exhausted	
Pa	in. w.g.	L/s	cfm
0	0	6040	12 800
12	0.05	5760	12 200
25	0.10	5430	11 500
37	0.15	5100	10 800
50	0.20	4670	9900
62	0.25	4250	9000
75	0.30	3730	7900
87	0.35	3190	6750
100	0.40	2570	5450
112	0.45	1960	4150
125	0.50	1370	2900

ELECTRICAL/ELECTRIC HEAT DATA

		LCH300H4B			LCH360H4B		
¹ Voltage - 50Hz 3 Phase with neutral		380/420V			380/420V		
Compressor 1	Rated Load Amps	10.6			12.2		
	Locked Rotor Amps	74			101		
Compressor 2	Rated Load Amps	10.6			12.2		
	Locked Rotor Amps	74			101		
Compressor 3	Rated Load Amps	10.6			12.2		
	Locked Rotor Amps	74			101		
Compressor 4	Rated Load Amps	10.6			12.2		
	Locked Rotor Amps	74			101		
Outdoor Fan Motors (6)	Full Load Amps (total)	1.3 (7.8)			1.3 (7.8)		
Standard Power Exhaust (3) 0.25 kW	Full Load Amps (total)	1.3 (3.9)			1.3 (3.9)		
Indoor Blower Motor	kW	3.7	5.6	7.5	3.7	5.6	7.5
	Full Load Amps	8.2	11.7	16.3	8.2	11.7	16.3
² Maximum Overcurrent Protection	Unit Only	70	70	80	80	80	90
	With (3) 0.25 kW Standard Power Exhaust	70	80	90	80	80	90
³ Minimum Circuit Ampacity	Unit Only	62	65	71	68	72	77
	With (3) 0.25 kW Standard Power Exhaust	65	69	75	72	76	81

ELECTRIC HEAT DATA

		Electric Heat Voltage	420V	420V	420V	420V	420V	420V
² Maximum Overcurrent Protection	Unit+ 23 kW		70	70	80	80	80	90
	⁴ Electric Heat 34.5 kW		70	80	80	80	80	90
	45.9 kW		80	80	90	80	80	90
	68.9 kW		110	110	125	110	110	125
	91.9 kW		150	150	150	150	150	150
³ Minimum Circuit Ampacity	Unit+ 23 kW		62	65	71	68	72	77
	⁴ Electric Heat 34.5 kW		70	74	80	70	74	80
	45.9 kW		74	78	84	74	78	84
	68.9 kW		105	110	116	105	110	116
	91.9 kW		137	141	147	137	141	147
² Maximum Overcurrent Protection	Unit+ 23 kW		70	80	90	80	80	90
	⁴ Electric Heat and Standard Power Exhaust (3) 0.25 kW 34.5 kW		80	80	90	80	80	90
	45.9 kW		80	90	90	80	90	90
	68.9 kW		110	125	125	110	125	125
	91.9 kW		150	150	175	150	150	175
³ Minimum Circuit Ampacity	Unit+ 23 kW		65	69	75	72	76	81
	⁴ Electric Heat and Standard Power Exhaust (3) 0.25 kW 34.5 kW		75	79	85	75	79	85
	45.9 kW		79	83	89	79	83	89
	68.9 kW		110	115	120	110	115	120
	91.9 kW		142	146	152	142	146	152

¹ Extremes of operating range are plus and minus 10% of line voltage.

² Heating, Air Conditioning, Refrigeration (HACR) type breaker or fuse.

³ Refer to local electrical code to determine wire, fuse and disconnect size requirements.

⁴ Nominal kW based on 420V-3ph-50hz.

ELECTRIC HEAT CAPACITIES

Volts Input	23 kW			34.5 kW			45.9 kW			68.9 kW			91.9 kW		
	kW Input	Btuh Output	No. of Stages	kW Input	Btuh Output	No. of Stages	kW Input	Btuh Output	No. of Stages	kW Input	Btuh Output	No. of Stages	kW Input	Btuh Output	No. of Stages
380	18.8	64 200	1	28.2	93 600	2	37.6	128 400	2	56.4	192 500	2	75.2	236 700	2
400	20.8	71 100	1	31.2	106 700	2	41.6	142 200	2	62.5	213 200	2	83.4	261 000	2
420	23.0	78 400	1	34.4	117 600	2	45.9	156 800	2	68.9	235 100	2	91.9	313 700	2

UNIT CLEARANCES

Unit With Economizer

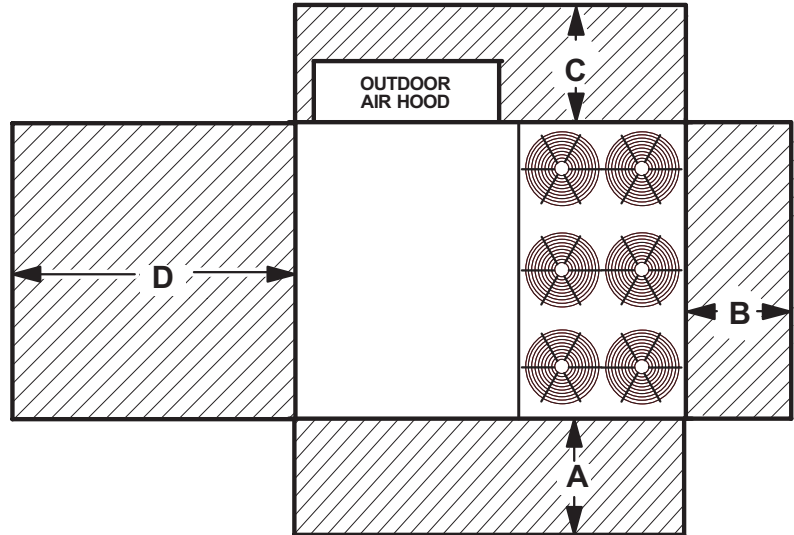

1 Unit Clearance	A		B		C		D		Top Clearance
	mm	in.	mm	in.	mm	in.	mm	in.	
Service Clearance	1524	60	914	36	914	36	1676	66	Unobstructed
Minimum Operation Clearance	1143	45	914	36	914	36	1041	41	

NOTE - Entire perimeter of unit base requires support when elevated above the mounting surface.

¹ **Service Clearance** - Required for removal of serviceable parts.

Minimum Operation Clearance - Required clearance for proper unit operation.

Unit With Horizontal Barometric Relief Dampers

NOTE Allow adequate clearance for duct and barometric relief damper installation.

NOTE Dampers may be installed on each side of return air duct or end to end on one side of return air duct.

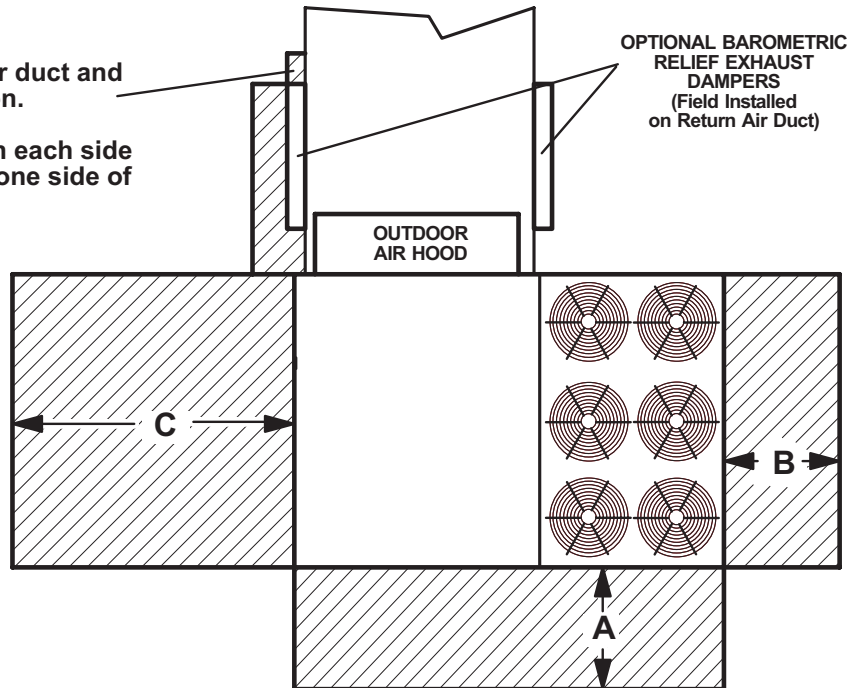

1 Unit Clearance	A		B		C		Top Clearance
	mm	in.	mm	in.	mm	in.	
Service Clearance	1524	60	914	36	1676	66	Unobstructed
Minimum Operation Clearance	1143	45	914	36	1041	41	

NOTE - Entire perimeter of unit base requires support when elevated above the mounting surface.

¹ **Service Clearance** - Required for removal of serviceable parts.

Minimum Operation Clearance - Required clearance for proper unit operation.

DIMENSIONS

UNIT

Model No.	CORNER WEIGHTS								CENTER OF GRAVITY			
	AA		BB		CC		DD		EE		FF	
	kg	lbs.	kg	lbs.	kg	lbs.	kg	lbs.	mm	in.	mm	in.
LCH300 Base Unit	277	610	278	612	399	880	406	895	1524	60	940	37
LCH300 Max. Unit	315	693	316	696	454	1001	462	1018	1524	60	940	37
LCH360 Base Unit	277	610	278	612	399	880	406	895	1524	60	940	37
LCH360 Max. Unit	315	693	316	696	454	1001	462	1018	1524	60	940	37

Base Unit - The unit with NO INTERNAL OPTIONS.

Max. Unit - The unit with ALL INTERNAL OPTIONS Installed. (Economizer, Standard Static Power Exhaust Fans, Controls, etc.). Does not include accessories external to unit or high static power exhaust.

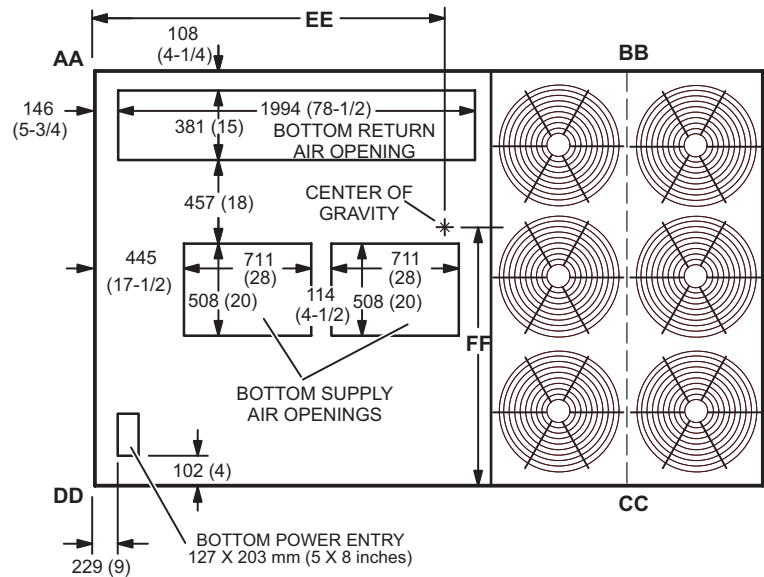

TOP VIEW

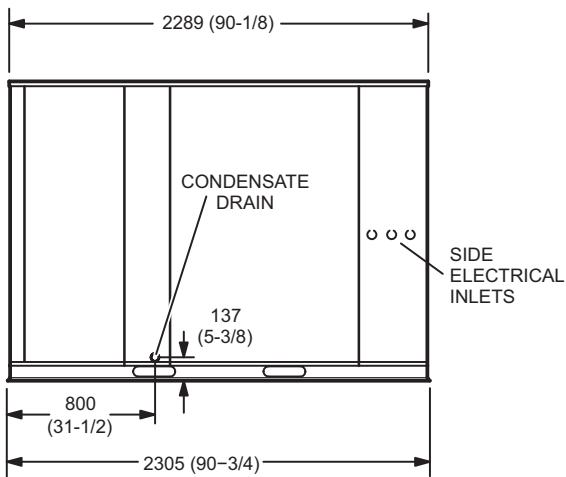

END VIEW

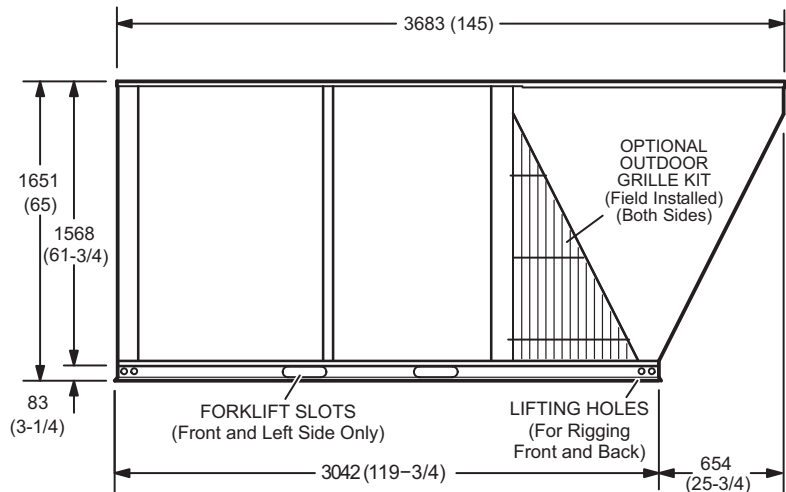

SIDE VIEW

OUTDOOR AIR HOOD DETAIL

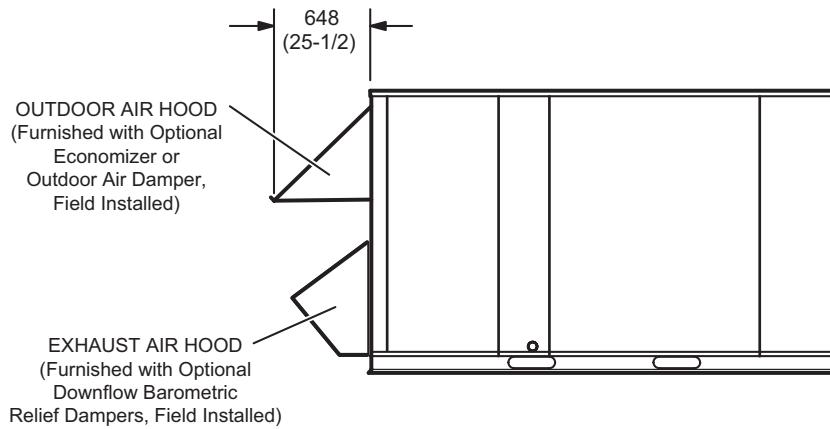

OPTIONAL HORIZONTAL BAROMETRIC RELIEF DAMPERS WITH HOOD

(Field installed in horizontal return air duct adjacent to unit)

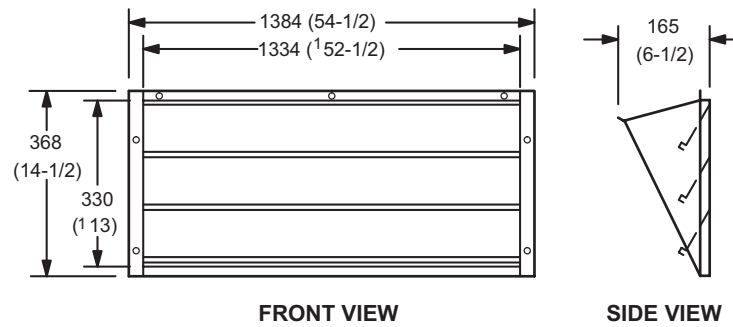

NOTE - Two furnished per order no.

¹ NOTE - Opening size required in return air duct.

HYBRID ROOF CURBS - DOUBLE DUCT OPENING

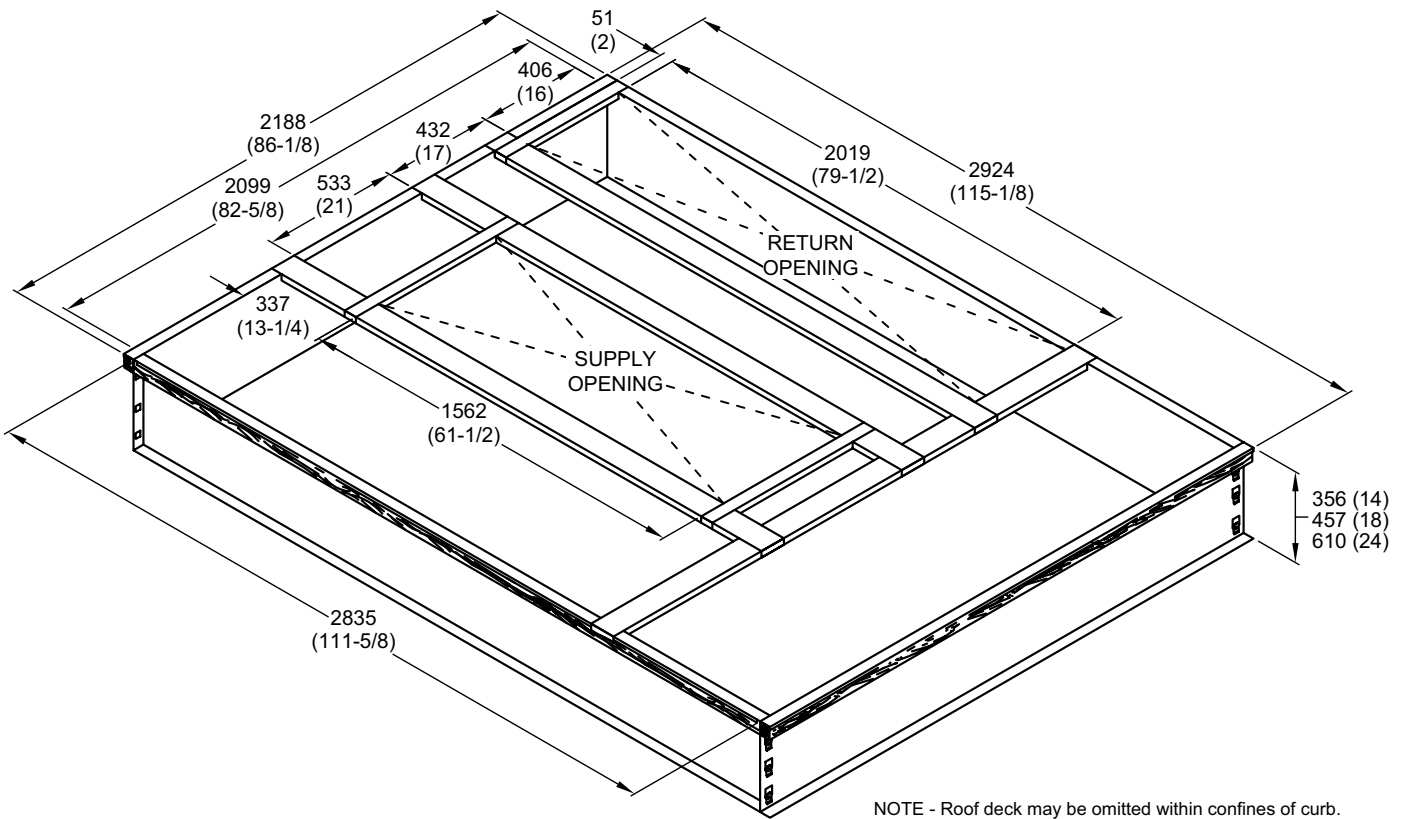

TYPICAL FLASHING DETAIL FOR ROOF CURB

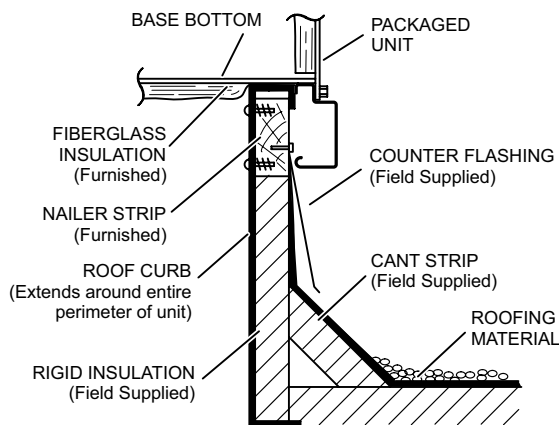

DETAIL ROOF CURB

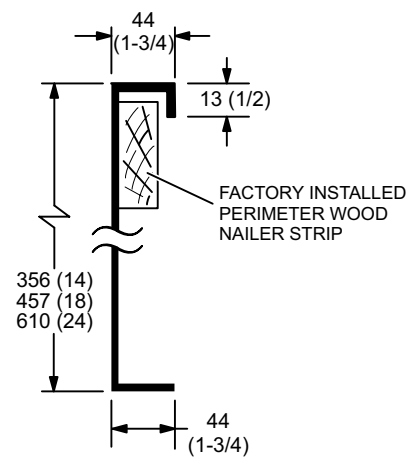

ROOF CURBS WITH SUPPLY & RETURN AIR TRANSITIONS FOR CEILING DIFFUSERS

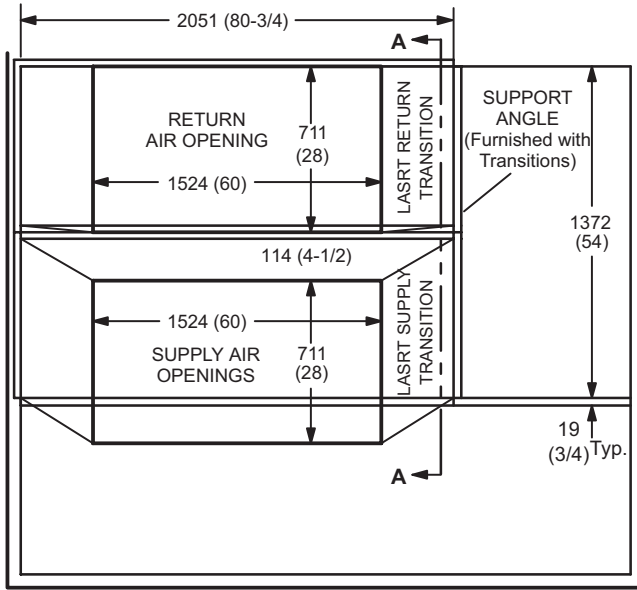

TOP VIEW

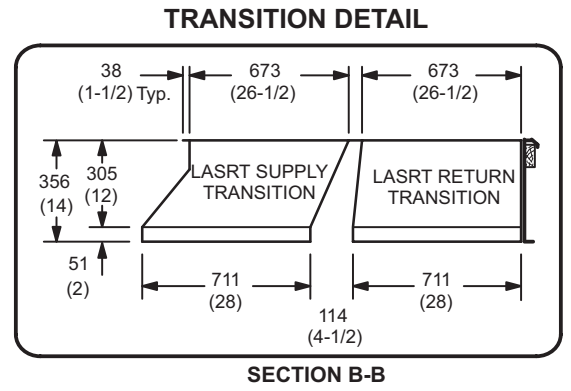

SECTION B-B

HORIZONTAL ROOF CURBS – Requires Optional Horizontal Return Air Panel Kit

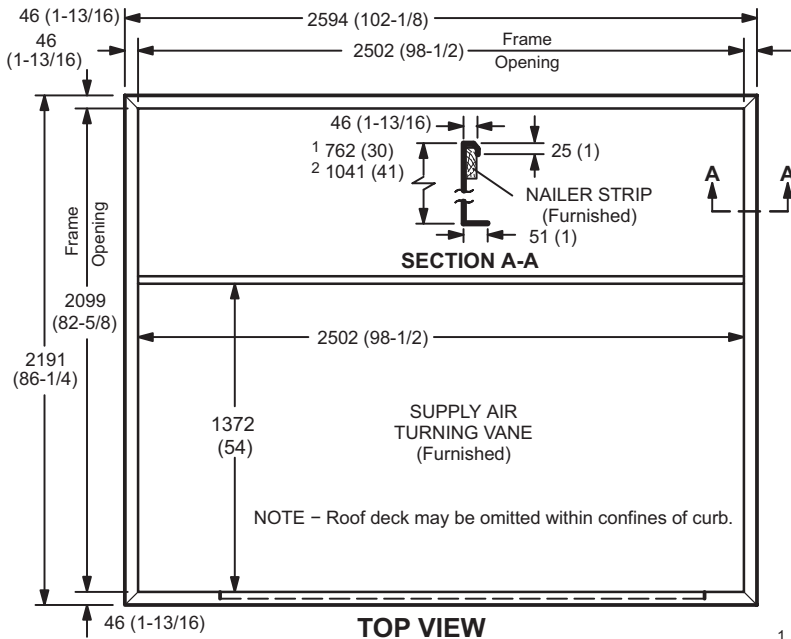

NOTE - 762 mm (30 in.) height Curb is designed for horizontal discharge when unit is mounted on a slab.
1041 mm (41 in.) height Curb is designed for horizontal discharge when unit is mounted on a rooftop.

PANEL TO COVER RETURN AIR OPENING IN BOTTOM OF UNIT (Furnished With Optional Horizontal Return Air Panel Kit)

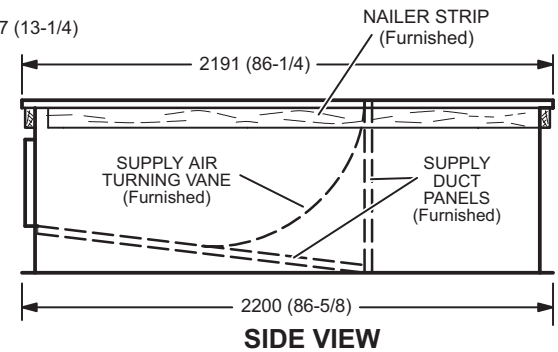
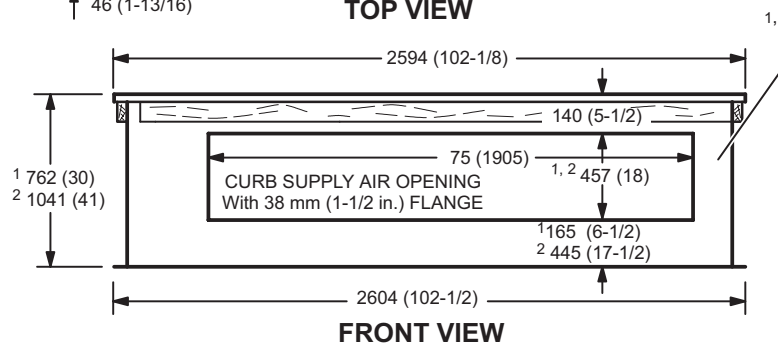
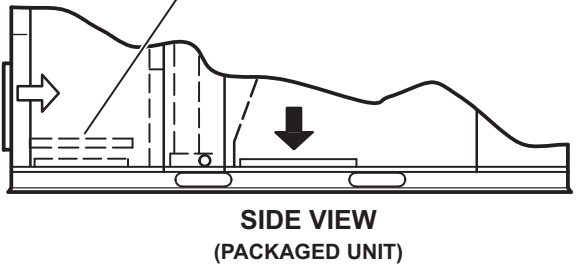

¹ Slab Applications ² Rooftop Applications

**HORIZONTAL SUPPLY AND RETURN AIR OPENINGS
ROOFTOP UNIT WITH HORIZONTAL ROOF CURB**

¹ Slab Applications
² Rooftop Applications

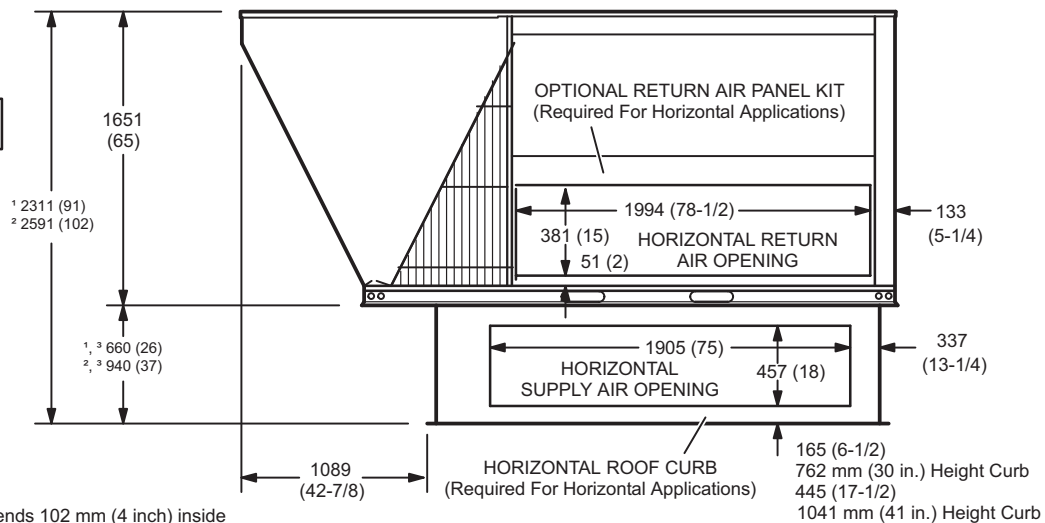

³ NOTE – Top of Curb extends 102 mm (4 inch) inside bottom of unit base. See Typical Flashing Detail.

COMBINATION CEILING SUPPLY AND RETURN DIFFUSERS

STEP-DOWN CEILING DIFFUSER

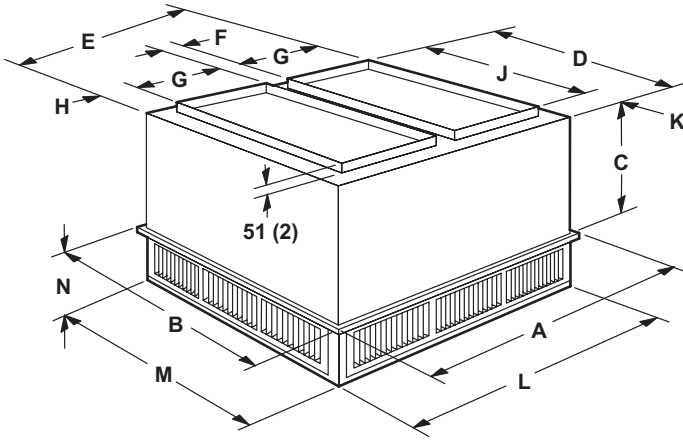

FLUSH CEILING DIFFUSER

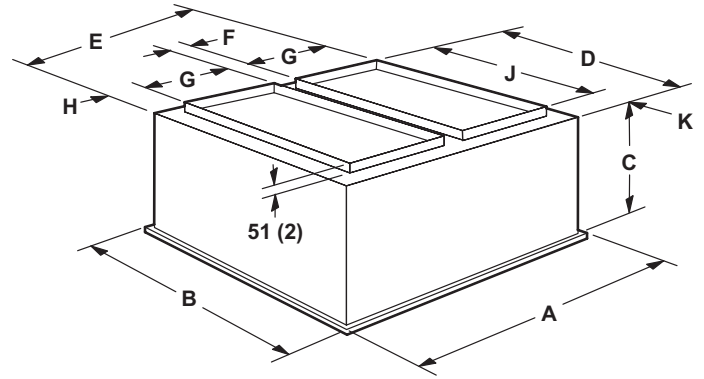

Model Number		LARTD30/36S
A	mm	1667
	in.	65-5/8
B	mm	1667
	in.	65-5/8
C	mm	1029
	in.	40-1/2
D	mm	1613
	in.	63-1/2
E	mm	1613
	in.	63-1/2
F	mm	114
	in.	4-1/2
G	mm	711
	in.	28
H	mm	38
	in.	1-1/2
J	mm	1524
	in.	60
K	mm	44
	in.	1-3/4
L	mm	1613
	in.	63-1/2
M	mm	1613
	in.	63-1/2
N	mm	308
	in.	12-1/8
Duct Size	mm	711 x 1524
	in.	28 x 60

Model Number		LAFD30/36S
A	mm	1667
	in.	65-5/8
B	mm	1667
	in.	65-5/8
C	mm	1016
	in.	40
D	mm	1613
	in.	63-1/2
E	mm	1613
	in.	63-1/2
F	mm	108
	in.	4-1/4
G	mm	711
	in.	28
H	mm	32
	in.	1-5/8
J	mm	1524
	in.	60
K	mm	44
	in.	1-3/4
Duct Size	mm	711 x 1524
	in.	28 x 60

REVISIONS

Sections	Description of Change
Options/Accessories	Catalog numbers revised for: Blower Proving Switch Drain Pan Overflow Switch Fresh Air Tempering Single Enthalpy



Visit us at www.lennox.com

For the latest technical information, www.lennoxcommercial.com

Contact us at 1-800-4-LENNOX

NOTE - Due to Lennox' ongoing commitment to quality, Specifications, Ratings and Dimensions subject to change without notice and without incurring liability. Improper installation, adjustment, alteration, service or maintenance can cause property damage or personal injury. Installation and service must be performed by a qualified installer and servicing agency.

©2021 Lennox Industries, Inc.