

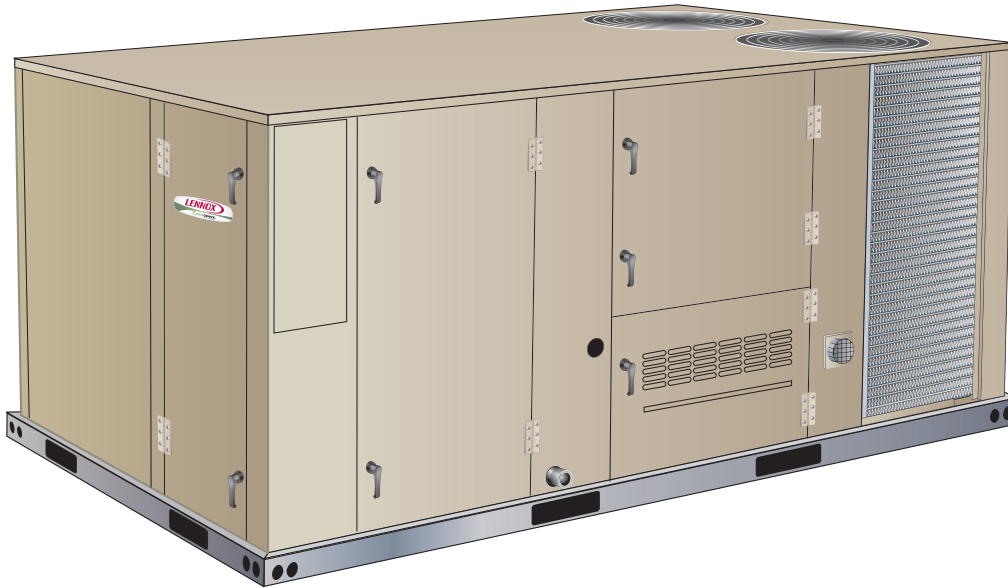

COMMERCIAL
PRODUCT SPECIFICATIONS

Bulletin 490139
 March 2021
 Supersedes February 2020



SMART WIRE™ SYSTEM



26 to 44 kW (7.5 to 12.5 Ton)
Net Cooling Capacity - 23.7 to 36.7 kW (81 000 to 123 300 Btuh)
Gas Input Heat Capacity - 38.1 to 70.3 kW (130 000 to 240 000 Btuh)

MODEL NUMBER IDENTIFICATION

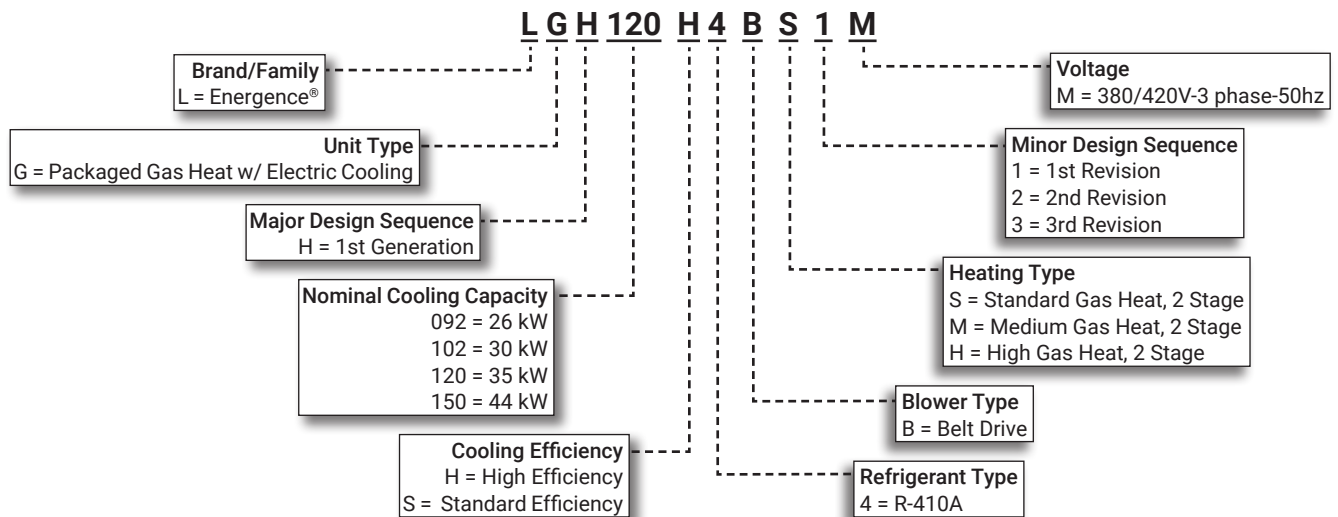

FEATURE HIGHLIGHTS

Lennox' Energence® packaged rooftop unit product line was created to save energy with intelligence by offering some of the highest energy efficiency ratings available with a powerful, easy to use unit controller. This makes Energence rooftop units perfect for business owners looking for an HVAC product with the lowest total cost of ownership.

1. Heat Exchanger/Inshot Burners
2. Scroll Compressors
3. Environ™ Coil System
4. Outdoor Coil Fan Motors
5. Heavy Gauge Steel Cabinet
6. Hinged Access Panels
7. Supply Air Blower
8. Air Filters
9. Prodigy® Control System
10. Economizer (option)
11. Downflow Barometric Relief Dampers (option)

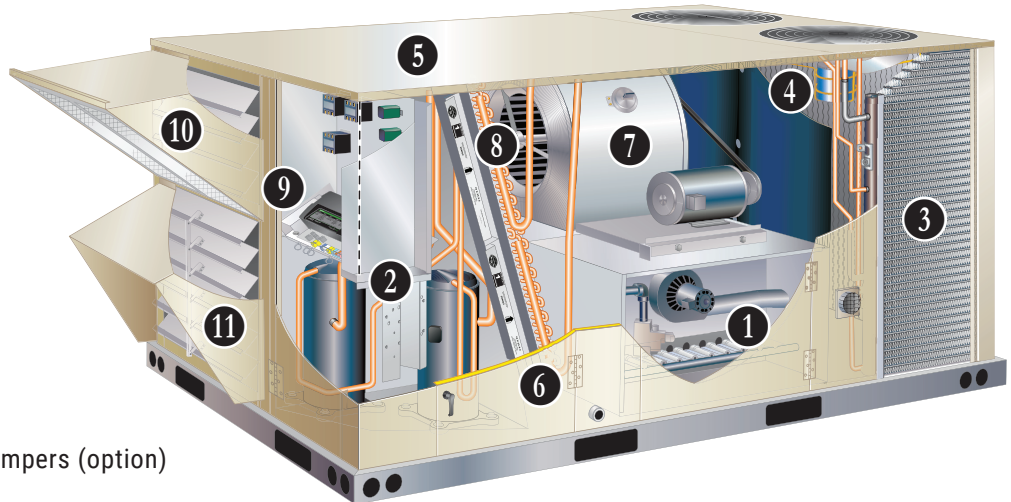

CONTENTS

Blower Data	25
Control System	7
Dehumidification System Option	13
Dehumidification System Ratings	23
Dimensions - Accessories	32
Dimensions - Unit	31
Electrical Data	28
Features And Benefits	3
High Altitude Derate	18
Model Number Identification.	1
Options / Accessories	14
Outdoor Sound Data	29
Performance/Quality And CE Mark Option	3
Ratings	19
Specifications	17
Specifications - Gas Heat	18
Unit Clearances	29
Weight Data	30

PERFORMANCE/QUALITY AND CE MARK OPTION

PERFORMANCE/QUALITY

- Cooling performance is rated at test conditions included in Air-Conditioning, Heating and Refrigeration Institute (AHRI) Standard 340/360 while operating at rated voltage and air volumes
- Components bonded for grounding to meet safety standards for servicing required by Underwriters Laboratories (UL) and the International Electrotechnical Commission (IEC)
- International Organization for Standardization (ISO) 9001 Registered Manufacturing Quality System

CE MARK OPTION

- The CE mark has been added to our rooftop product line as a configure to order (CTO) option
- This optional construction allows units to be sold into countries requiring CE marking for rooftop products
- CE marked units meet the requirements of the Machinery Directive 2006/42/EC, Low Voltage Directive 73/23/EEC, EMC Directive 89/336/EEC, and Gas Directive 90/396/EEC
- Declaration of conformity certificates will be provided for each CE marked unit on demand
- Key features of this option over and above standard product features are:
 - Touch-proof electrical components meeting the requirements of EN 60529
 - Branch circuits over 0.5 kW load have overcurrent protection
 - Rotary style/finger safe disconnect switch with locking handle prevents disconnect door from being opened with the power on
 - Padlock can be applied to lock the disconnect switch in the OFF position
- The factory wiring has been redesigned for separation of high and low voltage circuits



FEATURES AND BENEFITS

HEATING SYSTEM

- 1 • Aluminized steel inshot burners
 - Direct spark ignition
 - Electronic flame sensor
 - Combustion air inducer
 - Redundant automatic dual stage gas valve with manual shut-off

Heat Exchanger

- Tubular construction, aluminized steel
- Life-cycle tested

NOTE - Optional Stainless Steel Heat Exchanger is required if mixed air temperature is below 7°C.

Electronic Pilot Ignition

- Electronic spark igniter provides positive direct ignition of burners on each operating cycle
- Permits main gas valve to stay open only when the burners are proven to be lit
- If loss of flame occurs, gas valve closes, shutting off the gas to the burners
- LED indicates status and aids in troubleshooting
- Watchguard circuit on module automatically resets ignition controls after one hour of continuous thermostat demand after unit lockout, eliminating nuisance service calls
- Factory installed in the gas heating compartment

Limit Controls

- Redundant limit controls with fixed temperature setting
- Protects heat exchanger and other components from overheating

Safety Switches

- Flame roll-out switch
- Flame sensor
- Combustion air inducer proving switch
- Protects system operation

Required Selections

Gas Input Choice - Order one:

- Standard Gas Heat, 2 Stage (24.7/38 kW)
- Medium Gas Heat, 2 Stage (34.2/52.7 kW)
- High Gas Heat, 2 Stage, (45.7/70.3 kW)

Options/Accessories

Factory Installed

Stainless Steel Heat Exchanger

- Required if mixed air temperature is below 7°C

Factory or Field Installed

Bottom Gas Piping Kit

- Allows bottom gas entry
- Factory installed kit is furnished with the unit for field installation

FEATURES AND BENEFITS

HEATING SYSTEM (continued)

Options/Accessories

Combustion Air Intake Extensions

- Recommended for use with existing flue extension kits in areas where high snow areas can block intake air

LPG/Propane Kits

- Conversion kit to field change over units from Natural Gas to LPG/Propane

Vertical Vent Extension Kit

- Use to exhaust flue gases vertically above unit
- Required when unit vent is too close to fresh air intakes per building codes
- Also prevents ice formation on intake louvers
- Kit contains vent transition, vent tee, drain cap and installation hardware

NOTE - Straight vent pipes (102 mm B-Vent) and caps are not furnished and must be field supplied. Refer to kit instructions for additional information.

COOLING SYSTEM

- Designed to maximize sensible and latent cooling performance at design conditions
- System can operate from -18°C to 52°C without any additional controls

R-410A Refrigerant

- Non-chlorine based
- Ozone friendly

2 Scroll Compressors

- Scroll compressors on all models for high performance, reliability and quiet operation
- Resiliently mounted on rubber grommets for quiet operation

Compressor Crankcase Heaters

- Protects against refrigerant migration that can occur during low ambient operation

Thermal Expansion Valves

- Assures optimal performance throughout the application range
- Removable element head

Filter/Driers

- High capacity filter/drier protects the system from dirt and moisture

High Pressure Switches

- Protects the compressors from overload conditions such as dirty condenser coils, blocked refrigerant flow, or loss of outdoor fan operation

Low Pressure Switches

- Protects the compressors from low pressure conditions such as low refrigerant charge, or low/no airflow

Freezestats

- Protects the evaporator coil from damaging ice build-up due to conditions such as low/no airflow, or low refrigerant charge

3 Condenser Coil - Environ™ Coil System (092 through 120 models only)

- Lightweight, all aluminum brazed fin construction
- Constructed of three components
 - A flat extrusion tube
 - Fins in-between the flat extrusion tube
 - Two refrigerant manifolds



Environ™ Coil System Features:

- Improved heat transfer performance due to high primary surface area (flat tubes) versus secondary surface (fins)
- Smaller internal volume (reduced refrigerant charge)
- High durability
- All aluminum construction
- Fewer brazed joints
- Compact design
- Reduced unit weight
- Easy maintenance/cleaning
- Face split design
- Mounting brackets with rubber inserts secure coil to unit providing vibration dampening and corrosion protection

Conventional Fin/Tube Condenser Coils (150 models only, optional 092-120 models)

- Copper tube construction
- Enhanced rippled-edge aluminum fins
- Flared shoulder tubing connections
- Silver soldered construction

Evaporator Coil

- Copper tube construction
- Enhanced rippled-edge aluminum fins
- Flared shoulder tubing connections
- Silver soldered construction
- Factory leak tested
- Cross row circuiting with rifled tubing

Condensate Drain Pan

- Plastic pan, sloped to meet drainage requirements per ASHRAE 62.1
- Side or bottom drain connections
- Reversible to allow connection at back of unit

4 Outdoor Coil Fan Motors

- Thermal overload protected
- Totally enclosed
- Permanently lubricated ball bearings
- Shaft up
- Wire basket mount

NOTE - All 150 models feature two-speed motors for optimal performance at low ambient conditions.

FEATURES AND BENEFITS

COOLING SYSTEM (continued)

Outdoor Coil Fans

- Polyvinyl chloride (PVC) coated fan guard furnished

Required Selections

Cooling Capacity

- Specify nominal cooling capacity

Options/Accessories

Factory Installed

Conventional Fin/Tube Condenser Coil (replaces Environ™ Coil System - 092 through 120 models only)

- Copper tube construction
- Enhanced rippled-edge aluminum fins
- Flared shoulder tubing connections
- Silver soldered construction

NOTE - All 150 models have a fin/tube coil as standard.

Service Valves

- Fully serviceable brass valves installed in discharge & liquid lines

NOTE - Not available for units equipped with Environ™ Coil System or Humiditrol Dehumidification option.

Factory or Field Installed

Condensate Drain Trap

- Available in copper or PVC
- Field installed only, may be factory ordered to ship with unit

Drain Pan Overflow Switch

- Monitors condensate level in drain pan
- Shuts down unit if drain becomes clogged

CABINET

5 Construction

- Heavy-gauge steel panels
- Full perimeter heavy-gauge galvanized steel base rail
- Base rails have rigging holes
- Three sides of the base rail have forklift slots
- Raised edges around duct and power entry openings in the bottom of the unit for water protection

Airflow Choice

- Units are shipped in downflow (vertical) return air flow configuration

NOTE - Units can be field converted to horizontal airflow with optional Horizontal Discharge Kit.

Duct Flanges

- Provided for horizontal duct attachment

Power/Gas Entry

- Electrical and gas lines can be brought through the unit base or through horizontal access knock-outs

Exterior Panels

- Constructed of heavy-gauge, galvanized steel
- Two-layer enamel paint finish

Insulation

- Fully insulated with non-hygroscopic fiberglass insulation (conditioned areas)
- Unit base is fully insulated
- Base insulation serves as an air seal to the roof curb, eliminating the need to add a seal during installation

6 Hinged Access Panels

- Tool-less access
- Filter section
- Blower/heating section
- Compressor/controls section
- Panel seals and quarter-turn latching handles provide a tight air and water seal

Required Selections

Airflow Configuration

- Specify downflow or horizontal

Options/Accessories

Factory or Field Installed

Return Air Adaptor Plate

- For same size LC/LG/LH and TC/TG/TH unit replacement
- Installs on return air opening in unit to match return air opening on existing roof curbs
- Also see Accessory Air Resistance table

Factory Installed

Corrosion Protection

- Completely flexible immersed coating
- Electrodeposited dry film process
- AST ElectroFin E-Coat
- Meets Mil Spec MIL-P-53084, ASTM B117 Standard Method Salt Spray Testing
- Indoor Corrosion Protection:
 - Coated coil
 - Coated reheat coil (Humiditrol®)
 - Painted blower housing
 - Painted base
- Outdoor Corrosion Protection:
 - Coated coil
 - Painted outdoor base

FEATURES AND BENEFITS

CABINET (contined)

Field Installed

Options/Accessories

Combination Coil/Hail Guards

- Heavy gauge steel frame
- Painted to match cabinet
- Expanded metal mesh protects outdoor coil

Horizontal Discharge Kit

- Consists of duct covers to block off downflow supply and return air openings for horizontal applications
- Also includes return air duct flanges for end return air when economizer is used in horizontal applications

NOTE - When configuring unit for horizontal application with economizer, a separate Horizontal Barometric Relief Damper with Hood must be ordered separately for installation in the return air duct

BLOWER

- A wide selection of supply air blower options are available to meet a variety of airflow requirements

Motor

- Overload protected
- Ball bearings
- Belt drive motors are offered on all models and are available in several different sizes to maximize air performance

7 Supply Air Blower

- Forward curved blades
- Double inlet
- Blower wheel statically and dynamically balanced
- Ball bearings
- Adjustable pulley (allows speed change)
- Blower assembly slides out of unit for servicing

Ordering Information

- Specify motor horsepower and drive kit number when base unit is ordered

Options/Accessories

Factory Installed

Blower Belt Auto-Tensioner

- Provides proper tension to belt drive blower belt without the need for regular adjustments
- Maintains airflow and proper performance

ELECTRICAL

SmartWire™ System

- Keyed and color-coded wiring connectors prevent miswiring
- Wire coloring scheme is standardized across all models
- Each connection is intuitively labeled to make troubleshooting and servicing quick and easy

Electrical Plugs

- Positive connection electrical plugs are used to connect common accessories or maintenance parts for easy removal or installation

INDOOR AIR QUALITY

8 Air Filters

- Disposable 51 mm filters furnished as standard

Options / Accessories

Factory or Field Installed

Healthy Climate® High Efficiency Air Filters

- Disposable MERV 8 or MERV 13 (Minimum Efficiency Reporting Value based on ASHRAE 52.2) efficiency 51 mm pleated filters

Field Installed

Healthy Climate® UVC Germicidal Lamps

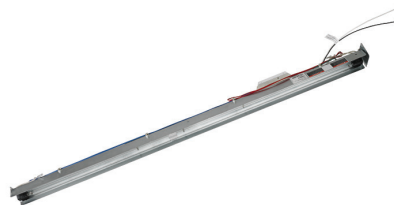

- Germicidal lamps emit ultra-violet (UV-C) energy, which has been proven to be effective in reducing microbes such as viruses, bacteria, yeasts, and molds
- This process either destroys the organism or controls its ability to reproduce
- UV-C energy greatly reduces the growth and proliferation of mold and other bioaerosols (bacteria and viruses) on illuminated surfaces (particularly coil and drain pan)
- Field installed in the blower/evaporator coil section
- Magnetic safety interlock terminates power when access panels are removed
- All necessary hardware for installation is included
- Lamps operate on 220V-1ph power supply

NOTE - Step-down transformer must be field supplied for field installation for 380/420V primary to 220V secondary.

Indoor Air Quality (CO₂) Sensors

- Monitors CO₂ levels, reports to the Prodigy® 2.0 unit controller which adjusts economizer dampers as needed

Replacement Filter Media Kit With Frame

- Replaces existing pleated filter media
- Includes washable metal mesh screen and metal frame with clip for holding replaceable non-pleated filter

CONTROL SYSTEM

PRODIGY® CONTROL SYSTEM



9 The Prodigy 2.0 unit controller is a microprocessor-based controller that provides flexible control of all unit functions.

Features:

- LCD Display
- Easy to read menu (4 lines x 20 character display)
- Buttons for menu navigation during setup and diagnostic
- Menu navigation LEDs for Data, Setup, Service, Settings
- Main Menu and Help Buttons for quick navigation to home screen and built-in help functions
- Scroll, Value Adjustment Select and Save Buttons
- Setup menu insures proper installation and simplified setup of the rooftop unit
- Profile setup copies key settings between units with the same configuration to reduce setup time
- USB port allows a technician to download and transfer unit information to help verify service was performed
- USB software updates on the Prodigy Control System enhance functionality without the need to change components
- Unit Controller Software
- Unit self-test verifies individual critical component and system performance
- Economizer test function assures economizer is operating correctly
- Time Clock with Run-Time Information

Built-In Functions Include:

- Adjustable Blower On/Off Delay
- Built-in Control Parameter Defaults
- Compressor Time-Off Delay
- DDC Compatible
- Dirty Filter Switch Input
- Discharge Air Temperature Control
- Display/Sensor Readout
- Economizer Control Options (See Economizer / Exhaust Air / Outdoor Air sections)
- Fresh Air Tempering
- Over 100 diagnostic and status messages in English
- Exhaust Fan Control Modes for fresh air damper position
- Permanent Diagnostic Code Storage
- Field Adjustable Control Parameters (Over 200 settings)
- Indoor Air Quality Input (Demand Control Ventilation)

- Low Ambient Controls for cooling operation down to 0°F
- Gas Valve Time Delay Between First and Second Stage
- Minimum Compressor Run Time
- Network Capable (Can be daisy chained to other units or controls)
- Night Setback Mode
- Return Air Temperature Limit Control
- Safety Switch Input allows Controller to respond to a external safety switch trip
- Service Relay Output
- Smoke Alarm Mode has four choices (unit off, positive pressure, negative pressure, purge)
- Up to 2 heat/2 cool (standard Prodigy unit controller thermostat input)
- Up to 3 cool with additional relay
- Up to 4 cool with room sensor or network operation
- "Strike Three" Protection
- Gas Reheat Control allows simultaneous heating and cooling operation for humidity control of process air applications such as supermarkets
- On Demand Dehumidification monitors and controls condenser hot gas reheat operation with Humiditrol® dehumidification option
- Thermostat Bounce Delay
- Warm Up Mode Delay
- LED Indicators
- PC Interface connects the Prodigy 2.0 unit controller to a PC with the Lennox Unit Controller Software
- Room Sensor Operation controls temperature

NOTE - Prodigy Control System features shown vary with the type of rooftop unit the control is installed in.

NOTE - See separate Prodigy Control System Product Specifications Bulletin for additional information.

CONTROL SYSTEM

PRODIGY® CONTROL SYSTEM (continued)

Controls Options

Factory or Field Installed

Blower Proving Switch

- Monitors blower operation, shuts down unit if blower fails

Dirty Filter Switch

- Senses static pressure increase indicating dirty filter condition

Fresh Air Tempering

- Used in applications with high outside air requirements
- Controller energizes the first stage heat as needed to maintain a minimum supply air temperature for comfort, regardless of the thermostat demand
- When ordered as a factory option, sensor ships with the unit for field installation

Smoke Detector

- Photoelectric type
- Installed in supply air section, return air section or both sections
- Available with power board and single sensor (supply or return) or power board and two sensors (supply and return)
- Power board located in unit control compartment

Interoperability via BACnet® or LonTalk® Protocols

- Communication compatible with third-party automation systems that support the BACnet Application Specific Controller device profile, LonMark® Space Comfort Controller functional profile, or LonMark Discharge Air Controller functional profile

Commercial Control Systems

After-Market DDC

- Novar® Unit Controller and options

Thermostats

- Control system and thermostat options
- After-Market unit controller options

Field Installed

General Purpose Control Kit

- Plug-in control provides additional analog and digital inputs/outputs for field installed options

Humidity Sensor Kit

- Humidity sensor required with factory installed Humiditrol® dehumidification option or Supermarket reheat field selectable option

OPTIONS / ACCESSORIES

ECONOMIZER

- Economizer operation is set and controlled by the Prodigy 2.0 unit controller
- Simple plug-in connections from economizer to unit controller for easy installation
- All Emergence rooftop units are equipped with factory installed sensors for outside, return and discharge air temperature monitoring

NOTE - Optional sensors may be used instead of unit sensors to determine whether outdoor air is suitable for free cooling. See Options/Accessories table

Factory or Field Installed

10 High Performance Economizer

- Downflow or Horizontal with Outdoor Air Hood
- Outdoor Air Hood is included when economizer is factory installed and is furnished with economizer when ordered for field installation

11 Downflow Barometric Relief Dampers with Exhaust Hood is also furnished

- Gear-driven action
- High torque 24-volt fully-modulating spring return damper motor
- Return air and outdoor air dampers
- Plug-in connections to unit
- Stainless steel bearings
- Enhanced thermoplastic vulcanizate (TPV) blade edge seals
- Flexible stainless steel jamb seals

NOTE - Refer to Installation Instructions for complete setup information.

Differential Sensible Control

- Factory setting
- Uses outdoor air and return air sensors that are furnished with the unit
- The Prodigy® 2.0 unit controller compares outdoor air temperature with return air
- When the outdoor air is below the configured setpoint and cooler than return air, the controller activates the economizer

NOTE - Differential Sensible Control can be configured in the field to provide Offset Differential Sensible Control or Single Sensible Control.

NOTE - In Offset Differential Sensible Control mode, the economizer is enabled if the temperature differential (offset) between outdoor air and return air reaches the configured setpoint. In Single Sensible Control mode, the economizer is enabled when outdoor air temperature falls below the configured setpoint.

OPTIONS / ACCESSORIES

ECONOMIZER (continued)

Global Control

- The unit controller communicates with a DDC system with one global sensor (enthalpy or sensible)
- Determines whether outside air is suitable for free cooling on all units connected to the control system
- Sensor must be field provided

Factory or Field Installed

Single Enthalpy Temperature Control (Not for Title 24)

- Outdoor air enthalpy sensor enables Economizer if the outdoor enthalpy is less than the setpoint of the control

Differential Enthalpy Control (Not for Title 24)

- Order two Single Enthalpy Controls
- One is field installed in the return air section
- One is installed in the outdoor air section
- Allows the economizer control to select between outdoor air or return air, whichever has lower enthalpy

Field Installed

Outdoor Air CFM Control

- Maintains constant outdoor air volume levels on the supply air fan and varying unit airflows
- Velocity sensor located in the rooftop unit outdoor air section, the Prodigy® 2.0 unit controller changes the economizer position to help minimize the effect of supply fan speed changes on outdoor air volume levels
- Setpoint for outdoor air volume is established by field testing

NOTE - Not available with Demand Control Ventilation (CO₂ Sensor) or Building Pressure Control.

Building Pressure Control

- Maintains constant building pressure level
- Includes a static pressure transducer and outdoor static pressure assembly
- Using differential pressure information between the outdoor air and the building air, the Prodigy® 2.0 unit controller changes the economizer position to help maintain a constant building pressure

NOTE - Not available with Demand Control Ventilation (CO₂ Sensor) or Outdoor Air CFM Control.

EXHAUST

Factory or Field Installed

Power Exhaust Fan

- Installs internal to unit for downflow applications only with economizer option
- Provides exhaust air pressure relief
- Interlocked to run when supply air blower is operating,
- Fan runs when outdoor air dampers are 50% open (adjustable)
- Motor is overload protected
- Fan is 508 mm diameter
- Five blades
- One 0.25 kW motor

NOTE - Requires Economizer and Downflow Barometric Relief Dampers

Field Installed

Horizontal Low Profile Barometric Relief Dampers

- For use when unit is configured for horizontal applications requiring an economizer
- Allows relief of excess air
- Aluminum blade dampers prevent blow back and outdoor air infiltration during off cycle
- Field installed in return air duct
- Bird screen and hood furnished

NOTE - Requires Horizontal Discharge Kit

OUTDOOR AIR

Factory or Field Installed

Outdoor Air Damper

- Downflow or Horizontal
- Linked mechanical dampers
- 0 to 25% (fixed) outdoor air adjustable
- Installs in unit
- Includes outdoor air hood
- Automatic model features fully modulating spring return damper motor with plug-in connection
- Manual model features parallel blade, gear-driven dampers with adjustable fixed position

OPTIONS / ACCESSORIES

ROOF CURBS

Field Installed

- Nailer strip furnished (downflow only)
- Mates to unit
- US National Roofing Contractors Approved
- Shipped knocked down

Hybrid Roof Curbs, Downflow

- Interlocking tabs fasten corners together
- No tools required
- Can also be fastened together with furnished hardware
- Available in 203, 356, 457, and 610 mm heights

Adjustable Pitch Curb

- Fully adjustable pitch curbs (19 mm per 300 mm in any direction) provide a level platform for rooftop units allowing flexible installations on roofs with uneven or sloped angles
- Uses interlocking tabs to fasten corners together
- No tools required
- Hardware is furnished to connect upper curb with lower curb
- Available in 356 mm height

Adaptor Curbs (not shown)

- Curbs are regionally sourced
- Dimensions vary based upon the source

NOTE - Contact your local sales representative for a detailed cut sheet with applicable dimensions.

CEILING DIFFUSERS

Field Installed

Ceiling Diffusers (Flush or Step-Down)

- White powder coat finish on diffuser face and grilles
- Insulated UL listed duct liner
- Diffuser box has collars for duct connection
- Step-down diffusers have double deflection blades
- Flush diffusers have fixed blades
- Provisions for suspending
- Internally sealed to prevent recirculation
- Removable return air grille
- Adapts to T-bar ceiling grids or plaster ceilings

Transitions (Supply and Return)

- Used with diffusers
- Installs in roof curb
- Galvanized steel construction
- Flanges furnished for duct connection to diffusers
- Fully insulated

OPTIONAL CONVENTIONAL TEMPERATURE CONTROL SYSTEMS

ComfortSense® 8500 Commercial 7-Day Programmable Thermostat

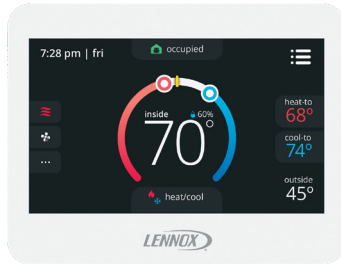

- Fully Communicating Sensor
- Full Color Touchscreen Interface
- Variable Speed System Control (On Compatible Units)
- Up To 4 Heat / 4 Cool
- Built-In Sensors For Temperature, Humidity And Optional CO₂
- Remote Sensor Options For Occupancy, Temperature
- BACnet Capable Options
- 5-2 or 7-Day Scheduling
- Smooth Setback Recovery
- Heat/Cool Auto-Changeover
- Four-Wire Installation
- FDD, ASHRAE, IECC Compliant

ComfortSense® 7500 Commercial 7-Day Programmable Thermostat



- Premium Universal Thermostat
- Full Color Touchscreen Interface
- Up To 4 Heat / 4 Cool
- Built-In Sensors For Temperature and Humidity
- Remote Sensors Options For Temperature, Discharge Air, Outdoor Air
- 5-2 or 7-Day Scheduling
- Smooth Setback Recovery
- Heat/Cool Auto-Changeover
- FDD, ASHRAE, IECC Compliant

ComfortSense® 3000 Commercial 5-2 Day Programmable Thermostat



- Conventional Multi-Stage Thermostat
- Intuitive Display
- Push-Button Operation
- Up To 2 Heat / 2 Cool
- Built-In Temperature Sensor
- Remote Temperature Sensing
- Up to 5-2 Day Scheduling
- Smooth Setback Recovery
- Heat/Cool Auto-changeover

Wired Room Sensor (LCS-5030)



- Simple Push-Button Override
- Variable Speed System Control (On Compatible Units)
- Up To 4 Heat / 4 Cool
- Built-In Temperature and Humidity Sensors
- AA Battery / 24VAC Powered
- SBUS Wired Operation
- Automatic Sensor Averaging
- Locking Hex Screw

OPTIONAL CONVENTIONAL TEMPERATURE CONTROL SYSTEMS

Description	Catalog No.
ComfortSense® 8500 Commercial 7 Day Programmable Thermostat	
CS8500 7-Day Thermostat	No CO ₂ Sensing 17G75
	With CO ₂ Sensing 17G76
Sensors/Accessories	¹ Remote non-adjustable wall-mount 10k 47W37
	¹ Remote non-adjustable wall-mount 11k 94L61
Sysbus Network Cable (Yellow) for ComfortSense 8500 and LCS-5030 Wired Room Sensor	
Twisted pair 100% shielded communication cable, Red and Black	500 ft. box 27M19
22 AWG, yellow jacket, rated at 75°C, 300V, Plenum rated	1000 ft. box 94L63
Insulation - Low smoke PVC, NEC, CMP	2500 ft. roll 68M25
ComfortSense® 7500 Commercial 7-Day Programmable Thermostat	
CS7500 7-Day Thermostat	17G74
Sensors/Accessories	² Remote non-adjustable wall-mount 20k 47W36
	² Remote non-adjustable wall-mount 10k 47W37
	Remote non-adjustable discharge air (duct mount) 19L22
	Outdoor temperature sensor X2658
ComfortSense® 3000 Commercial 5-2 Day Programmable Thermostat	
CS3000 5-2 Day Thermostat	11Y05
Sensors/Accessories	Remote non-adjustable wall mount 10k averaging 47W37
	Thermostat wall mounting plate X2659
ComfortSense® Non-Programmable Thermostat	
CS3000 Non-Programmable Thermostat	51M32
Universal Thermostat Guard with Lock (clear)	
	Inside Dimensions (H x W) 5 7/8 x 8 3/8 in. 39P21
Wired Room Sensor	
LCS-5030 Wired Room Sensor	21L07

¹ Up to nine of the same type remote temperature sensors can be connected in parallel.

² Remote wall-mount sensors can be applied in any of the following combinations:

One Sensor - (1) 47W36, Two Sensors - (2) 47W37, Three Sensors - (2) 47W36 and (1) 47W37

Four Sensors - (4) 47W36, Five Sensors - (3) 47W36 and (2) 47W37

HUMIDITROL® DEHUMIDIFICATION SYSTEM OPTION

OVERVIEW

NOTE - Not available with Environ™ Coil System.
Conventional Fin/Tube condenser coil must be ordered as a factory option.

- Factory installed option designed to control humidity
- Provides dehumidification on demand using ASHRAE 90.1 recommended method for comfort conditioning humidity control
- Unit comes equipped with one row reheat coil, solenoid valve and humidity controller
- A thermostat with a dehumidification output, a dehumidistat, or a DDC controller with an isolated output is required to control humidity and must be located in the occupied space

BENEFITS

- Improves indoor air quality
- Helps prevent damage due to high humidity levels
- Improves comfort levels by reducing space humidity levels

OPERATION

No Dehumidification Demand

- The unit will operate conventionally whenever there is a demand for cooling or heating and no dehumidification demand
- Free cooling is only permitted when there is no demand for dehumidification

Dehumidification Demand Only

- Dehumidification is initiated by an output from a thermostat with a dehumidification output, a dehumidistat, or a DDC controller with an isolated output to control humidity

NOTE - Controls are not furnished and must be ordered separately.

- Reheat operation will initiate on a dehumidification demand and does not require a cooling demand
- The unit will operate in the dehumidification mode until the relative humidity of the conditioned space is below the setpoint
- This reduces sensible cooling capacity and extends compressor run time to control humidity when the cooling load is low
- A solenoid valve diverts hot gas from the compressor to the reheat coil
- The cooled and dehumidified air from the evaporator is reheated as it passes through the reheat coil
- The de-superheated and partially condensed refrigerant continues to the outdoor condenser coil where condensing is completed
- Unit will continue to operate in this mode until the dehumidification demand is satisfied

NOTE - See Sequence of Operation for additional information.

Dehumidification and Cooling Demand (Thermostat/ Room Sensor Application)

- If both a dehumidification and a full cooling load demand occur, the system will operate in cooling until the cooling demand is satisfied
- Then the system will energize the dehumidification mode

Options / Accessories

Humidity Sensor Kit

- Remote mounted dehumidistat for factory installed Humiditrol® option
- Adjustable 20-80%

NOTE - A thermostat with a dehumidification output or a DDC controller with an isolated output can be used instead.

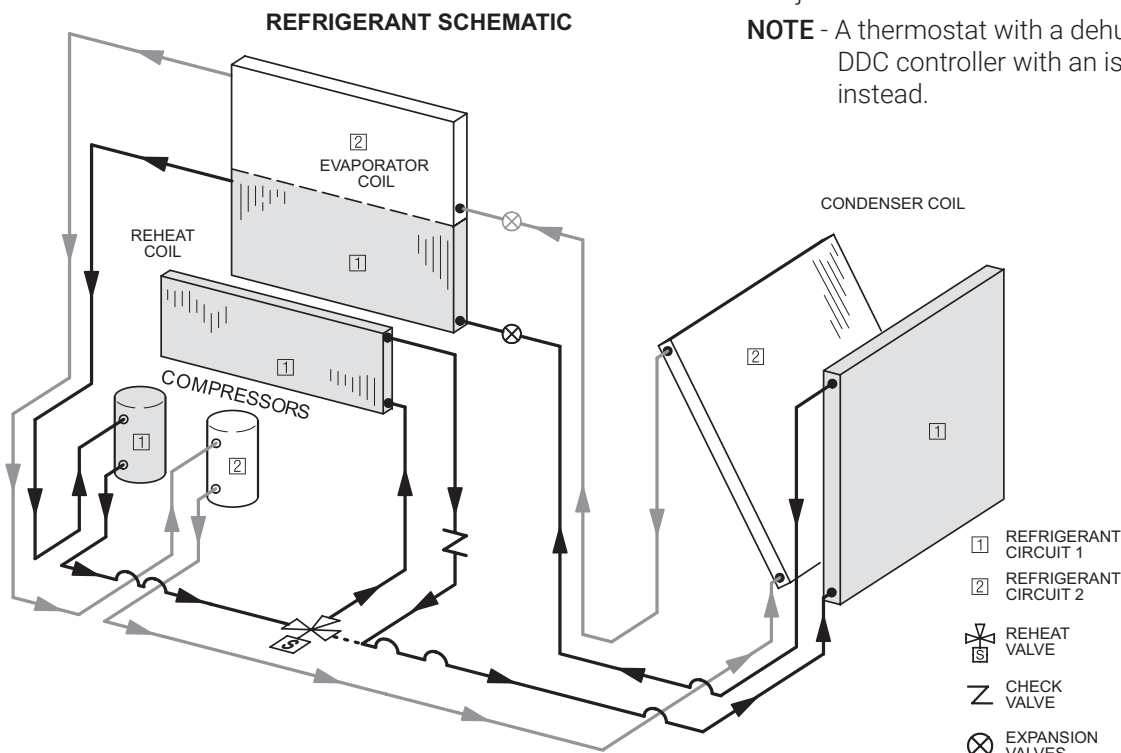

OPTIONS / ACCESSORIES

Item Description	Model Number	Catalog Number	Unit Model No			
			092	102	120	150
CE MARK						
CE Marked Unit		Factory	O	O	O	O
COOLING SYSTEM						
Condensate Drain Trap	Polyvinyl Chloride (PVC) - C1TRAP20AD2	22H54	OX	OX	OX	OX
	Copper - C1TRAP10AD2	76W27	OX	OX	OX	OX
Conventional Fin/Tube Condenser Coil (replaces Environ™ Coil System)		Factory	O	O	O	
Corrosion Protection		Factory	O	O	O	O
Drain Pan Overflow Switch	E1SNSR71AD1	21Z07	OX	OX	OX	OX
Refrigerant Type		R-410A	O	O	O	O
Service valves (not for Environ™ Coil System or Humiditrol® equipped units)		Factory	O	O	O	O
HEATING SYSTEM						
Bottom Gas Piping Kit	C1GPKT01B-01	54W95	OX	OX	OX	OX
Combustion Air Intake Extensions	T1EXTN10AN1	19W51	X	X	X	X
Gas Heat Input	38.1 kW	Factory	O	O	O	O
	52.7 kW	Factory	O	O	O	O
	70.3 kW	Factory	O	O	O	O
LPG/Propane Conversion Kits	Standard Heat - C1PROP23BS1	14N22	X	X	X	X
	Medium Heat - C1PROP22BS1	14N23	X	X	X	X
	High Heat - C1PROP21BS1	14N25	X	X	X	X
Stainless Steel Heat Exchanger		Factory	O	O	O	O
Vertical Vent Extension Kit	C1EXTN2021	42W16	X	X	X	X
BLOWER - SUPPLY AIR						
Motors	Belt Drive - 1.5 kW (2 hp)	Factory	O	O	O	O
	Belt Drive - 2.2 kW (3 hp)	Factory	O	O	O	O
	Belt Drive - 3.7 kW (5 hp)	Factory	O	O	O	O
Drive Kits See Blower Data Tables for selection	Kit #1 490 - 740 rev/min	Factory	O	O	O	O
	Kit #2 665 - 920 rev/min	Factory	O	O	O	O
	Kit #3 660 - 995 rev/min	Factory	O	O	O	O
	Kit #7 610 - 810 rev/min	Factory	O	O	O	O
	Kit #8 780 - 1000 rev/min	Factory	O	O	O	O
	Kit #9 845 - 1085 rev/min	Factory	O	O	O	O
	Kit #10 750 - 945 rev/min	Factory	O	O	O	O
	Kit #11 865 - 1095 rev/min	Factory	O	O	O	O
	Kit #12 940 - 1190 rev/min	Factory	O	O	O	O
	Blower Belt Auto-Tensioner	Factory	O	O	O	O
CABINET						
Combination Coil/Hail Guards	Furnished Environ™ Coil System - C1GARD52B-1	13T05	X	X	X	
	Conventional Fin/Tube Condenser Coil - E1GARD51B-1	13T04	X	X	X	
	Furnished Conventional Fin/Tube Condenser Coil System - C1GARD52B-1	13T05				X
Horizontal Discharge Kit	K1HECK00B-1	51W25	X	X	X	X
Return Air Adaptor Plate (for LC/LG/LH and TC/TG/TH unit replacement)	C1CONV10B-1	54W96	OX	OX	OX	OX

NOTE - Catalog and model numbers shown are for ordering field installed accessories.

OX - Configure To Order (Factory Installed) or Field Installed

O = Configure To Order (Factory Installed)

X = Field Installed

OPTIONS / ACCESSORIES

Item Description	Model Number	Catalog Number	Unit Model No			
			092	102	120	150
CONTROLS						
Blower Proving Switch	C1SNSR35FF1	21Z10	OX	OX	OX	OX
Commercial Controls	Prodigy® Control System - BACnet® Module - C0CTRL60AE1L	59W51	OX	OX	OX	OX
	Prodigy® Control System - LonTalk® Module - C0CTRL65FF1	54W27	OX	OX	OX	OX
	Novar® LSE	Factory	O	O	O	O
Dirty Filter Switch	E1SNSR55B-1	53W67	OX	OX	OX	OX
General Purpose Control Kit	E1GPBK30C1	13J78	X	X	X	X
Fresh Air Tempering	C1SNSR75AD1	21Z08	OX	OX	OX	OX
Smoke Detector - Supply or Return (Power board and one sensor)	C1SNSR44B-2	11K76	OX	OX	OX	OX
Smoke Detector - Supply and Return (Power board and two sensors)	C1SNSR43B-2	11K80	OX	OX	OX	OX
INDOOR AIR QUALITY						
Air Filters						
Healthy Climate® High Efficiency Air Filters 508 x 635 x 51 (Order 4 per unit)	MERV 8 - C1FLTR15B-1	50W61	OX	OX	OX	OX
	MERV 13 - C1FLTR40B-1	52W41	OX	OX	OX	OX
Replacement Media Filter With Metal Mesh Frame (includes non-pleated filter media)	C1FLTR30B-1-	Y3063	X	X	X	X
Indoor Air Quality (CO₂) Sensors						
Sensor - Wall-mount, off-white plastic cover with LCD display	C0SNSR50AE1L	77N39	X	X	X	X
Sensor - Wall-mount, off-white plastic cover, no display	C0SNSR52AE1L	87N53	X	X	X	X
Sensor - Black plastic case with LCD display, rated for plenum mounting	C0SNSR51AE1L	87N52	X	X	X	X
Sensor - Wall-mount, black plastic case, no display, rated for plenum mounting	C0MISC19AE1	87N54	X	X	X	X
CO ₂ Sensor Duct Mounting Kit - for downflow applications	C0MISC19AE1-	85L43	X	X	X	X
Aspiration Box - for duct mounting non-plenum rated CO ₂ sensors (87N53 or 77N39)	C0MISC16AE1-	90N43	X	X	X	X
UVC Germicidal Lamps						
¹ Healthy Climate® UVC Light Kit (220V-1ph)	C1UVCL10B-1	21A93	OX	OX	OX	OX
ELECTRICAL						
Voltage 50 Hz with neutral (No neutral on CE marked models)	380/420V - 3 phase	Factory	O	O	O	O
ECONOMIZER						
High Performance Economizer						
High Performance Economizer Downflow or Horizontal - Includes Outdoor Air Hood and Downflow Barometric Relief Dampers with Exhaust Hood Order Horizontal Barometric Relief Dampers separately	E1ECON17B-3	20U80	OX	OX	OX	OX
Horizontal Barometric Relief Dampers						
Horizontal Low Profile Barometric With Exhaust Hood	LAGEDH03/15	53K04	X	X	X	X
Economizer Controls						
Differential Enthalpy	Order 2 - C1SNSR64FF1	21Z09	OX	OX	OX	OX
Sensible Control	Sensor is Furnished	Factory	O	O	O	O
Single Enthalpy	C1SNSR64FF1	21Z09	OX	OX	OX	OX
Global Control	Sensor Field Provided	Factory	O	O	O	O
Building Pressure Control	E1GPBK20C1	13J77	X	X	X	X
Outdoor Air CFM Control	E1GPBK10C1	13J76	X	X	X	X

¹ Lamps operate on 220V single-phase power supply. Step-down transformer must be field supplied for field installation for 380/420V primary to 220V secondary. Alternately, a separate 220V power supply may be used to directly power the UVC ballast(s).

NOTE - Catalog and model numbers shown are for ordering field installed accessories.

OX - Configure To Order (Factory Installed) or Field Installed

O = Configure To Order (Factory Installed)

X = Field Installed

OPTIONS / ACCESSORIES

Item Description	Model Number	Catalog Number	Unit Model No			
			092	102	120	150
OUTDOOR AIR						
Outdoor Air Dampers With Outdoor Air Hood						
Motorized	C1DAMP20B-1	14G28	OX	OX	OX	OX
Manual	C1DAMP10B-2	14G29	OX	OX	OX	OX
POWER EXHAUST						
Standard Static	380/420V-3ph - K1PWRE10B-1G	53W45	OX	OX	OX	OX
HUMIDITROL® CONDENSER REHEAT OPTION						
Humiditrol Dehumidification Option		Factory	O	O	O	O
Humidity Sensor Kit, Remote mounted (required)	COSNSR31AE-1	17M50	X	X	X	X
ROOF CURBS						
Hybrid Roof Curbs, Downflow						
203 mm height	C1CURB70B-1	11F54	X	X	X	X
356 mm height	C1CURB71B-1	11F55	X	X	X	X
457 mm height	C1CURB72B-1	11F56	X	X	X	X
610 mm height	C1CURB73B-1	11F57	X	X	X	X
Adjustable Pitch Curb, Downflow						
356 mm height	C1CURB55B-1	54W50	X	X	X	X
CEILING DIFFUSERS						
Step-Down - Order one	RTD11-95S	13K61	X			
	RTD11-135S	13K62		X	X	
	RTD11-185S	13K63				X
Flush - Order one	FD11-95S	13K56	X			
	FD11-135S	13K57		X	X	
	FD11-185S	13K58				X
Transitions (Supply and Return) - Order one	C1DIFF30B-1	12X65	X			
	C1DIFF31B-1	12X66		X	X	
	C1DIFF32B-1	12X67				X

NOTE - Catalog and model numbers shown are for ordering field installed accessories.

OX - Configure To Order (Factory Installed) or Field Installed

O = Configure To Order (Factory Installed)

X = Field Installed

SPECIFICATIONS

General Data		Nominal kW (Tons)	26 (7.5)	30 (8.5)	35 (10)	44 (12.5)	
Model Number			LGH092H4B	LGH102H4B	LGH120H4B	LGH150H4B	
Efficiency Type			High	High	High	Standard	
Blower Type			Constant Air Volume CAV	Constant Air Volume CAV	Constant Air Volume CAV	Constant Air Volume CAV	
Cooling Performance	Gross Cooling Capacity - kW (Btuh)		24.6 (84 000)	27.5 (93 900)	32.9 (112 200)	38.1 (130 000)	
	¹ Net Cooling Capacity - kW (Btuh)		23.7 (81 000)	26.4 (90 100)	31.7 (108 200)	36.1 (123 300)	
	AHRI Rated Air Flow - L/s (cfm)		1416 (3000)	1605 (3400)	1700 (3600)	1864 (3950)	
	Total Unit Power - kW		6.4	7.3	8.9	11.0	
	¹ EER (Btuh/Watt) at 35°C (95°F)		12.7	12.4	12.2	11.2	
	² EER (Btuh/Watt) at 46°C (115°F)		8.8	8.5	8.6	7.7	
	³ IEER (Btuh/Watt)		12.9	12.9	12.7	12.4	
Refrigerant Type			R-410A	R-410A	R-410A	R-410A	
Refrigerant Charge	Environ™ Coil System	Circuit 1	2.90 kg (6 lbs. 6 oz.)	2.96 kg (6 lbs. 8 oz.)	3.18 kg (7 lbs. 0 oz.)	---	
		Circuit 2	2.93 kg (6 lbs. 7 oz.)	3.07 kg (6 lbs. 12 oz.)	3.40 kg (6 lbs. 12 oz.)	---	
	Environ™ Coil System With Humiditrol®	Circuit 1	2.90 kg (6 lbs. 6 oz.)	2.96 kg (6 lbs. 8 oz.)	3.18 kg (7 lbs. 0 oz.)	---	
		Circuit 2	2.92 kg (6 lbs. 7 oz.)	3.07 kg (6 lbs. 12 oz.)	3.40 kg (6 lbs. 12 oz.)	---	
	Conventional Fin/Tube Coil Option	Circuit 1	6.12 kg (13 lbs. 8 oz.)	6.12 kg (13 lbs. 8 oz.)	6.58 kg (14 lbs. 8 oz.)	6.35 kg (14 lbs. 0 oz.)	
		Circuit 2	5.68 kg (12 lbs. 8 oz.)	5.68 kg (12 lbs. 8 oz.)	6.12 kg (13 lbs. 8 oz.)	6.12 kg (13 lbs. 8 oz.)	
	Conventional Fin/Tube With Humiditrol®	Circuit 1	7.71 kg (17 lbs. 0 oz.)	7.71 kg (17 lbs. 0 oz.)	7.94 kg (17 lbs. 8 oz.)	6.52 kg (14 lbs. 6 oz.)	
	Circuit 2	5.68 kg (12 lbs. 8 oz.)	5.68 kg (12 lbs. 8 oz.)	6.12 kg (13 lbs. 8 oz.)	6.12 kg (13 lbs. 8 oz.)		
Gas Heating Options Available - See page 18			Standard (2 stage), Medium (2 Stage), High (2 Stage)				
Compressor Type (number)			Scroll (2)	Scroll (2)	Scroll (2)	Scroll (2)	
Outdoor Coil (Fin/Tube)	Net face area (total) - m ² (sq. ft.)		2.60 (28.0) / 2.72 (29.33)	2.60 (28.0) / 2.72 (29.33)	2.60 (28.0) / 2.72 (29.33)	--- (2.6 (28.0))	
		Number of rows	1 (3)	1 (3)	1 (3)	--- (3)	
	Fins per m (Fins per inch)		787 (20)	787 (20)	787 (20)	787 (20)	
Outdoor Coil Fans	Motor - (No.) W (hp)		(2) 0.25 (1/3)	(2) 0.25 (1/3)	(2) 0.25 (1/3)	(2) 373 (1/2)	
	Motor rev/min		896	896	896	1075	
	Total Motor watts		554	554	554	802	
	Diameter - (No.) mm (in.)		(2) 610 (24)	(2) 610 (24)	(2) 610 (24)	(2) 610 (24)	
	Number of blades		3	3	3	3	
	Total Air volume - L/s (cfm)		3146 (6665)	3146 (6665)	3146 (6665)	3815 (8085)	
Indoor Coils	Net face area (total) - m ² (sq. ft.)		1.19 (12.78)	1.19 (12.78)	1.26 (13.54)	1.26 (13.54)	
	Tube diameter - mm (in.)		9.5 (3/8)	9.5 (3/8)	9.5 (3/8)	9.5 (3/8)	
	Number of rows		4	4	4	4	
	Fins per m (Fins per inch)		551 (14)	551 (14)	551 (14)	551 (14)	
	Drain connection - Number and size		(1) 1 in. NPT coupling				
Expansion device type		Balance port TXV, removable head					
⁴ Indoor Blower and Drive Selection	Nominal motor kW (HP)		1.5 (2)	1.5 (2)	1.5 (2)	1.5 (2)	
	Maximum usable motor kW (HP)		1.7 (2.3)	1.7 (2.3)	1.7 (2.3)	1.7 (2.3)	
	Kit # (rev/min range)	#1 (490-740)		#1 (490-740)	#1 (490-740)	#1 (490-740)	#1 (490-740)
		#2 (665-920)		#2 (665-920)	#2 (665-920)	#2 (665-920)	#2 (665-920)
		#3 (660-995)		#3 (660-995)	#3 (660-995)	#3 (660-995)	#3 (660-995)
	Nominal motor kW (HP)		2.2 (3)	2.2 (3)	2.2 (3)	2.2 (3)	
	Maximum usable motor kW (HP)		2.6 (3.45)	2.6 (3.45)	2.6 (3.45)	2.6 (3.45)	
	Kit # (rev/min range)	#7 (610-810)		#7 (610-810)	#7 (610-810)	#7 (610-810)	#7 (610-810)
		#8 (780-1000)		#8 (780-1000)	#8 (780-1000)	#8 (780-1000)	#8 (780-1000)
		#9 (845-1085)		#9 (845-1085)	#9 (845-1085)	#9 (845-1085)	#9 (845-1085)
	Nominal motor kW (HP)		3.7 (5)	3.7 (5)	3.7 (5)	3.7 (5)	
	Maximum usable motor kW (HP)		4.3 (5.75)	4.3 (5.75)	4.3 (5.75)	4.3 (5.75)	
Kit # (rev/min range)	#10 (750-945)		#10 (750-945)	#10 (750-945)	#10 (750-945)	#10 (750-945)	
	#11 (865-1095)		#11 (865-1095)	#11 (865-1095)	#11 (865-1095)	#11 (865-1095)	
	#12 (940-1190)		#12 (940-1190)	#12 (940-1190)	#12 (940-1190)	#12 (940-1190)	
Blower wheel nominal diameter x width - mm (in.)		(1) 381 x 381 (15 X 15)	(1) 381 x 381 (15 X 15)	(1) 381 x 381 (15 X 15)	(1) 381 x 381 (15 X 15)		
Filters	Type of filter		Disposable				
	Number and size - mm (in.)		(4) 508 x 508 x 51 (20 x 25 x 2)				
Electrical characteristics			380/420V - 50 hertz - 3 phase with neutral (No neutral on CE marked models)				

NOTE - Net capacity includes evaporator blower motor heat deduction. Gross capacity does not include evaporator blower motor heat deduction.

¹ Tested at conditions included in the USE certification program, which is based on AHRI Standard 340/360; 35°C (95°F) outdoor air temperature and 27°C (80°F) dry bulb/19°C (67°F) wet bulb entering evaporator air; minimum external duct static pressure while operating at rated voltage and air volumes.

² Rated at 46°C (115°F) outdoor air temperature and 27°C (80°F) db/19°C (67°F) wb entering evaporator air (T3 Conditions).

³ Integrated Energy Efficiency Ratio tested at conditions included in AHRI Standard 340/360 while operating at rated voltage and air volumes.

⁴ Using total air volume and system static pressure requirements determine from blower performance tables rev/min and motor output required. Maximum usable output of motors furnished are shown. If motors of comparable output are used, be sure to keep within the service factor limitations outlined on the motor nameplate.

SPECIFICATIONS - GAS HEAT

			Standard	Medium	High
Heat Input Type					
Number of Gas Heat Stages			2	2	2
Gas Heating Performance	Input - kW (Btuh)	First Stage	24.8 (84 500)	34.3 (117 000)	45.7 (156 000)
		Second Stage	33.4 (114 000)	46.7 (159 500)	61.5 (210 000)
	Output - kW (Btuh)	Second Stage	26.7 (91 200)	36.9 (126 000)	49.2 (168 000)
	Temperature Rise Range - °C (°F)		8 - 25 (15 - 45)	17 - 33 (30 - 60)	22 - 39 (40 - 70)
	Thermal Efficiency		81%	81%	81%
	Gas Supply Connections		3/4 in. NPT	3/4 in. NPT	3/4 in. NPT
Recommended Gas Supply Pressure - kPa (in. w.g.)	Natural		0.70 (2.8)	0.70 (2.8)	0.70 (2.8)
	LPG/Propane		1.97 (7.9)	1.97 (7.9)	1.97 (7.9)

HIGH ALTITUDE DERATE

Units may be installed at altitudes up to 610 m (2000 feet) above sea level without any modification.

At altitudes above 610 m (2000 feet), units must be derated to match gas manifold pressures shown in table below.

At altitudes above 1372 m (4500 feet) unit must be derated 2% for each 305 m (1000 feet) above sea level.

NOTE - This is the only permissible derate for these units.

Gas Heat Type	Altitude m (Feet)	Gas Manifold Pressure kPa (in. w.g.)		Input Rate - Btuh (Natural Gas or LPG/Propane)	
		Natural Gas	LPG/Propane Gas	First Stage	Second Stage
Standard	610 - 1372 (2001-4500)	0.62 (2.5)	1.82 (7.3)	24.8 (84 500)	31.7 (108 000)
Medium	610 - 1372 (2001-4500)	0.62 (2.5)	1.82 (7.3)	34.3 (117 000)	43.7 (149 000)
High	610 - 1372 (2001-4500)	0.62 (2.5)	1.82 (7.3)	45.7 (156 000)	58 (198 000)

RATINGS

NOTE - For Temperatures and Capacities not shown in tables, see bulletin - Cooling Unit Rating Table Correction Factor Data in Miscellaneous Engineering Data section.

26 KW LGH092H4B (1ST STAGE)

Entering Wet Bulb Temperature	Total Air Volume	Outdoor Air Temperature Entering Outdoor Coil																			
		18.3°C					23.9°C					29.4°C					35°C				
		Total Cool Cap.	Comp. Motor Input	Sensible To Total Ratio (S/T)			Total Cool Cap.	Comp. Motor Input	Sensible To Total Ratio (S/T)			Total Cool Cap.	Comp. Motor Input	Sensible To Total Ratio (S/T)			Total Cool Cap.	Comp. Motor Input	Sensible To Total Ratio (S/T)		
				Dry Bulb					Dry Bulb					Dry Bulb					Dry Bulb		
L/s	kW	kW	24°C	27°C	29°C	kW	kW	24°C	27°C	29°C	kW	kW	24°C	27°C	29°C	kW	kW	24°C	27°C	29°C	
17.2°C	1135	12.4	1.62	0.7	0.85	1	11.9	1.83	0.71	0.87	1	11.3	2.06	0.72	0.89	1	10.6	2.33	0.74	0.93	1
	1415	13	1.62	0.76	0.95	1	12.5	1.83	0.77	0.98	1	11.8	2.07	0.78	1	1	11.2	2.33	0.81	1	1
	1700	13.6	1.63	0.81	1	1	13	1.84	0.84	1	1	12.5	2.07	0.86	1	1	11.8	2.33	0.9	1	1
19.4°C	1135	13.2	1.62	0.55	0.68	0.81	12.6	1.83	0.56	0.69	0.83	12	2.07	0.56	0.7	0.85	11.3	2.33	0.56	0.72	0.89
	1415	13.8	1.63	0.59	0.74	0.91	13.2	1.84	0.6	0.75	0.94	12.5	2.07	0.6	0.76	0.97	11.8	2.33	0.61	0.78	1
	1700	14.2	1.63	0.61	0.79	1	13.6	1.84	0.63	0.81	1	12.9	2.07	0.63	0.84	1	12.1	2.33	0.65	0.87	1
21.7°C	1135	13.9	1.63	0.41	0.53	0.66	13.3	1.84	0.42	0.53	0.67	12.7	2.07	0.42	0.55	0.68	12	2.33	0.42	0.56	0.7
	1415	14.5	1.63	0.43	0.57	0.72	13.9	1.84	0.44	0.59	0.73	13.2	2.07	0.44	0.59	0.74	12.5	2.33	0.43	0.6	0.76
	1700	15	1.64	0.45	0.61	0.77	14.3	1.85	0.44	0.62	0.79	13.5	2.08	0.45	0.63	0.82	12.8	2.34	0.45	0.64	0.84

26 KW LGH092H4B (2ND STAGE)

Entering Wet Bulb Temperature	Total Air Volume	Outdoor Air Temperature Entering Outdoor Coil																			
		26.7°C					35°C					43.3°C					46°C				
		Total Cool Cap.	Comp. Motor Input	Sensible To Total Ratio (S/T)			Total Cool Cap.	Comp. Motor Input	Sensible To Total Ratio (S/T)			Total Cool Cap.	Comp. Motor Input	Sensible To Total Ratio (S/T)			Total Cool Cap.	Comp. Motor Input	Sensible To Total Ratio (S/T)		
				Dry Bulb					Dry Bulb					Dry Bulb					Dry Bulb		
L/s	kW	kW	24°C	27°C	29°C	kW	kW	24°C	27°C	29°C	kW	kW	24°C	27°C	29°C	kW	kW	24°C	27°C	29°C	
17.2°C	1135	23.2	3.89	0.72	0.88	1	21.3	4.66	0.74	0.93	1	19.3	5.61	0.76	0.98	1	18.8	5.97	.82	1.00	1.00
	1415	24.3	3.89	0.78	0.99	1	22.5	4.66	0.81	1	1	20.6	5.62	0.86	1	1	20.1	5.96	.91	1.00	1.00
	1700	25.5	3.9	0.85	1	1	23.7	4.67	0.9	1	1	21.6	5.62	0.96	1	1	21.1	5.96	.99	1.00	1.00
19.4°C	1135	24.6	3.9	0.55	0.69	0.84	22.6	4.66	0.57	0.72	0.89	20.5	5.61	0.58	0.74	0.94	19.8	5.96	.61	.81	.94
	1415	25.7	3.9	0.6	0.76	0.95	23.6	4.67	0.61	0.78	0.99	21.3	5.62	0.62	0.83	1	20.6	5.96	.67	.90	1.00
	1700	26.4	3.91	0.63	0.83	1	24.3	4.67	0.65	0.87	1	22	5.62	0.68	0.94	1	21.2	5.97	.73	.99	1.00
21.7°C	1135	26	3.91	0.41	0.53	0.67	24	4.67	0.42	0.56	0.7	21.8	5.62	0.42	0.57	0.72	21.0	5.96	.43	.61	.73
	1415	27.1	3.91	0.43	0.59	0.74	24.9	4.67	0.43	0.6	0.76	22.6	5.62	0.44	0.62	0.8	21.9	5.96	.45	.67	.82
	1700	27.9	3.92	0.45	0.62	0.8	25.6	4.68	0.45	0.64	0.84	23.2	5.62	0.46	0.68	0.91	22.4	5.96	.48	.74	.91

Entering Wet Bulb Temperature	Total Air Volume	Outdoor Air Temperature Entering Outdoor Coil																	
		48°C					50°C					51.7°C							
		Total Cool Cap.	Comp. Motor Input	Sensible To Total Ratio (S/T)			Total Cool Cap.	Comp. Motor Input	Sensible To Total Ratio (S/T)			Total Cool Cap.	Comp. Motor Input	Sensible To Total Ratio (S/T)					
				Dry Bulb					Dry Bulb					Dry Bulb					
L/s	kW	kW	24°C	27°C	29°C	kW	kW	24°C	27°C	29°C	kW	kW	24°C	27°C	29°C				
17.2°C	1135	18.2	6.25	0.78	1	1	17.7	6.55	0.80	1	1	17.3	6.81	0.81	1	1			
	1415	19.5	6.25	0.90	1	1	18.9	6.54	0.92	1	1	18.4	6.8	0.94	1	1			
	1700	20.4	6.25	0.99	1	1	19.8	6.54	1.00	1	1	19.4	6.8	1	1	1			
19.4°C	1135	19.2	6.25	0.59	0.76	0.98	18.7	6.55	0.59	0.77	0.99	18.2	6.81	0.6	0.79	1			
	1415	20.0	6.25	0.64	0.87	1	19.4	6.54	0.65	0.89	1	18.9	6.8	0.66	0.91	1			
	1700	20.5	6.25	0.70	0.98	1	19.9	6.54	0.71	0.99	1	19.4	6.8	0.71	1	1			
21.7°C	1135	20.4	6.25	0.42	0.58	0.74	19.8	6.54	0.42	0.58	0.75	19.3	6.8	0.42	0.59	0.76			
	1415	21.2	6.24	0.44	0.63	0.84	20.6	6.54	0.44	0.65	0.86	20	6.79	0.45	0.66	0.88			
	1700	21.7	6.24	0.47	0.69	0.95	21.1	6.54	0.47	0.70	0.97	20.5	6.79	0.47	0.71	0.99			

RATINGS

NOTE - For Temperatures and Capacities not shown in tables, see bulletin - Cooling Unit Rating Table Correction Factor Data in Miscellaneous Engineering Data section.

30 KW - LGH102H4B (1ST STAGE)

Entering Wet Bulb Temperature	Total Air Volume	Outdoor Air Temperature Entering Outdoor Coil																							
		18.3°C						23.9°C						29.4°C						35°C					
		Total Cool Cap.	Comp. Motor Input	Sensible To Total Ratio (S/T)			Total Cool Cap.	Comp. Motor Input	Sensible To Total Ratio (S/T)			Total Cool Cap.	Comp. Motor Input	Sensible To Total Ratio (S/T)			Total Cool Cap.	Comp. Motor Input	Sensible To Total Ratio (S/T)						
				Dry Bulb					Dry Bulb					Dry Bulb					Dry Bulb						
L/s	kW	kW	24°C	27°C	29°C	kW	kW	24°C	27°C	29°C	kW	kW	24°C	27°C	29°C	kW	kW	24°C	27°C	29°C					
17.2°C	1285	13.8	1.79	0.64	0.82	1	13	2.03	0.65	0.85	1	12.2	2.29	0.66	0.89	1	11.3	2.59	0.67	0.93	1				
	1605	14.5	1.8	0.7	0.97	1	13.7	2.04	0.71	0.99	1	12.9	2.3	0.72	1	1	12.1	2.6	0.76	1	1				
	1925	15.2	1.81	0.77	1	1	14.4	2.04	0.79	1	1	13.6	2.3	0.83	1	1	12.8	2.6	0.88	1	1				
19.4°C	1285	14.7	1.8	0.5	0.63	0.77	13.9	2.04	0.5	0.63	0.79	13.1	2.3	0.51	0.65	0.83	12.1	2.6	0.51	0.66	0.87				
	1605	15.4	1.81	0.54	0.68	0.91	14.5	2.04	0.54	0.69	0.95	13.6	2.3	0.54	0.7	0.98	12.7	2.6	0.55	0.72	1				
	1925	15.9	1.81	0.56	0.74	1	15	2.05	0.57	0.77	1	14.1	2.31	0.57	0.8	1	13.1	2.6	0.59	0.86	1				
21.7°C	1285	15.6	1.81	0.38	0.49	0.61	14.7	2.04	0.37	0.49	0.61	13.9	2.3	0.37	0.5	0.63	13	2.6	0.37	0.5	0.64				
	1605	16.3	1.82	0.4	0.53	0.66	15.4	2.05	0.39	0.54	0.68	14.5	2.31	0.38	0.54	0.68	13.5	2.6	0.38	0.55	0.71				
	1925	16.8	1.82	0.41	0.56	0.71	15.9	2.05	0.41	0.57	0.74	14.9	2.31	0.4	0.58	0.76	13.9	2.61	0.4	0.58	0.82				

30 KW - LGH102H4B (2ND STAGE)

Entering Wet Bulb Temperature	Total Air Volume	Outdoor Air Temperature Entering Outdoor Coil																							
		26.7°C						35°C						43.3°C						46°C					
		Total Cool Cap.	Comp. Motor Input	Sensible To Total Ratio (S/T)			Total Cool Cap.	Comp. Motor Input	Sensible To Total Ratio (S/T)			Total Cool Cap.	Comp. Motor Input	Sensible To Total Ratio (S/T)			Total Cool Cap.	Comp. Motor Input	Sensible To Total Ratio (S/T)						
				Dry Bulb					Dry Bulb					Dry Bulb					Dry Bulb						
L/s	kW	kW	24°C	27°C	29°C	kW	kW	24°C	27°C	29°C	kW	kW	24°C	27°C	29°C	kW	kW	24°C	27°C	29°C					
17.2°C	1285	26.1	4.32	0.73	0.91	1	23.5	5.19	0.75	0.95	1	20.7	6.27	0.77	1	1	20.4	6.89	.81	1.00	1.00				
	1605	27.5	4.33	0.79	1	1	25.1	5.2	0.83	1	1	22.4	6.27	0.88	1	1	22.1	6.86	.92	1.00	1.00				
	1925	29	4.34	0.87	1	1	26.4	5.2	0.92	1	1	23.7	6.28	0.98	1	1	23.4	6.83	1.00	1.00	1.00				
19.4°C	1285	27.9	4.33	0.57	0.71	0.87	25.2	5.2	0.57	0.73	0.91	22.2	6.27	0.57	0.75	0.96	21.7	6.87	.59	.81	.95				
	1605	29.1	4.34	0.61	0.78	0.98	26.3	5.2	0.61	0.8	1	23.2	6.27	0.62	0.85	1	22.7	6.84	.65	.91	1.00				
	1925	30	4.35	0.64	0.85	1	27.1	5.21	0.66	0.9	1	24	6.28	0.68	0.96	1	23.4	6.82	.72	1.00	1.00				
21.7°C	1285	29.6	4.34	0.41	0.56	0.69	26.8	5.21	0.41	0.56	0.71	23.8	6.27	0.39	0.56	0.73	23.4	6.83	.40	.59	.73				
	1605	30.9	4.35	0.43	0.6	0.76	28	5.21	0.42	0.61	0.79	24.8	6.27	0.42	0.62	0.82	24.4	6.81	.43	.66	.82				
	1925	31.9	4.36	0.45	0.64	0.83	28.8	5.22	0.45	0.65	0.87	25.6	6.28	0.45	0.68	0.94	25.1	6.80	.46	.73	.91				

Entering Wet Bulb Temperature	Total Air Volume	Outdoor Air Temperature Entering Outdoor Coil																	
		48°C						50°C						51.7°C					
		Total Cool Cap.	Comp. Motor Input	Sensible To Total Ratio (S/T)			Total Cool Cap.	Comp. Motor Input	Sensible To Total Ratio (S/T)			Total Cool Cap.	Comp. Motor Input	Sensible To Total Ratio (S/T)					
				Dry Bulb					Dry Bulb					Dry Bulb					
L/s	kW	kW	24°C	27°C	29°C	kW	kW	24°C	27°C	29°C	kW	kW	24°C	27°C	29°C				
17.2°C	1285	19.5	7.25	0.79	1	1	18.8	7.65	0.80	1	1	18.1	7.63	0.82	1	1			
	1605	21.2	7.20	0.91	1	1	20.5	7.58	0.93	1	1	19.5	7.61	0.96	1	1			
	1925	22.5	7.18	1	1	1	21.7	7.55	1.00	1	1	20.7	7.62	1	1	1			
19.4°C	1285	20.9	7.23	0.57	0.76	0.99	20.1	7.61	0.57	0.78	1.00	19.1	7.62	0.58	0.8	1			
	1605	21.9	7.19	0.63	0.88	1.00	21.1	7.58	0.64	0.90	1.00	20	7.62	0.65	0.93	1			
	1925	22.6	7.18	0.69	0.98	1.00	21.7	7.53	0.70	1.00	1.00	20.6	7.61	0.71	1	1			
21.7°C	1285	22.5	7.18	0.38	0.56	0.74	21.7	7.56	0.37	0.57	0.75	20.5	7.61	0.38	0.58	0.78			
	1605	23.5	7.16	0.41	0.62	0.85	22.7	7.51	0.40	0.63	0.87	21.5	7.61	0.41	0.65	0.9			
	1925	24.2	7.16	0.44	0.69	0.96	23.4	7.52	0.44	0.70	0.98	22	7.61	0.44	0.72	1			

RATINGS

NOTE - For Temperatures and Capacities not shown in tables, see bulletin - Cooling Unit Rating Table Correction Factor Data in Miscellaneous Engineering Data section.

35 KW LGH120H4B (1ST STAGE)

Entering Wet Bulb Temperature	Total Air Volume	Outdoor Air Temperature Entering Outdoor Coil																			
		18.3°C					23.9°C					29.4°C					35°C				
		Total Cool Cap.	Comp. Motor Input	Sensible To Total Ratio (S/T)			Total Cool Cap.	Comp. Motor Input	Sensible To Total Ratio (S/T)			Total Cool Cap.	Comp. Motor Input	Sensible To Total Ratio (S/T)			Total Cool Cap.	Comp. Motor Input	Sensible To Total Ratio (S/T)		
				Dry Bulb					Dry Bulb					Dry Bulb					Dry Bulb		
L/s	kW	kW	24°C	27°C	29°C	kW	kW	24°C	27°C	29°C	kW	kW	24°C	27°C	29°C	kW	kW	24°C	27°C	29°C	
17.2°C	1510	17.5	2.32	0.69	0.85	1	16.6	2.63	0.7	0.87	1	15.7	2.99	0.71	0.89	1	14.7	3.39	0.73	0.93	1
	1890	18.3	2.34	0.75	0.95	1	17.4	2.65	0.76	0.98	1	16.5	3	0.78	1	1	15.6	3.4	0.8	1	1
	2265	19	2.36	0.81	1	1	18.2	2.68	0.82	1	1	17.3	3.03	0.85	1	1	16.4	3.43	0.88	1	1
19.4°C	1510	18.5	2.34	0.55	0.67	0.81	17.6	2.66	0.55	0.68	0.83	16.7	3	0.55	0.69	0.85	15.7	3.41	0.56	0.71	0.88
	1890	19.4	2.37	0.58	0.73	0.91	18.4	2.69	0.59	0.74	0.94	17.5	3.03	0.59	0.76	0.97	16.4	3.43	0.6	0.77	0.99
	2265	20	2.38	0.61	0.79	0.99	19	2.7	0.62	0.8	1	18	3.05	0.63	0.83	1	16.9	3.44	0.63	0.86	1
21.7°C	1510	19.6	2.37	0.41	0.54	0.65	18.7	2.69	0.39	0.54	0.66	17.7	3.04	0.41	0.54	0.67	16.7	3.44	0.4	0.55	0.69
	1890	20.5	2.4	0.43	0.57	0.71	19.5	2.72	0.43	0.58	0.73	18.5	3.07	0.42	0.59	0.74	17.4	3.46	0.43	0.59	0.75
	2265	21.1	2.42	0.45	0.61	0.77	20.1	2.74	0.44	0.61	0.78	19	3.09	0.44	0.62	0.8	17.9	3.48	0.44	0.63	0.83

35 KW - LGH120H4B (2ND STAGE)

Entering Wet Bulb Temperature	Total Air Volume	Outdoor Air Temperature Entering Outdoor Coil																			
		26.7°C					35°C					43.3°C					46°C				
		Total Cool Cap.	Comp. Motor Input	Sensible To Total Ratio (S/T)			Total Cool Cap.	Comp. Motor Input	Sensible To Total Ratio (S/T)			Total Cool Cap.	Comp. Motor Input	Sensible To Total Ratio (S/T)			Total Cool Cap.	Comp. Motor Input	Sensible To Total Ratio (S/T)		
				Dry Bulb					Dry Bulb					Dry Bulb					Dry Bulb		
L/s	kW	kW	24°C	27°C	29°C	kW	kW	24°C	27°C	29°C	kW	kW	24°C	27°C	29°C	kW	kW	24°C	27°C	29°C	
17.2°C	1510	32.3	5.61	0.71	0.88	1	29.5	6.8	0.73	0.93	1	26.4	8.29	0.75	0.98	1	24.8	8.44	.82	1.00	1.00
	1890	33.9	5.65	0.77	0.99	1	31	6.82	0.79	1	1	28.2	8.3	0.84	1	1	26.7	8.52	.92	1.00	1.00
	2265	35.4	5.7	0.84	1	1	32.8	6.87	0.88	1	1	29.7	8.31	0.95	1	1	28.1	8.57	1.00	1.00	1.00
19.4°C	1510	34.3	5.67	0.55	0.69	0.84	31.4	6.84	0.56	0.71	0.88	28.2	8.28	0.56	0.73	0.94	26.2	8.49	.60	.82	.96
	1890	35.9	5.72	0.59	0.75	0.95	32.7	6.86	0.6	0.77	0.99	29.4	8.31	0.61	0.82	1	27.3	8.54	.66	.91	1.00
	2265	36.9	5.75	0.62	0.81	1	33.7	6.89	0.63	0.86	1	30.3	8.34	0.66	0.92	1	28.1	8.57	.73	1.00	1.00
21.7°C	1510	36.3	5.72	0.39	0.54	0.67	33.4	6.88	0.4	0.55	0.69	30.1	8.32	0.4	0.56	0.71	28.0	8.57	.41	.61	.74
	1890	37.9	5.78	0.42	0.58	0.73	34.8	6.93	0.43	0.59	0.75	31.3	8.36	0.41	0.61	0.79	29.1	8.61	.44	.67	.83
	2265	39	5.82	0.44	0.62	0.79	35.8	6.96	0.44	0.63	0.84	32.2	8.37	0.44	0.65	0.89	29.9	8.65	.47	.74	.91

Entering Wet Bulb Temperature	Total Air Volume	Outdoor Air Temperature Entering Outdoor Coil														
		48°C					50°C					51.7°C				
		Total Cool Cap.	Comp. Motor Input	Sensible To Total Ratio (S/T)			Total Cool Cap.	Comp. Motor Input	Sensible To Total Ratio (S/T)			Total Cool Cap.	Comp. Motor Input	Sensible To Total Ratio (S/T)		
				Dry Bulb					Dry Bulb					Dry Bulb		
L/s	kW	kW	24°C	27°C	29°C	kW	kW	24°C	27°C	29°C	kW	kW	24°C	27°C	29°C	
17.2°C	1510	24.5	9.29	0.77	1	1	23.7	9.76	0.78	1	1	23.1	10.2	0.79	1	1
	1890	26.5	9.28	0.88	1	1	25.6	9.77	0.90	1	1	24.9	10.14	0.92	1	1
	2265	27.8	9.30	0.99	1	1	27.0	9.76	1	1	1	26.3	10.15	1	1	1
19.4°C	1510	26.2	9.27	0.57	0.75	0.97	25.3	9.77	0.57	0.75	0.99	24.6	10.2	0.57	0.76	1
	1890	27.4	9.28	0.62	0.85	1.00	26.4	9.76	0.62	0.87	1.00	25.6	10.18	0.63	0.89	1
	2265	28.2	9.31	0.67	0.96	1.00	27.3	9.75	0.68	0.98	1.00	26.4	10.16	0.69	0.99	1
21.7°C	1510	28.1	9.31	0.39	0.56	0.73	27.1	9.75	0.39	0.56	0.73	26.3	10.17	0.39	0.57	0.74
	1890	29.2	9.29	0.41	0.61	0.82	28.2	9.74	0.41	0.62	0.84	27.4	10.16	0.41	0.62	0.86
	2265	30.1	9.34	0.44	0.67	0.94	29.1	9.79	0.44	0.68	0.96	28.2	10.18	0.44	0.69	0.97

RATINGS

NOTE - For Temperatures and Capacities not shown in tables, see bulletin - Cooling Unit Rating Table Correction Factor Data in Miscellaneous Engineering Data section.

44 kW - LGH150H4B (1ST STAGE)

Entering Wet Bulb Temperature	Total Air Volume	Outdoor Air Temperature Entering Outdoor Coil																			
		18.3°C					23.8°C					29.4°C					35°C				
		Total Cool Cap.	Comp. Motor Input	Sensible To Total Ratio (S/T)			Total Cool Cap.	Comp. Motor Input	Sensible To Total Ratio (S/T)			Total Cool Cap.	Comp. Motor Input	Sensible To Total Ratio (S/T)			Total Cool Cap.	Comp. Motor Input	Sensible To Total Ratio (S/T)		
				Dry Bulb					Dry Bulb					Dry Bulb					Dry Bulb		
L/s	kW	kW	24°C	27°C	29°C	kW	kW	24°C	27°C	29°C	kW	kW	24°C	27°C	29°C	kW	kW	24°C	27°C	29°C	
17.2°C	1793	19.8	2.85	0.71	0.86	1.00	18.5	3.16	0.71	0.88	1.00	17.2	3.49	0.72	0.91	1.00	15.7	3.87	0.72	0.93	1.00
	2077	20.5	2.86	0.74	0.93	1.00	19.3	3.17	0.75	0.94	1.00	17.9	3.50	0.76	0.97	1.00	16.5	3.88	0.78	1.00	1.00
	2360	21.2	2.87	0.78	0.98	1.00	19.9	3.17	0.79	1.00	1.00	18.5	3.51	0.81	1.00	1.00	17.2	3.88	0.83	1.00	1.00
19.4°C	1793	21.3	2.87	0.55	0.68	0.83	20.0	3.17	0.54	0.69	0.84	18.6	3.51	0.54	0.70	0.86	17.1	3.88	0.53	0.70	0.88
	2077	22.0	2.88	0.57	0.72	0.89	20.7	3.18	0.57	0.73	0.91	19.3	3.52	0.57	0.74	0.93	17.7	3.88	0.57	0.75	0.96
	2360	22.7	2.89	0.60	0.76	0.94	21.3	3.19	0.60	0.77	0.97	19.8	3.52	0.60	0.79	0.99	18.3	3.89	0.60	0.80	1.00
21.7°C	1793	22.7	2.89	0.42	0.55	0.67	21.4	3.19	0.40	0.54	0.67	20.0	3.52	0.39	0.53	0.67	18.5	3.89	0.38	0.53	0.68
	2077	23.6	2.90	0.42	0.57	0.70	22.2	3.20	0.42	0.57	0.71	20.7	3.53	0.40	0.56	0.71	19.1	3.90	0.39	0.56	0.73
	2360	24.1	2.91	0.44	0.59	0.73	22.8	3.21	0.43	0.59	0.75	21.2	3.54	0.42	0.59	0.76	19.7	3.91	0.41	0.60	0.78

44 kW - LGH150H4B (2ND STAGE)

Entering Wet Bulb Temperature	Total Air Volume	Outdoor Air Temperature Entering Outdoor Coil																			
		29.4°C					35°C					43.3°C					46°C				
		Total Cool Cap.	Comp. Motor Input	Sensible To Total Ratio (S/T)			Total Cool Cap.	Comp. Motor Input	Sensible To Total Ratio (S/T)			Total Cool Cap.	Comp. Motor Input	Sensible To Total Ratio (S/T)			Total Cool Cap.	Comp. Motor Input	Sensible To Total Ratio (S/T)		
				Dry Bulb					Dry Bulb					Dry Bulb					Dry Bulb		
L/s	kW	kW	24°C	27°C	29°C	kW	kW	24°C	27°C	29°C	kW	kW	24°C	27°C	29°C	kW	kW	24°C	27°C	29°C	
17.2°C	1795	37.7	7.59	.73	.90	1.00	34.6	8.42	.74	.92	1.00	29.9	9.86	.78	.99	1.00	28.4	10.39	.79	1.00	1.00
	2075	39.2	7.61	.78	.96	1.00	36.1	8.45	.79	.99	1.00	31.7	9.89	.83	1.00	1.00	30.3	10.43	.85	1.00	1.00
	2360	40.5	7.64	.82	1.00	1.00	37.6	8.47	.84	1.00	1.00	33.4	9.92	.89	1.00	1.00	31.9	10.44	.91	1.00	1.00
19.4°C	1795	40.6	7.63	.55	.71	.86	37.5	8.46	.55	.72	.88	32.6	9.91	.56	.77	.91	30.9	10.43	.56	.78	.93
	2075	42.1	7.66	.58	.75	.92	38.8	8.49	.58	.77	.95	33.8	9.93	.60	.83	.98	32.0	10.45	.60	.84	.99
	2360	43.3	7.69	.61	.80	.98	40.0	8.51	.61	.81	1.00	34.8	9.94	.63	.89	1.00	32.9	10.47	.64	.90	1.00
21.7°C	1795	43.6	7.68	.40	.55	.69	40.4	8.51	.39	.54	.70	35.5	9.96	.37	.56	.69	33.7	10.48	.36	.56	.70
	2075	45.0	7.71	.42	.58	.73	41.7	8.54	.40	.58	.75	36.7	9.98	.39	.61	.75	34.9	10.50	.38	.61	.75
	2360	46.2	7.73	.43	.61	.77	42.9	8.56	.42	.61	.79	37.7	10.00	.41	.64	.79	35.9	10.53	.40	.65	.81

Entering Wet Bulb Temperature	Total Air Volume	Outdoor Air Temperature Entering Outdoor Coil																	
		48°C					50°C					51.7°C							
		Total Cool Cap.	Comp. Motor Input	Sensible To Total Ratio (S/T)			Total Cool Cap.	Comp. Motor Input	Sensible To Total Ratio (S/T)			Total Cool Cap.	Comp. Motor Input	Sensible To Total Ratio (S/T)					
				Dry Bulb					Dry Bulb					Dry Bulb					
L/s	kW	kW	24°C	27°C	29°C	kW	kW	24°C	27°C	29°C	kW	kW	24°C	27°C	29°C				
17.2°C	1795	27.0	10.80	.78	1.00	1.00	25.8	11.23	.79	1.00	1.00	25.2	11.60	.81	1.00	1.00			
	2075	28.8	10.84	.84	1.00	1.00	27.6	11.26	.86	1.00	1.00	27.0	11.63	.88	1.00	1.00			
	2360	30.3	10.86	.90	1.00	1.00	29.2	11.29	.92	1.00	1.00	28.5	11.66	.96	1.00	1.00			
19.4°C	1795	29.6	10.84	.54	.75	.96	28.3	11.27	.54	.76	.98	27.1	11.62	.56	.81	.97			
	2075	30.7	10.86	.58	.82	1.00	29.4	11.29	.58	.83	1.00	28.2	11.66	.60	.88	1.00			
	2360	31.5	10.88	.62	.88	1.00	30.2	11.30	.62	.89	1.00	29.0	11.67	.64	.95	1.00			
21.7°C	1795	32.2	10.90	.34	.54	.73	30.9	11.32	.34	.54	.74	29.9	11.68	.34	.57	.72			
	2075	33.4	10.91	.37	.58	.79	32.0	11.33	.36	.58	.80	30.9	11.70	.36	.61	.78			
	2360	34.3	10.93	.39	.62	.85	32.8	11.34	.38	.62	.87	31.7	11.72	.38	.66	.84			

BLOWER DATA

BELT DRIVE BLOWER - BASE UNIT

BLOWER TABLE INCLUDES RESISTANCE FOR BASE UNIT ONLY (NO HEAT SECTION) WITH DRY INDOOR COIL AND AIR FILTERS IN PLACE. FOR ALL UNITS ADD:

- 1 - Wet indoor coil air resistance of selected unit.
- 2 - Any factory installed options air resistance (heat section, economizer, etc.)
- 3 - Any field installed accessories air resistance (duct resistance, diffuser, etc.)

Then determine from blower table blower motor output required.

See page 26 for blower motors and drives. See page 26 for wet coil and option/accessory air resistance data.

Total Air Volume		TOTAL STATIC PRESSURE - Pa (Inches Water Gauge)																				
		50 (0.20)			100 (0.40)			150 (0.60)			200 (0.80)			250 (1.00)			300 (1.20)			350 (1.40)		
L/s	cfm	rev/min	kW	BHP	rev/min	kW	BHP	rev/min	kW	BHP	rev/min	kW	BHP	rev/min	kW	BHP	rev/min	kW	BHP	rev/min	kW	BHP
1060	2250	587	0.06	0.08	637	0.23	0.31	690	0.42	0.56	746	0.61	0.82	805	0.79	1.06	865	0.95	1.28	927	1.09	1.46
1180	2500	601	0.18	0.24	650	0.35	0.47	703	0.53	0.71	757	0.71	0.95	815	0.88	1.18	875	1.04	1.40	938	1.17	1.57
1300	2750	616	0.31	0.41	664	0.46	0.62	715	0.63	0.85	769	0.81	1.09	826	0.98	1.31	886	1.13	1.52	950	1.27	1.70
1415	3000	632	0.43	0.58	679	0.59	0.79	729	0.75	1.01	782	0.92	1.23	839	1.08	1.45	899	1.24	1.66	963	1.37	1.84
1535	3250	649	0.57	0.76	695	0.72	0.96	744	0.87	1.17	797	1.04	1.39	853	1.19	1.60	913	1.35	1.81	976	1.48	1.99
1650	3500	666	0.71	0.95	712	0.85	1.14	761	1.01	1.35	813	1.16	1.55	868	1.31	1.76	929	1.47	1.97	990	1.62	2.17
1770	3750	685	0.87	1.16	730	1.00	1.34	779	1.14	1.53	830	1.30	1.74	886	1.45	1.94	946	1.60	2.15	1005	1.76	2.36
1890	4000	706	1.02	1.37	750	1.16	1.55	798	1.29	1.73	849	1.44	1.93	905	1.60	2.14	965	1.75	2.35	1019	1.92	2.57
2005	4250	727	1.19	1.60	772	1.32	1.77	819	1.45	1.95	871	1.60	2.15	926	1.75	2.35	984	1.92	2.58	1034	2.09	2.80
2125	4500	750	1.37	1.84	795	1.50	2.01	843	1.63	2.19	894	1.77	2.38	949	1.93	2.59	1003	2.11	2.83	1050	2.29	3.07
2240	4750	775	1.57	2.10	820	1.69	2.26	868	1.82	2.44	919	1.96	2.63	972	2.13	2.86	1023	2.32	3.11	1067	2.51	3.36
2360	5000	802	1.77	2.37	847	1.89	2.53	895	2.02	2.71	945	2.17	2.91	997	2.36	3.16	1044	2.56	3.43	1087	2.75	3.69
2480	5250	831	1.99	2.67	876	2.11	2.83	924	2.24	3.01	973	2.41	3.23	1022	2.61	3.50	1066	2.82	3.78	1108	3.01	4.04
2595	5500	862	2.22	2.98	907	2.34	3.14	955	2.48	3.33	1002	2.68	3.59	1048	2.90	3.89	1090	3.11	4.17	1132	3.30	4.42
2715	5750	895	2.47	3.31	940	2.60	3.48	987	2.77	3.71	1032	2.99	4.01	1075	3.22	4.32	1116	3.42	4.59	1158	3.59	4.82
2830	6000	931	2.73	3.66	976	2.89	3.87	1021	3.10	4.16	1064	3.35	4.49	1104	3.56	4.78	1144	3.74	5.02	1185	3.90	5.23

Total Air Volume		TOTAL STATIC PRESSURE - Pa (Inches Water Gauge)																				
		400 (1.60)			450 (1.80)			500 (2.00)			550 (2.20)			600 (2.40)			650 (2.60)					
L/s	cfm	rev/min	kW	BHP	rev/min	kW	BHP	rev/min	kW	BHP	rev/min	kW	BHP	rev/min	kW	BHP	rev/min	kW	BHP	rev/min	kW	BHP
1060	2250	985	1.17	1.57	1034	1.25	1.68	1084	1.34	1.80	1136	1.45	1.95	1189	1.59	2.13	1239	1.73	2.32			
1180	2500	996	1.27	1.70	1045	1.36	1.82	1095	1.46	1.96	1147	1.59	2.13	1201	1.72	2.31	1253	1.88	2.52			
1300	2750	1008	1.37	1.84	1056	1.48	1.98	1105	1.59	2.13	1158	1.72	2.31	1213	1.88	2.52	1266	2.04	2.73			
1415	3000	1019	1.48	1.99	1066	1.60	2.15	1115	1.73	2.32	1169	1.87	2.51	1225	2.04	2.73	1279	2.21	2.96			
1535	3250	1030	1.61	2.16	1076	1.74	2.33	1126	1.88	2.52	1181	2.04	2.73	1237	2.20	2.95	1293	2.38	3.19			
1650	3500	1041	1.75	2.35	1087	1.89	2.53	1138	2.04	2.73	1193	2.20	2.95	1250	2.38	3.19	1307	2.56	3.43			
1770	3750	1053	1.90	2.55	1098	2.05	2.75	1150	2.21	2.96	1207	2.39	3.20	1264	2.57	3.44	1321	2.75	3.69			
1890	4000	1065	2.07	2.78	1111	2.23	2.99	1164	2.40	3.22	1221	2.58	3.46	1279	2.76	3.70	1336	2.95	3.96			
2005	4250	1079	2.25	3.02	1126	2.42	3.25	1180	2.60	3.49	1236	2.78	3.73	1295	2.97	3.98	1352	3.16	4.24			
2125	4500	1094	2.46	3.30	1142	2.63	3.53	1196	2.81	3.77	1253	3.00	4.02	1311	3.18	4.27	1369	3.38	4.53			
2240	4750	1112	2.68	3.60	1161	2.86	3.84	1215	3.04	4.08	1271	3.22	4.32	1329	3.41	4.57	1387	3.60	4.83			
2360	5000	1131	2.93	3.93	1181	3.10	4.16	1235	3.28	4.40	1291	3.46	4.64	1349	3.65	4.89	1406	3.83	5.14			
2480	5250	1153	3.18	4.27	1203	3.36	4.51	1256	3.53	4.74	1312	3.71	4.98	1369	3.89	5.22	1426	4.08	5.47			
2595	5500	1177	3.46	4.64	1226	3.63	4.87	1278	3.80	5.09	1333	3.97	5.32	1390	4.15	5.56	---	---	---			
2715	5750	1202	3.75	5.03	1251	3.91	5.24	1302	4.07	5.46	1356	4.24	5.68	---	---	---	---	---	---			
2830	6000	1229	4.05	5.43	1276	4.20	5.63	---	---	---	---	---	---	---	---	---	---	---	---			

BLOWER DATA

FACTORY INSTALLED BELT DRIVE KIT SPECIFICATIONS

Nominal		Maximum		Drive Kit Number	rev/min Range
kW	hp	kW	hp		
1.5	2	1.7	2.3	1	490 - 740
1.5	2	1.7	2.3	2	665 - 920
1.5	2	1.7	2.3	3	660 - 995
2.2	3	2.6	3.45	7	610 - 810
2.2	3	2.6	3.45	8	780 - 1000
2.2	3	2.6	3.45	9	845 - 1085
3.7	5	4.3	5.75	10	750 - 945
3.7	5	4.3	5.75	11	865 - 1095
3.7	5	4.3	5.75	12	940 - 1190

NOTE - Using total air volume and system static pressure requirements determine from blower performance tables rev/min and motor output required. Maximum usable output of motors furnished are shown. If motors of comparable output are used, be sure to keep within the service factor limitations outlined on the motor nameplate.

POWER EXHAUST FAN PERFORMANCE

Return Air System Static Pressure		Air Volume Exhausted	
Pa	in. w.g.	L/s	cfm
0	0	1498	3175
12	0.05	1394	2955
25	0.10	1267	2685
37	0.15	1137	2410
50	0.20	1022	2165
62	0.25	906	1920
75	0.30	670	1420
87	0.35	566	1200

FACTORY INSTALLED OPTIONS/FIELD INSTALLED ACCESSORY AIR RESISTANCE

Air Volume		Wet Indoor Coil		Dry Indoor Coil		Gas Heat Exchanger						Economizer		Humiditrol Condenser Reheat Coil		Filters				Return Air Adaptor Plate			
		092, 102, 120	150	150	Standard Heat	Medium Heat	High Heat	MERV 8	MERV 13														
L/s	cfm	Pa	in. w.g.	Pa	in. w.g.	Pa	in. w.g.	Pa	in. w.g.	Pa	in. w.g.	Pa	in. w.g.	Pa	in. w.g.	Pa	in. w.g.	Pa	in. w.g.	Pa	in. w.g.	Pa	in. w.g.
1062	2250	32	0.13	45	0.18	30	0.12	17	0.07	17	0.07	20	0.08	20	0.08	5	0.02	2	0.01	10	0.04	0	0.00
1180	2500	37	0.15	55	0.22	35	0.14	22	0.09	25	0.10	27	0.11	27	0.11	7	0.03	2	0.01	12	0.05	0	0.00
1298	2750	42	0.17	57	0.23	37	0.15	22	0.09	27	0.11	30	0.12	30	0.12	7	0.03	5	0.02	12	0.05	0	0.00
1416	3000	47	0.19	70	0.28	45	0.18	27	0.11	30	0.12	32	0.13	32	0.13	7	0.03	5	0.02	15	0.06	5	0.02
1534	3250	57	0.23	82	0.33	52	0.21	30	0.12	37	0.15	40	0.16	37	0.15	10	0.04	5	0.02	15	0.06	5	0.02
1652	3500	65	0.26	92	0.37	57	0.23	30	0.12	40	0.16	42	0.17	37	0.15	10	0.04	7	0.03	17	0.07	10	0.04
1770	3750	72	0.29	104	0.42	65	0.26	35	0.14	47	0.19	50	0.20	37	0.15	12	0.05	7	0.03	20	0.08	17	0.07
1888	4000	77	0.31	112	0.45	70	0.28	35	0.14	52	0.21	55	0.22	47	0.19	12	0.05	10	0.04	20	0.08	22	0.09
2006	4250	85	0.34	124	0.50	80	0.32	35	0.14	60	0.24	70	0.28	47	0.19	15	0.06	10	0.04	22	0.09	27	0.11
2124	4500	92	0.37	132	0.53	82	0.33	37	0.15	65	0.26	80	0.32	55	0.22	17	0.07	10	0.04	22	0.09	30	0.12
2242	4750	99	0.40	147	0.59	92	0.37	40	0.16	72	0.29	92	0.37	62	0.25	17	0.07	12	0.05	25	0.10	40	0.16
2360	5000	107	0.43	157	0.63	99	0.40	40	0.16	85	0.34	107	0.43	72	0.29	20	0.08	15	0.06	25	0.10	45	0.18
2477	5250	114	0.46	169	0.68	104	0.42	40	0.16	92	0.37	117	0.47	80	0.32	20	0.08	15	0.06	27	0.11	47	0.19
2595	5500	124	0.50	182	0.73	114	0.46	45	0.18	109	0.44	134	0.54	85	0.34	22	0.09	17	0.07	30	0.12	55	0.22
2713	5750	139	0.56	196	0.79	124	0.50	47	0.19	122	0.49	147	0.59	112	0.45	25	0.10	17	0.07	30	0.12	62	0.25
2831	6000	147	0.59	214	0.86	134	0.54	50	0.20	134	0.54	159	0.64	129	0.52	25	0.10	20	0.08	32	0.13	67	0.27

BLOWER DATA

CEILING DIFFUSERS AIR RESISTANCE

Unit Size	RTD11 Step-Down Diffuser								FD11 Flush Diffuser	
	Air Volume		2 Ends Open		1 Side, 2 Ends Open		All Ends & Sides Open			
	Pa	in. w.g.	Pa	in. w.g.	Pa	in. w.g.	Pa	in. w.g.	Pa	in. w.g.
092 Models	1133	2400	52	0.21	45	0.18	37	0.15	35	0.14
	1227	2600	60	0.24	52	0.21	45	0.18	42	0.17
	1321	2800	67	0.27	60	0.24	52	0.21	50	0.20
	1416	3000	80	0.32	72	0.29	62	0.25	62	0.25
	1510	3200	102	0.41	92	0.37	80	0.32	77	0.31
	1604	3400	124	0.50	112	0.45	97	0.39	92	0.37
	1699	3600	152	0.61	134	0.54	119	0.48	109	0.44
	1793	3800	182	0.73	157	0.63	142	0.57	127	0.51
102 & 120 Models	1699	3600	90	0.36	70	0.28	57	0.23	37	0.15
	1793	3800	99	0.40	80	0.32	65	0.26	45	0.18
	1888	4000	109	0.44	90	0.36	72	0.29	52	0.21
	1982	4200	122	0.49	99	0.40	82	0.33	60	0.24
	2076	4400	134	0.54	109	0.44	92	0.37	67	0.27
	2171	4600	149	0.60	122	0.49	104	0.42	77	0.31
	2265	4800	162	0.65	132	0.53	114	0.46	87	0.35
	2360	5000	172	0.69	144	0.58	124	0.50	97	0.39
150 Models	2454	5200	186	0.75	154	0.62	134	0.54	107	0.43
	1982	4200	55	0.22	47	0.19	40	0.16	25	0.10
	2076	4400	70	0.28	60	0.24	50	0.20	30	0.12
	2171	4600	85	0.34	72	0.29	60	0.24	37	0.15
	2265	4800	99	0.40	85	0.34	72	0.29	47	0.19
	2360	5000	114	0.46	97	0.39	85	0.34	57	0.23
	2454	5200	129	0.52	109	0.44	97	0.39	67	0.27
	2548	5400	144	0.58	122	0.49	107	0.43	77	0.31
2643	5600	159	0.64	134	0.54	117	0.47	87	0.35	
2737	5800	174	0.70	147	0.59	127	0.51	97	0.39	

CEILING DIFFUSER AIR THROW DATA

Model No.	Air Volume		¹ Effective Throw Range			
			RTD11 Step-Down		FD11 Flush	
	L/s	cfm	m	ft.	m	ft.
092 Models	1227	2600	7 - 9	24 - 29	6 - 7	19 - 24
	1321	2800	8 - 9	25 - 30	6 - 9	20 - 28
	1416	3000	8 - 10	27 - 33	6 - 9	21 - 29
	1510	3200	9 - 11	28 - 35	7 - 9	22 - 29
	1604	3400	9 - 11	30 - 37	7 - 9	22 - 30
102, 120 Models	1699	3600	8 - 10	25 - 33	7 - 9	22 - 29
	1793	3800	8 - 11	27 - 35	7 - 9	22 - 30
	1888	4000	9 - 11	29 - 37	7 - 10	24 - 33
	1982	4200	10 - 12	32 - 40	8 - 11	26 - 35
	2076	4400	10 - 13	34 - 42	9 - 11	28 - 37
150 Models	2643	5600	12 - 15	39 - 49	9 - 11	28 - 37
	2737	5800	13 - 16	42 - 51	9 - 12	29 - 38
	2831	6000	13 - 17	44 - 54	12 - 15	40 - 50
	2926	6200	14 - 17	45 - 55	13 - 16	42 - 51
	3020	6400	14 - 17	46 - 55	13 - 16	43 - 52
3115	6600	14 - 17	47 - 56	14 - 17	45 - 56	

¹ Throw is the horizontal or vertical distance an air stream travels on leaving the outlet or diffuser before the maximum velocity is reduced to 15 m (50 ft.) per minute. Four sides open.

ELECTRICAL DATA

Model No.		LGH092H4			LGH102H4			LGH120H4			LGH150H4		
¹ Voltage - 50hz 3 Phase with neutral		380/420V			380/420V			380/420V			380/420V		
Compressor 1	Rated Load Amps	6.1			6.1			7.8			8		
	Locked Rotor Amps	41			43			51.5			67.1		
Compressor 2	Rated Load Amps	6.1			6.1			7.8			10.6		
	Locked Rotor Amps	41			43			51.5			74		
Outdoor Fan Motors (2)	Full Load Amps	1.3			1.3			1.3			1.5		
	(total)	(2.6)			(2.6)			(2.6)			(3)		
Power Exhaust (1) 0.25 kW (0.33 HP)	Full Load Amps	1.3			1.3			1.3			1.3		
Indoor Blower Motor	kW	1.5	2.2	3.7	1.5	2.2	3.7	1.5	2.2	3.7	1.5	2.2	3.7
	Full Load Amps	3.5	5	7.8	3.5	5	7.8	3.5	5	7.8	3.5	5	7.8
² Maximum Overcurrent Protection	Unit Only	25	25	30	25	25	30	30	30	35	35	40	40
	With 0.25 kW (1) 0.33 HP Power Exhaust	25	25	30	25	25	30	30	30	35	35	40	40
³ Minimum Circuit Ampacity	Unit Only	20	22	26	20	22	26	24	26	28	28	30	33
	With 0.25 kW (1) 0.33 HP Power Exhaust	22	23	27	22	23	27	25	27	30	30	31	34

¹ Extremes of operating range are plus and minus 10% of line voltage.

² Heating/Air Conditioning/Refrigeration (HACR) type breaker or fuse.

³ Refer to local codes manual to determine wire, fuse and disconnect size requirements.

UNIT CLEARANCES

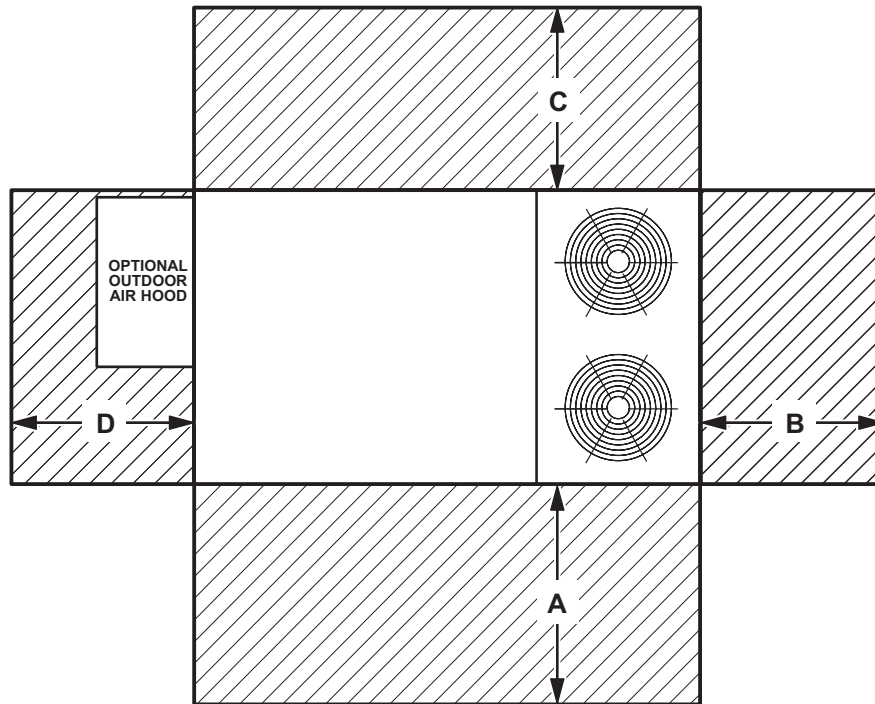

¹ Unit Clearance	A		B		C		D		Top Clearance
	mm	in.	mm	in.	mm	in.	mm	in.	
Service Clearance	1524	60	914	36	914	36	1524	60	Unobstructed
Clearance to Combustibles	914	36	25	1	25	1	25	1	
Minimum Operation Clearance	914	36	914	36	914	36	914	36	

NOTE - Entire perimeter of unit base requires support when elevated above the mounting surface.

¹ **Service Clearance** - Required for removal of serviceable parts.

Clearance to Combustibles - Required clearance to combustible material.

Minimum Operation Clearance - Required clearance for proper unit operation.

OUTDOOR SOUND DATA

Unit Model Number	Octave Band Sound Power Levels dBA, re 10 ⁻¹² Watts Center Frequency - HZ							¹ Sound Rating Number (dBA)
	125	250	500	1000	2000	4000	8000	
092, 102 and 120	76	79	84	83	79	73	66	88
150	75	81	87	85	80	73	67	90

Note - The octave sound power data does not include tonal corrections.

¹ Sound Rating Number according to Air Conditioning, Heating and Refrigeration Institute (AHRI) Standard 370-2001.

WEIGHT DATA

Model Number	Outdoor Coil	Net		Shipping		Outdoor Coil	Net		Shipping	
		kg	lbs.	kg	lbs.		kg	lbs.	kg	lbs.
092 Base Unit	Environ™	494	1088	532	1173	Fin/Tube	530	1168	568	1253
092 Max. Unit	Environ™	562	1239	601	1324	Fin/Tube	598	1319	637	1404
102 Base Unit	Environ™	497	1095	535	1180	Fin/Tube	533	1175	572	1260
102 Max. Unit	Environ™	565	1246	604	1331	Fin/Tube	601	1326	640	1411
120 Base Unit	Environ™	513	1130	551	1215	Fin/Tube	549	1210	587	1295
120 Max. Unit	Environ™	581	1281	620	1366	Fin/Tube	617	1361	656	1446
150 Base Unit	N/A	---	---	---	---	Fin/Tube	567	1250	606	1335
150 Max. Unit	N/A	---	---	---	---	Fin/Tube	635	1401	674	1486

OPTIONS / ACCESSORIES

Model Number	Shipping Weight	
	kg	lbs.

CONVENTIONAL FIN/TUBE CONDENSER COIL

Fin/Tube Condenser Coil	36	80
-------------------------	----	----

ECONOMIZER / OUTDOOR AIR / EXHAUST

Economizer		
Economizer Dampers	27	60
Barometric Relief Dampers (downflow)	10	23
Barometric Relief Damper Hood (downflow)	4	8
Outdoor Air Hood (downflow)	9	20
Outdoor Air Dampers		
Outdoor Air Damper Section (downflow) - Automatic	4	9
Outdoor Air Damper Section (downflow) - Manual	1	2
Outdoor Air Damper Hood (downflow)	4	9
Power Exhaust	14	31

GAS HEAT EXCHANGER (NET WEIGHT)

Medium Heat (adder over standard heat)	5	9
High Heat (adder over standard heat)	15	32

HUMIDITROL® DEHUMIDIFICATION SYSTEM

Humiditrol® Dehumification Option	9	20
-----------------------------------	---	----

ROOF CURBS

Hybrid Roof Curbs, Downflow		
203 mm height	27	60
356 mm height	39	85
457 mm height	45	100
610 mm height	57	125
Adjustable Pitch Curb, Downflow		
356 mm height	82	191

CEILING DIFFUSERS

Step-Down		
RTD11-95S	118	54
RTD11-135S	135	61
RTD11-185S	168	76
Flush		
FD11-95S	118	54
FD11-135S	135	61
FD11-185S	168	76
Transitions		
C1DIFF30B-1	14	30
C1DIFF31B-1	15	32
C1DIFF32B-1	16	36

PACKAGING

LTL Packaging (less than truck load)	48	105
--------------------------------------	----	-----

DIMENSIONS - UNIT

Model No.	CORNER WEIGHTS												CENTER OF GRAVITY											
	AA				BB				CC				DD				EE				FF			
	Base		Max.		Base		Max.		Base		Max.		Base		Max.		Base		Max.		Base		Max.	
	kg	lbs.	kg	lbs.	kg	lbs.	kg	lbs.	kg	lbs.	kg	lbs.	kg	lbs.	kg	lbs.	mm	in.	mm	in.	mm	in.	mm	in.
092	133	293	153	338	119	263	134	295	130	286	143	316	148	326	168	370	1181	46.5	1156	45.5	622	24.5	648	25.5
102	134	294	154	340	120	265	135	297	131	288	144	318	149	328	169	372	1181	46.5	1156	45.5	622	24.5	648	25.5
120	139	306	158	349	125	275	138	305	134	295	148	326	152	334	173	382	1181	46.5	1156	45.5	622	24.5	648	25.5
150	143	316	163	359	129	284	142	314	138	304	393	152	157	345	178	393	1181	46.5	1156	45.5	622	24.5	648	25.5

Base Unit - The unit with NO INTERNAL OPTIONS.

Max. Unit - The unit with ALL INTERNAL OPTIONS Installed. (Economizer, Standard Static Power Exhaust Fans, Controls, etc.). Does not include accessories external to unit or high static power exhaust.

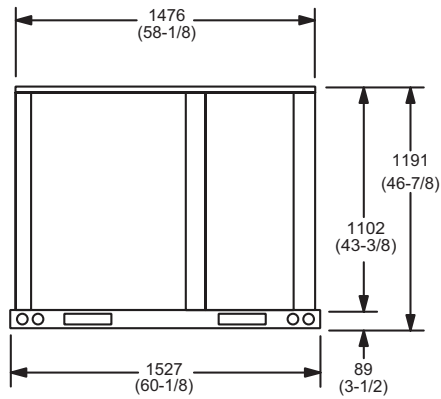
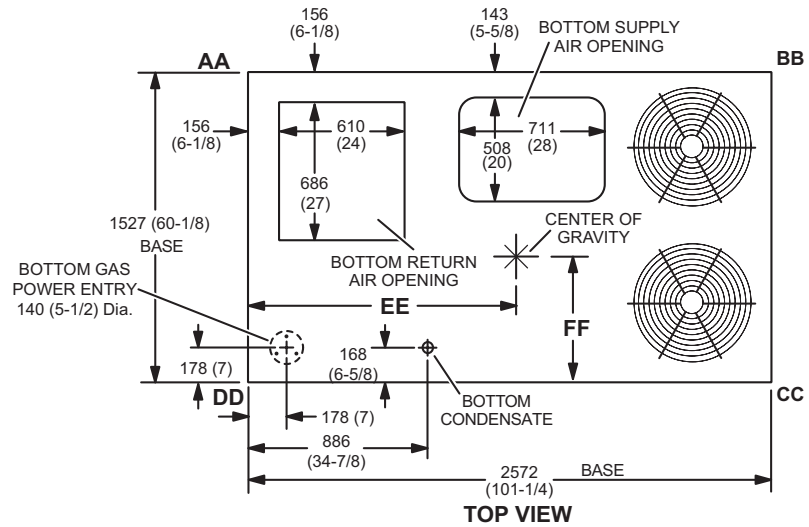

END VIEW

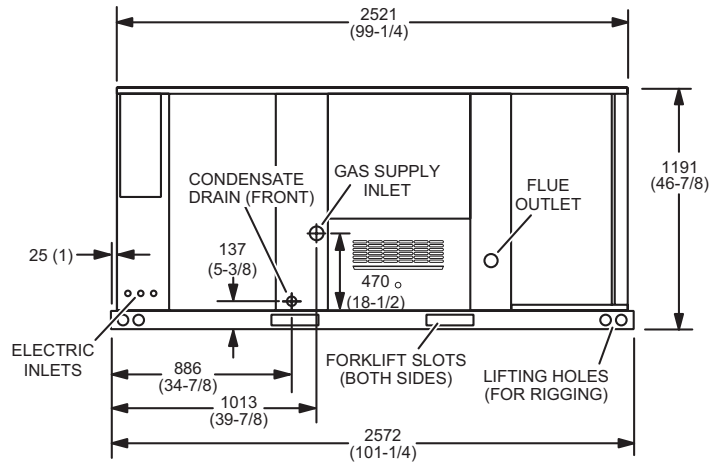

SIDE VIEW

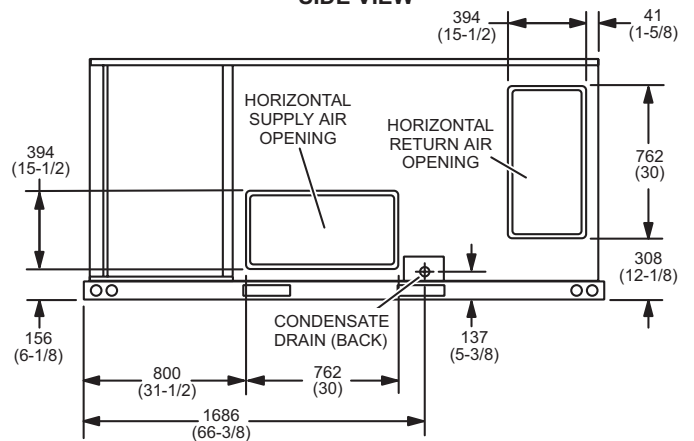

SIDE VIEW
(Horizontal Openings)

OUTDOOR AIR HOOD DETAIL

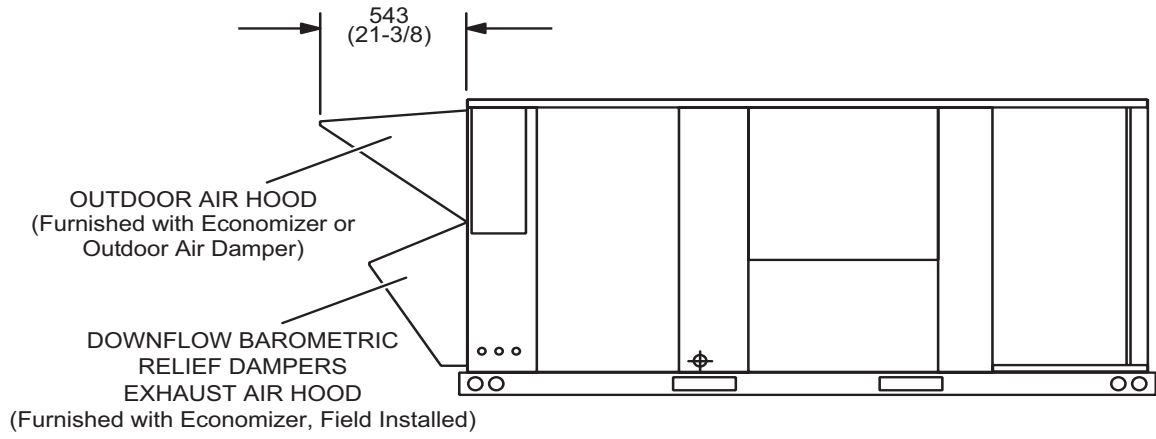

DIMENSIONS - ACCESSORIES

HORIZONTAL ECONOMIZER APPLICATION

(With Furnished Barometric Relief Dampers and Optional Horizontal Discharge Kit - Required)

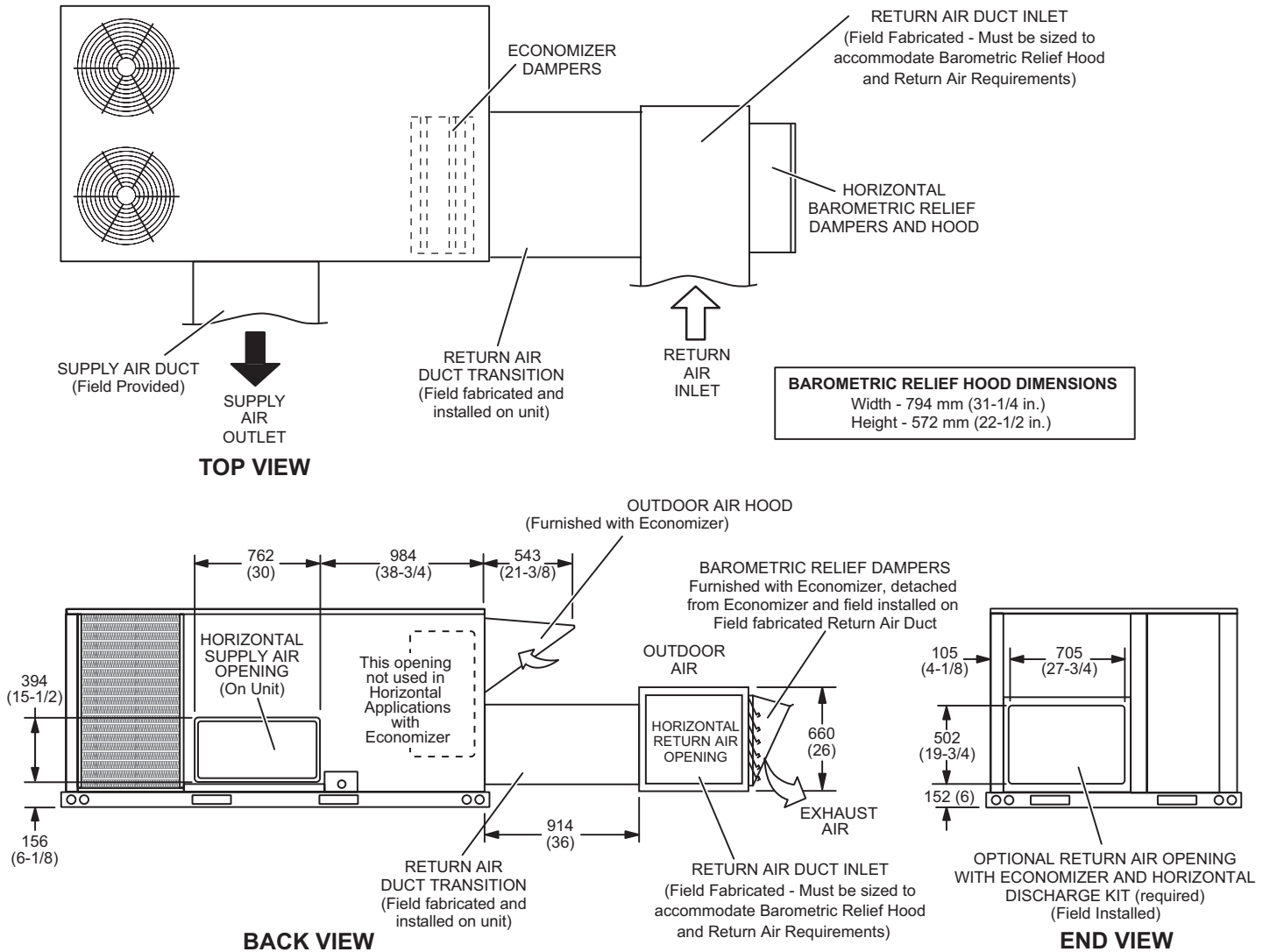

NOTE - Return Air Duct and Transition must be supported.

BAROMETRIC RELIEF DAMPERS (Furnished with Economizer)

(Field installed in horizontal return air duct adjacent to unit)

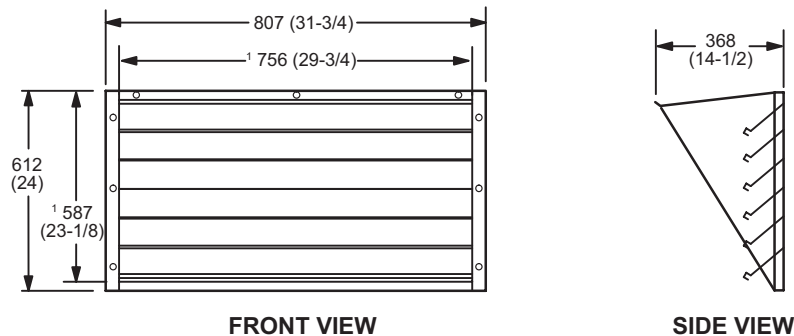

¹ NOTE - Opening size required in return air duct.

DIMENSIONS - ACCESSORIES

HORIZONTAL ECONOMIZER APPLICATION

(with Optional Low Profile Horizontal Barometric Relief Dampers and Horizontal Discharge Kit - Required)

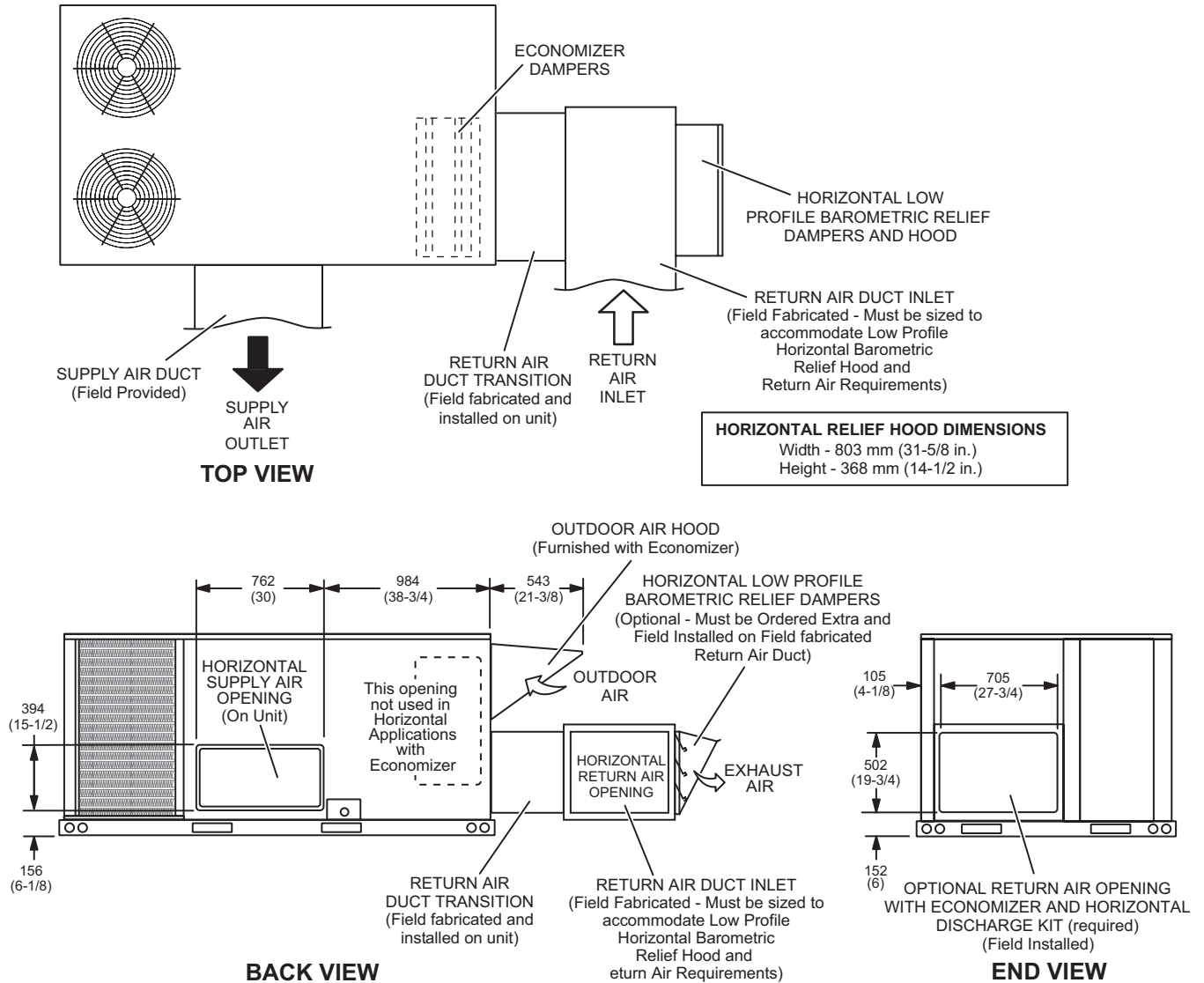

NOTE - Return Air Duct and Transition must be supported.

HORIZONTAL LOW PROFILE BAROMETRIC RELIEF DAMPERS (Field installed in horizontal return air duct adjacent to unit)

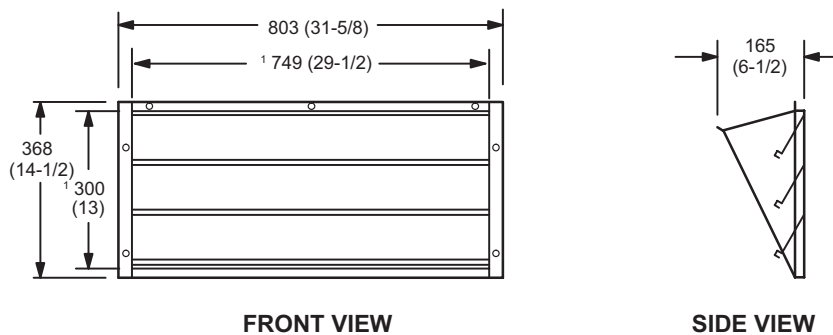

¹ NOTE - Opening size required in return air duct.

DIMENSIONS - ACCESSORIES

HYBRID ROOF CURBS - DOUBLE DUCT OPENING

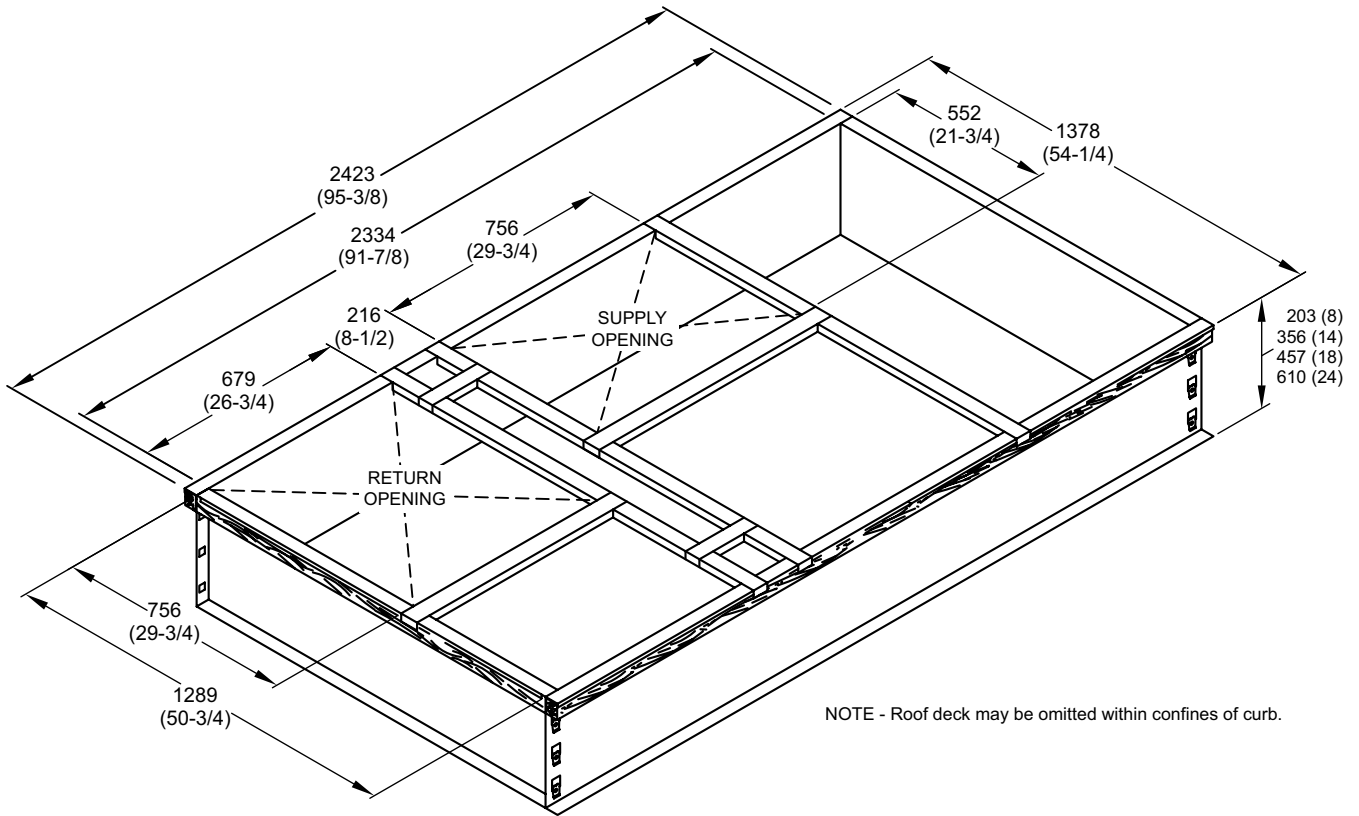

TYPICAL FLASHING DETAIL FOR ROOF CURB

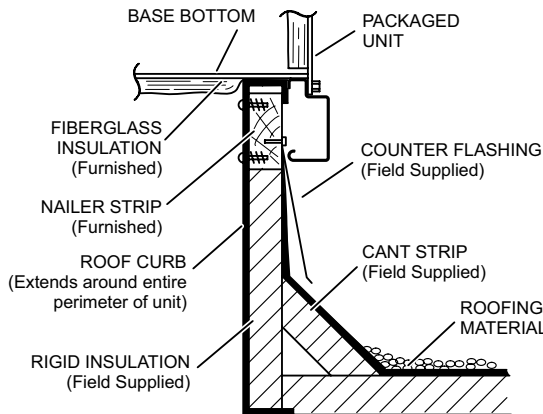

DETAIL ROOF CURB

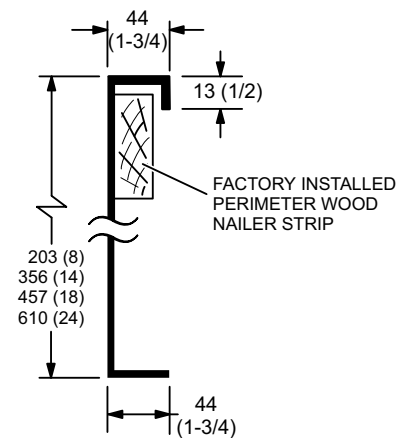

DIMENSIONS - ACCESSORIES

ADJUSTABLE PITCH CURBS - DOUBLE DUCT OPENING

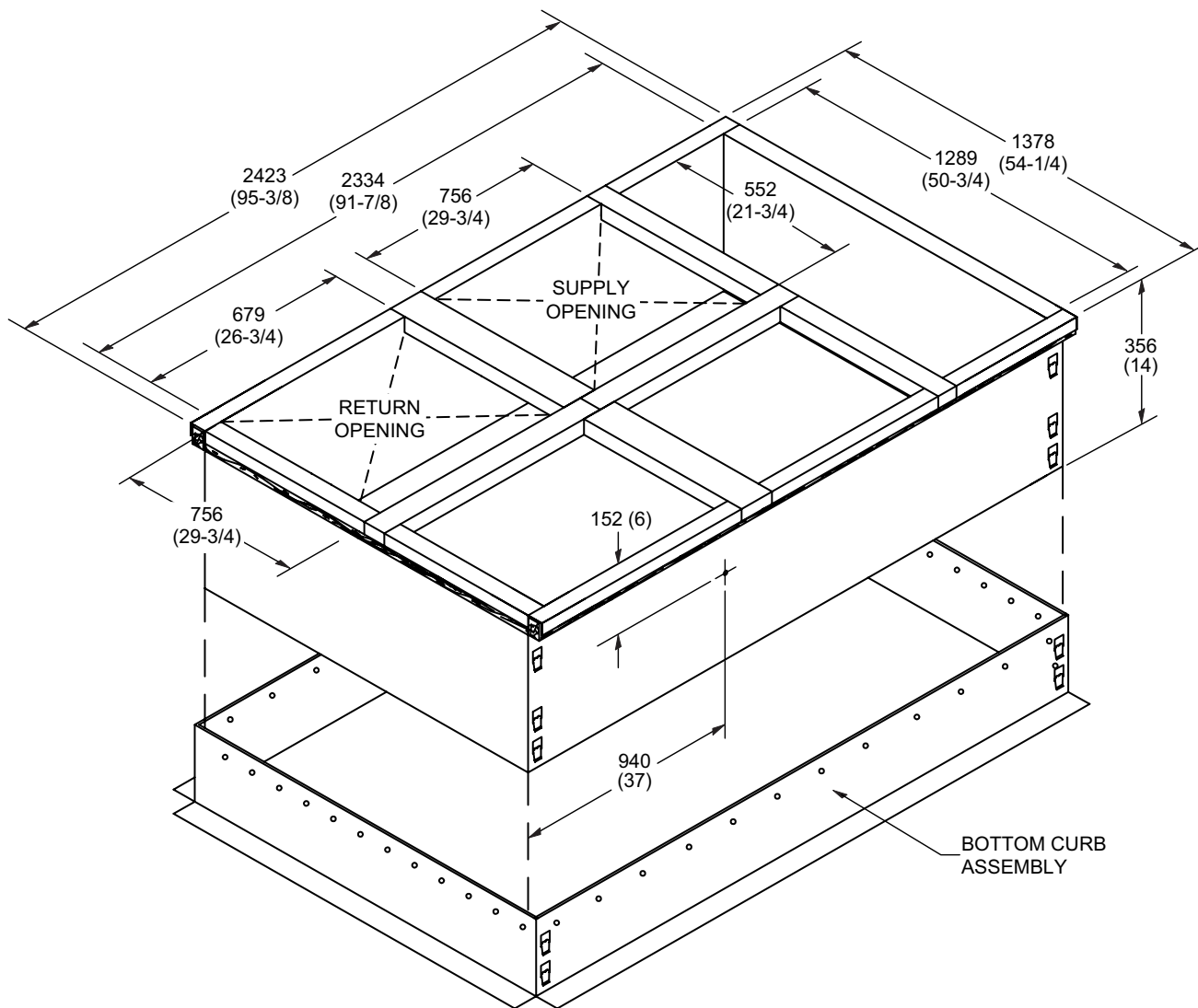

NOTE - Maximum slope pitch is 19 mm per 305 mm (3/4 in. per 1 foot) in any one direction.

TYPICAL FLASHING DETAIL FOR ROOF CURB

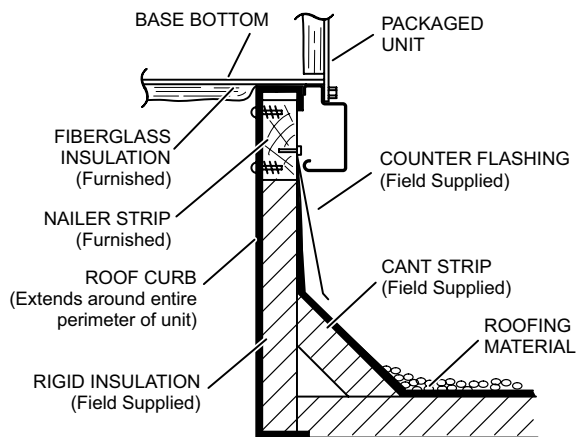

DETAIL ROOF CURB

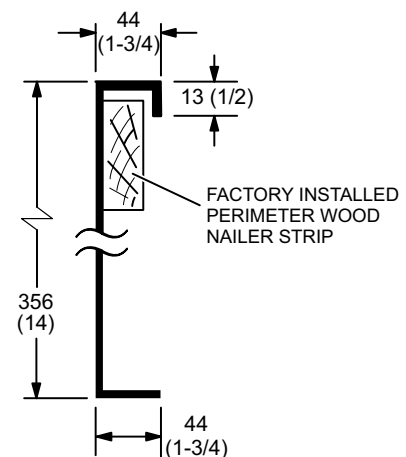

DIMENSIONS - ACCESSORIES

ROOF CURBS WITH SUPPLY & RETURN AIR TRANSITIONS FOR CEILING DIFFUSERS

C1DIFF30B-1 ROUND TRANSITIONS
(for 092 models)

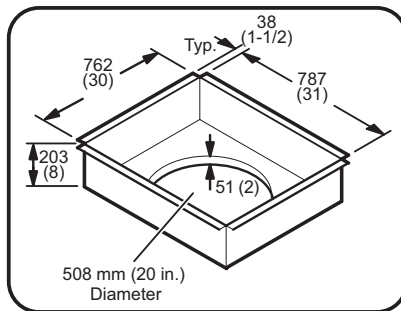

C1DIFF31B-1 & C1DIFF32B-1 RECTANGULAR TRANSITIONS
(for 102 thru 150 models)

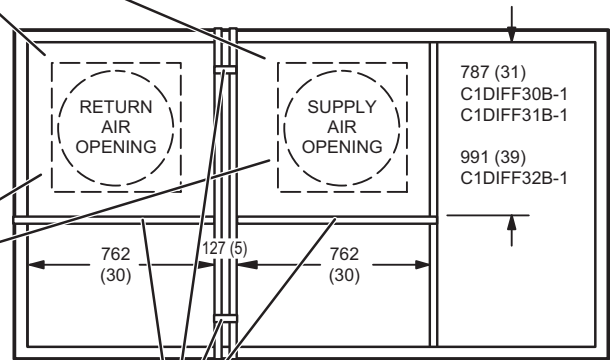
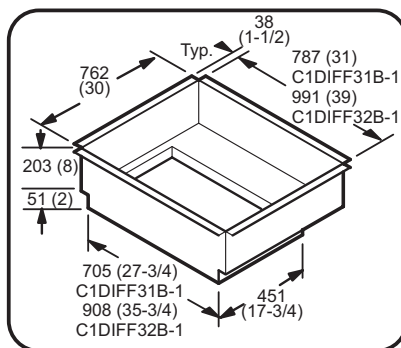

TOP VIEW

NOTE - These four supports are furnished with the transitions to replace supports furnished with curb for proper transition spacing.

DIMENSIONS - ACCESSORIES

COMBINATION CEILING SUPPLY AND RETURN DIFFUSERS

STEP-DOWN CEILING DIFFUSER

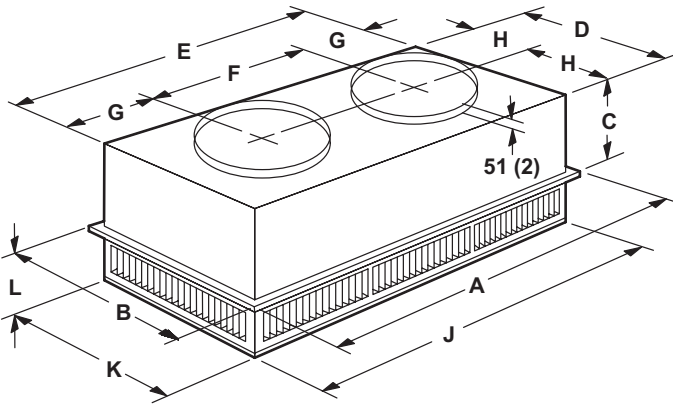

FLUSH CEILING DIFFUSER

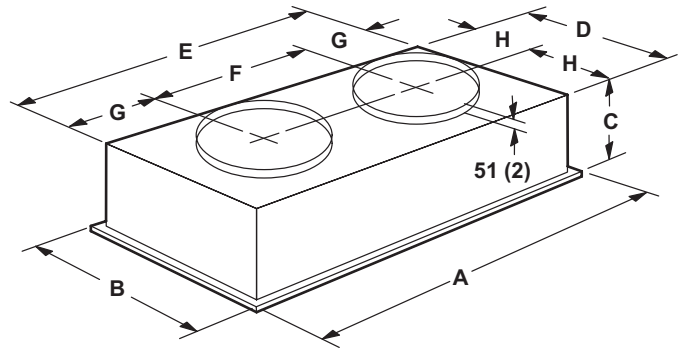

Model Number		RTD11-95S
A	mm	1159
	in.	47-5/8
B	mm	752
	in.	29-5/8
C	mm	365
	in.	14-3/8
D	mm	699
	in.	27-1/2
E	mm	1158
	in.	45-1/2
F	mm	572
	in.	22-1/2
G	mm	292
	in.	11-1/2
H	mm	349
	in.	13-3/4
J	mm	1156
	in.	45-1/2
K	mm	699
	in.	27-1/2
L	mm	206
	in.	8-1/8
Duct Size	mm	508 round
	in.	20 round

Model Number		FD11-95S
A	mm	1159
	in.	47-5/8
B	mm	752
	in.	29-5/8
C	mm	422
	in.	16-5/8
D	mm	686
	in.	27
E	mm	1143
	in.	45
F	mm	22-1/2
	in.	572
G	mm	286
	in.	11-1/4
H	mm	343
	in.	13-1/2
Duct Size	mm	508 round
	in.	20 round

DIMENSIONS - ACCESSORIES

COMBINATION CEILING SUPPLY AND RETURN DIFFUSERS

STEP-DOWN CEILING DIFFUSER

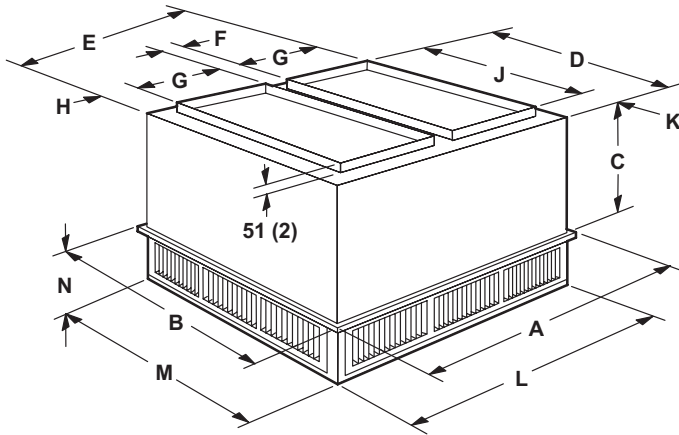

FLUSH CEILING DIFFUSER

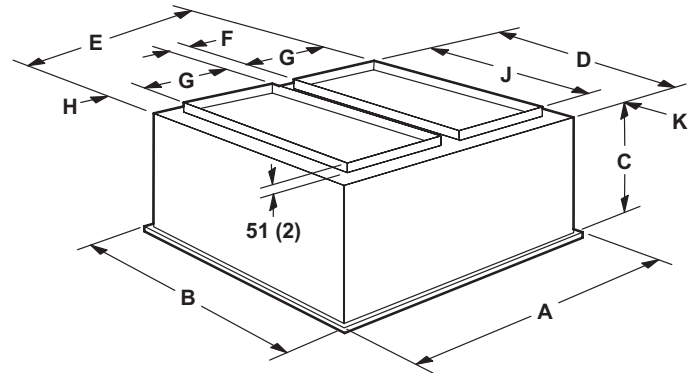

Model Number		RTD11-135S	RTD11-185S
A	mm	1210	1210
	in.	47-5/8	47-5/8
B	mm	905	1210
	in.	35-5/8	47-5/8
C	mm	524	625
	in.	20-5/8	24-5/8
D	mm	851	1156
	in.	33-1/2	45-1/2
E	mm	1156	1156
	in.	45-1/2	45-1/2
F	mm	114	114
	in.	4-1/2	4-1/2
G	mm	457	457
	in.	18	18
H	mm	64	64
	in.	2-1/2	2-1/2
J	mm	711	914
	in.	28	36
K	mm	70	121
	in.	2-3/4	4-3/4
L	mm	1156	1156
	in.	45-1/2	45-1/2
M	mm	851	1156
	in.	33-1/2	45-1/2
N	mm	232	257
	in.	9-1/8	10-1/8
Duct Size	mm	457 x 711	457 x 914
	in.	18 x 28	18 x 36

Model Number		FD11-135S	FD11-185S
A	mm	1210	1210
	in.	47-5/8	47-5/8
B	mm	905	1210
	in.	35-5/8	47-5/8
C	mm	591	743
	in.	23-1/4	29-1/4
D	mm	838	1143
	in.	33	45
E	mm	1143	1143
	in.	45	45
F	mm	112	112
	in.	4-1/2	4-1/2
G	mm	457	457
	in.	18	18
H	mm	57	57
	in.	2-1/4	2-1/4
J	mm	711	914
	in.	28	36
K	mm	64	114
	in.	2-1/2	4-1/2
Duct Size	mm	457 x 711	457 x 914
	in.	18 x 28	18 x 36

REVISIONS

Sections	Description of Change
Options/Accessories	Catalog numbers revised for: Blower Proving Switch Cold Weather Kits Discharge Air Temperature Switch Disconnects Economizers Float Switch Gravity Exhaust Dampers LPG Kits Power Exhaust Single Enthalpy Smoke Detectors



Visit us at www.lennox.com

For the latest technical information, www.lennoxcommercial.com

Contact us at 1-800-4-LENNOX

NOTE - Due to Lennox' ongoing commitment to quality, Specifications, Ratings and Dimensions subject to change without notice and without incurring liability. Improper installation, adjustment, alteration, service or maintenance can cause property damage or personal injury. Installation and service must be performed by a qualified installer and servicing agency.

©2021 Lennox Industries, Inc.