



**COMMERCIAL
PRODUCT SPECIFICATIONS**

Bulletin No. 490179
March 2021
Supersedes March 2019



RAIDER®
Value Without Compromise®



26 to 44 kW (7.5 to 12.5 Tons)
Net Cooling Capacity – 22.5 to 34.5 kW (76 800 to 117 800 Btuh)
Optional Electric Heat - 5.7 to 45.9 kW

MODEL NUMBER IDENTIFICATION

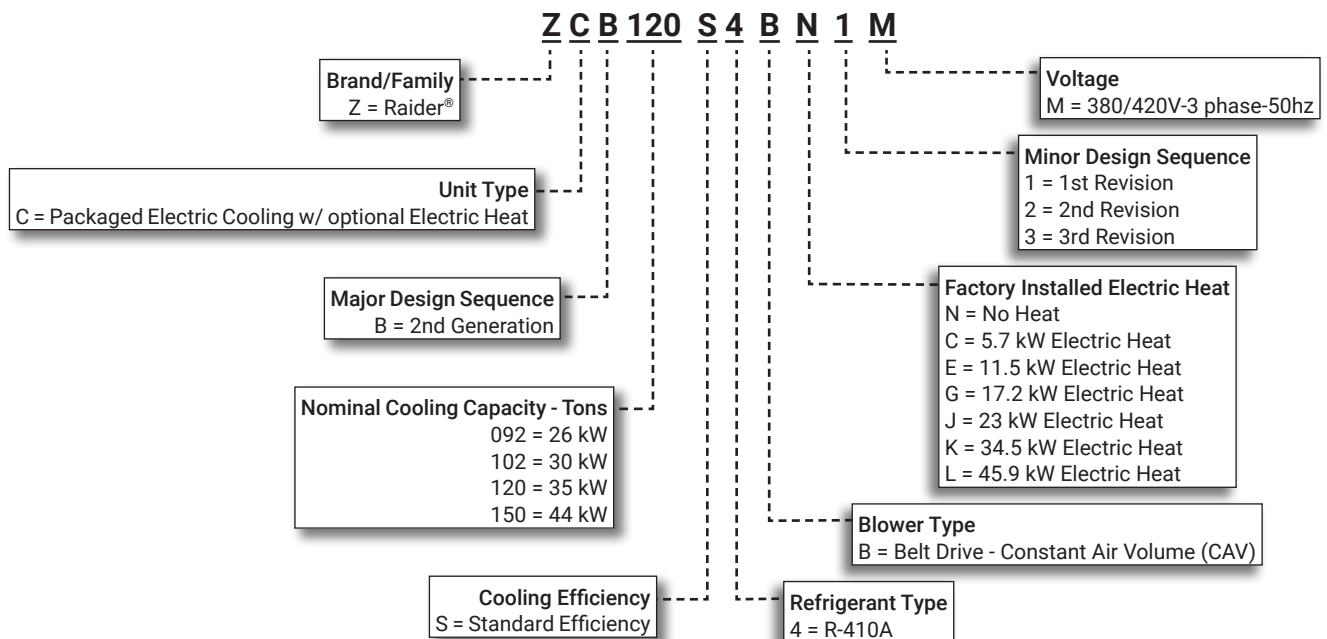

FEATURE HIGHLIGHTS

Raider® rooftop units from Lennox Commercial are the new standard for reliable, efficient rooftop units built for long-lasting performance that can significantly improve indoor environments.

1. Scroll Compressors
2. Lennox' Environ™ Coil System
3. Outdoor Coil Fans
4. Heavy Gauge Steel Cabinet
5. Supply Air Blower
6. Electric Heat (option)

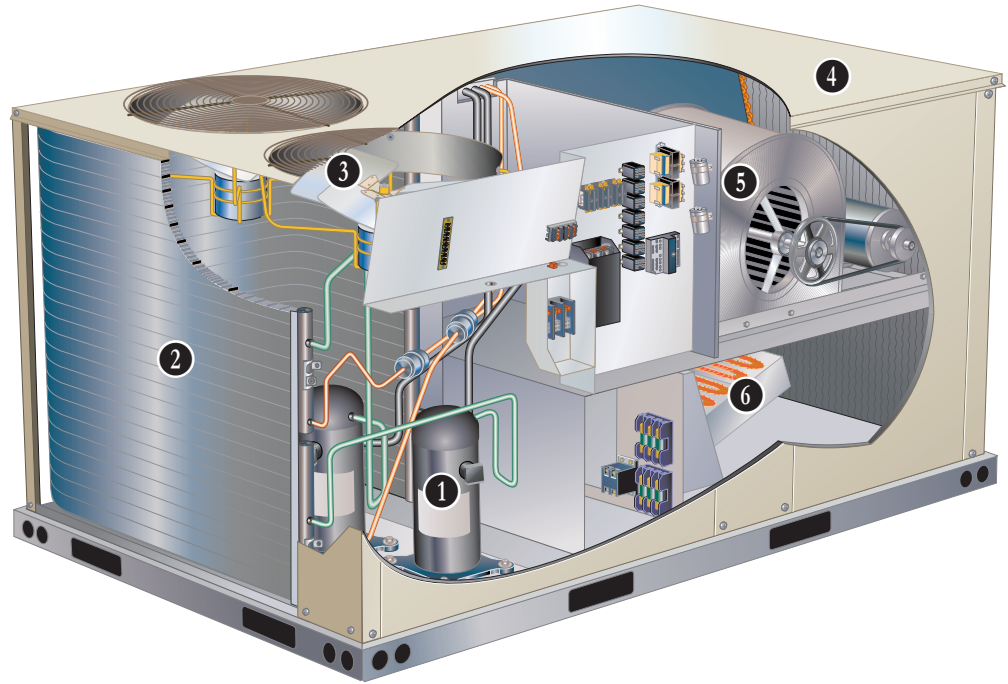

CONTENTS

Blower Data	17
Dimensions - Accessories	28
Dimensions - Unit	27
Electrical/Electric Heat Data	23
Electric Heat Capacities	25
Features And Benefits	3
Model Number Identification.	1
Optional Conventional Temperature Control Systems	8
Options / Accessories	9
Outdoor Sound Data	25
Performance / Quality	3
Ratings.	13
Specifications	12
Unit Clearances	25
Weight Data	26

APPROVALS AND WARRANTY

PERFORMANCE / QUALITY

- Components bonded for grounding to meet safety standards for servicing required by Underwriters Laboratories (UL) and the International Electrotechnical Commission (IEC)
- Cooling performance is rated at test conditions included in Air- Conditioning, Heating and Refrigeration Institute (AHRI) Standard 340/360 while operating at rated voltage and air volumes
- International Organization for Standardization (ISO) 9001 Registered Manufacturing Quality System

FEATURES AND BENEFITS

COOLING SYSTEM

- Designed to maximize sensible and latent cooling performance at design conditions
- System can operate from 4.4°C (10°C for 150 models) to 52°C without any additional controls

R-410A Refrigerant

- Non-chlorine based
- Ozone friendly

1 Scroll Compressors

- Scroll compressors on all models for high performance, reliability and quiet operation
- Resiliently mounted on rubber grommets for quiet operation

Refrigerant Metering Orifice

- Accurately meters refrigerant in system
- Refrigerant control is accomplished by exact sizing of refrigerant metering orifice

Filter/Driers

- High capacity filter/drier protects the system from dirt and moisture

High Pressure Switches

- Protects the compressor from overload conditions such as dirty condenser coils, blocked refrigerant flow, or loss of outdoor fan operation

2 Condenser Coil - Lennox' Environ™ Coil System (092-120 models only)

- Lightweight, all aluminum brazed fin construction
- Constructed of three components:
 - A flat extrusion tube
 - Fins in-between the flat extrusion tube
 - Two refrigerant manifolds

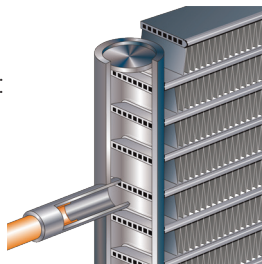

Environ™ Coil System Features:

- Improved heat transfer performance due to high primary surface area (flat tubes) versus secondary surface (fins)
- Smaller internal volume (reduced refrigerant charge)
- High durability (all aluminum construction)
- Fewer brazed joints
- Compact design (reduces unit weight)
- Easy maintenance/cleaning
- Face-split design
- Mounting brackets with rubber inserts

Conventional Fin/Tube Condenser Coils (150 models only)

- Copper tube construction
- Enhanced rippled-edge aluminum fins
- Flared shoulder tubing connections
- Silver soldered construction

Evaporator Coil

- Copper tube construction
- Enhanced rippled-edge aluminum fins
- Flared shoulder tubing connections
- Silver soldered construction
- Factory leak tested
- Cross row circuiting with rifled tubing

Condensate Drain Pan

- Plastic pan, sloped to meet drainage requirements per ASHRAE 62.1
- Side drain connections

Outdoor Coil Fan Motors

- Thermal overload protected
- Totally enclosed
- Permanently lubricated ball bearings
- Shaft up
- Wire basket mount

3 Outdoor Coil Fans

- Polyvinyl Chloride (PVC) coated fan guards

Required Selections

Cooling Capacity

- Specify nominal cooling capacity

FEATURES AND BENEFITS

COOLING SYSTEM (continued)

Options/Accessories

Field Installed

Condensate Drain Trap

- Available in copper or Polyvinyl Chloride (PVC)

Drain Pan Overflow Switch

- Monitors condensate level in drain pan
- Shuts down unit if drain becomes clogged

Low Ambient Kit

(Includes Compressor Crankcase Heater)

- Cycles the outdoor fans while allowing compressor operation in the cooling cycle
- Intermittent fan operation allows the system to operate without icing the evaporator coil and losing capacity
- Designed for use in ambient temperatures no lower than -18°C
- Controls the compressor crankcase heaters

NOTE - Compressor crankcase heater is furnished with the kit and protects against refrigerant migration that can occur during low ambient operation.

CABINET

Construction

- 4 • Heavy-gauge steel panels
- Full perimeter heavy-gauge galvanized steel base rail
- Base rails have rigging holes
- Three sides of the base rail have forklift slots
- Raised edges around duct and power entry openings in the bottom of the unit for water protection

Airflow Choice

- Units are shipped in downflow (vertical) return air flow configuration

NOTE - Units can be field converted to horizontal airflow.

Duct Flanges

- Provided for horizontal duct attachment

Power Entry

- Electrical lines can be brought through the unit base or through horizontal access knock-outs

NOTE - Optional Bottom Power Entry Kit is available.

Exterior Panels

- Constructed of heavy-gauge, galvanized steel
- Two-layer enamel paint finish

Insulation

- Fully insulated with non-hygroscopic fiberglass insulation (conditioned areas)

Access Panels

- Filter section
- Blower/heating section
- Compressor/controls section
- Recessed handles for easy service access

Options/Accessories

Factory Installed

Corrosion Protection

- Completely flexible immersed coating
- Electrodeposited dry film process (AST ElectroFin E-Coat)
- Meets Mil Spec MIL-P-53084, ASTM B117 Standard Method Salt Spray Testing
- Indoor Corrosion Protection
 - Coated coil
- Outdoor Corrosion Protection
 - Coated coil

Field Installed

Combination Coil/Hail Guards

- Heavy gauge steel frame
- Painted to match cabinet
- Expanded metal mesh protects outdoor coil

BLOWER

A wide selection of supply air blower options are available to meet a variety of airflow requirements.

Constant Air Volume Blower (CAV)

- Supply air blower provides a constant volume of air

Motor

- Overload protected
- Ball bearings
- Belt drive motors are offered on all models and are available in several different sizes to maximize air performance

5 Supply Air Blower

- Forward curved blades
- Double inlet
- Blower wheel statically and dynamically balanced
- Ball bearings
- Adjustable pulley (allows speed change)

Required Selections

- Order blower motor output and drive kit number required when base unit is ordered
- See Drive Kit Specifications Table

FEATURES AND BENEFITS

CONTROLS

Unit Control

- All control voltage is provided via a 24V (secondary) transformer with built-in circuit breaker protection
- **Heat/Cool Staging** - Capable of up to 2 heat / 2 cool staging with a third party DDC control system or thermostat
- **Low Voltage Terminal Block** - Provides screw terminal connections for thermostat or controller wiring
- **Night Setback Mode** - Saves energy by closing outdoor air dampers and operating supply fan on thermostat demand only

Options / Accessories

Smoke Detectors

NOTE - Smoke detectors are not available and must be field provided by installer.

Thermostats

- Control system and thermostat options, see page 8

ELECTRICAL

Marked & Color-Coded Wiring

- All electrical wiring is color-coded and marked to identify which components it is connecting

Electrical Plugs

- Positive connection electrical plugs are used to connect common accessories or maintenance parts for easy removal or installation

Required Selections

Voltage Choice

- Specify when ordering base unit

Options/Accessories

Field Installed

6 Electric Heat

- Helix wound nichrome elements, individual element limit controls, wiring harness
- See Options / Accessories tables for ordering information

NOTE - Unit Fuse Block is required and must be ordered separately. See Electrical / Electric Heat tables for ordering information.

Bottom Power Entry Kit

- Kit reduces the number of penetrations in the roof
- Kit includes bulkhead connectors to provides power and control wiring routing through the roof curb

INDOOR AIR QUALITY

Air Filters

- Disposable 51 mm filters furnished as standard

Options/Accessories

Field Installed

Healthy Climate® High Efficiency Air Filters

- Disposable MERV 8 or MERV 13 (Minimum Efficiency Reporting Value based on ASHRAE 52.2 efficiency 51 mm pleated filters)

Replacement Filter Media Kit With Frame

- Replaces existing pleated filter media
- Includes washable metal mesh screen and metal frame with clip for holding replaceable non-pleated filter

Indoor Air Quality (CO₂) Sensors

- Monitors CO₂ levels
- Reports to the Unit Controller which adjusts economizer dampers as needed

OPTIONS / ACCESSORIES

ECONOMIZER

Factory or Field Installed

NOTE - Downflow Economizer is factory or field installed.
Horizontal Economizer is field installed only.

Economizer

(Standard and High Performance Common Features)

- Barometric Relief Dampers allow relief of excess air
- Aluminum blade dampers prevent blow back and outdoor air infiltration during off cycle
- Exhaust hood with bird screen furnished

NOTE - Outdoor Air and Barometric Relief Exhaust Hoods are included when economizer is factory installed and are furnished with economizer when ordered for field installation.

- Occupied/Unoccupied mode with field furnished setback thermostat
- Demand Control Ventilation (DCV) ready using optional CO₂ sensors
- Single temperature control is furnished with Economizer
- Outdoor air temperature sensor enables Economizer if the outdoor temperature is less than the setpoint of the control

Standard Economizer Features

- Downflow or Horizontal models with Barometric Relief Dampers and Hoods
- Parallel, gear-driven action
- Return air and outdoor air dampers
- Plug-in connections to unit
- Nylon bearings
- Neoprene seals
- 24-volt
- Fully-modulating spring return motor

Standard Economizer Control Module

The Standard Economizer Control Module can be adjusted to operate based on outdoor air temperatures.



Economizer Controls:

- **Damper Minimum Position** - Can be set lower than traditional minimum air requirements resulting in cost savings
- **IAQ Sensor** - Signals dampers to modulate and maintain 13°C when CO₂ is higher than the CO₂ setpoint
- **Demand Control Ventilation (DCV) LED** - A steady green Demand Control Ventilation LED indicates the IAQ reading is higher than setpoint and requires more fresh air
- **Free Cool LED** - A steady green LED indicates outdoor air is suitable for free cooling
- Free Cooling runs when outdoor air temperature is lower than the set temperature on the economizer control

NOTE - The Free Cooling default setting for outdoor air temperature sensor is 13°C.

High Performance Economizer Features

- Downflow models with Barometric Relief Dampers and Hoods
- Parallel gear-driven action
- High torque 24-volt fully-modulating spring return damper motor
- Return air and outdoor air dampers
- Plug-in connections to unit
- Stainless steel bearings
- Enhanced thermoplastic vulcanizate (TPV) blade edge seals
- Flexible stainless steel jamb seals to minimize air leakage

High Performance Economizer Control Module

- Module provides inputs and outputs to control economizer based on parameter settings
- Module automatically detects sensors by polling to determine which sensors are installed in system
- Module displays any alarm messages (fault detection and diagnostics) as an aid in troubleshooting
- Non-volatile memory retains parameter settings in case of power failure
- Keypad with four navigation buttons and LCD screen is furnished for setting economizer parameters



- Menu Up/Exit (⬆️) button returns to the main menu
- Arrow Up (▲) button moves to the previous or next parameter within the selected menu
- Arrow Down (▼) button moves to the next parameter within the selected menu
- Select (enter) (↵) button confirms parameter selection

Main Menu Structure:

- STATUS (economizer and system operation status)
- SETPOINTS (settings for various setpoint parameters)
- SYSTEM SETUP (settings/information about the system)
- ADVANCED SETUP (freeze protection, CO₂ settings, stage 3 delay, and additional calibration settings)
- CHECKOUT (damper positions)
- ALARMS (output signal that can be configured for remote alarm monitoring)

NOTE - Refer to Installation Instructions for complete setup information and menu parameters available.

Field Installed

Single Enthalpy Temperature Control

- Outdoor air enthalpy sensor enables economizer if the outdoor enthalpy is less than the setpoint of the control

Differential Enthalpy Control

- Order two Single Enthalpy Control Kits
- One is field installed in the return air section, the other in the outdoor air section
- Allows the economizer control board to select between outdoor air or return air, whichever has lower enthalpy

OPTIONS / ACCESSORIES

EXHAUST

Field Installed

Horizontal Low Profile Barometric Relief Dampers

- For use when unit is configured for horizontal applications in a reduced space requiring an economizer
- Allows relief of excess air
- Aluminum blade dampers prevent blow back and outdoor air infiltration during off cycle
- Field installed in return air duct
- Exhaust hood with bird screen furnished

Power Exhaust Fan

- Installs internal to unit for downflow applications only with Economizer option
- Provides exhaust air pressure relief
- Interlocked to run when supply air blower is operating
- Fan runs when outdoor air dampers are 50% open (adjustable)
- Motor is overload protected
- Fan is 508 mm diameter
- Five blades (K1PWRE10B)
- One 0.25 kW motor

NOTE - Requires Economizer with Outdoor Air Hood and Barometric Relief Dampers.

OUTDOOR AIR

Field Installed

Outdoor Air Damper

- Downflow or Horizontal With Air Hood
- Linked mechanical dampers
- 0 to 25% (fixed) outdoor air adjustable
- Installs in unit
- Includes outdoor air hood
- Automatic model features fully modulating spring return damper motor with plug-in connection
- Manual model features a slide damper

NOTE - Maximum mixed air temperature in cooling mode: 38°C.

ROOF CURBS

Field Installed

Hybrid Roof Curbs, Downflow

- Nailer strip furnished, mates to unit
- US National Roofing Contractors approved
- Shipped knocked down
- Interlocking tabs fasten corners together, no tools required
- Can also be fastened together with furnished hardware
- Available in 203, 356, 457 and 610 mm heights

CEILING DIFFUSERS

Field Installed

Ceiling Diffusers (Flush or Step-Down)

- White powder coat finish on diffuser face and grilles
- Insulated UL listed duct liner
- Diffuser box has collars for duct connection
- Step-down diffusers have double deflection blades
- Flush diffusers have fixed blades
- Provisions for suspending
- Internally sealed to prevent recirculation
- Removable return air grille
- Adapts to T-bar ceiling grids or plaster ceilings

Transitions (Supply and Return)

NOTE - Ceiling Diffuser Transitions are not furnished and must be field fabricated.

OPTIONAL CONVENTIONAL TEMPERATURE CONTROL SYSTEMS

ComfortSense® 7500 Commercial 7-Day Programmable Thermostat



- Four-Stage Heating / Two-Stage Cooling
- Universal Multi-Stage
- Intuitive Touchscreen Interface
- Automatic Changeover between Heating and Cooling
- Full Seven-Day Programming
- Four Time Periods Per Day
- Temperature and Humidity Control
- One-Touch Away Mode
- Holiday Scheduling
- Smooth Setback Recovery (SSR)
- Performance Reports
- Notifications/Reminders
- Economizer Relay Control
- Backlit Display
- Wallplate Furnished
- FDD, ASHRAE and IECC Compliant

ComfortSense® 3000 Commercial 5-2 Day Programmable Thermostat



- Two-Stage Heating / Two-Stage Cooling
- Conventional Systems
- Intuitive Interface
- 5-2 Day Programming
- Program Hold
- Remote Indoor Temperature Sensing
- Smooth Setback Recovery (SSR)
- Economizer Relay Control
- Maintenance/Filter/Service Reminders
- Backlit Display
- Wallplate Furnished
- Simple Up and Down Temperature Control

Bacnet Compatible Thermostat With Reheat Function



- 7-Day Programmable
- BTL listed MS/TP ensures compatibility with any BACnet system
- Built-in control programs for conventional and heat pump applications
- Conventional systems up to 3-stage heat and 3-stage cool
- Heat pumps with 1 or 2 compressors and up to 2-stage auxiliary heat
- On-board temperature and humidity sensor
- Multiple configurable inputs and outputs enable advanced control strategies
- Set-up Wizard enables rapid system configuration
- No special tools required for installation or commissioning
- Seven-day (2, 4 or 6 event) occupancy scheduling per day
- Backlit 5-inch LCD touchscreen

Description	Model No.	Catalog No.
ComfortSense® 7500 7-Day Programmable	C0STAT06FF2L	17G74
Universal thermostat locking guard (clear)	C0MISC15AE1-	39P21
Temperature Sensors	1 Remote non-adjustable wall-mount 20k	47W36
	1 Remote non-adjustable wall-mount 10k	47W37
	Remote non-adjustable discharge air (duct mount)	19L22
	Outdoor temperature sensor	X2658
¹ Remote wall-mount sensors can be applied in any of the following combinations: One Sensor - (1) 47W36 Two Sensors - (2) 47W37 Three Sensors - (2) 47W36 and (1) 47W37 Four Sensors - (4) 47W36 Five Sensors - (3) 47W36 and (2) 47W37		
ComfortSense® 3000 5-2 Day Programmable	C0STAT05FF1L	11Y05
Thermostat wall mounting plate	C0MISC17AE1-	X2659
Temperature Sensor	Remote non-adjustable wall mount 10k averaging	47W37
7-Day Programmable - Bacnet Compatible	- - -	Y8241
BACnet Controls	BACnet® Module (factory or field installed)	K0CTRL31B-2 16X71
	BACnet® Room Sensor with Display (field)	K0SNSR01FF1 97W23
	BACnet® Room Sensor without Display (field)	K0SNSR00FF1 97W24

OPTIONS / ACCESSORIES

Item Description	Model Number	Catalog Number	Unit Model No			
			092	102	120	150
COOLING SYSTEM						
Condensate Drain Trap	Polyvinyl Chloride (PVC) - C1TRAP20AD2	22H54	X	X	X	X
	Copper - C1TRAP10AD2	76W27	X	X	X	X
Corrosion Protection		Factory	O	O	O	O
Drain Pan Overflow Switch	Z1SNSR90A1	99W59	X	X	X	X
Low Ambient Kit (Includes Compressor Crankcase Heater)	380/420V-3ph - Z1LOAM02B-1G	10Z36	X	X		
	380/420V-3ph - Z1LOAM12B-1G	10Z51			X	X
Refrigerant Type		R-410A	O	O	O	O
BLOWER - SUPPLY AIR						
Blower Motors	Belt Drive - 1.5 kW	Factory	O	O	O	O
	Belt Drive - 2.2 kW	Factory	O	O	O	O
	Belt Drive - 3.7 kW	Factory	O	O	O	O
Drive Kits	Kit #1 490-740 rev/min	Factory	O	O	O	O
See Blower Data Tables for selection	Kit #2 665-920 rev/min	Factory	O	O	O	O
	Kit #3 660-995 rev/min	Factory	O	O	O	O
	Kit #7 610-810 rev/min	Factory	O	O	O	O
	Kit #8 780-1000 rev/min	Factory	O	O	O	O
	Kit #9 845-1085 rev/min	Factory	O	O	O	O
	Kit #10 750-945 rev/min	Factory	O	O	O	O
	Kit #11 865-1095 rev/min	Factory	O	O	O	O
	Kit #12 940-1190 rev/min	Factory	O	O	O	O
	CABINET					
	Combination Coil/Hail Guards	Z1GARD52B-1	12X21	X	X	X
INDOOR AIR QUALITY						
Air Filters						
Healthy Climate® High Efficiency Air Filters 208 x 610 x 51 mm (Order 4 per unit)	MERV 8 - Z1FLTR15B-1	14C35	X	X	X	X
	MERV 13 - Z1FLTR40B-1	14C36	X	X	X	X
Replacement Media Filter With Metal Mesh Frame (includes non-pleated filter media)	C1FLTR30B-1-	Y3063	X	X	X	X
Indoor Air Quality (CO₂) Sensors						
Sensor - Wall-mount, off-white plastic cover with LCD display	C0SNSR50AE1L	77N39	X	X	X	X
Sensor - Wall-mount, off-white plastic cover, no display	C0SNSR52AE1L	87N53	X	X	X	X
Sensor - Black plastic case with LCD display, rated for plenum mounting	C0SNSR51AE1L	87N52	X	X	X	X
Sensor - Wall-mount, black plastic case, no display, rated for plenum mounting	C0MISC19AE1	87N54	X	X	X	X
CO ₂ Sensor Duct Mounting Kit - for downflow applications	C0MISC19AE1-	85L43	X	X	X	X
Aspiration Box - for duct mounting non-plenum rated CO ₂ sensors (87N53 or 77N39)	C0MISC16AE1-	90N43	X	X	X	X
ELECTRICAL						
Voltage 50 Hz with neutral	380/420V - 3 phase	Factory	O	O	O	O
Bottom Power Entry Kit	Z1PEKT01B-1	11H66	X	X	X	X

NOTE - Catalog and model numbers shown are for ordering field installed accessories.

OX - Configure To Order (Factory Installed) or Field Installed

O = Configure To Order (Factory Installed)

X = Field Installed

OPTIONS / ACCESSORIES

Item Description	Model Number	Catalog Number	Unit Model No			
			092	102	120	150
¹ ELECTRIC HEAT						
5.7 kW	380/420V-3ph - Z1EH0075B-1G	10Y98	X	X		
11.5 kW	380/420V-3ph - Z1EH0150B-1G	10Z03	X	X	X	X
17.2 kW	380/420V-3ph - Z1EH0225B-1G	10Z06	X	X	X	X
23 kW	380/420V-3ph - Z1EH0300B-1G	10Z09	X	X	X	X
34.5 kW	380/420V-3ph - Z1EH0450B-1G	10Z12	X	X	X	X
45.9 kW	380/420V-3ph - Z1EH0600B-1G	10Z15			X	X
ELECTRIC HEAT ACCESSORIES						
Unit Fuse Block (required) - See Electrical/Electric Heat Tables for Selection			X	X	X	X
ECONOMIZER						
Standard Economizer						
Standard Downflow Economizer with Single Temperature Control - With Barometric Relief Dampers and Air Hoods	Z1ECON30B-1	10Z29	OX	OX	OX	OX
Standard Horizontal Economizer with Single Temperature Control - With Barometric Relief Dampers and Air Hoods	Z1ECON16B-1	11G98	X	X	X	X
Standard Economizer Controls						
Single Enthalpy Control	C1SNSR64FF1	53W64	X	X	X	X
Differential Enthalpy Control (order 2)	C1SNSR64FF1	53W64	X	X	X	X
High Performance Economizer						
High Performance Downflow Economizer with Single Temperature Control - With Barometric Relief Dampers and Air Hoods	Z1ECON32B-3	20V25	OX	OX	OX	OX
High Horizontal Economizer with Single Temperature Control - With Barometric Relief Dampers and Air Hoods	Z1ECON33B-3	20V26	X	X	X	X
High Performance Economizer Controls						
Single Enthalpy Control	C1SNSR61FF1	11G21	X	X	X	X
Differential Enthalpy Control (order 2)	C1SNSR61FF1	11G21	X	X	X	X
Horizontal Low Profile Barometric Relief Dampers With Exhaust Hood						
Horizontal Low Profile Barometric Relief Dampers With Exhaust Hood	LAGEDH03/15	53K04	X	X	X	X
OUTDOOR AIR						
Outdoor Air Dampers						
Motorized Dampers with outdoor air hood	Z1DAMP20B-2	14G36	X	X	X	X
Manual Dampers with outdoor air hood	Z1DAMP10B-2	14G37	X	X	X	X
POWER EXHAUST						
Standard Static (Downflow)	380/420V-3ph - Z1PWRE10B-1G	10Z71	X	X	X	X
Standard Static (Horizontal)	380/420V-3ph - Z1PWRE15A-1G	28E01	X	X	X	X

¹ Nominal kW at 420V-3ph-50hz.

NOTE - Catalog and model numbers shown are for ordering field installed accessories.

OX - Configure To Order (Factory Installed) or Field Installed

O = Configure To Order (Factory Installed)

X = Field Installed

OPTIONS / ACCESSORIES

Item Description	Model Number	Catalog Number	Unit Model No			
			092	102	120	150
ROOF CURBS						
Hybrid Roof Curbs, Downflow						
203 mm height	Z1CURB40B-1	10Z25	X	X	X	X
356 mm height	Z1CURB41B-1	10Z26	X	X	X	X
457 mm height	Z1CURB42B-1	10Z27	X	X	X	X
610 mm height	Z1CURB43B-1	10Z28	X	X	X	X
CEILING DIFFUSERS						
Step-Down - Order one	RTD11-95S	13K61	X			
	RTD11-135S	13K62		X	X	
	RTD11-185S	13K63				X
Flush - Order one	FD11-95S	13K56	X			
	FD11-135S	13K57		X	X	
	FD11-185S	13K58				X

NOTE - Ceiling Diffuser Transitions are not furnished and must be field fabricated.

NOTE - Catalog and model numbers shown are for ordering field installed accessories.

OX - Configure To Order (Factory Installed) or Field Installed

O = Configure To Order (Factory Installed)

X = Field Installed

SPECIFICATIONS

General Data		Nominal kW (Tonnage)	26 (7.5)	30 (8.5)	35 (10)	44 (12.5)
Model Number			ZCB092S4B	ZCB102S4B	ZCB120S4B	ZCB150S4B
Efficiency Type			Standard	Standard	Standard	Standard
Blower Type			Constant Air Volume (CAV)	Constant Air Volume (CAV)	Constant Air Volume (CAV)	Constant Air Volume (CAV)
Cooling Performance	Gross Cooling Capacity - kW (Btuh)		23.2 (79 000)	25.9 (88 300)	30.3 (103 500)	36.0 (122 900)
	¹ Net Cooling Capacity - kW (Btuh)		22.5 (76 800)	25.1 (85 700)	29.3 (100 000)	34.5 (117 800)
	AHRI Rated Air Flow - L/s (cfm)		1320 (2800)	1535 (3250)	1465 (3100)	1746 (3700)
	Total Unit Power - kW		6.7	7.5	8.7	10.5
	¹ EER (Btuh/Watt) at 35°C (95°F)		11.5	11.4	11.5	11.2
	² EER (Btuh/Watt) at 46°C (115°F)		7.8	7.9	8.0	7.4
	¹ IEER (Btuh/Watt)		11.4	11.4	12.3	11.8
	Refrigerant Type		R-410A	R-410A	R-410A	R-410A
	Refrigerant Charge Furnished		2.0 kg (4 lbs. 7 oz.)	2.2 kg (4 lbs. 13 oz.)	2.8 kg (6 lbs 4 oz.)	5.6 kg (12 lbs 6 oz.)
	Circuit 2		1.4 kg (3 lbs. 1 oz.)	2.1 kg (4 lbs. 10 oz.)	2.5 kg (5 lbs 7 oz.)	6.1 kg (13 lbs 6 oz.)
Electric Heat Available - See page 10			5.7, 11.5, 17.2, 23, & 34.5 kW		5.7, 11.5, 17.2, 23, 34.5 & 45.9 kW	
Compressor Type (number)			Scroll (2)		Scroll (2)	
Outdoor Coils	Net face area (total) - m ² (sq. ft.)		1.94 (20.9)	1.94 (20.9)	2.6 (28.0)	2.58 (27.8)
	Tube diameter - mm (in.)		---	---	---	9.5 (3/8)
	Number of rows		1	1	1	1
	Fins per m (in.)		906 (23)	906 (23)	906 (23)	787 (20)
Outdoor Coil Fans	Motor - (No.) W (hp)		(2) 249 (1/3)	(2) 249 (1/3)	(2) 249 (1/3)	(2) 373 (1/2)
	Motor rev/min		896	896	896	896
	Total Motor watts		617	617	583	734
	Diameter - (No.) m (in.)		(2) 610 (24)	(2) 610 (24)	(2) 610 (24)	(2) 610 (24)
	Number of blades		3	3	3	3
	Total Air volume - L/s (cfm)		3460 (7333)	3460 (7333)	3540 (7500)	3775 (8000)
Indoor Coils	Net face area (total) - m ² (sq. ft.)		1.19 (12.8)	1.19 (12.8)	1.26 (13.54)	1.26 (13.54)
	Tube diameter - mm (in.)		9.5 (3/8)	9.5 (3/8)	9.5 (3/8)	9.5 (3/8)
	Number of rows		2	3	4	4
	Fins per m (in.)		551 (14)	551 (14)	551 (14)	551 (14)
	Drain connection - Number and size		(1) 1 in. NPT coupling			
Expansion device type			Refrigerant Metering Orifice (RFC)			
³ Indoor Blower and Drive Selection	Nominal motor output		1.5 kW, 2.2 kW, 3.7 kW (2 hp, 3 hp, 5 hp)			
	Maximum usable motor output		1.7 kW, 2.6 kW, 4.3 kW (2.3 hp, 3.45 hp, 5.75 hp)			
	Motor - Drive kit number		1.5 kW (2 hp) Kit 1 490-740 rev/min Kit 2 665-920 rev/min Kit 3 660-995 rev/min 2.2 kW (3 hp) Kit 7 610-810 rev/min Kit 8 780-1000 rev/min Kit 9 845-1085 rev/min 3.7 kW (5 hp) Kit 10 750-945 rev/min Kit 11 865-1095 rev/min Kit 12 940-1190 rev/min			
Blower wheel nominal diameter x width - mm (in.)			(1) 381 x 381 (15 X 15)			
Filters	Type of filter		Disposable			
	Number and size - mm (in.)		(4) 508 x 610 x 51 (20 x 24 x 2)			
Electrical characteristics			380/420V - 50 hertz - 3 phase with neutral			

NOTE - Net capacity includes evaporator blower motor heat deduction. Gross capacity does not include evaporator blower motor heat deduction.

¹ Tested at conditions included in AHRI Standard 340/360; 35°C (95°F) outdoor air temperature and 27°C (80°F) dry bulb /19°C (67°F) wet bulb entering evaporator air; minimum external duct static pressure while operating at rated voltage and air volumes.

² Rated at 46°C (115°F) outdoor air temperature and 27°C (80°F) db/19°C (67°F) wb entering evaporator air (T3 Conditions).

³ Using total air volume and system static pressure requirements determine from blower performance tables rev/min and motor output required. Maximum usable output of motors furnished are shown. If motors of comparable output are used, be sure to keep within the service factor limitations outlined on the motor nameplate.

RATINGS

NOTE – For Temperatures and Capacities not shown in tables, see bulletin – Cooling Unit Rating Table Correction Factor Data in Miscellaneous Engineering Data section.

26 KW STANDARD EFFICIENCY ZCB092S4B (1ST STAGE) - CONSTANT AIR VOLUME

Entering Wet Bulb Temperature	Total Air Volume	Outdoor Air Temperature Entering Outdoor Coil																			
		18.3°C					23.9°C					29.4°C					35°C				
		Total Cool Cap.	Comp. Motor Input	Sensible To Total Ratio (S/T)			Total Cool Cap.	Comp. Motor Input	Sensible To Total Ratio (S/T)			Total Cool Cap.	Comp. Motor Input	Sensible To Total Ratio (S/T)			Total Cool Cap.	Comp. Motor Input	Sensible To Total Ratio (S/T)		
				Dry Bulb					Dry Bulb					Dry Bulb					Dry Bulb		
L/s	kW	kW	24°C	27°C	29°C	kW	kW	24°C	27°C	29°C	kW	kW	24°C	27°C	29°C	kW	kW	24°C	27°C	29°C	
17.2°C	1135	16.6	2.27	0.68	0.81	0.95	15.9	2.53	0.69	0.83	0.97	15.1	2.83	0.70	0.84	0.99	14.2	3.19	0.71	0.87	1.00
	1415	17.5	2.29	0.72	0.87	1.00	16.7	2.55	0.73	0.89	1.00	15.9	2.85	0.74	0.91	1.00	14.9	3.21	0.76	0.94	1.00
	1700	18.2	2.30	0.76	0.93	1.00	17.4	2.56	0.77	0.95	1.00	16.5	2.86	0.78	0.98	1.00	15.5	3.22	0.80	1.00	1.00
19.4°C	1135	17.4	2.28	0.55	0.66	0.78	16.6	2.55	0.55	0.67	0.79	15.8	2.85	0.55	0.68	0.81	14.9	3.20	0.56	0.69	0.83
	1415	18.4	2.30	0.57	0.70	0.84	17.5	2.56	0.57	0.71	0.86	16.6	2.87	0.58	0.72	0.88	15.6	3.22	0.58	0.73	0.90
	1700	19.0	2.32	0.59	0.74	0.90	18.1	2.58	0.59	0.75	0.92	17.1	2.88	0.60	0.76	0.94	16.1	3.23	0.61	0.78	0.97
21.7°C	1135	18.2	2.30	0.42	0.53	0.64	17.4	2.56	0.42	0.54	0.65	16.5	2.86	0.42	0.54	0.66	15.6	3.22	0.42	0.55	0.67
	1415	19.2	2.32	0.43	0.56	0.68	18.3	2.58	0.43	0.56	0.69	17.3	2.88	0.42	0.57	0.70	16.3	3.23	0.42	0.57	0.72
	1700	19.9	2.34	0.45	0.58	0.71	19.0	2.59	0.44	0.59	0.73	17.9	2.89	0.45	0.59	0.74	16.8	3.25	0.45	0.60	0.76

26 KW STANDARD EFFICIENCY ZCB092S4B (2ND STAGE) - CONSTANT AIR VOLUME

Entering Wet Bulb Temperature	Total Air Volume	Outdoor Air Temperature Entering Outdoor Coil																			
		26.7°C					35°C					43.3°C					46°C				
		Total Cool Cap.	Comp. Motor Input	Sensible To Total Ratio (S/T)			Total Cool Cap.	Comp. Motor Input	Sensible To Total Ratio (S/T)			Total Cool Cap.	Comp. Motor Input	Sensible To Total Ratio (S/T)			Total Cool Cap.	Comp. Motor Input	Sensible To Total Ratio (S/T)		
				Dry Bulb					Dry Bulb					Dry Bulb					Dry Bulb		
L/s	kW	kW	24°C	27°C	29°C	kW	kW	24°C	27°C	29°C	kW	kW	24°C	27°C	29°C	kW	kW	24°C	27°C	29°C	
17.2°C	1135	23.0	4.47	0.71	0.86	0.99	20.8	5.36	0.73	0.90	1.00	18.4	6.46	0.76	0.95	1.00	17.1	6.66	0.79	1.00	1.00
	1415	24.2	4.50	0.76	0.94	1.00	21.9	5.39	0.79	0.98	1.00	19.5	6.50	0.83	1.00	1.00	18.6	6.70	0.87	1.00	1.00
	1700	25.1	4.51	0.81	0.99	1.00	22.8	5.41	0.85	1.00	1.00	20.5	6.53	0.91	1.00	1.00	19.8	6.73	0.95	1.00	1.00
19.4°C	1135	24.3	4.50	0.56	0.69	0.82	22.0	5.39	0.57	0.71	0.86	19.6	6.50	0.57	0.74	0.91	18.3	6.69	0.60	0.80	0.94
	1415	25.6	4.52	0.59	0.74	0.90	23.2	5.42	0.60	0.76	0.95	20.5	6.53	0.62	0.81	0.99	19.4	6.72	0.65	0.89	1.00
	1700	26.5	4.54	0.62	0.79	0.97	24.0	5.44	0.63	0.82	1.00	21.1	6.55	0.65	0.88	1.00	20.2	6.74	0.70	0.96	1.00
21.7°C	1135	25.5	4.52	0.42	0.55	0.67	23.2	5.42	0.41	0.56	0.69	20.7	6.54	0.40	0.57	0.71	20.1	6.73	0.35	0.54	0.66
	1415	26.8	4.54	0.43	0.58	0.72	24.4	5.45	0.43	0.59	0.74	21.7	6.57	0.43	0.61	0.78	21.2	6.76	0.37	0.59	0.73
	1700	27.8	4.56	0.44	0.61	0.76	25.3	5.47	0.44	0.63	0.80	22.4	6.60	0.45	0.65	0.86	22.0	6.78	0.39	0.64	0.79

Entering Wet Bulb Temperature	Total Air Volume	Outdoor Air Temperature Entering Outdoor Coil														
		48°C					50°C					51.7°C				
		Total Cool Cap.	Comp. Motor Input	Sensible To Total Ratio (S/T)			Total Cool Cap.	Comp. Motor Input	Sensible To Total Ratio (S/T)			Total Cool Cap.	Comp. Motor Input	Sensible To Total Ratio (S/T)		
				Dry Bulb					Dry Bulb					Dry Bulb		
L/s	kW	kW	24°C	27°C	29°C	kW	kW	24°C	27°C	29°C	kW	kW	24°C	27°C	29°C	
17.2°C	1135	16.4	6.97	0.80	1.00	1.00	15.6	7.31	0.81	1.00	1.00	15.9	7.84	0.81	1.00	1.00
	1415	17.9	7.01	0.88	1.00	1.00	17.1	7.35	0.90	1.00	1.00	17.0	7.88	0.90	1.00	1.00
	1700	19.0	7.04	0.96	1.00	1.00	18.2	7.38	0.98	1.00	1.00	17.8	7.92	0.97	1.00	1.00
19.4°C	1135	17.5	7.00	0.60	0.81	0.95	16.6	7.33	0.60	0.83	0.97	16.8	7.88	0.59	0.78	0.98
	1415	18.6	7.03	0.66	0.90	1.00	17.6	7.37	0.66	0.92	1.00	17.5	7.91	0.64	0.88	1.00
	1700	19.3	7.05	0.71	0.98	1.00	18.4	7.39	0.72	0.99	1.00	18.0	7.94	0.69	0.96	1.00
21.7°C	1135	19.2	7.05	0.33	0.54	0.67	18.3	7.38	0.32	0.54	0.68	17.8	7.92	0.40	0.59	0.76
	1415	20.3	7.08	0.37	0.59	0.74	19.4	7.41	0.36	0.60	0.75	18.6	7.96	0.43	0.64	0.85
	1700	21.1	7.10	0.38	0.64	0.81	20.1	7.44	0.37	0.65	0.82	19.2	7.99	0.46	0.69	0.94

RATINGS

NOTE – For Temperatures and Capacities not shown in tables, see bulletin – Cooling Unit Rating Table Correction Factor Data in Miscellaneous Engineering Data section.

30 KW STANDARD EFFICIENCY ZCB102S4B (1ST STAGE) - CONSTANT AIR VOLUME

Entering Wet Bulb Temperature	Total Air Volume	Outdoor Air Temperature Entering Outdoor Coil																							
		18.3°C						23.9°C						29.4°C						35°C					
		Total Cool Cap.	Comp. Motor Input	Sensible To Total Ratio (S/T)			Total Cool Cap.	Comp. Motor Input	Sensible To Total Ratio (S/T)			Total Cool Cap.	Comp. Motor Input	Sensible To Total Ratio (S/T)			Total Cool Cap.	Comp. Motor Input	Sensible To Total Ratio (S/T)						
				Dry Bulb					Dry Bulb					Dry Bulb					Dry Bulb						
L/s	kW	kW	24°C	27°C	29°C	kW	kW	24°C	27°C	29°C	kW	kW	24°C	27°C	29°C	kW	kW	24°C	27°C	29°C					
17.2°C	1285	17.3	2.23	0.70	0.84	0.96	16.6	2.56	0.71	0.86	0.97	15.8	2.90	0.72	0.87	0.97	15.0	3.29	0.73	0.89	0.97				
	1605	18.1	2.25	0.73	0.90	0.96	17.3	2.57	0.74	0.91	0.96	16.5	2.92	0.76	0.93	0.96	15.7	3.31	0.76	0.95	0.96				
	1925	18.6	2.25	0.76	0.94	0.96	17.9	2.58	0.77	0.95	0.96	17.1	2.93	0.79	0.95	0.96	16.2	3.32	0.80	0.94	0.95				
19.4°C	1285	18.1	2.25	0.54	0.67	0.80	17.3	2.57	0.54	0.68	0.82	16.6	2.92	0.54	0.69	0.83	15.8	3.31	0.55	0.71	0.85				
	1605	19.0	2.26	0.55	0.71	0.86	18.1	2.58	0.56	0.72	0.88	17.3	2.93	0.56	0.73	0.89	16.3	3.32	0.57	0.74	0.91				
	1925	19.5	2.26	0.56	0.74	0.91	18.6	2.59	0.57	0.75	0.92	17.7	2.94	0.57	0.76	0.94	16.7	3.33	0.58	0.78	0.94				
21.7°C	1285	18.8	2.25	0.38	0.52	0.64	18.1	2.58	0.39	0.53	0.65	17.2	2.93	0.38	0.53	0.66	16.4	3.32	0.39	0.53	0.68				
	1605	19.6	2.26	0.39	0.53	0.68	18.8	2.59	0.39	0.54	0.69	17.8	2.94	0.38	0.55	0.7	16.9	3.33	0.39	0.55	0.72				
	1925	20.1	2.27	0.38	0.55	0.71	19.2	2.59	0.38	0.55	0.72	18.2	2.95	0.38	0.56	0.74	17.2	3.33	0.37	0.57	0.75				

30 KW STANDARD EFFICIENCY ZCB102S4B (2ND STAGE) - CONSTANT AIR VOLUME

Entering Wet Bulb Temperature	Total Air Volume	Outdoor Air Temperature Entering Outdoor Coil																							
		26.7°C						35°C						43.3°C						46°C					
		Total Cool Cap.	Comp. Motor Input	Sensible To Total Ratio (S/T)			Total Cool Cap.	Comp. Motor Input	Sensible To Total Ratio (S/T)			Total Cool Cap.	Comp. Motor Input	Sensible To Total Ratio (S/T)			Total Cool Cap.	Comp. Motor Input	Sensible To Total Ratio (S/T)						
				Dry Bulb					Dry Bulb					Dry Bulb					Dry Bulb						
L/s	kW	kW	24°C	27°C	29°C	kW	kW	24°C	27°C	29°C	kW	kW	24°C	27°C	29°C	kW	kW	24°C	27°C	29°C					
17.2°C	1285	25.4	5.08	0.78	0.91	0.98	23.4	6.11	0.80	0.94	0.99	21.3	7.33	0.84	0.97	0.98	18.9	8.82	0.88	0.98	0.98				
	1605	26.6	5.11	0.83	0.96	0.98	24.6	6.15	0.86	0.97	0.98	22.5	7.38	0.89	0.98	0.98	20.0	8.87	0.94	0.98	0.98				
	1925	27.7	5.14	0.87	0.98	0.98	25.7	6.18	0.90	0.98	0.98	23.5	7.42	0.94	0.97	0.98	20.9	8.90	0.96	0.97	0.98				
19.4°C	1285	26.9	5.12	0.60	0.75	0.88	24.8	6.16	0.62	0.78	0.91	22.5	7.38	0.64	0.81	0.94	19.8	8.86	0.67	0.86	0.97				
	1605	28.2	5.15	0.63	0.80	0.94	25.9	6.19	0.65	0.84	0.96	23.4	7.41	0.67	0.87	0.97	20.4	8.89	0.71	0.92	0.97				
	1925	29.0	5.17	0.66	0.85	0.97	26.6	6.21	0.68	0.88	0.97	23.9	7.43	0.71	0.92	0.97	21.0	8.91	0.76	0.96	0.97				
21.7°C	1285	28.4	5.16	0.44	0.58	0.72	26.2	6.20	0.44	0.60	0.75	23.8	7.43	0.45	0.62	0.78	21.0	8.91	0.46	0.65	0.84				
	1605	29.7	5.18	0.45	0.61	0.77	27.4	6.23	0.45	0.63	0.81	24.7	7.46	0.46	0.66	0.85	21.7	8.94	0.47	0.70	0.90				
	1925	30.7	5.20	0.45	0.65	0.83	28.2	6.26	0.46	0.67	0.86	25.4	7.48	0.47	0.70	0.90	22.2	8.95	0.49	0.74	0.95				

Entering Wet Bulb Temperature	Total Air Volume	Outdoor Air Temperature Entering Outdoor Coil																	
		48°C						50°C						51.7°C					
		Total Cool Cap.	Comp. Motor Input	Sensible To Total Ratio (S/T)			Total Cool Cap.	Comp. Motor Input	Sensible To Total Ratio (S/T)			Total Cool Cap.	Comp. Motor Input	Sensible To Total Ratio (S/T)					
				Dry Bulb					Dry Bulb					Dry Bulb					
L/s	kW	kW	24°C	27°C	29°C	kW	kW	24°C	27°C	29°C	kW	kW	24°C	27°C	29°C				
17.2°C	1285	20.2	7.74	0.79	0.97	0.97	19.3	8.09	0.80	0.97	0.97	18.5	8.46	0.82	0.97	0.97			
	1605	22.0	7.79	0.88	0.96	0.97	21.2	8.14	0.90	0.96	0.97	20.2	8.50	0.91	0.96	0.97			
	1925	23.5	7.83	0.94	0.96	0.97	22.5	8.18	0.94	0.96	0.96	21.6	8.54	0.94	0.96	0.96			
19.4°C	1285	21.4	7.77	0.58	0.81	0.94	20.4	8.12	0.58	0.82	0.95	19.3	8.48	0.59	0.83	0.96			
	1605	22.5	7.81	0.64	0.90	0.96	21.5	8.15	0.65	0.91	0.96	20.4	8.51	0.65	0.93	0.96			
	1925	23.5	7.83	0.69	0.94	0.95	22.6	8.18	0.70	0.95	0.95	21.5	8.54	0.71	0.94	0.95			
21.7°C	1285	23.9	7.84	0.31	0.52	0.65	22.9	8.19	0.30	0.52	0.66	21.8	8.55	0.29	0.52	0.66			
	1605	25.1	7.87	0.33	0.57	0.72	24.0	8.22	0.32	0.57	0.73	22.9	8.58	0.31	0.58	0.74			
	1925	26.0	7.89	0.34	0.61	0.79	24.9	8.23	0.34	0.62	0.80	23.7	8.60	0.33	0.63	0.82			

RATINGS

NOTE – For Temperatures and Capacities not shown in tables, see bulletin – Cooling Unit Rating Table Correction Factor Data in Miscellaneous Engineering Data section.

35 KW STANDARD EFFICIENCY ZCB120S4B (1ST STAGE) - CONSTANT AIR VOLUME

Entering Wet Bulb Temperature	Total Air Volume	Outdoor Air Temperature Entering Outdoor Coil																			
		18.3°C					23.9°C					29.4°C					35°C				
		Total Cool Cap.	Comp. Motor Input	Sensible To Total Ratio (S/T)			Total Cool Cap.	Comp. Motor Input	Sensible To Total Ratio (S/T)			Total Cool Cap.	Comp. Motor Input	Sensible To Total Ratio (S/T)			Total Cool Cap.	Comp. Motor Input	Sensible To Total Ratio (S/T)		
				Dry Bulb					Dry Bulb					Dry Bulb					Dry Bulb		
L/s	kW	kW	24°C	27°C	29°C	kW	kW	24°C	27°C	29°C	kW	kW	24°C	27°C	29°C	kW	kW	24°C	27°C	29°C	
17.2°C	1510	17.7	2.37	0.76	0.92	1.00	16.5	2.71	0.76	0.93	1.00	15.4	3.03	0.77	0.95	1.00	14.1	3.46	0.79	0.99	1.00
	1700	18.3	2.37	0.78	0.96	1.00	17.1	2.72	0.80	0.98	1.00	15.9	3.04	0.81	1.00	1.00	14.7	3.48	0.83	1.00	1.00
	1890	18.8	2.38	0.82	0.99	1.00	17.6	2.73	0.83	1.00	1.00	16.5	3.05	0.85	1.00	1.00	15.3	3.49	0.87	1.00	1.00
19.4°C	1510	18.9	2.38	0.61	0.76	0.85	17.7	2.73	0.61	0.77	0.88	16.5	3.06	0.61	0.78	0.89	15.1	3.49	0.61	0.80	0.92
	1700	19.5	2.39	0.63	0.79	0.90	18.2	2.74	0.64	0.81	0.91	17.1	3.06	0.64	0.82	0.94	15.6	3.49	0.64	0.84	0.97
	1890	20.0	2.39	0.66	0.82	0.94	18.7	2.74	0.66	0.84	0.96	17.5	3.07	0.66	0.86	0.98	15.9	3.50	0.66	0.88	1.00
21.7°C	1510	20.7	2.39	0.42	0.56	0.64	19.4	2.75	0.41	0.56	0.65	18.3	3.08	0.40	0.55	0.65	16.8	3.51	0.38	0.55	0.67
	1700	21.4	2.40	0.43	0.57	0.67	20.0	2.75	0.41	0.57	0.67	18.8	3.09	0.40	0.58	0.69	17.3	3.52	0.39	0.58	0.70
	1890	21.9	2.41	0.44	0.59	0.69	20.5	2.76	0.42	0.60	0.71	19.3	3.09	0.41	0.60	0.72	17.7	3.53	0.40	0.60	0.73

35 KW STANDARD EFFICIENCY ZCB120S4B (2ND STAGE) - CONSTANT AIR VOLUME

Entering Wet Bulb Temperature	Total Air Volume	Outdoor Air Temperature Entering Outdoor Coil																			
		26.7°C					35°C					43.3°C					46°C				
		Total Cool Cap.	Comp. Motor Input	Sensible To Total Ratio (S/T)			Total Cool Cap.	Comp. Motor Input	Sensible To Total Ratio (S/T)			Total Cool Cap.	Comp. Motor Input	Sensible To Total Ratio (S/T)			Total Cool Cap.	Comp. Motor Input	Sensible To Total Ratio (S/T)		
				Dry Bulb					Dry Bulb					Dry Bulb					Dry Bulb		
L/s	kW	kW	24°C	27°C	29°C	kW	kW	24°C	27°C	29°C	kW	kW	24°C	27°C	29°C	kW	kW	24°C	27°C	29°C	
17.2°C	1510	31.8	5.69	0.77	0.94	1.00	28.1	6.85	0.79	0.98	1.00	24.4	8.20	0.82	1.00	1.00	23.2	8.68	0.82	1.00	1.00
	1700	32.9	5.72	0.81	0.99	1.00	29.3	6.87	0.83	1.00	1.00	25.7	8.23	0.86	1.00	1.00	24.5	8.72	0.88	1.00	1.00
	1890	34.1	5.73	0.84	1.00	1.00	30.6	6.90	0.87	1.00	1.00	26.8	8.26	0.91	1.00	1.00	25.7	8.74	0.93	1.00	1.00
19.4°C	1510	34.1	5.74	0.61	0.77	0.88	30.2	6.90	0.61	0.80	0.92	26.1	8.24	0.61	0.83	0.97	24.7	8.72	0.61	0.84	0.98
	1700	35.1	5.75	0.64	0.81	0.93	31.2	6.91	0.64	0.84	0.97	26.9	8.26	0.64	0.87	1.00	25.5	8.74	0.64	0.89	1.00
	1890	36.1	5.76	0.66	0.85	0.97	31.9	6.92	0.66	0.88	1.00	27.5	8.27	0.67	0.93	1.00	26.1	8.75	0.68	0.94	1.00
21.7°C	1510	37.7	5.78	0.40	0.55	0.65	33.6	6.95	0.38	0.55	0.66	29.3	8.30	0.36	0.55	0.68	27.9	8.79	0.34	0.55	0.68
	1700	38.7	5.79	0.41	0.58	0.68	34.6	6.96	0.39	0.58	0.70	30.2	8.32	0.37	0.58	0.72	28.6	8.79	0.36	0.58	0.72
	1890	39.7	5.80	0.42	0.60	0.71	35.5	6.97	0.40	0.60	0.73	30.9	8.33	0.38	0.61	0.75	29.4	8.81	0.37	0.61	0.76

Entering Wet Bulb Temperature	Total Air Volume	Outdoor Air Temperature Entering Outdoor Coil														
		48°C					50°C					51.7°C				
		Total Cool Cap.	Comp. Motor Input	Sensible To Total Ratio (S/T)			Total Cool Cap.	Comp. Motor Input	Sensible To Total Ratio (S/T)			Total Cool Cap.	Comp. Motor Input	Sensible To Total Ratio (S/T)		
				Dry Bulb					Dry Bulb					Dry Bulb		
L/s	kW	kW	24°C	27°C	29°C	kW	kW	24°C	27°C	29°C	kW	kW	24°C	27°C	29°C	
17.2°C	1510	22.3	9.05	0.83	1.00	1.00	21.3	9.45	0.85	1.00	1.00	20.6	9.81	0.86	1.00	1.00
	1700	23.6	9.10	0.89	1.00	1.00	22.6	9.49	0.91	1.00	1.00	21.8	9.84	0.93	1.00	1.00
	1890	24.6	9.11	0.95	1.00	1.00	23.6	9.51	0.97	1.00	1.00	22.7	9.86	0.98	1.00	1.00
19.4°C	1510	23.6	9.09	0.61	0.85	1.00	22.5	9.49	0.61	0.86	1.00	21.5	9.83	0.62	0.87	1.00
	1700	24.4	9.11	0.65	0.91	1.00	23.3	9.50	0.65	0.92	1.00	22.3	9.85	0.65	0.94	1.00
	1890	25.1	9.13	0.68	0.96	1.00	23.9	9.52	0.69	0.98	1.00	22.9	9.87	0.70	0.99	1.00
21.7°C	1510	26.8	9.16	0.33	0.55	0.69	25.6	9.56	0.32	0.55	0.69	24.6	9.90	0.31	0.55	0.70
	1700	27.5	9.17	0.35	0.58	0.73	26.3	9.57	0.34	0.58	0.74	25.4	9.92	0.34	0.59	0.75
	1890	28.2	9.18	0.37	0.61	0.78	27.0	9.58	0.36	0.61	0.78	26.0	9.92	0.35	0.62	0.80

RATINGS

NOTE – For Temperatures and Capacities not shown in tables, see bulletin – Cooling Unit Rating Table Correction Factor Data in Miscellaneous Engineering Data section.

44 KW STANDARD EFFICIENCY ZCB150S4B (1ST STAGE) - CONSTANT AIR VOLUME

Entering Wet Bulb Temperature	Total Air Volume	Outdoor Air Temperature Entering Outdoor Coil																			
		18.3°C					23.9°C					29.4°C					35°C				
		Total Cool Cap.	Comp. Motor Input	Sensible To Total Ratio (S/T)			Total Cool Cap.	Comp. Motor Input	Sensible To Total Ratio (S/T)			Total Cool Cap.	Comp. Motor Input	Sensible To Total Ratio (S/T)			Total Cool Cap.	Comp. Motor Input	Sensible To Total Ratio (S/T)		
				Dry Bulb					Dry Bulb					Dry Bulb					Dry Bulb		
L/s	kW	kW	24°C	27°C	29°C	kW	kW	24°C	27°C	29°C	kW	kW	24°C	27°C	29°C	kW	kW	24°C	27°C	29°C	
17.2°C	2075	22.9	3.12	0.72	0.89	0.99	21.6	3.48	0.72	0.90	1.00	20.3	3.81	0.73	0.92	1.00	18.8	4.25	0.74	0.95	1.00
	2265	23.4	3.12	0.74	0.92	1.00	22.0	3.48	0.75	0.94	1.00	20.8	3.80	0.76	0.96	1.00	19.3	4.24	0.77	0.98	1.00
	2455	23.9	3.11	0.76	0.95	1.00	22.5	3.47	0.77	0.97	1.00	21.3	3.80	0.78	0.99	1.00	19.8	4.24	0.80	1.00	1.00
19.4°C	2075	24.3	3.11	0.57	0.72	0.82	22.9	3.48	0.56	0.73	0.84	21.7	3.80	0.57	0.74	0.85	20.1	4.23	0.57	0.75	0.87
	2265	24.9	3.11	0.58	0.74	0.85	23.4	3.47	0.58	0.76	0.87	22.2	3.80	0.58	0.76	0.89	20.6	4.23	0.59	0.78	0.91
	2455	25.3	3.10	0.60	0.77	0.88	23.9	3.47	0.60	0.78	0.90	22.6	3.79	0.60	0.79	0.92	21.0	4.24	0.59	0.81	0.95
21.7°C	2075	26.5	3.11	0.38	0.52	0.60	25.1	3.48	0.37	0.52	0.61	23.8	3.79	0.36	0.51	0.60	22.2	4.22	0.35	0.51	0.62
	2265	27.0	3.09	0.39	0.53	0.62	25.6	3.46	0.38	0.52	0.63	24.3	3.79	0.37	0.53	0.63	22.7	4.21	0.36	0.52	0.64
	2455	27.5	3.09	0.39	0.54	0.64	25.9	3.46	0.38	0.54	0.65	24.7	3.78	0.37	0.54	0.65	23.0	4.22	0.37	0.54	0.66

44 KW STANDARD EFFICIENCY ZCB150S4B (2ND STAGE) - CONSTANT AIR VOLUME

Entering Wet Bulb Temperature	Total Air Volume	Outdoor Air Temperature Entering Outdoor Coil																			
		26.7°C					35°C					43.3°C					46°C				
		Total Cool Cap.	Comp. Motor Input	Sensible To Total Ratio (S/T)			Total Cool Cap.	Comp. Motor Input	Sensible To Total Ratio (S/T)			Total Cool Cap.	Comp. Motor Input	Sensible To Total Ratio (S/T)			Total Cool Cap.	Comp. Motor Input	Sensible To Total Ratio (S/T)		
				Dry Bulb					Dry Bulb					Dry Bulb					Dry Bulb		
L/s	kW	kW	24°C	27°C	29°C	kW	kW	24°C	27°C	29°C	kW	kW	24°C	27°C	29°C	kW	kW	24°C	27°C	29°C	
17.2°C	2075	44.9	8.91	0.74	0.93	1.00	39.8	10.46	0.76	0.97	1.00	34.7	12.33	0.80	1.00	1.00	29.5	14.62	0.87	1.00	1.00
	2265	45.8	8.95	0.76	0.96	1.00	40.8	10.50	0.79	1.00	1.00	35.8	12.40	0.84	1.00	1.00	30.6	14.69	0.91	1.00	1.00
	2455	46.7	8.99	0.79	0.99	1.00	41.9	10.55	0.83	1.00	1.00	36.8	12.44	0.88	1.00	1.00	31.4	14.74	0.96	1.00	1.00
19.4°C	2075	47.6	9.03	0.58	0.74	0.86	42.4	10.58	0.58	0.77	0.90	36.7	12.45	0.59	0.82	0.96	30.7	14.69	0.62	0.89	1.00
	2265	48.6	9.07	0.59	0.77	0.90	43.2	10.62	0.60	0.81	0.94	37.4	12.48	0.61	0.86	1.00	31.2	14.73	0.64	0.93	1.00
	2455	49.4	9.11	0.61	0.80	0.93	44.0	10.66	0.62	0.84	0.98	38.1	12.51	0.64	0.90	1.00	31.8	14.75	0.67	0.98	1.00
21.7°C	2075	51.9	9.22	0.37	0.52	0.62	46.5	10.79	0.36	0.52	0.63	40.5	12.65	0.34	0.53	0.66	34.1	14.89	0.32	0.55	0.70
	2265	52.8	9.26	0.37	0.53	0.64	47.2	10.83	0.36	0.54	0.66	41.2	12.68	0.35	0.55	0.69	34.6	14.91	0.33	0.57	0.74
	2455	53.6	9.31	0.38	0.55	0.66	47.9	10.86	0.37	0.56	0.69	41.7	12.71	0.36	0.58	0.73	35.1	14.93	0.34	0.60	0.78

Entering Wet Bulb Temperature	Total Air Volume	Outdoor Air Temperature Entering Outdoor Coil																	
		48°C					50°C					51.7°C							
		Total Cool Cap.	Comp. Motor Input	Sensible To Total Ratio (S/T)			Total Cool Cap.	Comp. Motor Input	Sensible To Total Ratio (S/T)			Total Cool Cap.	Comp. Motor Input	Sensible To Total Ratio (S/T)					
				Dry Bulb					Dry Bulb					Dry Bulb					
L/s	kW	kW	24°C	27°C	29°C	kW	kW	24°C	27°C	29°C	kW	kW	24°C	27°C	29°C				
17.2°C	2075	33.1	13.02	0.82	1.00	1.00	31.9	13.56	0.83	1.00	1.00	30.6	14.13	0.85	1.00	1.00			
	2265	34.2	13.08	0.86	1.00	1.00	32.9	13.62	0.88	1.00	1.00	31.6	14.18	0.89	1.00	1.00			
	2455	35.2	13.13	0.90	1.00	1.00	33.9	13.67	0.92	1.00	1.00	32.5	14.24	0.94	1.00	1.00			
19.4°C	2075	34.8	13.11	0.60	0.84	0.99	33.4	13.64	0.60	0.85	1.00	31.9	14.20	0.61	0.87	1.00			
	2265	35.5	13.15	0.62	0.88	1.00	34.1	13.68	0.63	0.90	1.00	32.6	14.25	0.64	0.92	1.00			
	2455	36.1	13.19	0.65	0.92	1.00	34.6	13.72	0.66	0.94	1.00	33.1	14.27	0.66	0.96	1.00			
21.7°C	2075	38.5	13.32	0.33	0.54	0.67	36.9	13.84	0.33	0.54	0.68	35.4	14.40	0.32	0.54	0.69			
	2265	39.1	13.35	0.34	0.56	0.71	37.6	13.88	0.34	0.56	0.72	36.0	14.43	0.33	0.57	0.73			
	2455	39.6	13.38	0.35	0.58	0.74	38.1	13.91	0.35	0.59	0.75	36.5	14.46	0.34	0.60	0.77			

BLOWER DATA

092 STANDARD EFFICIENCY BELT DRIVE BLOWER – BASE UNIT

BLOWER TABLE INCLUDES RESISTANCE FOR BASE UNIT ONLY (NO HEAT SECTION) WITH DRY INDOOR COIL AND AIR FILTERS IN PLACE. FOR ALL UNITS ADD:

- 1 – Wet indoor coil air resistance of selected unit.
- 2 – Any factory installed options air resistance (heat section, economizer, etc.)
- 3 – Any field installed accessories air resistance (duct resistance, diffuser, etc.)

Then determine from blower table blower motor output required.

See page 20 for blower motors and drives.

See page 20 for wet coil and option/accessory air resistance data.

MINIMUM AIR VOLUME REQUIRED FOR USE WITH OPTIONAL ELECTRIC HEAT - Maximum Static Pressure - 500 Pa (2.0 in. w.g.)

5.7 kW, 11.5 kW, 17.2 kW - 975 L/s (2065 cfm)

23 kW - 1060 L/s (2250 cfm)

34.5 kW - 1240 L/s (2625 cfm)

Total Air Volume		TOTAL STATIC PRESSURE - Pa (Inches Water Gauge)																				
		50 (0.20)			100 (0.40)			150 (0.60)			200 (0.80)			250 (1.00)			300 (1.20)			350 (1.40)		
L/s	cfm	rev/min	kW	BHP	rev/min	kW	BHP	rev/min	kW	BHP	rev/min	kW	BHP	rev/min	kW	BHP	rev/min	kW	BHP	rev/min	kW	BHP
825	1750	494	0.08	0.11	562	0.25	0.34	632	0.42	0.56	702	0.55	0.74	771	0.63	0.85	838	0.72	0.96	902	0.80	1.07
945	2000	514	0.19	0.26	581	0.37	0.49	650	0.52	0.7	719	0.65	0.87	786	0.73	0.98	852	0.81	1.09	915	0.90	1.20
1060	2250	533	0.31	0.41	599	0.46	0.62	667	0.61	0.82	735	0.74	0.99	802	0.82	1.10	866	0.90	1.21	928	0.99	1.33
1180	2500	553	0.41	0.55	619	0.57	0.76	685	0.71	0.95	753	0.82	1.10	818	0.91	1.22	881	1.00	1.34	942	1.10	1.47
1300	2750	573	0.52	0.70	638	0.67	0.90	705	0.81	1.08	771	0.91	1.22	835	1.01	1.35	897	1.11	1.49	957	1.22	1.63
1415	3000	594	0.63	0.85	659	0.78	1.05	725	0.91	1.22	791	1.01	1.36	853	1.12	1.5	915	1.23	1.65	973	1.35	1.81
1535	3250	617	0.75	1.01	682	0.90	1.20	747	1.02	1.37	812	1.13	1.52	873	1.25	1.67	934	1.37	1.83	990	1.50	2.01
1650	3500	640	0.87	1.17	706	1.01	1.36	771	1.14	1.53	834	1.27	1.70	895	1.39	1.86	954	1.51	2.03	1008	1.66	2.23
1770	3750	665	1.00	1.34	731	1.15	1.54	796	1.28	1.72	857	1.41	1.89	917	1.54	2.07	975	1.69	2.26	1027	1.85	2.48
1890	4000	692	1.15	1.54	758	1.31	1.75	822	1.44	1.93	882	1.57	2.11	940	1.72	2.3	996	1.87	2.51	1047	2.06	2.76
2005	4250	722	1.31	1.76	787	1.47	1.97	849	1.60	2.15	908	1.75	2.35	965	1.91	2.56	1018	2.08	2.79	1067	2.28	3.06

Total Air Volume		TOTAL STATIC PRESSURE - Pa (Inches Water Gauge)																				
		400 (1.60)			450 (1.80)			500 (2.00)			550 (2.20)			600 (2.40)			650 (2.60)					
L/s	cfm	rev/min	kW	BHP	rev/min	kW	BHP	rev/min	kW	BHP	rev/min	kW	BHP	rev/min	kW	BHP	rev/min	kW	BHP	rev/min	kW	BHP
825	1750	961	0.89	1.19	---	---	---	---	---	---	---	---	---	---	---	---	---	---	---	---	---	---
945	2000	972	0.98	1.32	1026	1.10	1.47	1076	1.23	1.65	---	---	---	---	---	---	---	---	---	---	---	---
1060	2250	984	1.09	1.46	1037	1.22	1.63	1085	1.35	1.81	1132	1.50	2.01	1178	1.65	2.21	1226	1.81	2.43	---	---	---
1180	2500	997	1.21	1.62	1048	1.34	1.80	1096	1.48	1.99	1142	1.64	2.2	1188	1.80	2.41	1237	1.97	2.64	---	---	---
1300	2750	1011	1.34	1.80	1061	1.48	1.99	1108	1.63	2.19	1154	1.80	2.41	1200	1.96	2.63	1249	2.14	2.87	---	---	---
1415	3000	1026	1.48	1.99	1075	1.64	2.20	1121	1.81	2.42	1167	1.97	2.64	1213	2.14	2.87	1262	2.33	3.12	---	---	---
1535	3250	1042	1.65	2.21	1089	1.81	2.43	1135	1.98	2.66	1181	2.16	2.9	1228	2.33	3.13	1277	2.52	3.38	---	---	---
1650	3500	1058	1.84	2.46	1105	2.01	2.69	1150	2.19	2.93	1196	2.36	3.17	1243	2.54	3.41	1293	2.72	3.65	---	---	---
1770	3750	1076	2.03	2.72	1121	2.22	2.97	1166	2.40	3.22	1212	2.58	3.46	1261	2.77	3.71	1311	2.95	3.96	---	---	---
1890	4000	1094	2.25	3.02	1139	2.44	3.27	1184	2.63	3.52	1230	2.81	3.77	1280	3.01	4.03	1330	3.20	4.29	---	---	---
2005	4250	1113	2.48	3.33	1157	2.68	3.59	1202	2.87	3.85	1250	3.07	4.11	1300	3.27	4.38	1352	3.47	4.65	---	---	---

BLOWER DATA

102 STANDARD EFFICIENCY BELT DRIVE BLOWER – BASE UNIT

BLOWER TABLE INCLUDES RESISTANCE FOR BASE UNIT ONLY (NO HEAT SECTION) WITH DRY INDOOR COIL AND AIR FILTERS IN PLACE. FOR ALL UNITS ADD:

- 1 – Wet indoor coil air resistance of selected unit.
- 2 – Any factory installed options air resistance (heat section, economizer, etc.)
- 3 – Any field installed accessories air resistance (duct resistance, diffuser, etc.)

Then determine from blower table blower motor output required.

See page 21 for blower motors and drives.

See page 21 for wet coil and option/accessory air resistance data.

MINIMUM AIR VOLUME REQUIRED FOR USE WITH OPTIONAL ELECTRIC HEAT - Maximum Static Pressure - 500 Pa (2.0 in. w.g.)

5.7 kW, 11.5 kW, 17.2 kW - 975 L/s (2065 cfm)

23 kW - 1060 L/s (2250 cfm)

34.5 kW - 1240 L/s (2625 cfm)

Total Air Volume		TOTAL STATIC PRESSURE - Pa (Inches Water Gauge)																				
		50 (0.20)			100 (0.40)			150 (0.60)			200 (0.80)			250 (1.00)			300 (1.20)			350 (1.40)		
L/s	cfm	rev/min	kW	BHP	rev/min	kW	BHP	rev/min	kW	BHP	rev/min	kW	BHP	rev/min	kW	BHP	rev/min	kW	BHP	rev/min	kW	BHP
825	1750	494	0.08	0.11	562	0.25	0.34	632	0.42	0.56	702	0.55	0.74	771	0.63	0.85	838	0.72	0.96	902	0.80	1.07
945	2000	514	0.19	0.26	581	0.37	0.49	650	0.52	0.70	719	0.65	0.87	786	0.73	0.98	852	0.81	1.09	915	0.90	1.20
1060	2250	533	0.31	0.41	599	0.46	0.62	667	0.61	0.82	735	0.74	0.99	802	0.82	1.10	866	0.90	1.21	928	0.99	1.33
1180	2500	553	0.41	0.55	619	0.57	0.76	685	0.71	0.95	753	0.82	1.10	818	0.91	1.22	881	1.00	1.34	942	1.10	1.47
1300	2750	573	0.52	0.70	638	0.67	0.90	705	0.81	1.08	771	0.91	1.22	835	1.01	1.35	897	1.11	1.49	957	1.22	1.63
1415	3000	594	0.63	0.85	659	0.78	1.05	725	0.91	1.22	791	1.01	1.36	853	1.12	1.50	915	1.23	1.65	973	1.35	1.81
1535	3250	617	0.75	1.01	682	0.90	1.20	747	1.02	1.37	812	1.13	1.52	873	1.25	1.67	934	1.37	1.83	990	1.50	2.01
1650	3500	640	0.87	1.17	706	1.01	1.36	771	1.14	1.53	834	1.27	1.70	895	1.39	1.86	954	1.51	2.03	1008	1.66	2.23
1770	3750	665	1.00	1.34	731	1.15	1.54	796	1.28	1.72	857	1.41	1.89	917	1.54	2.07	975	1.69	2.26	1027	1.85	2.48
1890	4000	692	1.15	1.54	758	1.31	1.75	822	1.44	1.93	882	1.57	2.11	940	1.72	2.30	996	1.87	2.51	1047	2.06	2.76
2005	4250	722	1.31	1.76	787	1.47	1.97	849	1.60	2.15	908	1.75	2.35	965	1.91	2.56	1018	2.08	2.79	1067	2.28	3.06

Total Air Volume		TOTAL STATIC PRESSURE - Pa (Inches Water Gauge)																				
		400 (1.60)			450 (1.80)			500 (2.00)			550 (2.20)			600 (2.40)			650 (2.60)					
L/s	cfm	rev/min	kW	BHP	rev/min	kW	BHP	rev/min	kW	BHP	rev/min	kW	BHP	rev/min	kW	BHP	rev/min	kW	BHP	rev/min	kW	BHP
825	1750	961	0.89	1.19	---	---	---	---	---	---	---	---	---	---	---	---	---	---	---	---	---	---
945	2000	972	0.98	1.32	1026	1.10	1.47	1076	1.23	1.65	---	---	---	---	---	---	---	---	---	---	---	---
1060	2250	984	1.09	1.46	1037	1.22	1.63	1085	1.35	1.81	1132	1.50	2.01	1178	1.65	2.21	1226	1.81	2.43	---	---	---
1180	2500	997	1.21	1.62	1048	1.34	1.80	1096	1.48	1.99	1142	1.64	2.20	1188	1.80	2.41	1237	1.97	2.64	---	---	---
1300	2750	1011	1.34	1.80	1061	1.48	1.99	1108	1.63	2.19	1154	1.80	2.41	1200	1.96	2.63	1249	2.14	2.87	---	---	---
1415	3000	1026	1.48	1.99	1075	1.64	2.20	1121	1.81	2.42	1167	1.97	2.64	1213	2.14	2.87	1262	2.33	3.12	---	---	---
1535	3250	1042	1.65	2.21	1089	1.81	2.43	1135	1.98	2.66	1181	2.16	2.90	1228	2.33	3.13	1277	2.52	3.38	---	---	---
1650	3500	1058	1.84	2.46	1105	2.01	2.69	1150	2.19	2.93	1196	2.36	3.17	1243	2.54	3.41	1293	2.72	3.65	---	---	---
1770	3750	1076	2.03	2.72	1121	2.22	2.97	1166	2.40	3.22	1212	2.58	3.46	1261	2.77	3.71	1311	2.95	3.96	---	---	---
1890	4000	1094	2.25	3.02	1139	2.44	3.27	1184	2.63	3.52	1230	2.81	3.77	1280	3.01	4.03	1330	3.20	4.29	---	---	---
2005	4250	1113	2.48	3.33	1157	2.68	3.59	1202	2.87	3.85	1250	3.07	4.11	1300	3.27	4.38	1352	3.47	4.65	---	---	---

BLOWER DATA

120 STANDARD EFFICIENCY BELT DRIVE BLOWER – BASE UNIT

BLOWER TABLE INCLUDES RESISTANCE FOR BASE UNIT ONLY (NO HEAT SECTION) WITH DRY INDOOR COIL AND AIR FILTERS IN PLACE. FOR ALL UNITS ADD:

- 1 – Wet indoor coil air resistance of selected unit.
- 2 – Any factory installed options air resistance (heat section, economizer, etc.)
- 3 – Any field installed accessories air resistance (duct resistance, diffuser, etc.)

Then determine from blower table blower motor output required.

See page 20 for blower motors and drives.

See page 20 for wet coil and option/accessory air resistance data.

MINIMUM AIR VOLUME REQUIRED FOR USE WITH OPTIONAL ELECTRIC HEAT - Maximum Static Pressure - 500 Pa (2.0 in. w.g.)

11.5 kW, 17.2 kW - 975 L/s (2065 cfm)

23 kW - 1060 L/s (2250 cfm)

34.5 kW - 1240 L/s (2625 cfm)

45.9 kW - 1650 L/s (3500 cfm)

Total Air Volume		TOTAL STATIC PRESSURE - Pa (Inches Water Gauge)																				
		50 (0.20)			100 (0.40)			150 (0.60)			200 (0.80)			250 (1.00)			300 (1.20)			350 (1.40)		
L/s	cfm	rev/min	kW	BHP	rev/min	kW	BHP	rev/min	kW	BHP	rev/min	kW	BHP	rev/min	kW	BHP	rev/min	kW	BHP	rev/min	kW	BHP
945	2000	535	0.21	0.28	596	0.37	0.49	660	0.51	0.69	724	0.65	0.87	788	0.75	1.00	851	0.83	1.11	913	0.92	1.23
1060	2250	552	0.32	0.43	613	0.47	0.63	675	0.60	0.81	738	0.73	0.98	802	0.83	1.11	864	0.91	1.22	925	1.01	1.36
1180	2500	570	0.43	0.57	630	0.57	0.76	692	0.70	0.94	754	0.82	1.10	817	0.91	1.22	879	1.01	1.35	939	1.13	1.51
1300	2750	589	0.54	0.72	648	0.68	0.91	709	0.81	1.08	772	0.91	1.22	833	1.01	1.36	894	1.12	1.50	954	1.25	1.67
1415	3000	608	0.65	0.87	668	0.78	1.05	729	0.91	1.22	791	1.02	1.37	852	1.13	1.51	912	1.25	1.67	970	1.38	1.85
1535	3250	629	0.77	1.03	688	0.90	1.21	749	1.02	1.37	811	1.13	1.52	871	1.25	1.68	930	1.39	1.86	987	1.54	2.06
1650	3500	651	0.90	1.20	710	1.03	1.38	772	1.15	1.54	833	1.27	1.70	892	1.40	1.88	950	1.54	2.07	1004	1.70	2.28
1770	3750	674	1.01	1.36	734	1.16	1.56	796	1.29	1.73	856	1.42	1.90	914	1.57	2.10	970	1.72	2.30	1023	1.89	2.53
1890	4000	699	1.16	1.55	761	1.31	1.76	822	1.45	1.94	880	1.58	2.12	936	1.74	2.33	991	1.91	2.56	1042	2.10	2.81
2005	4250	726	1.32	1.77	789	1.48	1.98	849	1.61	2.16	904	1.77	2.37	959	1.93	2.59	1012	2.12	2.84	1062	2.32	3.11
2125	4500	756	1.50	2.01	818	1.66	2.22	875	1.80	2.41	929	1.96	2.63	983	2.15	2.88	1034	2.35	3.15	1082	2.57	3.44
2240	4750	788	1.69	2.27	848	1.84	2.47	902	2.00	2.68	955	2.18	2.92	1006	2.39	3.20	1056	2.61	3.50	1104	2.83	3.79
2360	5000	822	1.89	2.54	878	2.05	2.75	929	2.22	2.98	980	2.42	3.25	1031	2.66	3.56	1079	2.89	3.87	1126	3.10	4.16

Total Air Volume		TOTAL STATIC PRESSURE - Pa (Inches Water Gauge)																				
		400 (1.60)			450 (1.80)			500 (2.00)			550 (2.20)			600 (2.40)			650 (2.60)					
L/s	cfm	rev/min	kW	BHP	rev/min	kW	BHP	rev/min	kW	BHP	rev/min	kW	BHP	rev/min	kW	BHP	rev/min	kW	BHP	rev/min	kW	BHP
945	2000	971	1.02	1.37	1025	1.13	1.52	1076	1.26	1.69	1124	1.39	1.86	---	---	---	---	---	---	---	---	---
1060	2250	982	1.13	1.51	1036	1.25	1.68	1085	1.38	1.85	1133	1.52	2.04	1180	1.66	2.23	1228	1.82	2.44	1276	1.98	2.65
1180	2500	995	1.25	1.67	1047	1.38	1.85	1096	1.52	2.04	1143	1.66	2.23	1190	1.81	2.43	1239	1.98	2.65	1287	2.14	2.87
1300	2750	1009	1.38	1.85	1059	1.52	2.04	1108	1.67	2.24	1154	1.82	2.44	1202	1.98	2.65	1251	2.14	2.87	1300	2.30	3.08
1415	3000	1023	1.53	2.05	1073	1.68	2.25	1120	1.84	2.46	1167	1.99	2.67	1215	2.16	2.89	1265	2.32	3.11	1315	2.48	3.33
1535	3250	1039	1.69	2.27	1088	1.86	2.49	1134	2.01	2.70	1181	2.18	2.92	1229	2.34	3.14	1279	2.51	3.37	1330	2.67	3.58
1650	3500	1055	1.87	2.51	1103	2.04	2.74	1150	2.21	2.96	1196	2.38	3.19	1245	2.55	3.42	1295	2.72	3.65	1346	2.88	3.89
1770	3750	1072	2.07	2.78	1120	2.25	3.02	1166	2.42	3.25	1213	2.59	3.47	1262	2.77	3.71	1313	2.95	3.95	1364	3.11	4.19
1890	4000	1090	2.29	3.07	1137	2.47	3.31	1183	2.65	3.55	1231	2.82	3.78	1281	3.01	4.03	1333	3.19	4.28	1384	3.35	4.49
2005	4250	1109	2.52	3.38	1156	2.71	3.63	1202	2.89	3.87	1251	3.07	4.11	1302	3.26	4.37	1354	3.45	4.63	1405	3.61	4.84
2125	4500	1129	2.77	3.71	1175	2.95	3.96	1222	3.14	4.21	1271	3.33	4.46	1323	3.52	4.72	1376	3.73	5.00	1427	3.89	5.25
2240	4750	1150	3.03	4.06	1196	3.22	4.32	1243	3.41	4.57	1293	3.60	4.83	1345	3.80	5.09	1399	4.01	5.37	1450	4.17	5.56
2360	5000	1172	3.31	4.44	1218	3.51	4.70	1266	3.69	4.95	1315	3.88	5.20	1367	4.08	5.47	1421	4.28	5.74	1473	4.44	5.99

BLOWER DATA

150 STANDARD EFFICIENCY BELT DRIVE BLOWER – BASE UNIT

BLOWER TABLE INCLUDES RESISTANCE FOR BASE UNIT ONLY (NO HEAT SECTION) WITH DRY INDOOR COIL AND AIR FILTERS IN PLACE. FOR ALL UNITS ADD:

- 1 – Wet indoor coil air resistance of selected unit.
- 2 – Any factory installed options air resistance (heat section, economizer, etc.)
- 3 – Any field installed accessories air resistance (duct resistance, diffuser, etc.)

Then determine from blower table blower motor output required.

See page 20 for blower motors and drives.

See page 20 for wet coil and option/accessory air resistance data.

MINIMUM AIR VOLUME REQUIRED FOR USE WITH OPTIONAL ELECTRIC HEAT - Maximum Static Pressure - 500 Pa (2.0 in. w.g.)

11.5 kW, 17.2 kW - 975 L/s (2065 cfm)

23 kW - 1060 L/s (2250 cfm)

34.5 kW - 1240 L/s (2625 cfm)

45.9 kW - 1650 L/s (3500 cfm)

Total Air Volume		TOTAL STATIC PRESSURE - Pa (Inches Water Gauge)																				
		50 (0.20)			100 (0.40)			150 (0.60)			200 (0.80)			250 (1.00)			300 (1.20)			350 (1.40)		
L/s	cfm	rev/min	kW	BHP	rev/min	kW	BHP	rev/min	kW	BHP	rev/min	kW	BHP	rev/min	kW	BHP	rev/min	kW	BHP	rev/min	kW	BHP
945	2000	542	0.32	0.43	602	0.45	0.6	664	0.56	0.75	732	0.66	0.89	802	0.76	1.02	869	0.86	1.15	927	0.95	1.27
1060	2250	560	0.41	0.55	619	0.53	0.71	681	0.64	0.86	748	0.75	1.00	817	0.85	1.14	882	0.95	1.27	939	1.05	1.41
1180	2500	579	0.51	0.68	637	0.62	0.83	699	0.73	0.98	766	0.84	1.12	834	0.94	1.26	897	1.05	1.41	953	1.17	1.57
1300	2750	599	0.60	0.81	657	0.72	0.97	719	0.83	1.11	785	0.93	1.25	851	1.05	1.41	913	1.17	1.57	968	1.30	1.74
1415	3000	620	0.71	0.95	678	0.83	1.11	741	0.93	1.25	806	1.04	1.40	870	1.18	1.58	930	1.31	1.75	985	1.45	1.94
1535	3250	643	0.82	1.10	701	0.94	1.26	764	1.05	1.41	828	1.17	1.57	891	1.31	1.76	950	1.45	1.95	1003	1.61	2.16
1650	3500	667	0.94	1.26	726	1.07	1.43	788	1.18	1.58	851	1.32	1.77	913	1.47	1.97	970	1.62	2.17	1023	1.80	2.41
1770	3750	693	1.07	1.44	752	1.20	1.61	813	1.33	1.78	876	1.48	1.98	936	1.64	2.20	992	1.81	2.43	1043	2.00	2.68
1890	4000	720	1.23	1.65	779	1.36	1.82	840	1.49	2.00	902	1.66	2.22	961	1.84	2.46	1015	2.02	2.71	1064	2.22	2.98
2005	4250	748	1.39	1.86	807	1.52	2.04	868	1.67	2.24	929	1.85	2.48	986	2.05	2.75	1038	2.25	3.02	1086	2.46	3.3
2125	4500	778	1.56	2.09	837	1.70	2.28	898	1.87	2.51	957	2.07	2.78	1012	2.29	3.07	1062	2.51	3.37	1108	2.72	3.65
2240	4750	809	1.75	2.34	868	1.91	2.56	929	2.10	2.82	986	2.33	3.12	1038	2.56	3.43	1087	2.79	3.74	1132	3.01	4.03
2360	5000	841	1.95	2.62	901	2.14	2.87	960	2.36	3.17	1015	2.61	3.50	1065	2.86	3.83	1112	3.09	4.14	1157	3.30	4.43
2475	5250	875	2.19	2.93	935	2.41	3.23	992	2.66	3.56	1044	2.92	3.91	1092	3.18	4.26	1138	3.41	4.57	1182	3.62	4.85
2595	5500	911	2.46	3.30	969	2.71	3.63	1024	2.98	4.00	1074	3.26	4.37	1120	3.51	4.71	1165	3.74	5.02	1208	3.95	5.29
2715	5750	948	2.77	3.71	1004	3.04	4.08	1056	3.34	4.48	1104	3.62	4.85	1148	3.87	5.19	1192	4.10	5.49	1235	4.28	5.74
2830	6000	985	3.12	4.18	1039	3.42	4.59	1088	3.73	5.00	1134	4.01	5.37	1177	4.24	5.69	---	---	---	---	---	---
2950	6250	1022	3.51	4.70	1073	3.83	5.14	1120	4.13	5.54	---	---	---	---	---	---	---	---	---	---	---	---

Total Air Volume		TOTAL STATIC PRESSURE - Pa (Inches Water Gauge)																				
		400 (1.60)			450 (1.80)			500 (2.00)			550 (2.20)			600 (2.40)			650 (2.60)					
L/s	cfm	rev/min	kW	BHP	rev/min	kW	BHP	rev/min	kW	BHP	rev/min	kW	BHP	rev/min	kW	BHP	rev/min	kW	BHP	rev/min	kW	BHP
945	2000	979	1.05	1.41	1029	1.17	1.57	1079	1.31	1.75	1129	1.45	1.95	1179	1.60	2.15	1230	1.77	2.37	---	---	---
1060	2250	991	1.17	1.57	1041	1.30	1.74	1090	1.44	1.93	1140	1.59	2.13	1190	1.75	2.35	1241	1.92	2.57	---	---	---
1180	2500	1005	1.30	1.74	1054	1.43	1.92	1103	1.58	2.12	1152	1.74	2.33	1202	1.90	2.55	1254	2.08	2.79	---	---	---
1300	2750	1020	1.44	1.93	1068	1.59	2.13	1116	1.75	2.34	1165	1.91	2.56	1215	2.07	2.78	1268	2.25	3.01	---	---	---
1415	3000	1036	1.60	2.14	1084	1.76	2.36	1131	1.92	2.58	1180	2.09	2.80	1230	2.25	3.02	1283	2.43	3.26	---	---	---
1535	3250	1053	1.78	2.38	1100	1.95	2.61	1148	2.11	2.83	1196	2.28	3.06	1246	2.45	3.29	1299	2.63	3.52	---	---	---
1650	3500	1071	1.98	2.65	1118	2.15	2.88	1165	2.32	3.11	1213	2.48	3.33	1264	2.66	3.57	1317	2.84	3.81	---	---	---
1770	3750	1091	2.19	2.93	1137	2.36	3.17	1183	2.54	3.40	1232	2.72	3.64	1284	2.89	3.88	1338	3.08	4.13	---	---	---
1890	4000	1111	2.42	3.24	1156	2.60	3.48	1203	2.78	3.72	1253	2.95	3.96	1305	3.15	4.22	1359	3.34	4.48	---	---	---
2005	4250	1132	2.66	3.57	1177	2.84	3.81	1224	3.02	4.05	1274	3.22	4.31	1327	3.41	4.57	1382	3.62	4.85	---	---	---
2125	4500	1154	2.92	3.92	1199	3.11	4.17	1247	3.29	4.41	1297	3.48	4.67	1350	3.69	4.94	1405	3.89	5.22	---	---	---
2240	4750	1177	3.20	4.29	1223	3.39	4.54	1270	3.57	4.79	1321	3.76	5.04	1374	3.96	5.31	1428	4.16	5.58	---	---	---
2360	5000	1201	3.50	4.69	1247	3.69	4.94	1295	3.86	5.18	1345	4.04	5.42	1398	4.24	5.68	---	---	---	---	---	---
2475	5250	1226	3.80	5.10	1272	3.98	5.34	1320	4.16	5.57	---	---	---	---	---	---	---	---	---	---	---	---
2595	5500	1253	4.13	5.53	---	---	---	---	---	---	---	---	---	---	---	---	---	---	---	---	---	---

BLOWER DATA

FACTORY INSTALLED BELT DRIVE KIT SPECIFICATIONS

Nominal		Maximum		Drive Kit Number	Rev/Min Range
kW	hp	kW	hp		
1.5	2	1.7	2.3	1	490 - 740
1.5	2	1.7	2.3	2	665 - 920
1.5	2	1.7	2.3	3	660 - 995
2.2	3	2.6	3.45	7	610 - 810
2.2	3	2.6	3.45	8	780 - 1000
2.2	3	2.6	3.45	9	845 - 1085
3.7	5	4.3	5.75	10	750 - 945
3.7	5	4.3	5.75	11	865 - 1095
3.7	5	4.3	5.75	12	940 - 1190

NOTE - Using total air volume and system static pressure requirements determine from blower performance tables rev/min and motor output required. Maximum usable output of motors furnished are shown. If motors of comparable output are used, be sure to keep within the service factor limitations outlined on the motor nameplate.

POWER EXHAUST FAN PERFORMANCE

Return Air System Static Pressure		Air Volume Exhausted	
Pa	in. w.g.	L/s	cfm
0	0	1687	3575
12	0.05	1607	3405
25	0.10	1675	3550
37	0.15	1531	3245
50	0.20	1470	3115
62	0.25	1425	3020
75	0.30	1369	2900
87	0.35	1314	2785

FACTORY INSTALLED OPTIONS/FIELD INSTALLED ACCESSORY AIR RESISTANCE

Air Volume		Wet Indoor Coil						Electric Heat		Economizer		Filters			
		092		102, 120		150						MERV 8		MERV 13	
L/s	cfm	Pa	in. w.g.	Pa	in. w.g.	Pa	in. w.g.	Pa	in. w.g.	Pa	in. w.g.	Pa	in. w.g.	Pa	in. w.g.
825	1750	5	0.02	7	0.03	10	0.04	7	0.03	7	0.03	2	0.01	7	0.03
945	2000	5	0.02	10	0.04	12	0.05	7	0.03	12	0.05	2	0.01	7	0.03
1060	2250	7	0.03	12	0.05	15	0.06	10	0.04	15	0.06	2	0.01	10	0.04
1180	2500	7	0.03	12	0.05	17	0.07	10	0.04	20	0.08	2	0.01	12	0.05
1300	2750	10	0.04	15	0.06	20	0.08	12	0.05	22	0.09	5	0.02	12	0.05
1415	3000	12	0.05	17	0.07	22	0.09	15	0.06	27	0.11	5	0.02	15	0.06
1535	3250	12	0.05	20	0.08	25	0.10	15	0.06	32	0.13	5	0.02	15	0.06
1650	3500	15	0.06	22	0.09	27	0.11	22	0.09	37	0.15	7	0.03	17	0.07
1770	3750	17	0.07	25	0.10	32	0.13	22	0.09	42	0.17	7	0.03	20	0.08
1890	4000	17	0.07	27	0.11	35	0.14	22	0.09	47	0.19	10	0.04	20	0.08
2005	4250	20	0.08	32	0.13	37	0.15	32	0.13	52	0.21	10	0.04	22	0.09
2125	4500	22	0.09	35	0.14	42	0.17	35	0.14	60	0.24	10	0.04	22	0.09
2240	4750	25	0.10	37	0.15	45	0.18	42	0.17	65	0.26	12	0.05	25	0.10
2360	5000	25	0.10	40	0.16	50	0.20	50	0.20	72	0.29	15	0.06	25	0.10
2475	5250	27	0.11	42	0.17	55	0.22	55	0.22	80	0.32	15	0.06	27	0.11
2595	5500	30	0.12	47	0.19	57	0.23	62	0.25	85	0.34	17	0.07	30	0.12
2715	5750	32	0.13	50	0.20	62	0.25	77	0.31	92	0.37	17	0.07	30	0.12
2830	6000	35	0.14	55	0.22	67	0.27	82	0.33	99	0.40	20	0.08	32	0.13

BLOWER DATA

CEILING DIFFUSERS AIR RESISTANCE

Unit Size	RTD11 Step-Down Diffuser								FD11 Flush Diffuser	
	Air Volume		2 Ends Open		1 Side, 2 Ends Open		All Ends & Sides Open			
	Pa	in. w.g.	Pa	in. w.g.	Pa	in. w.g.	Pa	in. w.g.	Pa	in. w.g.
092 Models	1133	2400	52	0.21	45	0.18	37	0.15	35	0.14
	1227	2600	60	0.24	52	0.21	45	0.18	42	0.17
	1321	2800	67	0.27	60	0.24	52	0.21	50	0.20
	1416	3000	80	0.32	72	0.29	62	0.25	62	0.25
	1510	3200	102	0.41	92	0.37	80	0.32	77	0.31
	1604	3400	124	0.50	112	0.45	97	0.39	92	0.37
	1699	3600	152	0.61	134	0.54	119	0.48	109	0.44
102 & 120 Models	1793	3800	182	0.73	157	0.63	142	0.57	127	0.51
	1699	3600	90	0.36	70	0.28	57	0.23	37	0.15
	1793	3800	99	0.40	80	0.32	65	0.26	45	0.18
	1888	4000	109	0.44	90	0.36	72	0.29	52	0.21
	1982	4200	122	0.49	99	0.40	82	0.33	60	0.24
	2076	4400	134	0.54	109	0.44	92	0.37	67	0.27
	2171	4600	149	0.60	122	0.49	104	0.42	77	0.31
	2265	4800	162	0.65	132	0.53	114	0.46	87	0.35
150 Models	2360	5000	172	0.69	144	0.58	124	0.50	97	0.39
	2454	5200	186	0.75	154	0.62	134	0.54	107	0.43
	1982	4200	55	0.22	47	0.19	40	0.16	25	0.10
	2076	4400	70	0.28	60	0.24	50	0.20	30	0.12
	2171	4600	85	0.34	72	0.29	60	0.24	37	0.15
	2265	4800	99	0.40	85	0.34	72	0.29	47	0.19
	2360	5000	114	0.46	97	0.39	85	0.34	57	0.23
	2454	5200	129	0.52	109	0.44	97	0.39	67	0.27
	2548	5400	144	0.58	122	0.49	107	0.43	77	0.31
2643	5600	159	0.64	134	0.54	117	0.47	87	0.35	
2737	5800	174	0.70	147	0.59	127	0.51	97	0.39	

CEILING DIFFUSER AIR THROW DATA

Model No.	Air Volume		¹ Effective Throw Range			
			RTD11 Step-Down		FD11 Flush	
	L/s	cfm	m	ft.	m	ft.
092 Models	1225	2600	7 - 9	24 - 29	6 - 7	19 - 24
	1320	2800	8 - 9	25 - 30	6 - 9	20 - 28
	1415	3000	8 - 10	27 - 33	6 - 9	21 - 29
	1510	3200	9 - 11	28 - 35	7 - 9	22 - 29
	1605	3400	9 - 11	30 - 37	7 - 9	22 - 30
102, 120 Models	1700	3600	8 - 10	25 - 33	7 - 9	22 - 29
	1795	3800	8 - 11	27 - 35	7 - 9	22 - 30
	1890	4000	9 - 11	29 - 37	7 - 10	24 - 33
	1980	4200	10 - 12	32 - 40	8 - 11	26 - 35
	2075	4400	10 - 13	34 - 42	9 - 11	28 - 37
150 Models	2645	5600	12 - 15	39 - 49	9 - 11	28 - 37
	2735	5800	13 - 16	42 - 51	9 - 12	29 - 38
	2830	6000	13 - 17	44 - 54	12 - 15	40 - 50
	2925	6200	14 - 17	45 - 55	13 - 16	42 - 51
	3020	6400	14 - 17	46 - 55	13 - 16	43 - 52
3115	6600	14 - 17	47 - 56	14 - 17	45 - 56	

¹ Throw is the horizontal or vertical distance an air stream travels on leaving the outlet or diffuser before the maximum velocity is reduced to 15 m (50 ft.) per minute. Four sides open.

ELECTRICAL/ELECTRIC HEAT DATA

Model No.		ZCB092S4			ZCB102S4		
¹ Voltage - 50hz 3 Phase with neutral		380/420V			380/420V		
Compressor 1	Rated Load Amps	8			8		
	Locked Rotor Amps	59			59		
Compressor 2	Rated Load Amps	4			5.5		
	Locked Rotor Amps	31			37		
Outdoor Fan Motors (2)	Full Load Amps	1.3			1.3		
	(total)	(2.6)			(2.6)		
Power Exhaust (2) 0.33 kW (0.5 hp)	Full Load Amps	1.7			1.7		
		(3.4)			(3.4)		
Indoor Blower Motor	kW	1.5	2.2	3.7	1.5	2.2	3.7
	Full Load Amps	3.6	5.3	8.2	3.6	5.3	8.2
² Maximum Overcurrent Protection	Unit Only	25	25	30	25	30	30
	With (2) 0.33 kW (0.5 hp) Power Exhaust	30	30	35	30	30	35
³ Minimum Circuit Ampacity	Unit Only	21	22	25	22	24	27
	With (2) 0.33 kW (0.5 hp) Power Exhaust	24	26	29	26	27	30

ELECTRIC HEAT DATA

Electric Heat Voltage			420V	420V	420V	420V	420V	420V
² Maximum Overcurrent Protection	Unit+ ⁴ Electric Heat	5.7 kW	25	25	30	25	30	30
		11.5 kW	25	30	30	25	30	30
		17.2 kW	35	40	40	35	40	40
		23 kW	45	50	50	45	50	50
		34.5 kW	70	70	70	70	70	70
³ Minimum Circuit Ampacity	Unit+ ⁴ Electric Heat	5.7 kW	21	22	25	22	24	27
		11.5 kW	25	27	30	25	27	30
		17.2 kW	35	37	40	35	37	40
		23 kW	44	47	50	44	47	50
		34.5 kW	64	66	70	64	66	70
² Maximum Overcurrent Protection	Unit+ ⁴ Electric Heat and (2) 0.33 kW (0.5 hp) Power Exhaust	5.7 kW	30	30	35	30	30	35
		11.5 kW	30	35	35	30	35	35
		17.2 kW	40	45	45	40	45	45
		23 kW	50	60	60	50	60	60
		34.5 kW	70	80	80	70	80	80
³ Minimum Circuit Ampacity	Unit+ ⁴ Electric Heat and (2) 0.33 kW (0.5 hp) Power Exhaust	5.7 kW	24	26	29	26	27	30
		11.5 kW	29	31	35	29	31	35
		17.2 kW	39	41	45	39	41	45
		23 kW	49	51	54	49	51	54
		34.5 kW	68	71	74	68	71	74

ELECTRIC HEAT ACCESSORIES

Unit Fuse Block	Unit Only	10Z39	10Z39	10Z39	10Z39	10Z39	10Z39
	Unit + Power Exhaust	10Z39	10Z39	10Z40	10Z39	10Z39	10Z40

¹ Extremes of operating range are plus and minus 10% of line voltage.

² Heating / Air Conditioning / Refrigeration (HACR) type breaker or fuse.

³ Refer to local codes to determine wire, fuse and disconnect size requirements.

⁴ Nominal kW based on 420V-3ph-50hz.

ELECTRICAL/ELECTRIC HEAT DATA

Model No.		ZCB120S4			ZCB150S4		
¹ Voltage - 50hz 3 Phase with neutral		380/420V			380/420V		
Compressor 1	Rated Load Amps	8			8		
	Locked Rotor Amps	59			67.1		
Compressor 2	Rated Load Amps	8			10.6		
	Locked Rotor Amps	59			74		
Outdoor Fan Motors (2)	Full Load Amps	1.3			1.5		
	(total)	(2.6)			(3)		
Power Exhaust (2) 0.33 kW (0.5 hp)	Full Load Amps	1.7			1.7		
		(3.4)			(3.4)		
Indoor Blower Motor	kW	1.5	2.2	3.7	1.5	2.2	3.7
	Full Load Amps	3.6	5.3	8.2	3.6	5.3	8.2
² Maximum Overcurrent Protection	Unit Only	30	30	35	35	40	40
	With (2) 0.33 kW (0.5 hp) Power Exhaust	35	35	40	40	40	45
³ Minimum Circuit Ampacity	Unit Only	25	26	29	28	30	33
	With (2) 0.33 kW (0.5 hp) Power Exhaust	28	30	33	32	33	36

ELECTRIC HEAT DATA

Electric Heat Voltage			420V	420V	420V	420V	420V	420V
² Maximum Overcurrent Protection	Unit+	11.5 kW	30	30	35	35	40	40
	⁴ Electric Heat	17.2 kW	35	40	40	35	40	40
		23 kW	45	50	50	45	50	50
		34.5 kW	70	70	70	70	70	70
		45.9 kW	70	70	80	70	70	80
³ Minimum Circuit Ampacity	Unit+	11.5 kW	25	27	30	28	30	33
	⁴ Electric Heat	17.2 kW	35	37	40	35	37	40
		23 kW	44	47	50	44	47	50
		34.5 kW	64	66	70	64	66	70
		45.9 kW	68	70	74	68	70	74
² Maximum Overcurrent Protection	Unit+	11.5 kW	35	35	40	40	40	45
	⁴ Electric Heat and (2) 0.33 kW (0.5 hp) Power Exhaust	17.2 kW	40	45	45	40	45	45
		23 kW	50	60	60	50	60	60
		34.5 kW	70	80	80	70	80	80
		45.9 kW	80	80	80	80	80	80
³ Minimum Circuit Ampacity	Unit+	11.5 kW	29	31	35	32	33	36
	⁴ Electric Heat and (2) 0.33 kW (0.5 hp) Power Exhaust	17.2 kW	39	41	45	39	41	45
		23 kW	49	51	54	49	51	54
		34.5 kW	68	71	74	68	71	74
		45.9 kW	72	75	78	72	75	78

ELECTRIC HEAT ACCESSORIES

Unit Fuse Block	Unit Only	10Z39	10Z39	10Z40	10Z39	10Z39	10Z40
	Unit + Power Exhaust	10Z40	10Z40	10Z40	10Z40	10Z40	10Z40

¹ Extremes of operating range are plus and minus 10% of line voltage.

² Heating / Air Conditioning / Refrigeration (HACR) type breaker or fuse.

³ Refer to local codes to determine wire, fuse and disconnect size requirements.

⁴ Nominal kW based on 420V-3ph-50hz.

ELECTRIC HEAT CAPACITIES

Volts Input	5.7 kW			11.5 kW			17.2 kW			23 kW			34.5 kW			45.9 kW		
	kW Input	Btuh Output	No. of Stages	kW Input	Btuh Output	No. of Stages	kW Input	Btuh Output	No. of Stages	kW Input	Btuh Output	No. of Stages	kW Input	Btuh Output	No. of Stages	kW Input	Btuh Output	No. of Stages
380	4.7	16 000	1	9.4	32 100	1	14.1	48 200	1	18.8	64 200	2	28.2	96 300	2	37.6	128 400	2
400	5.2	17 800	1	10.4	35 500	1	15.6	53 300	1	20.9	71 400	2	31.2	106 600	2	41.6	142 100	2
420	5.7	19 500	1	11.5	39 300	1	17.2	58 700	1	23	78 500	2	34.5	117 500	2	45.9	156 800	2

UNIT CLEARANCES

UNIT WITH ECONOMIZER

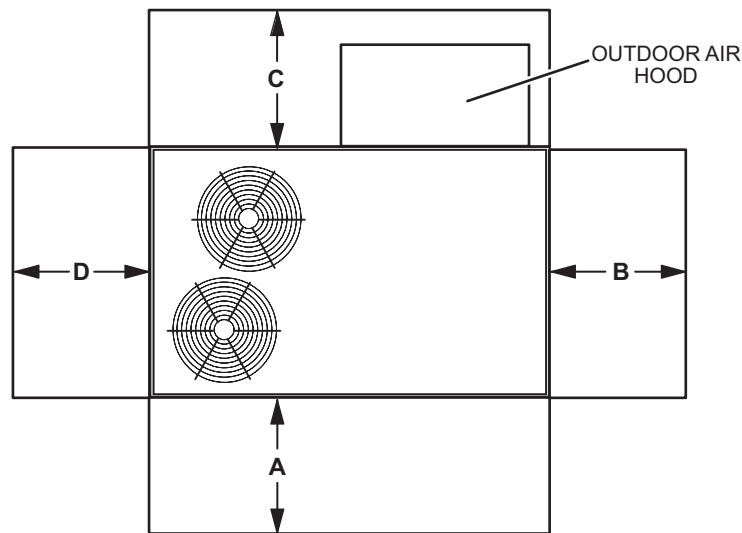

¹ Unit Clearance	A		B		C		D		Top Clearance
	mm	in.	mm	in.	mm	in.	mm	in.	
Service Clearance	1524	60	914	36	914	36	1524	60	Unobstructed
Minimum Operation Clearance	914	36	914	36	914	36	914	36	

NOTE - Entire perimeter of unit base requires support when elevated above the mounting surface.

¹ Service Clearance - Required for removal of serviceable parts.

Minimum Operation Clearance - Required clearance for proper unit operation.

OUTDOOR SOUND DATA

Unit Model Number	Octave Band Linear Sound Power Levels dB, re 10 ⁻¹² Watts - Center Frequency - Hz							¹ Sound Rating Number (SRN) (dBA)
	125	250	500	1000	2000	4000	8000	
092, 102 and 120	72	74	79	80	76	70	63	84
150	76	81	87	86	80	77	76	91

¹ Sound Rating Number according to ARI Standard 270-2008. "SRN" is the overall A-Weighted Sound Power Level, (LWA), dB (100 Hz to 10,000 Hz).

WEIGHT DATA

Model Number	Net		Shipping	
	kg	lbs.	kg	lbs.
092 Base Unit	387	854	426	939
092 Max. Unit	459	1011	497	1096
102 Base Unit	396	874	435	959
102 Max. Unit	468	1031	506	1116
120 Base Unit	415	914	453	999
120 Max. Unit	489	1078	528	1163
150 Base Unit	455	1004	494	1089
150 Max. Unit	530	1168	568	1253

OPTIONS / ACCESSORIES

Model Number	Shipping Weight	
	kg	lbs.

CABINET

Coil/Hail Guard	23	50
-----------------	----	----

CEILING DIFFUSERS

Step-Down		
RTD11-95S	118	54
RTD11-135S	135	61
RTD11-185S	168	76
Flush		
FD11-95S	118	54
FD11-135S	135	61
FD11-185S	168	76

ECONOMIZER / OUTDOOR AIR / EXHAUST

Economizer		
Downflow with Barometric Relief Dampers and Hoods	41	90
Horizontal with Barometric Relief Dampers and Hoods	43	95
Horizontal Low Profile Barometric Relief Dampers with Hood	4	8

Outdoor Air Dampers

Outdoor Air Damper Section with Hood - Automatic	26	58
Outdoor Air Damper Section with Hood - Manual	23	50

Power Exhaust

Downflow	27	60
Horizontal	19	41

ELECTRIC HEAT

5.7 kW	41	90
11.5 kW	41	90
17.2 kW	41	90
23 kW	41	90
34.5 kW	41	90
45.9 kW	41	90

ROOF CURBS

Hybrid Roof Curbs, Downflow		
203 mm height	36	79
356 mm height	47	104
457 mm height	54	120
610 mm height	66	145

PACKAGING

LTL Packaging (less than truck load)	48	105
--------------------------------------	----	-----

DIMENSIONS - UNIT

Model No.	CORNER WEIGHTS																CENTER OF GRAVITY							
	AA				BB				CC				DD				EE				FF			
	Base		Max		Base		Max		Base		Max		Base		Max		Base		Max		Base		Max	
	kg	lbs.	kg	lbs.	kg	lbs.	kg	lbs.	kg	lbs.	kg	lbs.	kg	lbs.	kg	lbs.	mm	in.	mm	in.	mm	in.	mm	in.
092	111	244	130	287	82	181	103	227	83	182	100	220	112	247	126	278	1207	47.5	1232	48.5	648	25.5	673	26.5
102	113	250	133	293	84	185	105	231	85	187	102	224	114	252	128	283	1207	47.5	1232	48.5	648	25.5	673	26.5
120	119	262	139	306	88	193	110	242	88	195	106	234	120	264	134	296	1207	47.5	1232	48.5	648	25.5	673	26.5
150	130	287	150	332	96	212	119	262	97	214	115	254	131	290	145	321	1207	47.5	1232	48.5	648	25.5	673	26.5

Base Unit - The unit with NO OPTIONS.

Max. Unit - The unit with ALL OPTIONS Installed. (Economizer, etc.)

BOTTOM POWER ENTRY

Holes required for Optional Bottom Power Entry Kit

	Threaded Conduit Fittings (Provided in Kit)	Wire Use	Hole Diameter Required in Unit Base (Max.)
A	1 1/2 in.	ACC	23 (7/8)
B	1/2 in.	24V	23 (7/8)
C	1-1/4 in.	POWER	44 (1-3/4)

¹ Field provided.

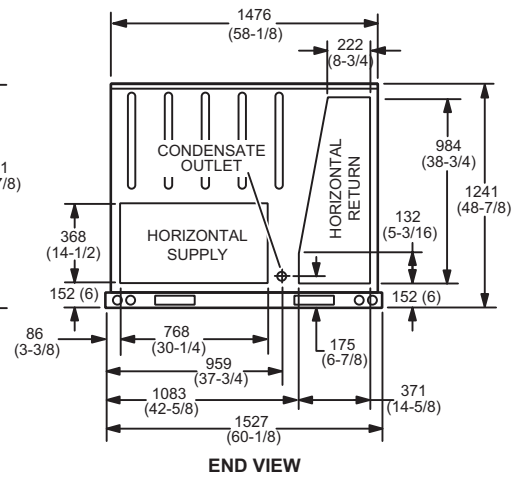
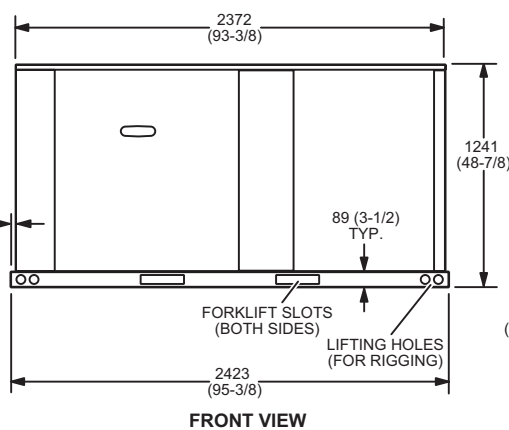
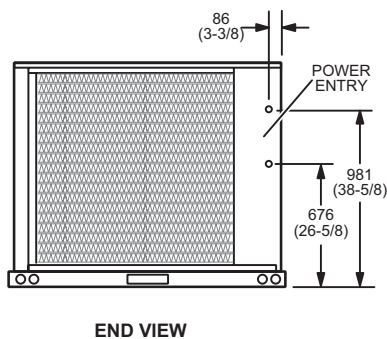
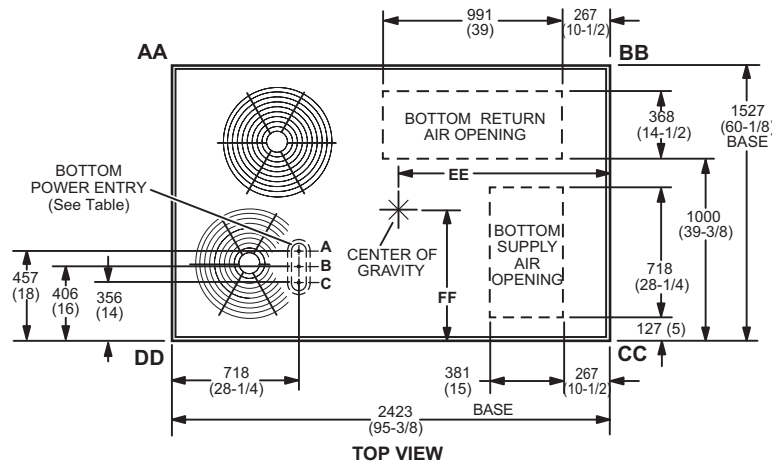

DIMENSIONS - ACCESSORIES

OUTDOOR AIR HOOD DETAIL FOR OPTIONAL DOWNFLOW ECONOMIZER (Downflow Applications)

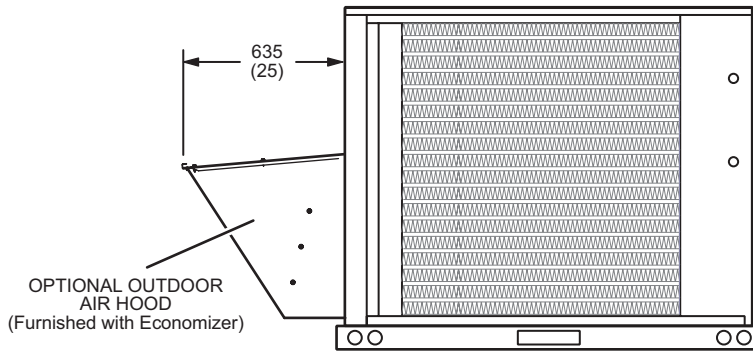

END VIEW

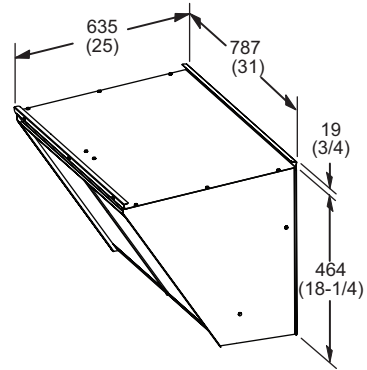

OUTDOOR AIR DAMPER HOOD DETAIL FOR OPTIONAL MANUAL OR MOTORIZED OUTDOOR AIR DAMPERS (Downflow or Horizontal Applications)

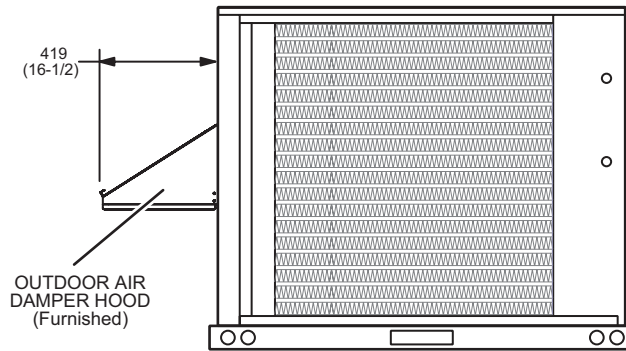

END VIEW

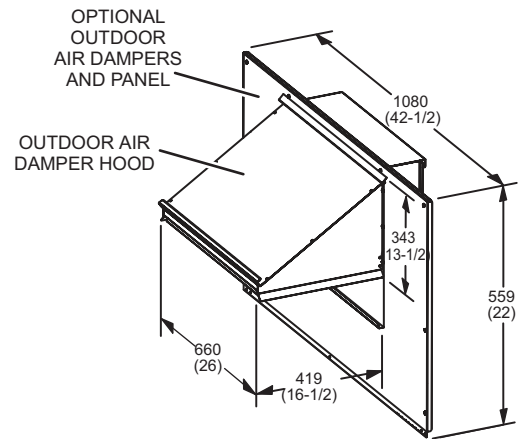

DIMENSIONS - ACCESSORIES

OUTDOOR AIR HOOD DETAIL WITH OPTIONAL HORIZONTAL ECONOMIZER AND BAROMETRIC RELIEF DAMPERS (Horizontal Applications)

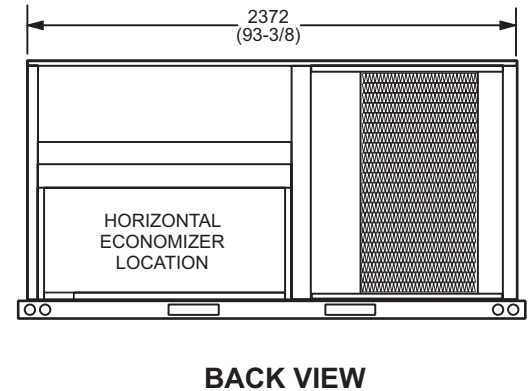
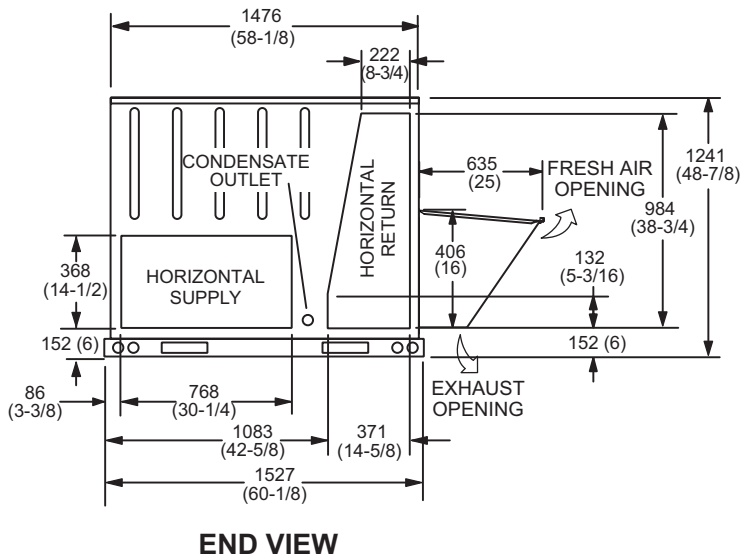
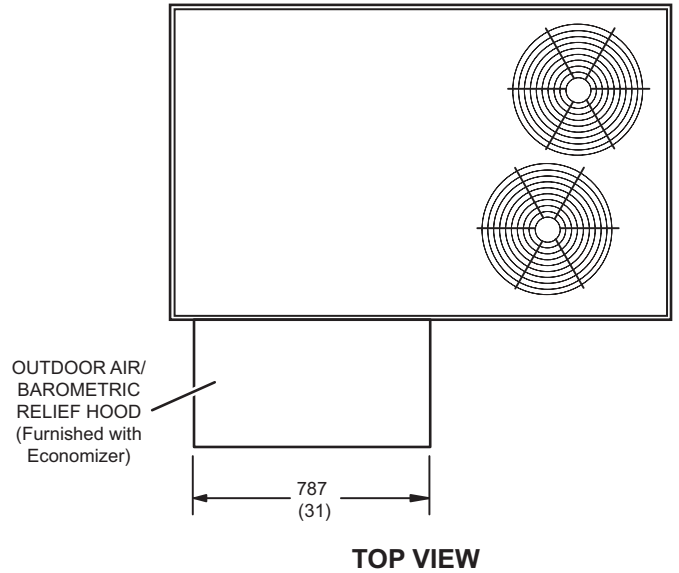

Note - Supply and Return Air Ducts must be supported.

DIMENSIONS - ACCESSORIES

HYBRID CURBS - DOUBLE DUCT OPENING

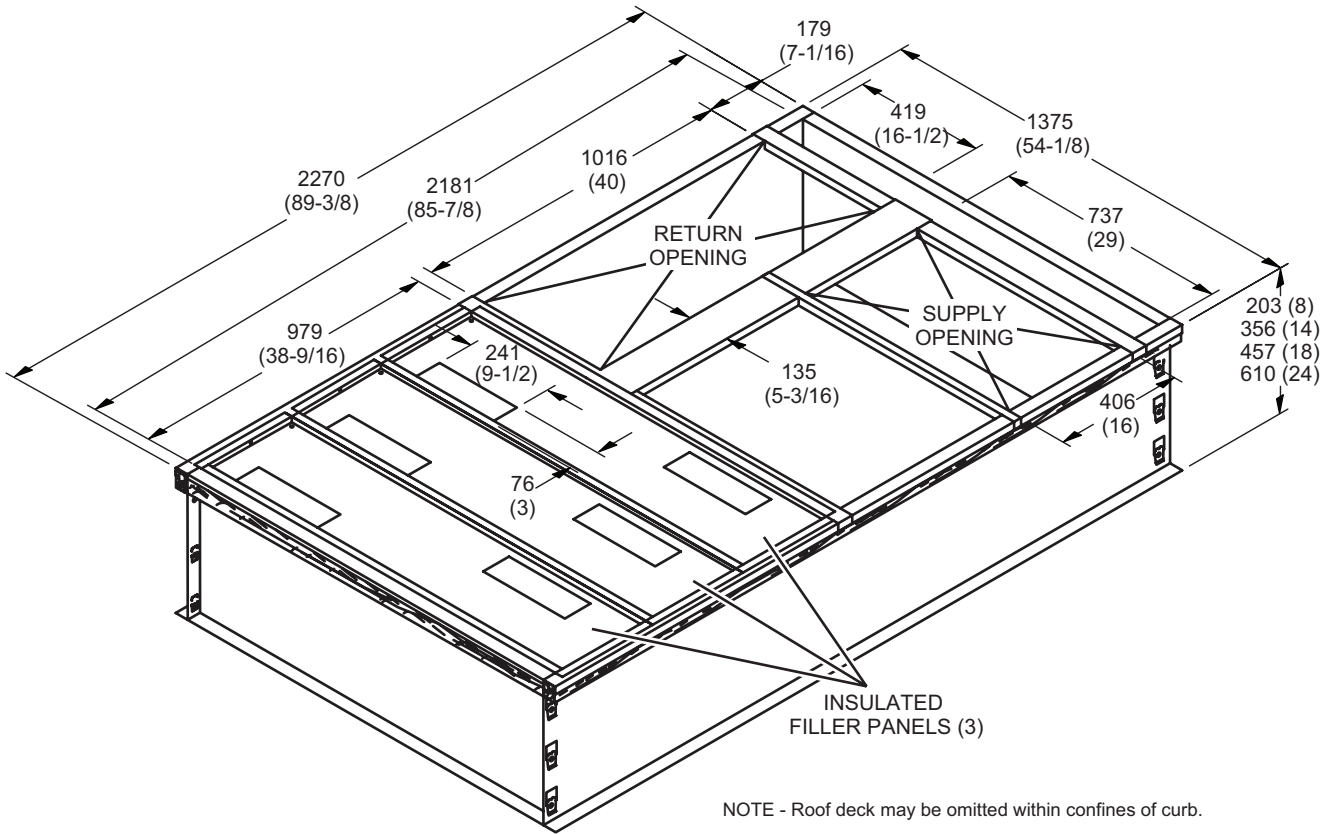

TYPICAL FLASHING DETAIL FOR ROOF CURB

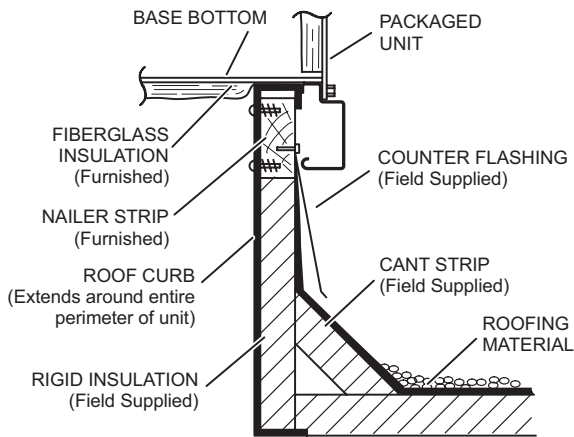

DETAIL ROOF CURB

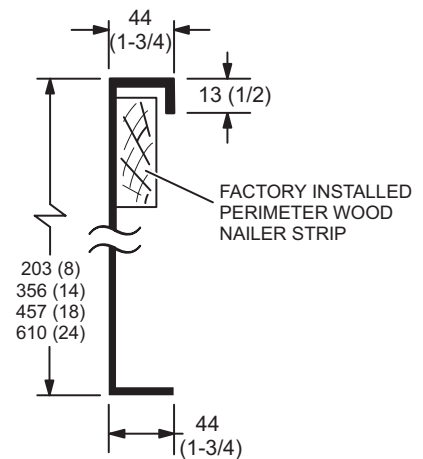

DIMENSIONS - ACCESSORIES

COMBINATION CEILING SUPPLY AND RETURN DIFFUSERS

STEP-DOWN CEILING DIFFUSER

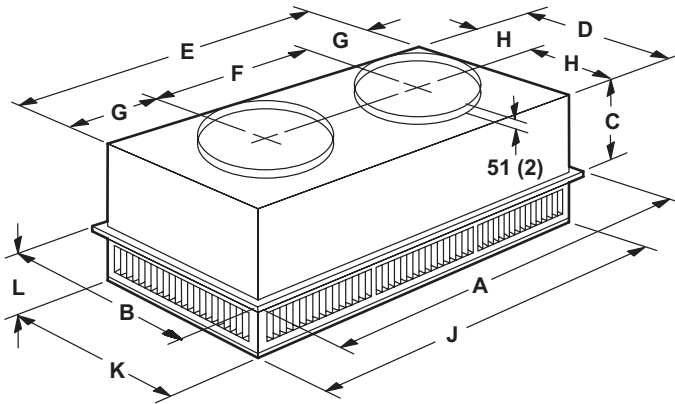

FLUSH CEILING DIFFUSER

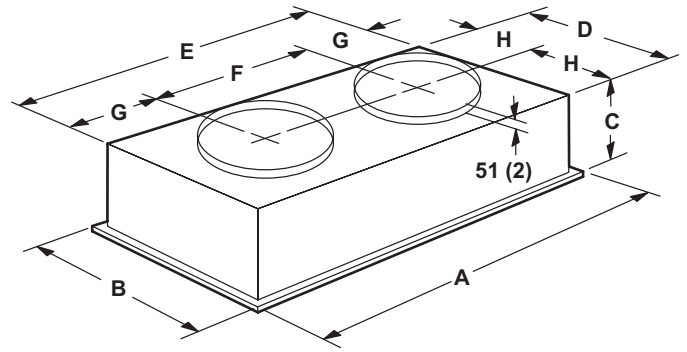

Model Number		RTD11-95S
A	mm	1159
	in.	47-5/8
B	mm	752
	in.	29-5/8
C	mm	365
	in.	14-3/8
D	mm	699
	in.	27-1/2
E	mm	1158
	in.	45-1/2
F	mm	572
	in.	22-1/2
G	mm	292
	in.	11-1/2
H	mm	349
	in.	13-3/4
J	mm	1156
	in.	45-1/2
K	mm	699
	in.	27-1/2
L	mm	206
	in.	8-1/8
Duct Size	mm	508 round
	in.	20 round

Model Number		FD11-95S
A	mm	1159
	in.	47-5/8
B	mm	752
	in.	29-5/8
C	mm	422
	in.	16-5/8
D	mm	686
	in.	27
E	mm	1143
	in.	45
F	mm	572
	in.	22-1/2
G	mm	286
	in.	11-1/4
H	mm	343
	in.	13-1/2
Duct Size	mm	508 round
	in.	20 round

DIMENSIONS - ACCESSORIES

COMBINATION CEILING SUPPLY AND RETURN DIFFUSERS

STEP-DOWN CEILING DIFFUSER

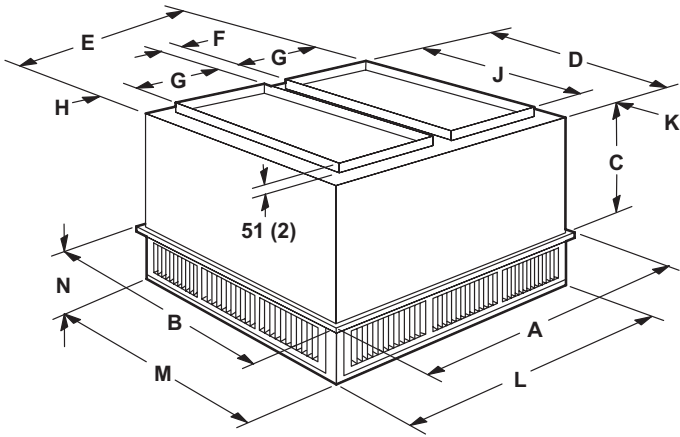

FLUSH CEILING DIFFUSER

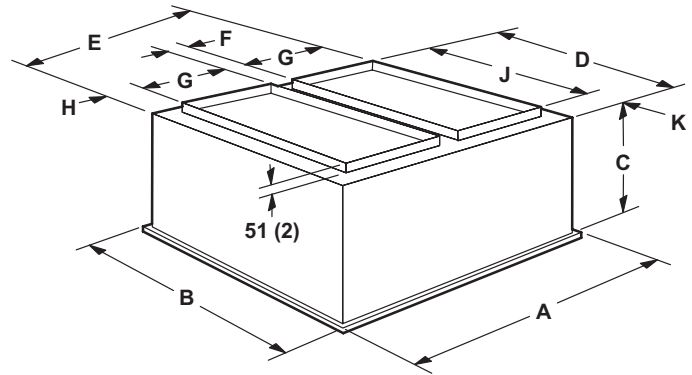

Model Number		RTD11-135S	RTD11-185S
A	mm	1210	1210
	in.	47-5/8	47-5/8
B	mm	905	1210
	in.	35-5/8	47-5/8
C	mm	524	625
	in.	20-5/8	24-5/8
D	mm	851	1156
	in.	33-1/2	45-1/2
E	mm	45-1/2	45-1/2
	in.	1156	1156
F	mm	114	114
	in.	4-1/2	4-1/2
G	mm	457	457
	in.	18	18
H	mm	64	64
	in.	2-1/2	2-1/2
J	mm	711	914
	in.	28	36
K	mm	70	121
	in.	2-3/4	4-3/4
L	mm	1156	1156
	in.	45-1/2	45-1/2
M	mm	851	1156
	in.	33-1/2	45-1/2
N	mm	232	257
	in.	9-1/8	10-1/8
Duct Size	mm	457 x 711	457 x 914
	in.	18 x 28	18 x 36

Model Number		FD11-135S	FD11-185S
A	mm	1210	1210
	in.	47-5/8	47-5/8
B	mm	905	1210
	in.	35-5/8	47-5/8
C	mm	591	743
	in.	23-1/4	29-1/4
D	mm	838	1143
	in.	33	45
E	mm	1143	1143
	in.	45	45
F	mm	114	114
	in.	4-1/2	4-1/2
G	mm	457	457
	in.	18	18
H	mm	57	57
	in.	2-1/4	2-1/4
J	mm	711	914
	in.	28	36
K	mm	64	114
	in.	2-1/2	4-1/2
Duct Size	mm	457 x 711	457 x 914
	in.	18 x 28	18 x 36

REVISIONS

Sections	Description of Change
Options/Accessories	Catalog numbers revised for: Economizers Single Enthalpy



Visit us at www.lennox.com

For the latest technical information, www.lennoxcommercial.com

Contact us at 1-800-4-LENNOX

NOTE - Due to Lennox' ongoing commitment to quality, Specifications, Ratings and Dimensions subject to change without notice and without incurring liability. Improper installation, adjustment, alteration, service or maintenance can cause property damage or personal injury. Installation and service must be performed by a qualified installer and servicing agency.

©2021 Lennox Industries, Inc.