



ZGA

Raider® Rooftop Units

50 Hz

COMMERCIAL
PRODUCT SPECIFICATIONS

Bulletin No. 490161
March 2021
Supersedes March 2019



RAIDER®
Value Without Compromise®



26 to 44 kW (7.5 to 12.5 Tons)
Net Cooling Capacity – 22.5 to 34.5 kW (76 800 to 117 800 Btuh)
Gas Input Heat Capacity – 24.8 to 61.5 kW (84 000 to 210 000 Btuh)

MODEL NUMBER IDENTIFICATION

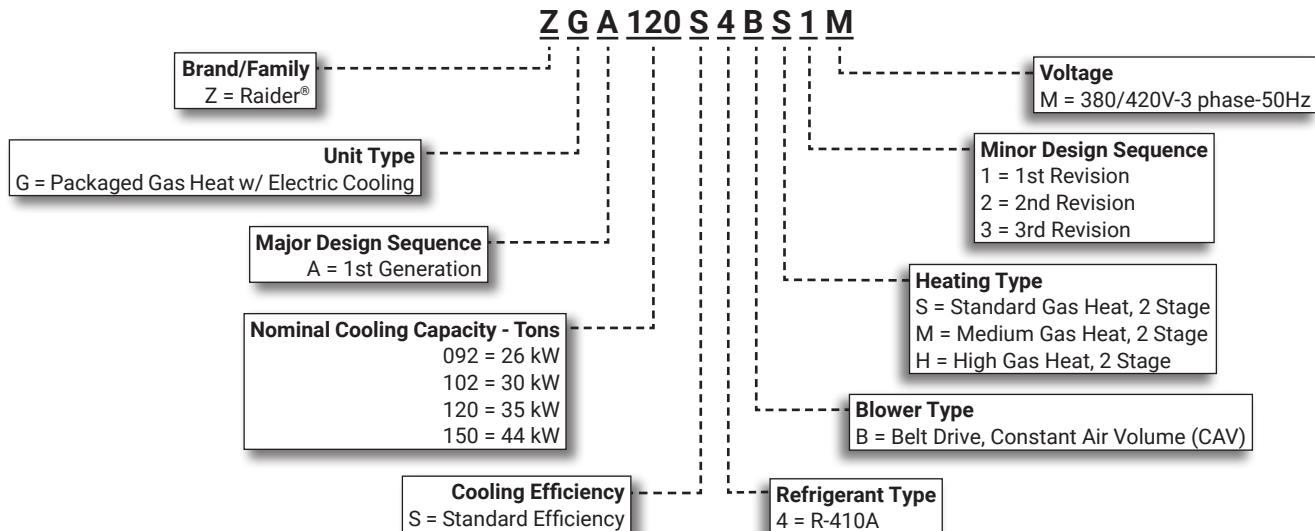

FEATURE HIGHLIGHTS

Raider® rooftop units from Lennox Commercial are the new standard for cost efficient reliable, efficient rooftop units built for long-lasting performance that can significantly improve indoor environments.

1. Aluminized Steel Heat Exchanger
2. Scroll Compressors
3. Lennox' Environ™ Coil System
4. Outdoor Coil Fans
5. Heavy Gauge Steel Cabinet
6. Supply Air Blower

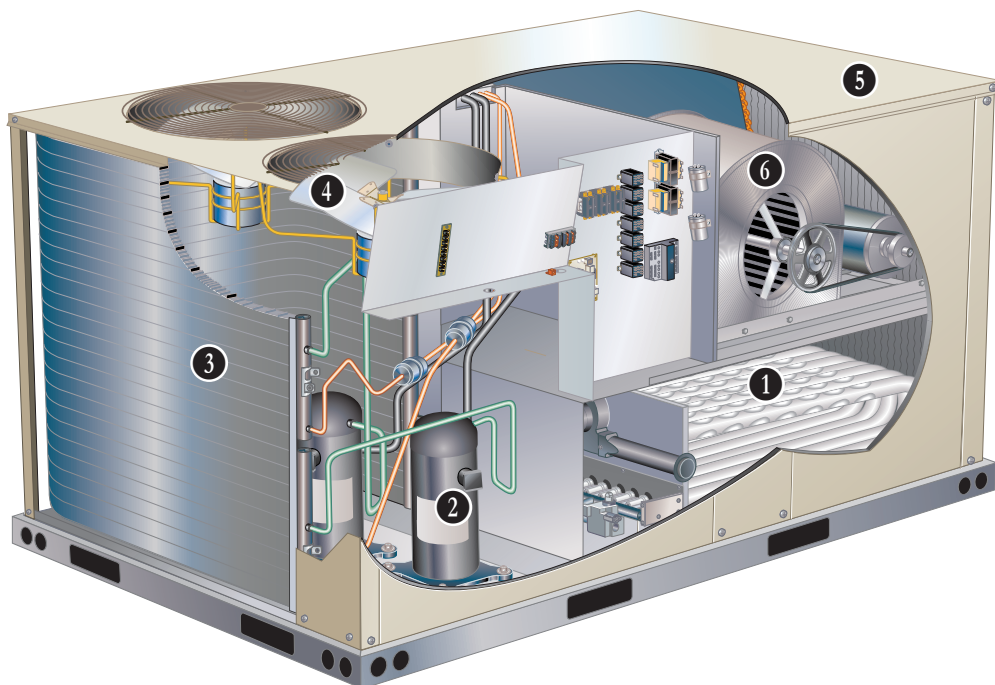

CONTENTS

Accessory Dimensions	28
Approvals	3
Blower Data	18
Dimensions	27
Electrical Data	24
Features And Benefits	3
Model Number Identification.	1
Optional Conventional Temperature Control Systems	8
Options / Accessories	9
Outdoor Sound Data	25
Ratings.	14
Specifications	12
Specifications - Gas Heat	13
Unit Clearances	25
Weight Data	26

APPROVALS

PERFORMANCE / QUALITY

- Components bonded for grounding to meet safety standards for servicing required by Underwriters Laboratories (UL) and the International Electrotechnical Commission (IEC)
- Cooling performance is rated at test conditions included in Air- Conditioning, Heating and Refrigeration Institute (AHRI) Standard 340/360-2007 while operating at rated voltage and air volumes
- International Organization for Standardization (ISO) 9001 Registered Manufacturing Quality System

FEATURES AND BENEFITS

HEATING SYSTEM

- Aluminized steel inshot burners
- Direct spark ignition
- Electronic flame sensor
- Combustion air inducer
- Redundant automatic dual stage gas valve with manual shut-off

① Heat Exchanger

- Tubular construction, aluminized steel
- Life-cycle tested

NOTE - Optional Stainless Steel Heat Exchanger is required if mixed air temperature is below 7°C.

Electronic Pilot Ignition

- Electronic spark igniter provides positive direct ignition
Electronic spark igniter provides positive direct ignition of burners on each operating cycle
- Permits main gas valve to stay open only when the burners are proven to be lit
- If loss of flame occurs, gas valve closes, shutting off the gas to the burners
- LED indicates status and aids in troubleshooting
- Watchguard circuit on module automatically resets ignition controls after one hour of continuous thermostat demand after unit lockout, eliminating nuisance service calls
- Factory installed in the gas heating compartment

Limit Control

- Redundant limit controls with fixed temperature setting
- Protects heat exchanger and other components from overheating

Safety Switches

- Flame roll-out switch
- Flame sensor
- Combustion air inducer proving switch
- Protects system operation

Required Selections

Gas Input Choice - Order one:

- Standard Gas Heat, 2 Stage (24.8/33.4 kW)
- Medium Gas Heat, 2 Stage (34.3/46.7 kW)
- High Gas Heat, 2 Stage (45.7/61.5 kW)

Options/Accessories

Factory Installed

Stainless Steel Heat Exchanger

- Required if mixed air temperature is below 7°C

Field Installed

LPG/Propane Kits

- Conversion kit to field change over units from Natural Gas to LPG/Propane

Combustion Air Intake Extensions

- Recommended for use with existing flue extension kits in areas where high snow areas can block intake air

Vertical Vent Extension Kit

- Use to exhaust flue gases vertically above unit
- Required when unit vent is too close to fresh air intakes per building codes
- Also prevents ice formation on intake louvers
- Kit contains vent transition, vent tee, drain cap and installation hardware

NOTE - Straight vent pipes (102 mm B-Vent) and caps are not furnished and must be field supplied. Refer to kit installation instructions for additional information.

COOLING SYSTEM

- Designed to maximize sensible and latent cooling performance at design conditions
- System can operate from 4.4°C (10°C for 150 models) to 52°C without any additional controls

R-410A Refrigerant

- Non-chlorine based
- Ozone friendly

② Scroll Compressors

- Scroll compressors on all models for high performance reliability
- Resiliently mounted on rubber grommets for quiet operation

Refrigerant Metering Orifice

- Accurately meters refrigerant in system
- Refrigerant control is accomplished by exact sizing of refrigerant metering orifice

FEATURES AND BENEFITS

COOLING SYSTEM (continued)

Filter/Driers

- High capacity filter/drier protects the system from dirt and moisture

High Pressure Switches

- Protects the compressor from overload conditions such as dirty condenser coils, blocked refrigerant flow, or loss of outdoor fan operation

3 Lennox' Environ™ Coil System

- Lightweight, all aluminum brazed fin construction
- Constructed of three components:
 - A flat extrusion tube
 - Fins in-between the flat extrusion tube
 - Two refrigerant manifolds

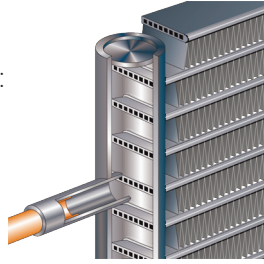

Environ™ Coil System Features:

- Improved heat transfer performance due to high primary surface area (flat tubes) versus secondary surface (fins)
- Smaller internal volume (reduced refrigerant charge)
- High durability
- All aluminum construction
- Fewer brazed joints
- Compact design
- Reduced unit weight
- Easy maintenance/cleaning
- Face split design
- Mounting brackets with rubber inserts

Evaporator Coil

- Copper tube construction
- Enhanced rippled-edge aluminum fins
- Flared shoulder tubing connections
- Silver soldered construction
- Cross row circuiting with rifled tubing

Condensate Drain Pan

- Plastic pan, sloped to meet drainage requirements per ASHRAE 62.1
- Side drain connections

Outdoor Coil Fan Motors

- Thermal overload protected
- Totally enclosed
- Permanently lubricated ball bearings
- Shaft up
- Wire basket mount

4 Outdoor Coil Fans

- Polyvinyl Chloride (PVC) coated fan guard furnished

Required Selections

Cooling Capacity

- Specify nominal cooling capacity

Options/Accessories

Field Installed

Condensate Drain Trap

- Available in copper or PVC

Drain Pan Overflow Switch

- Monitors condensate level in drain pan
- Shuts down unit if drain becomes clogged

Low Ambient Kit (Includes Compressor Crankcase Heater)

- Cycles the outdoor fans while allowing compressor operation in the cooling cycle
- Intermittent fan operation allows the system to operate without icing the evaporator coil and losing capacity
- Designed for use in ambient temperatures no lower than -18°C
- Controls the compressor crankcase heaters

NOTE - Compressor crankcase heater is furnished with kit. Protects against refrigerant migration that can occur during low ambient operation.

CONTROLS

Unit Control

- All control voltage is provided via a 24V (secondary) transformer with built-in circuit breaker protection
- **Heat/Cool Staging** - Capable of up to 2 heat / 2 cool staging with a third party DDC control system or thermostat
- **Low Voltage Terminal Block** - Provides screw terminal connections for thermostat or controller wiring
- **Night Setback Mode** - Saves energy by closing outdoor air dampers and operating supply fan on thermostat demand only

Options / Accessories

Smoke Detectors

NOTE - Smoke detectors are not available and must be field provided by installer.

Commercial Control Systems

Thermostats

- Control system and thermostat options, see page 26.

CABINET

5 Construction

- Heavy-gauge steel panels
- Full perimeter heavy-gauge galvanized steel base rail
- Base rails have rigging holes
- Three sides of the base rail have forklift slots
- Raised edges around duct and power entry openings in the bottom of the unit for water protection

Airflow Choice

- Units are shipped in downflow (vertical) return air flow configuration

NOTE - Units can be field converted to horizontal airflow.

FEATURES AND BENEFITS

CABINET (continued)

Duct Flanges

- Provided for horizontal duct attachment

Power Entry

- Electrical lines can be brought through the unit base or through horizontal access knock-outs

NOTE - Optional Bottom Power Entry Kit is available.

Exterior Panels

- Constructed of heavy-gauge, galvanized steel
- Two-layer enamel paint finish

Insulation

- Fully insulated with non-hygroscopic fiberglass insulation (conditioned areas)

Access Panels

- Filter section
- Blower/heating section
- Compressor/controls section
- Recessed handles for easy service access

Options/Accessories

Factory Installed

Corrosion Protection

- Completely flexible immersed coating
- Electrodeposited dry film process (AST ElectroFin E-Coat)
- Meets Mil Spec MIL-P-53084, ASTM B117 Standard Method Salt Spray Testing
- Indoor Corrosion Protection:
 - Coated coil
- Outdoor Corrosion Protection:
 - Coated coil

Field Installed

Combination Coil/Hail Guards

- Heavy gauge steel frame
- Painted to match cabinet
- Expanded metal mesh protects outdoor coil

BLOWER

- 6 A wide selection of supply air blower options are available to meet a variety of airflow requirements.

Constant Air Volume Blower (CAV)

- Supply air blower provides a constant volume of air

Motor

- Overload protected
- Ball bearings
- Belt drive motors are offered on all models and are available in several different sizes to maximize air performance

Supply Air Blower

- Forward curved blades
- Double inlet
- Blower wheel statically and dynamically balanced
- Ball bearings
- Adjustable pulley (allows speed change)

Required Selections

- Order blower motor horsepower and drive kit number required when base unit is ordered
- See Drive Kit Specifications Table

ELECTRICAL

Marked & Color-Coded Wiring

- All electrical wiring is color-coded and marked to identify which components it is connecting

Electrical Plugs

- Positive connection electrical plugs are used to connect common accessories or maintenance parts for easy removal or installation

Required Selections

Voltage Choice

- Specify when ordering base unit

Field Installed

Bottom Power Entry Kit

- Reduces the number of penetrations in the roof
- Includes bulkhead connectors to provide power and control wiring routing through the roof curb

INDOOR AIR QUALITY

Air Filters

- Disposable 51 mm filters furnished as standard

Options/Accessories

Field Installed

Healthy Climate® High Efficiency Air Filters

- Disposable MERV 8 or MERV 13 (Minimum Efficiency Reporting Value based on ASHRAE 52.2) efficiency 51 mm pleated filters

Replacement Filter Media Kit With Frame

- Replaces existing pleated filter media
- Includes washable metal mesh screen and metal frame with clip for holding replaceable non-pleated filter

Indoor Air Quality (CO₂) Sensors

- Monitors CO₂ levels, reports to the economizer to adjust dampers as needed

OPTIONS / ACCESSORIES

ECONOMIZER

Factory or Field Installed

NOTE - Downflow Economizer is factory or field installed.
Horizontal Economizer is field installed only.

Economizer

(Standard and High Performance Common Features)

- Downflow or Horizontal with Outdoor Air Hood and Barometric Relief Dampers with Exhaust Hood
- Barometric Relief Dampers allow relief of excess air
- Aluminum blade dampers prevent blow back and outdoor air infiltration during off cycle
- Bird screen furnished

NOTE - Outdoor Air and Barometric Relief Exhaust Hoods are included when economizer is factory installed and are furnished with economizer when ordered for field installation.

- Occupied/Unoccupied mode with field furnished setback thermostat
- Demand Control Ventilation (DCV) ready using optional CO₂ sensors
- Single temperature control is furnished with Economizer
- Outdoor air temperature sensor enables Economizer if the outdoor temperature is less than the setpoint of the control

Standard Economizer Features

- Gear-driven action
- Return air and outdoor air dampers
- Plug-in connections to unit
- Nylon bearings
- Neoprene seals
- 24-volt
- Fully-modulating spring return motor

Standard Economizer Control Module

The Standard Economizer Control Module can be adjusted to operate based on outdoor air temperatures.

Economizer Controls:

- Damper Minimum Position - Can be set lower than traditional minimum air requirements resulting in cost savings
- IAQ Sensor - Signals dampers to modulate and maintain 13°C when CO₂ is higher than the CO₂ setpoint
- Demand Control Ventilation (DCV) LED - A steady green Demand Control Ventilation LED indicates the IAQ reading is higher than setpoint and requires more fresh air
- Free Cool LED - A steady green LED indicates outdoor air is suitable for free cooling
- Free Cooling runs when outdoor air temperature is lower than the set temperature on the economizer control

NOTE: The Free Cooling default setting for outdoor air temperature sensor is 13°C.



High Performance Economizer Features

- Parallel gear-driven action
- High torque 24-volt fully-modulating spring return damper motor
- Return air and outdoor air dampers
- Plug-in connections to unit
- Stainless steel bearings
- Enhanced thermoplastic vulcanizate (TPV) blade edge seals
- Flexible stainless steel jamb seals to minimize air leakage

High Performance Economizer Control Module

- Module provides inputs and outputs to control economizer based on parameter settings
- Module automatically detects sensors by polling to determine which sensors are installed in system
- Module displays any alarm messages (fault detection and diagnostics) as an aid in troubleshooting
- Non-volatile memory retains parameter settings in case of power failure
- Keypad with four navigation buttons and LCD screen is furnished for setting economizer parameters
 - Menu Up/Exit (↑) button returns to the main menu.
 - Arrow Up (▲) button moves to the previous or next parameter within the selected menu.
 - Arrow Down (▼) button moves to the next parameter within the selected menu.
 - Select (enter) (↵) button confirms parameter selection.



Main Menu Structure:

- STATUS (economizer and system operation status)
- SETPOINTS (settings for various setpoint parameters)
- SYSTEM SETUP (settings/information about the system)
- ADVANCED SETUP (freeze protection, CO₂ settings, stage 3 delay and additional calibration settings)
- CHECKOUT (damper positions)
- ALARMS (output signal that can be configured for remote alarm monitoring)

NOTE - Refer to Installation Instructions for complete setup information and menu parameters available

Field Installed

Single Enthalpy Temperature Control

- Outdoor air enthalpy sensor enables Economizer if the outdoor enthalpy is less than the setpoint of the control

Differential Enthalpy Control

- Order two Single Enthalpy Controls
- One is field installed in the return air section, the other in the outdoor air section
- Allows the Economizer control board to select between outdoor air or return air, whichever has lower enthalpy

OPTIONS / ACCESSORIES

EXHAUST

Field Installed

Horizontal Low Profile Barometric Relief Dampers

- For use when unit is configured for horizontal applications in a reduced space requiring an Economizer
- Allows relief of excess air
- Aluminum blade dampers prevent blow back and outdoor air infiltration during off cycle
- Field installed in return air duct
- Exhaust hood with bird screen furnished

Power Exhaust Fan

- Installs internal to unit for downflow applications only with economizer option
- Provides exhaust air pressure relief
- Interlocked to run when supply air blower is operating
- Fan runs when outdoor air dampers are 50% open (adjustable)
- Motor is overload protected.
- Fan is 508 mm diameter
- 5 blades (K1PWRE10B)
- 0.25 kW motor

NOTE - Requires Economizer with Outdoor Air Hood and Barometric Relief Dampers.

OUTDOOR AIR

Field Installed

Outdoor Air Damper

- Downflow or Horizontal
- Linked mechanical dampers
- 0 to 25% (fixed) outdoor air adjustable
- Installs in unit
- Includes outdoor air hood
- Automatic model features fully modulating spring return damper motor with plug-in connection
- Manual model features a slide damper

NOTE - Maximum mixed air temperature in cooling mode: 38°C.

ROOF CURBS

Field Installed

Hybrid Roof Curbs, Downflow

- Nailer strip furnished; mates to unit
- US National Roofing Contractors approved
- Shipped knocked down
- Interlocking tabs fasten corners together; no tools required
- Can also be fastened together with furnished hardware
- Available in 203, 356, 457, and 610 mm heights

CEILING DIFFUSERS

Field Installed

(Flush or Step-Down)

- White powder coat finish on diffuser face and grilles
- Insulated UL listed duct liner
- Diffuser box has collars for duct connection
- Step-down diffusers have double deflection blades
- Flush diffusers have fixed blades
- Provisions for suspending
- Internally sealed to prevent recirculation
- Removable return air grille
- Adapts to T-bar ceiling grids or plaster ceilings

Transitions (Supply and Return)

NOTE - Ceiling Diffuser Transitions are not furnished and must be field fabricated.

OPTIONAL CONVENTIONAL TEMPERATURE CONTROL SYSTEMS

ComfortSense® 7500 Commercial 7-Day Programmable Thermostat



- Four-Stage Heating / Two-Stage Cooling
- Universal Multi-Stage
- Intuitive Touchscreen Interface
- Automatic Changeover between Heating and Cooling
- Full Seven-Day Programming
- Four Time Periods Per Day
- Temperature and Humidity Control
- One-Touch Away Mode
- Holiday Scheduling
- Smooth Setback Recovery (SSR)
- Performance Reports
- Notifications/Reminders
- Economizer Relay Control
- Backlit Display
- Wallplate Furnished
- FDD, ASHRAE and IECC Compliant

ComfortSense® 3000 Commercial 5-2 Day Programmable Thermostat

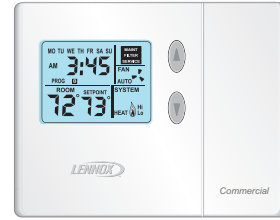

- Two-Stage Heating / Two-Stage Cooling
- Conventional Systems
- Intuitive Interface
- 5-2 Day Programming
- Program Hold
- Remote Indoor Temperature Sensing
- Smooth Setback Recovery (SSR)
- Economizer Relay Control
- Maintenance/Filter/Service Reminders
- Backlit Display
- Wallplate Furnished
- Simple Up and Down Temperature Control

Bacnet Compatible Thermostat With Reheat Function



- 7-Day Programmable
- BTL listed MS/TP ensures compatibility with any BACnet system
- Built-in control programs for conventional and heat pump applications
- Conventional systems up to 3-stage heat and 3-stage cool
- Heat pumps with 1 or 2 compressors and up to 2-stage auxiliary heat
- On-board temperature and humidity sensor
- Multiple configurable inputs and outputs enable advanced control strategies
- Set-up Wizard enables rapid system configuration
- No special tools required for installation or commissioning
- Seven-day (2, 4 or 6 event) occupancy scheduling per day
- Backlit 5-inch LCD touchscreen

Description	Model No.	Catalog No.
ComfortSense® 7500 7-Day Programmable	C0STAT06FF2L	17G74
Universal thermostat locking guard (clear)	C0MISC15AE1-	39P21
Temperature Sensors	¹ Remote non-adjustable wall-mount 20k	47W36
	¹ Remote non-adjustable wall-mount 10k	47W37
	Remote non-adjustable discharge air (duct mount)	19L22
	Outdoor temperature sensor	X2658
¹ Remote wall-mount sensors can be applied in any of the following combinations: One Sensor - (1) 47W36, Two Sensors - (2) 47W37, Three Sensors - (2) 47W36 and (1) 47W37 Four Sensors - (4) 47W36, Five Sensors - (3) 47W36 and (2) 47W37		
ComfortSense® 3000 5-2 Day Programmable	C0STAT05FF1L	11Y05
Thermostat wall mounting plate	C0MISC17AE1-	X2659
Temperature Sensor	Remote non-adjustable wall mount 10k averaging	47W37
BACnet Controls	7-Day BACnet Thermostat	Y8241
	BACnet Module (factory or field)	16X71
² BACnet Room Sensors	With Display	97W23
	Without Display	97W24

² Only compatible with BACnet Module (16X71).

OPTIONS / ACCESSORIES

Item Description	Model Number	Catalog Number	Unit Model No			
			092	102	120	150
COOLING SYSTEM						
Condensate Drain Trap	Polyvinyl Chloride (PVC) - C1TRAP20AD2	22H54	X	X	X	X
	Copper - C1TRAP10AD2	76W27	X	X	X	X
Corrosion Protection		Factory	O	O	O	O
Drain Pan Overflow Switch	Z1SNSR90A1	99W59	X	X	X	X
Low Ambient Kit (Includes Compressor Crankcase Heater)	380/420V-3ph - Z1LOAM02B-1G	10Z36	X	X		
	380/420V-3ph - Z1LOAM12B-1G	10Z51			X	X
Refrigerant Type		R-410A	O	O	O	O
HEATING SYSTEM						
Combustion Air Intake Extensions	T1EXTN10AN1	19W51	X	X	X	X
Gas Heat Input	33.4 kW	Factory	O	O	O	O
	46.7 kW	Factory	O	O	O	O
	61.5 kW	Factory	O	O	O	O
LPG/Propane Conversion Kits	Standard Heat - C1PROP23BS1	14N22	X	X	X	X
	Medium Heat - Z1PROP24RS1	14N27	X	X	X	X
	High Heat - C1PROP21BS1	14N25	X	X	X	X
Stainless Steel Heat Exchanger		Factory	O	O	O	O
Vertical Vent Extension Kit	C1EXTN20FF1	31W62	X	X	X	X
BLOWER - SUPPLY AIR						
Blower Motors	Belt Drive - 1.5 kW	Factory	O	O	O	O
	Belt Drive - 2.2 kW	Factory	O	O	O	O
	Belt Drive - 3.7 kW	Factory	O	O	O	O
Drive Kits See Blower Data Tables for selection	Kit #1 490-740 rev/min	Factory	O	O	O	O
	Kit #2 665-920 rev/min	Factory	O	O	O	O
	Kit #3 660-995 rev/min	Factory	O	O	O	O
	Kit #7 610-810 rev/min	Factory	O	O	O	O
	Kit #8 780-1000 rev/min	Factory	O	O	O	O
	Kit #9 845-1085 rev/min	Factory	O	O	O	O
	Kit #10 750-945 rev/min	Factory	O	O	O	O
	Kit #11 865-1095 rev/min	Factory	O	O	O	O
	Kit #12 940-1190 rev/min	Factory	O	O	O	O
CABINET						
Combination Coil/Hail Guards	Z1GARD52B-1	96W15	X	X	X	X

NOTE - Catalog and model numbers shown are for ordering field installed accessories.

OX - Configure To Order (Factory Installed) or Field Installed

O = Configure To Order (Factory Installed)

X = Field Installed

OPTIONS / ACCESSORIES

Item Description	Model Number	Catalog Number	Unit Model No			
			092	102	120	150
ELECTRICAL						
Voltage 50 hz with neutral	380/420V - 3 phase	Factory	O	O	O	O
Bottom Power Entry Kit	Z1PEKT01B-1	11H66	X	X	X	X
INDOOR AIR QUALITY						
Air Filters						
Healthy Climate® High Efficiency Air Filters	MERV 8 - Z1FLTR15B-1	11H62	X	X	X	X
508 x 610 x 51 mm, Order 4 per unit	MERV 13 - Z1FLTR40B-1	11H63	X	X	X	X
Replacement Media Filter With Metal Mesh Frame (includes non-pleated filter media)	Z1FLTR30B-1-	Y3063	X	X	X	X
Indoor Air Quality (CO₂) Sensors						
Sensor - Wall-mount, off-white plastic cover with LCD display	C0SNSR50AE1L	77N39	X	X	X	X
Sensor - Wall-mount, black plastic case, no display, rated for plenum mounting	C0MISC19AE1	87N54	X	X	X	X
CO ₂ Sensor Duct Mounting Kit - for downflow applications	C0MISC19AE1-	85L43	X	X	X	X
Aspiration Box - for duct mounting non-plenum rated CO ₂ sensors (87N53 or 77N39)	C0MISC16AE1-	90N43	X	X	X	X
ECONOMIZER						
Standard Economizer						
Standard Downflow Economizer with Single Temperature Control - With Barometric Relief Dampers and Air Hoods	Z1ECON30B-1	10Z29	OX	OX	OX	OX
Standard Horizontal Economizer with Single Temperature Control - With Barometric Relief Dampers and Air Hoods	Z1ECON16B-1	11G98	X	X	X	X
Standard Economizer Controls						
Single Enthalpy Control	C1SNSR64FF1	53W64	X	X	X	X
Differential Enthalpy Control (order 2)	C1SNSR64FF1	53W64	X	X	X	X
High Performance Economizer						
High Performance Downflow Economizer with Single Temperature Control - With Barometric Relief Dampers and Air Hoods	Z1ECON32B-3	20V25	OX	OX	OX	OX
High Horizontal Economizer with Single Temperature Control - With Barometric Relief Dampers and Air Hoods	Z1ECON33B-3	20V26	X	X	X	X
High Performance Economizer Controls						
Single Enthalpy Control	C1SNSR61FF1	11G21	X	X	X	X
Differential Enthalpy Control (order 2)	C1SNSR61FF1	11G21	X	X	X	X
Horizontal Low Profile Barometric Relief Dampers With Exhaust Hood						
Horizontal Low Profile Barometric Relief Dampers With Exhaust Hood	LAGEDH03/15	53K04	X	X	X	X
OUTDOOR AIR						
Outdoor Air Dampers						
Motorized Dampers with outdoor air hood	Z1DAMP20B-2	14G36	X	X	X	X
Manual Dampers with outdoor air hood	Z1DAMP10B-2	14G37	X	X	X	X

NOTE - Catalog and model numbers shown are for ordering field installed accessories.

OX - Configure To Order (Factory Installed) or Field Installed

O = Configure To Order (Factory Installed)

X = Field Installed

OPTIONS / ACCESSORIES

Item Description	Model Number	Catalog Number	Unit Model No			
			092	102	120	150
POWER EXHAUST						
Standard Static (Downflow)	380/420V-3ph - Z1PWRE10B-1G	10Z71	X	X	X	X
Standard Static (Horizontal)	380/420V-3ph - Z1PWRE15A-1G	28E01	X	X	X	X
ROOF CURBS						
Hybrid Roof Curbs, Downflow						
203 mm height	Z1CURB40B-1	10Z25	X	X	X	X
356 mm height	Z1CURB41B-1	10Z26	X	X	X	X
457 mm height	Z1CURB42B-1	10Z27	X	X	X	X
610 mm height	Z1CURB43B-1	10Z28	X	X	X	X
CEILING DIFFUSERS						
Step-Down - Order one	RTD11-95S	13K61	X			
	RTD11-135S	13K62		X	X	
	RTD11-185S	13K63				X
Flush - Order one	FD11-95S	13K56	X			
	FD11-135S	13K57		X	X	
	FD11-185S	13K58				X

NOTE - Ceiling Diffuser Transitions are not furnished and must be field fabricated.

NOTE - Catalog and model numbers shown are for ordering field installed accessories.

OX - Configure To Order (Factory Installed) or Field Installed

O = Configure To Order (Factory Installed)

X = Field Installed

SPECIFICATIONS

General Data		Nominal kW (Tonnage)	26 (7.5)	30 (8.5)	35 (10)	44 (12.5)
	Model Number		ZGA092S4B	ZGA102S4B	ZGA120S4B	ZGA150S4B
	Efficiency Type		Standard	Standard	Standard	Standard
	Blower Type		Constant Air Volume (CAV)	Constant Air Volume (CAV)	Constant Air Volume (CAV)	Constant Air Volume (CAV)
Cooling Performance	Gross Cooling Capacity - kW (Btuh)		23.2 (79 000)	25.9 (88 300)	30.3 (103 500)	36.0 (122 900)
	¹ Net Cooling Capacity - kW (Btuh)		22.5 (76 800)	25.1 (85 700)	29.3 (100 000)	34.5 (117 800)
	AHRI Rated Air Flow - L/s (cfm)		1320 (2800)	1535 (3250)	1795 (3800)	2075 (4400)
	Total Unit Power - kW		6.8	7.6	9.0	10.9
	¹ EER (Btuh/Watt)		11.3	11.2	11.1	10.8
	¹ IEER (Btuh/Watt)		11.2	11.2	11.2	10.8
	Refrigerant Type		R-410A	R-410A	R-410A	R-410A
	Refrigerant Charge Furnished	Circuit 1		2.0 kg (4 lbs. 7 oz.)	2.2 kg (4 lbs. 13 oz.)	2.3 kg (5 lbs 0 oz.)
	Circuit 2		1.4 kg (3 lbs. 1 oz.)	2.1 kg (4 lbs. 10 oz.)	2.4 kg (5 lbs 4 oz.)	3.1 kg (6 lbs 12 oz.)
Gas Heating Options Available - See page 13			Standard (2 stage), Medium (2 Stage), High (2 Stage)			
Compressor Type (number)			Scroll (2)			
Outdoor Coils	Net face area (total) - m ² (sq. ft.)		1.94 (20.9)	1.94 (20.9)	2.6 (28.0)	2.6 (28.0)
	Number of rows		1	1	1	1
	Fins per m (in.)		906 (23)	906 (23)	906 (23)	787 (20)
Outdoor Coil Fans	Motor - (No.) W (hp)		(2) 249 (1/3)	(2) 249 (1/3)	(2) 249 (1/3)	(2) 373 (1/2)
	Motor rev/min (rpm)		896	896	896	896
	Total Motor watts		617	617	583	792
	Diameter - (No.) mm (in.)		(2) 610 (24)	(2) 610 (24)	(2) 610 (24)	(2) 610 (24)
	Number of blades		3	3	3	3
	Total Air volume - L/s (cfm)		3460 (7333)	3460 (7333)	3540 (7500)	3775 (8000)
Indoor Coils	Net face area (total) - m ² (sq. ft.)		1.19 (12.8)	1.19 (12.8)	1.26 (13.54)	1.26 (13.54)
	Tube diameter - mm (in.)		9.5 (3/8)	9.5 (3/8)	9.5 (3/8)	9.5 (3/8)
	Number of rows		2	3	3	4
	Fins per mm (in.)		551 (14)	551 (14)	551 (14)	551 (14)
	Drain connection - Number and size		(2) 1 in. NPT coupling			
	Expansion device type		Refrigerant Metering Orifice (RFC)			
² Indoor Blower and Drive Selection	Nominal motor output		1.5 kW, 2.2 kW, 3.7 kW (2 hp, 3 hp, 5 hp)			
	Maximum usable motor output		1.7 kW, 2.6 kW, 4.3 kW (2.3 hp, 3.45 hp, 5.75 hp)			
	Motor - Drive kit number		1.5 kW (2 hp) Kit 1 490-740 rev/min Kit 2 665-920 rev/min Kit 3 660-995 rev/min 2.2 kW (3 hp) Kit 7 610-810 rev/min Kit 8 780-1000 rev/min Kit 9 845-1085 rev/min 3.7 kW (5 hp) Kit 10 750-945 rev/min Kit 11 865-1095 rev/min Kit 12 940-1190 rev/min			
	Blower wheel nominal diameter x width - mm (in.)		(1) 381 x 381 (15 X 15)			
Filters	Type of filter		Disposable			
	Number and size - mm (in.)		(4) 508 x 610 x 51 (20 x 24 x 2)			
Electrical characteristics			380/420V - 50 hertz - 3 phase with neutral			

NOTE - Net capacity includes evaporator blower motor heat deduction. Gross capacity does not include evaporator blower motor heat deduction.

¹ Tested at conditions included in AHRI Standard 340/360; 35°C (95°F) outdoor air temperature and 27°C (80°F) dry bulb /19°C (67°F) wet bulb entering evaporator air; minimum external duct static pressure while operating at rated voltage and air volumes.

² Using total air volume and system static pressure requirements determine from blower performance tables rev/min and motor output required. Maximum usable output of motors furnished are shown. If motors of comparable output are used, be sure to keep within the service factor limitations outlined on the motor nameplate.

SPECIFICATIONS - GAS HEAT

			Standard	Medium	High
			2	2	2
Gas Heating Performance	Input - kW (Btuh)	First Stage	24.8 (84 500)	34.3 (117 000)	45.7 (156 000)
		Second Stage	33.4 (114 000)	46.7 (159 500)	61.5 (210 000)
	Output - kW (Btuh)	Second Stage	26.7 (91 200)	36.9 (126 000)	49.2 (168 000)
Temperature Rise Range - °C (°F)			8 - 25 (15 - 45)	17 - 33 (30-60)	22 - 39 (40 - 70)
Thermal Efficiency			81%	81%	81%
Gas Supply Connections			3/4 in. NPT	3/4 in. NPT	3/4 in. NPT
Recommended Gas Supply Pressure - kPa (in. w.g.)	Natural		1.7 (7)	1.7 (7)	1.7 (7)
	LPG/Propane		2.7 (11)	2.7 (11)	2.7 (11)

HIGH ALTITUDE DERATE

Units may be installed at altitudes up to 610 m (2000 feet) above sea level without any modification.

At altitudes above 610 m (2000 feet), units must be derated to match gas manifold pressures shown in table below.

At altitudes above 1371.6 (4500 feet) unit must be derated 2% for each 305 m (1000 feet) above sea level.

NOTE – This is the only permissible derate for these units.

Gas Heat Type	Altitude	Gas Manifold Pressure		Input Rate Natural Gas or LPG/Propane	
		Natural Gas	LPG/Propane Gas	First Stage	Second Stage
	m (ft.)	kPa (In. w.g.)	kPa (In. w.g.)	kW (Btuh)	kW (Btuh)
Standard	610-1372 (2001-4500)	0.62 (2.5)	1.82 (7.3)	24.8 (84 500)	31.7 (108 000)
Medium	610-1372 (2001-4500)	0.62 (2.5)	1.82 (7.3)	34.3 (117 000)	43.7 (149 000)
High	610-1372 (2001-4500)	0.62 (2.5)	1.82 (7.3)	45.7 (156 000)	58 (198 000)

RATINGS

NOTE – For Temperatures and Capacities not shown in tables, see bulletin – Cooling Unit Rating Table Correction Factor Data in Miscellaneous Engineering Data section.

26 KW STANDARD EFFICIENCY ZGA092S4B (1ST STAGE) - CONSTANT AIR VOLUME

Entering Wet Bulb Temperature	Total Air Volume	Outdoor Air Temperature Entering Outdoor Coil																			
		18.3°C					23.9°C					29.4°C					35°C				
		Total Cool Cap.	Comp. Motor Input	Sensible To Total Ratio (S/T)			Total Cool Cap.	Comp. Motor Input	Sensible To Total Ratio (S/T)			Total Cool Cap.	Comp. Motor Input	Sensible To Total Ratio (S/T)			Total Cool Cap.	Comp. Motor Input	Sensible To Total Ratio (S/T)		
				Dry Bulb					Dry Bulb					Dry Bulb					Dry Bulb		
L/s	kW	kW	24°C	27°C	29°C	kW	kW	24°C	27°C	29°C	kW	kW	24°C	27°C	29°C	kW	kW	24°C	27°C	29°C	
17.2°C	1133	16.6	2.27	0.68	0.81	0.95	15.9	2.53	0.69	0.83	0.97	15.1	2.83	0.70	0.84	0.99	14.2	3.19	0.71	0.87	1.00
	1416	17.5	2.29	0.72	0.87	1.00	16.7	2.55	0.73	0.89	1.00	15.9	2.85	0.74	0.91	1.00	14.9	3.21	0.76	0.94	1.00
	1699	18.2	2.30	0.76	0.93	1.00	17.4	2.56	0.77	0.95	1.00	16.5	2.86	0.78	0.98	1.00	15.5	3.22	0.80	1.00	1.00
19.4°C	1133	17.4	2.28	0.55	0.66	0.78	16.6	2.55	0.55	0.67	0.79	15.8	2.85	0.55	0.68	0.81	14.9	3.20	0.56	0.69	0.83
	1416	18.4	2.30	0.57	0.70	0.84	17.5	2.56	0.57	0.71	0.86	16.6	2.87	0.58	0.72	0.88	15.6	3.22	0.58	0.73	0.90
	1699	19.0	2.32	0.59	0.74	0.90	18.1	2.58	0.59	0.75	0.92	17.1	2.88	0.60	0.76	0.94	16.1	3.23	0.61	0.78	0.97
21.7°C	1133	18.2	2.30	0.42	0.53	0.64	17.4	2.56	0.42	0.54	0.65	16.5	2.86	0.42	0.54	0.66	15.6	3.22	0.42	0.55	0.67
	1416	19.2	2.32	0.43	0.56	0.68	18.3	2.58	0.43	0.56	0.69	17.3	2.88	0.42	0.57	0.70	16.3	3.23	0.42	0.57	0.72
	1699	19.9	2.34	0.45	0.58	0.71	19.0	2.59	0.44	0.59	0.73	17.9	2.89	0.45	0.59	0.74	16.8	3.25	0.45	0.60	0.76

26 KW STANDARD EFFICIENCY ZGA092S4B (2ND STAGE) - CONSTANT AIR VOLUME

Entering Wet Bulb Temperature	Total Air Volume	Outdoor Air Temperature Entering Outdoor Coil																			
		26.7°C					35°C					43.3°C					51.7°C				
		Total Cool Cap.	Comp. Motor Input	Sensible To Total Ratio (S/T)			Total Cool Cap.	Comp. Motor Input	Sensible To Total Ratio (S/T)			Total Cool Cap.	Comp. Motor Input	Sensible To Total Ratio (S/T)			Total Cool Cap.	Comp. Motor Input	Sensible To Total Ratio (S/T)		
				Dry Bulb					Dry Bulb					Dry Bulb					Dry Bulb		
L/s	kW	kW	24°C	27°C	29°C	kW	kW	24°C	27°C	29°C	kW	kW	24°C	27°C	29°C	kW	kW	24°C	27°C	29°C	
17.2°C	1133	23.0	4.47	0.71	0.86	0.99	20.8	5.36	0.73	0.90	1.00	18.4	6.46	0.76	0.95	1.00	15.9	7.84	0.81	1.00	1.00
	1416	24.2	4.50	0.76	0.94	1.00	21.9	5.39	0.79	0.98	1.00	19.5	6.50	0.83	1.00	1.00	17.0	7.88	0.90	1.00	1.00
	1699	25.1	4.51	0.81	0.99	1.00	22.8	5.41	0.85	1.00	1.00	20.5	6.53	0.91	1.00	1.00	17.8	7.92	0.97	1.00	1.00
19.4°C	1133	24.3	4.50	0.56	0.69	0.82	22.0	5.39	0.57	0.71	0.86	19.6	6.50	0.57	0.74	0.91	16.8	7.88	0.59	0.78	0.98
	1416	25.6	4.52	0.59	0.74	0.90	23.2	5.42	0.60	0.76	0.95	20.5	6.53	0.62	0.81	0.99	17.5	7.91	0.64	0.88	1.00
	1699	26.5	4.54	0.62	0.79	0.97	24.0	5.44	0.63	0.82	1.00	21.1	6.55	0.65	0.88	1.00	18.0	7.94	0.69	0.96	1.00
21.7°C	1133	25.5	4.52	0.42	0.55	0.67	23.2	5.42	0.41	0.56	0.69	20.7	6.54	0.40	0.57	0.71	17.8	7.92	0.40	0.59	0.76
	1416	26.8	4.54	0.43	0.58	0.72	24.4	5.45	0.43	0.59	0.74	21.7	6.57	0.43	0.61	0.78	18.6	7.96	0.43	0.64	0.85
	1699	27.8	4.56	0.44	0.61	0.76	25.3	5.47	0.44	0.63	0.80	22.4	6.60	0.45	0.65	0.86	19.2	7.99	0.46	0.69	0.94

Entering Wet Bulb Temperature	Total Air Volume	Outdoor Air Temperature Entering Outdoor Coil									
		48°C					50°C				
		Total Cool Cap.	Comp. Motor Input	Sensible To Total Ratio (S/T)			Total Cool Cap.	Comp. Motor Input	Sensible To Total Ratio (S/T)		
				Dry Bulb					Dry Bulb		
L/s	kW	kW	24°C	27°C	29°C	kW	kW	24°C	27°C	29°C	
17.2°C	1135	17.0	7.19	0.78	0.98	1.00	16.4	7.53	0.80	0.99	1.00
	1415	18.1	7.23	0.87	1.00	1.00	17.5	7.58	0.88	1.00	1.00
	1700	19.0	7.27	0.94	1.00	1.00	18.3	7.61	0.96	1.00	1.00
19.4°C	1135	18.1	7.23	0.58	0.76	0.95	17.4	7.58	0.59	0.77	0.97
	1415	18.9	7.26	0.63	0.84	1.00	18.1	7.60	0.64	0.86	1.00
	1700	19.4	7.29	0.67	0.92	1.00	18.7	7.63	0.68	0.94	1.00
21.7°C	1135	19.1	7.27	0.40	0.58	0.74	18.4	7.61	0.40	0.58	0.75
	1415	20.0	7.31	0.43	0.62	0.82	19.3	7.65	0.43	0.63	0.83
	1700	20.6	7.33	0.45	0.67	0.90	19.8	7.68	0.45	0.68	0.92

RATINGS

NOTE – For Temperatures and Capacities not shown in tables, see bulletin – Cooling Unit Rating Table Correction Factor Data in Miscellaneous Engineering Data section.

30 KW STANDARD EFFICIENCY ZGA102S4B (1ST STAGE) - CONSTANT AIR VOLUME

Entering Wet Bulb Temperature	Total Air Volume	Outdoor Air Temperature Entering Outdoor Coil																			
		18.3°C					23.9°C					29.4°C					35°C				
		Total Cool Cap.	Comp. Motor Input	Sensible To Total Ratio (S/T)			Total Cool Cap.	Comp. Motor Input	Sensible To Total Ratio (S/T)			Total Cool Cap.	Comp. Motor Input	Sensible To Total Ratio (S/T)			Total Cool Cap.	Comp. Motor Input	Sensible To Total Ratio (S/T)		
				Dry Bulb					Dry Bulb					Dry Bulb					Dry Bulb		
L/s	kW	kW	24°C	27°C	29°C	kW	kW	24°C	27°C	29°C	kW	kW	24°C	27°C	29°C	kW	kW	24°C	27°C	29°C	
17.2°C	1284	17.3	2.23	0.70	0.84	0.96	16.6	2.56	0.71	0.86	0.97	15.8	2.90	0.72	0.87	0.97	15.0	3.29	0.73	0.89	0.97
	1605	18.1	2.25	0.73	0.90	0.96	17.3	2.57	0.74	0.91	0.96	16.5	2.92	0.76	0.93	0.96	15.7	3.31	0.76	0.95	0.96
	1926	18.6	2.25	0.76	0.94	0.96	17.9	2.58	0.77	0.95	0.96	17.1	2.93	0.79	0.95	0.96	16.2	3.32	0.80	0.94	0.95
19.4°C	1284	18.1	2.25	0.54	0.67	0.80	17.3	2.57	0.54	0.68	0.82	16.6	2.92	0.54	0.69	0.83	15.8	3.31	0.55	0.71	0.85
	1605	19.0	2.26	0.55	0.71	0.86	18.1	2.58	0.56	0.72	0.88	17.3	2.93	0.56	0.73	0.89	16.3	3.32	0.57	0.74	0.91
	1926	19.5	2.26	0.56	0.74	0.91	18.6	2.59	0.57	0.75	0.92	17.7	2.94	0.57	0.76	0.94	16.7	3.33	0.58	0.78	0.94
21.7°C	1284	18.8	2.25	0.38	0.52	0.64	18.1	2.58	0.39	0.53	0.65	17.2	2.93	0.38	0.53	0.66	16.4	3.32	0.39	0.53	0.68
	1605	19.6	2.26	0.39	0.53	0.68	18.8	2.59	0.39	0.54	0.69	17.8	2.94	0.38	0.55	0.7	16.9	3.33	0.39	0.55	0.72
	1926	20.1	2.27	0.38	0.55	0.71	19.2	2.59	0.38	0.55	0.72	18.2	2.95	0.38	0.56	0.74	17.2	3.33	0.37	0.57	0.75

30 KW STANDARD EFFICIENCY ZGA102S4B (2ND STAGE) - CONSTANT AIR VOLUME

Entering Wet Bulb Temperature	Total Air Volume	Outdoor Air Temperature Entering Outdoor Coil																			
		26.7°C					35°C					43.3°C					51.7°C				
		Total Cool Cap.	Comp. Motor Input	Sensible To Total Ratio (S/T)			Total Cool Cap.	Comp. Motor Input	Sensible To Total Ratio (S/T)			Total Cool Cap.	Comp. Motor Input	Sensible To Total Ratio (S/T)			Total Cool Cap.	Comp. Motor Input	Sensible To Total Ratio (S/T)		
				Dry Bulb					Dry Bulb					Dry Bulb					Dry Bulb		
L/s	kW	kW	24°C	27°C	29°C	kW	kW	24°C	27°C	29°C	kW	kW	24°C	27°C	29°C	kW	kW	24°C	27°C	29°C	
17.2°C	1284	25.4	5.08	0.78	0.91	0.98	23.4	6.11	0.80	0.94	0.99	21.3	7.33	0.84	0.97	0.98	18.9	8.82	0.88	0.98	0.98
	1605	26.6	5.11	0.83	0.96	0.98	24.6	6.15	0.86	0.97	0.98	22.5	7.38	0.89	0.98	0.98	20.0	8.87	0.94	0.98	0.98
	1926	27.7	5.14	0.87	0.98	0.98	25.7	6.18	0.90	0.98	0.98	23.5	7.42	0.94	0.97	0.98	20.9	8.90	0.96	0.97	0.98
19.4°C	1284	26.9	5.12	0.60	0.75	0.88	24.8	6.16	0.62	0.78	0.91	22.5	7.38	0.64	0.81	0.94	19.8	8.86	0.67	0.86	0.97
	1605	28.2	5.15	0.63	0.80	0.94	25.9	6.19	0.65	0.84	0.96	23.4	7.41	0.67	0.87	0.97	20.4	8.89	0.71	0.92	0.97
	1926	29.0	5.17	0.66	0.85	0.97	26.6	6.21	0.68	0.88	0.97	23.9	7.43	0.71	0.92	0.97	21.0	8.91	0.76	0.96	0.97
21.7°C	1284	28.4	5.16	0.44	0.58	0.72	26.2	6.20	0.44	0.60	0.75	23.8	7.43	0.45	0.62	0.78	21.0	8.91	0.46	0.65	0.84
	1605	29.7	5.18	0.45	0.61	0.77	27.4	6.23	0.45	0.63	0.81	24.7	7.46	0.46	0.66	0.85	21.7	8.94	0.47	0.70	0.90
	1926	30.7	5.20	0.45	0.65	0.83	28.2	6.26	0.46	0.67	0.86	25.4	7.48	0.47	0.7	0.9	22.2	8.95	0.49	0.74	0.95

Entering Wet Bulb Temperature	Total Air Volume	Outdoor Air Temperature Entering Outdoor Coil									
		48°C					50°C				
		Total Cool Cap.	Comp. Motor Input	Sensible To Total Ratio (S/T)			Total Cool Cap.	Comp. Motor Input	Sensible To Total Ratio (S/T)		
				Dry Bulb					Dry Bulb		
L/s	kW	kW	24°C	27°C	29°C	kW	kW	24°C	27°C	29°C	
17.2°C	1285	20.0	8.12	0.86	0.98	0.98	19.4	8.49	0.87	0.98	0.98
	1605	21.2	8.17	0.92	0.98	0.98	20.6	8.53	0.93	0.98	0.98
	1925	22.2	8.21	0.96	0.97	0.98	21.5	8.57	0.96	0.97	0.98
19.4°C	1285	21.1	8.17	0.65	0.84	0.97	20.3	8.53	0.66	0.85	0.97
	1605	21.8	8.19	0.69	0.90	0.97	21.0	8.56	0.70	0.91	0.97
	1925	22.4	8.22	0.73	0.94	0.97	21.6	8.58	0.74	0.95	0.97
21.7°C	1285	22.3	8.21	0.45	0.63	0.81	21.6	8.58	0.45	0.64	0.82
	1605	23.1	8.24	0.47	0.68	0.87	22.3	8.61	0.47	0.69	0.89
	1925	23.7	8.26	0.48	0.72	0.92	22.9	8.63	0.48	0.73	0.94

RATINGS

NOTE – For Temperatures and Capacities not shown in tables, see bulletin – Cooling Unit Rating Table Correction Factor Data in Miscellaneous Engineering Data section.

35 KW STANDARD EFFICIENCY ZGA120S4B (1ST STAGE) - CONSTANT AIR VOLUME

Entering Wet Bulb Temperature	Total Air Volume	Outdoor Air Temperature Entering Outdoor Coil																			
		18.3°C					23.9°C					29.4°C					35°C				
		Total Cool Cap.	Comp. Motor Input	Sensible To Total Ratio (S/T)			Total Cool Cap.	Comp. Motor Input	Sensible To Total Ratio (S/T)			Total Cool Cap.	Comp. Motor Input	Sensible To Total Ratio (S/T)			Total Cool Cap.	Comp. Motor Input	Sensible To Total Ratio (S/T)		
				Dry Bulb					Dry Bulb					Dry Bulb					Dry Bulb		
L/s	kW	kW	24°C	27°C	29°C	kW	kW	24°C	27°C	29°C	kW	kW	24°C	27°C	29°C	kW	kW	24°C	27°C	29°C	
17.2°C	1510	16.1	2.32	0.69	0.85	1.00	15.0	2.63	0.69	0.86	1.00	13.7	2.98	0.70	0.88	1.00	12.4	3.37	0.71	0.91	1.00
	1888	17.1	2.32	0.75	0.93	1.00	15.9	2.64	0.75	0.96	1.00	14.6	3.00	0.76	0.98	1.00	13.3	3.39	0.78	1.00	1.00
	2265	17.9	2.33	0.80	1.00	1.00	16.7	2.65	0.81	1.00	1.00	15.4	3.01	0.83	1.00	1.00	14.2	3.41	0.86	1.00	1.00
19.4°C	1510	17.3	2.32	0.55	0.67	0.81	16.1	2.64	0.54	0.67	0.82	14.8	3.00	0.53	0.68	0.84	13.5	3.40	0.52	0.69	0.87
	1888	18.3	2.34	0.57	0.72	0.90	17.0	2.65	0.57	0.74	0.92	15.6	3.02	0.57	0.74	0.94	14.3	3.41	0.57	0.76	0.98
	2265	19.0	2.34	0.61	0.78	0.97	17.6	2.66	0.61	0.79	0.99	16.3	3.03	0.6	0.81	1.00	14.8	3.43	0.61	0.83	1.00
21.7°C	1510	18.6	2.34	0.41	0.54	0.65	17.3	2.66	0.4	0.53	0.66	15.9	3.02	0.38	0.52	0.66	14.6	3.42	0.36	0.52	0.67
	1888	19.5	2.35	0.42	0.57	0.70	18.1	2.67	0.42	0.57	0.72	16.8	3.04	0.4	0.57	0.73	15.3	3.44	0.39	0.57	0.74
	2265	20.2	2.35	0.45	0.61	0.76	18.8	2.68	0.44	0.61	0.77	17.3	3.05	0.42	0.6	0.79	15.8	3.45	0.4	0.61	0.81

35 KW STANDARD EFFICIENCY ZGA120S4B (2ND STAGE) - CONSTANT AIR VOLUME

Entering Wet Bulb Temperature	Total Air Volume	Outdoor Air Temperature Entering Outdoor Coil																			
		26.7°C					35°C					43.3°C					51.7°C				
		Total Cool Cap.	Comp. Motor Input	Sensible To Total Ratio (S/T)			Total Cool Cap.	Comp. Motor Input	Sensible To Total Ratio (S/T)			Total Cool Cap.	Comp. Motor Input	Sensible To Total Ratio (S/T)			Total Cool Cap.	Comp. Motor Input	Sensible To Total Ratio (S/T)		
				Dry Bulb					Dry Bulb					Dry Bulb					Dry Bulb		
L/s	kW	kW	24°C	27°C	29°C	kW	kW	24°C	27°C	29°C	kW	kW	24°C	27°C	29°C	kW	kW	24°C	27°C	29°C	
17.2°C	1510	30.4	5.70	0.71	0.88	1.00	26.5	6.86	0.72	0.92	1.00	22.2	8.23	0.74	0.98	1.00	17.9	9.90	0.78	1.00	1.00
	1888	32.3	5.72	0.78	0.98	1.00	28.3	6.90	0.80	1.00	1.00	24.2	8.29	0.84	1.00	1.00	19.9	9.97	0.91	1.00	1.00
	2265	34.1	5.75	0.84	1.00	1.00	30.1	6.94	0.88	1.00	1.00	25.9	8.34	0.93	1.00	1.00	21.3	10.03	1.00	1.00	1.00
19.4°C	1510	32.9	5.73	0.54	0.69	0.84	28.8	6.91	0.53	0.70	0.88	24.3	8.30	0.52	0.72	0.93	19.5	9.96	0.50	0.75	1.00
	1888	34.7	5.76	0.59	0.76	0.94	30.3	6.95	0.58	0.78	0.98	25.6	8.33	0.58	0.81	1.00	20.6	10.00	0.58	0.88	1.00
	2265	36.0	5.78	0.62	0.82	1.00	31.4	6.97	0.63	0.85	1.00	26.7	8.37	0.63	0.91	1.00	21.6	10.04	0.65	0.98	1.00
21.7°C	1510	35.3	5.76	0.40	0.54	0.67	31.1	6.96	0.37	0.53	0.68	26.5	8.36	0.33	0.52	0.70	21.5	10.04	0.28	0.51	0.73
	1888	37.2	5.80	0.42	0.58	0.74	32.7	7.00	0.4	0.58	0.76	27.9	8.40	0.37	0.58	0.79	22.7	10.08	0.33	0.59	0.85
	2265	38.5	5.82	0.44	0.62	0.80	33.8	7.03	0.42	0.62	0.83	28.9	8.44	0.4	0.64	0.88	23.5	10.12	0.36	0.66	0.96

Entering Wet Bulb Temperature	Total Air Volume	Outdoor Air Temperature Entering Outdoor Coil									
		48°C					50°C				
		Total Cool Cap.	Comp. Motor Input	Sensible To Total Ratio (S/T)			Total Cool Cap.	Comp. Motor Input	Sensible To Total Ratio (S/T)		
				Dry Bulb					Dry Bulb		
L/s	kW	kW	24°C	27°C	29°C	kW	kW	24°C	27°C	29°C	
17.2°C	1510	19.8	9.12	0.76	1.00	1.00	18.8	9.53	0.76	1.00	1.00
	1890	21.8	9.19	0.87	1.00	1.00	20.8	9.60	0.89	1.00	1.00
	2265	23.4	9.24	0.97	1.00	1.00	22.3	9.66	0.99	1.00	1.00
19.4°C	1510	21.7	9.18	0.51	0.74	0.97	20.5	9.59	0.51	0.74	0.99
	1890	22.9	9.23	0.58	0.84	1.00	21.7	9.64	0.58	0.86	1.00
	2265	23.9	9.26	0.64	0.95	1.00	22.6	9.67	0.64	0.97	1.00
21.7°C	1510	23.8	9.25	0.31	0.52	0.72	22.6	9.67	0.29	0.52	0.73
	1890	25.1	9.30	0.34	0.58	0.82	23.8	9.71	0.33	0.59	0.83
	2265	25.9	9.33	0.38	0.65	0.92	24.6	9.74	0.37	0.65	0.94

RATINGS

NOTE – For Temperatures and Capacities not shown in tables, see bulletin – Cooling Unit Rating Table Correction Factor Data in Miscellaneous Engineering Data section.

44 KW STANDARD EFFICIENCY ZGA150S4B (1ST STAGE) - CONSTANT AIR VOLUME

Entering Wet Bulb Temperature	Total Air Volume	Outdoor Air Temperature Entering Outdoor Coil																			
		18.3°C					23.9°C					29.4°C					35°C				
		Total Cool Cap.	Comp. Motor Input	Sensible To Total Ratio (S/T)			Total Cool Cap.	Comp. Motor Input	Sensible To Total Ratio (S/T)			Total Cool Cap.	Comp. Motor Input	Sensible To Total Ratio (S/T)			Total Cool Cap.	Comp. Motor Input	Sensible To Total Ratio (S/T)		
				Dry Bulb					Dry Bulb					Dry Bulb					Dry Bulb		
L/s	kW	kW	24°C	27°C	29°C	kW	kW	24°C	27°C	29°C	kW	kW	24°C	27°C	29°C	kW	kW	24°C	27°C	29°C	
17.2°C	1793	20.4	2.79	0.66	0.83	1.00	19.0	3.13	0.67	0.86	1.00	17.5	3.51	0.68	0.88	1.00	16.0	3.94	0.69	0.92	1.00
	2077	21.2	2.81	0.70	0.9	1.00	19.7	3.15	0.71	0.93	1.00	18.2	3.53	0.72	0.97	1.00	16.6	3.96	0.74	1.00	1.00
	2360	21.9	2.82	0.74	0.96	1.00	20.3	3.17	0.76	0.99	1.00	18.8	3.55	0.77	1.00	1.00	17.3	3.98	0.80	1.00	1.00
19.4°C	1793	21.9	2.82	0.52	0.64	0.79	20.4	3.17	0.52	0.65	0.81	18.8	3.55	0.52	0.66	0.84	17.2	3.98	0.51	0.67	0.87
	2077	22.7	2.84	0.54	0.68	0.85	21.1	3.19	0.54	0.68	0.88	19.5	3.57	0.54	0.70	0.92	17.8	4.00	0.54	0.72	0.96
	2360	23.3	2.86	0.57	0.72	0.92	21.7	3.21	0.57	0.73	0.96	20.1	3.59	0.57	0.75	0.99	18.3	4.01	0.57	0.77	1.00
21.7°C	1793	23.3	2.86	0.39	0.51	0.63	21.8	3.21	0.38	0.51	0.63	20.2	3.59	0.37	0.51	0.64	18.5	4.02	0.36	0.51	0.65
	2077	24.1	2.88	0.41	0.54	0.66	22.5	3.23	0.4	0.54	0.67	20.9	3.61	0.39	0.54	0.68	19.1	4.04	0.38	0.54	0.70
	2360	24.7	2.90	0.42	0.56	0.70	23.1	3.25	0.41	0.56	0.71	21.4	3.63	0.4	0.56	0.73	19.6	4.06	0.39	0.57	0.75

44 KW STANDARD EFFICIENCY ZGA150S4B (2ND STAGE) - CONSTANT AIR VOLUME

Entering Wet Bulb Temperature	Total Air Volume	Outdoor Air Temperature Entering Outdoor Coil																			
		26.7°C					35°C					43.3°C					51.7°C				
		Total Cool Cap.	Comp. Motor Input	Sensible To Total Ratio (S/T)			Total Cool Cap.	Comp. Motor Input	Sensible To Total Ratio (S/T)			Total Cool Cap.	Comp. Motor Input	Sensible To Total Ratio (S/T)			Total Cool Cap.	Comp. Motor Input	Sensible To Total Ratio (S/T)		
				Dry Bulb					Dry Bulb					Dry Bulb					Dry Bulb		
L/s	kW	kW	24°C	27°C	29°C	kW	kW	24°C	27°C	29°C	kW	kW	24°C	27°C	29°C	kW	kW	24°C	27°C	29°C	
17.2°C	1793	36.9	6.72	0.73	0.9	1.00	32.2	7.99	0.75	0.95	1.00	27.3	9.52	0.78	1.00	1.00	22.4	11.46	0.83	1.00	1.00
	2077	38.3	6.77	0.78	0.96	1.00	33.6	8.03	0.80	1.00	1.00	28.8	9.57	0.84	1.00	1.00	23.9	11.53	0.91	1.00	1.00
	2360	39.6	6.80	0.82	1.00	1.00	35.1	8.08	0.85	1.00	1.00	30.3	9.64	0.90	1.00	1.00	25.0	11.57	0.99	1.00	1.00
19.4°C	1793	39.7	6.80	0.56	0.71	0.87	34.8	8.07	0.56	0.73	0.91	29.7	9.61	0.56	0.76	0.96	23.9	11.53	0.54	0.80	1.00
	2077	41.1	6.84	0.59	0.76	0.93	36.0	8.11	0.59	0.78	0.98	30.6	9.65	0.59	0.82	1.00	24.8	11.56	0.60	0.88	1.00
	2360	42.2	6.88	0.62	0.8	0.98	37.0	8.15	0.62	0.83	1.00	31.4	9.68	0.63	0.88	1.00	25.5	11.59	0.65	0.96	1.00
21.7°C	1793	42.4	6.88	0.41	0.55	0.69	37.4	8.16	0.39	0.55	0.71	32.1	9.70	0.36	0.56	0.74	26.1	11.61	0.33	0.55	0.78
	2077	43.8	6.93	0.42	0.58	0.74	38.6	8.20	0.41	0.59	0.76	33.1	9.74	0.38	0.6	0.80	27.0	11.65	0.35	0.61	0.86
	2360	45.0	6.97	0.44	0.62	0.78	39.6	8.24	0.42	0.62	0.81	33.9	9.78	0.40	0.63	0.86	27.7	11.68	0.37	0.65	0.94

Entering Wet Bulb Temperature	Total Air Volume	Outdoor Air Temperature Entering Outdoor Coil									
		48°C					50°C				
		Total Cool Cap.	Comp. Motor Input	Sensible To Total Ratio (S/T)			Total Cool Cap.	Comp. Motor Input	Sensible To Total Ratio (S/T)		
				Dry Bulb					Dry Bulb		
L/s	kW	kW	24°C	27°C	29°C	kW	kW	24°C	27°C	29°C	
17.2°C	1795	24.5	10.55	0.80	1.00	1.00	23.4	11.03	0.81	1.00	1.00
	2075	26.1	10.61	0.87	1.00	1.00	24.9	11.10	0.89	1.00	1.00
	2360	27.5	10.66	0.94	1.00	1.00	26.1	11.14	0.96	1.00	1.00
19.4°C	1795	26.5	10.62	0.55	0.78	1.00	25.1	11.10	0.55	0.79	1.00
	2075	27.4	10.66	0.60	0.85	1.00	26.1	11.13	0.60	0.87	1.00
	2360	28.2	10.69	0.64	0.92	1.00	26.7	11.16	0.64	0.94	1.00
21.7°C	1795	28.8	10.72	0.35	0.56	0.76	27.5	11.19	0.33	0.55	0.77
	2075	29.7	10.75	0.36	0.60	0.83	28.3	11.22	0.36	0.60	0.85
	2360	30.5	10.78	0.39	0.64	0.90	29.0	11.25	0.38	0.65	0.92

BLOWER DATA

092 STANDARD EFFICIENCY BELT DRIVE BLOWER – BASE UNIT

BLOWER TABLE INCLUDES RESISTANCE FOR BASE UNIT ONLY (NO HEAT SECTION) WITH DRY INDOOR COIL AND AIR FILTERS IN PLACE. FOR ALL UNITS ADD:

- 1 – Wet indoor coil air resistance of selected unit.
- 2 – Any factory installed options air resistance (heat section, economizer, etc.)
- 3 – Any field installed accessories air resistance (duct resistance, diffuser, etc.)

Then determine from blower table blower motor output required.

See page 22 for blower motors and drives.

See page 22 for wet coil and option/accessory air resistance data.

MAXIMUM STATIC PRESSURE WITH GAS HEAT - 500 Pa (2.0 in. w.g.)

Air Volume		TOTAL STATIC PRESSURE - Pa (Inches Water Gauge)																				
		50 (0.20)			100 (0.40)			150 (0.60)			200 (0.80)			250 (1.00)			300 (1.20)			350 (1.40)		
L/s	cfm	rev/min	kW	BHP	rev/min	kW	BHP	rev/min	kW	BHP	rev/min	kW	BHP	rev/min	kW	BHP	rev/min	kW	BHP	rev/min	kW	BHP
825	1750	498	0.06	0.08	565	0.19	0.25	633	0.37	0.5	701	0.53	0.71	768	0.65	0.87	830	0.74	0.99	890	0.81	1.08
945	2000	512	0.09	0.12	578	0.28	0.37	645	0.45	0.6	713	0.60	0.81	780	0.72	0.97	842	0.82	1.1	901	0.89	1.19
1060	2250	527	0.18	0.24	592	0.37	0.49	659	0.54	0.72	727	0.69	0.92	793	0.81	1.08	855	0.90	1.21	913	0.98	1.32
1180	2500	543	0.28	0.37	608	0.46	0.61	675	0.63	0.84	743	0.78	1.04	809	0.90	1.21	869	1.01	1.35	926	1.08	1.45
1300	2750	560	0.38	0.51	625	0.56	0.75	693	0.73	0.98	761	0.88	1.18	826	1.01	1.35	885	1.11	1.49	939	1.19	1.6
1415	3000	579	0.49	0.66	645	0.67	0.9	713	0.84	1.13	781	1.00	1.34	844	1.13	1.51	901	1.23	1.65	954	1.32	1.77
1535	3250	600	0.61	0.82	666	0.79	1.06	735	0.97	1.3	803	1.13	1.51	864	1.26	1.69	918	1.36	1.82	969	1.45	1.95
1650	3500	622	0.73	0.98	690	0.93	1.24	760	1.11	1.49	826	1.27	1.7	883	1.40	1.87	936	1.50	2.01	985	1.61	2.16
1770	3750	646	0.87	1.17	716	1.08	1.45	786	1.27	1.7	849	1.42	1.91	903	1.54	2.07	953	1.65	2.21	1002	1.78	2.38
1890	4000	674	1.03	1.38	746	1.25	1.68	814	1.44	1.93	872	1.58	2.12	923	1.70	2.28	971	1.81	2.43	1019	1.97	2.64
2005	4250	705	1.22	1.63	777	1.45	1.94	841	1.62	2.17	894	1.75	2.34	943	1.87	2.5	990	2.01	2.69	1038	2.19	2.93

Air Volume		TOTAL STATIC PRESSURE - Pa (Inches Water Gauge)																	
		400 (1.60)			450 (1.80)			500 (2.00)			550 (2.20)			600 (2.40)			650 (2.60)		
L/s	cfm	rev/min	kW	BHP	rev/min	kW	BHP	rev/min	kW	BHP	rev/min	kW	BHP	rev/min	kW	BHP	rev/min	kW	BHP
825	1750	946	0.87	1.16	998	0.95	1.27	1049	1.05	1.41	1098	1.18	1.58	---	---	---	---	---	---
945	2000	955	0.95	1.28	1007	1.04	1.4	1057	1.16	1.56	1105	1.30	1.74	1153	1.45	1.94	1201	1.61	2.16
1060	2250	966	1.06	1.42	1017	1.16	1.55	1066	1.28	1.72	1114	1.43	1.92	1162	1.59	2.13	1210	1.75	2.35
1180	2500	978	1.17	1.57	1028	1.28	1.72	1076	1.42	1.9	1124	1.57	2.11	1171	1.74	2.33	1221	1.92	2.57
1300	2750	990	1.29	1.73	1039	1.42	1.9	1087	1.57	2.1	1135	1.73	2.32	1183	1.90	2.55	1232	2.09	2.8
1415	3000	1004	1.43	1.92	1052	1.57	2.11	1100	1.73	2.32	1147	1.91	2.56	1195	2.09	2.8	1245	2.28	3.05
1535	3250	1018	1.58	2.12	1066	1.75	2.34	1113	1.92	2.57	1161	2.10	2.81	1209	2.28	3.06	1259	2.47	3.31
1650	3500	1033	1.75	2.35	1081	1.93	2.59	1128	2.12	2.84	1176	2.31	3.09	1224	2.49	3.34	1275	2.69	3.6
1770	3750	1049	1.95	2.61	1097	2.14	2.87	1144	2.33	3.12	1192	2.52	3.38	1241	2.72	3.64	1292	2.92	3.91
1890	4000	1067	2.16	2.9	1114	2.36	3.17	1161	2.56	3.43	1209	2.75	3.69	1259	2.95	3.96	1311	3.16	4.24
2005	4250	1085	2.39	3.21	1132	2.60	3.49	1179	2.80	3.76	1228	3.01	4.03	1279	3.22	4.31	1332	3.43	4.6

BLOWER DATA

102 STANDARD EFFICIENCY BELT DRIVE BLOWER – BASE UNIT

BLOWER TABLE INCLUDES RESISTANCE FOR BASE UNIT ONLY (NO HEAT SECTION) WITH DRY INDOOR COIL AND AIR FILTERS IN PLACE. FOR ALL UNITS ADD:

- 1 – Wet indoor coil air resistance of selected unit.
- 2 – Any factory installed options air resistance (heat section, economizer, etc.)
- 3 – Any field installed accessories air resistance (duct resistance, diffuser, etc.)

Then determine from blower table blower motor output required.

See page 22 for blower motors and drives.

See page 22 for wet coil and option/accessory air resistance data.

MAXIMUM STATIC PRESSURE WITH GAS HEAT - 500 Pa (2.0 in. w.g.)

Air Volume		TOTAL STATIC PRESSURE - Pa (Inches Water Gauge)																				
		50 (0.20)			100 (0.40)			150 (0.60)			200 (0.80)			250 (1.00)			300 (1.20)			350 (1.40)		
L/s	cfm	rev/min	kW	BHP	rev/min	kW	BHP	rev/min	kW	BHP	rev/min	kW	BHP	rev/min	kW	BHP	rev/min	kW	BHP	rev/min	kW	BHP
825	1750	494	0.08	0.11	562	0.25	0.34	632	0.42	0.56	702	0.55	0.74	771	0.63	0.85	838	0.72	0.96	902	0.80	1.07
945	2000	514	0.19	0.26	581	0.37	0.49	650	0.52	0.7	719	0.65	0.87	786	0.73	0.98	852	0.81	1.09	915	0.90	1.2
1060	2250	533	0.31	0.41	599	0.46	0.62	667	0.61	0.82	735	0.74	0.99	802	0.82	1.1	866	0.90	1.21	928	0.99	1.33
1180	2500	553	0.41	0.55	619	0.57	0.76	685	0.71	0.95	753	0.82	1.1	818	0.91	1.22	881	1.00	1.34	942	1.10	1.47
1300	2750	573	0.52	0.7	638	0.67	0.9	705	0.81	1.08	771	0.91	1.22	835	1.01	1.35	897	1.11	1.49	957	1.22	1.63
1415	3000	594	0.63	0.85	659	0.78	1.05	725	0.91	1.22	791	1.01	1.36	853	1.12	1.5	915	1.23	1.65	973	1.35	1.81
1535	3250	617	0.75	1.01	682	0.90	1.2	747	1.02	1.37	812	1.13	1.52	873	1.25	1.67	934	1.37	1.83	990	1.50	2.01
1650	3500	640	0.87	1.17	706	1.01	1.36	771	1.14	1.53	834	1.27	1.7	895	1.39	1.86	954	1.51	2.03	1008	1.66	2.23
1770	3750	665	1.00	1.34	731	1.15	1.54	796	1.28	1.72	857	1.41	1.89	917	1.54	2.07	975	1.69	2.26	1027	1.85	2.48
1890	4000	692	1.15	1.54	758	1.31	1.75	822	1.44	1.93	882	1.57	2.11	940	1.72	2.3	996	1.87	2.51	1047	2.06	2.76
2005	4250	722	1.31	1.76	787	1.47	1.97	849	1.60	2.15	908	1.75	2.35	965	1.91	2.56	1018	2.08	2.79	1067	2.28	3.06

Air Volume		TOTAL STATIC PRESSURE - Pa (Inches Water Gauge)																	
		400 (1.60)			450 (1.80)			500 (2.00)			550 (2.20)			600 (2.40)			650 (2.60)		
L/s	cfm	rev/min	kW	BHP	rev/min	kW	BHP	rev/min	kW	BHP	rev/min	kW	BHP	rev/min	kW	BHP	rev/min	kW	BHP
825	1750	961	0.89	1.19	---	---	---	---	---	---	---	---	---	---	---	---	---	---	---
945	2000	972	0.98	1.32	1026	1.10	1.47	1076	1.23	1.65	---	---	---	---	---	---	---	---	---
1060	2250	984	1.09	1.46	1037	1.22	1.63	1085	1.35	1.81	1132	1.50	2.01	1178	1.65	2.21	1226	1.81	2.43
1180	2500	997	1.21	1.62	1048	1.34	1.8	1096	1.48	1.99	1142	1.64	2.2	1188	1.80	2.41	1237	1.97	2.64
1300	2750	1011	1.34	1.8	1061	1.48	1.99	1108	1.63	2.19	1154	1.80	2.41	1200	1.96	2.63	1249	2.14	2.87
1415	3000	1026	1.48	1.99	1075	1.64	2.2	1121	1.81	2.42	1167	1.97	2.64	1213	2.14	2.87	1262	2.33	3.12
1535	3250	1042	1.65	2.21	1089	1.81	2.43	1135	1.98	2.66	1181	2.16	2.9	1228	2.33	3.13	1277	2.52	3.38
1650	3500	1058	1.84	2.46	1105	2.01	2.69	1150	2.19	2.93	1196	2.36	3.17	1243	2.54	3.41	1293	2.72	3.65
1770	3750	1076	2.03	2.72	1121	2.22	2.97	1166	2.40	3.22	1212	2.58	3.46	1261	2.77	3.71	1311	2.95	3.96
1890	4000	1094	2.25	3.02	1139	2.44	3.27	1184	2.63	3.52	1230	2.81	3.77	1280	3.01	4.03	1330	3.20	4.29
2005	4250	1113	2.48	3.33	1157	2.68	3.59	1202	2.87	3.85	1250	3.07	4.11	1300	3.27	4.38	1352	3.47	4.65

BLOWER DATA

120 STANDARD EFFICIENCY BELT DRIVE BLOWER – BASE UNIT

BLOWER TABLE INCLUDES RESISTANCE FOR BASE UNIT ONLY (NO HEAT SECTION) WITH DRY INDOOR COIL AND AIR FILTERS IN PLACE. FOR ALL UNITS ADD:

- 1 – Wet indoor coil air resistance of selected unit.
- 2 – Any factory installed options air resistance (heat section, economizer, etc.)
- 3 – Any field installed accessories air resistance (duct resistance, diffuser, etc.)

Then determine from blower table blower motor output required.

See page 22 for blower motors and drives.

See page 22 for wet coil and option/accessory air resistance data.

MAXIMUM STATIC PRESSURE WITH GAS HEAT - 500 Pa (2.0 in. w.g.)

Air Volume		TOTAL STATIC PRESSURE - Pa (Inches Water Gauge)																				
		50 (0.20)			100 (0.40)			150 (0.60)			200 (0.80)			250 (1.00)			300 (1.20)			350 (1.40)		
L/s	cfm	rev/min	kW	BHP	rev/min	kW	BHP	rev/min	kW	BHP	rev/min	kW	BHP	rev/min	kW	BHP	rev/min	kW	BHP	rev/min	kW	BHP
945	2000	535	0.21	0.28	596	0.37	0.49	660	0.51	0.69	724	0.65	0.87	788	0.75	1	851	0.83	1.11	913	0.92	1.23
1060	2250	552	0.32	0.43	613	0.47	0.63	675	0.60	0.81	738	0.73	0.98	802	0.83	1.11	864	0.91	1.22	925	1.01	1.36
1180	2500	570	0.43	0.57	630	0.57	0.76	692	0.70	0.94	754	0.82	1.1	817	0.91	1.22	879	1.01	1.35	939	1.13	1.51
1300	2750	589	0.54	0.72	648	0.68	0.91	709	0.81	1.08	772	0.91	1.22	833	1.01	1.36	894	1.12	1.5	954	1.25	1.67
1415	3000	608	0.65	0.87	668	0.78	1.05	729	0.91	1.22	791	1.02	1.37	852	1.13	1.51	912	1.25	1.67	970	1.38	1.85
1535	3250	629	0.77	1.03	688	0.90	1.21	749	1.02	1.37	811	1.13	1.52	871	1.25	1.68	930	1.39	1.86	987	1.54	2.06
1650	3500	651	0.90	1.2	710	1.03	1.38	772	1.15	1.54	833	1.27	1.7	892	1.40	1.88	950	1.54	2.07	1004	1.70	2.28
1770	3750	674	1.01	1.36	734	1.16	1.56	796	1.29	1.73	856	1.42	1.9	914	1.57	2.1	970	1.72	2.3	1023	1.89	2.53
1890	4000	699	1.16	1.55	761	1.31	1.76	822	1.45	1.94	880	1.58	2.12	936	1.74	2.33	991	1.91	2.56	1042	2.10	2.81
2005	4250	726	1.32	1.77	789	1.48	1.98	849	1.61	2.16	904	1.77	2.37	959	1.93	2.59	1012	2.12	2.84	1062	2.32	3.11
2125	4500	756	1.50	2.01	818	1.66	2.22	875	1.80	2.41	929	1.96	2.63	983	2.15	2.88	1034	2.35	3.15	1082	2.57	3.44
2240	4750	788	1.69	2.27	848	1.84	2.47	902	2.00	2.68	955	2.18	2.92	1006	2.39	3.2	1056	2.61	3.5	1104	2.83	3.79
2360	5000	822	1.89	2.54	878	2.05	2.75	929	2.22	2.98	980	2.42	3.25	1031	2.66	3.56	1079	2.89	3.87	1126	3.10	4.16

Air Volume		TOTAL STATIC PRESSURE - Pa (Inches Water Gauge)																	
		400 (1.60)			450 (1.80)			500 (2.00)			550 (2.20)			600 (2.40)			650 (2.60)		
L/s	cfm	rev/min	kW	BHP	rev/min	kW	BHP	rev/min	kW	BHP	rev/min	kW	BHP	rev/min	kW	BHP	rev/min	kW	BHP
945	2000	971	1.02	1.37	1025	1.13	1.52	1076	1.26	1.69	1124	1.39	1.86	---	---	---	---	---	---
1060	2250	982	1.13	1.51	1036	1.25	1.68	1085	1.38	1.85	1133	1.52	2.04	1180	1.66	2.23	1228	1.82	2.44
1180	2500	995	1.25	1.67	1047	1.38	1.85	1096	1.52	2.04	1143	1.66	2.23	1190	1.81	2.43	1239	1.98	2.65
1300	2750	1009	1.38	1.85	1059	1.52	2.04	1108	1.67	2.24	1154	1.82	2.44	1202	1.98	2.65	1251	2.14	2.87
1415	3000	1023	1.53	2.05	1073	1.68	2.25	1120	1.84	2.46	1167	1.99	2.67	1215	2.16	2.89	1265	2.32	3.11
1535	3250	1039	1.69	2.27	1088	1.86	2.49	1134	2.01	2.7	1181	2.18	2.92	1229	2.34	3.14	1279	2.51	3.37
1650	3500	1055	1.87	2.51	1103	2.04	2.74	1150	2.21	2.96	1196	2.38	3.19	1245	2.55	3.42	1295	2.72	3.65
1770	3750	1072	2.07	2.78	1120	2.25	3.02	1166	2.42	3.25	1213	2.59	3.47	1262	2.77	3.71	1313	2.95	3.95
1890	4000	1090	2.29	3.07	1137	2.47	3.31	1183	2.65	3.55	1231	2.82	3.78	1281	3.01	4.03	1333	3.19	4.28
2005	4250	1109	2.52	3.38	1156	2.71	3.63	1202	2.89	3.87	1251	3.07	4.11	1302	3.26	4.37	1354	3.45	4.63
2125	4500	1129	2.77	3.71	1175	2.95	3.96	1222	3.14	4.21	1271	3.33	4.46	1323	3.52	4.72	1376	3.73	5
2240	4750	1150	3.03	4.06	1196	3.22	4.32	1243	3.41	4.57	1293	3.60	4.83	1345	3.80	5.09	1399	4.01	5.37
2360	5000	1172	3.31	4.44	1218	3.51	4.7	1266	3.69	4.95	1315	3.88	5.2	1367	4.08	5.47	1421	4.28	5.74

BLOWER DATA

150 STANDARD EFFICIENCY BELT DRIVE BLOWER – BASE UNIT

BLOWER TABLE INCLUDES RESISTANCE FOR BASE UNIT ONLY (NO HEAT SECTION) WITH DRY INDOOR COIL AND AIR FILTERS IN PLACE. FOR ALL UNITS ADD:

- 1 – Wet indoor coil air resistance of selected unit.
- 2 – Any factory installed options air resistance (heat section, economizer, etc.)
- 3 – Any field installed accessories air resistance (duct resistance, diffuser, etc.)

Then determine from blower table blower motor output required.

See page 22 for blower motors and drives.

See page 22 for wet coil and option/accessory air resistance data.

MAXIMUM STATIC PRESSURE WITH GAS HEAT - 500 Pa (2.0 in. w.g.)

Air Volume		TOTAL STATIC PRESSURE - Pa (Inches Water Gauge)																				
		50 (0.20)			100 (0.40)			150 (0.60)			200 (0.80)			250 (1.00)			300 (1.20)			350 (1.40)		
L/s	cfm	rev/min	kW	BHP	rev/min	kW	BHP	rev/min	kW	BHP	rev/min	kW	BHP	rev/min	kW	BHP	rev/min	kW	BHP	rev/min	kW	BHP
945	2000	542	0.32	0.43	602	0.45	0.6	664	0.56	0.75	732	0.66	0.89	802	0.76	1.02	869	0.86	1.15	927	0.95	1.27
1060	2250	560	0.41	0.55	619	0.53	0.71	681	0.64	0.86	748	0.75	1.00	817	0.85	1.14	882	0.95	1.27	939	1.05	1.41
1180	2500	579	0.51	0.68	637	0.62	0.83	699	0.73	0.98	766	0.84	1.12	834	0.94	1.26	897	1.05	1.41	953	1.17	1.57
1300	2750	599	0.60	0.81	657	0.72	0.97	719	0.83	1.11	785	0.93	1.25	851	1.05	1.41	913	1.17	1.57	968	1.30	1.74
1415	3000	620	0.71	0.95	678	0.83	1.11	741	0.93	1.25	806	1.04	1.40	870	1.18	1.58	930	1.31	1.75	985	1.45	1.94
1535	3250	643	0.82	1.1	701	0.94	1.26	764	1.05	1.41	828	1.17	1.57	891	1.31	1.76	950	1.45	1.95	1003	1.61	2.16
1650	3500	667	0.94	1.26	726	1.07	1.43	788	1.18	1.58	851	1.32	1.77	913	1.47	1.97	970	1.62	2.17	1023	1.80	2.41
1770	3750	693	1.07	1.44	752	1.20	1.61	813	1.33	1.78	876	1.48	1.98	936	1.64	2.20	992	1.81	2.43	1043	2.00	2.68
1890	4000	720	1.23	1.65	779	1.36	1.82	840	1.49	2.00	902	1.66	2.22	961	1.84	2.46	1015	2.02	2.71	1064	2.22	2.98
2005	4250	748	1.39	1.86	807	1.52	2.04	868	1.67	2.24	929	1.85	2.48	986	2.05	2.75	1038	2.25	3.02	1086	2.46	3.30
2125	4500	778	1.56	2.09	837	1.70	2.28	898	1.87	2.51	957	2.07	2.78	1012	2.29	3.07	1062	2.51	3.37	1108	2.72	3.65
2240	4750	809	1.75	2.34	868	1.91	2.56	929	2.10	2.82	986	2.33	3.12	1038	2.56	3.43	1087	2.79	3.74	1132	3.01	4.03
2360	5000	841	1.95	2.62	901	2.14	2.87	960	2.36	3.17	1015	2.61	3.50	1065	2.86	3.83	1112	3.09	4.14	1157	3.30	4.43
2475	5250	875	2.19	2.93	935	2.41	3.23	992	2.66	3.56	1044	2.92	3.91	1092	3.18	4.26	1138	3.41	4.57	1182	3.62	4.85
2595	5500	911	2.46	3.3	969	2.71	3.63	1024	2.98	4.00	1074	3.26	4.37	1120	3.51	4.71	1165	3.74	5.02	1208	3.95	5.29
2715	5750	948	2.77	3.71	1004	3.04	4.08	1056	3.34	4.48	1104	3.62	4.85	1148	3.87	5.19	1192	4.10	5.49	1235	4.28	5.74
2830	6000	985	3.12	4.18	1039	3.42	4.59	1088	3.73	5.00	1134	4.01	5.37	1177	4.24	5.69	---	---	---	---	---	---
2950	6250	1022	3.51	4.7	1073	3.83	5.14	1120	4.13	5.54	---	---	---	---	---	---	---	---	---	---	---	---

Air Volume		TOTAL STATIC PRESSURE - Pa (Inches Water Gauge)																		
		400 (1.60)			450 (1.80)			500 (2.00)			550 (2.20)			600 (2.40)			650 (2.60)			
L/s	cfm	rev/min	kW	BHP	rev/min	kW	BHP	rev/min	kW	BHP	rev/min	kW	BHP	rev/min	kW	BHP	rev/min	kW	BHP	
945	2000	979	1.05	1.41	1029	1.17	1.57	1079	1.31	1.75	1129	1.45	1.95	1179	1.60	2.15	1230	1.77	2.37	
1060	2250	991	1.17	1.57	1041	1.30	1.74	1090	1.44	1.93	1140	1.59	2.13	1190	1.75	2.35	1241	1.92	2.57	
1180	2500	1005	1.30	1.74	1054	1.43	1.92	1103	1.58	2.12	1152	1.74	2.33	1202	1.90	2.55	1254	2.08	2.79	
1300	2750	1020	1.44	1.93	1068	1.59	2.13	1116	1.75	2.34	1165	1.91	2.56	1215	2.07	2.78	1268	2.25	3.01	
1415	3000	1036	1.60	2.14	1084	1.76	2.36	1131	1.92	2.58	1180	2.09	2.80	1230	2.25	3.02	1283	2.43	3.26	
1535	3250	1053	1.78	2.38	1100	1.95	2.61	1148	2.11	2.83	1196	2.28	3.06	1246	2.45	3.29	1299	2.63	3.52	
1650	3500	1071	1.98	2.65	1118	2.15	2.88	1165	2.32	3.11	1213	2.48	3.33	1264	2.66	3.57	1317	2.84	3.81	
1770	3750	1091	2.19	2.93	1137	2.36	3.17	1183	2.54	3.40	1232	2.72	3.64	1284	2.89	3.88	1338	3.08	4.13	
1890	4000	1111	2.42	3.24	1156	2.60	3.48	1203	2.78	3.72	1253	2.95	3.96	1305	3.15	4.22	1359	3.34	4.48	
2005	4250	1132	2.66	3.57	1177	2.84	3.81	1224	3.02	4.05	1274	3.22	4.31	1327	3.41	4.57	1382	3.62	4.85	
2125	4500	1154	2.92	3.92	1199	3.11	4.17	1247	3.29	4.41	1297	3.48	4.67	1350	3.69	4.94	1405	3.89	5.22	
2240	4750	1177	3.20	4.29	1223	3.39	4.54	1270	3.57	4.79	1321	3.76	5.04	1374	3.96	5.31	1428	4.16	5.58	
2360	5000	1201	3.50	4.69	1247	3.69	4.94	1295	3.86	5.18	1345	4.04	5.42	1398	4.24	5.68	---	---	---	
2475	5250	1226	3.80	5.10	1272	3.98	5.34	1320	4.16	5.57	---	---	---	---	---	---	---	---	---	
2595	5500	1253	4.13	5.53	---	---	---	---	---	---	---	---	---	---	---	---	---	---	---	---
2715	5750	---	---	---	---	---	---	---	---	---	---	---	---	---	---	---	---	---	---	---
2830	6000	---	---	---	---	---	---	---	---	---	---	---	---	---	---	---	---	---	---	---
2950	6250	---	---	---	---	---	---	---	---	---	---	---	---	---	---	---	---	---	---	---

BLOWER DATA

FACTORY INSTALLED BELT DRIVE KIT SPECIFICATIONS

Nominal kW		Maximum		Drive Kit Number	Rev/Min Range
kW	hp	kW	hp		
1.5	2	1.7	2.3	1	490 - 740
1.5	2	1.7	2.3	2	665 - 920
1.5	2	1.7	2.3	3	660 - 995
2.2	3	2.6	3.45	7	610 - 810
2.2	3	2.6	3.45	8	780 - 1000
2.2	3	2.6	3.45	9	845 - 1085
3.7	5	4.3	5.75	10	750 - 945
3.7	5	4.3	5.75	11	865 - 1095
3.7	5	4.3	5.75	12	940 - 1190

NOTE - Using total air volume and system static pressure requirements determine from blower performance tables rpm and motor output required. Maximum usable output of motors furnished are shown. If motors of comparable output are used, be sure to keep within the service factor limitations outlined on the motor nameplate.

POWER EXHAUST FAN PERFORMANCE

Return Air System Static Pressure		Air Volume Exhausted	
Pa	in. w.g.	L/s	cfm
0	0	1687	3575
12	0.05	1607	3405
25	0.10	1675	3550
37	0.15	1531	3245
50	0.20	1470	3115
62	0.25	1425	3020
75	0.30	1369	2900
87	0.35	1314	2785

FACTORY INSTALLED OPTIONS/FIELD INSTALLED ACCESSORY AIR RESISTANCE

Air Volume		Wet Indoor Coil						Gas Heat Exchanger						Economizer		Filters	
		092		102, 120		150		Standard Heat		Medium Heat		High Heat				MERV 8	MERV 13
L/s	cfm	Pa	in. w.g.	Pa	in. w.g.	Pa	in. w.g.	Pa	in. w.g.	Pa	in. w.g.	Pa	in. w.g.	Pa	in. w.g.		
825	1750	5	0.02	7	0.03	10	0.04	15	0.06	5	0.02	5	0.02	7	0.03	0.01	0.03
945	2000	5	0.02	10	0.04	12	0.05	17	0.07	12	0.05	15	0.06	12	0.05	0.01	0.03
1060	2250	7	0.03	12	0.05	15	0.06	17	0.07	17	0.07	20	0.08	15	0.06	0.01	0.04
1180	2500	7	0.03	12	0.05	17	0.07	22	0.09	25	0.10	27	0.11	20	0.08	0.01	0.05
1300	2750	10	0.04	15	0.06	20	0.08	22	0.09	27	0.11	30	0.12	22	0.09	0.02	0.05
1415	3000	12	0.05	17	0.07	22	0.09	27	0.11	30	0.12	32	0.13	27	0.11	0.02	0.06
1535	3250	12	0.05	20	0.08	25	0.10	30	0.12	37	0.15	40	0.16	32	0.13	0.02	0.06
1650	3500	15	0.06	22	0.09	27	0.11	30	0.12	40	0.16	42	0.17	37	0.15	0.03	0.07
1770	3750	17	0.07	25	0.10	32	0.13	35	0.14	47	0.19	50	0.20	42	0.17	0.03	0.08
1890	4000	17	0.07	27	0.11	35	0.14	35	0.14	52	0.21	55	0.22	47	0.19	0.04	0.08
2005	4250	20	0.08	32	0.13	37	0.15	35	0.14	60	0.24	70	0.28	52	0.21	0.04	0.09
2125	4500	22	0.09	35	0.14	42	0.17	37	0.15	65	0.26	80	0.32	60	0.24	0.04	0.09
2240	4750	25	0.10	37	0.15	45	0.18	40	0.16	72	0.29	92	0.37	65	0.26	0.05	0.10
2360	5000	25	0.10	40	0.16	50	0.20	40	0.16	85	0.34	107	0.43	72	0.29	0.06	0.10
2475	5250	27	0.11	42	0.17	55	0.22	40	0.16	92	0.37	117	0.47	80	0.32	0.06	0.11
2595	5500	30	0.12	47	0.19	57	0.23	45	0.18	109	0.44	134	0.54	85	0.34	0.07	0.12
2715	5750	32	0.13	50	0.20	62	0.25	47	0.19	122	0.49	147	0.59	92	0.37	0.07	0.12
2830	6000	35	0.14	55	0.22	67	0.27	50	0.20	134	0.54	159	0.64	99	0.40	0.08	0.13

BLOWER DATA

CEILING DIFFUSERS AIR RESISTANCE

Unit Size	RTD11 Step-Down Diffuser								FD11 Flush Diffuser	
	Air Volume		2 Ends Open		1 Side, 2 Ends Open		All Ends & Sides Open			
	Pa	in. w.g.	Pa	in. w.g.	Pa	in. w.g.	Pa	in. w.g.	Pa	in. w.g.
092 Models	1133	2400	52	0.21	45	0.18	37	0.15	35	0.14
	1227	2600	60	0.24	52	0.21	45	0.18	42	0.17
	1321	2800	67	0.27	60	0.24	52	0.21	50	0.20
	1416	3000	80	0.32	72	0.29	62	0.25	62	0.25
	1510	3200	102	0.41	92	0.37	80	0.32	77	0.31
	1604	3400	124	0.50	112	0.45	97	0.39	92	0.37
	1699	3600	152	0.61	134	0.54	119	0.48	109	0.44
	1793	3800	182	0.73	157	0.63	142	0.57	127	0.51
102 & 120 Models	1699	3600	90	0.36	70	0.28	57	0.23	37	0.15
	1793	3800	99	0.40	80	0.32	65	0.26	45	0.18
	1888	4000	109	0.44	90	0.36	72	0.29	52	0.21
	1982	4200	122	0.49	99	0.40	82	0.33	60	0.24
	2076	4400	134	0.54	109	0.44	92	0.37	67	0.27
	2171	4600	149	0.60	122	0.49	104	0.42	77	0.31
	2265	4800	162	0.65	132	0.53	114	0.46	87	0.35
	2360	5000	172	0.69	144	0.58	124	0.50	97	0.39
150 Models	2454	5200	186	0.75	154	0.62	134	0.54	107	0.43
	1982	4200	55	0.22	47	0.19	40	0.16	25	0.10
	2076	4400	70	0.28	60	0.24	50	0.20	30	0.12
	2171	4600	85	0.34	72	0.29	60	0.24	37	0.15
	2265	4800	99	0.40	85	0.34	72	0.29	47	0.19
	2360	5000	114	0.46	97	0.39	85	0.34	57	0.23
	2454	5200	129	0.52	109	0.44	97	0.39	67	0.27
	2548	5400	144	0.58	122	0.49	107	0.43	77	0.31
	2643	5600	159	0.64	134	0.54	117	0.47	87	0.35
2737	5800	174	0.70	147	0.59	127	0.51	97	0.39	

CEILING DIFFUSER AIR THROW DATA

Model No.	Air Volume		¹ Effective Throw Range			
			RTD11 Step-Down		FD11 Flush	
	L/s	cfm	m	ft.	m	ft.
092 Models	1225	2600	7 - 9	24 - 29	6 - 7	19 - 24
	1320	2800	8 - 9	25 - 30	6 - 9	20 - 28
	1415	3000	8 - 10	27 - 33	6 - 9	21 - 29
	1510	3200	9 - 11	28 - 35	7 - 9	22 - 29
	1605	3400	9 - 11	30 - 37	7 - 9	22 - 30
102, 120 Models	1700	3600	8 - 10	25 - 33	7 - 9	22 - 29
	1795	3800	8 - 11	27 - 35	7 - 9	22 - 30
	1890	4000	9 - 11	29 - 37	7 - 10	24 - 33
	1980	4200	10 - 12	32 - 40	8 - 11	26 - 35
	2075	4400	10 - 13	34 - 42	9 - 11	28 - 37
150 Models	2645	5600	12 - 15	39 - 49	9 - 11	28 - 37
	2735	5800	13 - 16	42 - 51	9 - 12	29 - 38
	2830	6000	13 - 17	44 - 54	12 - 15	40 - 50
	2925	6200	14 - 17	45 - 55	13 - 16	42 - 51
	3020	6400	14 - 17	46 - 55	13 - 16	43 - 52
	3115	6600	14 - 17	47 - 56	14 - 17	45 - 56

¹ Throw is the horizontal or vertical distance an air stream travels on leaving the outlet or diffuser before the maximum velocity is reduced to 15 m (50 ft.) per minute. Four sides open.

ELECTRICAL DATA

		ZGA092S4B			ZGA102S4B		
¹ Voltage - 50hz 3 Phase with neutral		380/420V			380/420V		
Compressor 1	Rated Load Amps	8			8		
	Locked Rotor Amps	59			59		
Compressor 2	Rated Load Amps	4			5.5		
	Locked Rotor Amps	31			37		
Outdoor Fan Motors (2)	Full Load Amps	1.3			1.3		
	(total)	(2.6)			(2.6)		
Power Exhaust (2) 0.33 kW (0.5 hp)	Full Load Amps	1.7			1.7		
	(total)	(3.4)			(3.4)		
Indoor Blower Motor	kW (hp)	1.5 (2)	2.2 (3)	3.7 (5)	1.5 (2)	2.2 (3)	3.7 (5)
	Full Load Amps	3.6	5.3	8.2	3.6	5.3	8.2
² Maximum Overcurrent Protection	Unit Only	25	25	30	25	30	30
	With (2) 0.33 kW (0.5 hp) Power Exhaust	30	30	35	30	30	35
³ Minimum Circuit Ampacity	Unit Only	21	22	25	22	24	27
	With (2) 0.33 kW (0.5 hp) Power Exhaust	24	26	29	26	27	30

NOTE - All units have a minimum Short Circuit Current Rating (SCCR) of 5000 amps.

¹ Extremes of operating range are plus and minus 10% of line voltage.

² HACR type breaker or fuse.

³ Refer to National or Canadian Electrical Code manual to determine wire, fuse and disconnect size requirements.

ELECTRICAL DATA

		ZGA120S4B			ZGA150S4B		
¹ Voltage - 50hz 3 Phase with neutral		380/420V - 3 Ph			380/420V - 3 Ph		
Compressor 1	Rated Load Amps	8			8		
	Locked Rotor Amps	59			67.1		
Compressor 2	Rated Load Amps	8			8		
	Locked Rotor Amps	59			67.1		
Outdoor Fan Motors (2)	Full Load Amps	1.3			1.5		
	(total)	(2.6)			(3)		
Power Exhaust (2) 0.33 kW (0.5 hp)	Full Load Amps	1.7			1.7		
	(total)	(3.4)			(3.4)		
Indoor Blower Motor	kW (hp)	1.5 (2)	2.2 (3)	3.7 (5)	1.5 (2)	2.2 (3)	3.7 (5)
	Full Load Amps	3.6	5.3	8.2	3.6	5.3	8.2
² Maximum Overcurrent Protection	Unit Only	30	30	35	30	30	35
	With (2) 0.33 kW (0.5 hp) Power Exhaust	35	35	40	35	35	40
³ Minimum Circuit Ampacity	Unit Only	25	26	29	25	27	30
	With (2) 0.33 kW (0.5 hp) Power Exhaust	28	30	33	28	30	33

NOTE - All units have a minimum Short Circuit Current Rating (SCCR) of 5000 amps.

¹ Extremes of operating range are plus and minus 10% of line voltage.

² HACR type breaker or fuse.

³ Refer to National or Canadian Electrical Code manual to determine wire, fuse and disconnect size requirements.

UNIT CLEARANCES

UNIT WITH ECONOMIZER

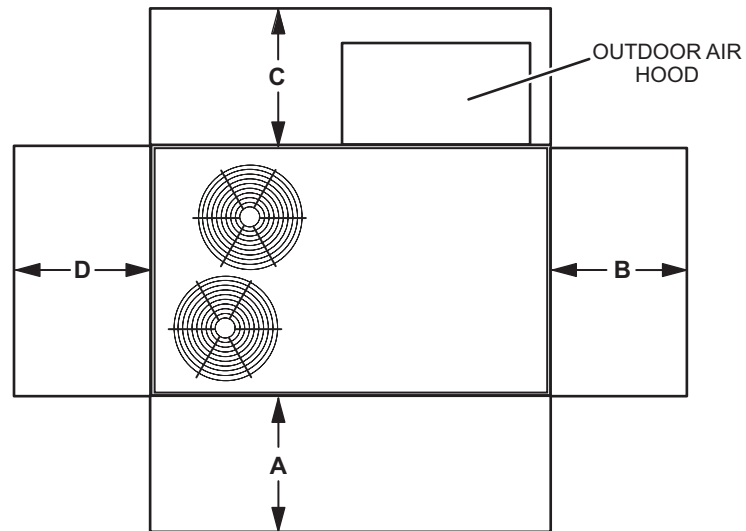

1 Unit Clearance	A		B		C		D		Top Clearance
	mm	in.	mm	in.	mm	in.	mm	in.	
Service Clearance	1524	60	914	36	914	36	1524	60	Unobstructed
Clearance to Combustibles	914	36	25	1	25	1	25	1	
Minimum Operation Clearance	914	36	914	36	914	36	914	36	

NOTE - Entire perimeter of unit base requires support when elevated above the mounting surface.

¹ Service Clearance - Required for removal of serviceable parts.

Clearance to Combustibles - Required for clearance to combustible material.

Minimum Operation Clearance - Required clearance for proper unit operation.

OUTDOOR SOUND DATA

Unit Model Number	Octave Band Linear Sound Power Levels dB, re 10 ⁻¹² Watts - Center Frequency - Hz							1 Sound Rating Number (SRN) (dBA)
	125	250	500	1000	2000	4000	8000	
092, 102 and 120	72	74	79	80	76	70	63	84
150	76	81	87	86	80	77	76	91

¹ Sound Rating Number according to ARI Standard 270-2008. "SRN" is the overall A-Weighted Sound Power Level, (LWA), dB (100 Hz to 10,000 Hz).

WEIGHT DATA

Model Number	Net		Shipping	
	kg	lbs.	kg	lbs.
092 Base Unit	409	902	448	987
092 Max. Unit	478	1053	516	1138
102 Base Unit	418	922	457	1007
102 Max. Unit	487	1073	525	1158
120 Base Unit	436	962	475	1047
120 Max. Unit	505	1113	543	1198
150 Base Unit	477	1052	516	1137
150 Max. Unit	546	1203	584	1288

OPTIONS / ACCESSORIES

Model Number	Shipping Weight	
	kg	lbs.

CABINET

Coil/Hail Guard	23	50
-----------------	----	----

CEILING DIFFUSERS

Step-Down		
RTD11-95S	118	54
RTD11-135S	135	61
RTD11-185S	168	76
Flush		
FD11-95S	118	54
FD11-135S	135	61
FD11-185S	168	76

ECONOMIZER / OUTDOOR AIR / EXHAUST**Economizer**

Downflow with Barometric Relief Dampers and Hoods	41	90
Horizontal with Barometric Relief Dampers and Hoods	43	95
Horizontal Low Profile Barometric Relief Dampers with Hood	4	8

Outdoor Air Dampers

Outdoor Air Damper Section with Hood - Automatic	26	58
Outdoor Air Damper Section with Hood - Manual	23	50

Power Exhaust

Downflow	27	60
Horizontal	19	41

GAS HEAT EXCHANGER (NET WEIGHT)

Medium Heat (adder over standard heat)	4	9
High Heat (adder over standard heat)	15	32

ROOF CURBS**Hybrid Roof Curbs, Downflow**

203 mm height	36	79
356 mm height	47	104
457 mm height	54	120
610 mm height	66	145

PACKAGING

LTL Packaging (less than truck load)	48	105
--------------------------------------	----	-----

DIMENSIONS

Model No.	CORNER WEIGHTS																CENTER OF GRAVITY							
	AA				BB				CC				DD				EE				FF			
	Base		Max		Base		Max		Base		Max		Base		Max		Base		Max		Base		Max	
	kg	lbs.	kg	lbs.	kg	lbs.	kg	lbs.	kg	lbs.	kg	lbs.	kg	lbs.	kg	lbs.	mm	in.	mm	in.	mm	in.	mm	in.
092	117	258	136	299	87	191	107	236	87	192	104	229	118	260	131	289	1207	47.5	1232	48.5	648	25.5	673	26.5
102	120	264	138	305	88	195	109	241	89	197	106	233	121	266	134	295	1207	47.5	1232	48.5	648	25.5	673	26.5
120	125	275	143	316	92	204	113	250	93	205	110	242	126	278	139	306	1207	47.5	1232	48.5	648	25.5	673	26.5
150	137	301	155	341	101	223	123	270	102	224	118	261	138	304	150	330	1207	47.5	1232	48.5	648	25.5	673	26.5

Base Unit - The unit with NO OPTIONS.

Max. Unit - The unit with ALL OPTIONS Installed. (Economizer, etc.)

BOTTOM POWER ENTRY

Holes required for Optional Bottom Power Entry Kit

	Threaded Conduit Fittings (Provided in Kit)	Wire Use	Hole Diameter Required in Unit Base (Max.)
A	¹ 1/2 in.	ACC	23 (7/8)
B	1/2 in.	24V	23 (7/8)
C	1-1/4 in.	POWER	44 (1-3/4)
D	3/4 in.	AUX	44 (1-3/4)

¹ Field provided.

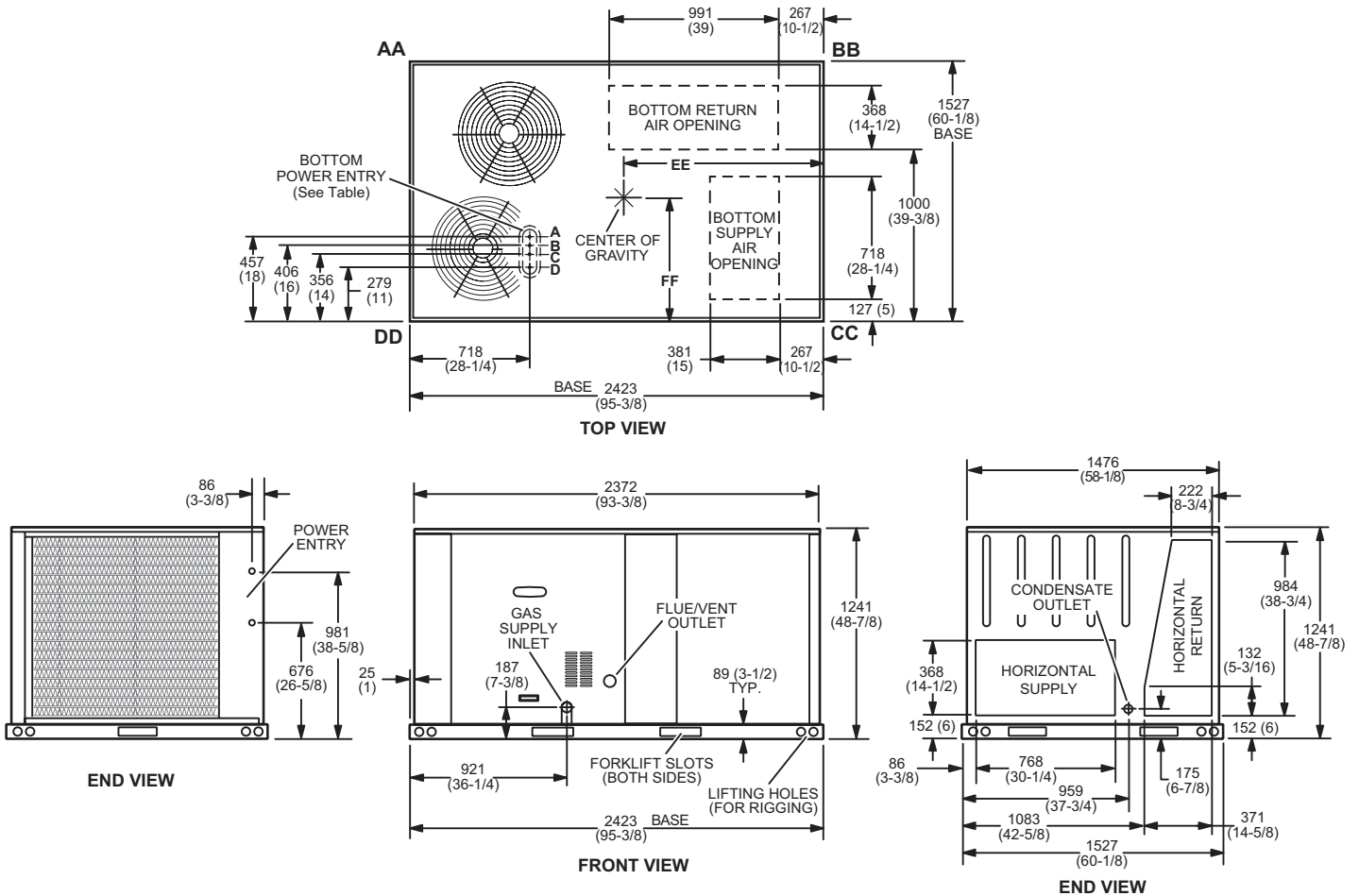

ACCESSORY DIMENSIONS

OUTDOOR AIR HOOD DETAIL FOR OPTIONAL DOWNFLOW ECONOMIZER (Downflow Applications)

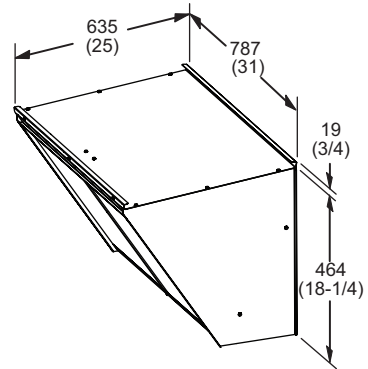
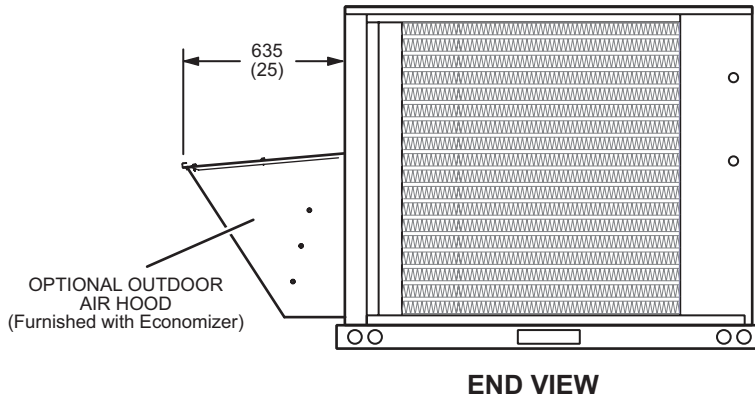

OUTDOOR AIR DAMPER HOOD DETAIL FOR OPTIONAL MANUAL OR MOTORIZED OUTDOOR AIR DAMPERS (Downflow or Horizontal Applications)

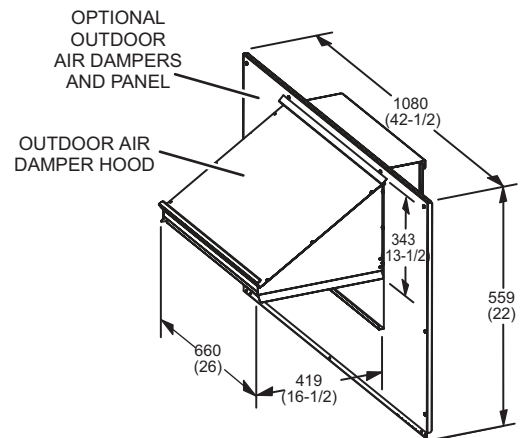
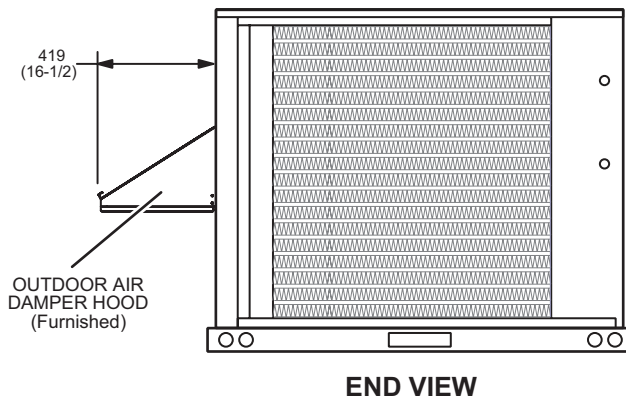

ACCESSORY DIMENSIONS

OUTDOOR AIR HOOD DETAIL WITH OPTIONAL HORIZONTAL ECONOMIZER AND BAROMETRIC RELIEF DAMPERS (Horizontal Applications)

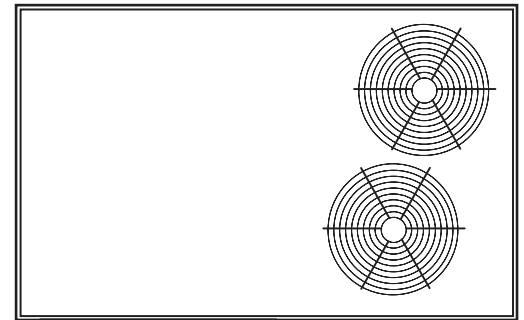

OUTDOOR AIR/
BAROMETRIC
RELIEF HOOD
(Furnished with
Economizer)

787
(31)

TOP VIEW

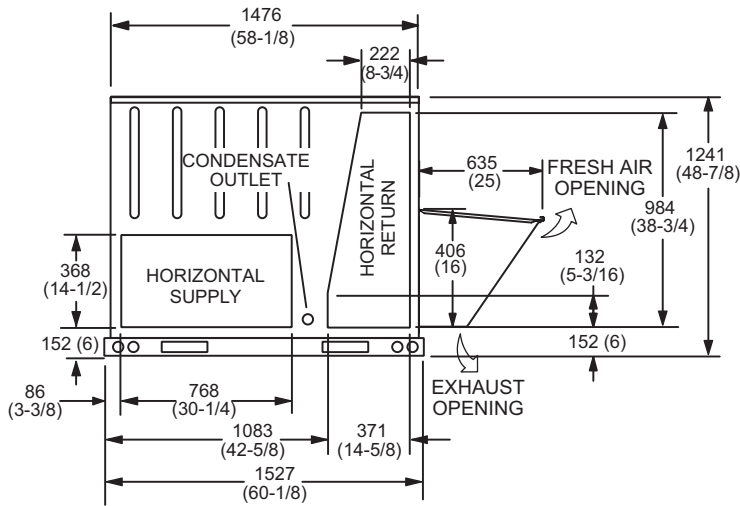

END VIEW

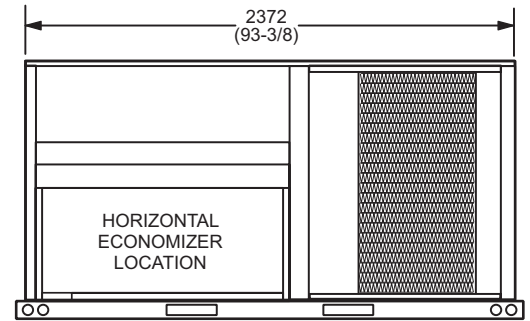

BACK VIEW

Note - Supply and Return Air Ducts must be supported.

ACCESSORY DIMENSIONS

HYBRID CURBS - DOUBLE DUCT OPENING

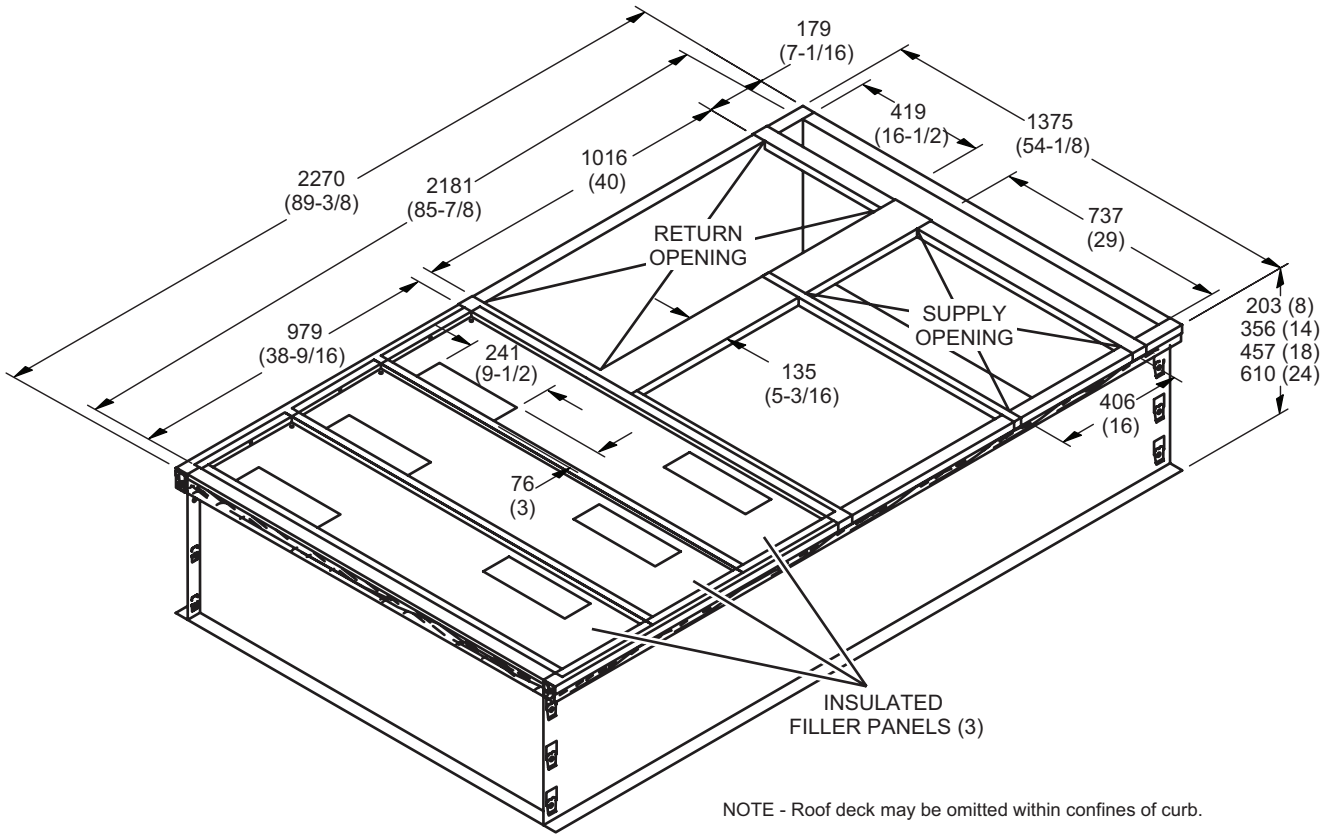

TYPICAL FLASHING DETAIL FOR ROOF CURB

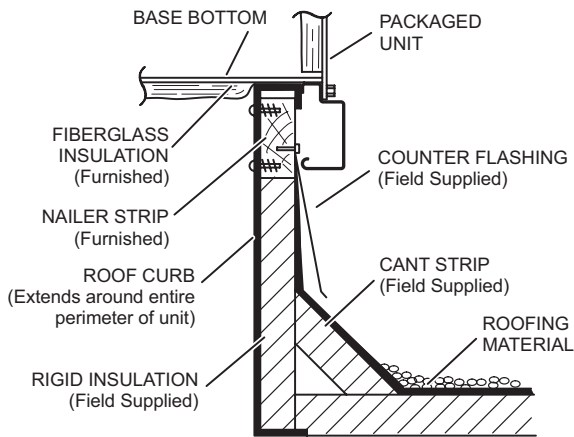

DETAIL ROOF CURB

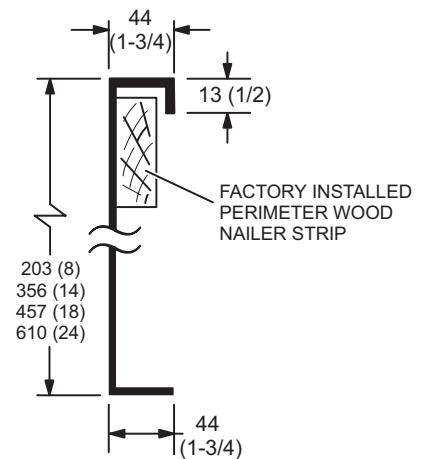

ACCESSORY DIMENSIONS

COMBINATION CEILING SUPPLY AND RETURN DIFFUSERS

STEP-DOWN CEILING DIFFUSER

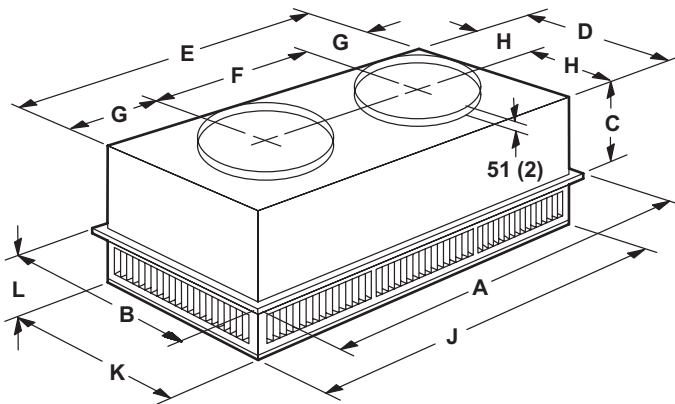

FLUSH CEILING DIFFUSER

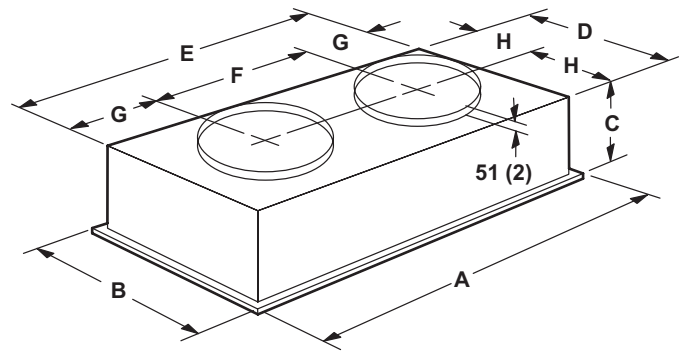

Model Number		RTD11-95S
A	mm	1159
	in.	47-5/8
B	mm	752
	in.	29-5/8
C	mm	365
	in.	14-3/8
D	mm	699
	in.	27-1/2
E	mm	1158
	in.	45-1/2
F	mm	572
	in.	22-1/2
G	mm	292
	in.	11-1/2
H	mm	349
	in.	13-3/4
J	mm	1156
	in.	45-1/2
K	mm	699
	in.	27-1/2
L	mm	206
	in.	8-1/8
Duct Size	mm	508 round
	in.	20 round

Model Number		FD11-95S
A	mm	1159
	in.	47-5/8
B	mm	752
	in.	29-5/8
C	mm	422
	in.	16-5/8
D	mm	686
	in.	27
E	mm	1143
	in.	45
F	mm	572
	in.	22-1/2
G	mm	286
	in.	11-1/4
H	mm	343
	in.	13-1/2
Duct Size	mm	508 round
	in.	20 round

ACCESSORY DIMENSIONS

COMBINATION CEILING SUPPLY AND RETURN DIFFUSERS

STEP-DOWN CEILING DIFFUSER

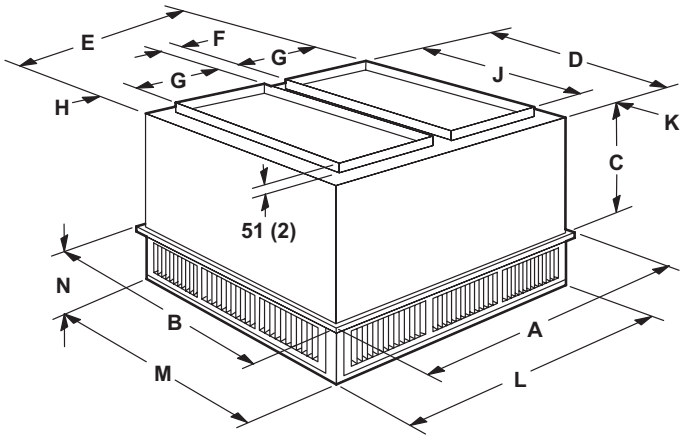

FLUSH CEILING DIFFUSER

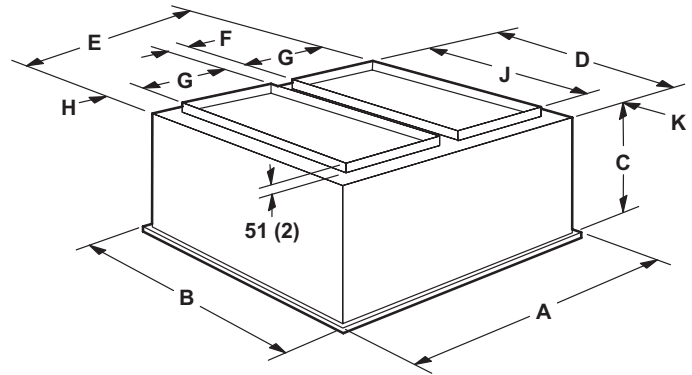

Model Number		RTD11-135S	RTD11-185S
A	mm	1210	1210
	in.	47-5/8	47-5/8
B	mm	905	1210
	in.	35-5/8	47-5/8
C	mm	524	625
	in.	20-5/8	24-5/8
D	mm	851	1156
	in.	33-1/2	45-1/2
E	mm	45-1/2	45-1/2
	in.	1156	1156
F	mm	114	114
	in.	4-1/2	4-1/2
G	mm	457	457
	in.	18	18
H	mm	64	64
	in.	2-1/2	2-1/2
J	mm	711	914
	in.	28	36
K	mm	70	121
	in.	2-3/4	4-3/4
L	mm	1156	1156
	in.	45-1/2	45-1/2
M	mm	851	1156
	in.	33-1/2	45-1/2
N	mm	232	257
	in.	9-1/8	10-1/8
Duct Size	mm	457 x 711	457 x 914
	in.	18 x 28	18 x 36

Model Number		FD11-135S	FD11-185S
A	mm	1210	1210
	in.	47-5/8	47-5/8
B	mm	905	1210
	in.	35-5/8	47-5/8
C	mm	591	743
	in.	23-1/4	29-1/4
D	mm	838	1143
	in.	33	45
E	mm	1143	1143
	in.	45	45
F	mm	114	114
	in.	4-1/2	4-1/2
G	mm	457	457
	in.	18	18
H	mm	57	57
	in.	2-1/4	2-1/4
J	mm	711	914
	in.	28	36
K	mm	64	114
	in.	2-1/2	4-1/2
Duct Size	mm	457 x 711	457 x 914
	in.	18 x 28	18 x 36

REVISIONS

Sections	Description of Change
Options/Accessories	Catalog numbers revised for: Economizers Single Enthalpy



Visit us at www.lennox.com

For the latest technical information, www.lennoxcommercial.com

Contact us at 1-800-4-LENNOX

NOTE - Due to Lennox' ongoing commitment to quality, Specifications, Ratings and Dimensions subject to change without notice and without incurring liability. Improper installation, adjustment, alteration, service or maintenance can cause property damage or personal injury. Installation and service must be performed by a qualified installer and servicing agency.

©2021 Lennox Industries, Inc.