



Heat Pumps 4HP13L

PRODUCT SPECIFICATIONS

- R-410A Refrigerant
- Quiet, durable scroll compressor with internal pressure relief valves and inherent thermal protection
- High-quality outdoor coils constructed of copper tubes with enhanced louvered fins for maximum heat transfer capability
- Louvered cabinet protects coil from fin damage
- Vertical air discharge sends hot air up and away from home and shrubbery
- Easy access to electrical panel, pre-wired for easy hook-up
- Angled service valves are positioned to allow easy access with low-loss fittings and are set for direct and straight line-set access to the home
- Bi-directional liquid line filter drier factory installed
- Discharge muffler for quiet operation
- Low pressure switch factory installed
- Integrated control with LED diagnostics and adjustable time (30/60/90 minutes) and temperature defrost control furnished
- Short-cycle protection
- The corrosion-resistant cabinet is built from strong, heavy-gauge pre-painted steel and has drainage holes to quickly remove standing water from the base pan
- Every heat pump is tested at the factory before shipment to ensure dependable performance
- AHRI Certified and ETL listed
- Charged for 15 feet of line-set

13 SEER
7.7 HSPF
1.5 to 5 Tons



Warranty
Compressor - 5 Year Limited
Parts - 5 Year Limited

Heat Pumps

4HP13L

Cooling/Heating Performance

Outdoor Unit Model No.	¹ Rated Air Capacity	SEER	EER	Heating Capacity		HSPF	Indoor Unit Model No.	Indoor Metering Device	AHRI Reference No.
				High	Low				
4HP13L18P-7	18,000	13.00	11.00	15,400	8,400	7.7	A*24E(1,2)*+TXV+TD	49L24	4718939
	18,000	13.00	11.00	15,400	8,400	7.7	A*30F(1,2)*+TXV+TD	49L24	4718940
	18,000	13.00	11.00	15,400	8,400	7.7	A*36G(1,2)*+TXV+TD	49L24	4718941
	18,000	13.00	11.00	15,400	8,400	7.7	AH24D(1,2)B+TXV+TD	49L24	4718942
	18,000	13.00	11.00	15,400	8,400	7.7	AH30F(1,2)B+TXV+TD	49L24	4718943
	18,000	13.00	11.00	15,400	8,400	7.7	AH36G(1,2)B+TXV+TD	49L24	4718944
	17,600	13.00	11.00	16,600	10,000	7.7	BCS3M18C****P+TXV	49L24	4626345
4HP13L24P-7	23,000	13.00	11.00	20,000	11,400	7.7	A*30F(1,2)*+TD	49L24	4718945
	23,000	13.00	11.00	20,000	11,400	7.7	A*36G(1,2)*+TD	49L24	4718946
	23,000	13.00	11.00	20,000	11,400	7.7	AH24D(1,2)B+TD	49L24	4718947
	23,000	13.00	11.00	20,000	11,400	7.7	AH30F(1,2)B+TD	49L24	4718948
	23,000	13.00	11.00	20,000	11,400	7.7	AH36G(1,2)B+TD	49L24	4718949
	23,000	13.00	11.00	21,400	13,000	7.7	BCS3M24C****P	49L24	4626347
4HP13L30P-7	29,000	13.00	11.00	25,400	15,400	7.7	A*36G(1,2)*+TD	49L24	5696603
	28,000	13.00	11.00	26,800	17,000	7.7	BCS3M30C****P	49L24	4626349
4HP13L36P-7	35,000	13.00	11.00	32,200	16,400	7.7	A*36G(1,2)*+TD	49L25	4718950
	35,000	13.00	11.00	32,200	16,400	7.7	A*42A(1,2)*+TD	49L25	4718951
	35,000	13.00	11.00	32,200	16,400	7.7	AH36G(1,2)B+TD	49L25	4718952
	34,600	13.00	11.00	33,000	18,000	7.7	BCS3M36C****P	49L25	4626351
4HP13L42P-7	41,000	13.00	11.00	38,000	23,400	7.7	A*48B(1,2)*+TD	49L25	4718953
	41,000	13.00	11.00	38,000	23,400	7.7	A*48D(1,2)*+TD	49L25	4718954
	41,000	13.00	11.00	38,000	23,400	7.7	AH48C(1,2)C+TD	49L25	4718955
	40,500	13.00	11.00	39,000	25,000	7.7	BCS3M42C****P	49L25	4626353
4HP13L48P-7	48,000	13.00	11.00	43,000	26,400	7.7	A*48D(1,2)*+TD	91M02	4718956
	48,000	13.00	11.00	43,000	26,400	7.7	AH48C(1,2)C+TD	91M02	4718957
	48,000	13.00	11.00	44,500	28,000	7.7	BCS3M48C****P	91M02	4626355
4HP13L60P-7	58,000	13.00	11.00	52,000	32,400	7.7	A*60G(1,2)*+TD	91M02	4718958
	58,000	13.00	11.00	52,000	32,400	7.7	AH60D(1,2)C+TD	91M02	4718968
	58,000	13.00	11.00	52,000	32,400	7.7	AH60D(1,2)D+TD	91M02	4718959
	57,000	13.00	11.00	55,000	34,000	7.7	BCS3M60C****P+TXV	91M02	4626357

¹ AHRI Certified to Standard 210/240.

NOTE - All ratings include the use of a blower time delay. All BCS3 air handlers have time delay capabilities. If a coil is matched with a furnace the furnace may require an optional time delay relay for field installation. See furnace or air handler specifications to determine if relay is needed.

NOTES - A* = All AU (uncased) and AC (cased) Aire-Flo coils.

+TXV = TXV required.

+TD = Time Delay required.

****P+TXV = Piston equipped models with optional TXV.

Heat Pumps

4HP13L

Sound Ratings

Model No.	Sound Rating dBA
4HP13L18P	76
4HP13L24P	76
4HP13L30P	76
4HP13L36P	76
4HP13L42P	80
4HP13L48P	80
4HP13L60P	80

Dimensions

Model No.	4HP13L18P	4HP13L24P	4HP13L30P	4HP13L36P
Cabinet Width (A) in	24-1/4"	24-1/4"	28-1/4"	28-1/4"
Cabinet Depth (B) in	24-1/4"	24-1/4"	28-1/4"	28-1/4"
Height (C) in	33-1/4"	33-1/4"	29-1/4"	37-1/4"

Model No.	4HP13L42P	4HP13L48P	4HP13L60P
Cabinet Width (A) in	28-1/4"	28-1/4"	28-1/4"
Cabinet Depth (B) in	28-1/4"	28-1/4"	28-1/4"
Height (C) in	43-1/4"	33-1/4"	37-1/4"

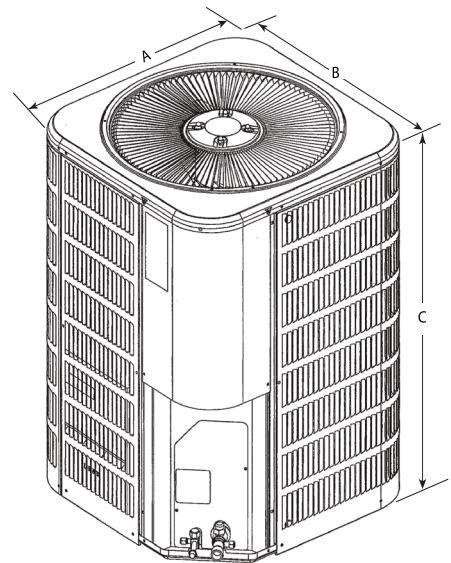

Revisions

Sections	Description of Change
Dimensions	Updated



1.800.982.2333
www.aireflo-hvac.com

