



Indoor Coils AH

PRODUCT SPECIFICATIONS

- R-410A Refrigerant Ready
- External flator assembly for easy piston changes and fast screw-on TXV installation
- Heavy gauge embossed galvanized cabinets are fully lined with 5/8" foil faced insulation
- Filler strip furnished for coil to furnace matching
- Non-captive panels are removable for easy servicing or cleaning
- Interlocking door assemblies and snug line seal grommets minimize air leakage
- Rifled copper tubing
- Patented lance fin design
- Dual condensate drain connections on both sides of coil for installation flexibility
- Hydrotec™ low water retention drain pan with Microban® antimicrobial additive
- UV resistant drain pans constructed of high temperature engineering polymer
- Refrigerant connections on top of coil
- Coils are individually tested, pressurized and sealed at the factory
- ISO 9002 registered manufacturing quality system
- UL Listed

**Horizontal
2 to 5 Tons**



**Warranty
5 Year Limited**

Indoor Coils

AH

Model Number Identification

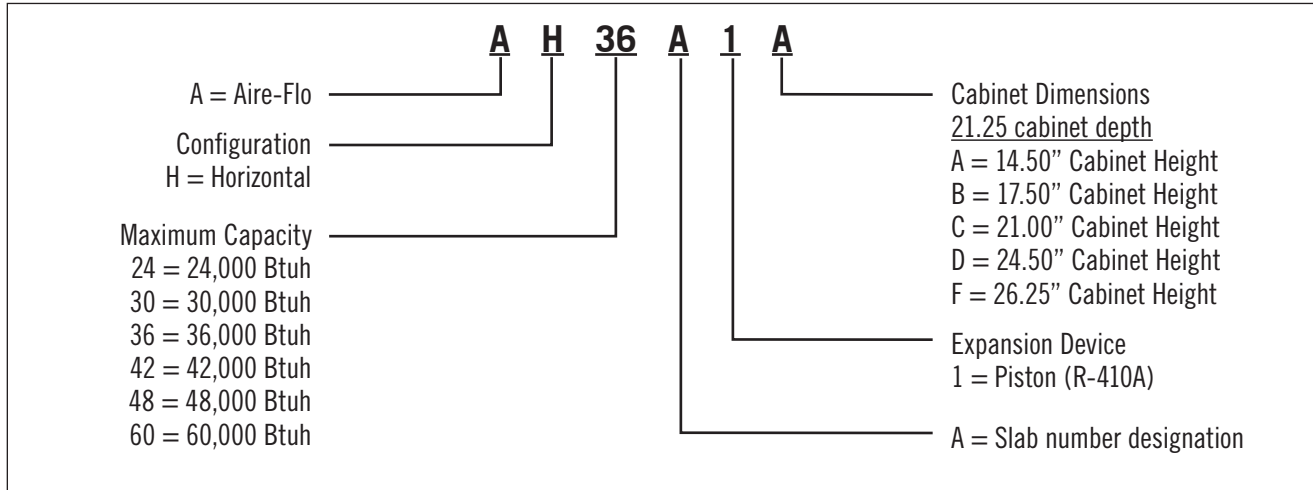

Specifications

General Data	Model No.	AH24D1B	AH30F1B	AH36G1B	AH48A1B AH48A1C AH48C1C	AH60D1C AH60D1D
		Nominal size – tons	2	2.5	3	4
Line Connections	Suction o.d. – in. sweat	3/4	3/4	3/4	7/8	7/8
	Liquid o.d. – in. sweat	3/8	3/8	3/8	3/8	3/8
	Condensate drain (fpt) – in.	(2) 3/4	(2) 3/4	(2) 3/4	(2) 3/4	(2) 3/4
Air Data	CFM	800	1000	1200	1600	2000
	Face Velocity (fpm)	200	315	337	343	343
	*Air Pressure Drop (in. w.g.)	0.15	0.27	0.29	0.30	0.40
Weight – lbs.		43	46	50	53 (1B) 57 (1C)	60

*Air pressure drop data is under dry conditions. For wet coil conversion at AHRI conditions, multiply by 1.3.

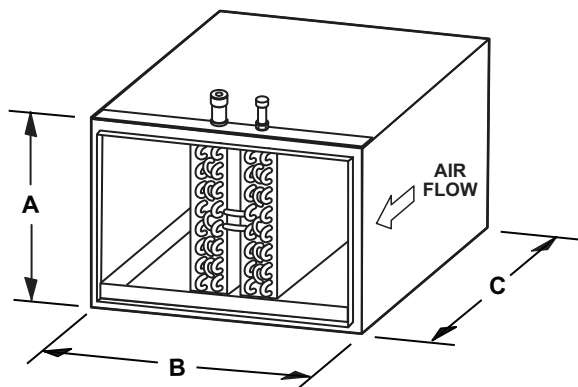

Dimensions

Model No.	Height	Width	Depth	Supply Air Opening		Return Air Opening	
	A	B	C	Height	Width	Height	Width
AH24D1B	17.50	21.00	26.50	16	19.5	16.5	20
AH30F1B	17.50	21.00	21.50	16	19.5	16.5	20
AH36G1B	17.50	21.00	21.50	16	19.5	16.5	20
AH48A1B	17.50	21.00	26.50	16	19.5	16.5	20
AH48A1C	21.00	21.00	21.50	19.5	19.5	20	20
AH48C1C	21.00	21.00	26.50	19.5	19.5	20	20
AH60D1C	21.00	21.00	26.50	19.5	19.5	20	20
AH60D1D	24.50	21.00	26.50	23	19.5	23.5	20



1.800.982.2333
www.aireflo-hvac.com