

**ELS SERIES UNITS**

The ELS units are designed for light commercial applications, with a remotely located blower-coil unit or a furnace with an add-on evaporator coil. Capacities for the series are 6, 7-1/2, 10, 12.5, 15 and 20 tons (21, 26, 35, 44, 53, and 70 kW). ELS072, ELS090 and ELS120S4S models have one dual-speed scroll compressor. ELS120S4D, ELS150S4D, ELS180S4D and ELS240S4D models have two single-speed scroll compressors. ELS units match with the ELA blower-coil units. All ELS units are three phase and use HFC-410A refrigerant.

This manual covers ELS072S4S, ELS090S4S, ELS120S4S, ELS120S4D, ELS150S4D, ELS180S4D and ELS240S4D units. It is divided into sections which discuss the major components, refrigerant system, charging procedure, maintenance and operation sequence.

Information in this manual is intended for qualified service technicians only. All specifications are subject to change. Procedures in this manual are presented as a recommendation only and do not supersede or replace local or state codes.



**⚠ WARNING**

Improper installation, adjustment, alteration, service or maintenance can cause property damage, personal injury or loss of life. Installation and service must be performed by a licensed professional HVAC installer or equivalent, service agency, or the gas supplier.

**⚠ IMPORTANT**

The Clean Air Act of 1990 bans the intentional venting of refrigerant (CFCs, HCFCs and HFCs) as of July 1, 1992. Approved methods of recovery, recycling or reclaiming must be followed. Fines and/or incarceration may be levied for noncompliance.

**⚠ WARNING**

 Electric shock hazard! - Disconnect all power supplies before servicing.  
Replace all parts and panels before operating.  
Failure to do so can result in death or electrical shock.

**⚠ CAUTION**

As with any mechanical equipment, contact with sharp sheet metal edges can result in personal injury. Take care while handling this equipment and wear gloves and protective clothing.

**Table of Contents**

Unit Plumbing Parts Arrangement .....	5
Model Number Identification .....	10
Unit Control Box Components Arrangement .....	11
I-UNIT COMPONENTS .....	12
A-CONTROL BOX COMPONENTS .....	12
B-COOLING COMPONENTS.....	12
II- REFRIGERANT SYSTEM .....	13
A-Plumbing .....	13
B-Service Valves .....	14
III-START-UP.....	15
IV-CHARGING.....	16
A-Leak Testing.....	16
B-Evacuating the System .....	17
C-Charging .....	18
V-MAINTENANCE .....	23
VI-Wiring Diagram and Sequence of Operation .....	24

## SPECIFICATIONS - 6 - 7.5 TON

General Data		Model No.	ELS072S4S	ELS090S4S
		<b>Nominal Size - Tons</b>	<b>6</b>	<b>7.5</b>
<b>Connections (sweat)</b>	Liquid line - in. (o.d)		(1) 3/8	(1) 5/8
	Suction line - in. (o.d)		(1) 1-1/8	(1) 1-1/8
<b>Refrigerant (R-410A)</b>	Factory Charge		R-410A holding charge (2 lbs. per stage)	
	<sup>1</sup> Field charge (25 ft. line set)		18 lbs. 0 oz.	20 lbs. 0 oz.
<b>Compressor</b>			(1) Two-Stage Scroll	(1) Two-Stage Scroll
<b>Condenser Coil</b>	Net face area - sq. ft.	Outer coil	29.3	29.3
		Inner coil	14.2	28.4
	Tube diameter - in. & no. of rows		3/8 - 1.5	3/8 - 2
		Fins per inch	20	20
<b>Condenser Fan(s)</b>	Diameter - in. & no. of blades		(1) 24 - 3	(1) 24 - 4
	Motor hp		(1) 1/3	(1) 1/2
		Total air volume - cfm	4700	5600
		Rpm	1075	1075
		Watts	400	580

## ELECTRICAL DATA

Line voltage data - 60 Hz - 3 phase		208/230V	460V	575V	208/230V	460V	575V
<sup>2</sup> Maximum Overcurrent Protection (amps)		40	15	15	60	25	20
<sup>3</sup> Minimum circuit ampacity		24	12	9	37	17	13
<b>Compressor</b>	No. of Compressors	1	1	1	1	1	1
	Rated load amps	17.6	8.5	6.3	26.9	12	9
	Locked rotor amps	136	66	55	165	94	65
<b>Condenser Fan Motor (1 phase)</b>	No. of motors	1	1	1	1	1	1
	Full load amps	1.7	0.8	1	3	1.5	1.2
		Locked rotor amps	4.3	2.4	1.9	6	2.9

NOTE - Extremes of operating range are plus and minus 10% of line voltage.

<sup>1</sup> Field provided charge with 25 ft. line set. Refer to the Lennox Refrigerant Piping Manual to determine refrigerant charge required with longer length refrigerant lines.

<sup>2</sup> HACR type circuit breaker or fuse.

<sup>3</sup> Refer to National or Canadian Electrical Code manual to determine wire, fuse and disconnect size requirements.

## SPECIFICATIONS - 10 TON

General Data		Model No.	ELS120S4S	ELS120S4D
		<b>Nominal Size - Tons</b>	<b>10</b>	<b>10</b>
<b>Connections (sweat)</b>	Liquid line - in. (o.d)		(1) 5/8	(2) 3/8
	Suction line - in. (o.d)		(1) 1-1/8	(2) 1-1/8
<b>Refrigerant (R-410A)</b>	Factory Charge		R-410A holding charge (2 lbs. per stage)	
	<sup>1</sup> Field charge (25 ft. line set)	Circuit 1	32 lbs. 0 oz.	12 lbs. 0 oz.
		Circuit 2	---	12 lbs. 0 oz.
<b>Compressor</b>			(1) Two-Stage Scroll	(2) Single-Stage Scroll
<b>Condenser Coil</b>	Net face area - sq. ft.	Outer coil	29.3	29.3
		Inner coil	28.4	28.4
	Tube diameter - in. & no. of rows		3/8 - 2	3/8 - 2
		Fins per inch	20	20
<b>Condenser Fan(s)</b>	Diameter - in. & no. of blades		(2) 24 - 3	(2) 24 - 3
	Motor hp		(2) 1/3	(2) 1/3
		Total air volume - cfm	8300	8300
		Rpm	1075	1075
		Watts	830	830

## ELECTRICAL DATA

Line voltage data - 60 Hz - 3 phase		208/230V	460V	575V	208/230V	460V	575V
<sup>2</sup> Maximum Overcurrent Protection (amps)		80	30	25	45	20	15
<sup>3</sup> Minimum circuit ampacity		47	21	16	33	16	13
<b>Compressor</b>	No. of Compressors	1	1	1	2	2	2
	Rated load amps (total)	34.6	14.8	11.1	13.2 (26.4)	6.3 (12.6)	4.9 (9.8)
	Locked rotor amps (total)	240	130	94	93 (186)	60 (120)	41 (82)
<b>Condenser Fan Motor (1 phase)</b>	No. of motors	2	2	2	2	2	2
	Full load amps (total)	1.7 (3.4)	0.8 (1.6)	1 (2)	1.7 (3.4)	0.8 (1.6)	1 (2)
		Locked rotor amps (total)	4.3 (8.6)	2.4 (4.8)	1.9 (3.8)	4.3 (8.6)	2.4 (4.8)

NOTE - Extremes of operating range are plus and minus 10% of line voltage.

<sup>1</sup> Field provided charge with 25 ft. line set. Refer to the Lennox Refrigerant Piping Manual to determine refrigerant charge required with longer length refrigerant lines.

<sup>2</sup> HACR type circuit breaker or fuse.

<sup>3</sup> Refer to National or Canadian Electrical Code manual to determine wire, fuse and disconnect size requirements.

**SPECIFICATIONS - 12.5 - 20 TON**

General Data		Model No.	ELS150S4D	ELS180S4D	ELS240S4D
Nominal Size - Tons			12.5	15	20
Connections (sweat)	Liquid line - in. (o.d)		(2) 3/8	(2) 5/8	(2) 5/8
	Suction line - in. (o.d)		(2) 1-1/8	(2) 1-1/8	(2) 1-1/8
Refrigerant (R-410A)	Factory Charge		R-410A holding charge (2 lbs. per stage)		
	<sup>1</sup> Field charge (25 ft. line set)	Circuit 1	15 lbs. 0 oz.	24 lbs. 0 oz.	22 lbs. 4 oz.
		Circuit 2	15 lbs. 0 oz.	24 lbs. 0 oz.	23 lbs. 3 oz.
Compressor			(2) Single-Stage Scroll	(2) Single-Stage Scroll	(2) Single-Stage Scroll
Condenser Coil	Net face area - sq. ft. Outer coil		34.2	58.7	58.7
	Inner coil		33.3	57.7	57.7
	Tube diameter - in. & no. of rows		3/8 - 2	3/8 - 2	3/8 - 2
	Fins per inch		20	20	20
Condenser Fan(s)	Diameter - in. & no. of blades		(2) 24 - 4	(4) 24 - 3	(4) 24 - 3
	Motor hp		(2) 1/2	(4) 1/3	(4) 1/3
	Total air volume - cfm		10,300	16,600	16,600
	Rpm		1075	1075	1075
	Watts		1130	1660	1660

**ELECTRICAL DATA**

Line voltage data - 60 hz - 3 phase		208/230V	460V	575V	208/230V	460V	575V	208/230V	460V	575V
<sup>2</sup> Maximum Overcurrent Protection (amps)		60	25	25	80	40	30	90	50	40
<sup>3</sup> Minimum circuit ampacity		50	21	20	63	31	25	70	36	30
Compressor	No. of Compressors	2	2	2	2	2	2	2	2	2
	Rated load amps (total)	19.6 (39.2)	8.2 (16.4)	6.6 (13.2)	25 (50)	12.2 (24.4)	9 (18)	28.2 (56.4)	14.7 (29.4)	11.3 (22.6)
	Locked rotor amps (total)	136 (272)	66 (132)	55 (110)	164 (328)	100 (200)	78 (156)	240 (480)	130 (260)	93.7 (187.4)
Condenser Fan Motor (1 phase)	No. of motors	2	2	2	4	4	4	4	4	4
	Full load amps (total)	3 (6)	1.5 (3)	1.2 (2.4)	1.7 (6.8)	0.8 (3.2)	1 (4)	1.7 (6.8)	0.8 (3.2)	1 (4)
	Locked rotor amps (total)	6 (12)	3 (6)	2.9 (5.8)	4.3 (17.2)	2.4 (9.6)	1.9 (7.6)	4.3 (17.2)	2.4 (9.6)	1.9 (7.6)

NOTE - Extremes of operating range are plus and minus 10% of line voltage.

<sup>1</sup> Field provided charge with 25 ft. line set. Refer to the Lennox Refrigerant Piping Manual to determine refrigerant charge required with longer length refrigerant lines.

<sup>2</sup> HACR type circuit breaker or fuse.

<sup>3</sup> Refer to National or Canadian Electrical Code manual to determine wire, fuse and disconnect size requirements.

**WEIGHT DATA**

Model No.	Net		Shipping	
	lbs.	kg	lbs.	kg
072S	318	144	338	153
090S	345	157	365	166
120S	452	205	477	216
120D	480	218	505	229
150S	535	243	560	254
180S	775	352	800	363
240S	832	377	857	389

**OPTIONS / ACCESSORIES**

**COMBINED COIL/HAIL GUARDS**

T2GARD20L-1	40	18	45	20
T2GARD20M-1	45	20	50	23
T2GARD21M-1	45	20	50	23
T2GARD20N-1-	90	41	100	45

OPTIONS / ACCESSORIES

Item		Catalog No.	ELS 072 S4S	ELS 090 S4S	ELS 120 S4S	ELS 120 S4D	ELS 150 S4D	ELS 180 S4D	ELS 240 S4D
CABINET									
Combined Coil/Hail Guards	T2GARD51L-1	13T29	X	X					
	T2GARD51M11	13T30			X	X			
	T2GARD51M21	13T32					X		
	T2GARD51N-1	13T37						X	X
Corrosion Protection	Factory		O	O	O	O	O	O	O
CONTROLS									
BACnet® Module	A0CTRL31LS1	17A08	X	X	X	X	X	X	X
BACnet® Sensor with Display	K0SNSR01FF1	97W23	X	X	X	X	X	X	X
BACnet® Sensor without Display	K0SNSR00FF1	97W24	X	X	X	X	X	X	X
Network Thermostat Control (NTC)	C0CTRL07AE1L	17M10	X	X	X	X	X	X	X
NTC Enclosure Kit (required with NTC Controller)	A0CTRL32LS1	16H99	X	X	X	X	X	X	X
L Connection® Building Automation System		- - -	X	X	X	X	X	X	X
Low Ambient Control (0°F)	A2CWKT01LM1-	16F18	X	X					
	A2CWKT04M-1-	16F26			X				
	A2CWKT02M-1-	16F24				X	X		
	A2CWKT03N-1-	16F25						X	X
ELECTRICAL									
GFI Service Outlets	15 amp non-powered, field-wired (208/230V, 460V only) LTAGFIK10/15/15	74M70	X	X	X	X	X	X	X
	20 amp non-powered, field-wired (575V only) C1GFIC120FF1	67E01	X	X	X	X	X	X	X
INDOOR AIR QUALITY									
Sensor - Wall-mount, off-white plastic cover with LCD display	C0SNSR50AE1L	77N39	X	X	X	X	X	X	X
Sensor - Wall-mount, off-white plastic cover, no display	C0SNSR52AE1L	87N53	X	X	X	X	X	X	X
Sensor - Black plastic case with LCD display, rated for plenum mounting	C0SNSR51AE1L	87N52	X	X	X	X	X	X	X
Sensor - Wall-mount, black plastic case, no display, rated for plenum mounting	C0SNSR53AE1L	87N54	X	X	X	X	X	X	X
CO <sub>2</sub> Sensor Duct Mounting Kit	C0MISC19AE1-	85L43	X	X	X	X	X	X	X
Aspiration Box - for duct mounting non-plenum rated CO <sub>2</sub> sensor (77N39)	C0MISC16AE1-	90N43	X	X	X	X	X	X	X

NOTE - The catalog and model numbers that appear here are for ordering field installed accessories only.

O - Factory Installed with extended lead time.

X - Field Installed

# Unit Plumbing Parts Arrangement

ELS072S4S

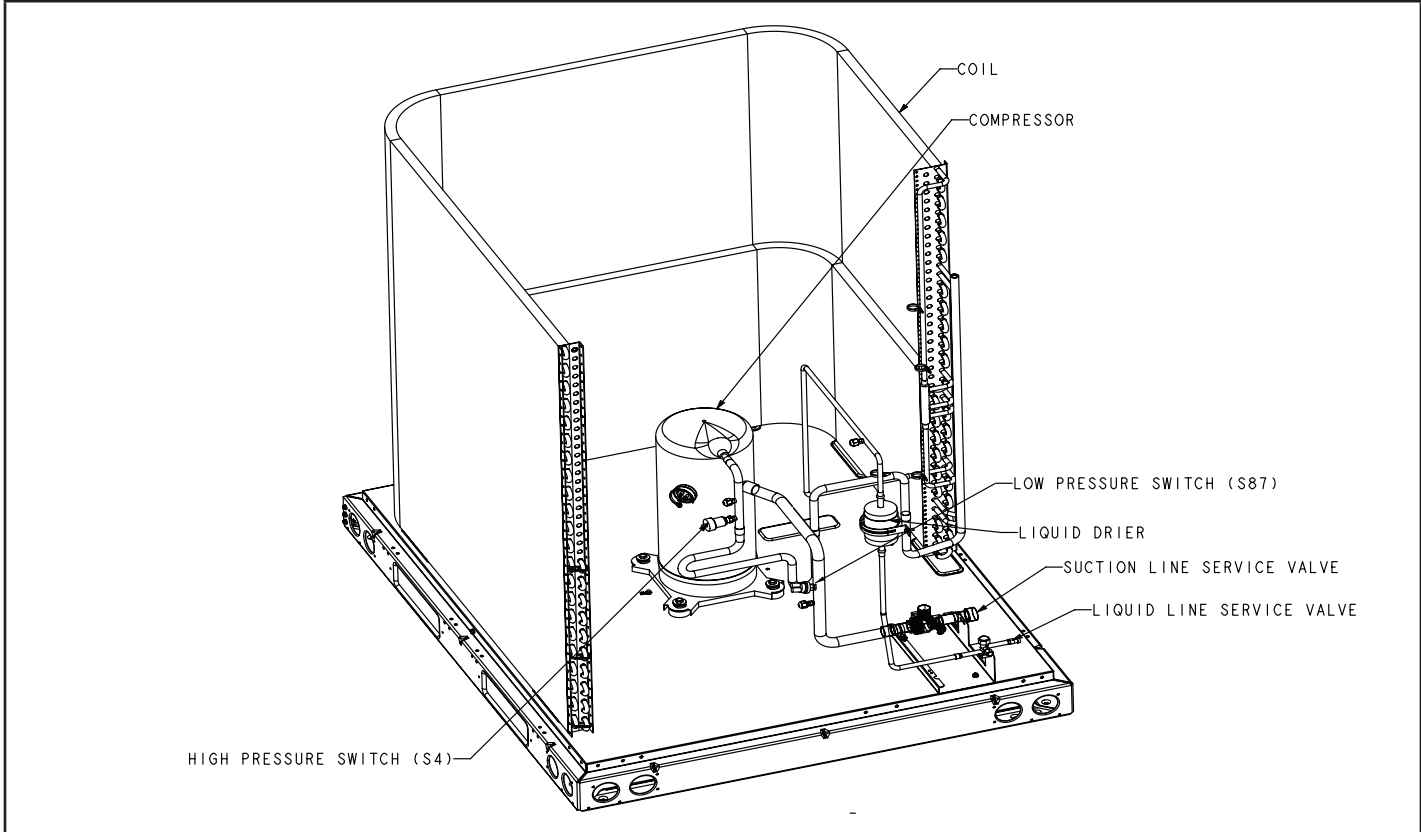

ELS090S4S

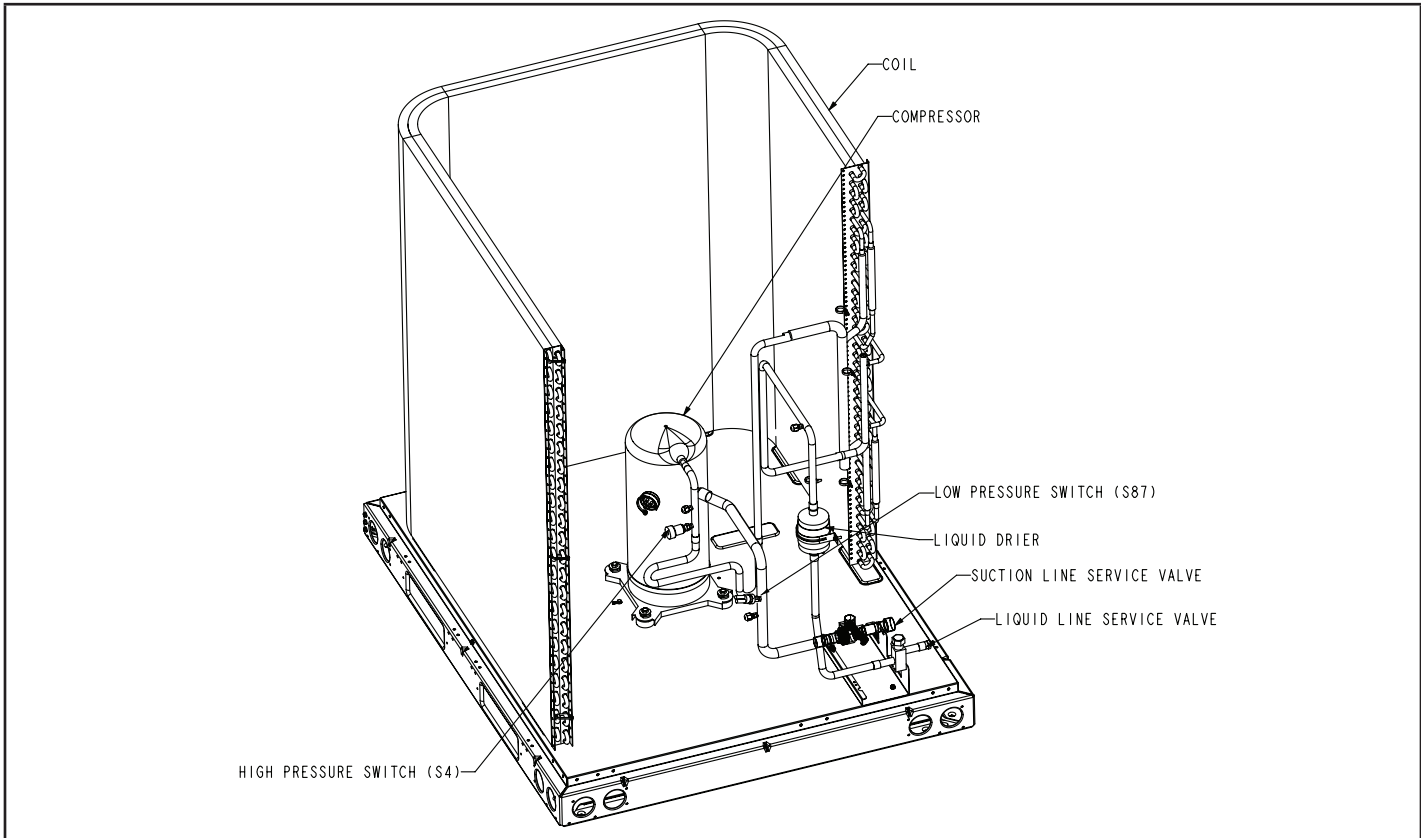

ELS120S4S

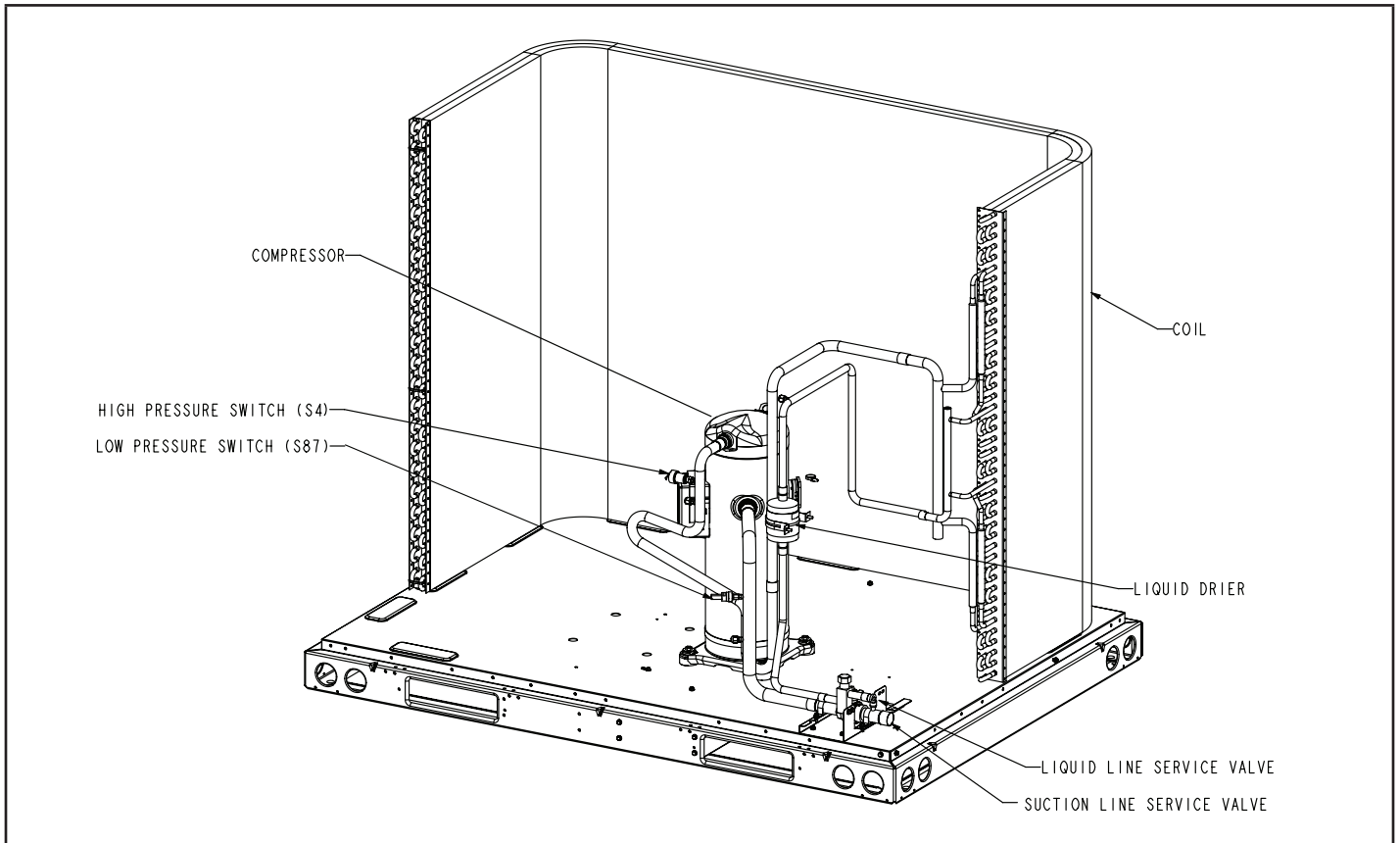

ELS120S4D – STAGE 2

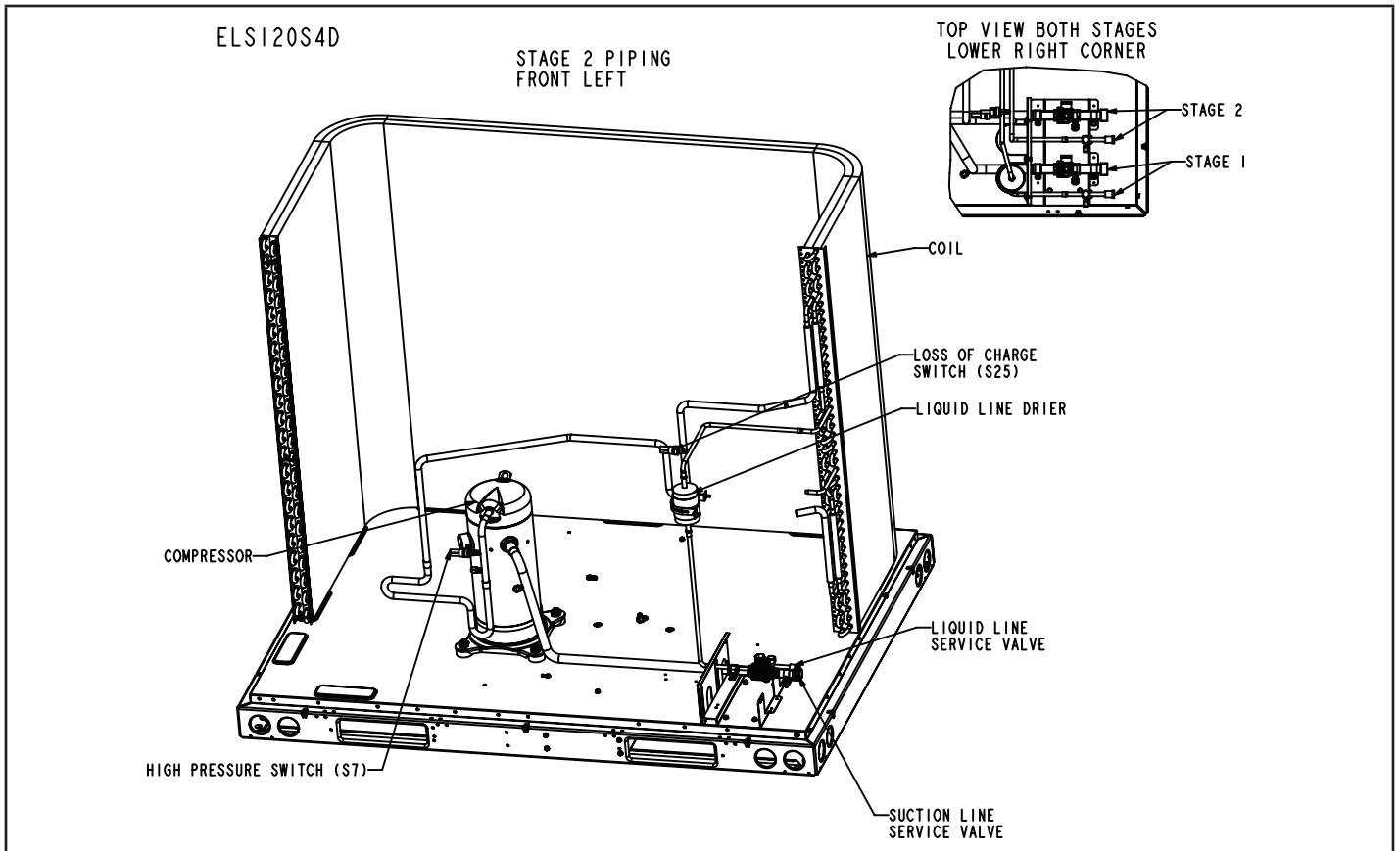

## ELS120S4D – STAGE 1

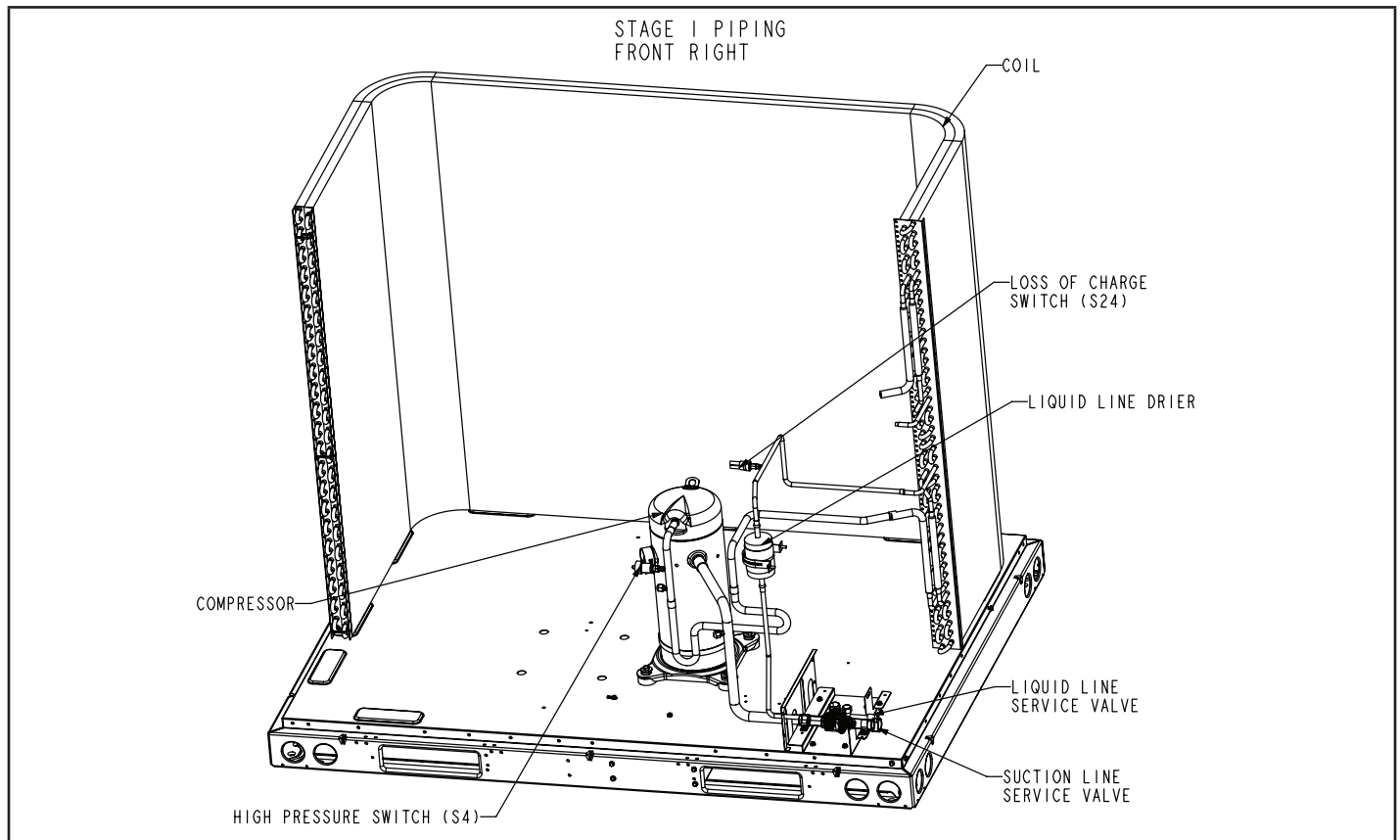

## ELS150S4D – STAGE 2

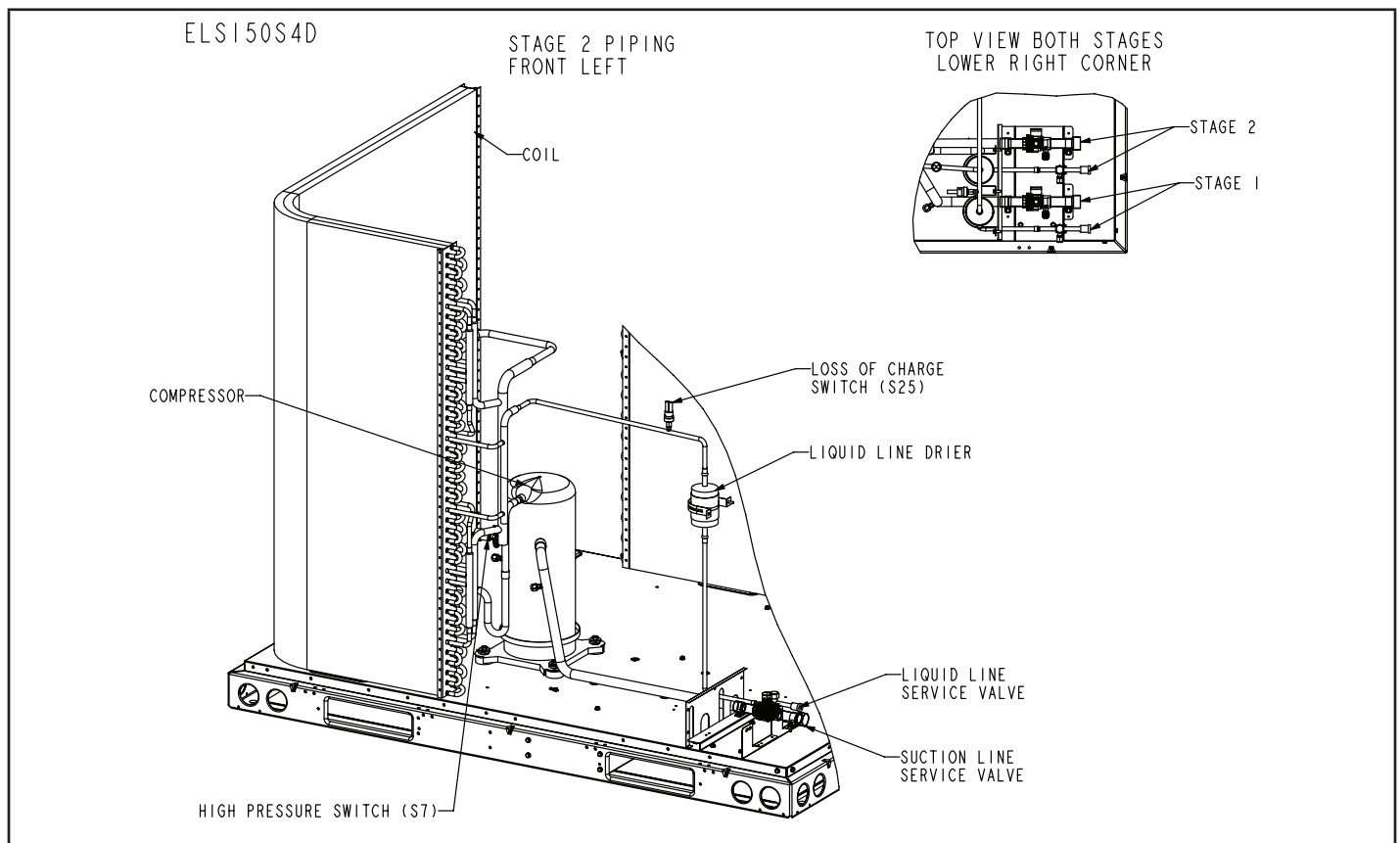

**ELS150S4D – STAGE 1**

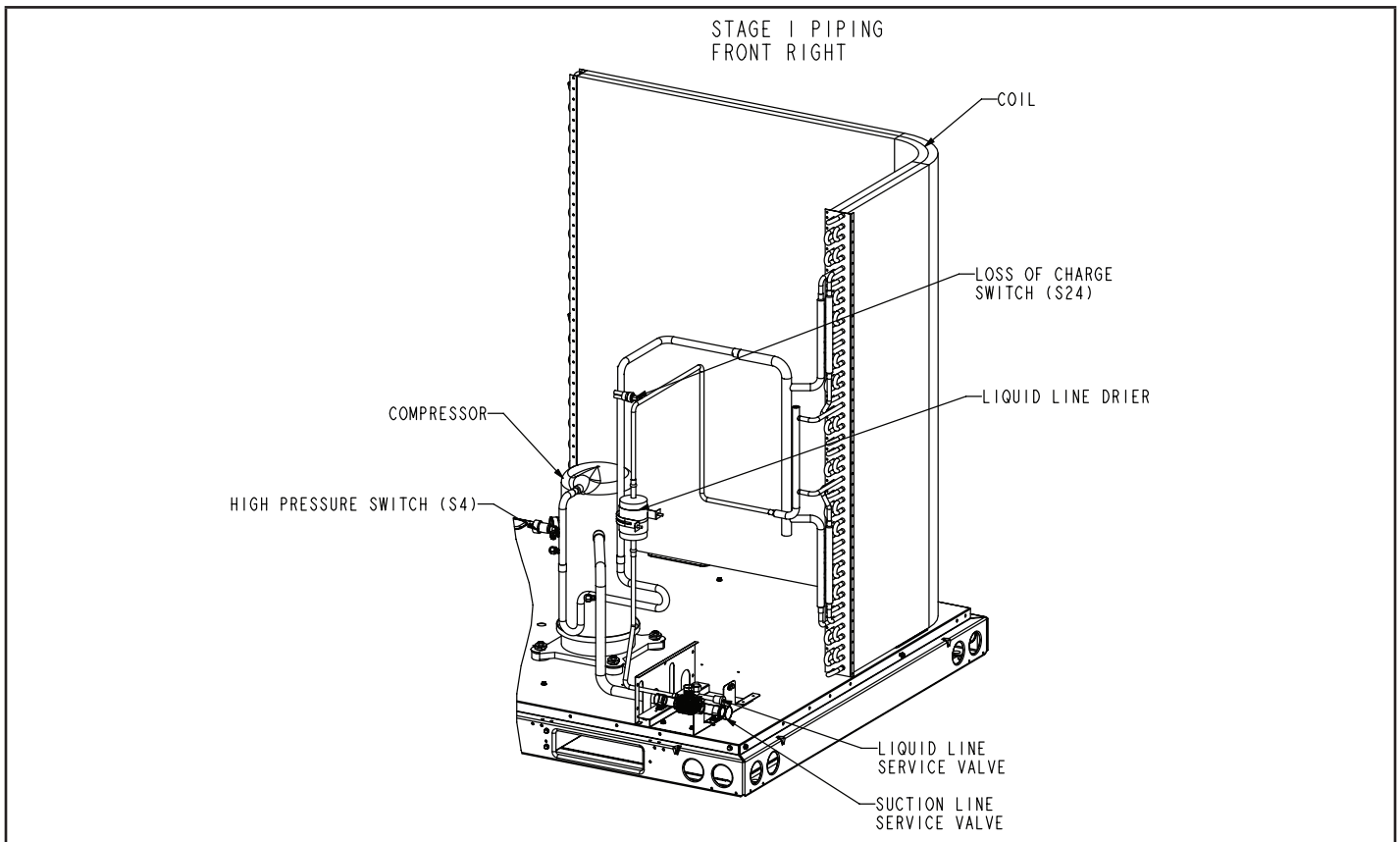

**ELS180S4D – STAGE 2**

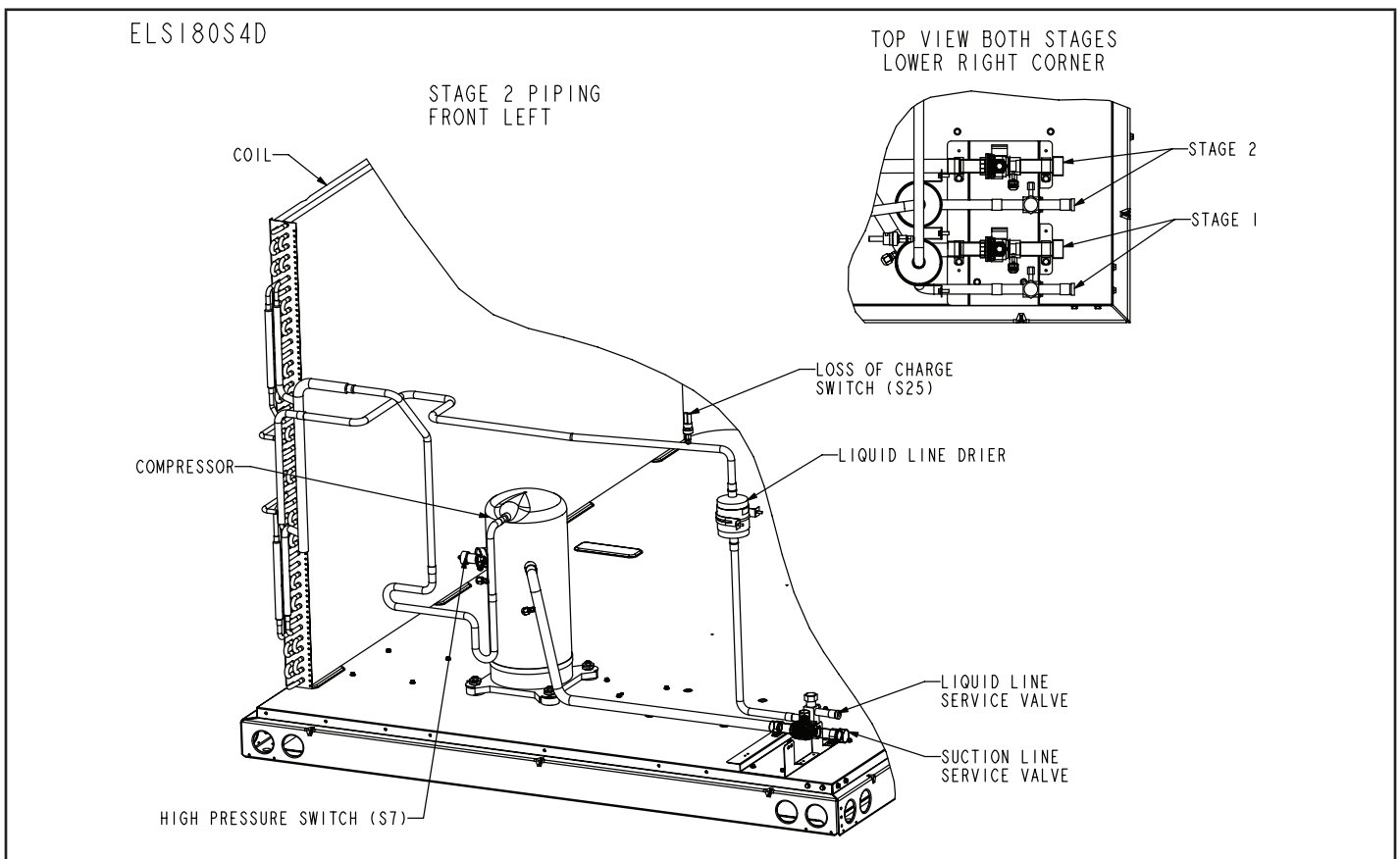



**ELS180S4D – STAGE 1**

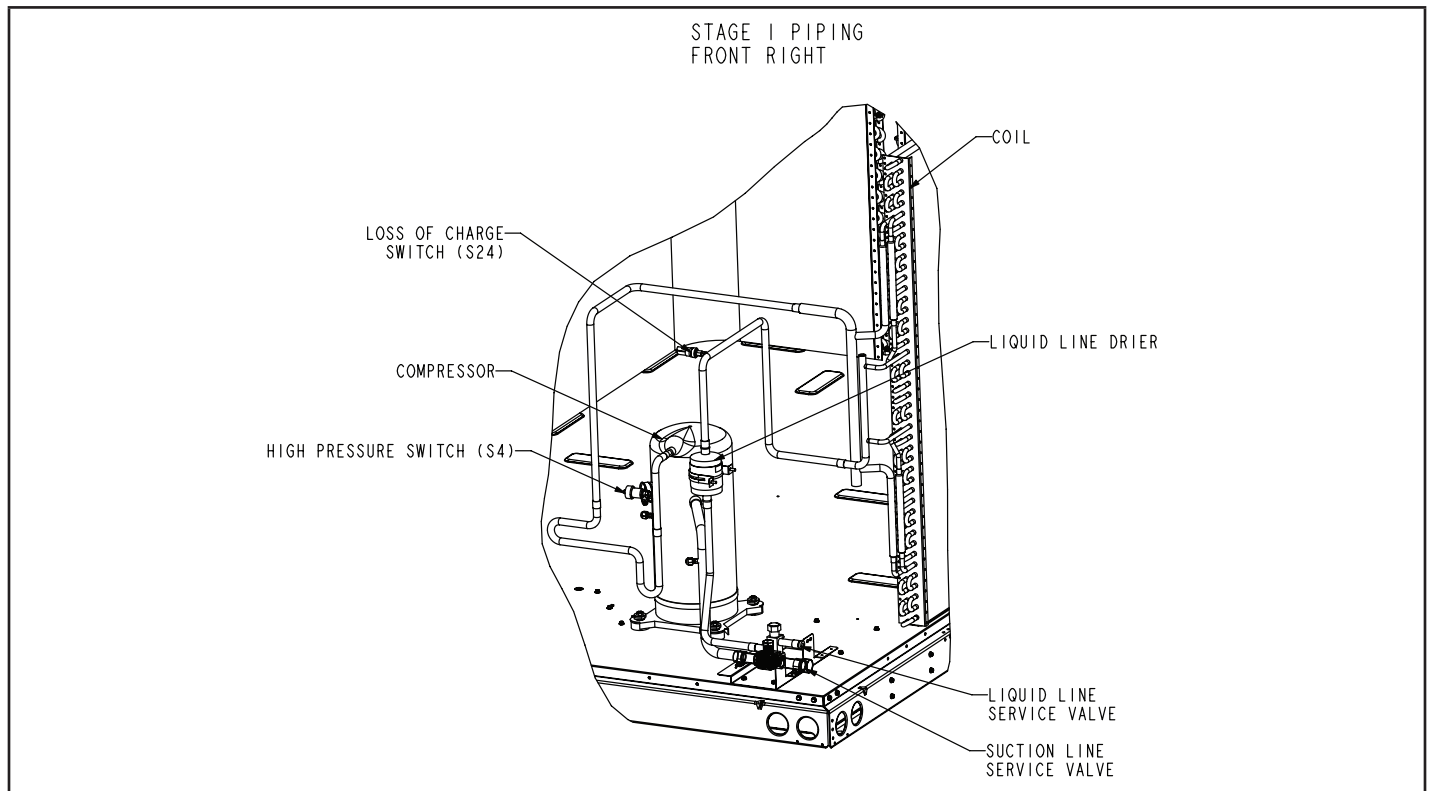

**ELS240S4D – STAGE 2**

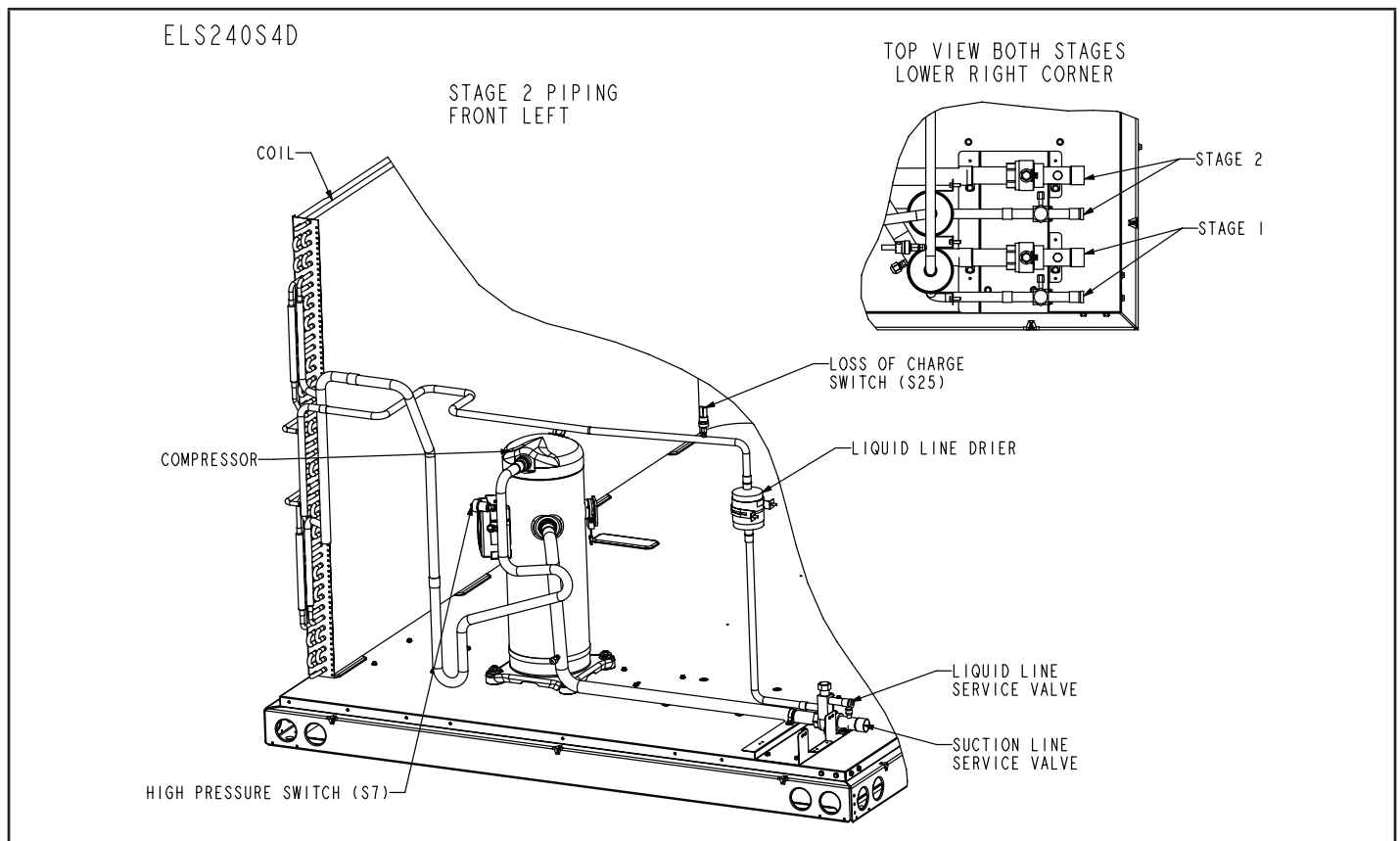

**ELS240S4D – STAGE 1**

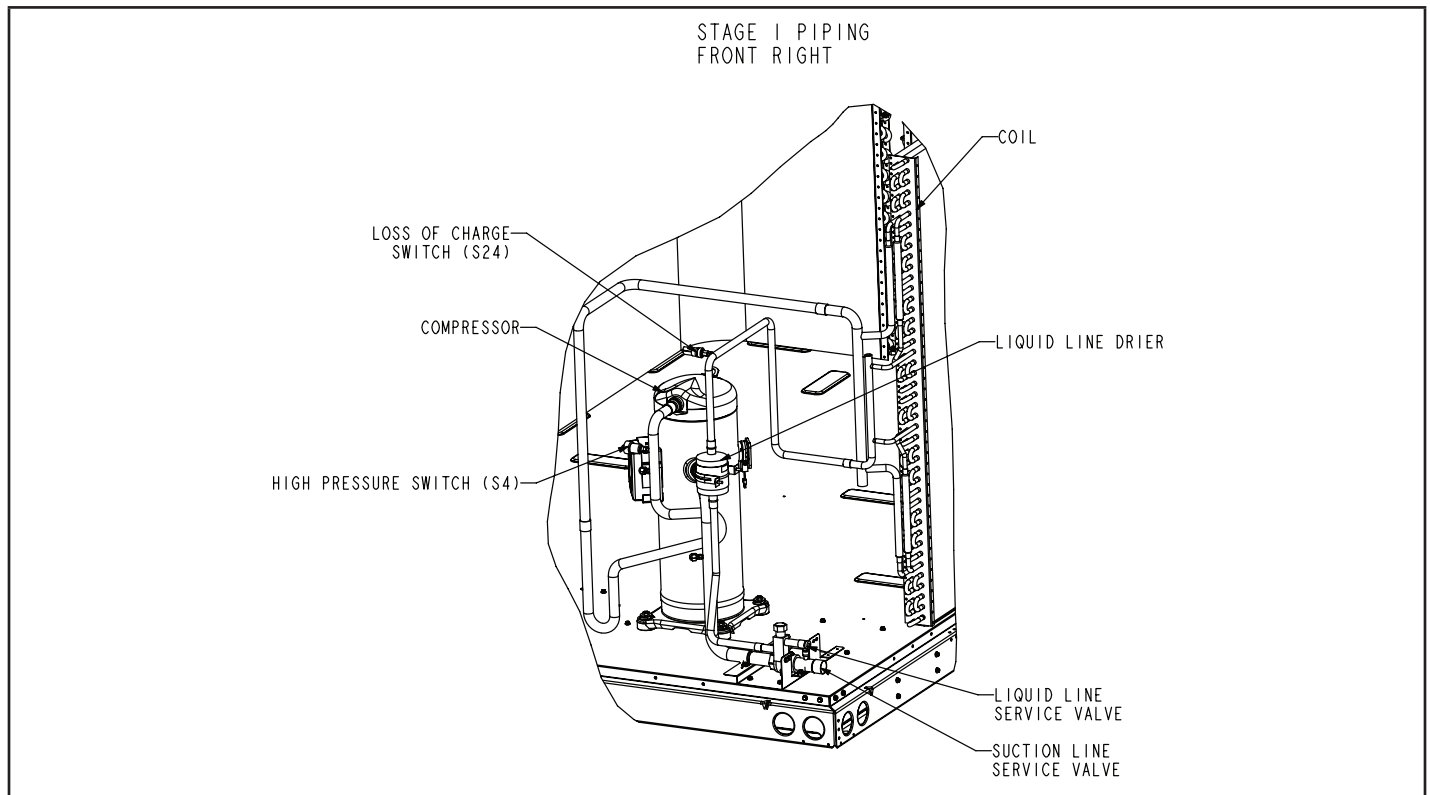

**Model Number Identification**

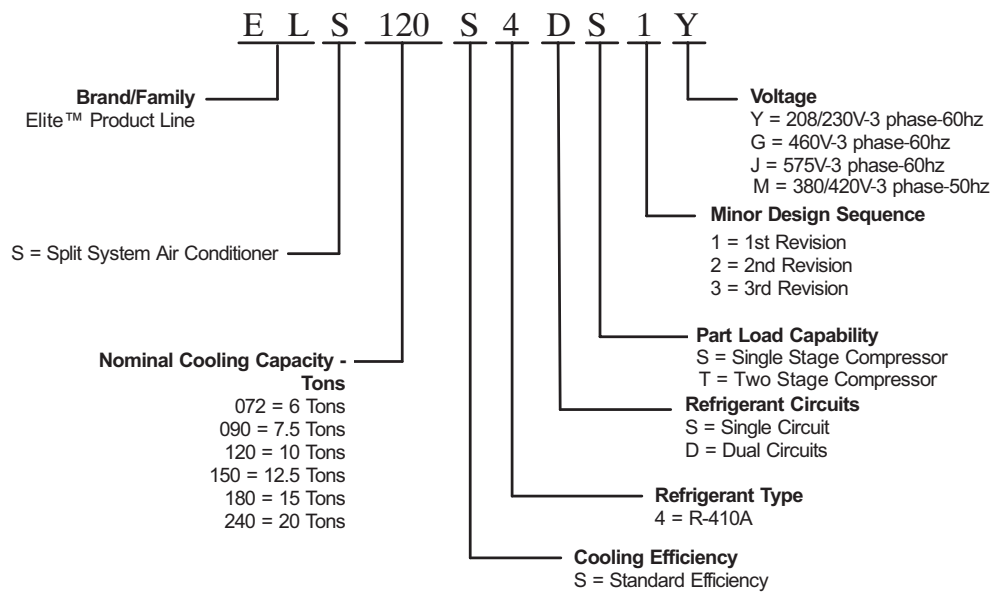

# Unit Control Box Components Arrangement

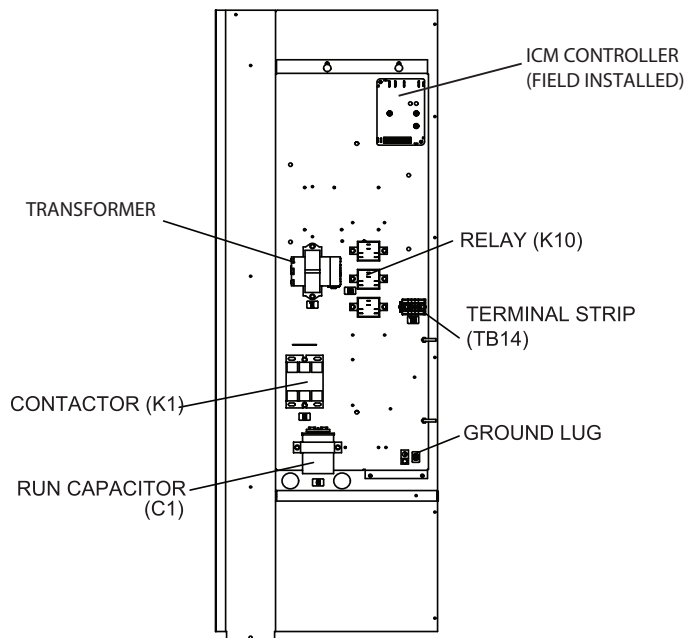

ELS072/090S

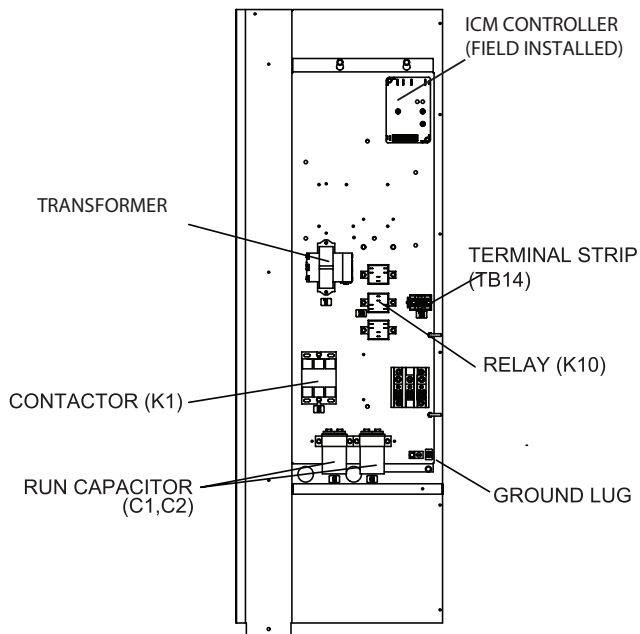

ELS120S

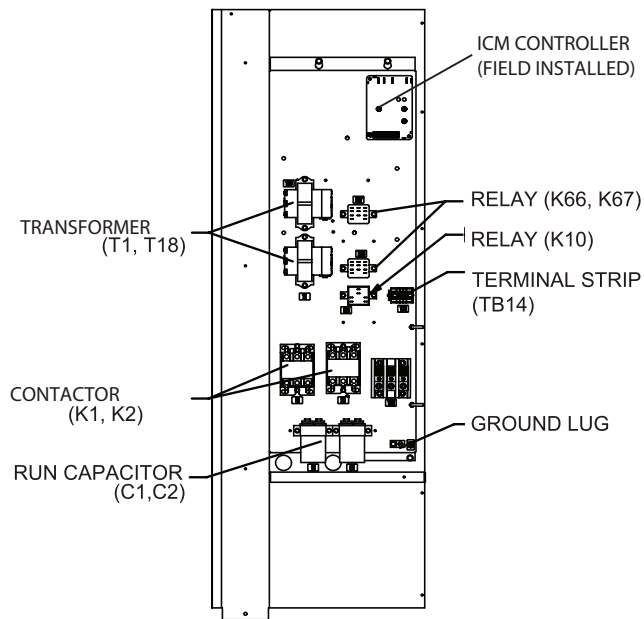

ELS120D/ELS150D

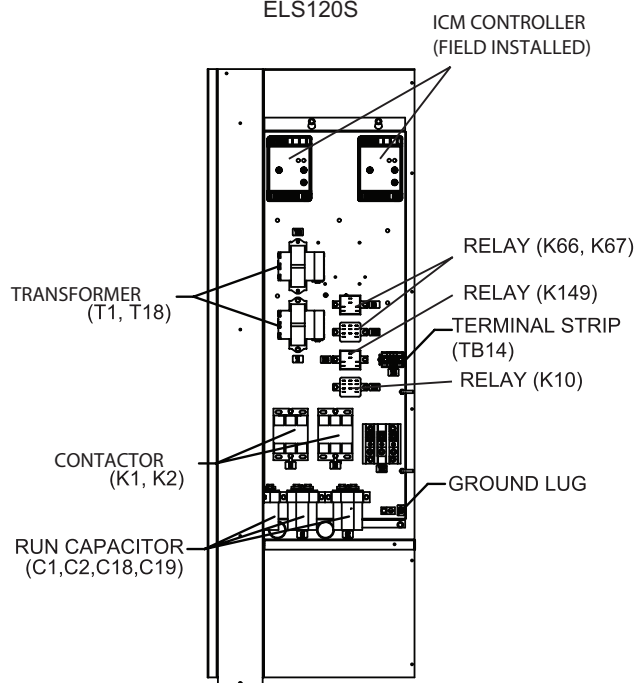

ELS180D / ELS240D

## I-UNIT COMPONENTS

The ELS parts arrangements are shown on pages 5 - 10 and control boxes on page 11.

<b>⚠ WARNING</b>	
<b>ELECTROSTATIC DISCHARGE (ESD)</b> Precautions and Procedures	Electrostatic discharge can affect electronic components. Take care during unit installation and service to protect the unit's electronic controls. Precautions will help to avoid control exposure to electrostatic discharge by putting the unit, the control and the technician at the same electrostatic potential. Touch hand and all tools on an unpainted unit surface before performing any service procedure to neutralize electrostatic charge.

## A-CONTROL BOX COMPONENTS

### 1 - Transformer T1 & T18

All ELS models use a single line voltage to 24VAC transformer mounted in the control box. Transformer T1 supplies power to control circuits in the ELS unit. The transformer is rated at 70VA and is protected by a 3.5 amp circuit breaker (CB8). CB8 is internal to the transformer. The 208/230 (Y) voltage transformers use two primary voltage taps as shown in figure 1, while 460 (G) and 575 (J) voltage transformers use a single primary voltage tap. T18 is identical to T1 used in ELS120, 150, 180 and 240 and is protected by internal circuit breaker CB18.

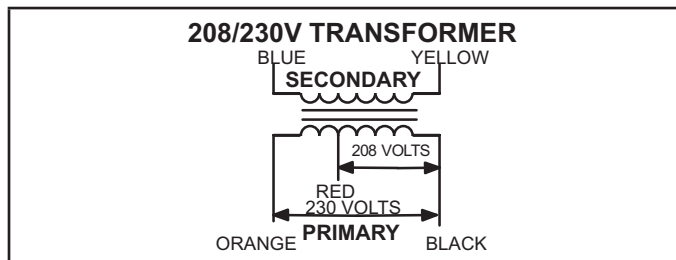

FIGURE 1

**NOTE** – 208 volt units are field wired with the red wire connected to control transformer. 230 volt units are factory wired with the orange wire connected to control transformer primary.

### 2 - Terminal Strip TB14 & TB2

Terminal strip TB14 used in all units distributes 24V power and common from the transformer T18 to the control box components. Terminal block TB2 used in the 120, 150, 180 and 240 units, distributes line voltage to line voltage components.

### 3 - Condenser Fan Capacitors C1, C2, C18, C19

All ELS units use single-phase condenser fan motors. Motors are equipped with a fan run capacitor to maximize motor efficiency. Condenser fan capacitors C1, C2, C18 and C19 assist in the start up of condenser fan motors B4, B5, B21 and B22. Capacitor ratings will be on condenser fan motor nameplate.

### 4 - Compressor Contactor K1 (all units) K2 (120S4D, 150, 180, 240)

All compressor contactors are three-pole double-break contactors with auxiliary switch with a 24V coil. In ELS072, 090 and 120S4S, K1 energizes compressor B1. In ELS120S4D, 150, 180 and 240 units, K1 and K2 energize compressors B1 and B2.

### 5 - Condenser Fan Relay K10 (all units) K149 (180, 240)

Condenser fan relays K10 and K149 are DPDT with a 24V coil. In all units K10 energizes condenser fan B4 (fan 1) in response to thermostat demand. In the ELS120S4D, 150, 180 and 240, K10 also energizes condenser fan B5 (fan 2) In the ELS180 and 240 K149 energizes condenser fans B21 (fan 3) and B22 (fan 4) in response to thermostat demand.

### 6 - Cooling Relays K66 (120S4D, 150, 180, 240) & K67 (all units)

Cooling relays K66 and K67 are N.O. DPDT relays. K66 is energized from "Y1" (1st stage cool), which in turn energizes contactor K2. K67 is energized by "Y2" (2nd stage cool), which in turn energizes contactor K1. This sequence is the start up of compressors B1 and B2.

## B-COOLING COMPONENTS

<b>⚠ WARNING</b>	
Refrigerant can be harmful if it is inhaled. Refrigerant must be used and recovered responsibly.	
Failure to follow this warning may result in personal injury or death.	

### 1 - Compressor

ALL ELS model units use scroll compressors. ELS072, ELS090 and ELS120S4S models have one two-stage scroll compressor. ELS120S4D, ELS150S4D, ELS180S4D and ELS240S4D models have two single-stage scroll compressors.

Compressor consists of two involute spiral scrolls matched together to generate a series of crescent shaped gas pockets between them.

During compression, one scroll remains stationary while the other scroll orbits around it.

Gas is drawn into the outer pocket, the pocket is sealed as the scroll rotates.

As the spiral movement continues, gas pockets are pushed to the center of the scrolls. Volume between the pockets is simultaneously reduced.

When pocket reaches the center, gas is now high pressure and is forced out of a port located in the center of the fixed scrolls.

During compression, several pockets are compressed simultaneously resulting in a smooth continuous compression cycle.

Continuous flank contact, maintained by centrifugal force, minimizes gas leakage and maximizes efficiency.

Scroll compressor is tolerant to the effects of slugging and contaminants. If this occurs, scrolls separate, allowing liquid or contaminants to be worked toward the center and discharged.

Low gas pulses during compression reduces operational sound levels.

Compressor motor is internally protected from excessive current and temperature.

Compressor is installed in the unit on resilient rubber mounts for vibration free operation.

Compressor B1 operates during all cooling demand and is energized by contactor K1 upon receiving first stage demand. Compressor B2 operates only during second stage cooling demand, and is energized by contactor K2. See ELECTRICAL section or compressor nameplate for compressor specifications.

### ELS072, ELS090 and ELS120S4S Two Stage Models

A 24-volt DC solenoid valve inside the compressor controls staging. When the 3-way solenoid is energized it moves the lift ring assembly to block the ports and the compressor operates at full-load or 100% capacity. When the solenoid is de-energized the lift ring assembly moves to unblock the compressor ports and the compressor operates at part-load or approximately 67% of its full-load capacity.

The “loading” and “unloading” of the two stage scroll is done “on the fly” without shutting off the single-speed compressor motor between stages.

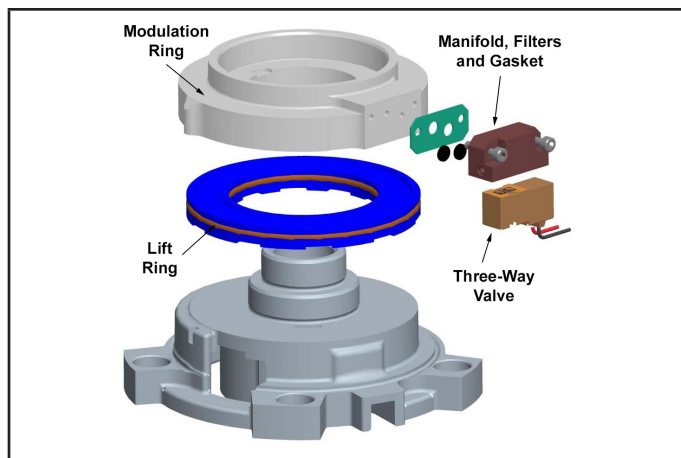

FIGURE 2. Two-Stage Scroll Compressor

### Two Stage Compressor Solenoid (L34) Resistance Check

Resistance check: Measure the resistance from the end of one molded plug lead to either of the two female connectors in the plug. One of the connectors should read close to zero ohms while the other should read infinity. Repeat with other wire. The same female connector as before should read zero while the other connector again reads infinity. Reverse polarity on the ohmmeter leads and repeat. The female connector that read infinity previously should now read close to zero ohms. Replace plug if either of these test methods don't show the desired results.

### 2 - Crankcase Heaters HR1 (all units) and HR2 (120S4D, 150, 180, 240)

All ELS series units use a belly-band type crankcase heater. Heater HR1 is wrapped around compressor B1 and heater HR2 is wrapped around compressor B2. HR1 and HR2 assure proper compressor lubrication at all times.

### 3 - High Pressure Switch S4 (all units) & S7 (120S4D, 150, 180, 240)

The high pressure switch is a manual-reset SPST N.C. switch which opens on a pressure rise. The switch is located in the compressor discharge line and is wired in series with the compressor contactor coil. When discharge pressure rises to 640 + 10 psig (4413 + 69 kP ) the switch opens and the compressor is de-energized.

### 4 - Filter Drier (all units)

All ELS model units have a filter drier that is located in the liquid line of each refrigerant circuit at the exit of each condenser coil. The drier removes contaminants and moisture from the system.

### 5 - Condenser Fan B4 (all units) B5 (120S4S,120S4D, 150, 180, 240) B21 & B22 (180, 240)

See pages 2 and 3 for the specifications on the condenser fans used in the ELS units. All condenser fans have single-phase motors. The ELS072 and 090 units are equipped with a single condenser fan. The ELS120 and 150 are equipped with two fans and the 180 and 240 have four fans. The fan assembly may be removed for servicing by removing the fan grill, unplugging the motor then loosening the motor bracket. The assembly will lift out.

### 6 - Loss of Charge Switch S24 & S25

The loss of charge switch is an auto-reset SPST N.C. switch which opens on a pressure drop (almost a complete loss of charge). All ELS units have S24 and the 120S4D through 240 have S25. The switch is located in the liquid line and wired in series with compressor contactor and high pressure switch. S24 is wired in series with first stage cool and S25 is wired in series with second stage cool. When pressure drops below 40+ 5 psig (indicating loss of charge in the system) the switch opens and compressor is de-energized. The switch automatically resets when refrigerant is added and pressure in the discharge line rises above 90+ 5 psig.

### 7 - Head Pressure Control A190 & A191 and Pressure Transducer A188 & A189

The low ambient kit is designed to maintain the head pressure across the liquid line by varying the condenser speed fan.

Head pressure Control A190 (all units) and A191 (ELS180, 240) is used to set the desired liquid line pressure (315 psig in ELS units). The pressure transducer A190 (All units) A191 (120S4D through 240) measures the liquid line pressure sending an analog signal to the head pressure controller. If pressure falls below set point, the head pressure controller reduces the fan speed to increase the liquid line pressure to the set point.

### 8 - Low Pressure Switch S87 (ELS072, 090 120S4S).

The low pressure switch is an auto-reset SPST N.C. switch which opens on a pressure drop. The switch is located on the suction line and wired in series with compressor contactor and high pressure switch. When pressure drops below 40 ± 5 psig the switch opens and compressor is de-energized. The switch automatically resets when pressure rises above 90 ± 5 psig.

## II- REFRIGERANT SYSTEM

### A-Plumbing

Field refrigerant piping consists of liquid and suction lines connecting the condensing unit and the indoor unit. Liquid and suction service valves are located in a compartment at the corner of the unit below the control box. Piping can be routed directly from the service valves or field supplied elbows can be added to divert the piping as required Refer to table 1 for field-fabricated refrigerant line sizes for runs up to 50 linear feet (15 m).

**TABLE 1**

ELS Unit	Liquid Line	Suction Line
072	3/8" (10mm)	1-1/8" (29mm)
090	5/8" (16mm)	1-1/8" (29mm)
120S4S	5/8" (16mm)	1-1/8" (29mm)
120S4D	3/8" (10mm)	1-1/8" (29mm)
150	3/8" (10mm)	1-1/8" (29mm)
180	5/8" (16mm)	1-1/8" (29mm)
240	5/8" (16mm)	1-1/8" (29mm)

#### Refrigerant Line Limitations

You may install the unit in applications that have line set lengths of up to 50 linear feet (15 m) with refrigerant line sizes as outlined in table 1 (excluding equivalent length of fittings). Size refrigerant lines greater than 50 linear feet (15m or greater) according to the Lennox Refrigerant Piping Design and Fabrication Guidelines (Corp. 9351-L9) or latest version.

### B-Service Valves

#### OPERATING SERVICE VALVES

The liquid and suction line service valves are typically used for removing refrigerant, flushing, leak testing, evacuating, checking charge and charging.

### ⚠ IMPORTANT

Only use Allen wrenches of sufficient hardness (50Rc - Rockwell Harness Scale minimum). Fully insert the wrench into the valve stem recess.

Service valve stems are factory-torqued (from 9 ft-lbs for small valves, to 25 ft-lbs for large valves) to prevent refrigerant loss during shipping and handling. Using an Allen wrench rated at less than 50Rc risks rounding or breaking off the wrench, or stripping the valve stem recess.

Each valve is equipped with a service port which has a factory-installed valve stem.

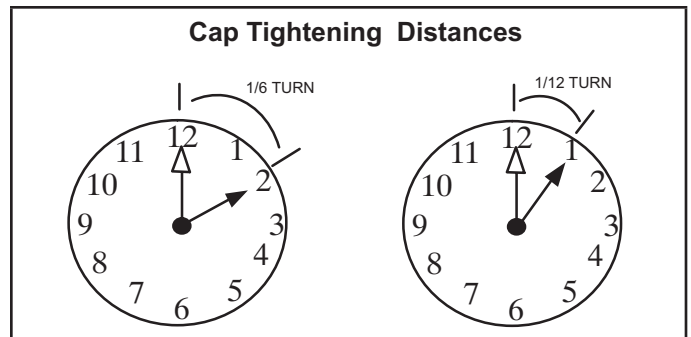

**FIGURE 3**

### ⚠ IMPORTANT

To prevent stripping of the various caps used, the appropriately sized wrench should be used and fitted snugly over the cap before tightening.

**TABLE 2**  
**Torque Requirements**

Part	Recommended Torque	
Service valve cap	8 ft.-lb.	11 NM
Sheet metal screws	16 in.-lb.	2 NM
Machine screws #10	28 in.-lb.	3 NM
Compressor bolts	90 in.-lb.	10 NM
Gauge port seal cap	8 ft.-lb.	11 NM

#### To Access Angle-Type Service Port:

A service port cap protects the service port core from contamination and serves as the primary leak seal.

- 1 - Remove service port cap with an appropriately sized wrench.
- 2 - Connect gauge to the service port.
- 3 - When testing is completed, replace service port cap and tighten as follows:
  - *With Torque Wrench:* Finger tighten and then tighten per table 2.
  - *Without Torque Wrench:* Finger tighten and use an appropriately sized wrench to turn an additional 1/6 turn clockwise as illustrated in figure 2.

#### To Open Liquid Line Service Valve:

- 1 - Remove stem cap with an adjustable wrench.
- 2 - Using service wrench and 5/16" hex head extension if needed (part #49A71) back the stem out counterclockwise until the valve stem just touches the retaining ring.
- 3 - Replace stem cap. Tighten finger tight, then tighten an additional 1/6 turn. Do not over torque.

#### To Close Liquid Line Service Valve:

- 1 - Remove stem cap with an adjustable wrench.
- 2 - Using service wrench and 5/16" hex head extension if needed (part #49A71), turn stem clockwise to seat the valve. Tighten firmly.

- 3 - Replace stem cap. Tighten finger tight, then tighten an additional 1/6 turn. Do not over torque.

### Service (Ball) Valve

Some ELS units are equipped with a full service ball valve, as shown in figure 4. One service port that contains a valve core is present in this valve. A cap is also provided to seal off the service port. The valve is not rebuildable so it must always be replaced if failure has occurred.

#### Opening the Suction Line Service Valve

- 1 - Remove the stem cap with an adjustable wrench.
- 2 - Using a service wrench, turn the stem counterclockwise for 1/4 of a turn.
- 3 - Replace the stem cap and tighten it firmly.

#### Closing the Suction Line Service Valve

- 1 - Remove the stem cap with an adjustable wrench.
- 2 - Using a service wrench, turn the stem clockwise for 1/4 of a turn.
- 3 - Replace the stem cap and tighten firmly.

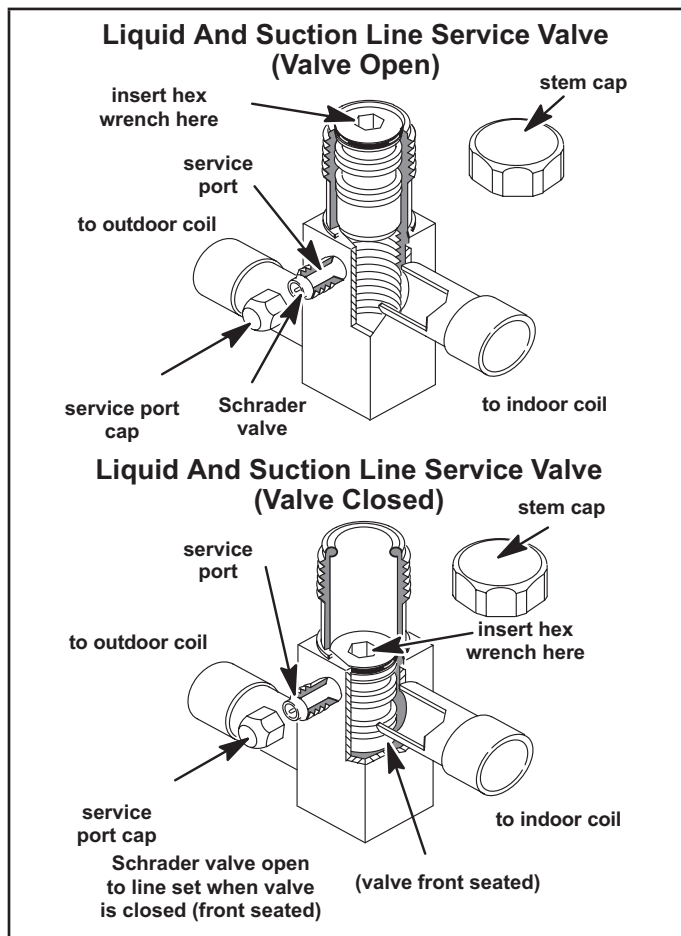

FIGURE 4

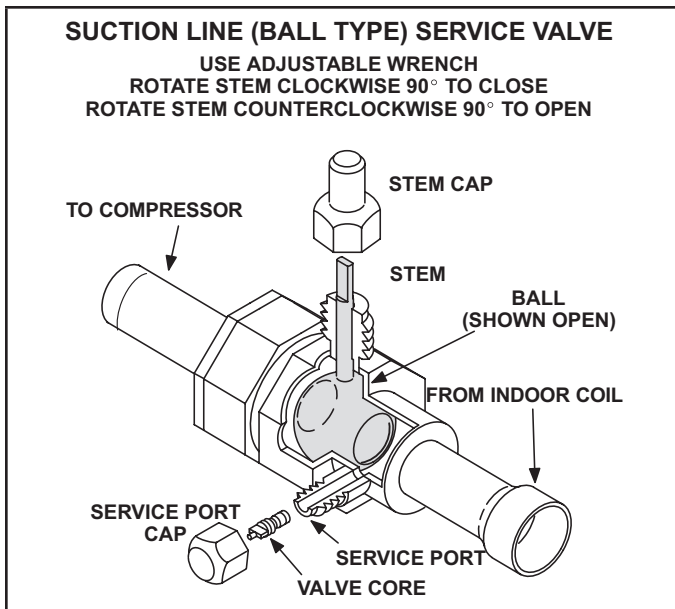

FIGURE 5

### III-START-UP

The following is a general procedure and does not apply to all thermostat control systems. Refer to sequence of operation in this manual for more information.

#### **! IMPORTANT**

Crankcase heaters must be energized for 24 hours before attempting to start compressors. Set thermostat so there is no compressor demand before closing disconnect switch. Attempting to start compressors during the 24-hour warm-up period could result in damage or failed compressors.

- 1 - Set fan switch to AUTO or ON and move the system selection switch to COOL. Adjust the thermostat to a setting far enough below room temperature to bring on compressors. Compressors will start and cycle on demand from the thermostat (allowing for unit and thermostat time delays).
- 2 - Each circuit is field charged with HCFC-410A refrigerant.
- 3 - Refer to Charging section for proper method of checking and charging the system.

#### **! IMPORTANT**

Three-phase scroll compressors must be phased sequentially to ensure correct compressor rotation and operation. At compressor start-up, a rise in discharge and drop in suction pressures indicate proper compressor phasing and operation. If discharge and suction pressures do not perform normally, follow the steps below to correctly phase in the unit.

- 1 - Disconnect power to the unit.
- 2 - Reverse any two field power leads (L1 and L3 preferred) to the unit.
- 3 - Reapply power to the unit.



Discharge and suction pressures should operate at their normal start-up ranges.

**NOTE** - Compressor noise level will be significantly higher when phasing is incorrect and the unit will not provide cooling when compressor is operating backwards. Continued backward operation will cause the compressor to cycle on internal protector.

## IV-CHARGING

### A-Leak Testing

 <b>WARNING</b>	
Refrigerant can be harmful if it is inhaled. Refrigerant must be used and recovered responsibly.	
Failure to follow this warning may result in personal injury or death.	

 <b>WARNING</b>	
	Fire, Explosion and Personal Safety hazard. Failure to follow this warning could result in damage, personal injury or death.
	Never use oxygen to pressurize or purge refrigeration lines. Oxygen, when exposed to a spark or open flame, can cause fire and/or an explosion, that could result in property damage, personal injury or death.

- 1 - Connect an HFC-410A manifold gauge set as illustrated in figure 6.
- 2 - Open the valve on the HFC-410A cylinder (suction only).
- 3 - Open the high pressure side of the manifold to allow HFC-410A into the line set and indoor unit. Weigh in a trace amount of HFC-410A. [A trace amount is a maximum of two ounces (57 g) refrigerant or three pounds (31 kPa) pressure].
- 4 - Close the valve on the HFC-410A cylinder and the valve on the high pressure side of the manifold gauge set.
- 5 - Disconnect the HFC-410A cylinder.
- 6 - Connect a cylinder of dry nitrogen with a pressure regulating valve to the center port of the manifold gauge set.
- 7 - Adjust dry nitrogen pressure to 150 psig (1034 kPa). Open the valve on the high side of the manifold gauge set in order to pressurize the line set and the indoor unit.
- 8 - After a few minutes, open one of the service valve ports and verify that the refrigerant added to the system earlier is measurable with a leak detector.

**NOTE** - Amounts of refrigerant will vary with line lengths.

- 9 - Check all joints for leaks.
- 10 - Purge dry nitrogen and HFC-410A mixture.
- 11 - Correct any leaks and recheck.
- 12 - After leak testing, disconnect gauges from service ports.



- A** Connect an HFC-410A manifold gauge set high pressure hose to the suction valve service port.
- B** With both manifold valves closed, connect the cylinder of HFC-410A refrigerant to the center port of the manifold gauge set.
- C** After the line set has been connected to both the indoor and outdoor units, check the line set connections and indoor unit for leaks. Use the following procedure to test for leaks:

NOTE - LATER IN THE PROCEDURE, THE HFC-410A CONTAINER WILL BE REPLACED BY THE NITROGEN CONTAINER.

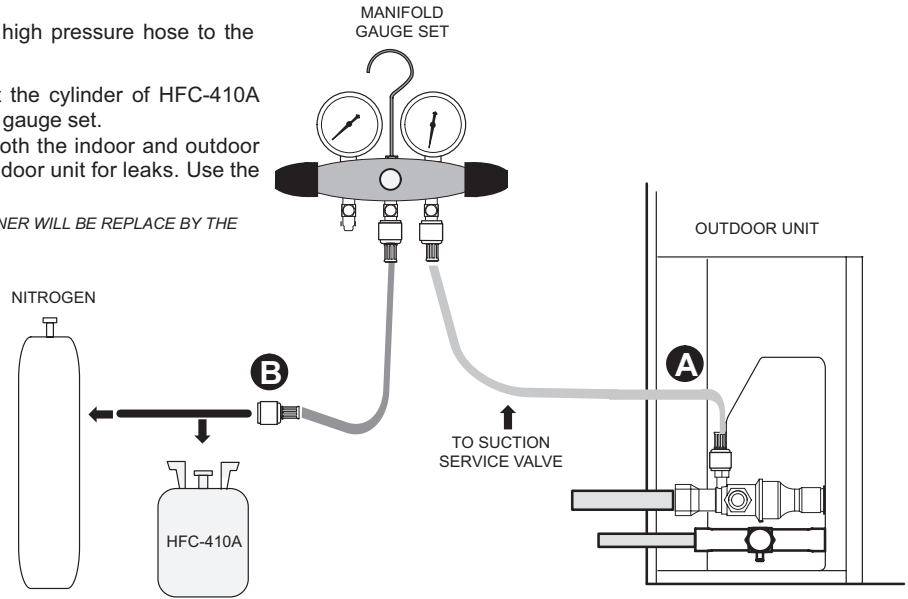

**FIGURE 6**

### B-Evacuating the System

NOTE - Remove cores from service valves if not already done.

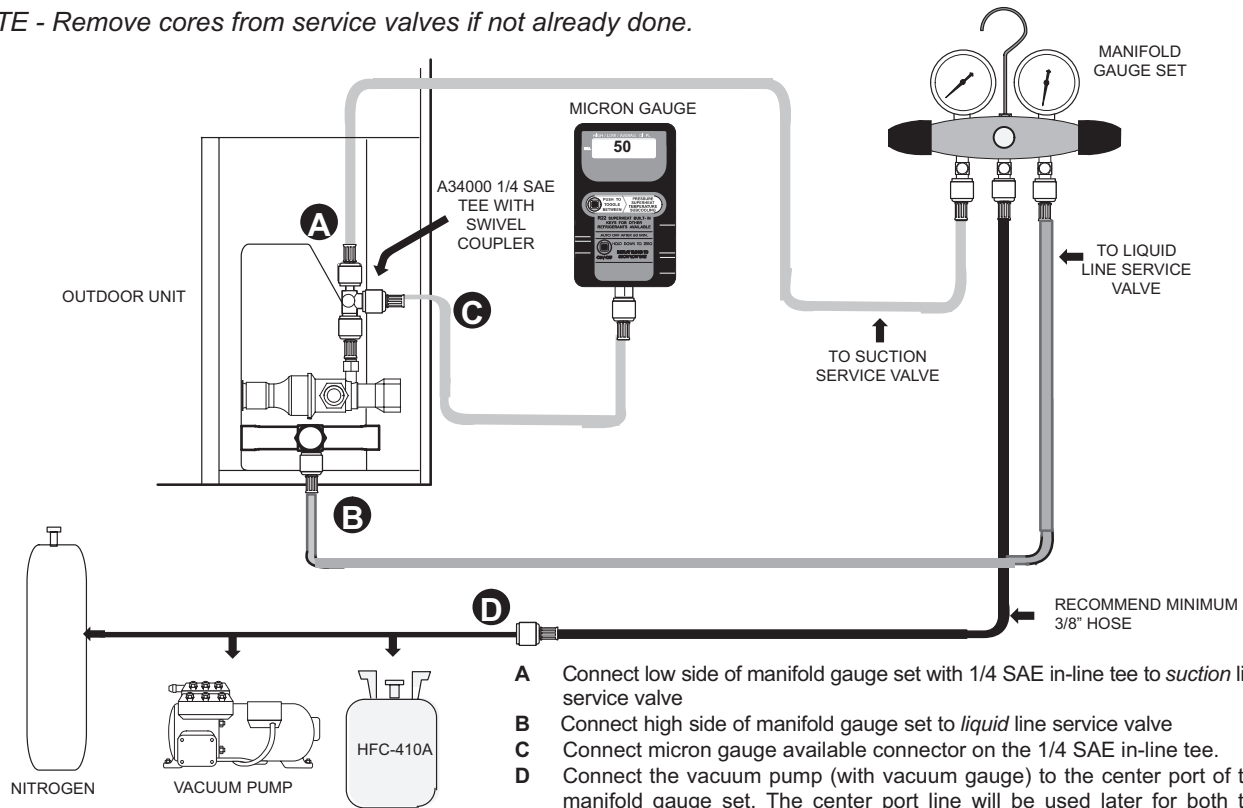

- A** Connect low side of manifold gauge set with 1/4 SAE in-line tee to suction line service valve
- B** Connect high side of manifold gauge set to liquid line service valve
- C** Connect micron gauge available connector on the 1/4 SAE in-line tee.
- D** Connect the vacuum pump (with vacuum gauge) to the center port of the manifold gauge set. The center port line will be used later for both the HFC-410A and nitrogen containers.

**FIGURE 7**

## ⚠ WARNING

Possible equipment damage.

Avoid deep vacuum operation. Do not use compressors to evacuate a system. Extremely low vacuum can cause internal arcing and compressor failure. Damage caused by deep vacuum operation will void warranty.

## ⚠ IMPORTANT

Use a thermocouple or thermistor electronic vacuum gauge that is calibrated in microns. Use an instrument capable of accurately measuring down to 50 microns.

Evacuating the system of non-condensables is critical for proper operation of the unit. Non-condensables are defined as any gas that will not condense under temperatures and pressures present during operation of an air conditioning system. Non-condensables and water suction combine with refrigerant to produce substances that corrode copper piping and compressor parts.

**NOTE** - Remove cores from service valves if not already done.

- 1 - Connect an HFC-410A manifold gauge set as illustrated in figure 5.
- 2 - Open both manifold valves and start the vacuum pump.
- 3 - Evacuate the line set and indoor unit to an absolute pressure of 23,000 microns (29 inches of mercury).

**NOTE** - During the early stages of evacuation, it is desirable to close the manifold gauge valve at least once to determine if there is a rapid rise in pressure this indicates a relatively large leak. If this occurs, repeat the leak testing procedure.

**NOTE** - The term absolute pressure means the total actual pressure within a given volume or system, above the absolute zero of pressure. Absolute pressure in a vacuum is equal to atmospheric pressure minus vacuum pressure.

- 4 - When the absolute pressure reaches 23,000 microns (29 inches of mercury), close the manifold gauge valves, turn off the vacuum pump and disconnect the manifold gauge center port hose from vacuum pump. Attach the manifold center port hose to a dry nitrogen cylinder with pressure regulator set to 150 psig (1034 kPa) and purge the hose.

Open the manifold gauge valves to break the vacuum in the line set and indoor unit. Close the manifold gauge valves.

- 5 - Shut off the dry nitrogen cylinder and remove the manifold gauge hose from the cylinder. Open the manifold gauge valves to release dry nitrogen from the line set and indoor unit.
- 6 - Reconnect the manifold gauge to vacuum pump, turn pump on, and continue to evacuate line set and indoor unit until the absolute pressure does not rise above 500 microns within a 20-minute period after shutting off vacuum pump and closing the manifold gauge valves.
- 7 - When the absolute pressure requirement above has been met, disconnect the manifold hose from the vacuum pump and connect it to an upright cylinder of HFC-410A refrigerant. Open the manifold gauge valve pressure line set to break vacuum with 2 to 5 psi.
- 8 - Perform the following:
  - A - Close manifold gauge valves
  - B - Shut off HFC-410A cylinder
  - C - Reinstall service valve cores by removing manifold hose from service valve. Quickly install cores with core tool while maintaining a positive system pressure.
  - D - Replace the stem caps and secure finger tight, then tighten an additional one-sixth (1/6) of a turn as illustrated in figure 3.

### C-Charging

ELS units have a factory holding charge of 2 pounds of HFC-410A in each circuit. Additional refrigerant will need to be added during installation.

To charge the system, use the following procedure:

- 1 - Measure actual length of liquid and vapor lines for each circuit.
- 2 - Add refrigerant to each circuit based on measured liquid and suction line lengths.
  - A - If the measured line length is greater than 25 feet, add refrigerant (refer to table 3).
  - B - If the measured line length is less than 25 feet, remove refrigerant (refer to table 3).

**TABLE 3. Adding Refrigerant**

Models	Total lbs – Stage 1 with 25ft line set	Total lbs – Stage 2 with 25ft line set	Liquid Line Diameter	Ounces Adjustment per foot of liquid line	Suction Line Diameter	Ounces Adjustment per foot of suction line
ELS072S4S	18.5	N/A	3/8	0.5	1-1/8	0.2
ELS090S4S	21.75	N/A	5/8	1.5	1-1/8	0.2
ELS120S4S	23	N/A	5/8	1.5	1-1/8	0.2
ELS120S4D	12	12	3/8	1.5	1-1/8	0.2
ELS150S4D	15	15.5	3/8	0.5	1-1/8	0.2
ELS180S4D	23.75	23.5	5/8	1.5	1-1/8	0.2
ELS240S4D	22.5	23.5	5/8	1.5	1-1/8	0.2

- 3 - Check normal operating pressures:
- A - Connect a manifold gauge set to the service valves:
- Low pressure gauge to vapor valve service port
  - High pressure gauge to liquid valve service port
- B - Operate the system until pressures and temperatures stabilize (5 minutes minimum).
- C - Use a thermometer to measure the outdoor ambient temperature.
- D - If the outdoor temperature is greater than 65°F (18°C):
- Apply the outdoor ambient temperature to tables 5, 6 or 8 to determine normal operating pressures. Compare the normal operating pressures to the pressures obtained from the connected gauges. If liquid pressure is high, remove refrigerant from the system. If liquid pressure is low, add refrigerant to the system.
  - Add or remove charge in increments.
  - Allow the system to stabilize at least 5 minutes each time refrigerant is added or removed.
  - Minor variations in these pressures may be expected due to differences in installations. Significant differences could mean that the system is not properly charged or that a problem exists with some component in the system.
- 4 - If the outdoor ambient temperature is below 65°F (18°C) it may be necessary to restrict the air flow through the outdoor coil to achieve liquid pressures in the 325-375 psig (2240-2585 kPa) range. These higher pressures are necessary for checking the charge. Block equal sections of the outdoor coil on all coil sides until the liquid pressure is in the 325-375 psig range (figure 8).

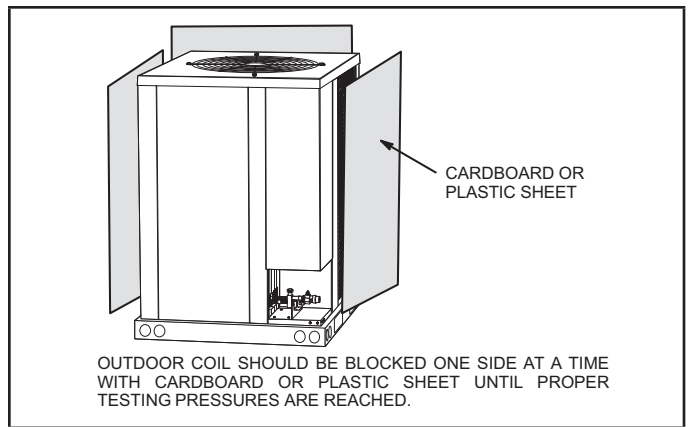

**FIGURE 8. Blocking Outdoor Coil**

A - Charge the unit using the approach method in the next section:

- Using the same thermometer, compare liquid temperature at service valve to outdoor ambient temperature.

**Approach Temperature = Liquid temperature minus ambient temperature**

- Approach temperature should be as indicated in tables 3 or 6 for each stage. An approach temperature greater than this value indicates an undercharge. An approach temperature less than this value indicates an overcharge.
- Add or remove charge in increments.
- Allow system to stabilize at least 5 minutes each time refrigerant is added or removed.
- Do not use the approach method if system pressures do not match pressures in table 5, 6 or 8 except when the outdoor ambient temperature is below 65°F (18°C).
- The approach method is not valid for grossly over or undercharged systems.

**TABLE 4. Approach Temperatures – Commercial Matchups**

Models		Approach Temperature		
Outdoor	Indoor	Stage	(°F) (+/- 1)	(°C) (+/- 0.5)
ELS072S4S	ELA072S4S	1	4	2.2
ELS090S4S	ELA090S4D	1	7	3.9
ELS120S4S	ELA120S4D	1	4	2.2
ELS120S4D	ELA120S4D	1	5	2.8
		2	5	2.8
ELS150S4D	ELA150S4D	1	7	3.9
		2	5	2.8
ELS180S4D	ELA180S4D	1	4	2.2
		2	4	2.2
ELS240S4D	ELA240S4D	1	7	3.9
		2	8	4.4

**TABLE 5. Normal Operating Pressures – Cooling – Single Stage – Commercial\***

Entering Outdoor Air Temp °F (°C)	ELS072 + ELA072		ELS072 + ELA090		ELS090 + ELA090		ELS090 + ELA120		ELS120S4S + ELA120	
	STAGE 1		STAGE 1		STAGE 1		STAGE 1		STAGE 1	
	Liquid	Suction	Liquid	Suction	Liquid	Suction	Liquid	Suction	Liquid	Suction
65 (18)	245	137	252	144	240	128	251	130	243	135
75 (24)	283	141	292	146	294	130	292	132	285	136
85 (29)	327	143	336	148	338	131	336	134	332	138
95 (35)	377	145	385	150	385	133	384	136	378	139
105 (41)	426	148	438	152	435	135	436	139	434	141
115 (46)	484	150	495	154	489	136	492	141	491	142
125 (52)	540	155	558	157	545	140	553	144	548	146
SCFM	2600		2750		2725		2750		3850	

\*pressures at 80F dry bulb and 67F wet bulb entering indoor air temperatures.

**TABLE 6. Normal Operating Pressures – Cooling – Two Stage – Commercial\***

Entering Outdoor Air Temp °F (°C)	(2) ELS090 + ELA180				ELS120S4D + ELA120			
	STAGE 1		STAGE 2		STAGE 1		STAGE 2	
	Liquid	Suction	Liquid	Suction	Liquid	Suction	Liquid	Suction
65 (18)	248	122	247	120	244	133	240	133
75 (24)	288	125	287	122	282	136	278	135
85 (29)	332	127	331	125	326	139	322	137
95 (35)	379	129	378	127	373	141	372	138
105 (41)	432	132	430	130	423	142	420	141
115 (46)	488	135	487	133	477	144	476	143
125 (52)	550	138	548	136	537	147	539	145
SCFM	5150				4000			

Entering Outdoor Air Temp °F (°C)	(2) ELS120S4S + ELA240				ELS150 + ELA150			
	STAGE 1		STAGE 2		STAGE 1		STAGE 2	
	Liquid	Suction	Liquid	Suction	Liquid	Suction	Liquid	Suction
65 (18)	241	130	237	130	254	132	254	130
75 (24)	284	134	280	134	291	135	289	133
85 (29)	331	136	327	135	337	138	336	134
95 (35)	380	138	376	137	381	140	382	136
105 (41)	434	141	429	140	432	142	433	139
115 (46)	491	143	490	142	487	144	489	141
125 (52)	540	145	540	145	543	147	550	145
SCFM	7400				4395			

Entering Outdoor Air Temp °F (°C)	ELS150 + ELA180				ELS180 + ELA180			
	STAGE 1		STAGE 2		STAGE 1		STAGE 2	
	Liquid	Suction	Liquid	Suction	Liquid	Suction	Liquid	Suction
65 (18)	258	135	260	135	233	110	236	110
75 (24)	298	137	300	137	274	120	276	119
85 (29)	343	139	346	139	317	128	319	125
95 (35)	390	141	395	141	364	134	366	131
105 (41)	444	144	448	144	418	138	416	132
115 (46)	501	146	508	146	475	141	468	134
125 (52)	563	149	571	149	536	143	529	136
SCFM	5150				5150			

Entering Outdoor Air Temp °F (°C)	ELS180 + (2) ELA090				ELS180 + ELA240			
	STAGE 1		STAGE 2		STAGE 1		STAGE 2	
	Liquid	Suction	Liquid	Suction	Liquid	Suction	Liquid	Suction
65 (18)	229	118	230	129	239	139	238	140
75 (24)	266	129	267	134	279	141	277	141
85 (29)	310	136	311	137	322	143	320	143
95 (35)	359	136	358	137	370	145	367	145
105 (41)	407	137	408	141	423	147	420	147
115 (46)	465	138	463	142	480	149	477	150
125 (52)	526	139	522	143	544	152	541	152
SCFM	5400				7125			

Entering Outdoor Air Temp °F (°C)	ELS240 + ELA240				ELS240 + (2) ELA120			
	STAGE 1		STAGE 2		STAGE 1		STAGE 2	
	Liquid	Suction	Liquid	Suction	Liquid	Suction	Liquid	Suction
65 (18)	236	129	236	128	243	133	244	133
75 (24)	275	132	275	129	283	135	284	135
85 (29)	321	134	322	131	327	137	328	137
95 (35)	370	137	368	133	374	139	377	139
105 (41)	420	139	425	136	427	141	430	141
115 (46)	477	142	478	139	484	144	486	144
125 (52)	539	146	534	144	545	146	548	146
SCFM	7075				8000			

\*pressures at 80F dry bulb and 67F wet bulb entering indoor air temperatures.

**TABLE 7. Approach Temperatures – Residential Matchups**

Models		Approach Temperature		
Outdoor	Indoor	Stage	(°F) (+/- 1)	(°C) (+/- 0.5)
ELS120S4D	(2) CBA27UHE-060 or (2) CBA38MV-060	1	4	2.2
		2	4	2.2
ELS120S4D	(2) CH33-62D	1	4	2.2
		2	4	2.2
ELS120S4D	(2) CH23-068	1	4	2.2
		2	4	2.2
ELS120S4D	(2) CX35-60C	1	4	2.2
		2	4	2.2
ELS120S4D	(2) CX35-60D	1	4	2.2
		2	4	2.2

**TABLE 8. Normal Operating Pressures – Single and Two Stage – Residential**

Entering Outdoor Air Temp °F (°C)	ELS090 + (2) CX35-060C		ELS090 + (2) CX35-060D	
	STAGE 1		STAGE 1	
°F (°C)	Liquid	Suction	Liquid	Suction
65 (18)	255	139	253	134
75 (24)	295	142	293	137
85 (29)	340	145	338	140
95 (35)	389	147	386	143
105 (41)	442	150	439	146
115 (46)	498	153	496	149
125 (52)	559	156	558	153
SCFM	3000		3000	

Entering Outdoor Air Temp °F (°C)	ELS120S4D + (2) CBA27UHE-060 or (2) CBA38MV-060				ELS120S4D + (2) CH33-62D				ELS120S4D + (2) CH23-068			
	STAGE 1		STAGE 2		STAGE 1		STAGE 2		STAGE 1		STAGE 2	
	Liquid	Suction	Liquid	Suction	Liquid	Suction	Liquid	Suction	Liquid	Suction	Liquid	Suction
65 (18)	251	133	250	131	240	125	241	125	241	128	242	128
75 (24)	292	135	287	134	280	129	282	128	281	131	283	131
85 (29)	340	137	333	136	324	132	326	131	325	134	326	133
95 (35)	391	140	384	139	372	135	374	134	373	137	375	136
105 (41)	446	143	441	142	425	139	427	137	427	141	428	139
115 (46)	505	145	501	144	483	143	484	141	484	144	486	142
125 (52)	569	148	566	147	545	146	548	145	547	147	550	146
SCFM	3615				3200				3200			

Entering Outdoor Air Temp °F (°C)	ELS120S4D + (2) CX35-60C				ELS120S4D + (2) CX35-60D			
	STAGE 1		STAGE 2		STAGE 1		STAGE 2	
	Liquid	Suction	Liquid	Suction	Liquid	Suction	Liquid	Suction
65 (18)	241	130	243	129	240	127	241	127
75 (24)	282	133	282	132	281	130	282	130
85 (29)	326	136	327	135	325	134	327	133
95 (35)	374	139	375	138	373	137	374	136
105 (41)	427	142	428	141	427	141	428	139
115 (46)	485	145	486	144	484	145	486	143
125 (52)	548	148	550	147	548	148	550	146
SCFM	3200				3200			

## V-MAINTENANCE

Installation and service must be performed by a licensed professional installer (or equivalent) or a service agency. At the beginning of each cooling season, the system should be checked as follows:

<b>⚠ WARNING</b>	
	<p>Electric Shock Hazard. Can cause injury or death. Unit must be properly grounded in accordance with national and local codes.</p> <p>Line voltage is present at all components when unit is not in operation on units with single-pole contactors. Disconnect all remote electric power supplies before opening access panel. Unit may have multiple power supplies.</p>

### OUTDOOR UNIT

- 1 - Clean and inspect outdoor coil (may be flushed with a water hose). Ensure power is off before cleaning.
- 2 - Outdoor unit fan motor is pre-lubricated and sealed. No further lubrication is needed.
- 3 - Visually inspect all connecting lines, joints and coils for evidence of oil leaks.
- 4 - Check all wiring for loose connections.
- 5 - Check for correct voltage at unit (unit operating).
- 6 - Check amp draw on outdoor fan motor.

**UNIT NAMEPLATE:** \_\_\_\_\_ **ACTUAL:** \_\_\_\_\_

**NOTE** – If insufficient heating or cooling occurs, the unit should be gauged and refrigerant charge should be checked.

### INDOOR COIL

- 1 - Clean coil if necessary.
- 2 - Check connecting lines, joints and coil for evidence of oil leaks.
- 3 - Check condensate line and clean if necessary.

### INDOOR UNIT

- 1 - Clean or change filters.
- 2 - Blower motors are pre-lubricated and permanently sealed. No more lubrication is needed.
- 3 - Adjust blower speed for cooling. Measure the pressure drop over the coil to determine the correct blower CFM. Refer to the unit information service manual for pressure drop tables and procedure.
- 4 - Belt Drive Blowers - Check belt for wear and proper tension.
- 5 - Check all wiring for loose connections.
- 6 - Check for correct voltage at unit. (blower operating)
- 7 - Check amp draw on blower motor.

**UNIT NAMEPLATE:** \_\_\_\_\_ **ACTUAL:** \_\_\_\_\_

# VI-Wiring Diagram and Sequence of Operation

A-ELS072-120S

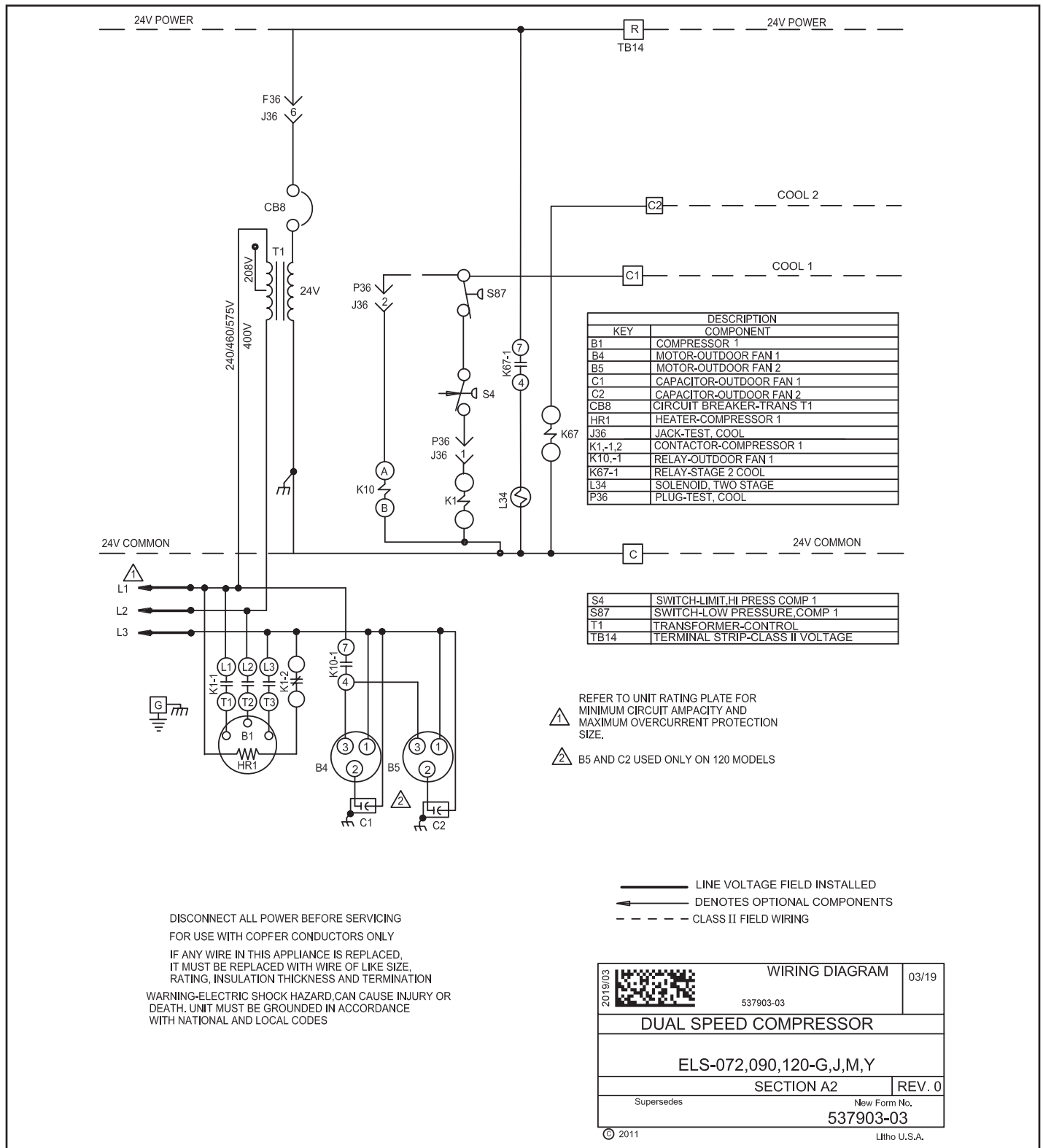

- 1 - Cooling demand energizes at thermostat terminal Y1. Voltage passes through N.C. low pressure switch S87 and N.C. high pressure switch S4.
- 2 - Compressor contactor K1 and outdoor fan relay K10 are energized.
- 3 - K1-1 closes, energizing compressor B1 on low

- 4 - On two-speed systems, voltage passes through K67-1, energizes compressor solenoid L34, switching compressor to high speed.



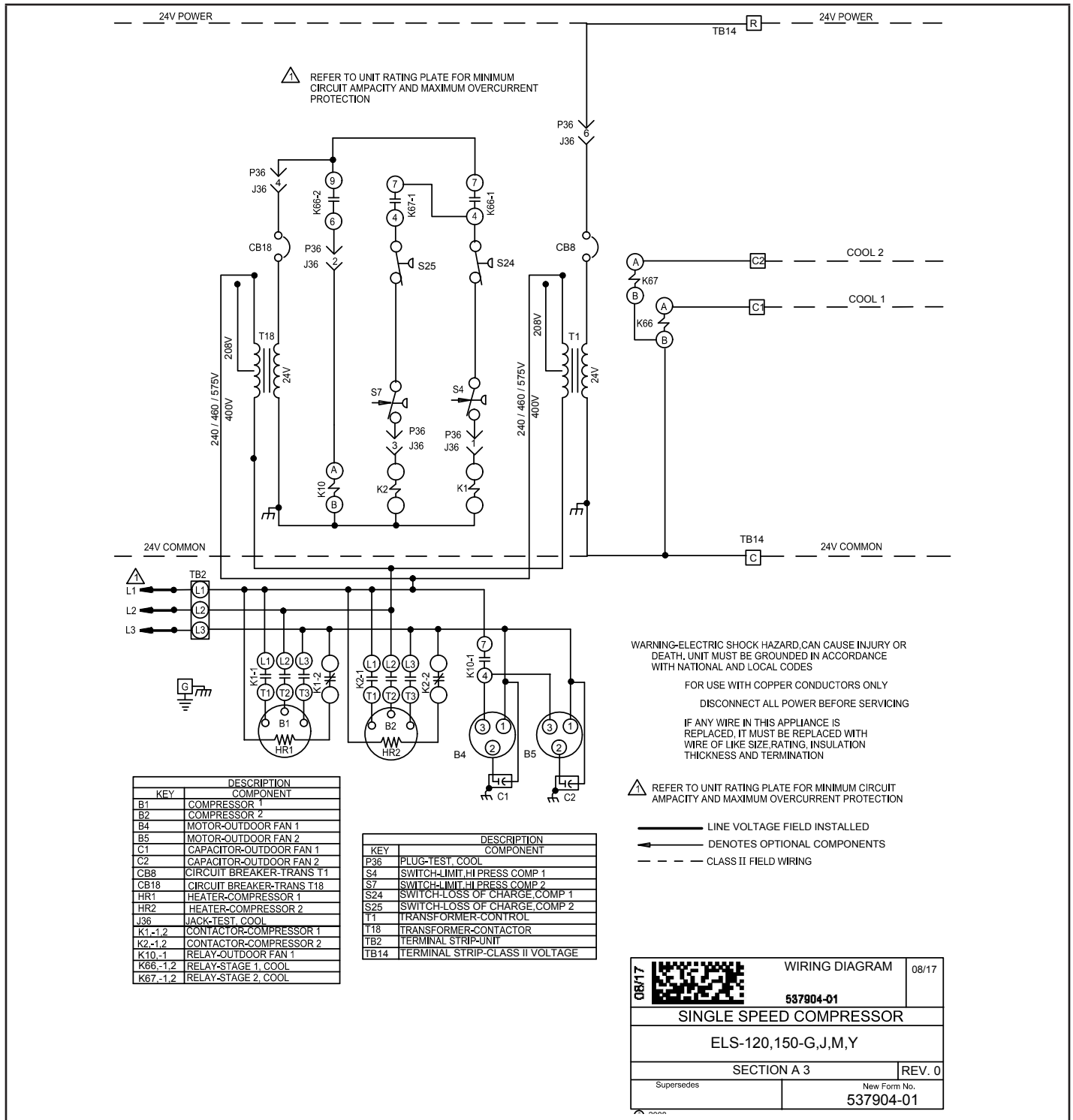

**First Stage Cool**

- 1 - Cooling demand energizes K66 relay coil at thermostat terminal Y1.
- 2 - K66-1 contacts close, voltage passes through S24 loss of charge switch and high pressure switch S4, energizing compressor contactor K1.
- 3 - At the same time, K66-2 contacts close, energizing outdoor fan relay K10.
- 4 - K1-1 closes, energizing compressor B1. K10-1 closes energizing outdoor fans B4 and B5. K1-2

opens to de-energize crankcase heater HR1.

**Second Stage Cool**

- 5 - Cooling demand energizes K67 relay coil at thermostat terminal Y2.
- 6 - K67-1 contacts close, voltage passes through S25 loss of charge switch and S7 high pressure switch energizing compressor contactor K2.
- 7 - K2-1 closes energizing compressor B2. K2-2 opens to de-energize crankcase heater HR2.

08/17	WIRING DIAGRAM	08/17
	<b>537904-01</b>	
<b>SINGLE SPEED COMPRESSOR</b>		
<b>ELS-120,150-G,J,M,Y</b>		
SECTION A 3		REV. 0
Supersedes	New Form No. <b>537904-01</b>	

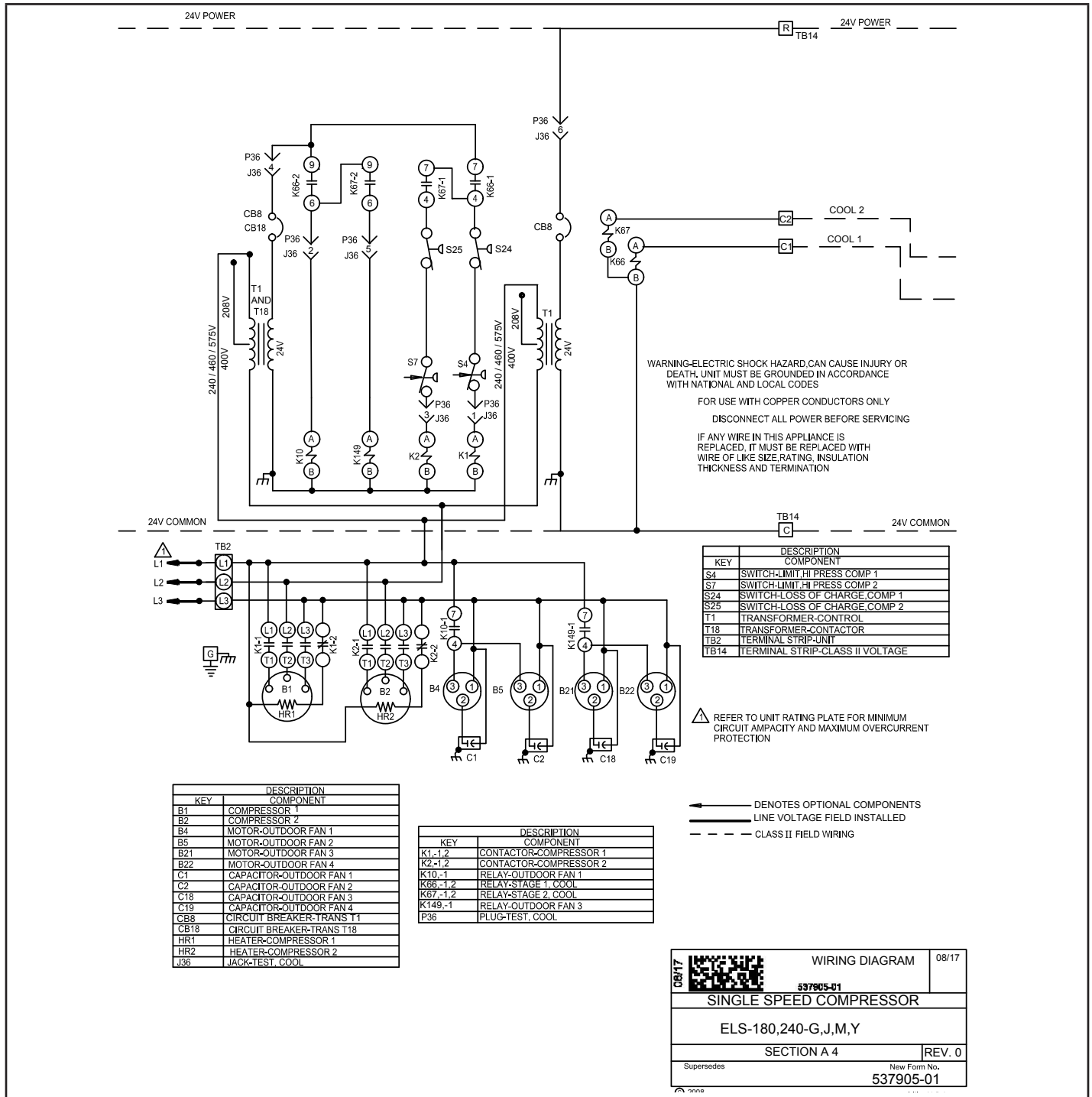

**First Stage Cool**

- 1 - Cooling demand energizes K66 relay coil at thermostat terminal Y1.
- 2 - K66-1 contacts close, voltage passes through S24 loss of charge switch and high pressure switch S4 energizing contactor K1.
- 3 - At the same time, K66-2 closes energizing relay K10.
- 4 - K1-1 contacts close, energizing compressor B1. K10-1 contacts close energizing outdoor fans B4 and B5. K1-2 opens to de-energize crankcase heater HR1.

**Second Stage Cool**

- 5 - Cooling demand energizes K67 relay coil at thermostat terminal Y2.
- 6 - K67-1 contacts close, voltage passes through S25 loss of charge switch and S7 high pressure switch energizing K2.
- 7 - At the same time, K67-2 closes, energizing relay K149.
- 8 - K2-1 contacts close energizing compressor B2 and K149-1 contacts close, energizing outdoor fans B21 and B22. K2-2 opens to de-energize crankcase heater HR2.