

CBA25UHV (HFC-410A) SERIES UNITS



⚠ WARNING

Improper installation, adjustment, alteration, service or maintenance can cause property damage, personal injury or loss of life. Installation and service must be performed by a licensed professional HVAC installer or equivalent, service agency, or the gas supplier.

⚠ IMPORTANT

The Clean Air Act of 1990 bans the intentional venting of refrigerant (CFCs, HCFCs and HFCs) as of July 1, 1992. Approved methods of recovery, recycling or reclaiming must be followed. Fines and/or incarceration may be levied for noncompliance.

NOTICE

A thermostat is not included and must be ordered separately.

- A Lennox communicating thermostat must be used in communicating applications.
- In non-communicating applications, the Lennox ComfortSense® thermostat may be used, as well as other non-communicating thermostats.

In all cases, setup is critical to ensure proper system operation.

Field wiring for both communicating and non-communicating applications is illustrated in diagrams, which begin on page 29.

⚠ CAUTION

As with any mechanical equipment, contact with sharp sheet metal edges can result in personal injury. Take care while handling this equipment and wear gloves and protective clothing.

Table of Contents

CBA25UHV Unit Dimensions – Upflow – inches (mm)...2
 Specifications and Electrical Data3
 Model Number Identification.....4
 Adjusting the BDC3 Blower Control4
 Adjusting the Blower Speed4
 Blower Data6
 Application10
 Unit Components.....10
 ECBA25 Electric Heat Data.....12
 Heat Section Installation.....17
 Configuration Modification19
 Brazing Connections22
 Installing the Condensate Drain24
 Electrical Connections26
 Inspecting and Replacing Filters27
 Wiring Diagrams.....28
 Professional Maintenance30
 Check-out Procedures30
 Sequence of Operation31

General Information

This indoor unit **with all-aluminum coil** is designed for installation with optional field-installed electric heat and a matched outdoor unit that is charged with HFC-410A refrigerant. These units, designed for indoor installation in multiple positions, are completely assembled for upflow and horizontal right-hand discharge before being shipped from the factory.

All CBA25UHV air handlers are equipped with a factory-installed, internally mounted check / expansion valve, which is suitable for use in HFC-410A applications.

This air handler is compatible with the ComfortSense® non-communicating thermostat and non-communicating outdoor units. In addition, this unit has the enhanced capability of communicating with communicating thermostats and communicating outdoor units using the Lennox RSBus protocols.

NOTE - For downflow or horizontal left-hand air discharge, certain field modifications are required.

IMPORTANT: Special procedures are required for cleaning the all-aluminum coil in this unit. See page 30 in this instruction for information.

CBA25UHV Unit Dimensions – Upflow – inches (mm)

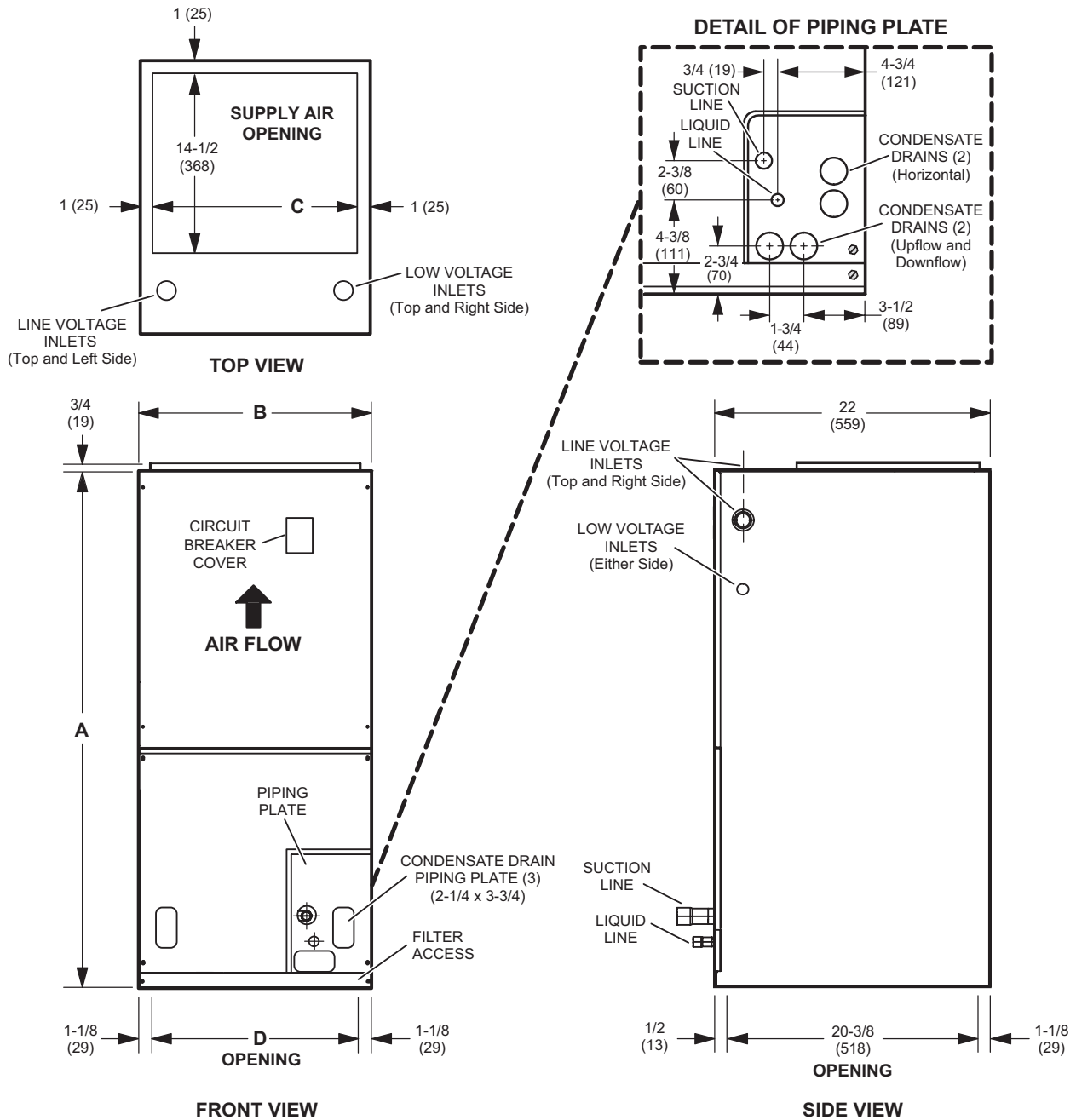

Dimensions	018		024		030		036, 042		048		060	
	in.	mm	in.	mm	in.	mm	in.	mm	in.	mm	in.	mm
A	43-1/2	1105	45-1/2	1156	47	1194	53-5/8	1362	55	1397	59-3/4	1518
B	18-1/2	470	18-1/2	470	18-1/2	470	21-1/2	546	21-1/2	546	21-1/2	546
C	16-1/2	419	16-1/2	419	16-1/2	419	19-1/2	495	19-1/2	495	19-1/2	495
D	16-1/4	413	16-1/4	413	16-1/4	413	19-1/4	489	19-1/4	489	19-1/4	489

NOTE - Unit is shipped configured for horizontal right-hand air discharge. Unit may be converted to horizontal left-hand air discharge by repositioning horizontal drain pan.

Dimensions remain the same in all configurations.

Specifications and Electrical Data

SPECIFICATIONS

General Data		Model Number	CBA25UHV-018	CBA25UHV-024	CBA25UHV-030	CBA25UHV-036
		Nominal tonnage	1.5	2	2.5	3
Connections	Suction/Vapor line (o.d.) - in. sweat		3/4	3/4	3/4	7/8
	Liquid line (o.d.) - in. sweat		3/8	3/8	3/8	3/8
	Condensate - in. fpt		(2) 3/4	(2) 3/4	(2) 3/4	(2) 3/4
Indoor Coil	Net face area - ft. ²		3.30	3.77	4.72	5.66
	Tube outside diameter - in.		3/8	3/8	3/8	3/8
	Number of rows		3	3	3	3
	Fins per inch		15	15	15	15
Blower	Wheel nominal diameter x width - in.		9 x 6	9 x 6	10 x 8	10 x 8
	Blower motor output - hp		1/2	1/2	1/2	1/2
¹ Filters	Size of filter - in.		15 x 20 x 1	15 x 20 x 1	15 x 20 x 1	18 x 20 x 1
Shipping Data -1 package - lbs.			129	136	143	169

ELECTRICAL DATA

Voltage - 1 phase (60 Hz)		208/230V	208/230V	208/230V	208/230V
² Maximum overcurrent protection (unit only)		15	15	15	15
³ Minimum circuit ampacity (unit only)		4.9	4.9	4.9	4.9
Blower Motor Full Load Amps		3.9	3.9	3.9	3.9

SPECIFICATIONS

General Data		Model Number	CBA25UHV-042	CBA25UHV-048	CBA25UHV-060
		Nominal tonnage	3.5	4	5
Connections	Suction/Vapor line (o.d.) - in. sweat		7/8	7/8	7/8
	Liquid line (o.d.) - in. sweat		3/8	3/8	3/8
	Condensate - in. fpt		(2) 3/4	(2) 3/4	(2) 3/4
Indoor Coil	Net face area - ft. ²		5.66	6.13	7.08
	Tube outside diameter - in.		3/8	3/8	3/8
	Number of rows		3	3	3
	Fins per inch		15	15	15
Blower	Wheel nominal diameter x width - in.		10 x 8	12 x 10	12 x 10
	Blower motor output - hp		1	1	1
¹ Filters	Size of filter - in.		18 x 20 x 1	18 x 20 x 1	18 x 20 x 1
Shipping Data -1 package - lbs.			169	179	190

ELECTRICAL DATA

Voltage - 1 phase (60 Hz)		208/230V	208/230V	208/230V
² Maximum overcurrent protection (unit only)		15	15	15
³ Minimum circuit ampacity (unit only)		6.5	8.6	8.6
Blower Motor Full Load Amps		6.9	6.9	6.9

¹ Disposable filter.

² HACR type circuit breaker or fuse.

³ Refer to National or Canadian Electrical Code manual to determine wire, fuse and disconnect size requirements. Use wires suitable for at least 167°F.

OPTIONAL ACCESSORIES - ORDER SEPARATELY

Model	-018	-024 -030	-036	-042 -048 -060
iComfort® M30 Smart Wi-Fi Thermostat	15Z69	15Z69	15Z69	15Z69
Remote Outdoor Temperature Sensor	X2658	X2658	X2658	X2658
Downflow Conversion Kit	Y9658	Y9658	Y9659	Y9659
Electric Heat - See Electric Heat Data Tables	5 to 20 kW			
Horizontal Support Frame Kit	56J18	56J18	56J18	56J18
Side Return Unit Stand (Upflow Only)	45K32	45K32	45K32	45K32
Single-Point Power Source Control Box (for Electric Heat)	21H39	21H39	21H39	21H39
Wall Hanging Bracket Kit (Upflow Only)	45K30	45K30	45K30	45K30
High Performance Economizer (Commercial Only)	10U53	10U53	10U53	10U53

Model Number Identification

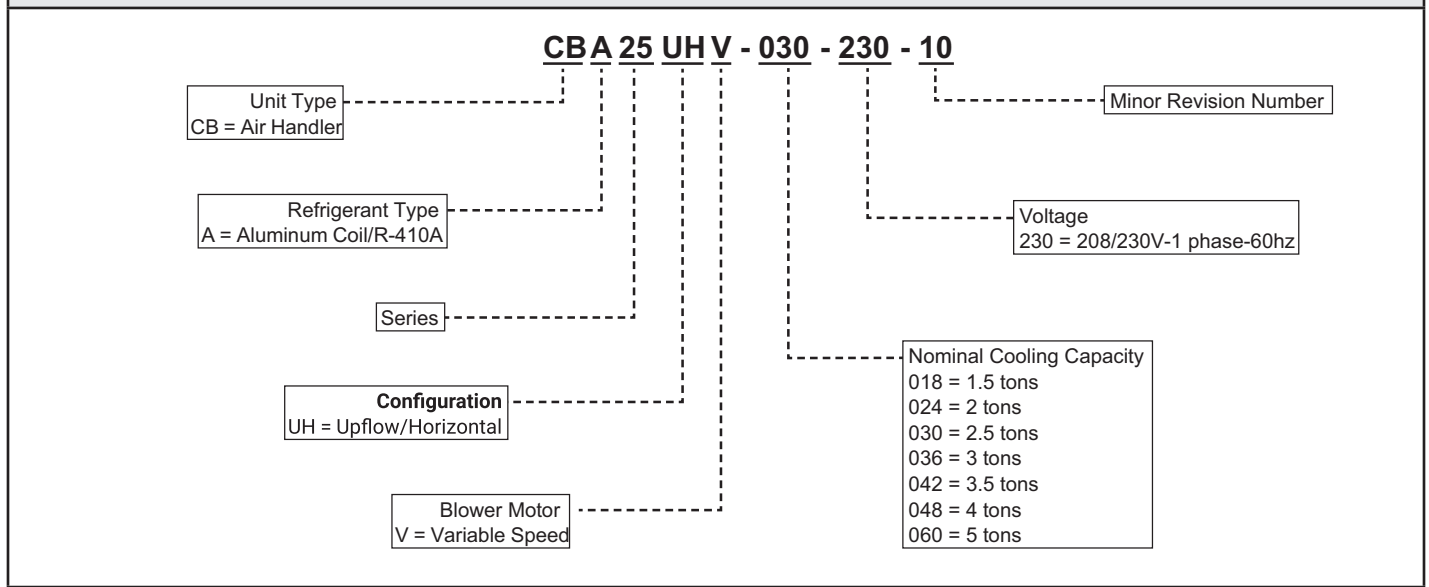

Adjusting the BDC3 Blower Control

⚠ WARNING

ELECTROSTATIC DISCHARGE (ESD)
Precautions and Procedures

Electrostatic discharge can affect electronic components. Take care during unit installation and service to protect the unit's electronic controls. Precautions will help to avoid control exposure to electrostatic discharge by putting the unit, the control and the technician at the same electrostatic potential. Touch hand and all tools on an unpainted unit surface before performing any service procedure to neutralize electrostatic charge.

Merit® CBA25UHV units are equipped with a variable-speed motor that is capable of maintaining a specified CFM throughout the external static range. A particular CFM can be obtained by positioning jumpers (**COOL**, **HEAT**, and **ADJUST**) on the BDC3 control.

The jumpers are labeled 1, 2, 3, and 4. This indicates the selected air volume (CFM). The **ADJUST** jumper is labeled Test, -, +, and Norm. The - and + pin settings are used to add or subtract a percentage of the CFM selected. The Test jumper is used to operate the motor in the test mode. The delay jumper controls the timing pattern in which the fan delay occurs.

Figure 1 illustrates the BDC3 control. Use tables on pages 5 and 6 to determine the correct air volume for heat and cool speed taps.

Diagnostic LEDs located on the BDC3 control to assist in servicing the unit. Read the jumper settings section before adjusting blower speed. Refer to page 5 for identification and information.

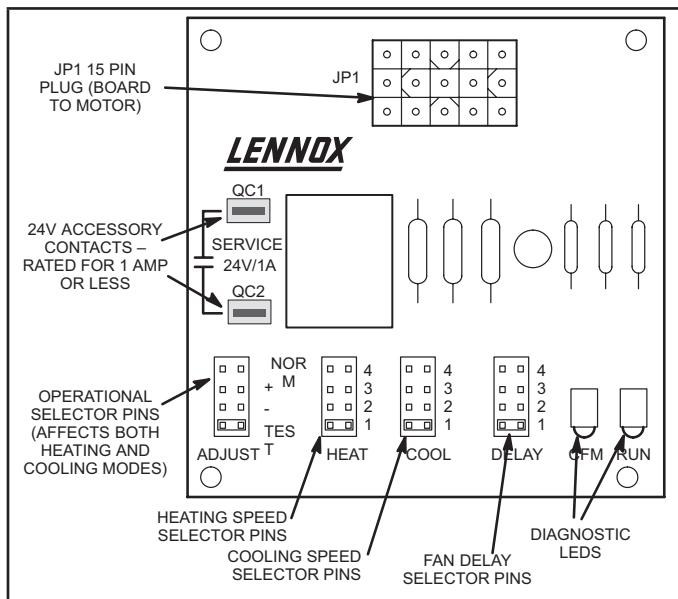

FIGURE 1. BDC3 Variable Speed Control Selections

Adjusting the Blower Speed

Diagnostic LEDs

- 1 - **RUN LED** indicates there is a demand for the blower motor to run.
- 2 - **CFM LED** indicates the cubic feet per minute at which the unit is operating. The light flashes once for approximately every 100 CFM. For example, if the unit is operating at 1000 CFM, CFM LED will flash 10 times. If the CFM is 1150, CFM LED will flash 11 full times plus one fast or half flash.

At times, the light may appear to flicker or glow. This is normal and occurs when the control is communicating with the motor between cycles.

Move the jumper pins to select the blower speed needed to meet application CFM requirements.

JUMPER SETTINGS

IMPORTANT

Before changing jumper setting, make sure the motor has completely stopped. Any jumper setting change will not take place while the motor is running.

Tables 1 and 2 list the recommended factory blower speed tap selections for Merit® CBA25UHV series units. These settings are for nominal tonnage match-ups with the Merit® CBA25UHV. When matched with other sizes, it is recommended that the CFM be adjusted to provide approximately 400 CFM per ton.

TABLE 1. Recommended Blower Speed Taps

Air Handler	Speed Tap Selection			
	Cooling		Heating*	
	Note 1 -	Note 2 -	Note 3 -	Note 4 -
CBA25UHV018	COOL PIN #2	COOL PIN #2	HEAT PIN #2	HEAT PIN #2
CBA25UHV024	COOL PIN #3	COOL PIN #3	HEAT PIN #3	HEAT PIN #3
CBA25UHV030	COOL PIN #3	COOL PIN #3	HEAT PIN #3	HEAT PIN #3
CBA25UHV036	COOL PIN #3	COOL PIN #3	HEAT PIN #3	HEAT PIN #3
CBA25UHV042	COOL PIN #3	COOL PIN #3	HEAT PIN #3	HEAT PIN #3
CBA25UHV048	COOL PIN #3	COOL PIN #3	HEAT PIN #3	HEAT PIN #3
CBA25UHV060	COOL PIN #3	COOL PIN #3	HEAT PIN #3	HEAT PIN #3
NOTES - 1 - Condensing Unit 2 - Heat Pump 3 - Condensing Unit with electric heat only 4 - Heat Pump with electric heat * <i>Minimum setting for heat</i>				

To change jumper positions, gently pull the jumper off the pins and insert it onto the desired set of pins. The following section outlines the different jumper selections available and conditions associated with each one as illustrated in table 2.

After the CFM for each application has been determined, the jumper settings must be adjusted to reflect those given in the appropriate tables on the following pages. From the tables, determine which row of CFM volumes most closely matches the desired CFM. Once a specific row has been chosen (+, NORMAL, or -), CFM volumes from other rows cannot be used. Below are descriptions of the jumper selections.

ADJUST JUMPER

The ADJUST pins allow the motor to run at normal speed, slightly higher (approximately 10%) than normal speed, or slightly lower (approximately 10%) than normal speed.

The tables on the following pages list three rows (+, NORMAL, and -) with their respective CFM volumes. Notice in table 2, for example, that the normal adjustment setting for heat speed position #4 is 1000 CFM. The + adjustment setting for that position is 1080 CFM and for the - adjustment setting is 910 CFM. After the adjustment setting has been determined, choose the remaining speed jumper settings from those offered in the table in that row.

The TEST pin is available to bypass the BDC3 control and run the motor at approximately 70% to test that the motor is operational. This is beneficial primarily in troubleshooting. G must be energized for motor to run.

COOL JUMPER

The **COOL** jumper is used to determine the CFM during either cooling or heat pump operation without a call for electric heat. These jumper selections are activated for cooling when Y2 and DS terminals in the Merit® CBA25UHV are energized. The are activated for heating when Y2 is energized.

Applications **without** the Lennox ComfortSense® 7500 thermostat will provide 70% of the **COOL** CFM during first-stage cooling for two-stage outdoor units. 100% of **COOL** speed is provided for systems with a single-stage outdoor unit.

Applications **with** the Lennox ComfortSense® 7500 thermostat, but no demand for de-humidification will operate as follows: during a first-stage cooling call (two-stage outdoor unit), the air volume is 70% of the **COOL** jumper selection. This arrangement provides for additional dehumidification during standard first-stage cooling. See the tables that follow for various scenarios concerning use of the ComfortSense® 7500 thermostat and the Merit® CBA25UHV series unit.

For applications with Harmony III® zone control, the air handler CFM volume is determined by the Harmony III control center. The minimum blower speed is predetermined at 250 CFM for -018, -024, -030 and -036 units and 450 CFM for -042, -048 and -060 units. This speed is not adjustable. See footnotes in the blower performance tables.

With the thermostat set for *Continuous Fan* and without a call for heating or cooling, the Merit® CBA25UHV provides 50% of the **COOL** CFM selected.

NOTE - For two-stage heat pumps, air handler will operate at 70% of the **COOL** selection until supplemental electric heat is demanded. At that time, the air handler will operate at the selected **HEAT** speed. This arrangement provides warmer supply air during second-stage heating.

TABLE 2

BLOWER DATA

CBA25UHV-018 BLOWER PERFORMANCE

0 through 0.80 in. w.g. External Static Pressure Range

"ADJUST" Jumper Setting	Jumper Speed Positions											
	"HEAT" Speed				First Stage "COOL" Speed				Second Stage "COOL" Speed			
	1	2	3	4	1	2	3	4	1	2	3	4
	cfm	cfm	cfm	cfm	cfm	cfm	cfm	cfm	cfm	cfm	cfm	cfm
+	500	705	925	1150	365	520	665	810	500	705	925	1150
NORM	465	650	850	1050	350	485	610	740	465	650	850	1050
-	420	600	760	950	320	425	560	680	420	600	760	950

NOTES - The effect of static pressure, filter and electric heater resistance is included in the air volumes listed.
 First stage cooling air volume is 70% of COOL speed setting. Continuous blower speed is approximately 50% of COOL speed setting.
 Lennox Harmony III™ Zoning System applications - minimum blower speed is 250 cfm.

BLOWER DATA

CBA25UHV-024 BLOWER PERFORMANCE

0 through 0.80 in. w.g. External Static Pressure Range

"ADJUST" Jumper Setting	Jumper Speed Positions											
	"HEAT" Speed				First Stage "COOL" Speed				Second Stage "COOL" Speed			
	1	2	3	4	1	2	3	4	1	2	3	4
	cfm	cfm	cfm	cfm	cfm	cfm	cfm	cfm	cfm	cfm	cfm	cfm
+	450	670	900	1120	340	450	650	770	450	670	900	1120
NORM	420	620	820	1050	300	400	600	700	420	620	820	1050
-	390	570	750	915	280	390	500	650	390	570	750	915

NOTES - The effect of static pressure, filter and electric heater resistance is included in the air volumes listed.
 First stage cooling air volume is 70% of COOL speed setting. Continuous blower speed is approximately 50% of COOL speed setting.
 Lennox Harmony III™ Zoning System applications - minimum blower speed is 250 cfm.

BLOWER DATA

CBA25UHV-030 BLOWER PERFORMANCE

0 through 0.80 in. w.g. External Static Pressure Range

"ADJUST" Jumper Setting	Jumper Speed Positions											
	"HEAT" Speed				First Stage "COOL" Speed				Second Stage "COOL" Speed			
	1	2	3	4	1	2	3	4	1	2	3	4
	cfm	cfm	cfm	cfm	cfm	cfm	cfm	cfm	cfm	cfm	cfm	cfm
+	680	885	1115	1340	490	635	770	930	680	885	1115	1340
NORM	620	810	1020	1220	440	575	715	845	620	810	1020	1220
-	550	725	905	1100	411	530	645	755	550	725	905	1100

NOTES - The effect of static pressure, filter and electric heater resistance is included in the air volumes listed.
 First stage cooling air volume is 70% of COOL speed setting. Continuous blower speed is approximately 50% of COOL speed setting.
 Lennox Harmony III™ Zoning System applications - minimum blower speed is 250 cfm.

BLOWER DATA

CBA25UHV-036 BLOWER PERFORMANCE

0 through 0.80 in. w.g. External Static Pressure Range

"ADJUST" Jumper Setting	Jumper Speed Positions											
	"HEAT" Speed				First Stage "COOL" Speed				Second Stage "COOL" Speed			
	1	2	3	4	1	2	3	4	1	2	3	4
	cfm	cfm	cfm	cfm	cfm	cfm	cfm	cfm	cfm	cfm	cfm	cfm
+	930	1155	1390	1530	640	815	970	1150	930	1155	1390	1530
NORM	830	1050	1260	1450	590	725	875	1025	830	1050	1260	1450
-	740	940	1135	1330	545	650	780	910	740	940	1135	1330

NOTES - The effect of static pressure, filter and electric heater resistance is included in the air volumes listed.

First stage cooling air volume is 70% of COOL speed setting. Continuous blower speed is approximately 50% of COOL speed setting.
Lennox Harmony III™ Zoning System applications - minimum blower speed is 250 cfm.

BLOWER DATA

CBA25UHV-042 BLOWER PERFORMANCE

0 through 0.80 in. w.g. External Static Pressure Range

"ADJUST" Jumper Setting	Jumper Speed Positions											
	"HEAT" Speed				First Stage "COOL" Speed				Second Stage "COOL" Speed			
	1	2	3	4	1	2	3	4	1	2	3	4
	cfm	cfm	cfm	cfm	cfm	cfm	cfm	cfm	cfm	cfm	cfm	cfm
+	1130	945	1575	1810	780	945	1110	1275	1130	945	1575	1810
NORM	1020	1255	1440	1650	710	860	1000	1160	1020	1255	1440	1650
-	920	1135	1300	1490	670	780	910	1040	920	1135	1300	1490

NOTES - The effect of static pressure, filter and electric heater resistance is included in the air volumes listed.

First stage cooling air volume is 70% of COOL speed setting. Continuous blower speed is approximately 50% of COOL speed setting.
Lennox Harmony III™ Zoning System applications - minimum blower speed is 450 cfm.

BLOWER DATA

CBA25UHV-048 BLOWER PERFORMANCE

0 through 0.80 in. w.g. External Static Pressure Range

"ADJUST" Jumper Setting	Jumper Speed Positions											
	"HEAT" Speed				First Stage "COOL" Speed				Second Stage "COOL" Speed			
	1	2	3	4	1	2	3	4	1	2	3	4
	cfm	cfm	cfm	cfm	cfm	cfm	cfm	cfm	cfm	cfm	cfm	cfm
+	1375	1600	1820	2185	960	1125	1285	1620	1375	1600	1820	2185
NORM	1260	1455	1655	2085	885	1035	1185	1475	1260	1455	1655	2085
-	1125	1310	1490	1885	790	925	1060	1330	1125	1310	1490	1885

NOTES - The effect of static pressure, filter and electric heater resistance is included in the air volumes listed.

First stage cooling air volume is 70% of COOL speed setting. Continuous blower speed is approximately 50% of COOL speed setting.
Lennox Harmony III™ Zoning System applications - minimum blower speed is 450 cfm.

BLOWER DATA

CBA25UHV-060 BLOWER PERFORMANCE

0 through 0.80 in. w.g. External Static Pressure Range

"ADJUST" Jumper Setting	Jumper Speed Positions											
	"HEAT" Speed				First Stage "COOL" Speed				Second Stage "COOL" Speed			
	1	2	3	4	1	2	3	4	1	2	3	4
	cfm	cfm	cfm	cfm	cfm	cfm	cfm	cfm	cfm	cfm	cfm	cfm
+	1600	1835	2030	2190	1110	1285	1380	1615	1600	1835	2030	2190
NORM	1465	1675	1855	2085	1000	1160	1250	1470	1465	1675	1855	2085
-	1320	1500	1675	1890	895	1035	1115	1320	1320	1500	1675	1890

NOTES - The effect of static pressure, filter and electric heater resistance is included in the air volumes listed.

First stage cooling air volume is 70% of COOL speed setting. Continuous blower speed is approximately 50% of COOL speed setting.
Lennox Harmony III™ Zoning System applications - minimum blower speed is 450 cfm.

TABLE 3. CBA25UHV Thermostat and Single-Stage Outdoor Unit Operating Sequence

Operating Sequence		System Demand								System Response		
System Condition	Step	Thermostat Demand						Relative Humidity		Com-pressor	Air Handler CFM (COOL)	Comments
		Y1	Y2	O	G	W1	W2	Status	D			
NO CALL FOR DEHUMIDIFICATION												
Normal Operation	1	On		On	On			Acceptable	24 VAC	High	100%	Compressor and indoor air handler follow thermostat demand
BASIC MODE (only active on a Y1 thermostat demand)												
Normal Operation	1	On		On	On			Acceptable	24 VAC	High	100%	Thermostat energizes Y1 and de-energizes D on a call for dehumidification
Dehumidification Call	2	On		On	On			Demand	0 VAC	High	60%/65% 70%*	
PRECISION MODE (operates independent of a Y1 thermostat demand)												
Normal Operation	1	On		On	On			Acceptable	24 VAC	High	100%	Dehumidification mode begins when humidity is greater than set point
Dehumidification Call	2	On		On	On			Demand	0 VAC	High	60%/65% 70%*	
Dehumidification Call ONLY	1	On		On	On			Demand	0 VAC	High	60%/65% 70%*	Thermostat will try to maintain room humidity setpoint by allowing the room space to maintain a cooler room thermostat setpoint**
Jumpers at indoor unit with a single stage outdoor unit With Condensing unit - Y1 to Y2 and R to O With Heat Pump - Y1 to Y2												
* During dehumidification, cooling air handler speed is as follows: 70% of COOL cfm for 018, 024, 030; 65% for 036; 60% for 042, 048 and 060 units. ** Thermostat will maintain the room temperature up to 2°F (1.2°C) cooler than the room thermostat setting in precision mode.												

TABLE 4. CBA25UHV Thermostat and Two-Stage Outdoor Unit Operating Sequence

Operating Sequence		System Demand								System Response		
System Condition	Step	Thermostat Demand						Relative Humidity		Com-pressor	Air Handler CFM (COOL)	Comments
		Y1	Y2	O	G	W1	W2	Status	D			
NO CALL FOR DEHUMIDIFICATION												
Normal Operation - Y1	1	On		On	On			Acceptable	24 VAC	Low	70%	Compressor and indoor air handler follow thermostat demand
Normal Operation - Y2	2	On	On	On	On			Acceptable	24 VAC	High	100%	
Room Thermostat Calls for First-Stage Cooling												
BASIC MODE (only active on a Y1 thermostat demand)												
Normal Operation	1	On		On	On			Acceptable	24 VAC	Low	70%	Thermostat energizes Y2 and de-energizes D on a call for dehumidification
Dehumidification Call	2	On	On	On	On			Demand	24 VAC	High	60%/65% 70%*	
PRECISION MODE (operates independent of a Y1 thermostat demand)												
Normal Operation	1	On		On	On			Acceptable	24 VAC	Low	70%	Dehumidification mode begins when humidity is greater than set point
Dehumidification Call	2	On	On	On	On			Demand	0 VAC	High	60%/65% 70%*	
Dehumidification Call ONLY	1	On	On	On	On			Demand	0 VAC	High	60%/65% 70%*	Thermostat will try to maintain room humidity setpoint by allowing the room space to maintain a cooler room thermostat setpoint**
Room Thermostat Calls for First- and Second-Stage Cooling												
BASIC MODE (only active on a Y1 thermostat demand)												
Normal Operation	1	On	On	On	On			Acceptable	24 VAC	High	100%	Thermostat energizes Y2 and de-energizes D on a call for dehumidification
Dehumidification Call	2	On	On	On	On			Demand	0 VAC	High	60%/65% 70%*	
PRECISION MODE (operates independent of a Y1 thermostat demand)												
Normal Operation	1	On	On	On	On			Acceptable	24 VAC	High	100%	Dehumidification mode begins when humidity is greater than set point
Dehumidification Call	2	On	On	On	On			Demand	0 VAC	High	60%/65% 70%*	
Dehumidification Call ONLY	1	On	On	On	On			Demand	0 VAC	High	60%/65% 70%*	Thermostat will try to maintain room humidity setpoint by allowing the room space to maintain a cooler room thermostat setpoint**
Jumpers at indoor unit with a two-stage outdoor unit With Condensing unit - Y2 and R to O With Heat Pump - none												
* During dehumidification, cooling air handler speed is as follows: 70% of COOL cfm for 018, 024, 030; 65% for 036; 60% for 042, 048 and 060 units. ** Thermostat will maintain the room temperature up to 2°F (1.2°C) cooler than the room thermostat setting in precision mode.												

HEAT JUMPER

The **HEAT** jumper is used to determine CFM during electric heat operation only. These jumper selections are activated only when W1 is energized.

DELAY JUMPER

The **DELAY** jumper is used to set the specific motor fan operation during cooling mode. Depending on the application, one of four options may be chosen by moving the jumper to the appropriate set of pins.

#1 Pins Jumpered

- A- Motor runs at 100% until demand is satisfied.
- B- Once demand is met, motor ramps down to stop.

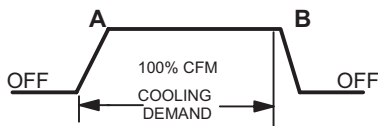

#2 Pins Jumpered

- A- Motor runs at 100% until demand is satisfied.
- B- Once demand is met, motor runs at 100% for 60 seconds.

C- Motor ramps down to stop.

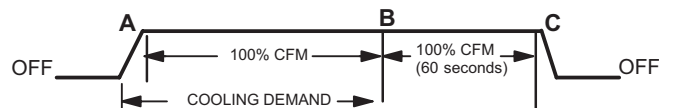

#3 Pins Jumpered

- A- Motor runs at 82% for approximately 7-1/2 minutes. If demand has not been satisfied after 7-1/2 minutes.
- B- Motor runs at 100% until demand is satisfied.
- C- Once demand is met, motor ramps down to stop.

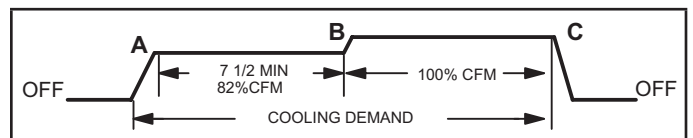

#4 Pins Jumpered

- A- Motor runs at 50% for 30 seconds.
- B- Motor then runs at 82% for approximately 7-1/2 minutes. If demand has not been satisfied after 7-1/2 minutes,
- C- Motor runs at 100% until demand is satisfied.

D- Once demand is met, motor runs at 50% for 30 seconds.

E- Motor ramps down to stop.

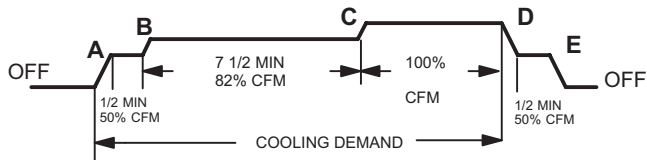

Application

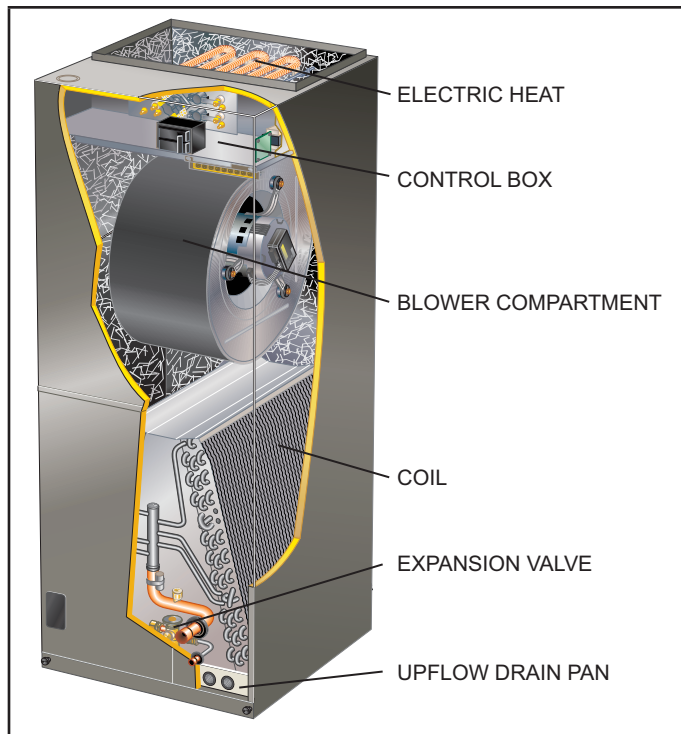

FIGURE 2. Typical Unit Parts Arrangement

All major blower coil components must be matched according to Lennox recommendations for the unit to be covered under warranty. Refer to the Product Specification bulletin for approved system matchups. A misapplied system will cause erratic operation and can result in early unit failure.

The units come with factory installed check and expansion valve for all applications. The TXV valve has been installed internally for a cleaner installation and is accessible if required.

Unit Components

CONTROL BOX

The CBA25UHV control box is located above the blower section shown in figure 2. Line voltage and electric heat connections are made in the control box. Optional electric heat fits through an opening located in the center of the control box. When electric heat is not used, cover plates cover the opening. The electric heat control arrangement is detailed in the electric heat section of this manual.

TRANSFORMER

All CBA25UHV series units use a single line voltage to 24VAC transformer mounted in the control box. The transformer supplies power to the control circuits in the indoor and outdoor unit. Transformers are rated at 40VA. 208/240VAC single phase transformers use two primary voltage taps as shown in figure 3.

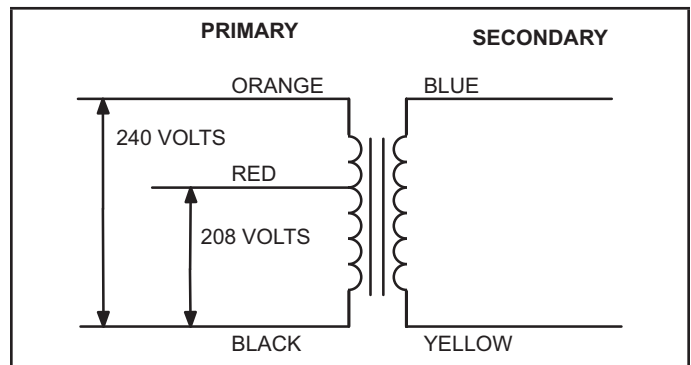

FIGURE 3. 208 / 240 Volt Transformer

BLOWER RELAY

All CBA25UHV units use a double-pole single-throw (DPST) switch relay to energize the blower motor. The relay coil is energized by blower demand from indoor thermostat. When the coil is energized, a set of normally open (N.O.) contacts closes to energize the blower motor on cooling speed. When de-energized, a set of normally closed (N.C.) contacts allows the electric heat relay to energize the blower on heating speed (refer to unit wiring diagram).

BLOWER MOTOR (B3)

CBA25UHV -018, -024, -030, -036 and -048 units use single-phase direct drive blower motors. Figure 4 shows the parts arrangement.

All units are factory wired for heat pump and cooling applications with or without electric heat. The unit wiring diagrams will provide factory set blower speeds.

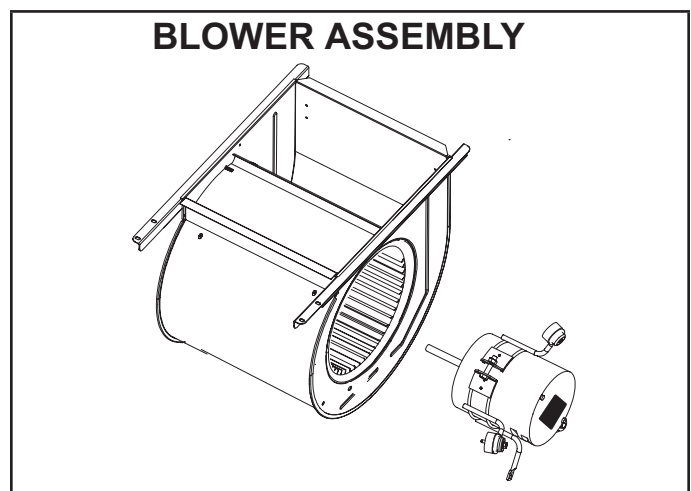

FIGURE 4. Blower Assembly

COIL

CBA25UHV units have dual slab coils arranged in an A configuration. Each coil has two or three rows of aluminum tubes fitted with ripple-edged aluminum fins. An expansion valve feeds multiple parallel circuits through the coils. The coil is designed to easily slide out of the unit cabinet.

PLASTIC DRAIN PANS

Drain pans are provided and installed on the CBA25UHV. The drain pans are made from fiberglass filled plastic.

ECBA25 Electric Heat Data

ELECTRIC HEAT DATA CBA25UHV-018 | SINGLE PHASE

	Electric Heat Model Number	Input			Blower Motor Full Load Amps	² Minimum Circuit Ampacity	³ Maximum Overcurrent Protection
		Volt	kW	¹ Btuh			
5 kW	ECBA25-5 (16Y36) Terminal Block ECBA25-5CB (16Y39) 30A Circuit Breaker	208	3.6	12,300	3.9	27	30
		220	4.0	13,800	3.9	28	30
		230	4.4	15,000	3.9	29	30
		240	4.8	16,400	3.9	30	30
7.5 kW	ECBA25-7.5 (16Y37) Terminal Block ECBA25-7.5CB (16Y41) 45A Circuit Breaker	208	5.6	19,200	3.9	39	⁴ 40
		220	6.3	21,500	3.9	41	45
		230	6.9	23,500	3.9	42	45
		240	7.5	25,600	3.9	44	45
10 kW	ECBA25-10 (16Y38) Terminal Block ECBA25-10CB (16Y42) 60A Circuit Breaker	208	7.2	24,600	3.9	48	⁴ 50
		220	8.0	27,500	3.9	51	60
		230	8.8	30,000	3.9	53	60
		240	9.6	32,700	3.9	55	60

ELECTRIC HEAT DATA CBA25UHV-024 | SINGLE PHASE

	Electric Heat Model Number	Input			Blower Motor Full Load Amps	² Minimum Circuit Ampacity	³ Maximum Overcurrent Protection
		Volt	kW	¹ Btuh			
5 kW	ECBA25-5 (16Y36) Terminal Block ECBA25-5CB (16Y39) 30A Circuit Breaker	208	3.6	12,300	3.9	27	30
		220	4.0	13,800	3.9	28	30
		230	4.4	15,000	3.9	29	30
		240	4.8	16,400	3.9	30	30
7.5 kW	ECBA25-7.5 (16Y37) Terminal Block ECBA25-7.5CB (16Y41) 45A Circuit Breaker	208	5.6	19,200	3.9	39	⁴ 40
		220	6.3	21,500	3.9	41	45
		230	6.9	23,500	3.9	42	45
		240	7.5	25,600	3.9	44	45
10 kW	ECBA25-10 (16Y38) Terminal Block ECBA25-10CB (16Y42) 60A Circuit Breaker	208	7.2	24,600	3.9	48	⁴ 50
		220	8.0	27,500	3.9	51	60
		230	8.8	30,000	3.9	53	60
		240	9.6	32,700	3.9	55	60

NOTE - Circuit 1 Minimum Circuit Ampacity includes the Blower Motor Full Load Amps.

¹ Electric heater capacity only - does not include additional blower motor heat capacity.

² Refer to National or Canadian Electrical Code manual to determine wire, fuse and disconnect size requirements. Use wires suitable for at least 167°F.

³ HACR type breaker or fuse.

⁴ **Bold indicates that the circuit breaker on "CB" circuit breaker models must be replaced with size shown.**

ELECTRIC HEAT DATA

CBA25UHV-030 | SINGLE PHASE

Electric Heat Model Number	Input			Blower Motor Full Load Amps	² Minimum Circuit Ampacity		³ Maximum Overcurrent Protection		Single Point Power Source	
	Volt	kW	¹ Btuh		Ckt 1	Ckt 2	Ckt 1	Ckt 2	² Minimum Circuit Ampacity	³ Maximum Overcurrent Protection
5 kW ECBA25-5 (16Y36) Terminal Block ECBA25-5CB (16Y39) 30A Circuit Breaker	208	3.6	12,300	3.9	27	---	30	---	---	---
	220	4.0	13,800	3.9	28	---	30	---	---	---
	230	4.4	15,000	3.9	29	---	30	---	---	---
	240	4.8	16,400	3.9	30	---	30	---	---	---
7.5 kW ECBA25-7.5 (16Y37) Terminal Block ECBA25-7.5CB (16Y41) 45A Circuit Breaker	208	5.6	19,200	3.9	39	---	⁴ 40	---	---	---
	220	6.3	21,500	3.9	41	---	45	---	---	---
	230	6.9	23,500	3.9	42	---	45	---	---	---
	240	7.5	25,600	3.9	44	---	45	---	---	---
10 kW ECBA25-10 (16Y38) Terminal Block ECBA25-10CB (16Y42) 60A Circuit Breaker	208	7.2	24,600	3.9	48	---	50	---	---	---
	220	8.0	27,500	3.9	51	---	60	---	---	---
	230	8.8	30,000	3.9	53	---	60	---	---	---
	240	9.6	32,700	3.9	55	---	60	---	---	---
12.5 kW ECBA25-12.5CB (16Y43) (1) 50A and (1) 25A Circuit Breaker	208	9.4	32,000	3.9	42	19	⁴ 45	⁴ 20	61	70
	220	10.5	35,800	3.9	45	20	⁴ 45	⁴ 20	65	70
	230	11.5	39,200	3.9	46	21	50	25	67	70
	240	12.5	42,600	3.9	48	22	50	25	70	70
15 kW ECBA25-15CB (16Y44) (1) 60A and (1) 25A Circuit Breaker	208	10.8	36,900	3.9	48	22	⁴ 50	25	70	70
	220	12.1	41,300	3.9	51	23	60	25	74	80
	230	13.2	45,100	3.9	53	24	60	25	77	80
	240	14.4	49,100	3.9	55	25	60	25	80	80

NOTE - Circuit 1 Minimum Circuit Ampacity includes the Blower Motor Full Load Amps.

¹ Electric heater capacity only - does not include additional blower motor heat capacity.

² Refer to National or Canadian Electrical Code manual to determine wire, fuse and disconnect size requirements. Use wires suitable for at least 167°F.

³ HACR type breaker or fuse.

⁴ Bold indicates that the circuit breaker on "CB" circuit breaker models must be replaced with size shown.

ELECTRIC HEAT DATA

CBA25UHV-036 | SINGLE PHASE

Electric Heat Model Number	Input			Blower Motor Full Load Amps	² Minimum Circuit Ampacity		³ Maximum Overcurrent Protection		Single Point Power Source	
	Volt	kW	¹ Btuh		Ckt 1	Ckt 2	Ckt 1	Ckt 2	² Minimum Circuit Ampacity	³ Maximum Overcurrent Protection
5 kW ECBA25-5 (16Y36) Terminal Block ECBA25-5CB (16Y39) 30A Circuit Breaker	208	3.6	12,300	3.9	27	---	30	---	---	---
	220	4.0	13,800	3.9	28	---	30	---	---	---
	230	4.4	15,000	3.9	29	---	30	---	---	---
	240	4.8	16,400	3.9	30	---	30	---	---	---
7.5 kW ECBA25-7.5 (16Y37) Terminal Block ECBA25-7.5CB (16Y41) 45A Circuit Breaker	208	5.6	19,200	3.9	39	---	⁴ 40	---	---	---
	220	6.3	21,500	3.9	41	---	45	---	---	---
	230	6.9	23,500	3.9	42	---	45	---	---	---
	240	7.5	25,600	3.9	44	---	45	---	---	---
10 kW ECBA25-10 (16Y38) Terminal Block ECBA25-10CB (16Y42) 60A Circuit Breaker	208	7.2	24,600	3.9	48	---	⁴ 50	---	---	---
	220	8.0	27,500	3.9	51	---	60	---	---	---
	230	8.8	30,000	3.9	53	---	60	---	---	---
	240	9.6	32,700	3.9	55	---	60	---	---	---
12.5 kW ECBA25-12.5CB (16Y43) (1) 50A and (1) 25A Circuit Breaker	208	9.4	32,000	3.9	42	19	⁴ 45	⁴ 20	61	70
	220	10.5	35,800	3.9	45	20	⁴ 45	⁴ 20	65	70
	230	11.5	39,200	3.9	46	21	50	25	67	70
	240	12.5	42,600	3.9	48	22	50	25	70	70
15 kW ECBA25-15CB (16Y44) (1) 60A and (1) 25A Circuit Breaker	208	10.8	36,900	3.9	48	22	⁴ 50	25	70	70
	220	12.1	41,300	3.9	51	23	60	25	74	80
	230	13.2	45,100	3.9	53	24	60	25	77	80
	240	14.4	49,100	3.9	55	25	60	25	80	80

NOTE - Circuit 1 Minimum Circuit Ampacity includes the Blower Motor Full Load Amps.

¹ Electric heater capacity only - does not include additional blower motor heat capacity.

² Refer to National or Canadian Electrical Code manual to determine wire, fuse and disconnect size requirements. Use wires suitable for at least 167°F.

³ HACR type breaker or fuse.

⁴ Bold indicates that the circuit breaker on "CB" circuit breaker models must be replaced with size shown.

ELECTRIC HEAT DATA

CBA25UHV-042 | SINGLE PHASE

Electric Heat Model Number	Input			Blower Motor Full Load Amps	² Minimum Circuit Ampacity		³ Maximum Overcurrent Protection		Single Point Power Source	
	Volt	kW	¹ Btuh		Ckt 1	Ckt 2	Ckt 1	Ckt 2	² Minimum Circuit Ampacity	³ Maximum Overcurrent Protection
5 kW ECBA25-5 (16Y36) Terminal Block ECBA25-5CB (16Y39) 30A Circuit Breaker	208	3.6	12,300	6.9	30	---	30	---	---	---
	220	4.0	13,800	6.9	32	---	⁴ 35	---	---	---
	230	4.4	15,000	6.9	33	---	⁴ 35	---	---	---
	240	4.8	16,400	6.9	34	---	⁴ 35	---	---	---
7.5 kW ECBA25-7.5 (16Y37) Terminal Block ECBA25-7.5CB (16Y41) 45A Circuit Breaker	208	5.6	19,200	6.9	42	---	45	---	---	---
	220	6.3	21,500	6.9	44	---	45	---	---	---
	230	6.9	23,500	6.9	46	---	⁴ 50	---	---	---
	240	7.5	25,600	6.9	48	---	⁴ 50	---	---	---
10 kW ECBA25-10 (16Y38) Terminal Block ECBA25-10CB (16Y42) 60A Circuit Breaker	208	7.2	24,600	6.9	52	---	60	---	---	---
	220	8.0	27,500	6.9	54	---	60	---	---	---
	230	8.8	30,000	6.9	57	---	60	---	---	---
	240	9.6	32,700	6.9	59	---	60	---	---	---
12.5 kW ECBA25-12.5CB (16Y43) (1) 50A and (1) 25A Circuit Breaker	208	9.4	32,000	6.9	46	19	50	⁴ 20	65	70
	220	10.5	35,800	6.9	48	20	50	⁴ 20	68	70
	230	11.5	39,200	6.9	50	21	50	25	71	80
	240	12.5	42,600	6.9	52	22	⁴ 60	25	74	80
15 kW ECBA25-15CB (16Y44) (1) 60A and (1) 25A Circuit Breaker	208	10.8	36,900	6.9	52	22	60	25	74	80
	220	12.1	41,300	6.9	54	23	60	25	77	80
	230	13.2	45,100	6.9	57	24	60	25	80	80
	240	14.4	49,100	6.9	59	25	60	25	84	90

NOTE - Circuit 1 Minimum Circuit Ampacity includes the Blower Motor Full Load Amps.

¹ Electric heater capacity only - does not include additional blower motor heat capacity.

² Refer to National or Canadian Electrical Code manual to determine wire, fuse and disconnect size requirements. Use wires suitable for at least 167°F.

³ HACR type breaker or fuse.

⁴ **Bold indicates that the circuit breaker on "CB" circuit breaker models must be replaced with size shown.**

ELECTRIC HEAT DATA

CBA25UHV-048 | CBA25UHV-060 | SINGLE PHASE

Electric Heat Model Number	Input			Blower Motor Full Load Amps	² Minimum Circuit Ampacity		³ Maximum Overcurrent Protection		Single Point Power Source	
	Volt	kW	¹ Btuh		Ckt 1	Ckt 2	Ckt 1	Ckt 2	² Minimum Circuit Ampacity	³ Maximum Overcurrent Protection
5 kW ECBA25-5 (16Y36) Terminal Block ECBA25-5CB (16Y39) 30A Circuit Breaker	208	3.6	12,300	6.9	30	---	30	---	---	---
	220	4.0	13,800	6.9	32	---	⁴ 35	---	---	---
	230	4.4	15,000	6.9	33	---	⁴ 35	---	---	---
	240	4.8	16,400	6.9	34	---	⁴ 35	---	---	---
7.5 kW ECBA25-7.5 (16Y37) Terminal Block ECBA25-7.5CB (16Y41) 45A Circuit Breaker	208	5.6	19,200	6.9	42	---	45	---	---	---
	220	6.3	21,500	6.9	44	---	45	---	---	---
	230	6.9	23,500	6.9	46	---	⁴ 50	---	---	---
	240	7.5	25,600	6.9	48	---	⁴ 50	---	---	---
10 kW ECBA25-10 (16Y38) Terminal Block ECBA25-10CB (16Y42) 60A Circuit Breaker	208	7.2	24,600	6.9	52	---	60	---	---	---
	220	8.0	27,500	6.9	54	---	60	---	---	---
	230	8.8	30,000	6.9	57	---	60	---	---	---
	240	9.6	32,700	6.9	59	---	60	---	---	---
12.5 kW ECBA25-12.5CB (16Y43) (1) 50A and (1) 25A Circuit Breaker	208	9.4	32,000	6.9	46	19	50	⁴ 20	65	70
	220	10.5	35,800	6.9	48	20	50	⁴ 20	68	70
	230	11.5	39,200	6.9	50	21	50	25	71	80
	240	12.5	42,600	6.9	52	22	⁴ 60	25	74	80
15 kW ECBA25-15CB (16Y44) (1) 60A and (1) 25A Circuit Breaker	208	10.8	36,900	6.9	52	22	60	25	74	80
	220	12.1	41,300	6.9	54	23	60	25	77	80
	230	13.2	45,100	6.9	57	24	60	25	80	80
	240	14.4	49,100	6.9	59	25	60	25	84	90
20 kW ECBA25-20CB (16Y46) (1) 60A and (1) 50A Circuit Breaker	208	14.4	49,200	6.9	52	43	60	⁴ 45	95	100
	220	16.1	55,000	6.9	54	46	60	50	100	100
	230	17.6	60,100	6.9	57	48	60	50	104	110
	240	19.2	65,500	6.9	59	50	60	50	109	110

NOTE - Circuit 1 Minimum Circuit Ampacity includes the Blower Motor Full Load Amps.

¹ Electric heater capacity only - does not include additional blower motor heat capacity.

² Refer to National or Canadian Electrical Code manual to determine wire, fuse and disconnect size requirements. Use wires suitable for at least 167°F.

³ HACR type breaker or fuse.

⁴ Bold indicates that the circuit breaker on "CB" circuit breaker models must be replaced with size shown. See tablepage 6.

Heat Section Installation

⚠ WARNING



Before installing or servicing unit, be sure ALL power to the unit is OFF. More than one disconnect switch may be present. *Electrical shock can cause personal injury or death!*

Before installing the unit, check information on the unit rating plate to ensure that the unit meets the job specification, proper electrical power is available, and that proper duct clearances are maintained.

NOTE – If installing heat sections at the same time as the air handler unit, install the electric heat section in the air handler unit before setting the air handler unit and attaching the plenum.

- 1 - Shut off all power to the air handler unit. More than one disconnect may be required.
- 2 - Remove air handler access panel and keep the six screws to reattach access panel after installing heat elements.
- 3 - Disconnect any existing field supply wires and pull them out of the air handler. Disconnect and remove wiring harness and fastener (see figure 5). If not removed, these items will prevent the heat section's base from resting properly in the compartment.
- 4 - Remove the no-heat seal plate in the air handler frame (see figure 5).

NOTE – If a small heater is installed in the unit, the installer will need to remove the no-heat plate and break it apart at the perforations and reinstall the two pieces so the smaller heater can be installed into the unit.

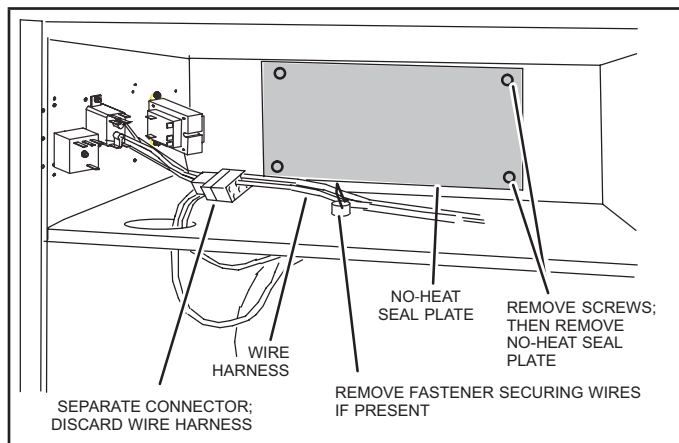

FIGURE 5. Prepare to Install Heat Element

- 5 - Slide the electric heat section into the air handler. Be careful that the heating elements do not rub against the sheet metal opening when they slide into the air handler. The mounting holes should then line up with holes in the air handler control box.

- 6 - Secure the electric heater assembly into place with the screws that were removed from the heat element panel. Install two field-provided #8 SDST screws in the front of the electric heater assembly (see figure 6).

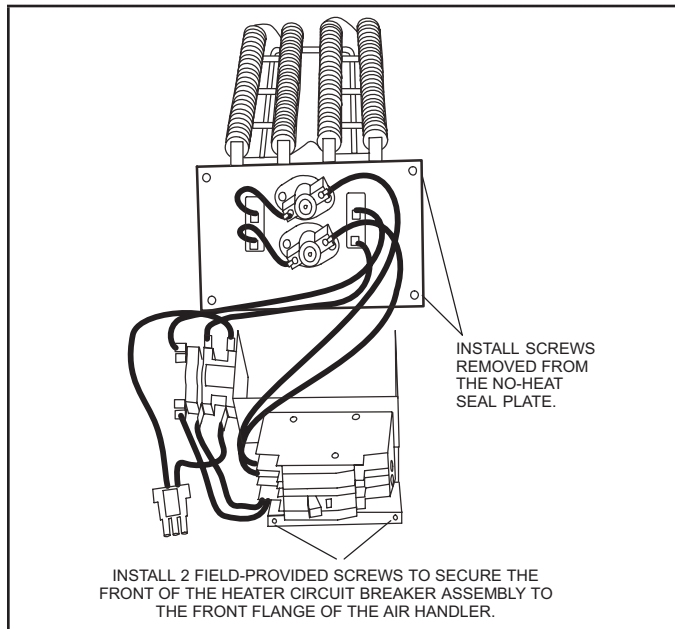

FIGURE 6. Installing the Heat Element Assembly

- 7 - The air handler's access panels have a cover plate that is fastened with a screw and will need to be positioned to fit either one breaker or two, but do not install the access panel until all electrical connections have been completed.

⚠ WARNING

Foil face insulation must be cut to eliminate the possibility for any frayed foil to come in contact with any main or low voltage connections. Insulation must be kept a minimum of 1/2" away from any electrical connection.

CHANGING CIRCUIT BREAKER ORIENTATION

The air handler comes from the factory ready for horizontal right hand discharge installation. Always rotate the breaker so up is the ON position in all orientations. The circuit breaker orientation change is required by UL 1995, Article 26.18 (25 September 2005).

- 1 - Locate the one clip located on the right side (see arrow) of each breaker (see figure 8). The clip secures the circuit breaker to the mounting bracket. Pull the clip to release the breaker from the mounting bracket and rotate the breaker to the proper position.

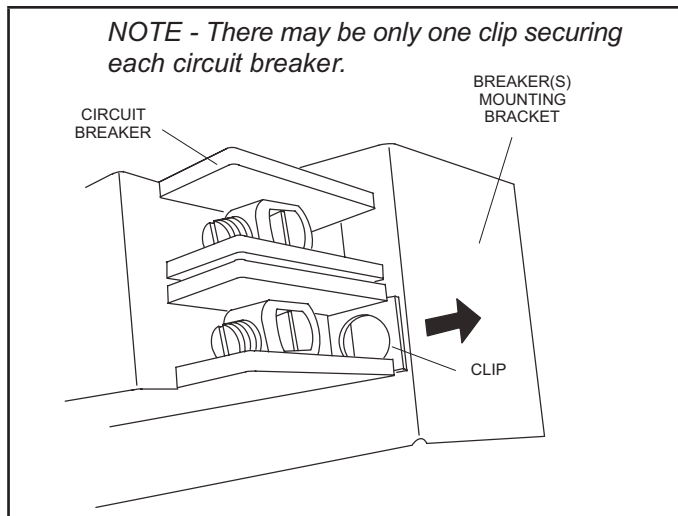

FIGURE 7. Circuit Breaker Clip

2 - Install the circuit breaker cover plate.

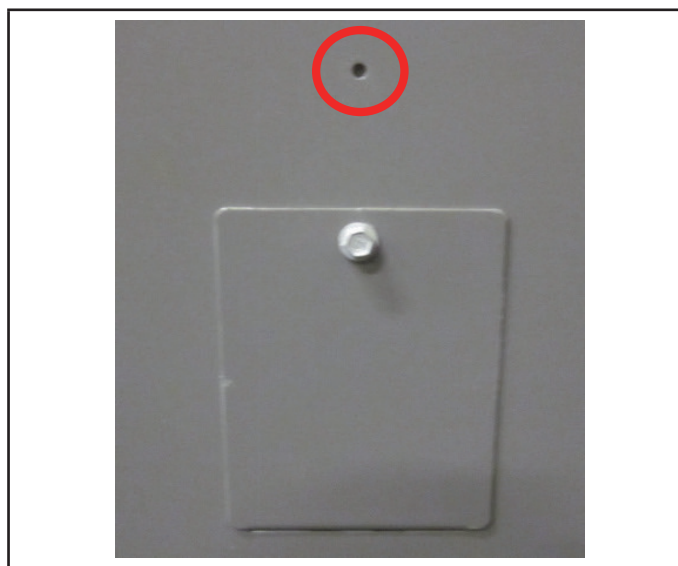

FIGURE 8. Circuit Breaker Cover Plate

NOTE – If electric heat kit has only one circuit breaker, the breaker cover plate needs to be moved up and installed over the opening without the circuit breaker. Fasten the breaker cover plate to the access panel using the circled hole in figure 8. If the electric heat kit has two circuit breakers, the breaker cover plate is not required.

Electrical Connections

⚠ WARNING



Electric shock hazard! - Disconnect all power supplies before servicing.

Replace all parts and panels before operating.

Failure to do so can result in death or electrical shock.

⚠ IMPORTANT USE COPPER CONDUCTORS ONLY

NOTE – Refer to the nameplate on the air handler unit for minimum circuit ampacity and maximum overcurrent protection size.

The air handler units are provided with openings to be used with 1-1/2 inch trade size (1-31/32 inch diameter) conduit.

If you want a single point power supply, refer to the nameplate on the single point power supply accessory for minimum circuit ampacity and maximum overcurrent protection size. Select the proper supply circuit conductors in accordance with tables 310-16 and 310-17 in the National Electric Code, ANSI/NFPA No. 70 or tables 1 through 4 in the Canadian Electric Code, Part I, CSA Standard C22.1.

Refer to figure 25 for typical low voltage field wiring for air handler/condensing unit and heat pump applications. Figure 24 is a diagram of the air handler connections and the heater high-voltage wiring.

- 1 - Make wiring connections as follows:
Heaters equipped with circuit breakers – Connect field power supply wiring to circuit breaker(s). Figure 9 shows **L1**, **L2** and ground (**GND**) connections for a 2-breaker configuration.

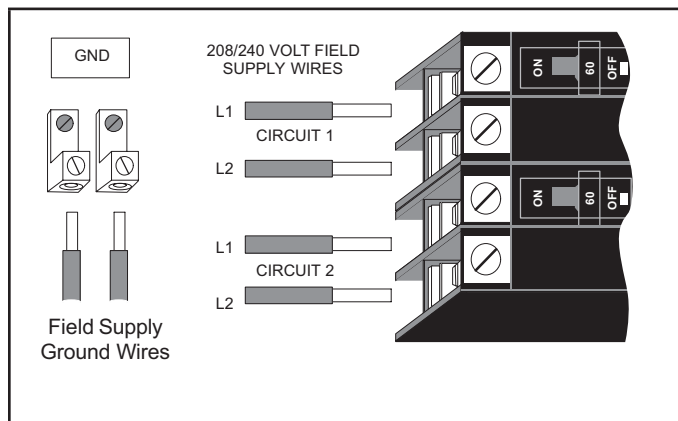

FIGURE 9. Field Power Supply Wiring

- 2 - Remove the interface harness from the air handler unit and connect the 6-pin connector on the heater assembly to the mating connector on the air handler unit.
- 3 - For applications using a two-stage room thermostat and/or an outdoor thermostat, connect wiring as shown in figure 24.

Circuit Breaker Cover Installation

- 1 - Remove any installed patch plates still present.
- 2 - Remove paper backing from the adhesive around the perimeter of the back side of the circuit breaker cover (figure 10).
- 3 - Position the breaker cover over the air handler circuit breaker opening.

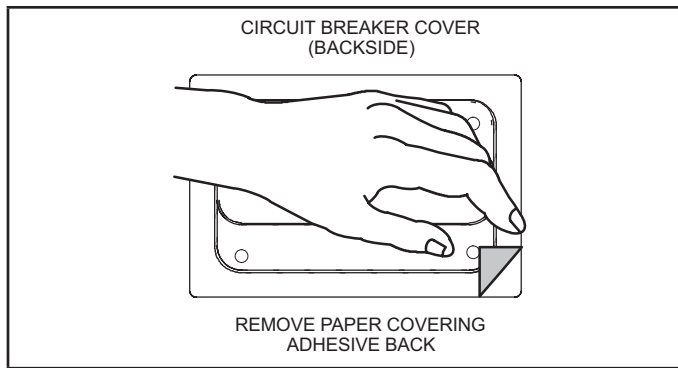

FIGURE 10. Remove Paper Cover

⚠ IMPORTANT

Confirm air tight seal between breaker cover and air handler access panel. Apply a thin silicone bead to the adhesive back seat to ensure air tight seal.

Failure to seal circuit breaker cover will allow warm moist air to be pulled into control panel which can create condensation to form on the circuit breaker and other electrical components within the control panel.

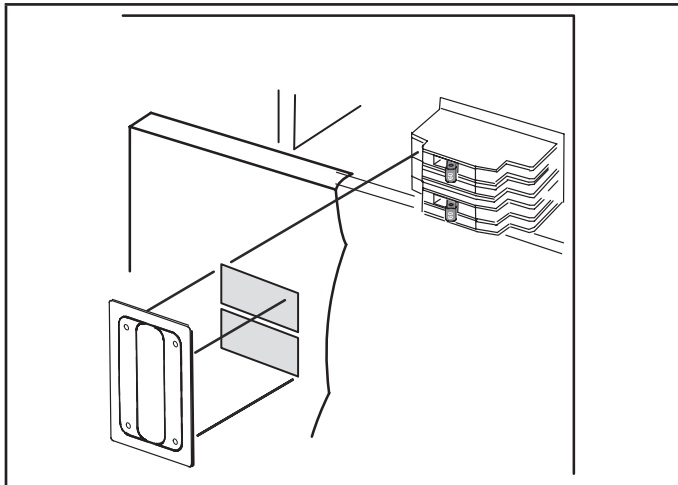

FIGURE 11. Typical Circuit Breaker Cover Installation

Air Handler Speed Connections

When using the electric heat sections with air handler units, you must adjust the air handler speed according to the size of electric heat and air handler unit. **Air handler speed tap for electric heat in upflow and horizontal position is medium. For downflow it is high speed.** See specific air handler installation instructions for air handler speed adjustment procedure and location.

- 1 - Set the thermostat above room temperature.
- 2 - Check the heat pump and the heat section for normal operation.
- 3 - Set the thermostat to desired setting.
- 4 - Affix the wiring diagram sticker to air handler scroll, aligned with circuit breaker unit wiring diagram sticker.

Configuration Modification

UPFLOW APPLICATION

- 1 - The air handler must be supported on the bottom only and set on solid floor or field-supplied support frame. Securely attach the air handler to the floor or support frame.
- 2 - If installing a unit in an upflow application, remove the horizontal drain pan. **IMPORTANT - The horizontal drain pan is not required in upflow air discharge installations; its removal provides the best efficiency and air flow.**
- 3 - Place the unit in the desired location and slope unit as previously mentioned. Connect return and supply air plenums as required using sheet metal screws.
- 4 - Install units that have no return air plenum on a stand that is at least 14" from the floor. This will allow proper air return.

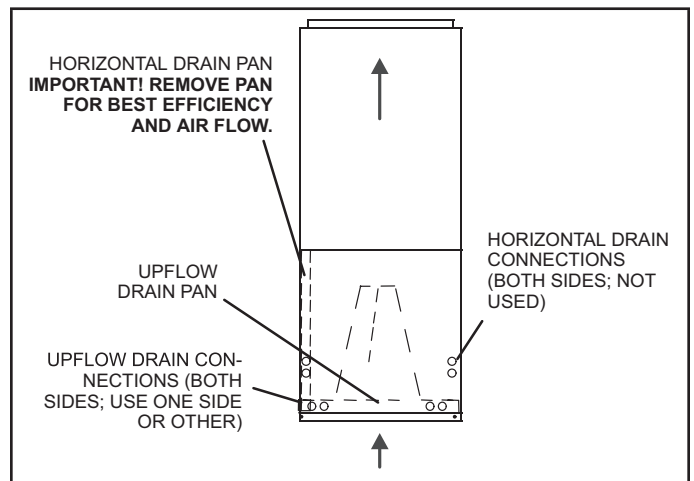

FIGURE 12. Upflow Configuration

HORIZONTAL APPLICATION

⚠ IMPORTANT

When removing the coil, there is possible danger of equipment damage and personal injury. Be careful when removing the coil assembly from a unit installed in right- or left-hand applications. The coil may tip into the drain pan once it is clear of the cabinet. Support the coil when removing it.

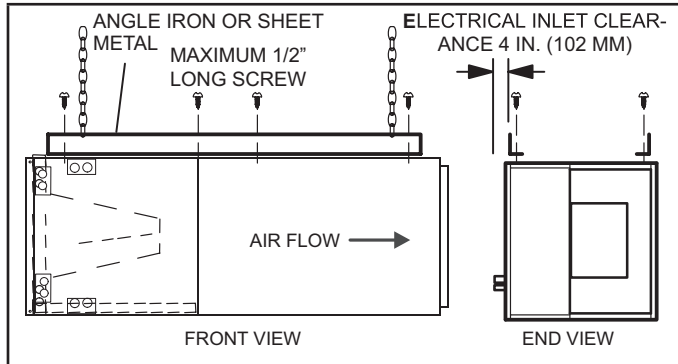

FIGURE 13. Suspend Horizontal Unit

NOTE – When the unit is installed in horizontal applications, a secondary drain pan is recommended. Refer to local codes.

NOTE – This unit may be installed in left- or right-hand air discharge horizontal applications. Adequate support must be provided to ensure cabinet integrity. Ensure that there is adequate room to remove service and access panels if installing in the horizontal position.

LEFT-HAND DISCHARGE

For horizontal left-hand air discharge, the following field modifications are required.

- 1 - Remove access panels and the corrugated padding between the blower and coil assembly. Discard the corrugated padding.
- 2 - Pull the coil assembly from unit. Pull off the horizontal drain pan.
- 3 - Remove the drain plugs from back drain holes on horizontal drain pan and reinstall them on front holes.

⚠ IMPORTANT

After removal of drain pan plug(s), check drain hole(s) to verify that drain opening is fully open and free of any debris. Also check to make sure that no debris has fallen into the drain pan during installation that may plug up the drain opening.

- 4 - Rotate drain pan 180° front-to-back and install it on the opposite side of the coil.
- 5 - Remove screws from top cap.
- 6 - Remove plastic plug from left hole on coil front end seal and reinstall plug in back hole.

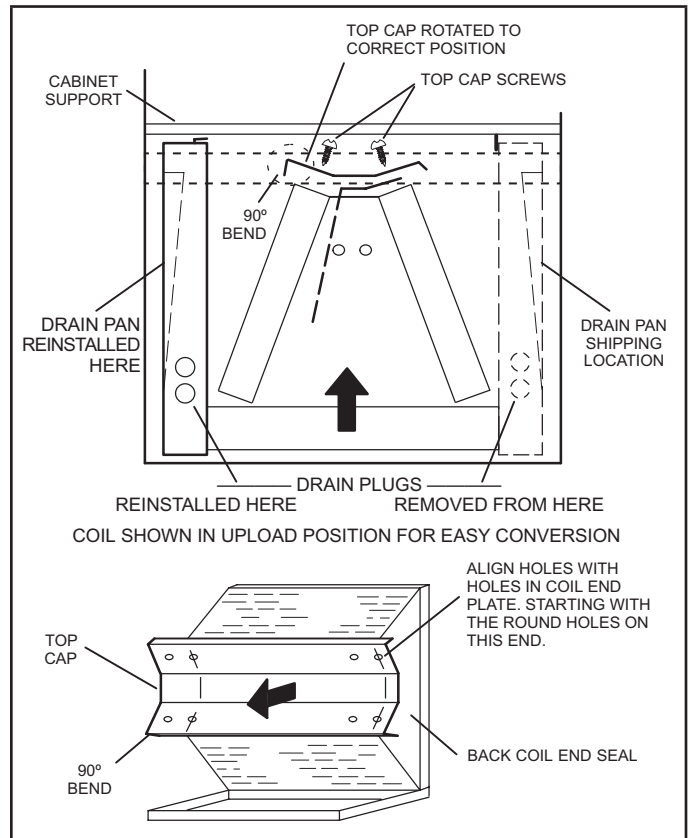

FIGURE 14. Field Modification for Left-Hand Discharge

- 7 - Rotate top cap 180° front-to-back and align with unused screw holes. Holes must align with front and back coil end plates. The top cap has a 45° bend on one side and a 90° bend on the other. **The 90° bend must be on the same side as the horizontal drain pan as illustrated in figure 14.**

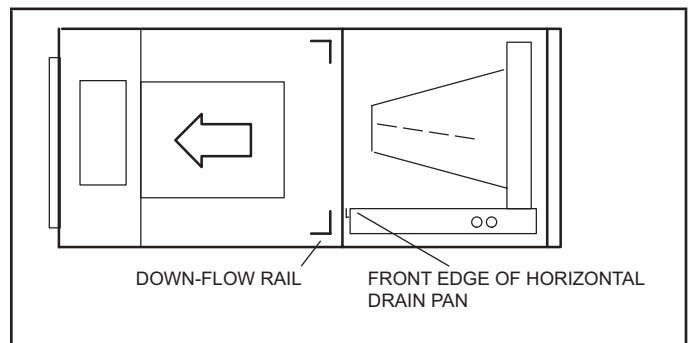

FIGURE 15. Left-Hand Discharge Configuration

NOTE – Be very careful when reinstalling the screws into the coil end plate engaging holes. Misaligned screws may damage the coil.

- 8 - From the upflow position, flip cabinet 90° to the left and set into place. Replace blower assembly. Secure coil in place by bending down the tab on the cabinet support rail as illustrated.
- 9 - Install the horizontal shield (-060 model) on the front edge of the horizontal drain pan as illustrated in figure 15.

NOTE – For horizontal applications in high humidity areas, remove the downflow rail closest to the drain pan. To remove rail, remove screw from rail at back of unit and at cabinet support rail. Remove downflow rail then replace screws. Also, seal around the exiting drain pipe, liquid and suction lines to prevent infiltration of humid air.

- 10 - Knock out drain seal plate from access door. Secure plate to cabinet front flange with screw provided.
- 11 - Flip access door and replace it on the unit.
- 12 - Set unit so that it is sloped 1/4" toward the drain pan end of the unit. Connect return and supply air plenums as required using sheet metal screws.
- 13 - If suspending the unit, it must be supported along the entire length of the cabinet. If using chain or strap, use a piece of angle iron or sheet metal attached to the unit (either above or below) so that the full length of the cabinet is supported. Use securing screws no longer than 1/2" to avoid damage to coil or filter, as illustrated in figure 13. Connect return and supply air plenums as required using sheet metal screws.

RIGHT-HAND DISCHARGE

- 1 - Determine which plugs are required for drain line connections.
- 2 - With access door removed, remove drain line plugs to install drain lines.
- 3 - Set unit so that it is sloped toward the upflow drain pan end of the unit and level from front to back of unit (see figure 7).
- 4 - The horizontal configuration is shown in figure 2.

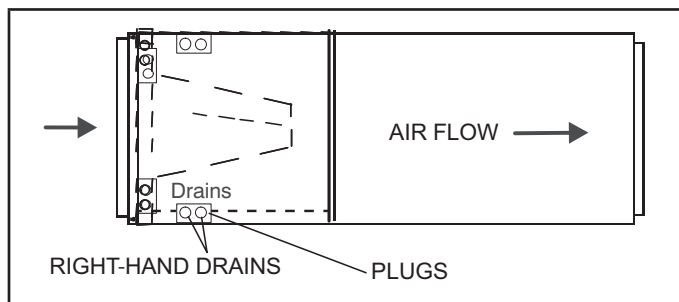

FIGURE 16. Right-Hand Discharge Configuration

- 5 - If the unit is suspended, the entire length of the cabinet must be supported. If you use a chain or strap, use a piece of angle iron or sheet metal attached to the unit (either above or below) to support the length of the cabinet. Use securing screws no longer than 1/2 inch to avoid damaging the coil or filter. See figure 13. Use sheet metal screws to connect the return and supply air plenums as required.

DOWNFLOW APPLICATION

NOTE – If downflow application is required, separately order kit number Y9658 (-018 through -030) or Y9659 (-036 through -060) and install per kit's instructions. Also use metal or class I supply and return air plenums.

Use the installation instruction provided with the downflow kit.

! IMPORTANT

If electric heat section with circuit breakers (ECBA25) is installed in a CBA25UHV unit in a downflow application, the circuit breakers must be rotated 180° to the UP position. See ECBA25 installation instructions for more details.

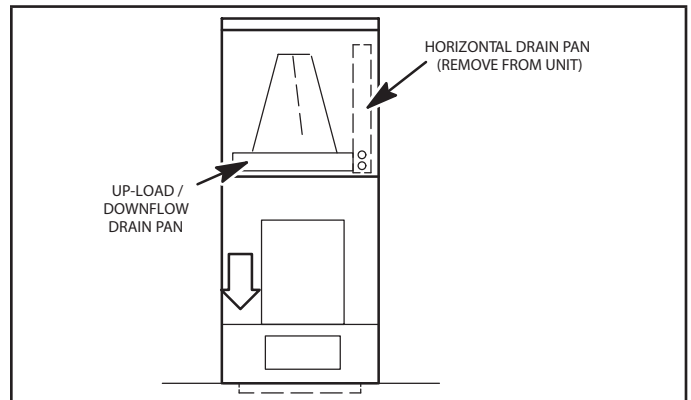

FIGURE 17. Downflow Discharge Position

Combustible Flooring Base

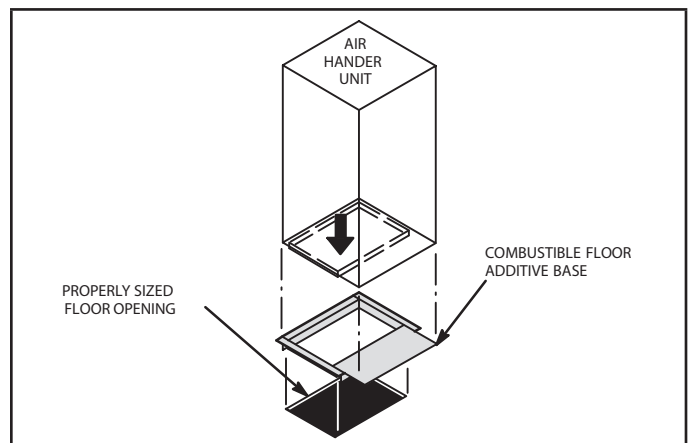

FIGURE 18. Downflow Combustible Flooring Base

- 1 - For downflow installation on combustible flooring, an additive base must be used as illustrated in figure 18. See CBA25UHV Engineering Handbook for downflow combustible flooring base kits available for this air handler.
- 2 - Cut an opening appropriately sized for combustible base. Base dimensions are illustrated in figure 10. After opening has been cut, set the additive base into opening. Connect outlet air plenum to the additive base. Set the unit on the additive base so flanges of the unit drop into the base opening and seal against the insulation strips. The unit is now locked in place. Install return air plenum and secure with sheet metal screws.

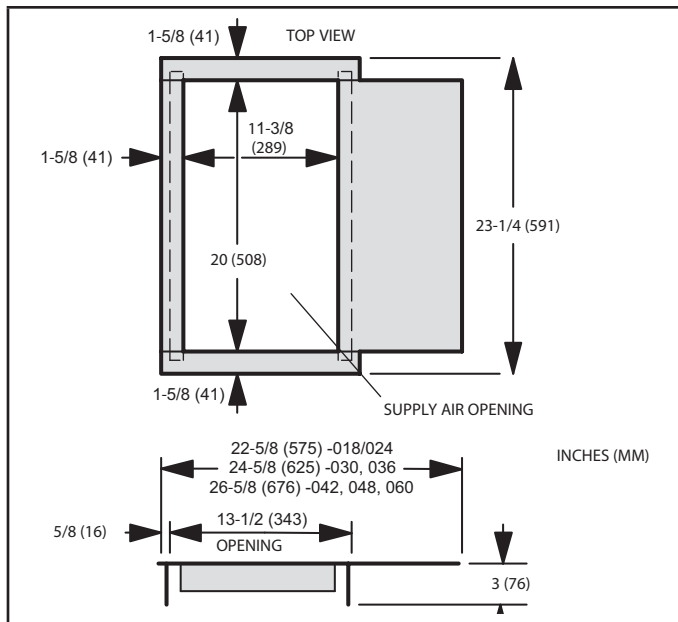

FIGURE 19. Downflow Combustible Base Dimensions

Brazing Connections

WARNING

Polyol ester (POE) oils used with HFC-410A refrigerant absorb moisture very quickly. It is very important that the refrigerant system be kept closed as much as possible. **DO NOT** remove line set caps or service valve stub caps until you are ready to make connections.

WARNING

Danger of fire. Bleeding the refrigerant charge from only the high side may result in pressurization of the low side shell and suction tubing. Application of a brazing torch to a pressurized system may result in ignition of the refrigerant and oil mixture. Check the high and low pressures before applying heat.

IMPORTANT

To prevent the build-up of high levels of nitrogen when purging, it must be done in a well-ventilated area. Purge low-pressure nitrogen (1 to 2 psig) through the refrigerant piping during brazing. This will help to prevent oxidation and the introduction of moisture into the system.

WARNING



Danger of explosion!
Can cause equipment damage, injury, or death.
When using a high pressure gas such as nitrogen to pressurize a refrigeration or air conditioning system, use a regulator that can control the pressure down to 1 or 2 psig (6.9 to 13.8 kPa).

CAUTION

Brazing alloys and flux contain materials which are hazardous to your health.
Avoid breathing vapors or fumes from brazing operations. Perform operations only in well ventilated areas.
Wear gloves and protective goggles or face shield to protect against burns.
Wash hands with soap and water after handling brazing alloys and flux.

WARNING



When using a high pressure gas such as nitrogen to pressurize a refrigeration or air conditioning system, use a regulator that can control the pressure down to 1 or 2 psig (6.9 to 13.8 kPa).

TABLE 5. CBA25UHV Refrigerant Connections and Line Set Requirements

Model	Liquid Line	Vapor Line	L15 Line Sets
-018/024	3/8" (10mm)	3/4" (19mm)	L15 line set sizes are dependant on unit match-up. See Product Specifications (EHB) for outdoor unit to determine correct line set sizes
-030-036	3/8" (10mm)	3/4" (19mm)	
-042-048	3/8" (10mm)	7/8" (22mm)	
-060	3/8" (10mm)	7/8" (22mm)	Field fabricated

NOTE - Some applications may require a field-provided 7/8" to 1-1/8" adapter.

NOTE - When installing refrigerant lines longer than 50 feet, see the *Lennox Refrigerant Piping Design and Fabrication Guidelines, CORP. 9351-L9*, or contact *Lennox Technical Support Product Applications* for assistance.

PLEASE READ IMPORTANT ISSUES CONCERNING BRAZING OPERATIONS BEFORE PROCEEDING.

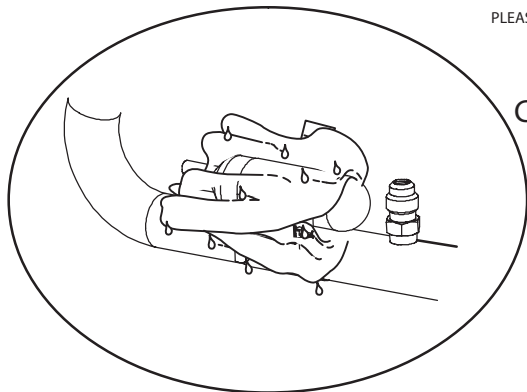

C USE A WET RAG TO PROTECT CTXV SENSING BULB WHEN BRAZING SUCTION LINE CONNECTIONS.

NOTE — REFER TO OUTDOOR UNIT INSTALLATION INSTRUCTIONS FOR REFRIGERANT PIPING SIZE REQUIREMENTS

NOTE - Use silver alloy brazing rods with five or six percent minimum silver alloy for copper-to-copper brazing, 45 percent alloy for copper-to-brass and copper-to-steel brazing.

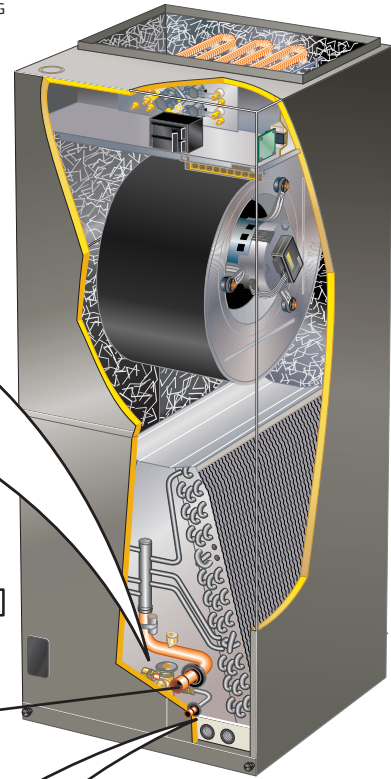

A REMOVE ACCESS PANEL

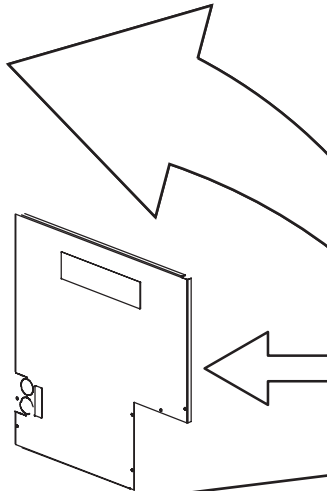

B REMOVE RUBBER PLUG FROM BOTH LIQUID AND SUCTION LINES

NOTE — CBA25UHV SERIES UNITS USE NITROGEN OR DRY AIR AS A HOLDING CHARGE. IF THERE IS NO PRESSURE WHEN THE RUBBER PLUGS ARE REMOVED, CHECK THE COIL FOR LEAKS BEFORE INSTALLING.

D EITHER REMOVE OR PUSH PIPE WRAPPING BACK THROUGH HOLE IN PIPING PLATE BEFORE LINE SET CONNECTION AND BRAZING.

F CONNECT GAUGES AND START NITROGEN FLOW

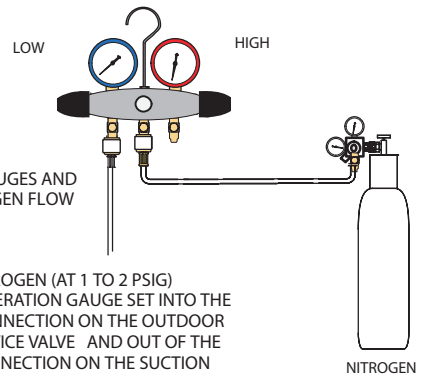

FLOW REGULATED NITROGEN (AT 1 TO 2 PSIG) THROUGH THE REFRIGERATION GAUGE SET INTO THE VALVE STEM PORT CONNECTION ON THE OUTDOOR UNIT LIQUID LINE SERVICE VALVE AND OUT OF THE VALVE STEM PORT CONNECTION ON THE SUCTION SERVICE VALVE.

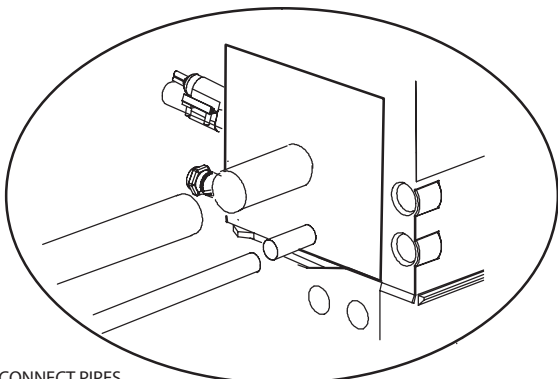

E CONNECT PIPES

NOTE — REFRIGERANT LINE SETS SHOULD BE ROUTED TO ALLOW FILTER ACCESSIBILITY.

G PLACE A WET RAG AGAINST PIPING PLATE AND AROUND THE SUCTION LINE CONNECTION. A

H BRAZE CONNECTION. ALLOW PIPE TO COOL BEFORE REMOVING WET RAG FROM CTXV SENSING BULB AND PIPING PANEL AREA.

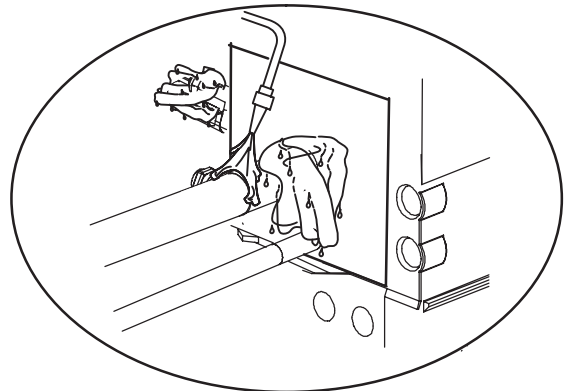

I REPEAT PREVIOUS PROCEDURE FOR LIQUID LINE.

REFER TO INSTRUCTIONS PROVIDED WITH OUTDOOR UNIT FOR LEAK TESTING, EVACUATING AND CHARGING PROCEDURES

FIGURE 20. Brazing Connections

Installing the Condensate Drain

! IMPORTANT

On units of this type, where the blower “draws” rather than “blows” air through the coil, traps must be installed in the condensate drain lines (primary and auxiliary, if used). Traps prevent the blower from drawing air through the drain lines into the air supply.

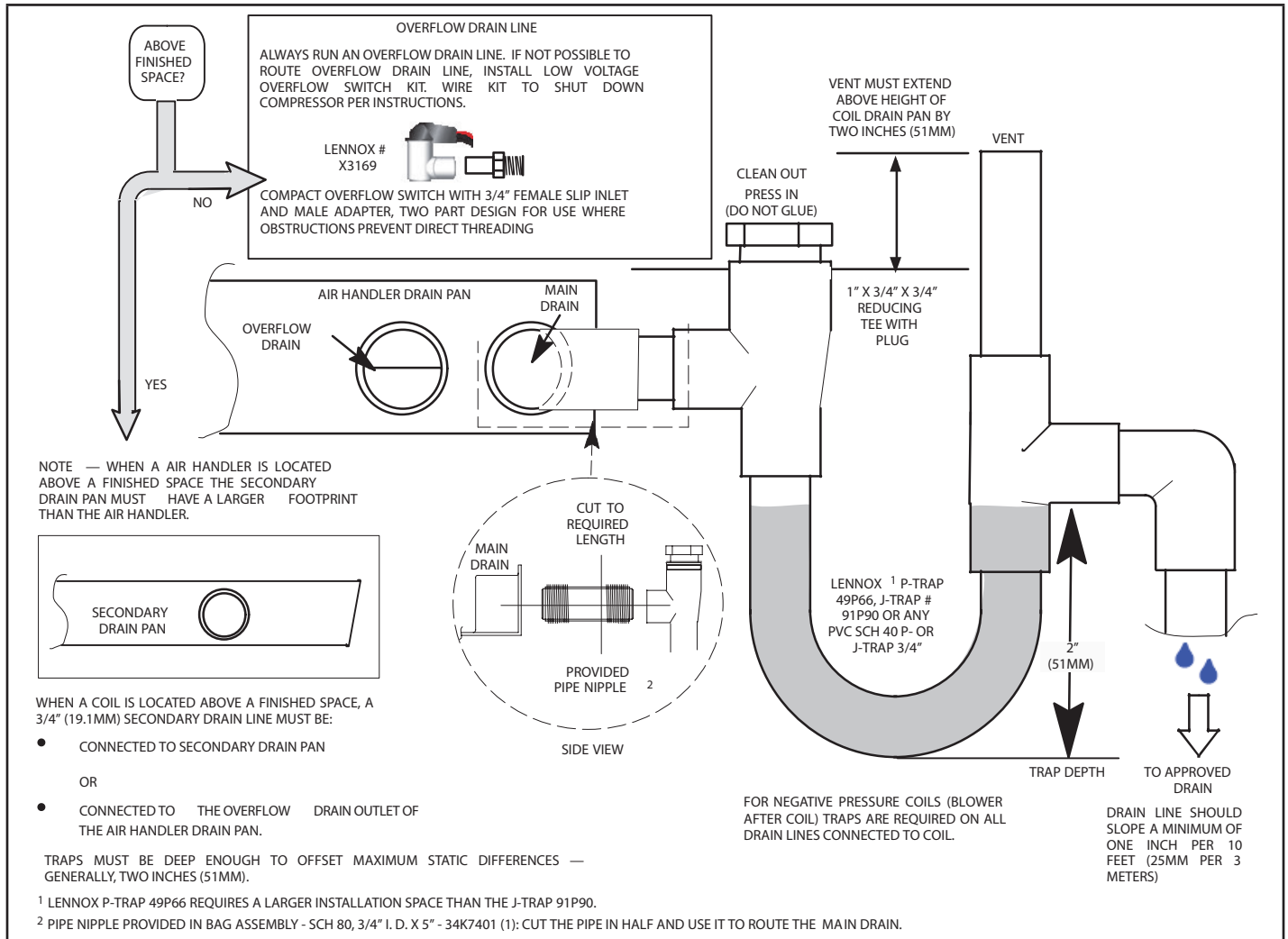

FIGURE 21. Typical Main and Overflow Drain Installations

! IMPORTANT

After removal of drain pan plug(s), check drain hole(s) to verify that drain opening is fully open and free of any debris. Also check to make sure that no debris has fallen into the drain pan during installation that may plug up the drain opening.

SLOPING THE UNIT

Make sure the unit is sloped (similar to the slope shown in figure 22) so that the drain pan will empty completely without water standing in the pan.

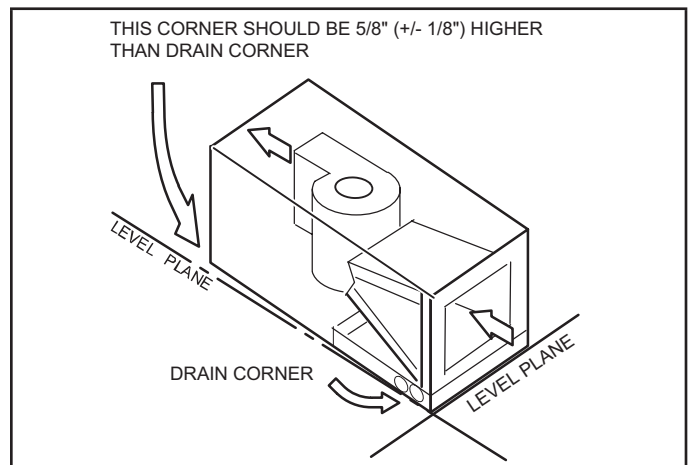

FIGURE 22. Sloping the Unit for Proper Drainage

- 1 - Remove the appropriate drain knockouts. If necessary, remove the indoor coil assembly from the cabinet.
- 2 - Connect primary drain line connection to the primary drain pan connection. The primary drain connection is flush with the bottom of the inside of the pan. Secondary connection is raised above the bottom of the inside of the pan.

NOTE – When making drain fitting connections to the drain pan, hand tighten the fitting and use a thread sealant. Over-tightening the fittings can split connections on the drain pan.

- 3 - If the auxiliary drain line is to be used, remove the plug and route the drain line so that water draining from the outlet will be easily noticed by the homeowner. The auxiliary drain line does not require venting or a trap. Refer to local codes.
- 4 - After removal of drain pan plugs, check the drain port to see if holes have been drilled. If not drilled, use a 19/32" bit to drill out the primary drain hole; use a 3/8" drill bit for the secondary drain hole. Remove all drill shavings.
- 5 - Make sure drain ports and drain pan are free of all debris.
- 6 - Plug and check any unused drain pan openings for tightness. Torque plugs to 30 in. lb. to prevent water leaks or seepage from the drain pan.
- 7 - Install a 2" trap in the primary drain lines as close to the unit as practical (see figure 21). Make sure the top of the trap is below the connection to the drain pan to allow complete drainage of the pan.

NOTE – Horizontal runs must have an anti-siphon air vent (standpipe) installed ahead of the horizontal run. An extremely long horizontal run may require an oversized drain line to eliminate air trapping.

NOTE – Do not operate air handler without a drain trap. The condensate drain is on the negative pressure side of the blower; therefore, air being pulled through the condensate line will prevent positive drainage without a proper trap.

- 8 - Route the drain line to the outside or to an appropriate drain. Drain lines must be installed so they do not block service access to the front of the air handler. A 24" clearance is required for filter, coil, or blower removal and service access.

NOTE – Check local codes before connecting the drain line to an existing drainage system.

Insulate the drain lines where sweating could cause water damage.

TEST CONDENSATE DRAIN

Test the drain pan and drain line after installation:

- 1 - Pour several quarts of water into drain pan, enough to fill drain trap and line.

- 2 - Check to make sure the drain pan is draining completely, no leaks are found in drain line fittings, and water is draining from the end of the primary drain line.

- 3 - Correct any leaks found.

BEST PRACTICES

The following best practices are recommended for the condensate removal process:

- Main and overflow drain lines should **NOT** be smaller than both drain connections at drain pan.
- Overflow drain line should run to an area where homeowner will notice drainage.
- It is recommended that the overflow drain line be vented and a trap installed. Refer to local codes.
- Condensate drain lines must be configured or provided with a cleanout to permit the clearing of blockages and for maintenance without requiring the drain line to be cut.

IMPORTANT

A field-fabricated secondary drain pan, with a drain pipe to the outside of the building, is required in all installations over a finished living space or in any area that may be damaged by overflow from the main drain pan. In some localities, local codes may require a secondary drain pan for any horizontal installation.

DUCT SYSTEM

The air handler is provided with flanges for the connection of the plenum and ducts. The air handler is equipped with flanges that can form a filter rack for the installation of the air filter, or the filter may be installed as part of the return air duct system.

Supply and return duct system must be adequately sized to meet the system's air requirements and static pressure capabilities. The duct system should be insulated with a minimum of 1" thick insulation with a vapor barrier in conditioned areas or 2" minimum in unconditioned areas.

Supply plenum should be the same size as the flanged opening provided around the blower outlet and should extend at least 3 ft. from the air handler before turning or branching off plenum into duct runs. The plenum forms an extension of the blower housing and minimizes air expansion losses from the blower.

INSTALLING DUCT SYSTEM

Connect supply air duct to the flange on top of the air handler. If an isolation connector is used, it must be nonflammable.

A return air duct system is recommended. If the unit is installed in a confined space or closet, a return connection must be run, full size, to a location outside the closet.

CONNECTING REFRIGERANT LINES

Refrigerant lines must be connected by a qualified technician in accordance with established procedures.

⚠ IMPORTANT

Refrigerant lines must be clean, dehydrated, refrigerant-grade copper lines. Air handler coils should be installed only with specified line sizes for approved system combinations.

Handle the refrigerant lines gently during the installation process. Sharp bends or possible kinking in the lines will cause a restriction.

Do not remove the caps from the lines or system connection points until connections are ready to be completed.

- 1 - Route the suction and liquid lines from the fittings on the indoor coil to the fittings on the outdoor unit. Run the lines in as direct a path as possible avoiding unnecessary turns and bends.
- 2 - Make sure that the suction line is insulated over the entire exposed length and that neither suction nor liquid lines are in direct contact with floors, walls, duct system, floor joists, or other piping.
- 3 - Connect the suction and liquid lines to the evaporator coil.
- 4 - To avoid damaging the rubber grommets in the cabinet while brazing, slide the rubber grommets over the refrigerant lines until they are away from the heat source.
- 5 - Braze using an alloy of silver or copper and phosphorus with a melting point above 1,100°F (593°C).

NOTE – Do not use soft solder.

6. Reinstall the rubber grommets after brazing is finished.
7. Make sure outdoor unit has been put in place according to the Installation Instructions and is connected to the refrigerant lines.

SEALING THE UNIT

Seal the unit so that warm air is not allowed into the cabinet. Warm air introduces moisture, which results in water blow-off problems. This is especially important when the unit is installed in an unconditioned area.

If installed in an unconditioned space, sealant should be applied around the electrical wires, refrigerant tubing, and condensate lines where they enter the cabinet.

⚠ WARNING

There must be an airtight seal between the bottom of the air handler and the return air plenum. Use fiberglass sealing strips, caulking, or equivalent sealing method between the plenum and the air handler cabinet to ensure a tight seal. Return air must not be drawn from a room where this air handler or any gas-fueled appliance (i.e., water heater), or carbon monoxide-producing device (i.e., wood fireplace) is installed.

Make sure the liquid line and suction line entry points are sealed with either the provided flexible elastomeric thermal insulation, or field provided material (e.g. Armaflex, Permagem or equivalent). Any of the previously mentioned materials may be used to seal around the main and auxiliary drains, and around open areas of electrical inlets.

Electrical Connections

⚠ WARNING



Electric Shock Hazard. Can cause injury or death. Unit must be properly grounded in accordance with national and local codes.

Line voltage is present at all components when unit is not in operation on units with single-pole contactors. Disconnect all remote electric power supplies before opening access panel. Unit may have multiple power supplies.

⚠ WARNING

Electric Shock Hazard.

Can cause injury or death.

Foil-faced insulation has conductive characteristics similar to metal. Be sure there are no electrical connections within a 1/2" of the insulation. If the foil-faced insulation comes in contact with electrical voltage, the foil could provide a path for current to pass through to the outer metal cabinet. While the current produced may not be enough to trip existing electrical safety devices (e.g. fuses or circuit breakers), the current can be enough to cause an electric shock hazard that could cause personal injury or death.

- All field wiring must be done in accordance with National Electrical Code, applicable requirements of UL and local codes, where applicable.
- Electrical wiring, disconnect means and over-current protection are to be supplied by the installer. Refer to the air handler rating plate for maximum over-current protection, minimum circuit ampacity, as well as operating voltage.
- The power supply must be sized and protected according to the specifications supplied on the product.
- This air handler is factory-configured for 240 volt, single phase, 60 cycles. For 208-volt applications, see "208 Volt Conversion" later in this section.
- For optional field-installed electric heat applications, refer to the instructions provided with the accessory for proper installation.

⚠ IMPORTANT

USE COPPER CONDUCTORS ONLY

- 1 - Disconnect all power supplies.
- 2 - Remove the air handler access panel.
- 3 - Route the field supply wires to the air handler electrical connection box.
- 4 - Use UL-listed wire nuts to connect the field supply conductors to the unit black and yellow leads, and the ground wire to ground terminal marked GND.
- 5 - 5. Replace the air handler access panel.

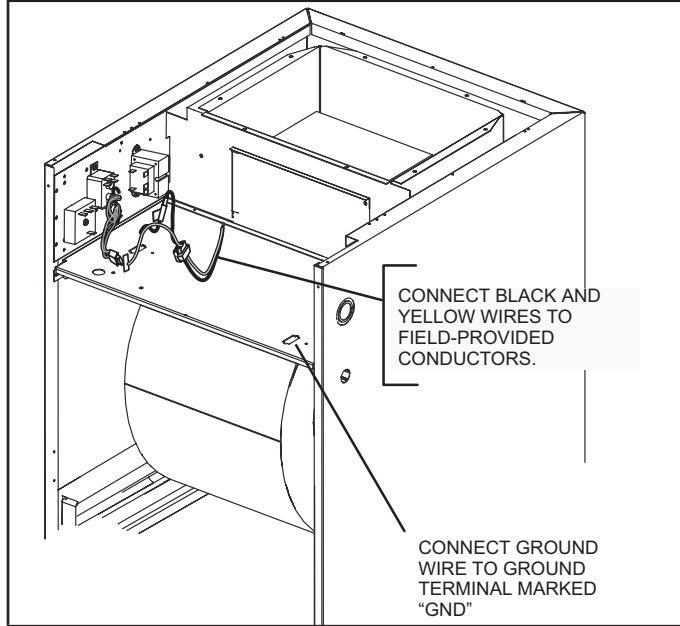

FIGURE 23. Making Electrical Connections

208 VOLT CONVERSION

- 1 - Disconnect all power supplies.
- 2 - Remove the air handler access panel.
- 3 - Using the wiring diagram located on the unit access panel as a reference, move the 2 connected black transformer leads from the 240 volt terminal on the transformer to the 208 volt terminal on the transformer.

⚠ WARNING	
	<p>Electrically ground air handler. Connect ground wire to ground terminal marked "GND".</p> <p>Failure to do so can result in death or electrical shock.</p>

Inspecting and Replacing Filters

⚠ IMPORTANT	
<p>Filter access door must be in place during unit operation. Excessive warm air entering the unit from unconditioned space may result in water blow-off problems.</p>	

Filters may be duct-mounted or installed in the cabinet. A filter is installed at the factory. Note that filter access door fits over access panel. Air will leak if the access panel is placed over the filter door.

Filters should be inspected monthly and must be cleaned or replaced when dirty to assure proper furnace operation.

To replace filter:

- 1 - Loosen the thumbscrews holding the filter panel in place.
- 2 - Slide the filter out of the guides on either side of cabinet.
- 3 - Insert new filter.
- 4 - Replace panel.

See table 3 for replacement filter sizes.

TABLE 6. Filter Dimensions

CBA25UHV	Filter Size – In. (mm)
-018/024, -030, -036	15 x 20 x 1 (381 x 508 x 25)
-042, -048, -060	18 x 20 x 1 (457 x 508 x 25)

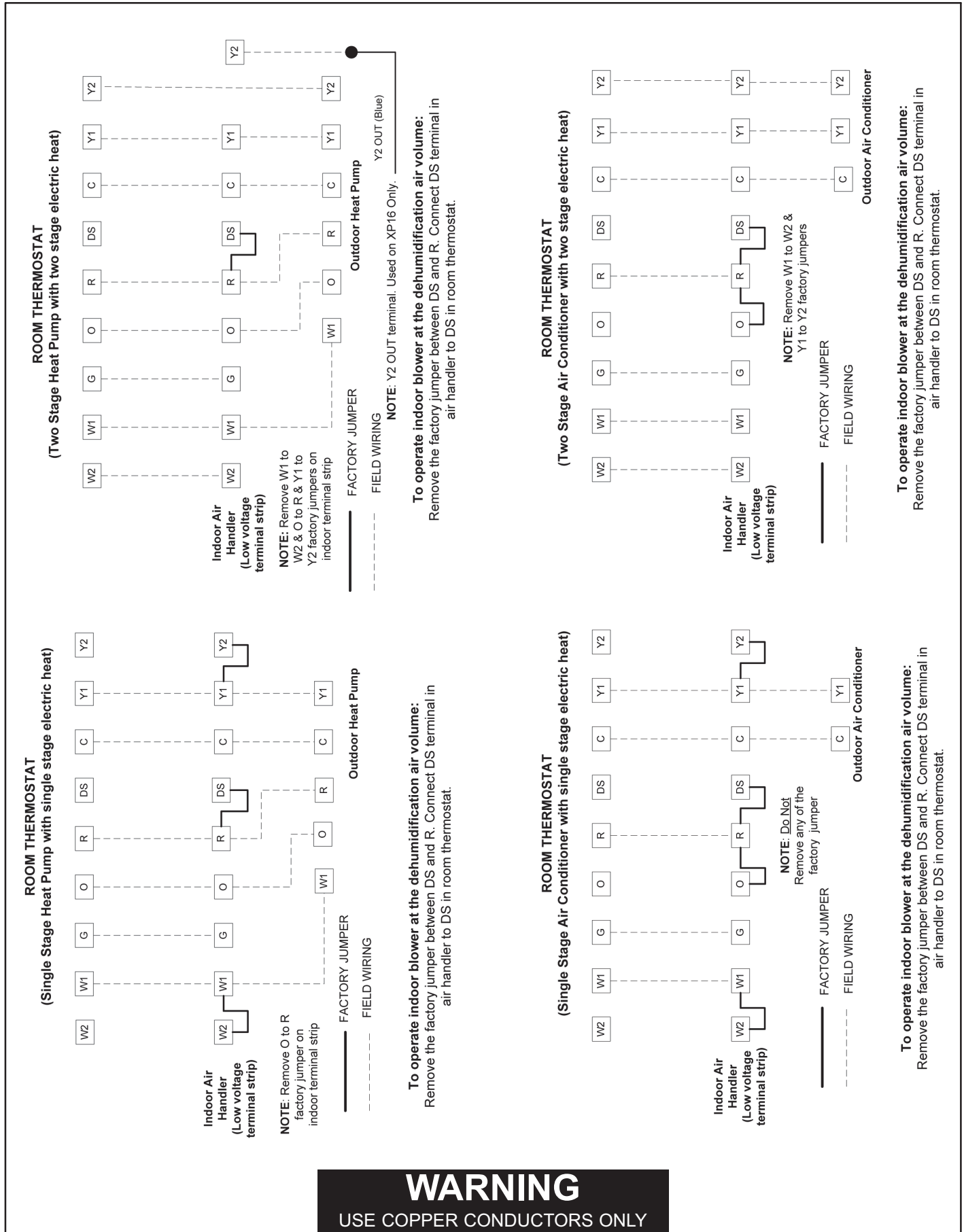

FIGURE 25. Low Voltage Connections (Variable-Speed Motor)

Professional Maintenance

NOTICE !

Failure to follow instructions will cause damage to the unit.

This unit is equipped with an aluminum coil. Aluminum coils may be damaged by exposure to solutions with a pH below 5 or above 9. The aluminum coil should be cleaned using potable water at a moderate pressure (less than 50psi). If the coil cannot be cleaned using water alone, Lennox recommends use of a coil cleaner with a pH in the range of 5 to 9. The coil must be rinsed thoroughly after cleaning.

In coastal areas, the coil should be cleaned with potable water several times per year to avoid corrosive buildup (salt).

Check-out Procedures

IMPORTANT

During installation, service or maintenance, make sure that copper tubing does not rub against metal edges or other copper tubing. Care should also be taken to ensure that tubing does not become kinked. Use wire ties to secure tubing to prevent movement.

Do not secure electrical wires to tubing that carries hot refrigerant gas. Heat from the tubing may melt the wiring insulation, causing a short circuit.

NOTE – Refer to outdoor unit installation instructions for system start-up instructions and refrigerant charging instructions.

PRE-START-UP CHECKS

- Is the air handler properly and securely installed?
- If horizontally configured, is the unit sloped up to 1/4 inch toward drain lines?
- Will the unit be accessible for servicing?
- Has an auxiliary pan been provided under the unit with separate drain for units installed above a finished ceiling or in any installation where condensate overflow could cause damage?
- Have ALL unused drain pan ports been properly plugged?
- Has the condensate line been properly sized, run, trapped, pitched, and tested?
- Is the duct system correctly sized, run, sealed, and insulated?
- Have all cabinet openings and wiring been sealed?
- Is the indoor coil factory-installed TXV properly sized for the outdoor unit being used?
- Have all unused parts and packaging been disposed of?

- Is the filter clean, in place, and of adequate size?
- Is the wiring neat, correct, and in accordance with the wiring diagram?
- Is the unit properly grounded and protected (fused)?
- Is the thermostat correctly wired and in a good location?
- Are all access panels in place and secure?

CHECK BLOWER OPERATION

- Set thermostat to FAN ON.
- The indoor blower should come on.

CHECK COOLING OPERATION

- Set thermostat to force a call for cooling (approximately 5°F lower than the indoor ambient temperature).
- The outdoor unit should come on immediately and the indoor blower should start between 30 - 60 seconds later.
- Check the air flow from a register to confirm that the system is moving cooled air.
- Set the thermostat 5°F higher than the indoor temperature. The indoor blower and outdoor unit should cycle off.

CHECK ELECTRIC HEAT (IF USED)

- Set thermostat to call for auxiliary heat (approximately 5°F above ambient temperature). The indoor blower and auxiliary heat should come on together. Allow a minimum of 3 minutes for all sequencers to cycle on.
- Set the thermostat so that it does not call for heat. Allow up to 5 minutes for all sequencers to cycle off.

Use of Air Handler During Construction

Lennox does not recommend the use of its air handler unit during any phase of construction. Very low return air temperatures, harmful vapors and operation of the unit with clogged or misplaced filters will damage the unit.

Air handler units may be used for heating (heat pumps) or cooling of buildings under construction, if the following conditions are met:

- A room thermostat must control the air handler. The use of fixed jumpers is not allowed.
- Air filter must be installed in the system and must be maintained during construction.
- Air filter must be replaced upon construction completion.
- The air handler evaporator coil, supply fan assembly and duct system must be thoroughly cleaned following final construction clean-up.
- All air handler operating conditions must be verified according to these installation instructions.

Sequence of Operation

COOLING (COOLING ONLY OR HEAT PUMP)

When the thermostat calls for cooling, 24 volts is put on the blower time-delay relay coil and then the indoor blower relay energizes. The normally open contacts close, causing the indoor blower motor to operate. The circuit between **R** and **Y** is completed, closing the circuit to the contactor in the outdoor unit, starting the compressor and outdoor fan motor.

On heat pumps, circuit **R** and **O** energizes the reversing valve, switching the valve to the cooling position. (The reversing valve remains energized as long as the thermostat selector switch is in the COOL position.)

At the completion of the cooling demand, the indoor blower and outdoor unit should cycle off. Air handler should cycle off 45 seconds after the outdoor unit shuts off.

HEATING (ELECTRIC HEAT ONLY)

When the thermostat calls for heat, the circuit between **R** and **W** is completed, and the heat sequencer is energized. A time delay follows before the heating elements and the indoor blower motor come on. Units with a second heat sequencer can be connected with the first sequencer to **W** on the thermostat subbase, or they may also be connected to a second stage on the subbase.

HEATING (HEAT PUMP)

When the thermostat calls for heating, 24 volts is put on the blower time-delay relay coil. Then normally open contacts close, causing the indoor blower motor to operate. The circuit between **R** and **Y** is completed, closing the circuit to the contactor in the outdoor unit, starting the compressor and outdoor fan motor.

If the room temperature should continue to fall, the circuit between **R** and **W1** is completed by the second-stage heat room thermostat. Circuit **R-W1** energizes a heat sequencer. The completed circuit will energize supplemental electric heat (if applicable). Units with a second heat sequencer can be connected with the first sequencer to **W1** on the thermostat. They may also be connected to a second heating stage **W2** on the thermostat subbase.

EMERGENCY HEAT (HEATING HEAT PUMP)

If the selector switch on the thermostat is set to the emergency heat position, the heat pump will be locked out of the heating circuit, and all heating will be electric heat (if applicable). A jumper should be placed between **W2** and **E** on the thermostat subbase so that the electric heat control will transfer to the first-stage heat on the thermostat. This will allow the indoor blower to cycle on and off with the electric heat when the fan switch is in the AUTO position.

Installing Contractor's Name _____

Installing Date _____

Installing Contractor's Phone _____

Air Handler Model # _____

Job Address _____

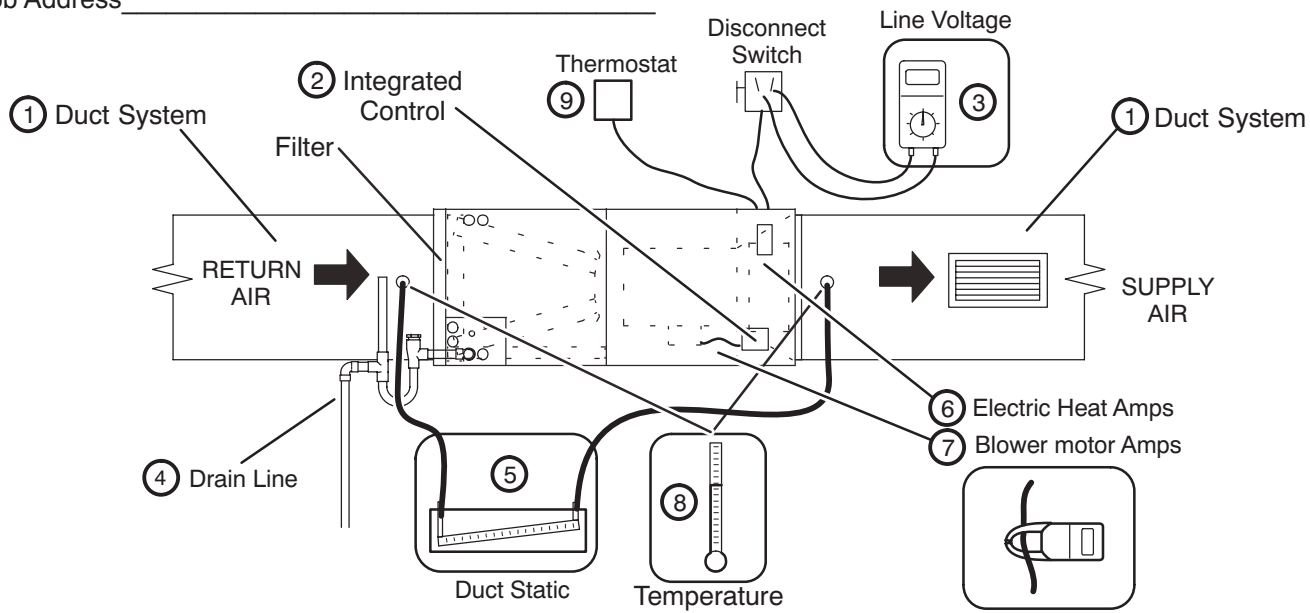

① DUCT SYSTEM

SUPPLY AIR DUCT

- Sealed
- Insulated (if necessary)
- Registers Open and Unobstructed

RETURN AIR DUCT

- Sealed
- Filter Installed and Clean
- Registers Open and Unobstructed

② INTEGRATED CONTROL

- Jumpers Configured Correctly (if applicable)
- Appropriate Links in Place (if applicable)

③ VOLTAGE CHECK

- Supply Voltage _____
- Low Voltage _____
- Electrical Connections Tight

④ DRAIN LINE

- Leak Free

Explained Operation of System to Homeowner

⑤ TOTAL EXTERNAL STATIC (dry coil)

dry coil wet coil

Supply External Static _____

Return External Static _____

Total External Static = _____

⑥ ELECTRIC HEAT AMPS _____

⑦ INDOOR BLOWER AMPS _____

INDOOR BLOWER CFM _____

⑧ TEMPERATURE DROP (Cooling Mode)

Return Duct Temperature _____

Supply Duct Temperature - _____

Temperature Drop = _____

⑧ TEMPERATURE RISE (Heating Mode)

Return Duct Temperature _____

Supply Duct Temperature - _____

Temperature Rise = _____

⑨ THERMOSTAT

- Adjusted and Programmed
- Operation Explained to Owner

Technician's Name: _____ Date Start-Up & Performance Check Completed _____

FIGURE 27. Start-Up and Performance Checklist (Horizontal Configuration)