



ENGINEERING DATA

13CHA
MERIT® SERIES
Residential - R-22

Bulletin No. 210449
September 2007
Supersedes June 2007



SEER - 13.00
2 to 5 Tons
Cooling Capacity - 23,000 to 55,500 Btuh
Optional Electric Heat - 5 to 20 kW

MODEL NUMBER IDENTIFICATION

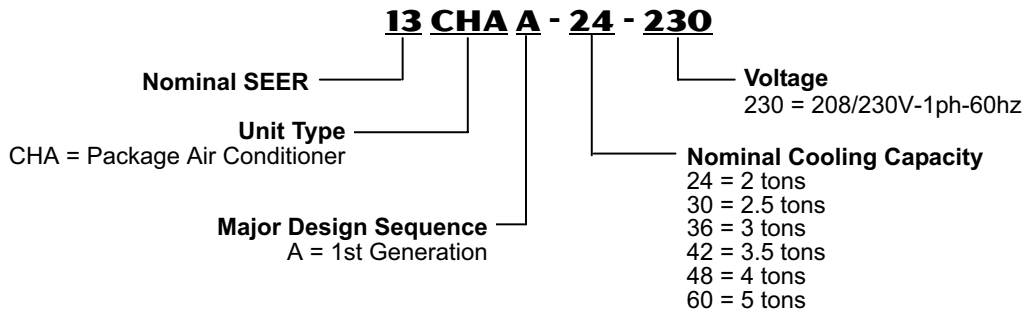

FEATURES



CONTENTS

Blower Data	Page 7
Dimensions	Page 8
Dimensions - Accessories	Page 9
Electric Heat/Electrical Data	Pages 5-6
Expanded Cooling Ratings	Page 10
Features	Pages 2-3
Field Wiring	Page 6
Installation Clearances	Page 7
Model Number Identification	Page 1
Optional Accessories	Page 4
Specifications	Page 4

EQUIPMENT WARRANTY

Compressor - limited warranty for **five years** in residential installations and five years in non-residential installations.

All other covered components - **five years** in residential installations and one year in non-residential installations.

Refer to Lennox Equipment Limited Warranty certificate included with unit for specific details.

APPROVALS

Units are design certified by UL.

Cooling system rated according to DOE test procedures.

Cooling system rated in accordance with ARI standard 210/240.

Units are listed by UL for the U.S. and Canada.

Packaged unit and components within bonded for grounding to meet safety standards required by UL.

Optional electric heaters are UL and ULC listed and are rated and tested according to DOE test procedures and FTC labeling regulations.

Each unit test operated at the factory before shipment ensuring dependable operation at start-up.

APPLICATIONS

Designed for outdoor installations at ground level or rooftop for residential applications.

CABINET

- 1 Conditioned areas insulated with foil faced insulation to minimize heat loss and reduce operating sound levels.
Powder paint for maximum durability.
Easy service access.
PVC coated steel wire coil guard furnished as standard.
Interchangeable panels for horizontal to down-flow airflow conversion furnished (shipped for horizontal).

Electrical Inlets and Service Valves

Field wiring inlets are located in one central area of the cabinet. See dimension drawing.

Gauge ports are located inside the cabinet.

OPTIONS

Lifting Brackets

Available to facilitate rigging of the unit.

Roof Curbs

Mates to unit.

Shipped knocked down.

Available in 8 in. and 14 in. heights.

REFRIGERATION SYSTEM

- 2 **Evaporator and Condenser Coils**
Copper tube with aluminum fin coils.

Evaporator Coil Drain Pan

Corrosion resistant plastic drain pan.

- 3 **Condenser Fan**

Weather protected heavy duty condenser fan motor with coated steel fan blades for long life.

Internally mounted.

Totally enclosed motor.

Fan guard constructed of corrosion-resistant PVC (polyvinyl chloride) coated steel.

FEATURES

4 SCROLL COMPRESSOR

Compressor features high efficiency with uniform suction flow, constant discharge flow and high volumetric efficiency and quiet operation.

Compressor consists of two involute spiral scrolls matched together to generate a series of crescent shaped gas pockets between them.

During compression, one scroll remains stationary while the other scroll orbits around it.

Gas is drawn into the outer pocket, the pocket is sealed as the scroll rotates.

As the spiral movement continues, gas pockets are pushed to the center of the scrolls. Volume between the pockets is simultaneously reduced.

When pocket reaches the center, gas is now at high pressure and is forced out of a port located in the center of the fixed scrolls.

During compression, several pockets are compressed simultaneously resulting in a smooth continuous compression cycle.

Continuous flank contact, maintained by centrifugal force, minimizes gas leakage and maximizes efficiency.

Scroll compressor is tolerant to the effects of slugging and contaminants. If this occurs, scrolls separate, allowing liquid or contaminants to be worked toward the center and discharged.

Low gas pulses during compression reduces operational sound levels.

Compressor motor is internally protected from excessive current and temperature.

Compressor is installed in the unit on resilient rubber mounts for vibration free operation.

OPTIONS

Compressor Crankcase Heater

Protects against refrigerant migration that can occur during low ambient operation.

Compressor Hard Start Kit

Single-phase units are equipped with a PSC compressor motor. This type of motor normally doesn't need a potential relay and start capacitor.

In conditions such as low voltage, this kit may be required to increase the compressor starting torque.

SUPPLY AIR BLOWER

5 Direct Drive Blower

Each blower assembly statically and dynamically balanced.

Blower assembly easily removed for servicing

Multi-speed, direct drive blower motor.

Change in blower speed is easily accomplished by simple wiring change on blower motor.

See Blower Performance tables.



CONTROLS

- 6 Solid-state blower control.
Single pole contactor.
Trade available components.

- 7 **24 Volt Transformer**

40VA transformer furnished and factory installed in control area.

OPTIONS

Low Ambient Kit

Air conditioners operate satisfactorily down to 45°F outdoor air temperature without any additional controls. Low Ambient Control Kit can be field installed, allowing unit operation down to 30°F.

Thermostat

See Thermostat bulletins in Controls section and Lennox Price Book for a complete list of thermostats.

AIR FILTER OPTIONS (REQUIRED)

Filters are not furnished - must be field provided.

OPTIONS

Internal Filter Kits

Available for 1, 2, 4, or 5 in. thick filters. Kit contains filter rails for mounting filters internal to unit. Filters must be field provided. MERV 10 and MERV 16 filters are available separately or other 1, 2, 4 or 5 inch thick filters can be used.

MERV Filters for Internal Filter Kits

Disposable, pleated MERV 10 and MERV 16 filter (Minimum Efficiency Reporting Value based on ASHRAE 52.2).

Dust mites, pollen, mold spores, pet dander and other contaminants are captured by the filter.

Double-wall beverage board frame for rigid construction. Recommended replacement of the media depends on a variety of factors, see Specifications table.

Media is certified to UL 900 standard and UL/ULC classification - Class 2.

ELECTRIC HEAT (5-20 KW)

Field install internal to unit cabinet.

Available in several voltages and kw sizes.

Helix wound nichrome heating elements exposed directly in air stream resulting in instant heat transfer, low element temperatures and long service life.

Cutoff limit control provides positive protection in case of excessive temperatures.

Factory assembled with controls installed and wired.

Single Point Power Kits

Control Box used with optional electric heat when single power supply is connected to multi-circuit electric heat.

SPECIFICATIONS
2-5 TON

General Data		Model No.	13CHAA-24	13CHAA-30	13CHAA-36	13CHAA-42	13CHAA-48	13CHAA-60	
Nominal Tonnage			2	2.5	3	3.5	4	5	
Cooling Performance	Total cooling capacity - Btuh		23,000	28,800	36,000	41,000	47,000	55,500	
	Total unit watts		2000	2500	3130	3570	4090	5020	
	¹ SEER (Btuh/Watt)		13.00	13.00	13.00	13.00	13.00	13.00	
	EER (Btuh/Watt)		11.50	11.50	11.50	11.50	11.50	11.05	
	² Sound Rating Number (dB)		81	81	81	79	79	79	
Refrigerant Type			R-22	R-22	R-22	R-22	R-22	R-22	
Refrigerant Charge			6 lbs. 8 oz.	6 lbs. 2 oz.	6 lbs. 5 oz.	7 lbs. 10 oz.	9 lbs. 2 oz.	10 lbs. 5 oz.	
Condensate drain size (fpt) - in.			3/4	3/4	3/4	3/4	3/4	3/4	
Outdoor Coil Fan	Motor horsepower		1/5	1/5	1/5	1/4	1/4	1/4	
	Diameter - in. & No. of blades		22 - 2	22 - 2	22 - 2	26 - 3	26 - 3	26 - 3	
Indoor Blower	Blower wheel size dia. x width - in.		10 x 6	10 x 6	10 x 8	10 x 10	10 x 10	10 x 10	
	Motor horsepower		1/2	1/2	1/2	3/4	3/4	3/4	
Net weight of basic unit			390	390	415	560	570	595	
Shipping weight of basic unit (1 Pkg.)			435	435	460	615	625	650	
Electrical characteristics (60 hz)			208/230V-1ph-60hz						
OPTIONAL ACCESSORIES - MUST BE ORDERED EXTRA									
Compressor Crankcase Heater		93M04	•	•	•	•	•	•	
Compressor Hard Start Kit		10J42	•	•	•	•	•		
Compressor Hard Start Kit		81J69						•	
Compressor Timed-Off Control		47J27	•	•	•	•	•	•	
Electric Heat Size 208/240V-1ph	5 kW - PHK05BP	10W47	•	•	•	•	•	•	
	7.5 kW - PHK07BP	10W48	•	•	•	•	•	•	
	10 kW - PHK10BP	10W49	•	•	•	•	•	•	
	15 kW - PHK15CP	10W50	---	---	•	•	•	•	
	20 kW - PHK20CP	10W51	---	---	---	•	•	•	
³ Internal Filter Kit	(1 ea) 20 x 25 filter	X8131	•	•	•				
	(2 ea) 16 x 25 filter	X8132				•	•	•	
MERV Filters for Internal Filter Kit 5 in. thick	MERV 10	X6673	•	•	•				
		X6670				•	•	•	
	MERV 16	X6675	•	•	•				
		X6672				•	•	•	
Lifting Brackets		92M51	•	•	•	•	•	•	
Low Ambient Kit		24H77	•	•	•	•	•	•	
Roof Curbs	8 inch height	92M99	•	•	•				
		93M01				•	•	•	
	14 inch height	93M00	•	•	•				
		93M02				•	•	•	
Single Point Power Kits	ASPWR813-01 For 5 kW Electric Heat	13W88	•	•	•	•	•	•	
	ASPWR814-01 For 7.5 kW Electric Heat	13W89	•	•	•	•	•	•	
	ASPWR815-01 For 10 kW Electric Heat	13W90	•	•	•	•	•	•	
	ASPWR816-01 For 15-20 kW Electric Heat	13W91	---	---	•	•	•	•	

¹ Rated in accordance with ARI Standard 210/240; 95°F (35°C) outdoor air temperature, 80°F (27°C) db / 67°F (19°C) wb entering evaporator air.

² Sound Rating Number rated in accordance with test conditions included in ARI Standard 270.

³ Filters are not furnished and must be field provided. MERV 10 and MERV 16 filters can be use or other 1, 2, 4 or 5 inch thick filters can be used.

ELECTRIC HEAT CAPACITIES

Input Voltage	5 kW			7.5 kW			10 kW			15 kW			20 kW		
	No of Steps	kW input	Btuh Output	No of Steps	kW input	Btuh Output	No of Steps	kW input	Btuh Output	No of Steps	kW input	Btuh Output	No of Steps	kW input	Btuh Output
208	1	3.8	12,800	1	5.6	19,200	1	7.5	25,600	1	11.2	38,200	1	15.0	51,200
220	1	4.2	14,300	1	6.3	21,500	1	8.4	28,700	1	12.6	43,000	1	16.8	57,300
230	1	4.6	15,700	1	6.9	23,500	1	9.2	31,300	1	13.8	47,000	1	18.4	62,700
240	1	5.0	17,100	1	7.5	25,600	1	10.0	34,100	1	15.0	51,200	1	20.0	68,200

ELECTRICAL/ELECTRIC HEAT DATA

Model No.		13CHAA-24		13CHAA-30		13CHAA-36		
Line voltage data - 60hz 1 phase		208/230V		208/230V		208/230V		
Compressor	Rated Load Amps	10.4		14.1		14.4		
	Locked Rotor Amps	54		68		77		
Outdoor Fan Motor	Full Load Amps	1.1		1.1		1.1		
	Locked Rotor Amps	2.2		2.2		2.2		
Indoor Blower Motor	Rated Load Amps	2.2		2.2		2.2		
	Locked Rotor Amps	3.8		3.8		3.8		
¹ Maximum Overcurrent Protection	Voltage	208V	240V	208V	240V	208V	240V	
	Unit Only Circuit 1	25	25	30	30	35	35	
	Electric Heat & Blower Motor Circuit	5 kW Circuit 2	30	35	30	35	30	35
		7.5 kW Circuit 2	40	45	40	45	40	45
		10 kW Circuit 2	60	60	60	60	60	60
		15 kW Circuit 2	---	---	---	---	60	60
Circuit 3	---	---	---	---	25	30		
¹ Maximum Overcurrent Protection with Optional Single Point Power Supply	5 kW	30	35	30	35	35	35	
	7.5 kW	40	45	40	45	40	45	
	10 kW	60	60	60	60	60	60	
	15 kW	---	---	---	---	80	90	
² Minimum Circuit Ampacity	Unit Only Circuit 1	19	19	23	23	23	23	
	Electric Heat & Blower Motor Circuit	5 kW Circuit 2	27.8	31.3	27.8	31.3	27.8	31.3
		7.5 kW Circuit 2	39.1	44.3	39.1	44.3	39.1	44.3
		10 kW Circuit 2	50.4	57.3	50.4	57.3	50.4	57.3
		15 kW Circuit 2	---	---	---	---	50.4	57.3
	Circuit 3	---	---	---	---	22.6	26.0	
² Minimum Circuit Ampacity with Optional Single Point Power Supply	5 kW	27.8	31.3	27.8	31.3	27.8	31.3	
	7.5 kW	39.1	44.3	39.1	44.3	39.1	44.3	
	10 kW	50.4	57.3	50.4	57.3	50.4	57.3	
	15 kW	---	---	---	---	73.0	83.4	

NOTE - Circuit 1 Minimum Circuit Ampacity includes the Blower Motor Full Load Amps.

NOTE - Extremes of operating range are plus and minus 10% of line voltage.

¹ HACR type breaker or fuse.

² Refer to National or Canadian Electrical Code manual to determine wire, fuse and disconnect size requirements.

ELECTRICAL/ELECTRIC HEAT DATA

Model No.		13CHAA-42		13CHAA-48		13CHAA-60		
Line voltage data - 60hz 1 phase		208/230V		208/230V		208/230V		
Compressor	Rated Load Amps	19.2		19.2		19.9		
	Locked Rotor Amps	104		97		137		
Outdoor Fan Motor	Full Load Amps	1.7		1.7		1.7		
	Locked Rotor Amps	4		4		4		
Indoor Blower Motor	Rated Load Amps	3.6		3.6		3.6		
	Locked Rotor Amps	11		11		11		
¹ Maximum Overcurrent Protection	Voltage	208V	240V	208V	240V	208V	240V	
	Unit Only Circuit 1	45	45	45	45	45	45	
	Electric Heat & Blower Motor Circuit	5 kW Circuit 2	30	35	30	35	30	35
		7.5 kW Circuit 2	45	50	45	50	45	50
		10 kW Circuit 2	60	60	60	60	60	60
		15 kW Circuit 2	60	60	60	60	60	60
		Circuit 3	25	30	25	30	25	30
		20 kW Circuit 2	60	60	60	60	60	60
	Circuit 3	50	60	50	60	50	60	
¹ Maximum Overcurrent Protection with Optional Single Point Power Supply	5 kW	45	45	45	45	45	45	
	7.5 kW	45	50	45	50	45	50	
	10 kW	60	60	60	60	60	60	
	15 kW	80	90	80	90	80	90	
	20 kW	100	125	100	125	100	125	
² Minimum Circuit Ampacity	Unit Only Circuit 1	31.0	31.0	31.0	31.0	32.0	32.0	
	Electric Heat & Blower Motor Circuit	5 kW Circuit 2	29.6	33.0	29.6	33.0	29.6	33.0
		7.5 kW Circuit 2	40.9	46.1	40.9	46.1	40.9	46.1
		10 kW Circuit 2	52.1	59.1	52.1	59.1	52.1	59.1
		15 kW Circuit 2	52.1	59.1	52.1	59.1	52.1	59.1
		Circuit 3	22.6	26.0	22.6	26.0	22.6	26.0
		20 kW Circuit 2	52.1	59.1	52.1	59.1	52.1	59.1
		Circuit 3	45.1	52.1	45.1	52.1	45.1	52.1
² Minimum Circuit Ampacity with Optional Single Point Power Supply	5 kW	31.0	33.0	31.0	33.0	32.0	33.0	
	7.5 kW	40.9	46.1	40.9	46.1	40.9	46.1	
	10 kW	52.1	59.1	52.1	59.1	52.1	59.1	
	15 kW	74.7	85.1	74.7	85.1	74.7	85.1	
	20 kW	97.3	111.2	97.3	111.2	97.3	111.2	

NOTE - Circuit 1 Minimum Circuit Ampacity includes the Blower Motor Full Load Amps.

NOTE - Extremes of operating range are plus and minus 10% of line voltage.

¹ HACR type breaker or fuse.

² Refer to National or Canadian Electrical Code manual to determine wire, fuse and disconnect size requirements.

FIELD WIRING

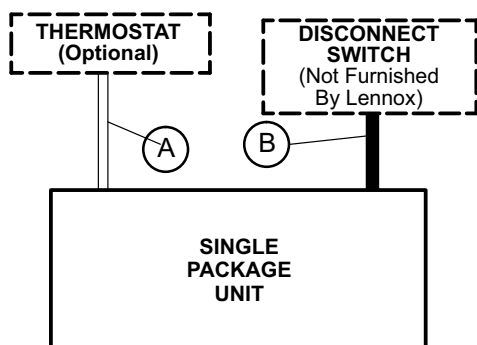

A- Four Wire Low Voltage (Electro-mechanical)

- Five Wire Low Voltage (Electronic)

B- Two Wire Power (See Electrical Data Table)

If multiple disconnects are used on units with electric heat, there must be two-wire power provided for each disconnect

- Field Wiring Not Furnished -

NOTE - All wiring must conform to NEC or CEC and local electrical codes.

BLOWER DATA

13CHAA-24-30 BLOWER PERFORMANCE

¹ Horizontal Air Flow

External Static Pressure		Air Volume at Various Blower Speeds					
		High		Medium		Low	
in. w.g.	Pa	cfm	L/s	cfm	L/s	cfm	L/s
.20	50	1470	695	1070	505	880	415
.30	75	1420	670	1060	500	870	410
.40	100	1360	640	1020	480	850	400
.50	125	1290	610	1000	470	820	385
.60	150	1220	575	950	450	790	375
.70	175	1140	540	900	425	740	350
.80	200	1050	495	830	390	690	325

NOTE - All air data is measured external to unit without air filters.

¹ For down-flow air volume, add 0.05 in. w.g. (12 Pa) to duct static.

13CHAA-36 BLOWER PERFORMANCE

¹ Horizontal Air Flow

External Static Pressure		Air Volume at Various Blower Speeds					
		High		Medium		Low	
in. w.g.	Pa	cfm	L/s	cfm	L/s	cfm	L/s
.20	50	1510	715	1060	500	870	410
.30	75	1460	690	1050	495	860	405
.40	100	1400	660	1030	485	840	395
.50	125	1330	630	990	465	820	385
.60	150	1250	590	950	450	790	375
.70	175	1180	555	900	425	750	355
.80	200	1100	520	850	400	680	320

NOTE - All air data is measured external to unit without air filters.

¹ For down-flow air volume, add 0.05 in. w.g. (12 Pa) to duct static.

13CHAA-42-48-60 BLOWER PERFORMANCE

¹ Horizontal Air Flow

External Static Pressure		Air Volume at Various Blower Speeds					
		High		Medium		Low	
in. w.g.	Pa	cfm	L/s	cfm	L/s	cfm	L/s
.20	50	2090	985	1820	860	1520	715
.30	75	2000	945	1780	840	1480	700
.40	100	1930	910	1730	815	1450	685
.50	125	1820	860	1650	780	1440	680
.60	150	1710	805	1570	740	1410	665
.70	175	1590	750	1480	700	1360	640
.80	200	1480	700	1370	645	1260	595

NOTE - All air data is measured external to unit without air filters.

¹ For down-flow air volume, add 0.05 in. w.g. (12 Pa) to duct static.

INSTALLATION CLEARANCES - INCHES (MM)

NOTE - Top Clearance - 36 in. (914 mm)

NOTE - Entire perimeter of unit base requires support when elevated above mounting surface

¹ Maintain 18 in. (457 mm) service clearance for accessory maintenance if equipped.

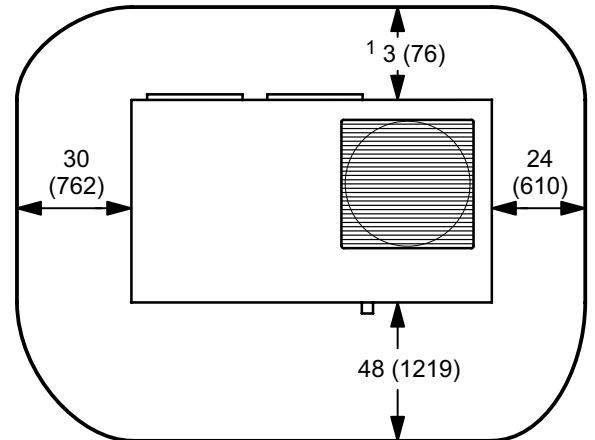

DIMENSIONS - INCHES (MM)

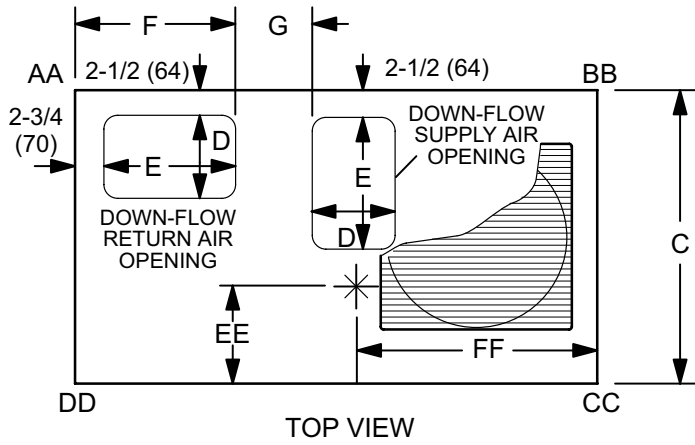

Model Number	Corner Weights				Center of Gravity	
	AA lbs.	BB lbs.	CC lbs.	DD lbs.	EE in.	FF in.
13CHAA-24	73	91	114	92	16	29
13CHAA-30	73	91	114	92	16	29
13CHAA-36	80	93	117	100	16	30
13CHAA-42	102	128	151	120	21	33
13CHAA-48	105	129	152	124	21	33.5
13CHAA-60	105	129	152	124	21	33.5

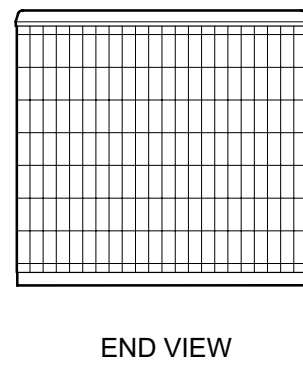
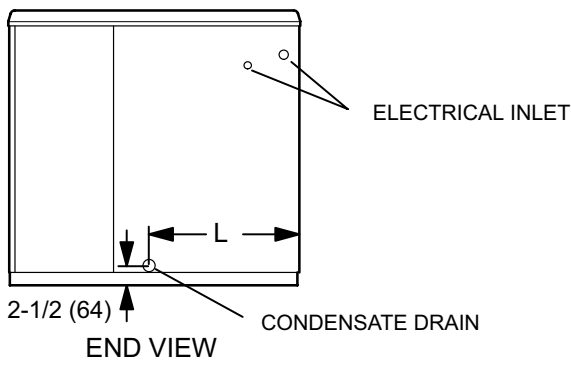
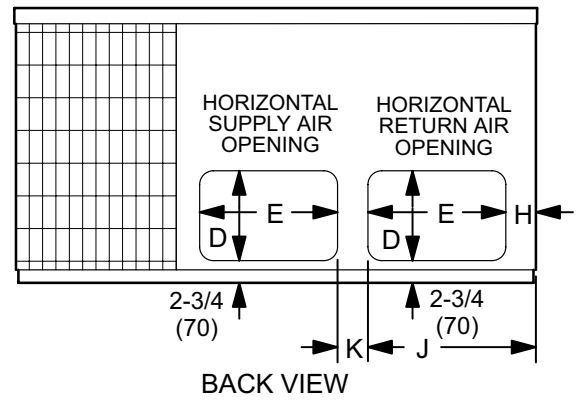
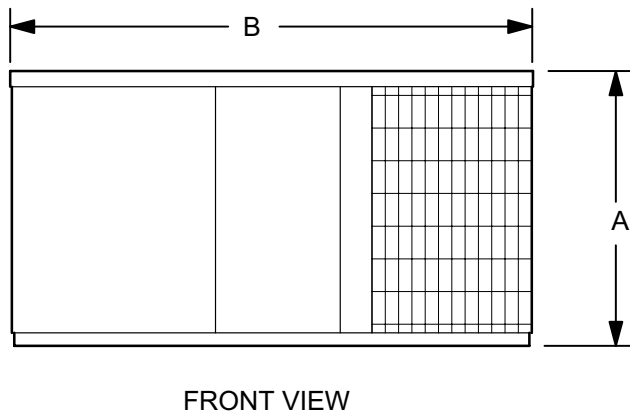

Model No.	A		B		C		D		E	
	in.	mm	in.	mm	in.	mm	in.	mm	in.	mm
13CHAA-24										
13CHAA-30	34-1/4	870	65-3/8	1661	36-1/2	927	11-1/4	286	17-1/4	438
13CHAA-36										
13CHAA-42										
13CHAA-48	38-1/4	972	75	1905	46	1168	11-1/4	286	19-1/4	489
13CHAA-60										

Model No.	F		G		H		J		K		L	
	in.	mm	in.	mm	in.	mm	in.	mm	in.	mm	in.	mm
13CHAA-24												
13CHAA-30	20	508	8-1/2	216	3	76	20-1/4	514	4-1/2	114	19	483
13CHAA-36												
13CHAA-42												
13CHAA-48	22	559	9-1/4	241	3-1/4	83	22-1/4	572	4	102	16-1/4	413
13CHAA-60												

ACCESSORY DIMENSIONS - INCHES (MM)

ROOF CURBS

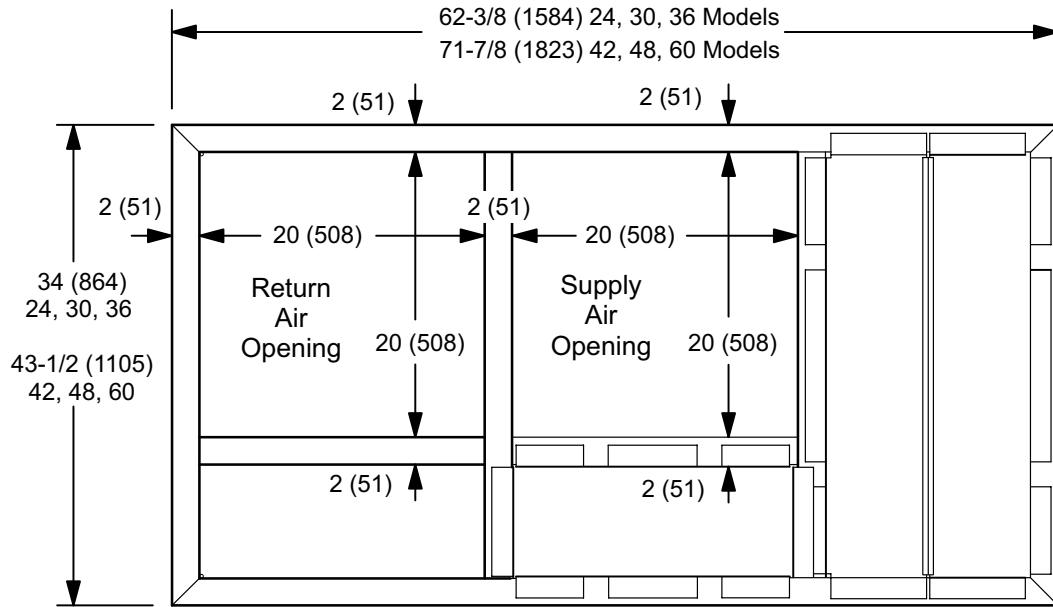

TOP VIEW



SIDE VIEW

REVISIONS

Sections	Description of Change
Electrical/Electric Heat Data	Added 208V and Optional Single Point Power Supply information.
Optional Accessories	Added new Internal Filter Kits and MERV filters



Visit us at www.lennox.com
For the latest technical information, www.lennox.com
Contact us at 1-800-4-LENNOX

NOTE - Due to Lennox' ongoing commitment to quality, Specifications, Ratings and Dimensions subject to change without notice and without incurring liability. Improper installation, adjustment, alteration, service or maintenance can cause property damage or personal injury. Installation and service must be performed by a qualified installer and servicing agency.

©2007 Lennox Industries Inc.