

**SEER - 13.00**  
**2 to 2.5 Tons**  
**Cooling Capacity - 23,000 to 28,800 Btuh**  
**Input Gas Heating Capacity - 67,500 Btuh**

**MODEL NUMBER IDENTIFICATION**

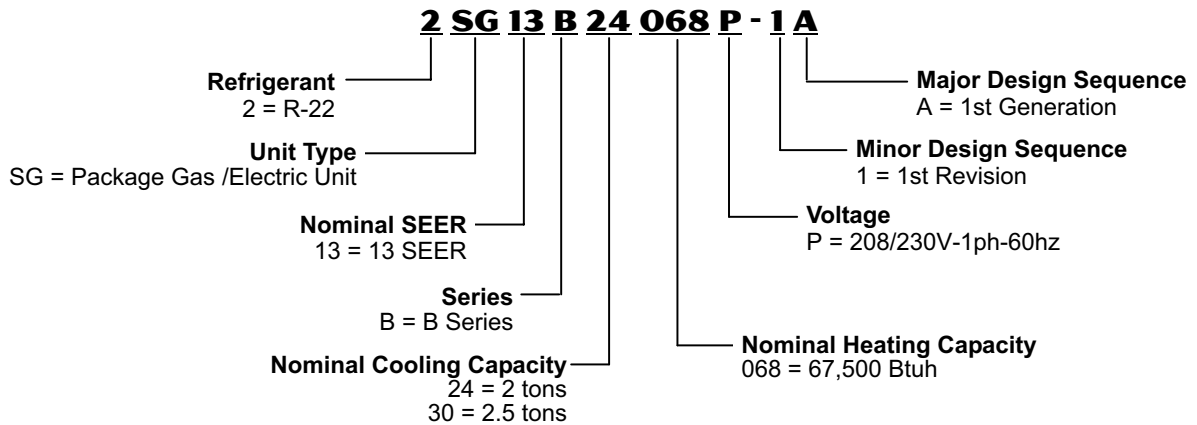

## FEATURES

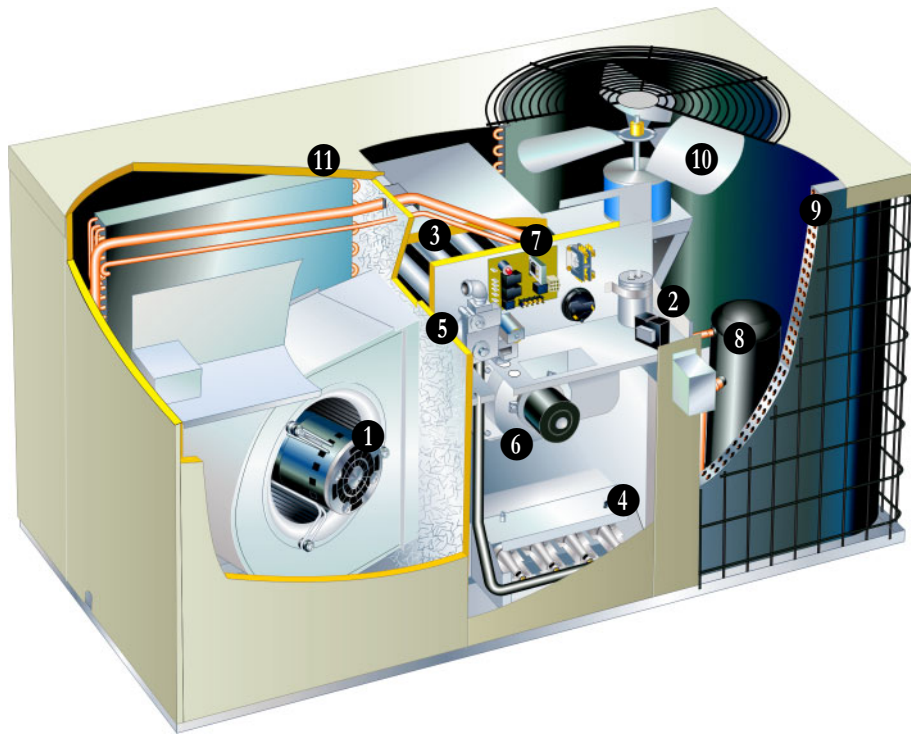

### **CONTENTS**

Blower Data .....	Page 7
Control Systems .....	Page 8
Dimensions .....	Page 9
Dimensions - Accessories .....	Page 10 - 11
Electrical Data .....	Page 6
Expanded Cooling Ratings .....	Page 6
Features .....	Pages 2-4
High Altitude Derate Information .....	Page 5
Installation Clearances .....	Page 7
Model Number Identification .....	Page 1
Optional Accessories .....	Page 4
Specifications .....	Page 5

### **CERTIFICATIONS**

Units are design certified by UL.  
Heating ratings are according to Department of Energy (DOE) test procedures and Federal Trade Commission (FTC) labeling regulations and are certified by GAMA.  
Low NO<sub>x</sub> "X" models meet California Nitrogen Oxides (NO<sub>x</sub>) standards.  
Cooling system rated according to DOE test procedures.  
Cooling system rated in accordance with ARI standard 210/240.  
Units are listed by UL for the U.S. and Canada.  
Packaged unit and components within bonded for grounding to meet safety standards required by UL.  
Each unit test operated at the factory before shipment ensuring dependable operation at start-up.

### **WARRANTY**

**Heat Exchanger** - Limited warranty for **ten years**.

**Compressor** - Limited warranty for **five years**.

**All other covered components** - **one year**.

### **APPLICATIONS**

Designed for outdoor installations at ground level or rooftop.

### **BLOWER**

#### **1 Direct Drive Blower**

Each blower assembly statically and dynamically balanced.

Blower assembly easily removed for servicing.

Multi-speed, direct drive blower motor.

Change in blower speed is easily accomplished by simple wiring change on blower motor.

See Blower Performance tables.

### **CONTROLS**

#### **2 24 Volt Transformer**

40VA transformer furnished and factory installed in control area.

#### **Economizer Wiring Harness**

Wiring harness for optional economizer furnished with unit.

### **OPTIONS**

#### **Low Ambient Kit**

Air conditioners operate satisfactorily down to 45°F outdoor air temperature without any additional controls.

Low Ambient Control Kit can be field installed, allowing unit operation down to 30°F.

#### **Thermostat**

See Thermostat bulletins in Controls section and Lennox Price Book for a complete list of thermostats.

## FEATURES

### HEATING SYSTEM

#### 3 Heat Exchanger

Aluminized tubular steel for superior resistance to corrosion and oxidation.

Round surfaces create minimum air resistance and allow air to surround all surfaces for excellent heat transfer.

Compact design reduces space requirements in unit cabinet.

Heat exchanger has been laboratory life cycle tested.

#### 4 Inshot Burners

Aluminized steel inshot burners provide efficient trouble free operation.

Burner venturi mixes air and gas in correct proportion for proper combustion.

Burner assembly is removeable from the unit as a single component for ease of service and each burner may be removed individually.

#### 5 Gas Control Valve

24 volt redundant combination gas control valve combines manual shut off valve (On-Off), automatic electric valve (dual) and gas pressure regulation into a compact combination control.

#### 6 Combustion Air Inducer

Heavy duty combustion air inducer prepurges heat exchanger and safely vents flue products.

Blower is controlled by the ignition control board.

Pressure switch proves blower operation before allowing gas valve to open.

Combustion air inducer operates during heating cycle. Inducer also operates for the first 10 seconds of every cooling cycle to prevent insects from nesting in the flue outlet during cooling season.

#### Limit Controls

Automatic reset, primary and secondary limits are accurately located.

Primary limit factory installed on heating vestibule panel.

#### Flame Rollout Switch

Manual reset switch is factory installed on burner box.

Switch provides protection from abnormal operating conditions.

#### 7 Ignition Control Board

Solid-state ignition control board with LED diagnostics.

### OPTIONS

#### LPG/Propane Conversion Kit

Required for field changeover from natural gas to LPG/Propane.

### COOLING SYSTEM

#### 8 COPELAND SCROLL™ COMPRESSOR

Compressor features high efficiency with uniform suction flow, constant discharge flow and high volumetric efficiency and quiet operation.

Compressor consists of two involute spiral scrolls matched together to generate a series of crescent shaped gas pockets between them.

During compression, one scroll remains stationary while the other scroll orbits around it.

Gas is drawn into the outer pocket, the pocket is sealed as the scroll rotates.

As the spiral movement continues, gas pockets are pushed to the center of the scrolls. Volume between the pockets is simultaneously reduced.

When pocket reaches the center, gas is now at high pressure and is forced out of a port located in the center of the fixed scrolls.

During compression, several pockets are compressed simultaneously resulting in a smooth continuous compression cycle.

Continuous flank contact, maintained by centrifugal force, minimizes gas leakage and maximizes efficiency.

Scroll compressor is tolerant to the effects of slugging and contaminants. If this occurs, scrolls separate, allowing liquid or contaminants to be worked toward the center and discharged.

Low gas pulses during compression reduces operational sound levels.

Compressor motor is internally protected from excessive current and temperature.

Compressor is installed in the unit on resilient rubber mounts for vibration free operation.

#### 9 Evaporator and Condenser Coils

Copper tube with aluminum fin coils.

#### Evaporator Coil Drain Pan

Corrosion resistant plastic drain pan.

#### 10 Condenser Fan

Weather protected heavy duty condenser fan motor with coated steel fan blades for long life.

Internally mounted.

Totally enclosed motor.

Fan guard constructed of corrosion-resistant PVC (polyvinyl chloride) coated steel.

### OPTIONS

#### Compressor Crankcase Heater

Protects against refrigerant migration that can occur during low ambient operation.

#### Compressor Hard Start Kit

Single-phase units are equipped with a PSC compressor motor. This type of motor normally doesn't need a potential relay and start capacitor.

In conditions such as low voltage, this kit may be required to increase the compressor starting torque.

#### Compressor Timed-Off Control

Kit prevents compressor short-cycling and allows time for suction and discharge pressure to equalize.

Permits compressor start-up in an unloaded condition.

Automatic reset with 5 minute delay between compressor shut-off and start-up.

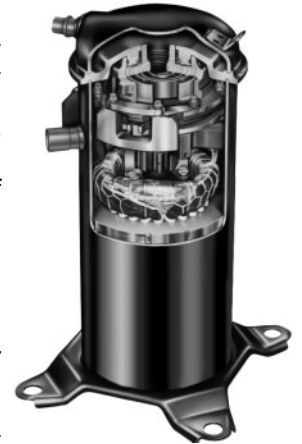

## FEATURES

### CABINET

- ① Conditioned areas insulated with foil faced insulation to minimize heat loss and reduce operating sound levels.  
Powder paint for maximum durability.

Easy service access.

PVC coated steel wire coil guard furnished as standard.

Interchangeable panels for horizontal to down-flow airflow conversion furnished (shipped for horizontal).

### Gas Piping Inlets, Electrical Inlets and Service Valves

#### Valves

Gas piping and field wiring inlets are located in one central area of the cabinet. See dimension drawing.

Gauge ports are located inside the cabinet.

### OPTIONS

#### Lifting Brackets

Available to facilitate rigging of the unit.

### AIR FILTER OPTIONS (REQUIRED)

Filters are not furnished - must be field provided.

#### Internal Filter Kits

Available for 1, 2, or 4 in. thick filters. Kit contains filter rails for mounting filters internal to unit. Filters must be field provided.

### ROOF CURBS, DOWN-FLOW

Mates to unit.

Shipped knocked down.

Available in 8 in. and 14 in. heights. See dimension drawings.

Cliplock curbs use interlocking tabs to fasten together. No tools required. Nail strip furnished. Gasket furnished for seal around perimeter of curb to unit.

Hinged curb corners fasten together with hinge pins.

## ECONOMIZER / OUTDOOR AIR / EXHAUST

### OPTIONS

#### Economizer (Down-Flow or Horizontal Models)

Motor driven return air and outdoor air dampers, sleeve bearings, neoprene seals, 24 volt, spring return motor, adjustable minimum damper position.

Mixed air sensor and fresh air sensor furnished.

Economizer assembly attaches to side of unit.

See dimension drawings.

Solid-state, single enthalpy control.

Modulating economizer control.

Hood with metal mesh filter and internal divider panel (down-flow model) furnished.

NOTE - Down-flow economizer requires AFILT807-1 Internal Filter Kit (ordered separately) and field provided filter.

Horizontal economizer has filter rack factory installed (filter must be field provided).

#### Outdoor Air Damper - Manual or Motorized

Damper assembly replaces panel on side of unit.

See dimension drawing.

Manually adjustable slide damper, 0 to 35% outdoor air.

Motorized version also includes 2-position intake damper with 24 volt damper motor.

Intake damper is fully insulated.

Outdoor air hood furnished.

May be used in horizontal or down-flow applications.

NOTE - Requires AFILT807-1 Internal Filter Kit (ordered separately) and field provided filter.

## OPTIONS / ACCESSORIES

Item		2SG13B24	2SG13B30
<b>CONTROLS</b>			
Low Ambient Kit	24H77	x	x
<b>COOLING SYSTEM</b>			
Compressor Crankcase Heater	93M04	x	x
Compressor Hard Start Kit	10J42	x	x
Compressor Timed-Off Control	47J27	x	x
<b>HEATING SYSTEM</b>			
Gas Heat Input	Standard - 68K	○	○
LPG/Propane Conversion Kit	Standard 68K - ALPKT804-1	x	x
<b>AIR FILTER</b>			
Internal Filter Kit	<sup>1</sup> (1) 20 x 25 - AFILT807-1	x	x
<b>CABINET</b>			
Lifting Brackets	ALIFT801-1	x	x
<b>ECONOMIZERS</b>			
<sup>2</sup> Economizer (Down-Flow) (includes Hood)	AECON817-1	x	x
<sup>3</sup> Economizer (Horizontal) (includes Hood)	AECON818-1	x	x
<b>OUTDOOR AIR DAMPER</b>			
<sup>2</sup> Manual Damper	ADMPR819-1	x	x
<sup>2</sup> Motorized Damper	ADMPR821-1	x	x
<b>ROOF CURBS - CLIPLOCK 1000</b>			
8 inch height	C1CURB23X-1	x	x
14 inch height	C1CURB20X-1	x	x
<b>ROOF CURBS - HINGED</b>			
8 inch height	ACURB809-1	x	x
14 inch height	ACURB810-1	x	x

<sup>1</sup> Filters are not furnished and must be field provided. 1, 2 or 4 inch width filters can be used.

<sup>2</sup> Requires AFILT807-1 Internal Filter Kit (ordered separately) and field provided filter.

<sup>3</sup> Filter for Horizontal Economizer (20 x 25 in.) must be field provided. 1, 2 or 4 in. width filters can be used.

X - Field Installed.

○ - Configure to Order (Factory Installed).

**SPECIFICATIONS****2-2.5 TON**

General Data		Model No.	2SG13B24	2SG13B30
		Nominal Tonnage	2	2.5
<b>Gas Heat Available - See Below</b>			<b>068</b>	<b>068</b>
<b>Cooling Performance</b>	Total cooling capacity - Btuh		23,000	28,800
	Total unit watts		2000	2500
	<sup>1</sup> SEER (Btuh/Watt)		13.00	13.00
	EER (Btuh/Watt)		11.50	11.50
	<sup>2</sup> Sound Rating Number (dB)		81	81
		Refrigerant Type	R-22	R-22
		Refrigerant Charge	6 lbs. 8 oz.	6 lbs. 2 oz.
<b>Condensate drain size (fpt) - in.</b>			3/4	3/4
<b>Condenser Fan</b>	Motor horsepower		1/5	1/5
	Diameter - in. & No. of blades		22 - 2	22 - 2
<b>Evaporator Blower</b>	Blower wheel size diameter x width - in.		10 x 6	10 x 6
	Motor horsepower		1/2	1/2
<b>Net weight of basic unit</b>			390	390
<b>Shipping weight of basic unit (1 Pkg.)</b>			435	435
<b>Electrical characteristics (60 hz)</b>			208/230V-1ph-60hz	

<sup>1</sup>Rated in accordance with ARI Standard 210/240; 95°F outdoor air temperature, 80°F db / 67°F wb entering evaporator air.

<sup>2</sup>Sound Rating Number in accordance with test conditions included in ARI Standard 270.

**SPECIFICATIONS - GAS HEAT**

		Heat Option	068
<b>Heating Capacity - Btuh</b>	Input		67,500
	Output		54,000
	<sup>1</sup> A.F.U.E.		80%
<b>Temperature Rise - °F</b>			35 - 65
<b>Gas Supply Connection (fpt) - in. (mm)</b>			1/2
<b>Minimum Recommended Gas Supply Pressure</b>			7 in. w.g. Natural Gas, 11 in. w.g. LPG/Propane

<sup>1</sup> Annual Fuel Utilization Efficiency based on U.S. DOE test procedures and FTC labeling regulations.

**HIGH ALTITUDE DERATE**

Units may be installed at altitudes up to 4500 feet above sea level without any modification. At altitudes above 4500 feet, units must be derated 4% for every 1000 feet above sea level. (Example - At an altitude of 6000 feet the unit would require a derate of 24%.)

NOTE - This is the only permissible derate for these units.

## COOLING RATINGS

NOTE - For Temperatures and Capacities not shown in tables, see bulletin - Cooling Unit Rating Table Correction Factor Data in Miscellaneous Engineering Data section.

### 2 TON

### 2SG13B24

Entering Wet Bulb Temperature	Total Air Volume		Outdoor Air Temperature Entering Outdoor Coil																							
			85°F (29°C)						95°F (35°C)						105°F (41°C)						115°F (46°C)					
			Total Cooling Capacity		Comp Motor kW Input	Sensible To Total Ratio (S/T) Dry Bulb			Total Cooling Capacity		Comp Motor kW Input	Sensible To Total Ratio (S/T) Dry Bulb			Total Cooling Capacity		Comp Motor kW Input	Sensible To Total Ratio (S/T) Dry Bulb			Total Cooling Capacity		Comp Motor kW Input	Sensible To Total Ratio (S/T) Dry Bulb		
			kBtuh	kW		75°F 24°C	80°F 27°C	85°F 29°C	kBtuh	kW		75°F 24°C	80°F 27°C	85°F 29°C	kBtuh	kW		75°F 24°C	80°F 27°C	85°F 29°C	kBtuh	kW		75°F 24°C	80°F 27°C	85°F 29°C
63°F (17°C)	600	285	22.0	6.4	1.29	0.72	0.85	0.98	20.9	6.1	1.45	0.73	0.86	0.99	19.7	5.8	1.65	0.76	0.90	1.00	18.5	5.4	1.87	0.78	0.92	1.00
	800	380	22.9	6.7	1.30	0.79	0.93	1.00	21.9	6.4	1.47	0.80	0.95	1.00	20.6	6.0	1.67	0.83	0.98	1.00	19.3	5.6	1.89	0.85	1.00	1.00
	1000	470	23.7	6.9	1.32	0.85	1.00	1.00	22.5	6.6	1.48	0.86	1.00	1.00	21.3	6.2	1.68	0.90	1.00	1.00	19.9	5.8	1.91	0.92	1.00	1.00
67°F (19°C)	600	285	23.4	6.9	1.32	0.57	0.69	0.81	22.3	6.5	1.48	0.57	0.70	0.82	21.0	6.2	1.68	0.60	0.73	0.86	19.7	5.8	1.91	0.61	0.75	0.88
	800	380	24.2	7.1	1.32	0.61	0.76	0.90	23.0	6.7	1.48	0.62	0.77	0.92	21.7	6.4	1.68	0.64	0.80	0.95	20.3	5.9	1.91	0.66	0.82	0.98
	1000	470	24.6	7.2	1.32	0.65	0.83	0.98	23.5	6.9	1.48	0.66	0.84	0.99	22.1	6.5	1.68	0.69	0.87	1.00	20.7	6.1	1.91	0.70	0.90	1.00
71°F (22°C)	600	285	24.9	7.3	1.33	0.43	0.54	0.66	23.7	6.9	1.49	0.44	0.55	0.67	22.3	6.5	1.70	0.46	0.57	0.69	20.9	6.1	1.93	0.47	0.59	0.71
	800	380	25.6	7.5	1.33	0.44	0.58	0.73	24.4	7.1	1.49	0.45	0.59	0.74	23.0	6.7	1.70	0.47	0.62	0.77	21.5	6.3	1.93	0.48	0.63	0.79
	1000	470	26.1	7.6	1.34	0.47	0.64	0.81	24.8	7.3	1.51	0.47	0.65	0.82	23.4	6.9	1.72	0.49	0.67	0.85	21.9	6.4	1.95	0.50	0.69	0.87

### 2.5 TON

### 2SG13B30

Entering Wet Bulb Temperature	Total Air Volume		Outdoor Air Temperature Entering Outdoor Coil																							
			85°F (29°C)						95°F (35°C)						105°F (41°C)						115°F (46°C)					
			Total Cooling Capacity		Comp Motor kW Input	Sensible To Total Ratio (S/T) Dry Bulb			Total Cooling Capacity		Comp Motor kW Input	Sensible To Total Ratio (S/T) Dry Bulb			Total Cooling Capacity		Comp Motor kW Input	Sensible To Total Ratio (S/T) Dry Bulb			Total Cooling Capacity		Comp Motor kW Input	Sensible To Total Ratio (S/T) Dry Bulb		
			kBtuh	kW		75°F 24°C	80°F 27°C	85°F 29°C	kBtuh	kW		75°F 24°C	80°F 27°C	85°F 29°C	kBtuh	kW		75°F 24°C	80°F 27°C	85°F 29°C	kBtuh	kW		75°F 24°C	80°F 27°C	85°F 29°C
63°F (17°C)	800	375	27.5	8.1	1.70	0.71	0.84	0.97	26.2	7.7	1.91	0.72	0.85	0.98	24.7	7.2	2.17	0.75	0.88	1.00	23.1	6.8	2.47	0.77	0.91	1.00
	1000	470	28.7	8.4	1.72	0.78	0.92	1.00	27.4	8.0	1.93	0.79	0.93	1.00	25.8	7.6	2.19	0.82	0.97	1.00	24.1	7.1	2.49	0.84	1.00	1.00
	1200	565	29.6	8.7	1.74	0.84	0.99	1.00	28.2	8.3	1.95	0.85	1.00	1.00	26.6	7.8	2.22	0.89	1.00	1.00	24.9	7.3	2.52	0.91	1.00	1.00
67°F (19°C)	800	375	29.3	8.6	1.74	0.56	0.68	0.80	27.9	8.2	1.95	0.57	0.69	0.81	26.4	7.7	2.22	0.59	0.72	0.85	24.6	7.2	2.52	0.60	0.74	0.87
	1000	470	30.2	8.9	1.74	0.60	0.75	0.89	28.8	8.4	1.95	0.61	0.76	0.90	27.2	8.0	2.22	0.63	0.79	0.94	25.4	7.4	2.52	0.65	0.81	0.96
	1200	565	30.8	9.0	1.74	0.64	0.82	0.96	29.4	8.6	1.95	0.65	0.83	0.98	27.7	8.1	2.22	0.68	0.86	1.00	25.9	7.6	2.52	0.69	0.88	1.00
71°F (22°C)	800	375	31.1	9.1	1.75	0.43	0.54	0.65	29.7	8.7	1.97	0.43	0.54	0.66	28.0	8.2	2.24	0.45	0.57	0.69	26.2	7.7	2.54	0.46	0.58	0.70
	1000	470	32.1	9.4	1.75	0.44	0.58	0.72	30.5	8.9	1.97	0.44	0.59	0.73	28.8	8.4	2.24	0.46	0.61	0.76	26.9	7.9	2.54	0.47	0.62	0.78
	1200	565	32.7	9.6	1.77	0.46	0.63	0.80	31.1	9.1	1.99	0.47	0.64	0.81	29.3	8.6	2.26	0.48	0.66	0.84	27.4	8.0	2.57	0.50	0.68	0.86

## ELECTRICAL DATA

General Data	Model No.	2SG13B24	2SG13B30
	Line voltage data - 60hz 1 phase		208/230V
<sup>1</sup> Maximum overcurrent protection (amps)		20	25
<sup>2</sup> Minimum Circuit Ampacity		19	23
Compressor	Rated load amps	10.4	14.1
	Locked rotor amps	45	68
Condenser Fan Motor	Full load amps	1.1	1.1
	Locked rotor amps	2.2	2.2
Indoor Blower Motor	Full load amps	2.2	2.2
	Locked rotor amps	3.8	3.8

<sup>1</sup> HACR type breaker or fuse.

<sup>2</sup> Refer to National or Canadian Electrical Code manual to determine wire, fuse and disconnect size requirements. Use wires suitable for at least 167°F.

## BLOWER DATA

### 2SG13B24, 2SG13B30 BLOWER PERFORMANCE Down-Flow Airflow

External Static Pressure in. w.g.	Air Volume at Various Blower Speeds (cfm)		
	High	Medium	Low
.20	1480	1070	880
.30	1450	1060	870
.40	1390	1040	860
.50	1320	1010	840
.60	1260	970	800
.70	1180	920	760
.80	1100	860	710

NOTE - All air data is measured external to unit without air filters.

### 2SG13B24, 2SG13B30 BLOWER PERFORMANCE Horizontal Airflow

External Static Pressure in. w.g.	Air Volume at Various Blower Speeds (cfm)		
	High	Medium	Low
.20	1470	1070	880
.30	1420	1060	870
.40	1360	1020	850
.50	1290	1000	820
.60	1220	950	790
.70	1140	900	740
.80	1050	830	690

NOTE - All air data is measured external to unit without air filters.

## INSTALLATION CLEARANCES - INCHES (MM)

### BASIC UNIT

NOTE - Top Clearance - 36 in. (914 mm)  
NOTE - Entire perimeter of unit base requires support when elevated above mounting surface

<sup>1</sup> Maintain 18 in. (457mm) service clearance for accessory maintenance if equipped.

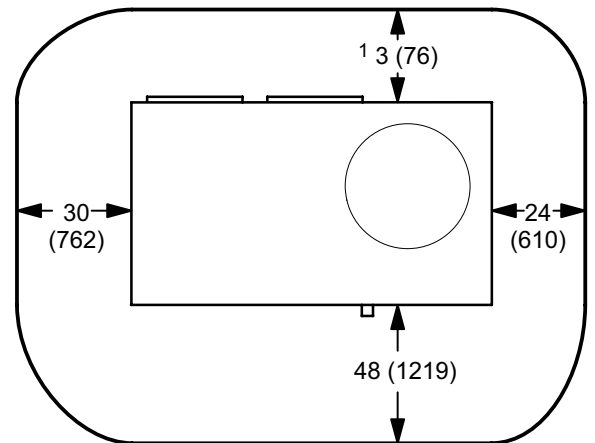

### BASIC UNIT WITH OPTIONAL ECONOMIZER

NOTE - Top Clearance - 36 in. (914 mm)  
NOTE - Entire perimeter of unit base requires support when elevated above mounting surface

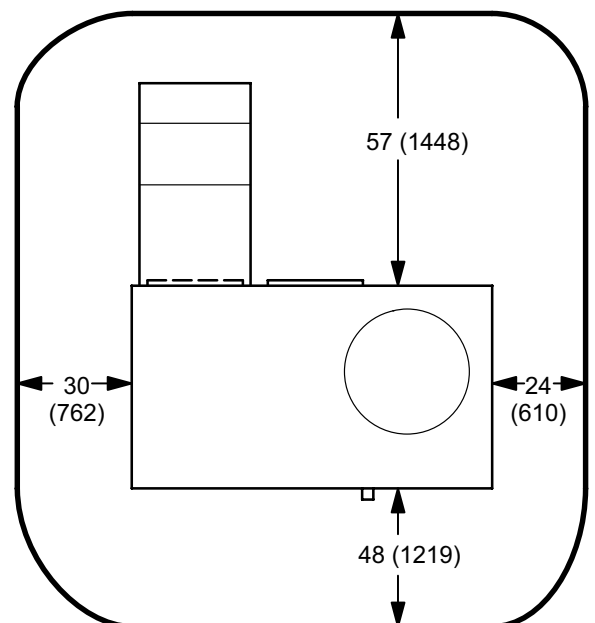

## OPTIONAL CONVENTIONAL TEMPERATURE CONTROL SYSTEMS - FIELD INSTALLED

### COMMERCIAL TOUCHSCREEN THERMOSTAT



Intuitive Touchscreen Interface - **Two Stage Heating / Two Stage Cooling Conventional or Heat Pump** - Seven Day Programmable - Four Time Periods/Day - Economizer Output - Title 24 Compliant - ENERGY STAR® Qualified - Backlit Display - Automatic Changeover

C0STAT02AE1L

#### Sensors For Touchscreen Thermostat

1 Remote non-adjustable wall mount 20k temperature sensor .....	C0SNZN01AE1-
1 Remote non-adjustable wall mount 10k averaging temperature sensor .....	C0SNZN73AE1-
1 Remote non-adjustable duct mount temperature sensor .....	C0SNDC00AE1-
Outdoor temperature sensor .....	C0SNSR03AE1-

<sup>1</sup> Remote sensors for C0STAT02AE1L can be applied in the following combinations: (1) C0SNZN01AE1-, (2) C0SNZN73AE1-, (2) C0SNZN01AE1- and (1) C0SNZN73AE1-, (4) C0SNZN01AE1-, (3) C0SNZN01AE1- and (2) C0SNZN73AE1.

### DIGITAL PROGRAMMABLE THERMOSTAT



Intuitive Pushbutton Interface - Seven Day Programmable - Four Time Periods/Day - Economizer Output - Automatic Changeover (requires subbase, ordered separately)

C0STAT00AE1L

#### Subbases For Digital Programmable Thermostat

<b>Three stage heating / cooling</b> conventional subbase .....	C0STAT43AE1L
LonMark® certified communicating capability, <b>three stage heating/cooling</b> conventional subbase	C0STAT45AE1L

#### Sensors For Digital Programmable Thermostat

Remote wall mount temperature sensor with setpoint adjustment .....	C0SNZN02AE1-
<sup>1</sup> Remote wall mount temperature sensor with three hour override button, override status LED, and setpoint adjustment	C0SNZN06AE1-
<sup>2</sup> Remote wall mount averaging temperature sensor .....	C0SNZN72AE1-
<sup>1, 2</sup> Remote wall mount averaging temperature sensor .....	C0SNZN72AE1-
Remote duct mount return air temperature sensor .....	C0SNDC01AE1-

#### Accessories For Digital Programmable Thermostat

Locking cover (clear) .....	C0MISC15AE1-
-----------------------------	--------------

#### NOTES

<sup>1</sup> In averaging sensor applications, one C0SNZN06AE1- sensor can replace one C0SNZN72AE1- sensor (only one C0SNZN06AE1- can be used per thermostat)  
<sup>2</sup> Remote averaging sensors can be used in the following combinations: (1) C0SNZN72AE1-, (2) C0SNZN72AE1-, (2) C0SNZN72AE1- and (1) C0SNZN72AE1-, (4) C0SNZN72AE1-, (5) C0SNZN72AE1-, or (9) C0SNZN72AE1-.

### DIGITAL NON-PROGRAMMABLE THERMOSTATS



Intuitive Interface - Automatic Changeover - Simple Up and Down Temperature Control

<b>Two-stage heating / cooling</b> conventional systems .....	C0STAT10AE1L
---	--------------

#### Sensor For Digital Non-Programmable Thermostats Above

Remote wall mounted temperature sensor .....	C0SNZN00AE1-
--	--------------

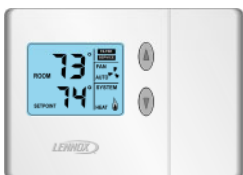

Intuitive Interface - Automatic Changeover - Backlit Display - Simple Up and Down Temperature Control

<b>One-stage heating / cooling</b> conventional systems .....	C0STAT12AE1L
---	--------------

#### Sensor For Digital Non-Programmable Thermostats Above

Outdoor temperature sensor .....	C0SNSR04AE1-
----------------------------------	--------------

#### Accessories For Digital Non-Programmable Thermostats Above

Optional wall mounting plate .....	C0MISC17AE1-
------------------------------------	--------------



# DIMENSIONS - INCHES (MM)

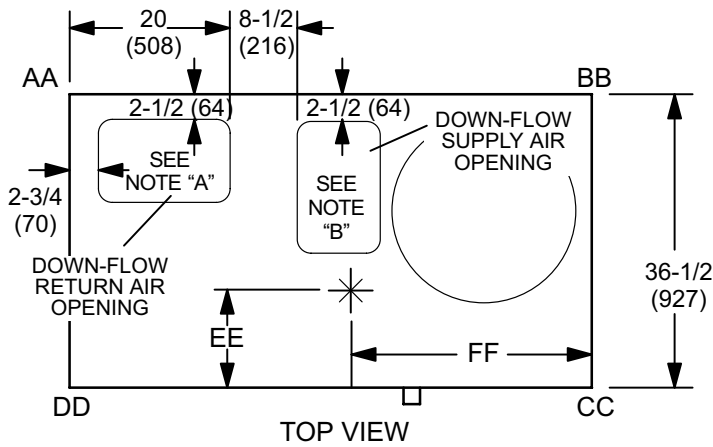

Model	Corner Weights				Center Of Gravity							
	AA		BB		CC		DD		EE		FF	
	lbs.	kg	lbs.	kg	lbs.	kg	lbs.	kg	in.	mm	in.	mm
24	74	34	94	43	125	57	97	44	15.5	394	28.5	724
30												

## OPENING SIZES

NOTE A - Down-Flow Return Air Opening  
17-1/4 (286) x 11-1/4 (286)

NOTE B - Down-Flow Supply Air Opening  
11-1/4 (286) x 17-1/4 (286)

NOTE C - Horizontal Supply and Return Air Openings  
17-1/4 (286) x 11-1/4 (286)

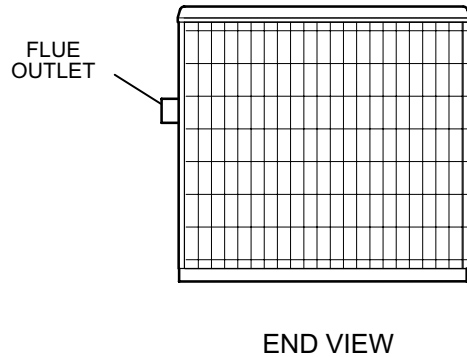
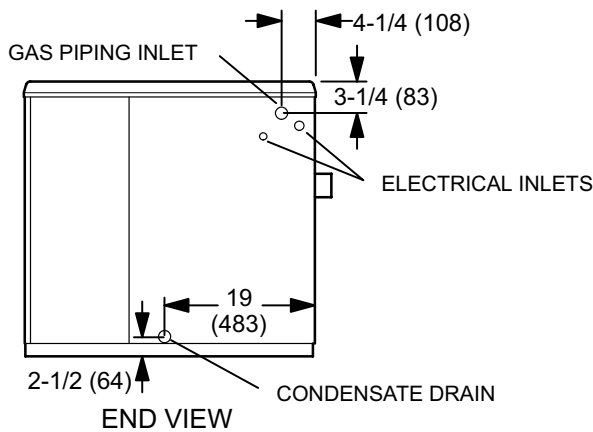
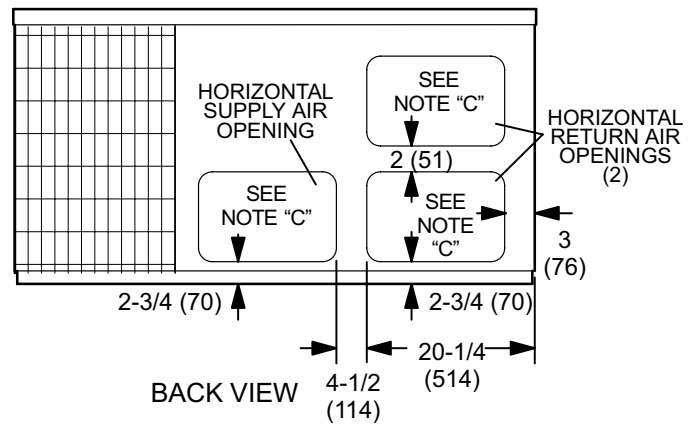
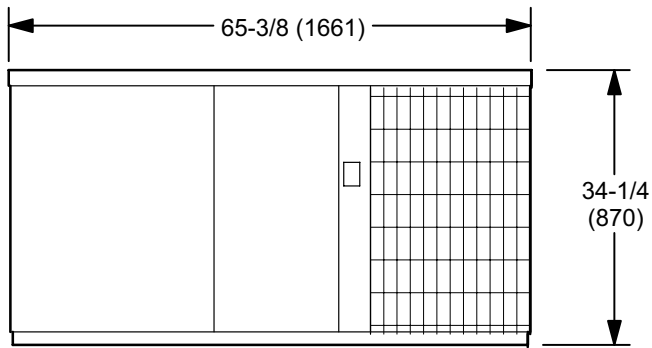

## ACCESSORY DIMENSIONS - INCHES (MM)

### CLIPLOCK 1000 ROOF CURBS

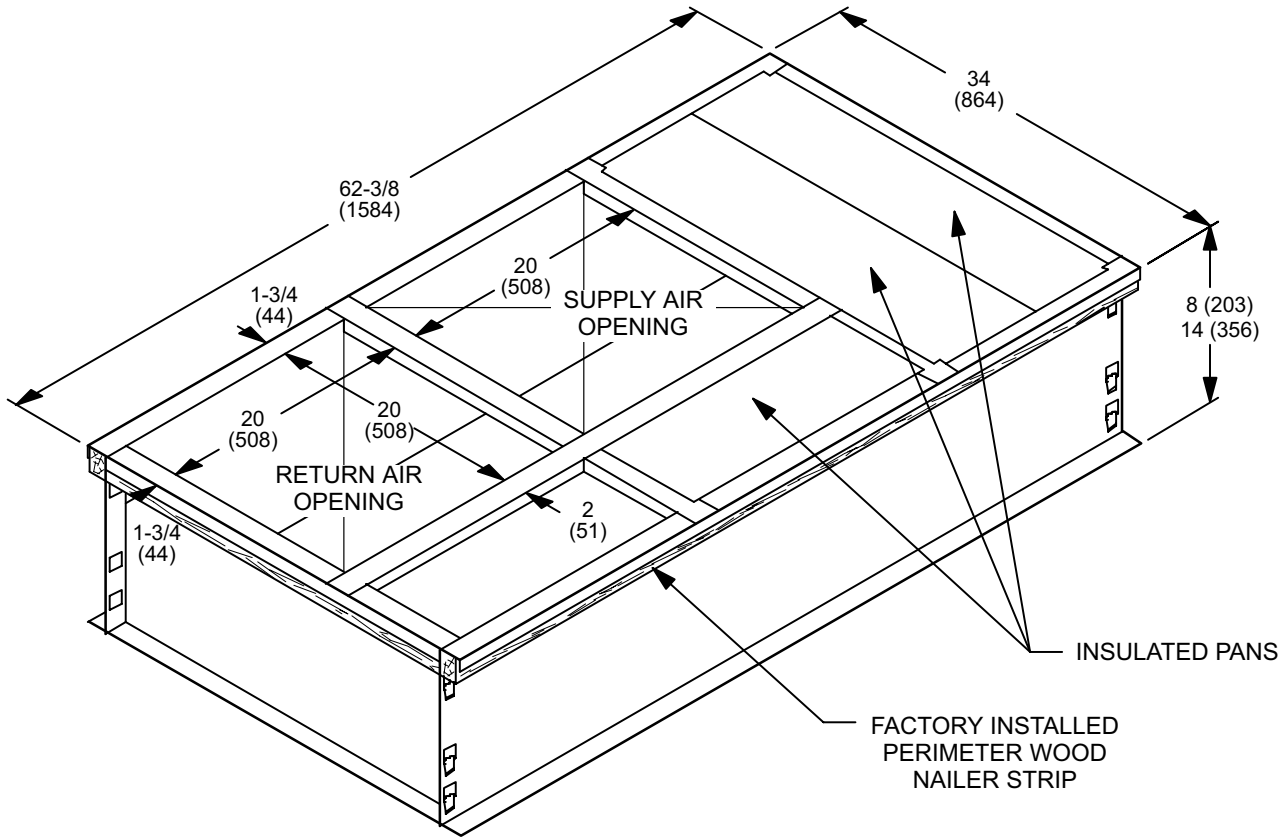

### HINGED ROOF CURBS

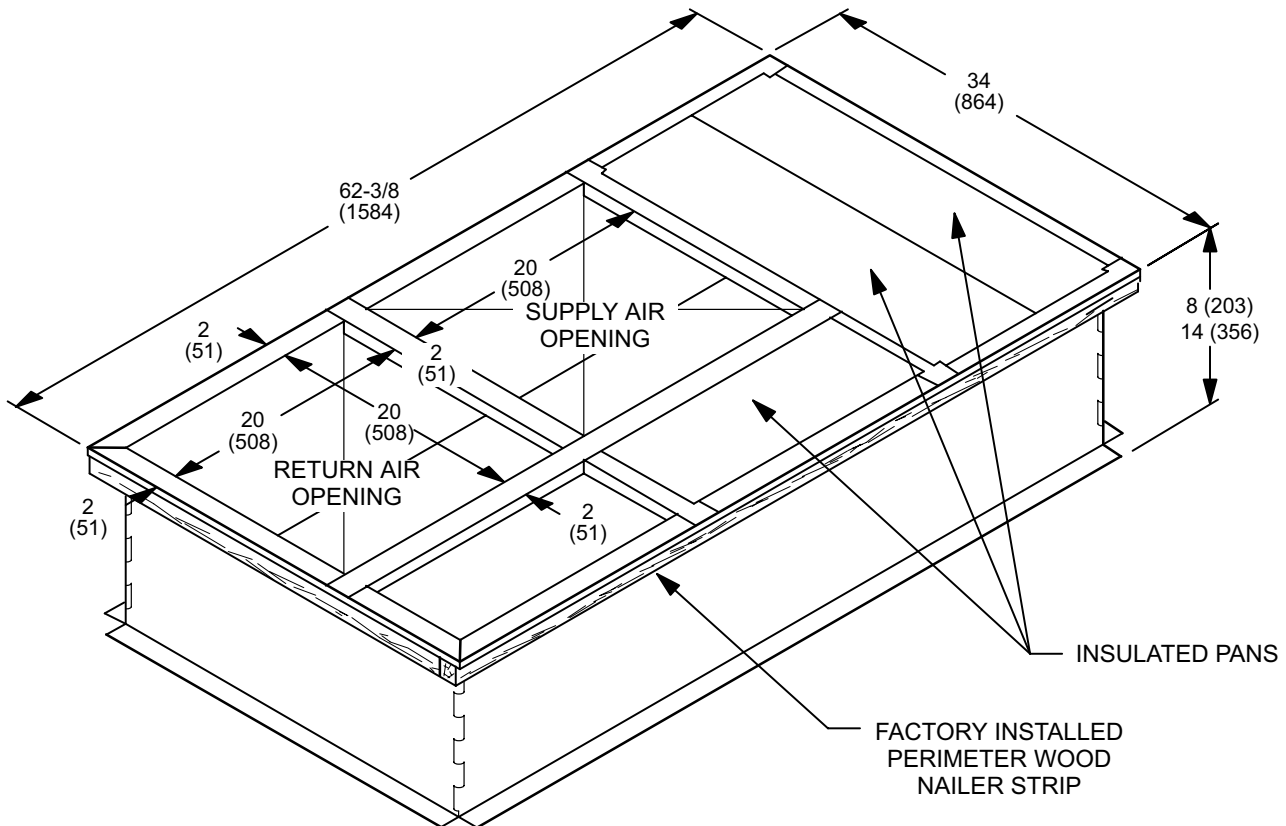

# ACCESSORY DIMENSIONS - INCHES (MM)

## DOWN-FLOW ECONOMIZER DETAILS

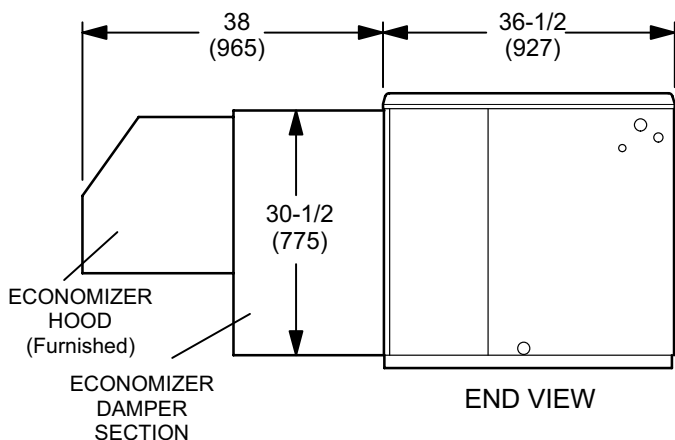

## OUTDOOR AIR DAMPER DETAILS

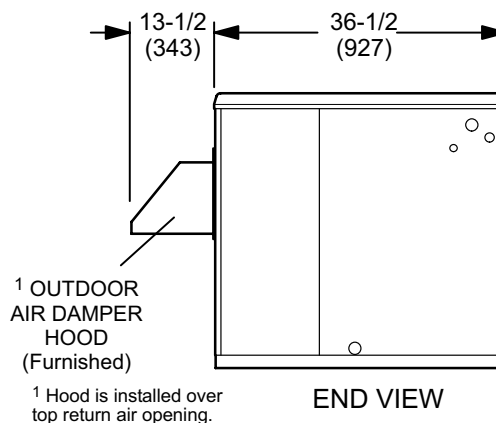

## HORIZONTAL ECONOMIZER DETAILS

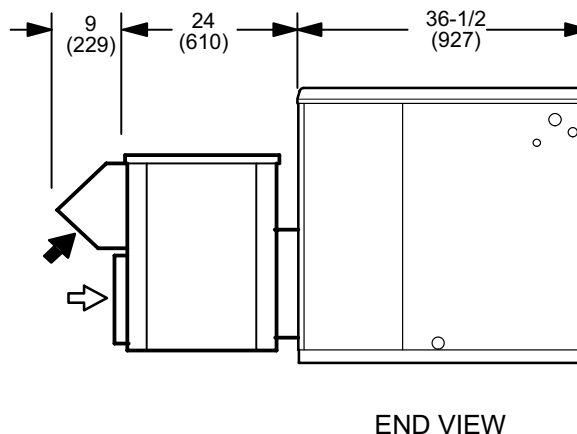
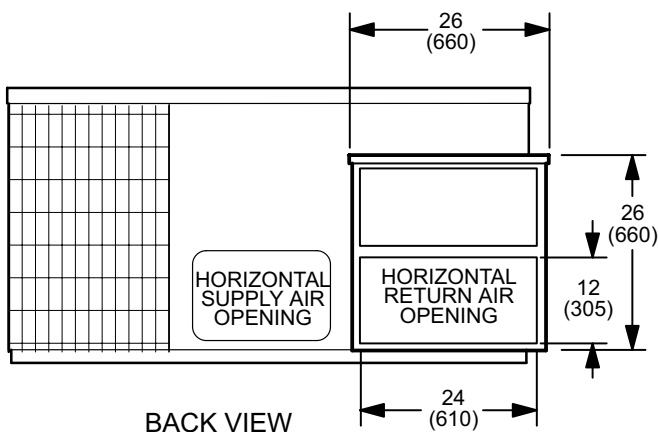
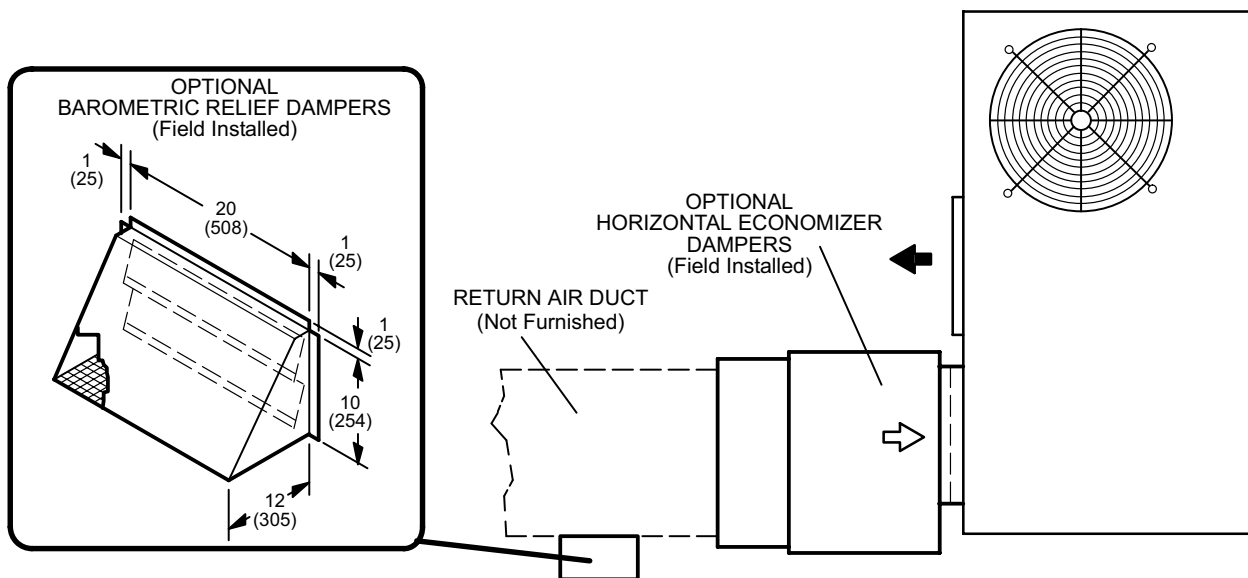



GAS-FIRED



**LISTED**



**ARI Standard  
210/240 UAC**



Visit us at [www.lennox.com](http://www.lennox.com)

For the latest technical information, [www.lennoxravenet.com](http://www.lennoxravenet.com)

Contact us at 1-800-4-LENNOX

NOTE - Due to Lennox' ongoing commitment to quality, Specifications, Ratings and Dimensions subject to change without notice and without incurring liability. Improper installation, adjustment, alteration, service or maintenance can cause property damage or personal injury. Installation and service must be performed by a qualified installer and servicing agency.

©2006 Lennox Industries Inc.