



AFSH10B

Compact Packaged Heat Pump



Features

- 4- and 5-ton models are convertible to downshot
- High external static pressure (up to 0.8" w.c.) allowing flexible installation
- Quiet, efficient Copeland® compliant scroll compressor is safeguarded by internal pressure relief valves and inherent thermal protection
- Crankcase heater (except scrolls) and accumulator are factory installed
- Hinged control panel allows easy access to internal components
- Compressor suction and service valve gauge ports are positioned to provide plenty of access room
- Field-installed plug-in electric heat strips from 5-25 kW offer installation flexibility
- Galvanized steel base rails improve structural integrity for easy lifting
- Square-to-round duct adapters, roof curbs and manual and motorized air dampers are available
- Internal pressure relief valves and inherent thermal protection safeguard against unit failure
- Durable cabinetry sheds water and locks out the weather in every season
- Field-proven 30/60/90 time-temperature defrost control is designed to operate only when needed
- Three-speed direct-drive blower can be easily adjusted for customer comfort
- Naltex® Hail Guard™ protects against fin damage that can reduce efficiency
- All models ETL, ETLC and ARI listed

Efficiency:

10 SEER 7.0 HSPF

Warranty:

5-year limited—compressor
5-year limited—components

Capacity:

2- to 5-ton cooling capacity

AFSH10B Compact Packaged Heat Pump

Unit Specifications

		AFSH10B24P	AFSH10B30P	AFSH10B36P	AFSH10B42P	AFSH10B48P	AFSH10B60P
Condensor Coil	Face Area (ft. ²)	6.71	6.71	6.71	6.71	11.97	11.97
	Tube/Fin Material	Grooved Copper /Aluminum	Grooved Copper /Aluminum	Grooved Copper /Aluminum	Grooved Copper /Aluminum	Grooved Copper /Aluminum	Grooved Copper /Aluminum
	Tube Diameter	3/8"	3/8"	3/8"	3/8"	3/8"	3/8"
	No. of Rows	1	2	2	3	2	2
	Fins per Inch	20	20	20	20	20	20
OD Fan	Diameter (in.)	18"	18"	18"	18"	22"	22"
	No. of Blades	3	4	4	4	3	3
	RPM	1100	1100	1100	1100	1100	1100
Evaporator Coil	Face Area (ft. ²)	2.67	2.67	2.67	2.67	4.67	4.67
	Tube/Fin Material	Grooved Copper /Aluminum	Grooved Copper /Aluminum	Grooved Copper /Aluminum	Grooved Copper /Aluminum	Grooved Copper /Aluminum	Grooved Copper /Aluminum
	Tube Diameter (in.)	3/8"	3/8"	3/8"	3/8"	3/8"	3/8"
	No. of Rows	2	3	3	4	3	3
	Fins per Inch	14	16	16	16	16	16
	Indoor Blower Wheel (DxW)	10" x 8"	10" x 8"	10" x 8"	10" x 8"	10" x 10"	10" x 10"
	Refrigerant Charge, R-22 (oz.)	58	78	80	96	155	162
	Unit Weight (lbs.)	250	285	295	320	415	430
Dimensions	Cabinet Width (A)	39"	39"	39"	39"	47-3/8"	47-3/8"
	Cabinet Depth (B)	39"	39"	39"	39"	47-3/8"	47-3/8"
	Height (C)	31-7/8"	31-7/8"	31-7/8"	31-7/8"	35-7/8"	35-7/8"
	Baseraill Width (D)	40-3/8"	40-3/8"	40-3/8"	40-3/8"	48-3/4"	48-3/4"
	Baseraill Depth (E)	40-3/8"	40-3/8"	40-3/8"	40-3/8"	48-3/4"	48-3/4"
	Return Opening(s) (FxG)	12" x 12"	12" x 12"	12" x 12"	12" x 12"	10-9/16" x 16-1/16"	10-9/16" x 16-1/16"
	Supply Opening(s) (FxH)	12" x 12"	12" x 12"	12" x 12"	12" x 12"	10-9/16" x 16-1/16"	10-9/16" x 16-1/16"
	J	6-3/8"	6-3/8"	6-3/8"	6-3/8"	1"	1"
	K	5-7/8"	5-7/8"	5-7/8"	5-7/8"	5-3/4"	5-3/4"
	L	6-3/4"	6-3/4"	6-3/4"	6-3/4"	8"	8"
Duct Configuration	Dedicated Horizontal	Dedicated Horizontal	Dedicated Horizontal	Dedicated Horizontal	Convertible	Convertible	

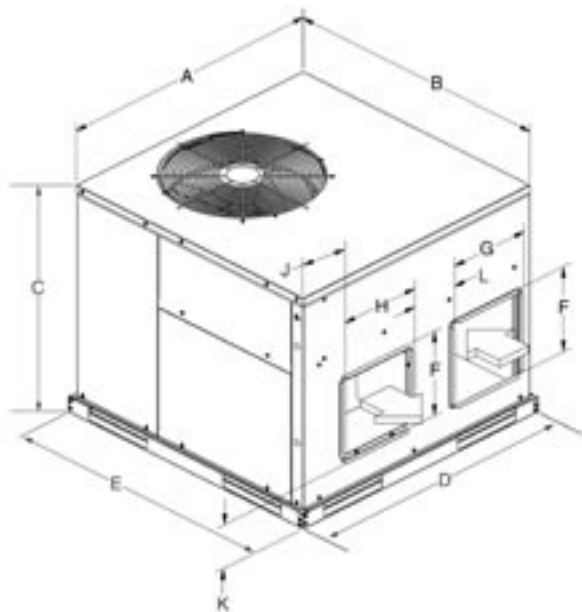

AFSH10B Compact Packaged Heat Pump

Unit Dimensions – Downflow and Side Conversions

	AFSH10B48P/T	AFSH10B60P/T
Cabinet Width (A)	47-3/8"	47-3/8"
Cabinet Depth (B)	47-3/8"	47-3/8"
Height (C)	30-3/4"	30-3/4"
Supply Opening Hor. (D x F)	16 x 10-9/16	16 x 10-9/16
Return Opening Hor. (E x G)	16 x 10-9/16	16 x 10-9/16
Side of Unit to Supply Opening, Hor. (H)	1"	1"
Bottom of Unit to Supply & Return Openings, Hor. (I)	3-5/16"	3-5/16"
Supply to Return Openings, Hor. (J)	8-3/16"	8-3/16"
Supply Opening Downshot (K x N)	10-9/16 x 16"	10-9/16 x 16"
Return Opening Downshot (L x M)	16 x 10-9/16"	16 x 10-9/16"
Side of Unit to Supply Opening Downshot (P)	3-3/4"	3-3/4"
Back Edge to Supply & Return Downshot (R)	3-1/8"	3-1/8"

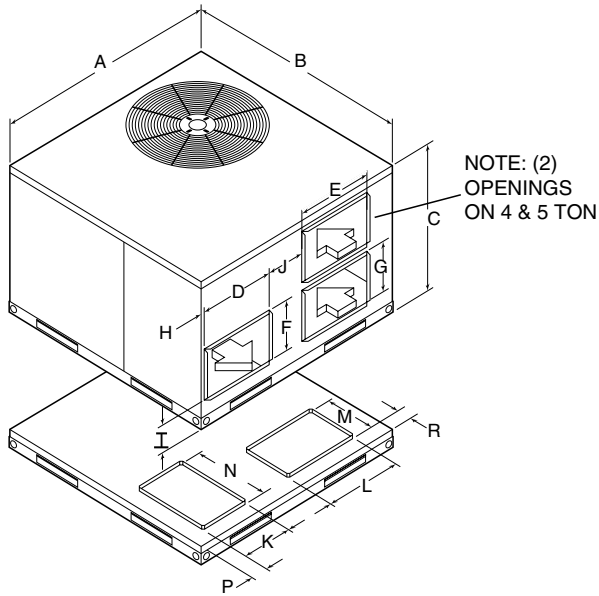

AFSH10B Compact Packaged Heat Pump

Electrical Data

		AFSH10B24P	AFSH10B30P	AFSH10B36P	AFSH10B42P	AFSH10B48P	AFSH10B60P
Unit	Rated Voltage (Vac)	208/230	208/230	208/230	208/230	208/230	208/230
	Phase	1	1	1	1	1	1
	Frequency (Hz.)	60	60	60	60	60	60
	Approved Voltage Range	197-253	197-253	197-253	197-253	197-253	197-253
	Minimum Circuit Amps	17.6	22.0	23.9	27.7	32.8	38.2
Com-pressor	Maximum Fuse ¹	30	35	40	45	50	60
	Rated Load Amps	13.2	16.4	17.9	20.7	24.3	28.6
Outdoor Fan	Locked Rotor Amps	59	84	100	127	131	150
	Full Load Amps	0.8	1.1	1.1	2.0	2.0	2.0
Indoor Blower	Horsepower	1/10	1/5	1/5	1/4	1/4	1/4
	Full Load Amps	2.1	2.1	3.9	3.9	5.0	5.0
	Horsepower	1/3	1/3	1/2	1/2	.09	.09

¹ Electric heat and blower on separate power supply.

Performance Data

		AFSH10B24P	AFSH10B30P	AFSH10B36P	AFSH10B42P	AFSH10B48P	AFSH10B60P
Cooling	Cooling Capacity ^{2, 3}	22,800	28,600	34,200	40,000	45,500	57,000
	SEER ²	10.00	10.00	10.00	10.00	10.00	10.00
	EER at 95°F	8.70	8.80	8.80	8.90	8.70	8.60
	S/T ⁴	0.73	0.72	0.72	0.71	0.72	0.73
	Airflow (SCFM)	850	1,000	1,200	1,400	1,650	1,800
Heating	Heating Capacity ^{2, 5}	23,200	29,000	34,600	40,500	46,000	58,000
	HSPF ²	6.60	6.60	6.60	6.60	6.60	6.80
	COP ⁵	2.92	2.94	2.96	2.92	2.94	2.96

² Rated in accordance with ARI Standard 210/240 certification program, which is based on ARI Standard 210/240.

³ Net capacity based on 95°F outdoor dry bulb, 80°F indoor dry bulb, and 67°F indoor wet bulb at rated airflow.

⁴ Net Sensible capacity divided by net Total capacity at ARI Standard 210/240 Test A.

⁵ Net Capacity & Performance based on 47°F outdoor dry bulb, 43°F outdoor wet bulb, and 70°F indoor dry bulb at rated airflow.

AFSH10B Compact Packaged Heat Pump

Airflow Data

External Static Pressure (in w.c.)	AFSH10B24P			AFSH10B30P			AFSH10B36P		
	Low	Medium	High	Low	Medium	High	Low	Medium	High
0.1	800	1100	1260	800	1100	1260	1380	1560	1830
0.2	790	1080	1240	790	1080	1240	1360	1540	1440
0.3	760	1060	1220	760	1060	1220	1350	1490	1660
0.4	740	1050	1190	740	1050	1190	1310	1430	1580
0.5	720	1030	1150	720	1030	1150	1270	1370	1500
0.6	700	980	1110	700	980	1110	1210	1310	1410
0.7	610	930	1060	610	930	1060	1140	1230	1310
0.8	530	880	980	530	880	980	1080	1150	1220

External Static Pressure (in w.c.)	AFSH10B42P			AFSH10B48P			AFSH10B60P		
	Low	Medium	High	Low	Medium	High	Low	Medium	High
0.1	1380	1560	1830	1990	2080	2160	1990	2080	2160
0.2	1360	1540	1440	1920	2000	2070	1920	2000	2070
0.3	1350	1490	1660	1850	1940	1980	1850	1940	1980
0.4	1310	1430	1580	1770	1840	1900	1770	1840	1900
0.5	1270	1370	1500	1670	1760	1810	1670	1760	1810
0.6	1210	1310	1410	1580	1650	1700	1580	1650	1700
0.7	1140	1230	1310	1470	1540	1590	1470	1540	1590
0.8	1080	1150	1220	1370	1440	1490	1370	1440	1490

Accessories

	AFSH10B24P	AFSH10B30P	AFSH10B36P	AFSH10B42P	AFSH10B48P	AFSH10B60P
High Pressure Switch	20442501	20442501	20442501	20442501	20442501	20442501
Low Pressure Switch	Factory-Installed	Factory-Installed	Factory-Installed	Factory-Installed	Factory-Installed	Factory-Installed
Short Cycle Protection	Factory-Installed	Factory-Installed	Factory-Installed	Factory-Installed	Factory-Installed	Factory-Installed
Hard Start Kit	20442707	20442707	20442707	20442707	20442707	20442706
Crank Case Heater Kit	20442803	20442803	20442803	20442803	20442803	20442802
Sound Blanket	20442903	20442903	20442904	20442904	20442904	20442902
Roof Curb	Not Applicable	Not Applicable	Not Applicable	Not Applicable	20490001	20490001
Manual Outside Air Damper	Not Applicable	Not Applicable	Not Applicable	Not Applicable	20490101	20490101
Motorized Outside Air Damper	Not Applicable	Not Applicable	Not Applicable	Not Applicable	20490201	20490201
Economizer	Not Applicable	Not Applicable	Not Applicable	Not Applicable	20490301	20490301
Round Duct Adapter	Not Applicable	Not Applicable	Not Applicable	Not Applicable	20490401	20490401

Accessory Heat Kits						
BHC05P	20491304	20491304	20491304	20491304	20491304	20491304
BHP05P	20491301	20491301	20491301	20491301	20491301	20491301
BHC07P	20491305	20491305	20491305	20491305	20491305	20491305
BHP07P	20491302	20491302	20491302	20491302	20491302	20491302
BHC10P	20491306	20491306	20491306	20491306	20491306	20491306
BHP10P	20491303	20491303	20491303	20491303	20491303	20491303
BHC15P	20491307	20491307	20491307	20491307	20491307	20491307
BHC20P	20491308	20491308	20491308	20491308	20491308	20491308
No Heat Kit ¹	20491401	20491401	20491401	20491401	20491401	20491401

¹ No Heat Kit required for operation if electric heat is not installed.

BHC = Accessory heat kit with circuit breaker.

BHP = Accessory heat kit with pigtail only (no breaker).

AFSH10B Compact Packaged Heat Pump

Accessory Heat Kits Electrical Rating Information

					AFSH10B24P	AFSH10B30P	AFSH10B36P	AFSH10B42P	AFSH10B48P	AFSH10B60P
BHP05P BHC05P	Circuit #1	208V	MCA ¹	3.6 kw	24.3	24.3	25.9	25.9	27.9	27.9
			MOP ²		25	25	30	30	30	30
		240V	MCA ¹	4.8 kw	27.6	27.6	29.3	29.3	31.3	31.3
			MOP ²		30	30	30	30	35	35
BHP07P BHC07P	Circuit #1	208V	MCA ¹	5.4 kw	35.1	35.1	36.8	36.8	38.8	38.8
			MOP ²		40	40	40	40	40	40
		240V	MCA ¹	7.2 kw	40.1	40.1	41.8	41.8	43.8	43.8
			MOP ²		45	45	45	45	45	45
BHP10P BHC10P	Circuit #1	208V	MCA ¹	7.2 kw	46	46	47.6	47.6	49.6	49.6
			MOP ²		50	50	50	50	50	50
		240V	MCA ¹	9.6 kw	52.6	52.6	54.3	54.3	56.3	56.3
			MOP ²		60	60	60	60	60	60
BHP15P BHC15P	Circuit #1	208V	MCA ¹	7.2 kw	46	46	47.6	47.6	49.6	49.6
			MOP ²		50	50	50	50	50	50
		240V	MCA ¹	9.6 kw	52.6	52.6	54.3	54.3	56.3	56.3
			MOP ²		60	60	60	60	60	60
	Circuit #2	208V	MCA ¹	3.6 kw	21.7	21.7	21.7	21.7	21.7	21.7
			MOP ²		25	25	25	25	25	25
		208V	MCA ¹	4.8 kw	25	25	25	25	25	25
			MOP ²		25	25	25	25	25	25
	Single Point Power Supply	208V	MCA ¹	10.8 kw	67.6	67.6	69.3	69.3	71.3	71.3
			MOP ²		70	70	70	70	80	80
240V		MCA ¹	14.4 kw	77.6	77.6	79.3	79.3	81.3	81.3	
		MOP ²		80	80	80	80	90	90	
BHP20P BHC20P	Circuit #1	208V	MCA ¹	7.2 kw	—	—	47.6	47.6	49.6	49.6
			MOP ²		—	—	50	50	50	50
		240V	MCA ¹	9.6 kw	—	—	47.6	47.6	47.6	47.6
			MOP ²		—	—	47.6	47.6	47.6	47.6
	Circuit #2	208V	MCA ¹	7.2 kw	—	—	43.3	43.3	43.3	43.3
			MOP ²		—	—	45	45	45	45
		240V	MCA ¹	9.6 kw	—	—	54.3	54.3	56.3	56.3
			MOP ²		—	—	60	60	60	60
	Circuit #3	208V	MCA ¹	7.2 kw	—	—	—	—	21.7	21.7
			MOP ²		—	—	—	—	25	25
		240V	MCA ¹	9.6 kw	—	—	—	—	25	25
			MOP ²		—	—	—	—	25	25
	Single Point Power Supply	208V	MCA ¹	14.4 kw	—	—	104.3	104.3	106.3	106.3
			MOP ²		—	—	110	110	110	110
240V		MCA ¹	19.2 kw	—	—	104.3	104.3	106.3	106.3	
		MOP ²		—	—	110	110	110	110	

1 MCA = Minimum circuit capacity. Wire must be sized properly per NEC or CEC.
 2 MOP = Maximum Overcurrent Protection.

AFSH10B Compact Packaged Heat Pump

Accessory Heat Kits Electrical Rating Information (continued)

					AFSH10B24P	AFSH10B30P	AFSH10B36P	AFSH10B42P	AFSH10B48P	AFSH10B60P
BHP25P BHC25P	Circuit #1	208V	MCA ¹	7.2 kw	—	—	—	—	49.6	49.6
			MOP ²		—	—	—	—	50	50
	240V	MCA ¹	9.6 kw	—	—	—	—	56.3	56.3	
		MOP ²		—	—	—	—	60	60	
	Circuit #2	208V	MCA ¹	7.2 kw	—	—	—	—	43.3	43.3
			MOP ²		—	—	—	—	45	45
	240V	MCA ¹	9.6 kw	—	—	—	—	50	50.0	
		MOP ²		—	—	—	—	50	50	
	Circuit #3	208V	MCA ¹	xx kw	—	—	—	—	21.7	21.7
			MOP ²		—	—	—	—	25	25
		240V	MCA ¹	xx kw	—	—	—	—	25	25
			MOP ²		—	—	—	—	25	25
Single Point Power Supply	208V	MCA ¹	14.4 kw	—	—	—	—	114.6	114.6	
		MOP ²		—	—	—	—	120	120	
	240V	MCA ¹	19.2 kw	—	—	—	—	131.3	131.3	
		MOP ²		—	—	—	—	140	140	

1 MCA = Minimum circuit capacity. Wire must be sized properly per NEC or CEC.

2 MOP = Maximum Overcurrent Protection.



2100 Lake Park Boulevard
Richardson, TX 75080
1.800.982.2333

www.aireflo-hvac.com



All models 208-230 volt/1-phase/60 Hz. 36/48/60 models also available in 208-230 volt/
3-phase/60 Hz. Certified in accordance with the ARI standard 210/240 certification program,
which is based on ARI standard 210/240.

68M08 (9/04)

© Copyright Lennox Industries, Inc., 2004

PC39303