



VERIFIED
ENERGY
PERFORMANCE

CERTIFICATION APPLIES ONLY
WHEN THE COMPLETE
SYSTEM IS LISTED
WITH ARI



COA Condensing Units

SEER - 10.00

1.5 thru 5 Tons (5.3 to 17.6 kW)

Cooling Capacity - 18,000 to 56,500 Btuh (5.3 to 16.6 kW)

June 1999

No. 210256

ENGINEERING SPECIFICATIONS

MODEL NUMBER IDENTIFICATION

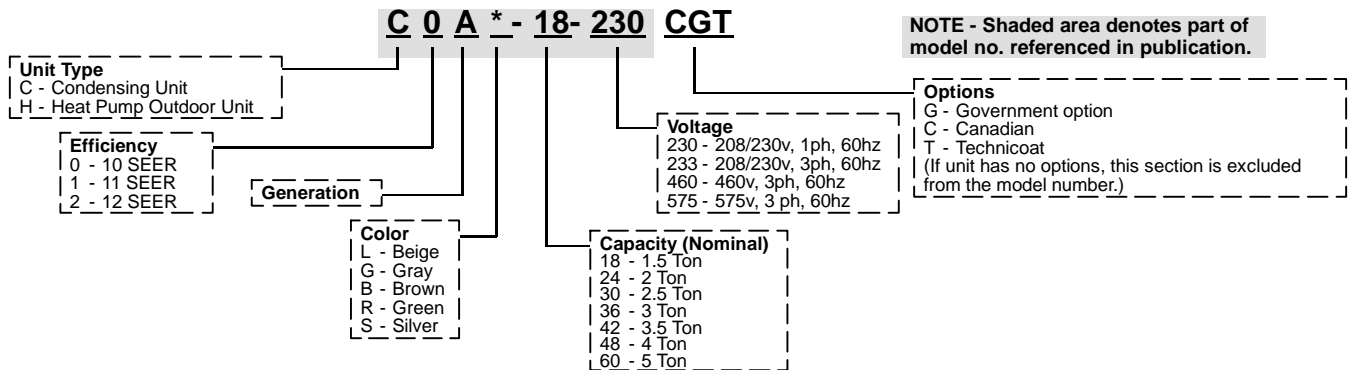

FEATURES

Applications

- 10.00 SEER.
- 1.5 through 5 ton (5.3 through 17.6 kW) matches with refrigerant metering orifice or TXV.
- Single phase power supply.
- Vertical air discharge allows concealment behind shrubs at grade level or out of sight on a roof.
- Matching add-on furnace evaporator units provide wide range of cooling capacities and applications. See ARI Ratings table.
- Units shipped completely factory assembled, piped and wired. Each unit is test operated at the factory insuring proper operation.
- Installer must set condensing unit, connect refrigerant lines and make electrical connections to complete job.

Approvals

- Rated in accordance with ARI Standard 210/240-94.
- Sound rated in accordance with test conditions included in ARI Standard 270-95.
- Tested and rated according to U.S. Department of Energy (DOE) requirements.
- Condensing units and components within bonded grounding to meet safety standards for servicing required by UL, NEC and CEC.
- Units are UL and ULC listed.
- Energy rating verified by CSA.
- Developed in accordance with ISO 9000 quality standards.

Equipment Warranty

- Compressor — Five years.
- All other covered components — One year.
- Refer to Limited Warranty Certificate included with unit for specific details.

Copeland® Compliant Scroll Compressor (-42, -48, -60 Models)

- Compressor features high efficiency with uniform suction flow, constant discharge flow and high volumetric efficiency and quiet operation.
- Compressor consists of two involute spiral scrolls matched together to generate a series of crescent shaped gas pockets between them.
- During compression, one scroll remains stationary while the other scroll orbits around it.
- Gas is drawn into the outer pocket, the pocket is sealed as the scroll rotates.
- As the spiral movement continues, gas pockets are pushed to the center of the scrolls. Volume between the pockets is reduced.
- When pocket reaches the center, gas is now at high pressure and is forced out of a port located in the center of the fixed scrolls.
- During compression, several pockets are compressed simultaneously resulting in a smooth continuous compression cycle.
- Continuous flank contact, maintained by centrifugal force, minimizes gas leakage and maximizes efficiency.
- Scroll compressor is tolerant to the effects of slugging and contaminants. If this occurs, scrolls separate, allowing liquid or contaminants to be worked toward the center and discharged.
- Low gas pulses during compression reduces operational sound levels.
- Compressor motor is internally protected from excessive current and temperature.
- Compressor is installed in the unit on resilient rubber mounts for vibration free operation.

Reciprocating Compressor (-18 thru -36 Models)

- Designed for dependable efficiency with minimum operating cost.
- Suction cooled and overload protected with internal pressure relief.
- Hermetically sealed with built-in protection from excessive current and temperatures.
- Running gear assembly resiliently suspended internally inside case. Compressor installed in unit on resilient rubber mounts assuring low sound and vibration free operation.

FEATURES (Continued)

2

Refrigerant Flow Control Choice

- Applicable to refrigerant metering orifice or expansion valve systems.

Refrigerant Metering Orifice

- Accurately meters refrigerant in system.
- Refrigerant control is accomplished by exact sizing of orifice.
- Orifice equalizes pressure shortly after compressor stops, unit starts unloaded, eliminating need for additional controls.

Copper Tube/Enhanced Fin Coil

- Copper tube construction.
- Ripple-edged aluminum fins.
- Lanced fins provide maximum exposure of fin surface to air stream resulting in excellent heat transfer.
- Fin collars grip tubing for maximum contact area.
- Flared shoulder tubing connections/silver soldering construction.
- Coil is factory tested under high pressure to insure leakproof construction.
- Entire coil is accessible for cleaning.
- Polyvinyl Chloride (PVC) coated steel wire coil guard furnished as standard.

Unit Cabinet

- Heavy gauge steel cabinet.
- Baked-on outdoor enamel paint finish provides superior rust and corrosion protection.
- Painted base section.
- Control box is conveniently located with all controls factory wired.
- Drainage holes are provided in base section for moisture removal.

Condenser Fan

- Direct drive fan moves large air volumes uniformly through entire condenser coil for high refrigerant cooling capacity.
- Vertical air discharge minimizes operating sounds and eliminates damage to lawn and shrubs.
- Fan motor has sleeve bearings and is inherently protected.
- Motor totally enclosed for maximum protection from weather, dust and corrosion.
- Rain shield on motor provides additional protection from moisture.
- Louvered steel top fan guard furnished as standard.
- Fan service access accomplished by removal of top panel.

Refrigerant Line Connections, Electrical Inlets, Service Valves

- Sweat connection suction and liquid lines are located on corner of unit cabinet.
- Fully serviceable brass service valves prevent corrosion and provide access to refrigerant system. Suction valve can be fully shut off, while liquid valve may be front seated to manage refrigerant charge while servicing system.
- Refrigerant line connections and field wiring inlets are located in one central area of cabinet for easy access. See dimension drawing.

OPTIONAL ACCESSORIES

Compressor Crankcase Heater

- Crankcase heater prevents migration of liquid refrigerant into compressor and ensures proper compressor lubrication.
- -18 thru -36 models order 68887.
- -42 thru -60 models order 90P12.

Compressor Monitor (45F08) - Optional for Canada Only

- Non-adjustable switch (low ambient cut-out) prevents compressor operation when outdoor temperature is below 35°F (2°C).

Compressor Sound Cover

- Compressor sound cover can be field installed to reduce operating sound levels.
- See Specifications tables for catalog number.

Expansion Valve Kits (Optional For Expansion Valve Systems)

- Must be ordered extra and field installed on certain evaporator units. See ARI Ratings table.

Hail Guards

- Constructed of louvered heavy gauge steel painted to match cabinet.
- Surrounds unit on all four sides to prevent damage to the coil.
- See Specifications tables for catalog number.

Low Ambient Kit (24H77) - Optional For Expansion Valve Systems Only

- Condensing units operate satisfactorily down to 45°F (7°C) outdoor air temperature without any additional controls.
- Low Ambient Control Kit can be field installed, allowing unit operation down to 30°F (-1°C).

Mounting Base (69J06)

- MB2-S high density polyethylene mounting base is lightweight, sturdy, sound absorbing and will withstand the effects of sun, heat, cold, moisture, oil and refrigerant.
- Provides permanent foundation for condensing units.
- 22-1/4 x 22-1/4 x 3 in. (565 x 565 x 76 mm).

Refrigerant Line Kits

- Refrigerant lines (suction & liquid) are shipped refrigeration clean. Lines are cleaned, dried, pressurized and sealed at factory.
- Suction line fully insulated.
- L15 lines are stubbed at both ends.
- See Refrigerant Line Kit table for selection.
- Kit is not available for C0A*-60 model and must be field fabricated.

Thermostat

- Thermostat is not furnished with unit.

Timed-Off Control (47J27)

- Prevents compressor short-cycling.
- Allows suction and discharge pressures to equalize.
- Permits compressor start-up in an unloaded condition.
- Automatic reset with 5 minute delay between compressor cycles.

Unit Stand-Off Kit (94J45)

- Black high density polyethylene feet are available to raise unit off of mounting surface away from damaging moisture.
- Four feet are furnished per order number.

SPECIFICATIONS

Model No.		C0A*-18-230	C0A*-24-230	C0A*-30-230	C0A*-36-230
Nominal Tonnage (kW)		1.5 (5.3)	2 (7.0)	2.5 (8.8)	3 (10.6)
Liquid line - o.d. connection (sweat) - in. (mm)		3/8 (9.5)	3/8 (9.5)	3/8 (9.5)	3/8 (9.5)
Suction line - o.d. connection (sweat) - in. (mm)		5/8 (15.9)	5/8 (15.9)	3/4 (19.1)	3/4 (19.1)
☐ Refrigerant charge furnished (HCFC-22)		lbs.	4 lbs. 0 oz.	4 lbs. 9 oz.	5 lbs. 0 oz.
		kg	1.81 kg	2.07 kg	2.27 kg
Condenser Coil	Net face area - sq. ft. (m ²)	10.46 (0.97)	10.46 (0.97)	10.46 (0.97)	11.41 (1.06)
	Tube diameter - in. (mm)	5/16 (7.9)	5/16 (7.9)	5/16 (7.9)	5/16 (7.9)
	No. of rows	1	1	1	1
	Fins per inch (m)	18 (709)	18 (709)	18 (709)	22 (866)
Condenser Fan	Diameter - in. (mm)	18 (457)	18 (457)	18 (457)	18 (457)
	No. of blades	3	3	3	3
	Motor hp (W)	1/6 (124)	1/6 (124)	1/6 (124)	1/4 (187)
	Cfm (L/s)	2170 (1025)	2170 (1025)	2170 (1025)	2510 (1185)
	Rpm	1100	1100	1100	1103
	Watts	254	254	254	266
Shipping weight - lbs. (kg) 1 package		136 (62)	136 (62)	136 (62)	140 (64)

OPTIONAL ACCESSORIES - Must Be Ordered Extra

Compressor Crankcase Heater	68887	68887	68887	68887
Compressor Monitor (Optional for Canada Only)	45F08	45F08	45F08	45F08
Compressor Sound Cover	69J17	69J17	69J17	53J39
Hail Guards	17L71	17L71	17L71	17L73
Low Ambient Kit - for use with expansion valve systems only	24H77	24H77	24H77	24H77
Mounting Base	69J06	69J06	69J06	69J06
Timed-Off Control	47J27	47J27	47J27	47J27
Unit Stand Off Kit	94J45	94J45	94J45	94J45

*Variable field

☐ Refrigerant charge sufficient for 20 ft. (6.0 m) length of refrigerant lines.

SPECIFICATIONS

Model No.		C0A*-42-230	C0A*-48-230	C0A*-60-230
Nominal Tonnage (kW)		3.5 (12.3)	4 (14.1)	5 (17.6)
Liquid line - o.d. connection (sweat) - in. (mm)		3/8 (9.5)	3/8 (9.5)	3/8 (9.5)
Suction line - o.d. connection (sweat) - in. (mm)		7/8 (22.2)	7/8 (22.2)	1-1/8 (28.6)
☐ Refrigerant charge furnished (HCFC-22)		lbs.	5 lbs. 12 oz.	7 lbs. 4 oz.
		kg	2.61 kg	3.29 kg
Condenser Coil	Net face area - sq. ft. (m ²)	Outer coil	13.31 (1.24)	15.11 (1.40)
		Inner coil	----	5.4 (0.50)
	Tube diameter - in. (mm)	5/16 (7.9)	5/16 (7.9)	5/16 (7.9)
	No. of rows	1	1	1
Condenser Fan	Fins per inch (m)	22 (866)	22 (866)	22 (866)
	Diameter - in. (mm)	18 (457)	18 (457)	22 (559)
	No. of blades	4	4	4
	Motor hp (W)	1/3 (249)	1/3 (249)	1/3 (249)
	Cfm (L/s)	2800 (1320)	2950 (1390)	3900 (1840)
	Rpm	1116	1100	1100
Shipping weight - lbs. (kg) 1 package		138 (63)	196 (890)	199 (90)

OPTIONAL ACCESSORIES - Must Be Ordered Extra

Compressor Crankcase Heater	90P12	90P12	90P12
Compressor Monitor (Optional for Canada Only)	45F08	45F08	45F08
Compressor Sound Cover	69J03	69J03	69J03
Hail Guards	17L73	17L73	17L73
Low Ambient Kit - for use with expansion valve systems only	24H77	24H77	24H77
Mounting Base	69J06	69J06	69J06
Timed-Off Control	47J27	47J27	47J27
Unit Stand Off Kit	94J45	94J45	94J45

*Variable field

☐ Refrigerant charge sufficient for 20 ft. (6.0 m) length of refrigerant lines.

Model No. ② Sound No.	① ARI Standard 210/240 Ratings				Total Unit Watts	Up-Flow	Horizontal	Down-Flow	③ Expansion Device Required	
	SEER	EER	Cooling Cap.							Evaporator Coils
			Btuh	kW						
C0A*-18-230 (78 db) ⑤ (76 db)	10.00	9.00	18,000	5.3	2000	④ HA03224C170B252055	---	---	Orifice -0.055 (42J39)	
C0A*-24-230 (78 db) ⑤ (76 db)	10.00	9.30	23,600	6.9	2540	④ HA05230C170B252061	---	---	Orifice -0.061 (42J42)	
C0A*-30-230 (78 db) ⑤ (76 db)	10.00	9.00	29,000	8.5	3220	HA15242C170B252000	---	---	TXV - 26K49	
	10.00	9.00	29,000	8.5	3220	④ HA15248C205B252067	---	---	Orifice -0.067 (42J45)	
C0A*-36-230 (80 db) ⑤ (78 db)	10.00	8.80	34,000	10.0	3865	④ HA13236C170B252076	---	---	Orifice -0.076 (44L84)	
C0A*-42-230 (78 db) ⑤ (76 db)	10.00	9.0	39,500	11.6	4390	HA13242C170B252080	---	---	Orifice -0.080 (42J52)	
	10.00	9.0	39,500	11.6	4390	④ HA15242C205B252080	---	---	Orifice -0.080 (42J52)	
C0A*-48-230 (80 db) ⑤ (78 db)	10.00	9.30	46,500	13.6	5000	④ HA79248E215B292083	---	---	Orifice -0.083 (44L82)	
	10.00	9.40	46,500	13.6	4995	HA91260E257B292093	---	---	Orifice -0.093 (44L83)	
C0A*-60-230 (80 db) ⑤ (78 db)	10.00	9.20	56,500	16.6	6140	④ HA79248E215B292093	---	---	Orifice -0.083 (44L82)	
	10.00	9.10	56,500	16.6	6210	HA91260E257B292093	---	---	Orifice -0.093 (44L83)	

① Rated in accordance with ARI Standard 210/240; 95°F (35°C) outdoor air temperature, 80°F (27°C) db / 67°F (19°C) wb entering evaporator air with 25 ft. (7.6 m) of connecting refrigerant lines.
 ② Sound Rating Number rated in accordance with test conditions included in ARI Standard 270.
 ③ Expansion valve kit is required and must be ordered extra.
 ④ Most popular evaporator coil match.
 ⑤ Sound Rating with Optional Compressor Sound Cover.

ELECTRICAL DATA

Model No.	C0A*-18-230	C0A*-24-230	C0A*-30-230	C0A*-36-230	C0A*-42-230	C0A*-48-230	C0A*-60-230
Line voltage data - 60 hz - 1 phase	208/230v	208/230v	208/230v	208/230v	208/230v	208/230v	208/230v
Rec. max. fuse/circuit breaker size (amps)	15	20	25	35	40	50	50
① Minimum circuit ampacity	11.1	13.1	16.6	20.4	24.3	29.2	33.2
Compressor	Rated load amps	7.95	10.1	12.4	14.9	17.9	25
	Locked rotor amps	48.3	60	69.4	96	103	170
	Power factor	.97	.96	.92	.89	.84	.80
Condenser Coil Fan Motor	Full load amps	1.1	1.1	1.1	1.7	1.9	1.9
	Locked rotor amps	1.9	1.9	1.9	3.1	4.1	4.1

*Variable Field.
 ① Refer to National or Canadian Electrical Code manual to determine wire, fuse and disconnect size requirements.
 NOTE — Extremes of operating range are plus 10% and minus 5% of line voltage.
 ④ Most popular evaporator coil match.

FIELD WIRING

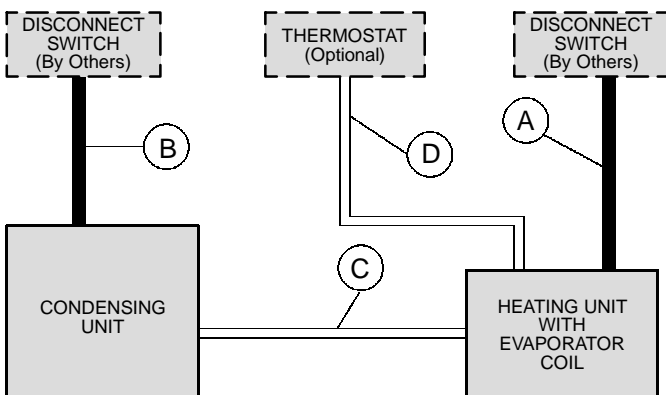

- A — Two or Three Wire Power
- B — Two Wire Power — See Electrical Data
- C — Two Wire Low Voltage — 18 ga. minimum
- D — Four Wire Low Voltage (Electro-Mechanical) 18 ga. minimum
- Five Wire Low Voltage (Electronic) 18 ga. minimum

NOTE — Field Wiring Not Furnished

All wiring must conform to NEC or CEC and local electrical codes.

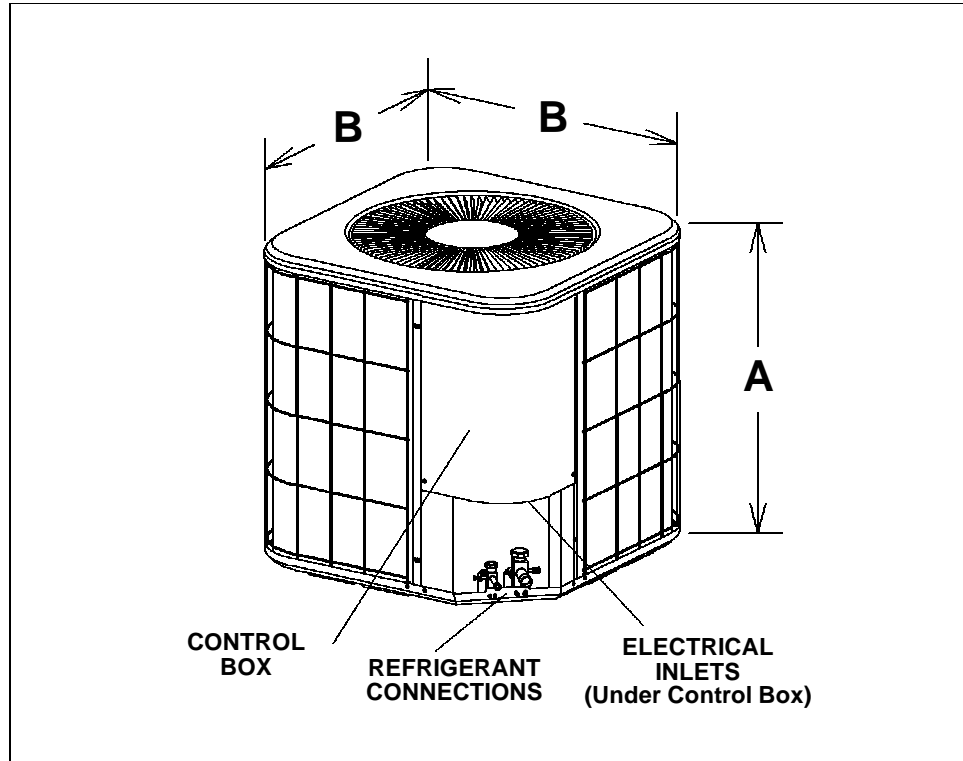

Model No.	A		B	
	in.	mm	in.	mm
C0A*-24-230	33-1/4	845	24-1/4	616
C0A*-30-230	33-1/4	845	24-1/4	616
C0A*-36-230	33-1/4	845	24-1/4	616
C0A*-42-230	33-1/4	845	24-1/4	616
C0A*-48-230	37-1/4	946	28-1/4	718
C0A*-60-230	37-1/4	946	28-1/4	718

REFRIGERANT LINE KITS

Model No.	Line Set Model No.	Length of Lines		Liquid Line Outside Dia.		Suction Line Outside Dia.	
		ft.	m	in.	mm	in.	mm
C0A*-18-230 C0A*-24-230	L15-21-20	20	6	5/16	7.9	5/8	15.9
	L15-21-25	25	8				
	L15-21-35	35	11				
	L15-21-50	50	15				
C0A*-30-230 C0A*-36-230	L15-41-20	20	6	3/8	9.5	3/4	19
	L15-41-30	30	9				
	L15-41-40	40	12				
	L15-41-50	50	15				
C0A*-42-230 C0A*-48-230	L15-65-30	30	9	3/8	9.5	7/8	22.2
	L15-65-40	40	12				
	L15-65-50	50	15				
C0A*-60-230	Field Fabricate			3/8	9.5	1-1/8	28.5

INSTALLATION CLEARANCES - Inches (mm)

One of the two sides nearest the line connections must be 36 inches (914 mm) for service.

Two of the remaining three sides of the unit may be 12 inches (305 mm). The one remaining side must be 36 inches (914 mm).

48 inch (1219 mm) clearance required on top of unit.

COA*-60-230 — HA91260E257B292093 COOLING CAPACITY

Entering Wet Bulb Temperature	Total Air Volume		Outdoor Air Temperature Entering Outdoor Coil																							
			85°F (29°C)						95°F (35°C)						105°F (41°C)						115°F (46°C)					
	Total Cooling Capacity		Comp Motor kW Input	Sensible To Total Ratio (S/T)			Total Cooling Capacity		Comp Motor kW Input	Sensible To Total Ratio (S/T)			Total Cooling Capacity		Comp Motor kW Input	Sensible To Total Ratio (S/T)			Total Cooling Capacity		Comp Motor kW Input	Sensible To Total Ratio (S/T)				
				Dry Bulb						Dry Bulb						Dry Bulb						Dry Bulb				
	cfm	L/s	kBtuh	kW	75°F 24°C	80°F 27°C	85°F 29°C	kBtuh	kW	Input	75°F 24°C	80°F 27°C	85°F 29°C	kBtuh	kW	Input	75°F 24°C	80°F 27°C	85°F 29°C	kBtuh	kW	Input	75°F 24°C	80°F 27°C	85°F 29°C	
63°F (17°C)	1550	730	56.1	16.4	4.52	.71	.84	.96	54.1	15.9	5.01	.72	.85	.97	52.0	15.2	5.58	.73	.87	.99	50.0	14.7	6.27	.74	.89	1.00
	1750	825	57.3	16.8	4.56	.73	.87	.99	55.2	16.2	5.05	.75	.89	1.00	53.1	15.6	5.63	.76	.91	1.00	51.0	14.9	6.32	.77	.93	1.00
	1950	920	58.3	17.1	4.59	.76	.91	1.00	56.2	16.5	5.09	.77	.93	1.00	54.0	15.8	5.67	.79	.94	1.00	52.0	15.2	6.36	.80	.96	1.00
67°F (19°C)	1550	730	59.6	17.5	4.64	.56	.68	.81	57.5	16.9	5.14	.56	.69	.82	55.3	16.2	5.72	.57	.71	.84	53.1	15.6	6.42	.58	.72	.85
	1750	825	60.7	17.8	4.68	.57	.71	.84	58.5	17.1	5.18	.58	.72	.86	56.2	16.5	5.77	.59	.74	.88	54.0	15.8	6.46	.60	.75	.90
	1950	920	61.7	18.1	4.71	.59	.74	.88	59.4	17.4	5.22	.60	.75	.89	57.0	16.7	5.81	.61	.77	.91	54.8	16.1	6.49	.61	.78	.93
71°F (22°C)	1550	730	63.5	18.6	4.77	.42	.54	.66	61.2	17.9	5.28	.42	.55	.67	58.9	17.3	5.88	.43	.55	.68	56.6	16.6	6.58	.43	.56	.69
	1750	825	64.5	18.9	4.82	.43	.56	.69	62.2	18.2	5.32	.43	.57	.70	59.8	17.5	5.93	.43	.57	.71	57.4	16.8	6.63	.44	.58	.73
	1950	920	65.4	19.2	4.85	.43	.57	.71	63.1	18.5	5.36	.44	.58	.73	60.5	17.7	5.97	.44	.59	.74	58.2	17.1	6.66	.44	.60	.76