

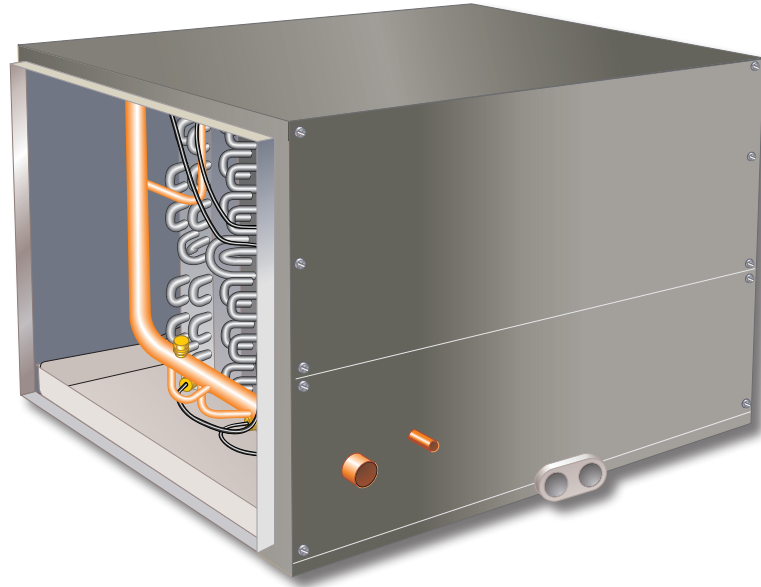

Horizontal - Cased - R-410A

**RESIDENTIAL
PRODUCT SPECIFICATIONS**

Bulletin No. 210858
April 2019
Supersedes July 2018



1.5 to 5 Tons

MODEL NUMBER IDENTIFICATION

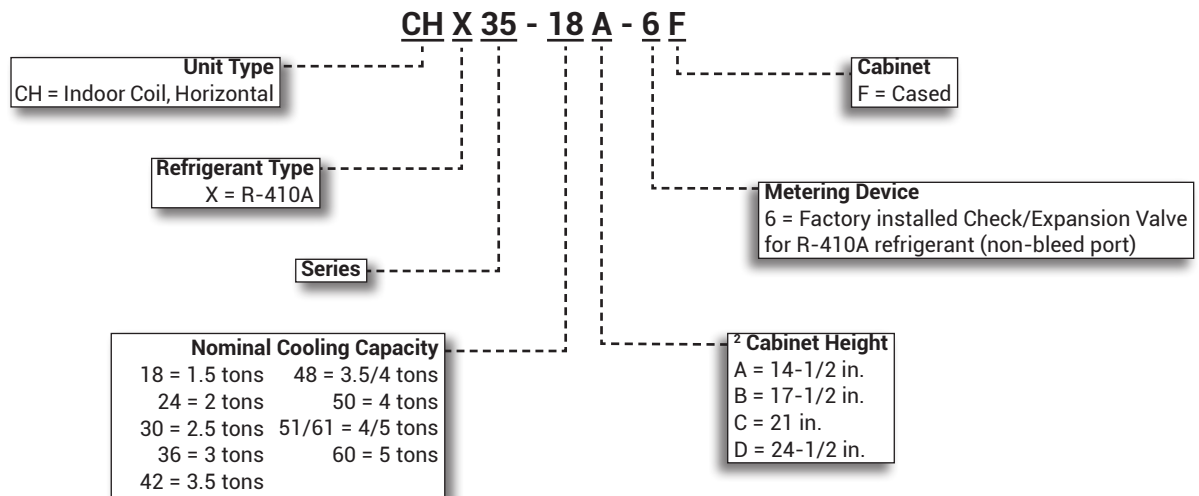

² Furnaces with the same letter designation physically match the indoor coil.

CONTENTS

Air Resistance	3
Approvals and Warranty	2
CH33 to CHX35 Cross-Reference	5
Dimensions	4
Dimensions - Furnace/Coil Combined Dimensions	5
Features	2
Model Number Identification.	1
Specifications	3

APPROVALS AND WARRANTY

APPROVALS

- Tested with matching air conditioners and heat pump units in the Lennox Research Laboratory environmental test room in accordance with AHRI Standard 210/240
- AHRI Certified system match-ups and expanded ratings, visit www.LennoxPros.com
- Air resistance tests from Lennox Laboratory air test chamber

WARRANTY

- All other covered components:
 - Limited five years in residential installations
 - Limited one year in non-residential installations

NOTE - Refer to Lennox Equipment Limited Warranty certificate included with unit for specific details.

FEATURES

APPLICATIONS

- 1.5 to 5 ton nominal sizes
- Lennox designed horizontal indoor coils can easily be installed with most Lennox horizontal furnaces
- Factory installed R-410A, check/expansion valve

COIL CONSTRUCTION

Quantum™ Coil

- Lennox designed and fabricated coil
- Aluminum tubing, hairpins, distributor and header tubes
- Copper refrigerant sweat connections on both liquid and suction lines for easy brazing
- Ripple-edged aluminum fins
- Lanced fins provide maximum exposure of fin surface to air stream
- Rifled tubing provides superior refrigerant heat transfer
- Twin coil construction assembled in an "A" configuration for large surface area
- Non-corrosive, UV-resistant polymer drain pan with dual fpt drain connections
- High pressure testing insures leakproof construction

Check/Expansion Valve

- All models have a factory-installed, internal check/expansion valve
- For use with R-410A systems
- Wide range valve
- Chatleff style fitting
- Expansion valves are externally-equalized, non-bleed port type

CABINET

- Insulated with thick fiberglass insulation
- Heavy gauge, pre-painted galvanized steel
- Flanges furnished for ease of duct connection
- Engaging holes furnished for alignment with furnace
- Removable panels provide access to coil
- Refrigerant lines extend outside of cabinet for easy connection

Furnace Match-Up

- Coils exactly match corresponding furnaces with same letter designation in model number
- No adaptor required
- Engaging holes furnished for alignment

SPECIFICATIONS

1.5 TO 3 TON

General Data		Model No.	CHX35 -18A-6F	CHX35 -24A-6F	CHX35 -24B-6F	CHX35 -30A-6F	CHX35 -30B-6F	CHX35 -36A-6F	CHX35 -36B-6F
Nominal size - tons			1.5	2	2	2.5	2.5	3	3
Factory installed expansion valve			12J18	12J18	12J18	12J18	12J18	12J19	12J19
Line connections in.	Suction o.d. - sweat		3/4	3/4	3/4	3/4	3/4	3/4	3/4
	Liquid o.d. - sweat		3/8	3/8	3/8	3/8	3/8	3/8	3/8
	Condensate drain (fpt)		(2) 3/4	(2) 3/4	(2) 3/4	(2) 3/4	(2) 3/4	(2) 3/4	(2) 3/4
Indoor Coil	Net face area sq. ft.		3.5	3.5	3.5	4.33	4.67	3.5	4.67
	Tube diameter - in.		3/8	3/8	3/8	3/8	3/8	3/8	3/8
	Number of rows		2	3	2	3	3	3	2
	Fins per inch		19	14	19	16	14	12	18
Matching Lennox Furnace - Cabinet Width Designation			A	A	B	A	B	A	B
Coil & Furnace Cabinet Height - in.			14-1/2	14-1/2	17-1/2	14-1/2	17-1/2	14-1/2	17-1/2
Shipping Data - lbs.			44	46	50	56	54	48	49

SPECIFICATIONS

3 TO 5 TON

General Data		Model No.	CHX35 -36C-6F	CHX35 -42B-6F	CHX35 -42C-6F	CHX35 -48B-6F	CHX35 -48C-6F	CHX35 -51/61C-6F	CHX35 -60D-6F
Nominal size - Tons			3	3.5	3.5	3.5/4	3.5/4	4/5	5
Factory installed expansion valve			12J19	12J20	12J20	12J20	12J20	12J20	12J20
Line connections in.	Suction o.d. - sweat		3/4	7/8	7/8	7/8	7/8	7/8	7/8
	Liquid o.d. - sweat		3/8	3/8	3/8	3/8	3/8	3/8	3/8
	Condensate drain (fpt)		(2) 3/4	(2) 3/4	(2) 3/4	(2) 3/4	(2) 3/4	(2) 3/4	(2) 3/4
Indoor Coil	Net face area sq. ft.		5.83	5.78	5.83	5.78	5.83	7.22	7.94
	Tube diameter - in.		3/8	3/8	3/8	3/8	3/8	3/8	3/8
	Number of rows		2	4	3	3	3	3	3
	Fins per inch		18	12	13	12	12	13	12
Matching Lennox Furnace - Cabinet Width Designation			C	B	C	B	C	C	D
Coil & Furnace Cabinet Height - in.			21	17-1/2	21	17-1/2	21	21	24-1/2
Shipping Data - lbs.			56	67	67	61	60	70	79

AIR RESISTANCE

Air Volume cfm	CHX35-36C-6F		CHX35-42B-6F		CHX35-42C-6F		CHX35-48B-6F		CHX35-48C-6F		CHX35-51/61C-6F		CHX35-60D-6F	
	Dry Coil	Wet Coil	Dry Coil	Wet Coil	Dry Coil	Wet Coil	Dry Coil	Wet Coil	Dry Coil	Wet Coil	Dry Coil	Wet Coil	Dry Coil	Wet Coil
800	0.06	0.08	0.10	0.10	0.06	0.06	---	---	---	---	---	---	---	---
1000	0.10	0.13	0.14	0.18	0.09	0.10	0.14	0.16	---	---	---	---	---	---
1200	0.15	0.18	0.20	0.25	0.15	0.16	0.19	0.23	0.16	0.19	0.15	0.16	---	---
1400	0.19	0.23	0.26	0.31	0.18	0.21	0.25	0.29	0.21	0.26	0.20	0.23	0.12	0.16
1600	0.24	0.31	0.34	0.36	0.26	0.28	0.30	0.38	0.27	0.30	0.25	0.29	0.16	0.20
1800	---	---	0.42	0.47	0.31	0.38	0.38	0.42	0.33	0.39	0.31	0.36	0.20	0.24
2000	---	---	---	---	---	---	---	---	0.39	0.49	0.40	0.44	0.24	0.30
2200	---	---	---	---	---	---	---	---	---	---	0.48	0.54	0.29	0.36
2400	---	---	---	---	---	---	---	---	---	---	---	---	0.34	0.42

AIR RESISTANCE

Air Volume cfm	Total Air Resistance - in. w.g.													
	CHX35-18A-6F		CHX35-24A-6F		CHX35-24B-6F		CHX35-30A-6F		CHX35-30B-6F		CHX35-36A-6F		CHX35-36B-6F	
	Dry Coil	Wet Coil	Dry Coil	Wet Coil	Dry Coil	Wet Coil	Dry Coil	Wet Coil	Dry Coil	Wet Coil	Dry Coil	Wet Coil	Dry Coil	Wet Coil
200	0.02	0.02	---	---	---	---	---	---	---	---	---	---	---	---
400	0.05	0.06	0.04	0.05	0.03	0.04	0.04	0.05	0.02	0.02	---	---	---	---
600	0.09	0.11	0.09	0.11	0.05	0.07	0.09	0.10	0.05	0.06	---	---	---	---
800	0.15	0.17	0.15	0.19	0.09	0.11	0.15	0.17	0.09	0.11	0.15	0.18	0.08	0.10
1000	0.22	0.25	0.23	0.29	0.15	0.17	0.24	0.27	0.14	0.16	0.22	0.27	0.11	0.16
1200	---	---	0.32	0.40	0.21	0.23	0.34	0.38	0.19	0.23	0.30	0.39	0.16	0.21
1400	---	---	0.43	0.50	0.28	0.30	0.45	0.51	0.26	0.30	0.41	0.48	0.21	0.27
1600	---	---	---	---	---	---	---	---	---	---	0.53	0.63	0.27	0.35

DIMENSIONS

¹ Optional right-hand airflow requires a field fabricated 6 in. (152 mm) spacer in-between the furnace and coil.

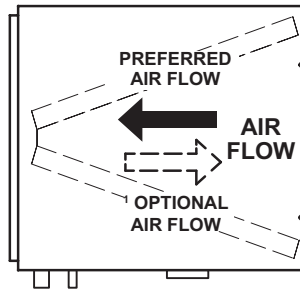

TOP VIEW

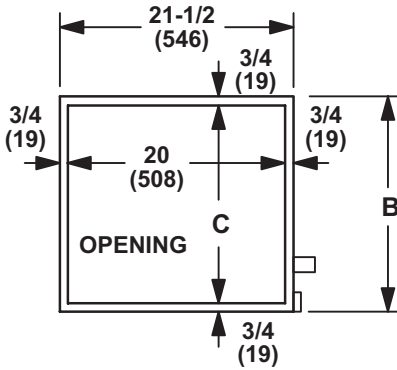

END VIEW

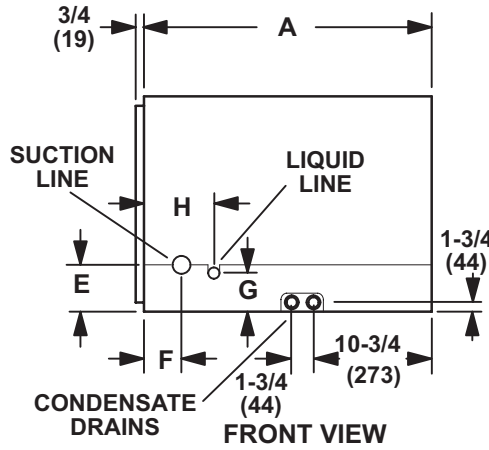

FRONT VIEW

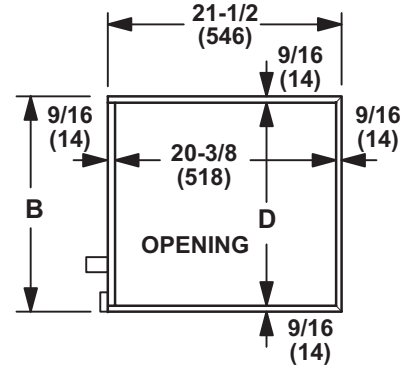

END VIEW

Model No.	A		B		C		D		E		F		G		H	
	in.	mm	in.	mm	in.	mm	in.	mm	in.	mm	in.	mm	in.	mm	in.	mm
CHX35-18A-6F	26-1/2	673	14-1/2	368	13	330	13-3/8	340	4	102	2-1/8	54	3	76	4-7/8	124
CHX35-24A-6F	26-1/2	673	14-1/2	368	13	330	13-3/8	340	4	102	2-1/8	54	3	76	4-7/8	124
CHX35-24B-6F	26-1/2	673	17-1/2	444	16	406	16-3/8	416	4	102	2-1/8	54	3	76	4-7/8	124
CHX35-30A-6F	31-1/2	800	14-1/2	368	13	330	13-3/8	340	4	102	2-1/8	54	3	76	4-7/8	124
CHX35-30B-6F	26-1/2	673	17-1/2	444	16	406	16-3/8	416	4	102	2-1/8	54	3	76	4-7/8	124
CHX35-36A-6F	26-1/2	673	14-1/2	368	13	330	13-3/8	340	4	102	2-1/8	54	3	76	4-7/8	124
CHX35-36B-6F	26-1/2	673	17-1/2	444	16	406	16-3/8	416	4	102	2-1/8	54	3	76	4-7/8	124
CHX35-36C-6F	26-1/2	673	21	533	19-1/2	495	19-7/8	505	4	102	2-1/8	54	3	76	4-7/8	124
CHX35-42B-6F	31-1/2	800	17-1/2	444	16	406	16-3/8	416	4	102	2-1/8	54	3	76	4-7/8	124
CHX35-42C-6F	26-1/2	673	21	533	19-1/2	495	19-7/8	505	4	102	2-1/8	54	3	76	4-7/8	124
CHX35-48B-6F	31-1/2	800	17-1/2	444	16	406	16-3/8	416	4	102	2-1/8	54	3	76	4-7/8	124
CHX35-48C-6F	26-1/2	673	21	533	19-1/2	495	19-7/8	505	4	102	2-1/8	54	3	76	4-7/8	124
CHX35-51/61C-6F	31-1/2	800	21	533	19-1/2	495	19-7/8	505	4	102	2-1/8	54	3	76	4-7/8	124
CHX35-60D-6F	31-1/2	800	24-1/2	622	23	584	23-3/8	594	4	102	2-1/8	54	3	76	4-7/8	124

DIMENSIONS - FURNACE/COIL COMBINED DIMENSIONS

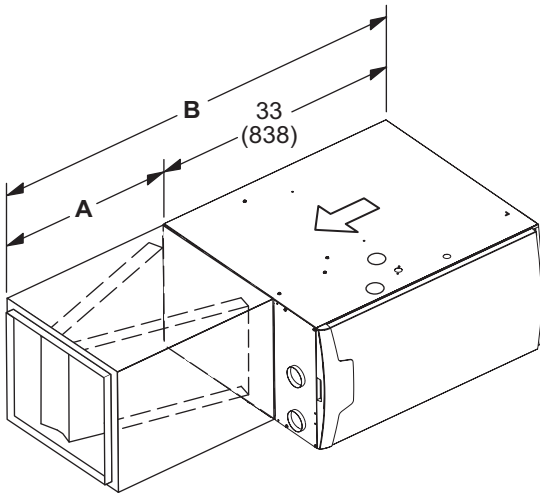

HORIZONTAL POSITION

Model No.	A		B		
	in.	mm	in.	mm	
CHX35					
CHX35-18A, CHX35-24A, CHX35-24B, CHX35-30B,	CHX35-36A, CHX35-36B, CHX35-36C, CHX35-42C, CHX35-48C	26-1/2	673	59-1/2	1511
CHX35-30A, CHX35-42B, CHX35-48B,	CHX35-51/61C, CHX35-60D	31-1/2	880	64-1/2	1638

CH33 TO CHX35 CROSS-REFERENCE

CH33 Model No.	Tons	Dimensions (H x L x D)	Order No.	CHX35 Model No.	Tons	Dimensions (H x L x D)	Order No.
CH33-18A-6F	1.5	14.5 x 21.5 x 21.5	76L01	CHX35-18A-6F	1.5	14.5 x 26.5 x 21.5	16Y02
CH33-19A-6F	1.5	14.5 x 26.5 x 21.5	18W82	CHX35-18A-6F	1.5	14.5 x 26.5 x 21.5	16Y02
CH33-25A-6F	2	14.5 x 26.5 x 21.5	18W83	CHX35-24A-6F	2	14.5 x 26.5 x 21.5	16Y03
CH33-25B-6F	2	17.5 x 26.5 x 21.5	18W84	CHX35-24B-6F	2	17.5 x 26.5 x 21.5	16Y04
CH33-24/30A-6F	2/2.5	14.5 x 26.5 x 21.5	76L03	CHX35-24A-6F	2	14.5 x 26.5 x 21.5	16Y03
¹ CH33-24/30A-6F	2/2.5	14.5 x 31.5 x 21.5	76L03	¹ CHX35-30A-6F	2.5	14.5 x 31.5 x 21.5	16Y05
CH33-31A-6F	2.5	14.5 x 31.5 x 21.5	18W85	CHX35-30A-6F	2.5	14.5 x 31.5 x 21.5	16Y05
CH33-31B-6F	2.5	17.5 x 26.5 x 21.5	18W86	CHX35-30B-6F	2.5	17.5 x 26.5 x 21.5	16Y06
CH33-36A-6F	3	14.5 x 26.5 x 21.5	76L04	CHX35-36A-6F	3	14.5 x 26.5 x 21.5	16Y07
CH33-36B-6F	3	17.5 x 26.5 x 21.5	76L07	CHX35-36B-6F	3	17.5 x 26.5 x 21.5	16Y08
CH33-36C-6F	3	21 x 26.5 x 21.5	76L10	CHX35-36C-6F	3	21 x 26.5 x 21.5	16Y09
CH33-42B-6F	3.5	17.5 x 26.5 x 21.5	76L08	CHX35-42B-6F	3.5	17.5 x 31.5 x 21.5	16Y11
CH33-43B-6F	3.5	17.5 x 31.5 x 21.5	18W87	CHX35-42B-6F	3.5	17.5 x 31.5 x 21.5	16Y11
CH33-43C-6F	3.5	21 x 26.5 x 21.5	18W88	CHX35-42C-6F	3.5	21 x 26.5 x 21.5	16Y12
CH33-44/48B-6F	4	17.5 x 31.5 x 21.5	76L09	CHX35-48B-6F	3.5/4	17.5 x 31.5 x 21.5	16Y13
CH33-48C-6F	4	21 x 26.5 x 21.5	76L11	CHX35-48C-6F	3.5/4	21 x 26.5 x 21.5	16Y14
CH33-49C-6F	4	21 x 31.5 x 21.5	18W89	CHX35-51C-6F	4	21 x 31.5 x 21.5	16Y15
CH33-50/60C-6F	4 – 5	21 x 31.5 x 21.5	76L12	CHX35-51/61C-6F	4	21 x 31.5 x 21.5	16Y15
CH33-60D-6F	5	24.5 x 26.5 x 21.5	76L13	CHX35-60D-6F	5	24.5 x 31.5 x 21.5	16Y16
CH33-62D-6F	5	24.5 x 31.5 x 21.5	76L14	CHX35-60D-6F	5	24.5 x 31.5 x 21.5	16Y16

¹ When matched with a 2.5 ton air conditioner.

REVISIONS

Sections	Description of Change
Features	Added Quantum™ coil description.



Visit us at www.lennox.com

For the latest technical information, www.LennoxPros.com

Contact us at 1-800-4-LENNOX

NOTE - Due to Lennox' ongoing commitment to quality, Specifications, Ratings and Dimensions subject to change without notice and without incurring liability. Improper installation, adjustment, alteration, service or maintenance can cause property damage or personal injury. Installation and service must be performed by a qualified installer and servicing agency.

©2019 Lennox Industries, Inc.