



Oil-Fired Hot Water Boiler

Bulletin No. 210654
September 2015
Supersedes September 2012

PRODUCT SPECIFICATIONS



AFUE up to 85.2%
Heating Input – 105,000 to 245,000 Btuh

MODEL NUMBER IDENTIFICATION

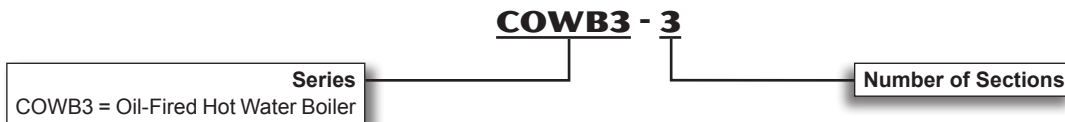

FEATURES

CONTENTS

Dimensions	5
Features.....	1
Installation Clearances	5
Model Number Identification	1
Optional Accessories	4
Specifications.....	4

WARRANTY

Cast iron boiler assembly - Limited twenty-year warranty in residential applications only.
All other covered components - Limited five-year warranty in residential applications.
Refer to Lennox Equipment Limited Warranty certificate included with equipment for details.

FEATURES

APPROVALS

Annual Fuel Utilization Efficiencies are based on US Department of Energy test procedures and Federal Trade Commission labeling regulations.

Units are certified by AHRI.

Boilers also carry listings and approvals by CSA.

Boiler heat exchanger assemblies are constructed and hydrostatically tested in accordance with American Society of Mechanical Engineers (ASME) Boiler and Pressure Vessel Code Section IV Standards for cast iron heating boilers.

APPLICATIONS

Oil-fired hot water boilers are available in six sizes with heating inputs of 105,000 to 245,000 Btuh.

AFUE of up to 85.2%

Boilers may be used in a wide variety of applications including radiant floor heating, baseboard heating and zoned heating systems.

Compact size allows easy installation in a basement or utility room.

All units are completely factory assembled with all controls installed and wired.

HEATING SYSTEM

Beckett Oil Burner

Smooth operating, high-pressure atomizing type burner blends oil and air for maximum efficiency.

Heavy-duty permanent split capacitor (PSC) motor drives quiet operating blower wheel and fuel pump.

Flame retention head is designed to agitate and mix oil and air for complete combustion and highest efficiency.

Burner has 10,000 volt ignition transformer and ceramic glazed electrodes which provide a safe, continuous flame.

Equipped with a factory installed cadmium sulfide cell flame detector and primary safety control that provides complete shutdown in case of flame failure.

Interrupted-duty primary control features 15 second prepurge and limited recycle and limited reset controls.

All burner parts are easily removed for servicing.

Burner is certified according to ANSI Standard 296.6.

Burner is factory installed in the unit, wired and tested.

Burner is shipped with nozzles for dual input/output firing rate. See Specifications tables for ratings. Field installation of nozzle is required.

Burner mounted swing door allows complete access to combustion chamber and burner end cone for set-up, maintenance and cleaning. Eliminates complete burner removal.

Solenoid delay oil valve ensures positive fuel shut-off and eliminates "after-drip". Also provides improved burner operation, cleaner combustion and quiet operation.

Cast Iron Boiler Assembly

Boiler sections and push nipples are constructed of long life cast iron.

Boiler sections and push nipples expand and contract together, providing positive watertight seal.

Thermal pin design increases heat transfer efficiency.

Wet base design allows water circulation over complete heat exchanger surface for maximum heat transfer.

Boiler components are easily accessible for cleaning and servicing.

Target wall of combustion chamber is constructed of vacuum formed refractory ceramic fiber allowing maximum high temperatures for more complete combustion and higher efficiencies.

Peephole in the cast iron burner swing door allows flame inspection.

Jacket attaches directly to cast iron heat exchanger for increased stability when handling product.

Water Circulating Pump (Not Furnished in Canada)

Heavy duty pump is constructed of cast iron.

Bronze isolation ball type valves on inlet and outlet of pump eliminate need to drain system if pump servicing is required.

Pump motor is impedance protected.

Motor and impeller is removeable as a single unit for servicing.

Pump is shipped wired to boiler ready for field installation in a supply side pumping mode.

Relief Valve

Furnished as standard for field installation in rear of cabinet.

Valve provides for pressure relief of heating system in case of abnormal operating conditions.

Valve opens at 30 psig and is approved by ASME.

Brass Drain Valve

3/4 in. brass drain valve is furnished for field installation in drain outlet on front of cabinet.

See dimension drawing for location.

FEATURES

HEATING SYSTEM (continued)

Optional Accessories

Tankless Hot Water Coil

Tankless water heater coil supplies a moderate amount of instantaneous hot water for kitchen, bath and laundry usage.

Limit control is factory wired for field installation on tankless coil control well to maximize hot water heating performance for instantaneous heating.

Raised coil port extends through jacket to allow easy servicing and inspection of tankless coil without removing panels.

Water line connections are furnished on side of boiler cabinet. See dimension drawing.

VENTING

Barometric Draft Control

Furnished as standard equipment for field installation in flue pipe.

Flue Brush

Furnished with unit for cleaning flue passageways.

CONTROLS

High Limit and Circulator Relay Control

Factory installed, immersion type limit control gives protection against abnormal operating conditions.

Control monitors water temperature and delays burner start-up until any residual heat has been utilized first. Thermal purge logic measures rate of temperature change inside the boiler and delays burner firing accordingly. Maximizes efficiency by operating burner only when needed.

Operation with optional Tankless Hot Water Coil - Low Limit Control seeks maximum temperature to satisfy domestic hot water call bypassing thermal purge logic.

Limit control is adjustable from 140°F to 240°F.

Circulator relay operates pump during thermostat demand.

Display LEDs - Three, seven segment LEDs display alpha-numeric information related to diagnostics as well as system operation and status. Diagnostic codes are held in non-volatile memory, immune from power interruptions. Factory installed on front of cabinet.

Combination Temperature/Pressure Gauge

Located on top of unit cabinet.

Monitors system for safe and reliable operation.

Optional Accessories

Thermostat

See Thermostat bulletins in Controls section and Lennox Price Book for a complete list of thermostats.

CABINET

Constructed of heavy gauge steel with a baked-on enamel paint finish.

Cabinet is fully insulated with fiberglass insulation, keeping cabinet surface temperatures low.

Controls are shipped factory installed on cabinet.

Top and front cabinet access allows easy cleaning and servicing of unit.

SPECIFICATIONS

		Model No.	COWB3-3	COWB3-4	COWB3-5
Oil Heating Performance	Input - Btuh	Low Fire Nozzle	105,000	175,000	245,000
		High Fire Nozzle	140,000	210,000	---
	¹ Output - Btuh	Low Fire Nozzle	92,000	151,000	210,000
		High Fire Nozzle	120,000	179,000	---
	² Net AHRI I=B=R rating - Btuh	Low Fire Nozzle	80,000	131,000	183,000
		High Fire Nozzle	104,000	156,000	---
	³ AFUE	Low Fire Nozzle	85.2%	85.0%	84.3%
		High Fire Nozzle	84.0%	84.0%	---
Boiler	Number of boiler sections		3	4	5
	Net boiler heating surface - sq. ft.		18.54	25.16	31.78
	Boiler capacity - U.S. gallons		9.6	11.6	13.7
⁴ Nozzle Ratings	U.S. gallons/min.	Low Fire Nozzle	0.75	1.25	1.75
		High Fire Nozzle	1.00	1.50	---
Oil Burner Pump	Factory setting 100 psi		1 stage	1 stage	1 stage
Connections in.	Oil piping size N.P.T.		1/4	1/4	1/4
	Flue size diameter		6	6	6
	Water supply size N.P.T.		1-1/4	1-1/4	1-1/4
	Water return size N.P.T.		1-1/4	1-1/4	1-1/4
	Drain connection size N.P.T.		3/4	3/4	3/4
Shipping Data - lbs. (1 package)			492	575	673
Electrical characteristics			120 volts - 60 hertz - 1 phase (less than 12 amps)		

OPTIONAL ACCESSORIES

See Lennox Price Book For Complete Listing of Optional Accessories

⁵ Tankless Water Heater	Catalog Number	27M20	27M20	27M20	
		U.S. gallons/min. Low Fire Nozzle	3.00	3.50	4.00
		High Fire Nozzle	3.25	3.75	4.25

NOTE - Circulating pump is not furnished in Canada and must be field supplied.

¹ Heating capacity based on 13% CO₂ with 0.02 in. w.g. draft over fire and #1 smoke or less.

² Net AHRI ratings indicate the amount of equivalent direct radiation each boiler will produce under normal conditions and thermostatic control. Ratings based on an allowance of 1.15 in accordance with the factors shown on the I=B=R Standard as published by The Hydronics Institute. Selection of boiler size should be based on "Net I=B=R Rating" being equal to or greater than the calculated heat loss of the building.

³ Annual Fuel Utilization Efficiency based on U.S. DOE test procedures and FTC labeling regulations.

⁴ Based on 140,000 Btuh per gallon.

⁵ Water heated from 40°F to 140°F with 200°F boiler water temperature, intermittent draw.

DIMENSIONS - INCHES (MM)

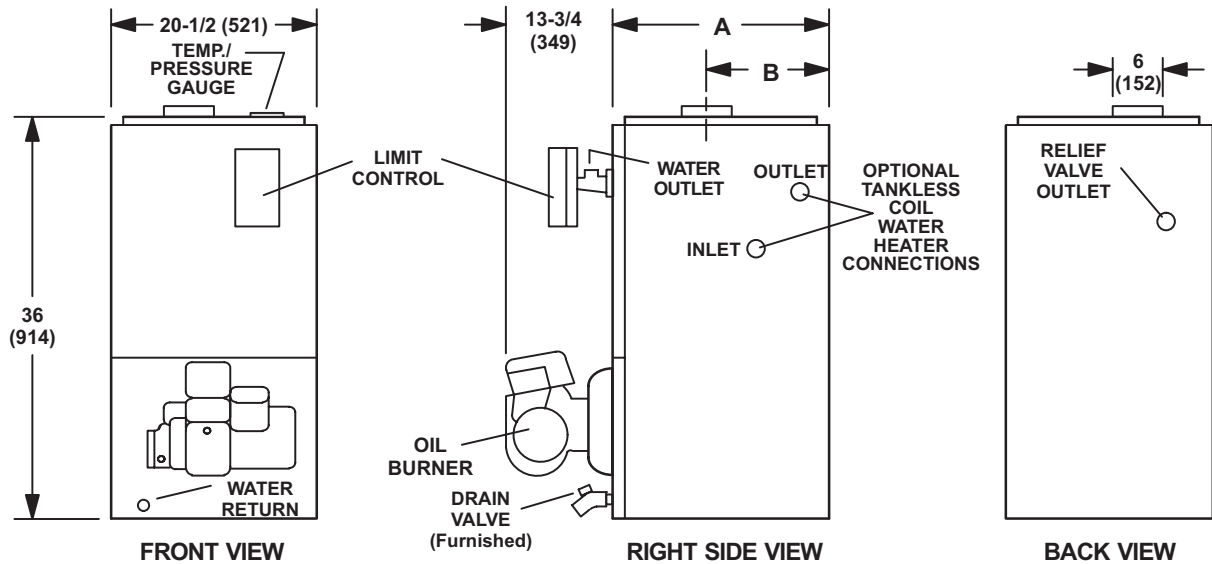

Model No.	A		B	
	in.	mm	in.	mm
COWB3-3	14-1/2	368	8	203
COWB3-4	17-3/4	451	9-5/8	244
COWB3-5	21	533	11-1/2	292

INSTALLATION CLEARANCES

Side	6 inches (152 mm)
Side with optional tankless coil	18 inches (457 mm)
Rear	6 inches (152 mm)
Top	6 inches (152 mm)
Top (Service)	18 inches (457 mm)
Front	18 inches (457 mm)
Front (Service)	24 inches (610 mm)
¹ Floor	*Non-Combustible
Flue Pipe to Combustible	18 inches (457 mm)

NOTE - If boiler is installed in a confined space, two ventilation openings must be provided into the space; one at least 12 inches (305 mm) from the top and one at least 12 inches (305 mm) from the bottom. Each opening should have a minimum free area of 1 in.2 (645 mm²) per 1000 Btu per hour (0.93 kW per hour) (inside air) of the total input rating of all equipment in confined area. For applications with outside air, each opening should have a minimum free area of 1 in.2 (645 mm²) per 4000 Btu per hour (1.17 kW per hour) for vertical ducts and 2000 Btu per hour (0.59 kW per hour) for horizontal ducts to the outside.

NOTE - In the U.S. flue sizing must conform to the methods outlined in the current National Fuel Gas Code (NFPA 54/ANSI-Z223.1) or applicable provisions of local building codes. In Canada flue sizing must conform to the methods outlined in National Standard of Canada CAN/CSA-B149.1.

¹ Clearance for installation on combustible floor if combustible flooring base (field supplied) is installed between the boiler and the combustible floor.

REVISIONS

Section	Description
Warranty	Warranty for covered components in residential applications has been extended from 1 year to 5 years.

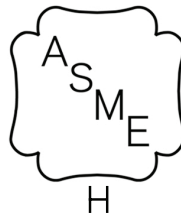

Visit us at www.lennox.com

For the latest technical information, www.lennoxravenet.com

Contact us at 1-800-4-LENNOX

NOTE - Due to Lennox' ongoing commitment to quality, Specifications, Ratings and Dimensions subject to change without notice and without incurring liability. Improper installation, adjustment, alteration, service or maintenance can cause property damage or personal injury. Installation and service must be performed by a qualified installer and servicing agency.

©2015 Lennox Industries, Inc.