

**CR22 SERIES EVAPORATOR UNITS — DOWN-FLO
AIR-CONDITIONING AND HEAT PUMP** **CR22***** 13,000 to 63,000 Btuh (3.8 to 18.5 kW) Cooling Capacity**

*ARI Standard 210/240 Certified Ratings with Matching Outdoor Unit

Bulletin #210016

October 1993

Supersedes March 1993

Applications — Lennox designed and built down-flo evaporator coils can easily be installed with most Lennox down-flo furnaces. Coils match openings of most Lennox furnaces. See Coil/Furnace Match-up Selector table in this bulletin for more information. Coils are also designed for use with matching B24 series blower units. See Coil/B24 Match-up Selector table in this bulletin and B24 blower unit bulletin indexed in this section. All units are shipped with factory installed expansion and check valve. See condensing units bulletins (section Cooling Units — Condensing Units) for evaporator unit applications and cooling capacities. See heat pump outdoor unit bulletins (section Heat Pumps — Matched remote Systems) for indoor coil applications and cooling and heating capacities. See FM21 bulletin in Heat Pumps — Matched Remote Systems for more information on heat pump systems.

Cabinet Construction — Cabinets are constructed of heavy gauge steel with a deluxe baked-on enamel paint finish and are fully insulated with thick fiberglass insulation. Removable panel allows access for easy servicing. Refrigerant lines extend outside of cabinet for ease of connection.

Coil Construction — Lennox designed and fabricated coils are constructed of precisely spaced ripple-edged enhanced aluminum fins machine fitted to rifled copper tubes. Lanced fins allow for maximum exposure of fin surface to air stream. Copper rifled tubing construction provides long coil life and ease of service. Rifled tubing provides superior refrigerant flow resulting in maximum heat transfer. Twin coils assembled in an "A" configuration provides extra large surface and contact area for maximum efficiency. Fins have collars that grip tubing for maximum contact area resulting in excellent heat transfer. Flared shoulder tubing joints and silver soldering provide tight leakproof joints. Coils are thoroughly tested under pressure to insure leakproof construction. Drainpan is constructed of a non-corrosive polymer and has dual 3/4 inch (19 mm) fpt drain connections. Two-piece end panel on coil allows easy access for coil servicing and cleaning. Refrigerant lines are equipped with sweat connections on suction (vapor) line and liquid line.

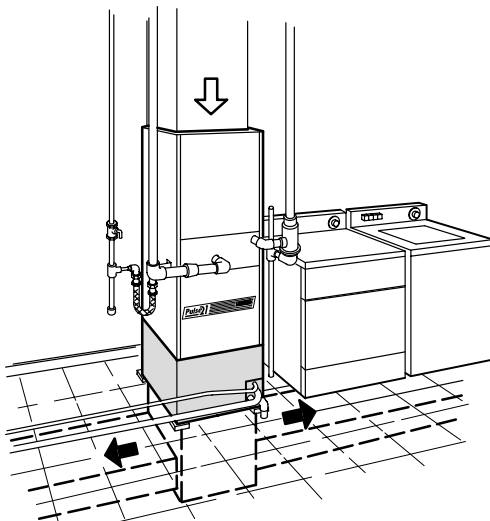
Typical ApplicationsUtility Room Installation
With Pulse 21[®] Furnace

Fully Tested — Evaporator units have been thoroughly tested with matching condensing and heat pump units in the Lennox Research Laboratory environmental test room. Air resistance data is from tests conducted in the Lennox air test chamber. Coil assemblies are shipped factory assembled and ready for installation.

Furnace Support Kit (Optional) — Kit (41J22) is required to provide additional support when matching 21-1/4 in. (540 mm) wide furnaces with CR22-51 and CR22-65 coils.

SPECIFICATIONS

Model No.		CR22-21-TXV	CR22-31-TXV	CR22-31W-TXV	CR22-41-TXV	CR22-51-TXV	CR22-65-TXV
Evaporator Coil	Net face area — sq. ft. (m ²)	3.11 (0.29)	4.0 (0.37)	4.0 (0.37)	4.44 (0.41)	7.58 (0.70)	7.58 (0.70)
	Tube diameter — in. (mm)	3/8 (9.5)	3/8 (9.5)	3/8 (9.5)	3/8 (9.5)	3/8 (9.5)	3/8 (9.5)
	No. of rows	2	3	3	3	2	3
	Fins per inch (m)	15 (590)	12 (472)	12 (472)	12 (472)	15 (590)	12 (472)
Suction (vapor) line connection — in. (mm) sweat		5/8 (15.9)	3/4 (19)	3/4 (19)	3/4 (19)	7/8 (22.2)	1-1/8 (28.6)
Liquid line connection — in. (mm) sweat		3/8 (9.5)	3/8 (9.5)	3/8 (9.5)	3/8 (9.5)	3/8 (9.5)	3/8 (9.5)
Condensate drain (fpt) — in. (mm)		(2) 3/4 (19)	(2) 3/4 (19)	(2) 3/4 (19)	(2) 3/4 (19)	(2) 3/4 (19)	(2) 3/4 (19)
Refrigerant		R-22	R-22	R-22	R-22	R-22	R-22
Coil shipping weight — lbs. (kg) 1 package		39 (18)	52 (24)	56 (25)	65 (29)	86 (39)	97 (44)
*Expansion Device Furnished		Expansion And Check Valve					
**Furnace Support Kit (Optional)		Not Available				41J22	

*Furnished and factory installed.

**Required when matching 21-1/4 in. (540 mm) wide furnaces with CR22-51 and CR22-65 coils.

AIR RESISTANCE

Model No.	Air Volume		Total Resistance	
	cfm	L/s	in. w.g.	Pa
CR22-21	300	140	.04	10
	400	190	.07	17
	500	235	.11	27
	600	285	.15	37
	700	330	.20	50
CR22-31	600	285	.13	32
	800	380	.22	55
	1000	470	.33	82
	1200	570	.47	117
	1400	660	.62	154
CR22-31W	600	285	.13	32
	800	380	.22	55
	1000	470	.33	82
	1200	570	.47	117
	1400	660	.62	154

Model No.	Air Volume		Total Resistance	
	cfm	L/s	in. w.g.	Pa
CR22-41	800	380	.15	37
	1000	470	.23	57
	1200	570	.32	80
	1400	660	.42	104
	1600	760	.54	134
CR22-51	1200	570	.17	42
	1400	660	.23	57
	1600	760	.29	72
	1800	850	.36	90
	2000	940	.43	107
	2200	1040	.52	129
CR22-65	1600	760	.23	57
	1800	850	.29	72
	2000	940	.35	87
	2200	1040	.42	104
	2400	1130	.49	122

CR22 COIL TO FURNACE MATCHING SELECTOR

Furnace Model No.		Coil Model Number					
		CR22-21	CR22-31	CR22-31W	CR22-41	CR22-51	CR22-65
G20RE G20RX	Q2/3-50						
	Q3-75						
	Q4-75					XX	
	Q3/4-100					XX	
	Q5-100						
	Q3-125						
	Q4/5-125						
G20RE	Q4/5-150					X	X
GSR21	Q3-50						
	Q4-50					XX	
	Q3-80					XX	
	Q4/5-80					XX	XX
	Q4/5-100					XX	XX
GSR21	V3-80					XX	
	V5-80					XX	XX
	V5-100					XX	XX
G24M	2-45	X	X	X			
	2-60	X	X	X			
	3-60		X	X	X		
	2-75	X	X	X			
	3-75		X	X	X		
	4-75		X	X	X	XX	
	3/4-100		X	X	X	XX	
	4/5-100					XX	XX
	3/4-120					XX	
	4/5-120					XX	XX
	4/5-140					XX	XX
OSR20	Q3-105/120		X	X	X		
	Q5-140/154				X	XX	XX

- Coil matches furnace and air volume.
- X** Coil matches air volume. Coil does not match furnace physically and requires field fabricated transition.
- XX** Coil matches air volume. Coil does not match furnace physically and requires field fabricated transition. Requires Furnace Support Kit (41J22).
- Coil matches furnace physically. Check furnace air volume and total system pressure drop for satisfactory match with coil.
- XX** Coil does not match furnace physically and requires field fabricated transition. Check furnace air volume and total system pressure drop for satisfactory match. Requires Furnace Support Kit (41J22).
- Does not match.

CR22 COIL TO B24 BLOWER UNIT MATCHING SELECTOR

Blower Model No.		Coil Model Number					
		CR22-21	CR22-31	CR22-31W	CR22-41	CR22-51	CR22-65
B24	Q2						
	Q3						
	Q3.5						
	Q4/5						

- Coil matches B24 blower and air volume.
- Does not match

NOTE — Table shows match-ups by dimension only. Pressure drop of individual coils must be calculated with blower capacities and system airflow requirements for a satisfactory match.

DIMENSIONS — inches (mm)

NOTE — Coil cabinet is equipped with a 5/8 inch (16mm) flange on top of cabinet that may be bent up for plenum connection when used with B24 Series Blower Units in down-flo applications. When coil is used in conventional down-flo furnace applications, flange should be bent in.
 *Dimensions before flange is bent.
 **Dimensions after flange is bent.

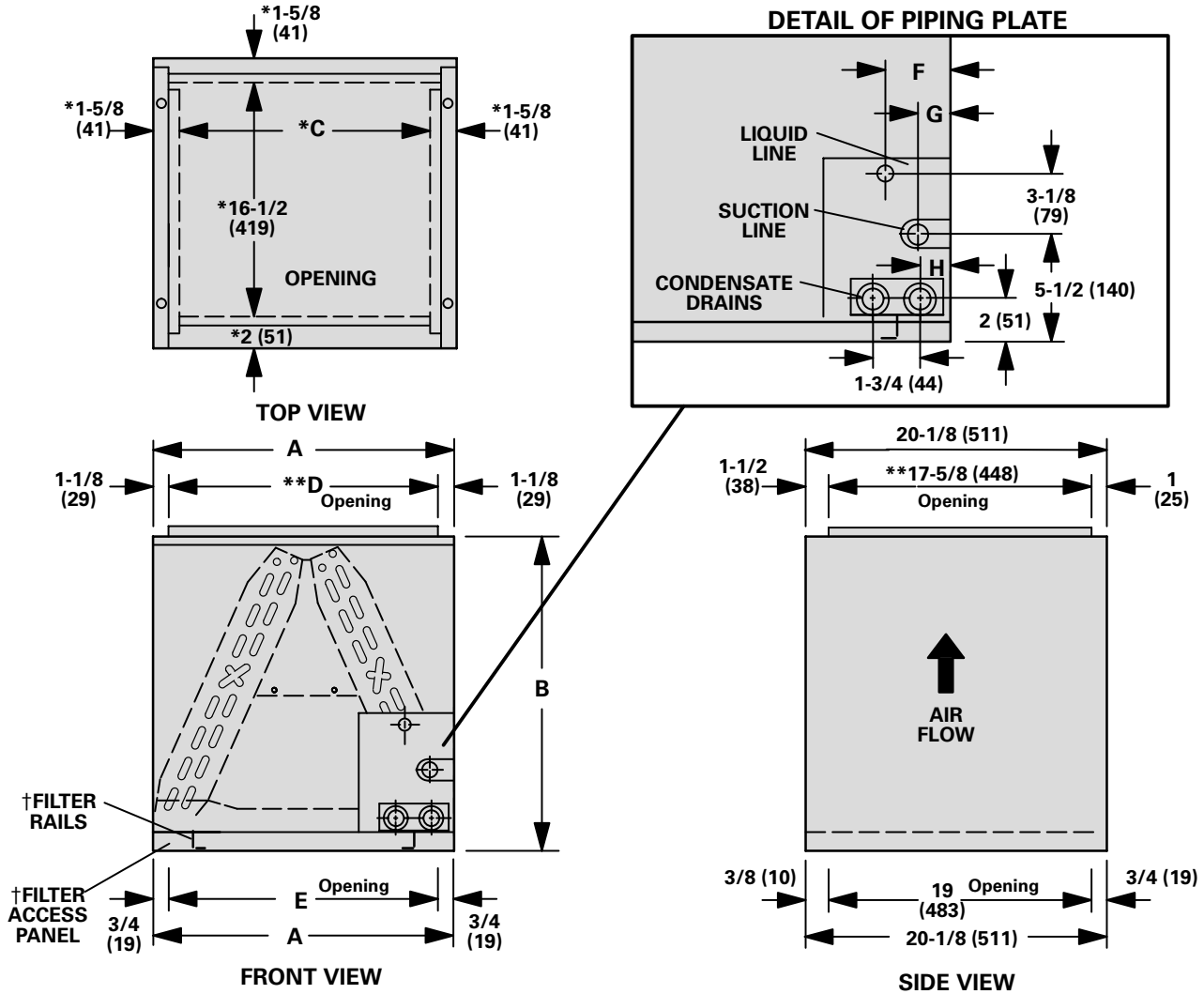

Model No.	A		B		C		D		E		F		G		H	
	in.	mm	in.	mm	in.	mm	in.	mm	in.	mm	in.	mm	in.	mm	in.	mm
CR22-21	16-1/4	413	17	432	13	330	14	356	14-3/4	375	4-1/8	105	2-1/8	54	1-7/8	48
CR22-31	16-1/4	413	21	533	13	330	14	356	14-3/4	375	4-1/8	105	2-1/8	54	1-7/8	48
CR22-31W	21-1/4	540	21	533	18	457	19	483	19-3/4	502	6-5/8	168	4-5/8	117	4-3/8	111
CR22-41	21-1/4	540	25-3/4	654	18	457	19	483	19-3/4	502	4-1/8	105	2-1/8	54	1-7/8	48
CR22-51 CR22-65	26-1/4	667	28-3/4	730	23	584	24	629	24-3/4	629	4-1/8	105	2-1/8	54	1-7/8	48