



INDOOR COILS CX35 (-20)

Upflow - Cased - R-410A

Bulletin No. 210879

November 2018

Supersedes Bulletin No. 210668

PRODUCT SPECIFICATIONS

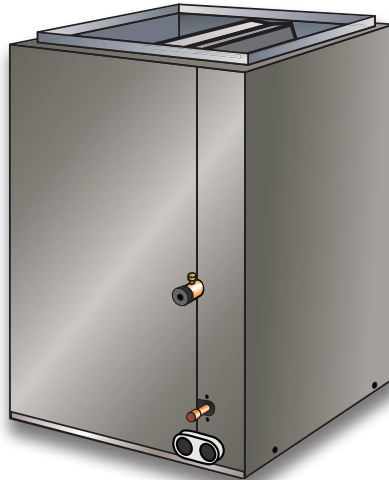

1.5 to 5 Tons

MODEL NUMBER IDENTIFICATION

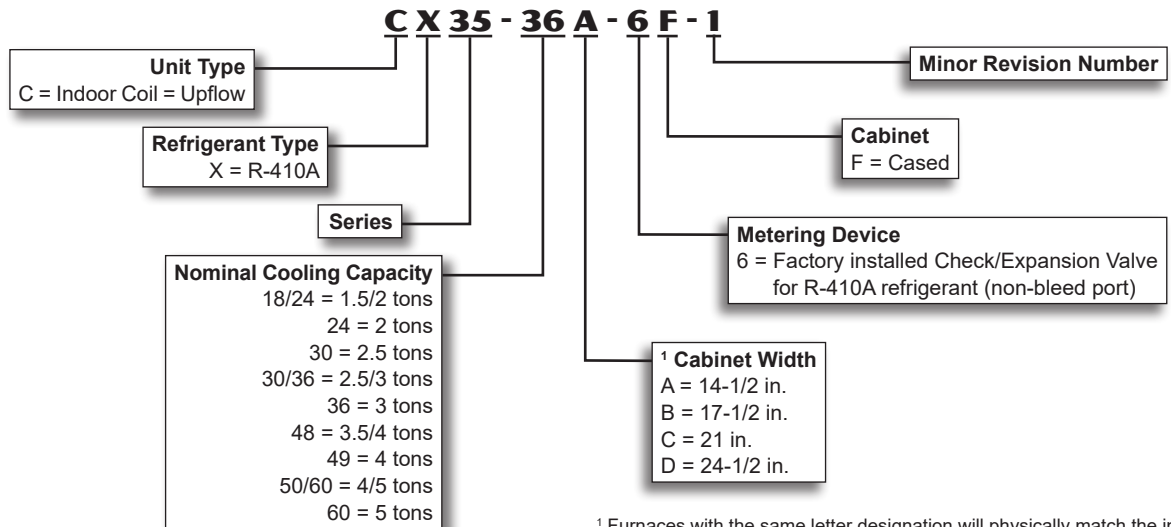

¹ Furnaces with the same letter designation will physically match the indoor coil.

FEATURES

CONTENTS

Air Resistance.....	4
CX34 To CX35 Cross-Reference.....	8
Dimensions.....	5
Features.....	1
Model Number Identification.....	1
Specifications.....	2

WARRANTY

All Covered Components - Limited warranty for five years in residential applications, one year warranty in non-residential applications.
Refer to Lennox Equipment Limited Warranty certificate included with equipment for details.

APPLICATIONS

Lennox designed upflow cased indoor coils can easily be installed with most Lennox upflow furnaces.
Factory installed R-410A, check/expansion valve.
See Product Specifications in section Air Conditioners or Heat Pump Outdoor Units for indoor coil applications and cooling capacities.

TESTING

Tested with matching air conditioners and heat pump units.
Rated in accordance with AHRI Standard 210/240-2008 conditions and DOE test procedures.
Air resistance tests from Lennox Laboratory air test chamber.

FEATURES

COIL CONSTRUCTION

Quantum™ Coil

Lennox designed and fabricated coil.

Aluminum tubing, hairpins, distributor and header tubes.

Copper refrigerant sweat connections on both liquid and suction lines for easy brazing.

Ripple-edged aluminum fins.

Lanced fins provide maximum exposure of fin surface to air stream.

Rifled tubing provides superior refrigerant heat transfer.

Twin coil construction assembled in a “A” configuration for large surface area.

Non-corrosive, UV-resistant polymer drain pan with dual fpt drain connections.

High pressure testing insures leakproof construction.

Check/Expansion Valve

All models have a factory-installed, internal check/expansion valve.

For use with R-410A systems.

Wide range valve.

Chatleff style fitting.

Expansion valves are externally-equalized, non-bleed port type.



CABINET

Cabinets insulated with thick fiberglass insulation.

Constructed of pre-painted heavy gauge steel.

Flanges provided in outlet opening of cabinet for ease of plenum connection.

Removable panels provide access to coil.

See dimension drawing.

Furnace Match-Up

Coils exactly match corresponding furnaces with same letter designation in model number. No adaptor required.

Engaging holes furnished on cabinet for alignment with furnace.

SPECIFICATIONS

1.5 TO 2 TON

General Data		Model No.	CX35-18/24A-6F	CX35-18/24B-6F	CX35-24A-6F	CX35-24B-6F
Nominal size - Tons			1.5 / 2	1.5 / 2	2	2
Line Connections in.	Suction / vapor o.d. - sweat		3/4	3/4	3/4	3/4
	Liquid o.d. - sweat		3/8	3/8	3/8	3/8
	Condensate drain (fpt)		(2) 3/4	(2) 3/4	(2) 3/4	(2) 3/4
Indoor Coil	Net face area sq. ft.		3.11	3.11	3.55	3.55
	Tube diameter - in.		3/8	3/8	3/8	3/8
	Number of rows		2	2	3	3
	Fins per inch		18	18	14	14
Matching Lennox Furnace - Cabinet Width Designation			A	B	A	B
Coil & Furnace Cabinet Width - in.			14-1/2	17-1/2	14-1/2	17-1/2
Shipping Data - lbs.			30	34	38	43

SPECIFICATIONS		2.5 TO 3 TON			
General Data	Model No.	CX35-30A-6F	CX35-30B-6F	CX35-30/36A-6F	CX35-30/36B-6F
	Nominal size - Tons	2.5	2.5	2.5 / 3	2.5 / 3
Line Connections in.	Suction / vapor o.d. - sweat	3/4	3/4	3/4	3/4
	Liquid o.d. - sweat	3/8	3/8	3/8	3/8
	Condensate drain (fpt)	(2) 3/4	(2) 3/4	(2) 3/4	(2) 3/4
Indoor Coil	Net face area sq. ft.	4.44	4.44	4.89	5.77
	Tube diameter - in.	3/8	3/8	3/8	3/8
	Number of rows	3	3	2	2
	Fins per inch	13	13	18	18
Matching Lennox Furnace - Cabinet Width Designation		A	B	A	B
Coil & Furnace Cabinet Width - in.		14-1/2	17-1/2	14-1/2	17-1/2
Shipping Data - lbs.		45	50	41	45

SPECIFICATIONS		2.5 TO 4 TON				
General Data	Model No.	CX35-30/36C-6F	CX35-36A-6F	CX35-36B-6F	CX35-48B-6F	CX35-48C-6F
	Nominal size - Tons	2.5 / 3	3	3	3.5 / 4	3.5 / 4
Line Connections in.	Suction / vapor o.d. - sweat	3/4	3/4	3/4	7/8	7/8
	Liquid o.d. - sweat	3/8	3/8	3/8	3/8	3/8
	Condensate drain (fpt)	(2) 3/4	(2) 3/4	(2) 3/4	(2) 3/4	(2) 3/4
Indoor Coil	Net face area sq. ft.	5.77	4.89	4.89	5.77	5.77
	Tube diameter - in.	3/8	3/8	3/8	3/8	3/8
	Number of rows	2	3	3	3	3
	Fins per inch	18	14	14	13	13
Matching Lennox Furnace - Cabinet Width Designation		C	A	B	B	C
Coil & Furnace Cabinet Width - in.		21	14-1/2	17-1/2	17-1/2	21
Shipping Data - lbs.		48	46	50	55	60

SPECIFICATIONS		4 TO 5 TON			
General Data	Model No.	CX35-49C-6F	CX35-50/60C-6F	CX35-60C-6F	CX35-60D-6F
	Nominal size - Tons	4	4 / 5	5	5
Line Connections in.	Suction / vapor o.d. - sweat	7/8	7/8	7/8	7/8
	Liquid o.d. - sweat	3/8	3/8	3/8	3/8
	Condensate drain (fpt)	(2) 3/4	(2) 3/4	(2) 3/4	(2) 3/4
Indoor Coil	Net face area sq. ft.	7.0	5.78	7.50	7.58
	Tube diameter - in.	3/8	3/8	3/8	3/8
	Number of rows	3	3	3	3
	Fins per inch	15	12	16	14
Matching Lennox Furnace - Cabinet Width Designation		C	C	C	D
Coil & Furnace Cabinet Width - in.		21	21	21	24-1/2
Shipping Data - lbs.		70	60	73	72

AIR RESISTANCE

Model No.	Air Volume cfm	Total Resistance	
		Dry Coil	Wet Coil
		in. w.g.	in. w.g.
CX35-18/24A-6F CX35-18/24B-6F	400	0.06	0.08
	600	0.11	0.17
	800	0.18	0.25
	1000	0.27	0.39
	1200	0.37	0.52
CX35-24A-6F	400	0.05	0.05
	600	0.09	0.10
	800	0.16	0.18
	1000	0.23	0.26
	1200	0.32	0.36
CX35-24B-6F	400	0.03	0.04
	600	0.07	0.09
	800	0.11	0.15
	1000	0.17	0.22
	1200	0.23	0.31
CX35-30A-6F	600	0.07	0.08
	800	0.12	0.13
	1000	0.18	0.20
	1200	0.26	0.28
	1400	0.34	0.37
CX35-30B-6F	600	0.06	0.06
	800	0.09	0.11
	1000	0.13	0.16
	1200	0.19	0.23
	1400	0.25	0.31
CX35-30/36A-6F	800	0.13	0.14
	1000	0.19	0.21
	1200	0.27	0.30
	1400	0.34	0.39
	1600	0.45	0.51
CX35-30/36B-6F CX35-30/36C-6F CX35-36B-6F	800	0.08	0.11
	1000	0.13	0.16
	1200	0.17	0.21
	1400	0.22	0.28
	1600	0.29	0.34

Model No.	Air Volume cfm	Total Resistance	
		Dry Coil	Wet Coil
		in. w.g.	in. w.g.
CX35-36A-6F	800	0.13	0.14
	1000	0.19	0.21
	1200	0.27	0.30
	1400	0.34	0.39
	1600	0.45	0.51
CX35-48B-6F	1000	0.13	0.13
	1200	0.18	0.18
	1400	0.23	0.24
	1600	0.30	0.31
	1800	0.37	0.40
CX35-48C-6F	1000	0.07	0.09
	1200	0.10	0.12
	1400	0.13	0.16
	1600	0.16	0.20
	1800	0.20	0.24
CX35-49C-6F	1200	0.08	0.12
	1400	0.13	0.17
	1600	0.17	0.22
	1800	0.22	0.28
	2000	0.28	0.35
CX35-50/60C-6F	1200	0.13	0.17
	1400	0.18	0.23
	1600	0.23	0.29
	1800	0.28	0.37
	2000	0.34	0.43
CX35-60D-6F	1400	0.11	0.15
	1600	0.14	0.18
	1800	0.17	0.21
	2000	0.21	0.27
	2200	0.25	0.32
	2400	0.30	0.37
CX35-60C-6F	1400	0.15	0.19
	1600	0.19	0.23
	1800	0.24	0.28
	2000	0.29	0.34
	2200	0.33	0.40
	2400	0.39	0.46

DIMENSIONS - INCHES (MM)

CX35-18/24(A/B), -30/36(A/B/C) and -36(A/B) Coils

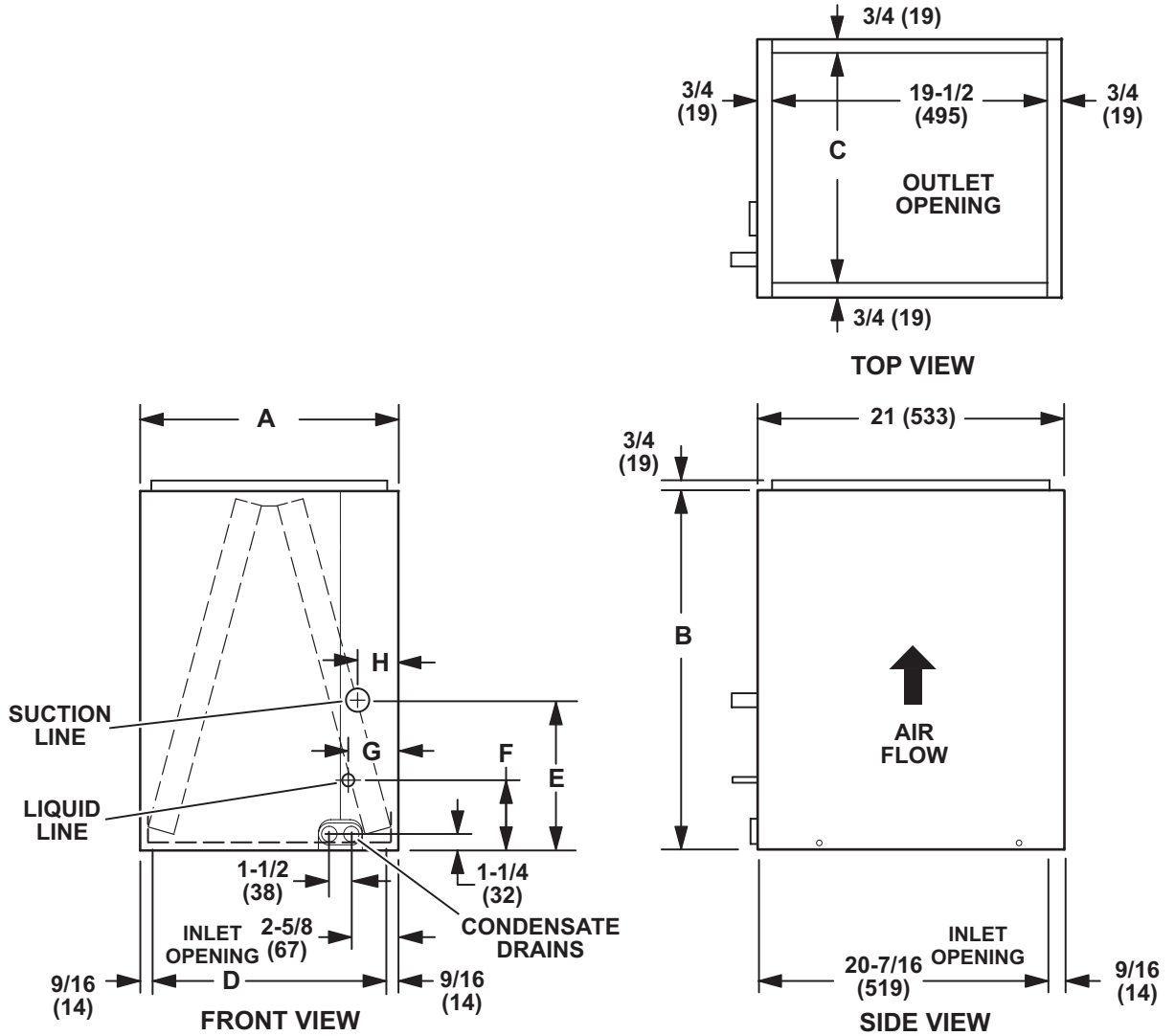

Model Number	A		B		C		D		E		F		G		H	
	in.	mm	in.	mm	in.	mm	in.	mm	in.	mm	in.	mm	in.	mm	in.	mm
CX35-18/24A-6F	14-1/2	368	16-1/2	419	13	330	13-3/8	340	7-1/4	185	3-5/8	92	2-5/8	66	2-3/8	60
CX35-18/24B-6F	17-1/2	445	16-1/2	419	16	406	16-3/8	416	7-1/4	185	3-5/8	92	2-5/8	66	2-3/8	60
CX35-30/36A-6F	14-1/2	368	24-1/2	622	13	330	13-3/8	340	13-1/2	343	3-5/8	92	2-5/8	66	2-3/8	60
CX35-30/36B-6F	17-1/2	445	24-1/2	622	16	406	16-3/8	416	13-1/2	343	3-5/8	92	2-5/8	66	2-3/8	60
CX35-30/36C-6F	21	533	24-1/2	622	19-1/2	495	19-7/8	505	13-1/2	343	3-5/8	92	2-5/8	66	2-3/8	60
CX35-36A-6F	14-1/2	368	24-1/2	622	13	330	13-3/8	340	13-1/2	343	3-5/8	92	2-5/8	66	2-3/8	60
CX35-36B-6F	17-1/2	445	24-1/2	622	16	406	16-3/8	416	13-1/2	343	3-5/8	92	2-5/8	66	2-3/8	60

DIMENSIONS - INCHES (MM)

CX35-24(A/B), -30(A/B), -48(B/C), -50/60C and -60D Coils
 (NOTE - See next page for CX35-49C-6F and CX35-60C-6F Coils)

NOTE- CX35-60D coil is positioned in cabinet with coil face running left to right, all other coil sizes are positioned like drawing.

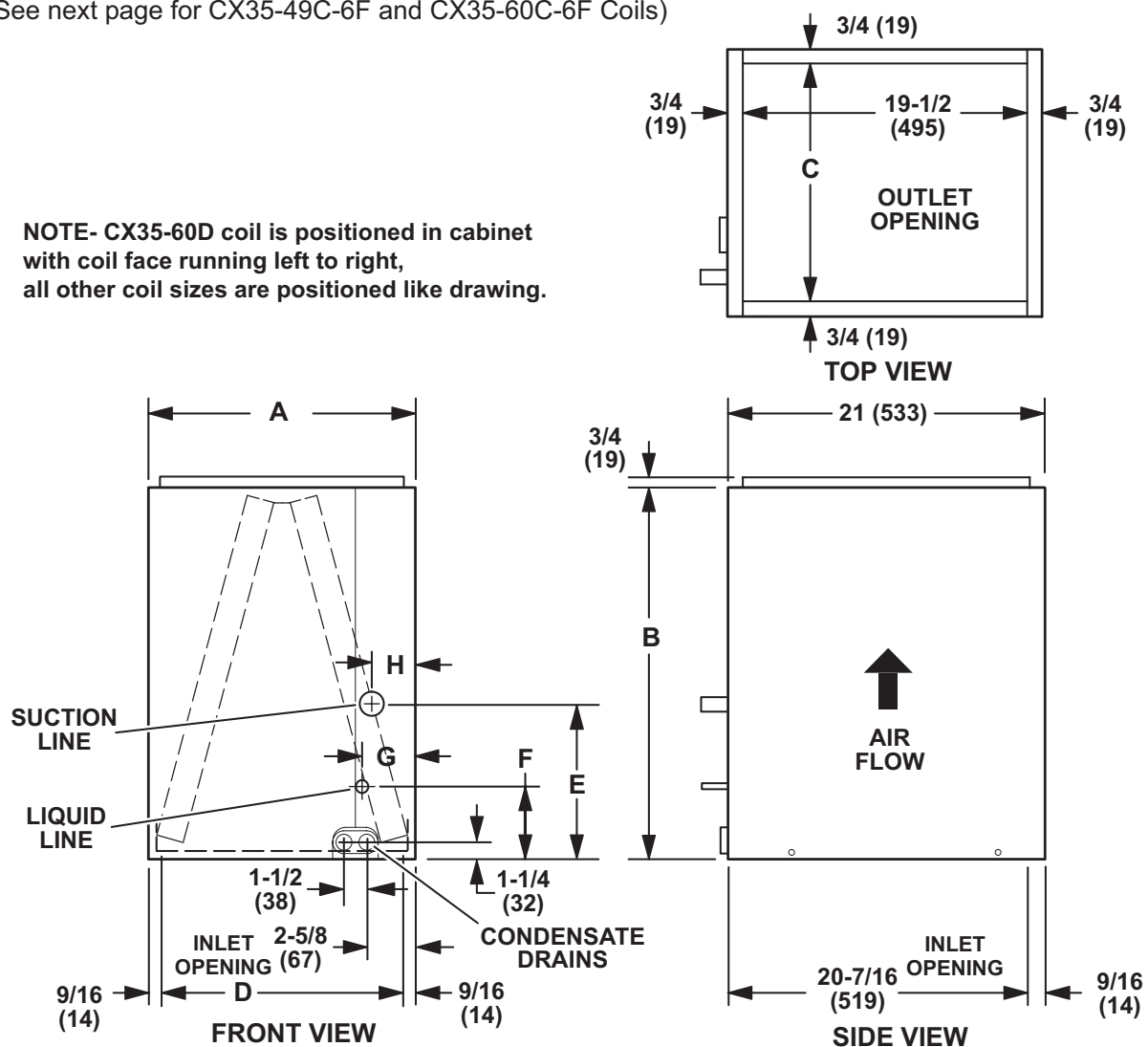

Model Number	A		B		C		D		E		F		G		H	
	in.	mm	in.	mm	in.	mm	in.	mm	in.	mm	in.	mm	in.	mm	in.	mm
CX35-24A-6F	14-1/2	368	18-1/2	470	13	330	13-3/8	340	9-3/4	248	3-5/8	92	2-5/8	66	2-3/8	60
CX35-24B-6F	17-1/2	445	18-1/2	470	16	406	16-3/8	416	9-3/4	248	3-5/8	92	2-5/8	66	2-3/8	60
CX35-30A-6F	14-1/2	368	22-1/2	572	13	330	13-3/8	340	11-1/2	292	3-5/8	92	2-5/8	66	2-3/8	60
CX35-30B-6F	17-1/2	445	22-1/2	572	16	406	16-3/8	416	11-1/2	292	3-5/8	92	2-5/8	66	2-3/8	60
CX35-48B-6F	17-1/2	445	27-1/2	699	16	406	16-3/8	416	12-1/2	318	3-5/8	92	2-5/8	66	2-3/8	60
CX35-48C-6F	21	533	27-1/2	699	19-1/2	495	19-7/8	505	12-1/2	318	3-5/8	92	2-5/8	66	2-3/8	60
CX35-50/60C-6F	21	533	27-1/2	699	19-1/2	495	19-7/8	505	12-1/2	318	3-5/8	92	2-5/8	66	2-3/8	60
CX35-60D-6F	24-1/2	622	29-1/2	749	23	584	23-3/8	594	10	254	3-5/8	92	2-5/8	66	2-3/8	60

DIMENSIONS - INCHES (MM)

CX35-49C-6F and CX35-60C-6F

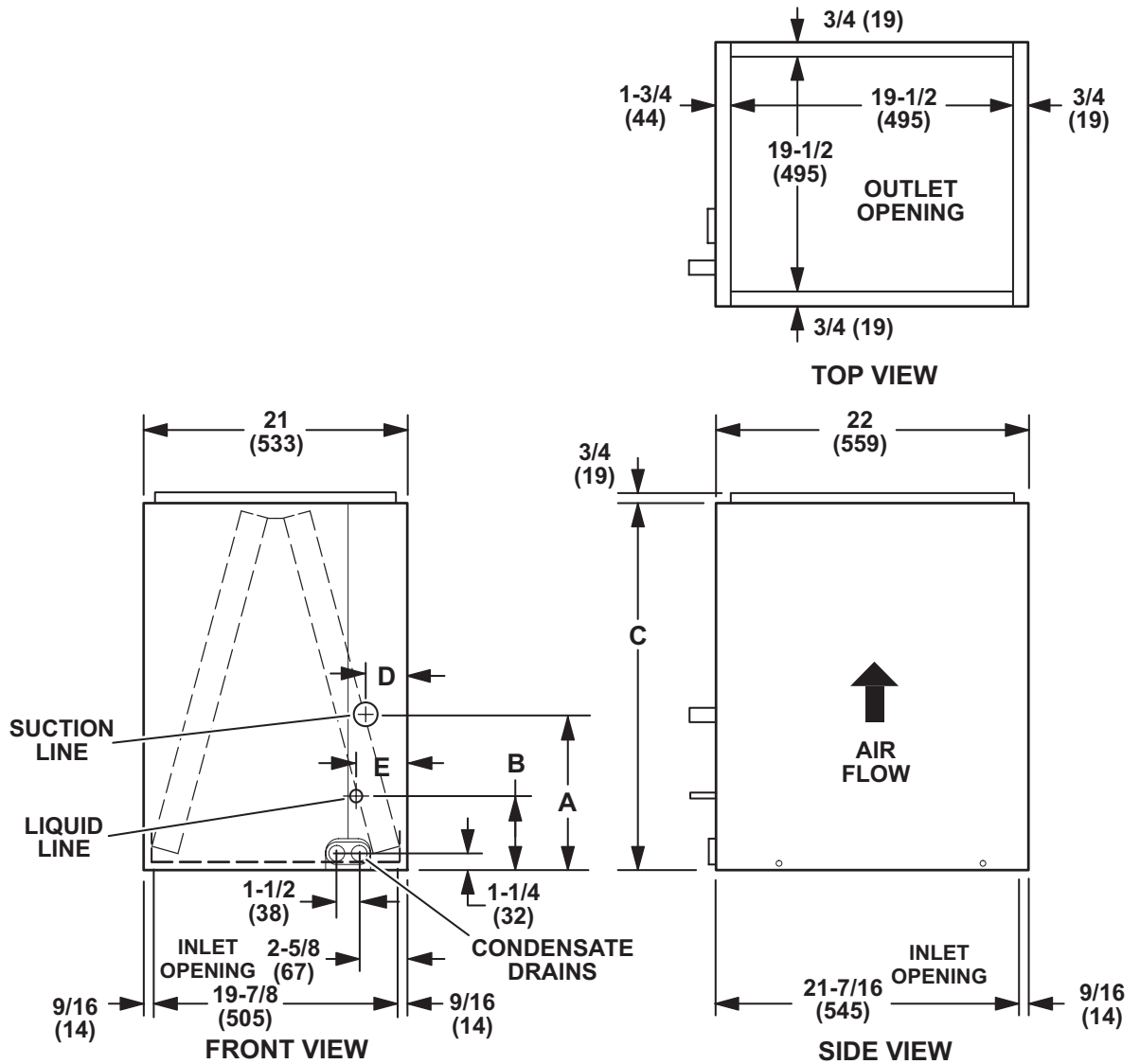

Model Number	A		B		C		D		E	
	in.	mm	in.	mm	in.	mm	in.	mm	in.	mm
CX35-49C-6F	10	254	3-5/8	92	29-1/2	749	2-3/8	60	2-5/8	66
CX35-60C-6F	14-1/2	368	3-5/8	92	31-1/2	800	2-3/8	60	2-5/8	66

CX34 TO CX35 CROSS-REFERENCE

CX34 Model No.	Tons	Dimensions (H x W x D)	Order No.	CX35 Model No.	Tons	Dimensions (H x W x D)	Order No.
CX34-18/24A-6F	1.5 - 2	16.5 x 14.5 x 21	20M63	CX35-18/24A-6F	1.5 - 2	16.5 x 14.5 x 21	10C41
CX34-18/24B-6F	1.5 - 2	16.5 x 17.5 x 21	20M67	CX35-18/24B-6F	1.5 - 2	16.5 x 17.5 x 21	10C42
¹ CX34-18/24C-6F	1.5 - 2	16.5 x 21 x 21	70M27	¹ CX35-18/24B-6F	1.5 - 2	16.5 x 17.5 x 21	10C42
² CX34-19A-6F	1.5	16.5 x 14.5 x 21	85M16	² CX35-24A-6F	2	18.5 x 14.5 x 21	10C43
CX34-25A-6F	2	18.5 x 14.5 x 21	85M17	CX35-24A-6F	2	18.5 x 14.5 x 21	10C43
CX34-25B-6F	2	18.5 x 17.5 x 21	85M18	CX35-24B-6F	2	18.5 x 17.5 x 21	10C44
CX34-31A-6F	2.5	22.5 x 14.5 x 21	85M19	CX35-30A-6F	2.5	22.5 x 14.5 x 21	10C47
CX34-31B-6F	2.5	22.5 x 17.5 x 21	85M20	CX35-30B-6F	2.5	22.5 x 17.5 x 21	10C48
² CX34-30A-6F	2.5	20.5 x 14.5 x 21	20M64	² CX35-30/36A-6F	2.5 - 3	24.5 x 14.5 x 21	10C49
CX34-36A-6F	3	24.5 x 14.5 x 21	20M65	CX35-30/36A-6F	2.5 - 3	24.5 x 14.5 x 21	10C49
² CX34-30B-6F	2.5	20.5 x 17.5 x 21	20M68	² CX35-30/36B-6F	2.5 - 3	24.5 x 17.5 x 21	10C50
CX34-36B-6F	3	24.5 x 17.5 x 21	20M69	CX35-30/36B-6F	2.5 - 3	24.5 x 17.5 x 21	10C50
² CX34-30C-6F	2.5	20.5 x 21 x 21	70M28	² CX35-30/36C-6F	2.5 - 3	24.5 x 21 x 21	10C51
CX34-36C-6F	3	24.5 x 21 x 21	20M74	CX35-30/36C-6F	2.5 - 3	24.5 x 21 x 21	10C51
CX34-38A-6F	3	24.5 x 14.5 x 21	20M66	CX35-36A-6F	3	24.5 x 14.5 x 21	10C52
CX34-38B-6F	3	24.5 x 17.5 x 21	20M70	CX35-36B-6F	3	24.5 x 17.5 x 21	10C53
² CX34-42B-6F	3.5	24.5 x 17.5 x 21	20M71	² CX35-48B-6F	3.5 - 4	27.5 x 17.5 x 21	10C54
CX34-43B-6F	3.5	27.5 x 17.5 x 21	85M21	CX35-48B-6F	3.5 - 4	27.5 x 17.5 x 21	10C54
² CX34-44/48B-6F	4	24.5 x 17.5 x 21	20M72	² CX35-48B-6F	3.5 - 4	27.5 x 17.5 x 21	10C54
CX34-43C-6F	3.5	27.5 x 21 x 21	85M22	CX35-48C-6F	3.5 - 4	27.5 x 21 x 21	10C55
² CX34-44/48C-6F	3.5 - 4	24.5 x 21 x 21	20M75	² CX35-48C-6F	3.5 - 4	27.5 x 21 x 21	10C55
^{2,3} CX34-44/48C-6F	3.5 - 4	24.5 x 21 x 21	20M75	^{2,3} CX35-49C-6F	4	29.5 x 21 x 22	10C56
CX34-49C-6F	4	29.5 x 21 x 22	85M23	CX35-49C-6F	4	29.5 x 21 x 22	10C56
CX34-50/60C-6F	4 - 5	27.5 x 21 x 21	20M76	CX35-50/60C-6F	4 - 5	27.5 x 21 x 21	10C57
CX34-62C-6F	5	31.5 x 21 x 22	85M24	CX35-60C-6F	5	31.5 x 21 x 22	10C58
² CX34-60D-6F	5	25.5 x 24.5 x 21	20M77	² CX35-60D-6F	5	29.5 x 24.5 x 21	10C59
CX34-62D-6F	5	29.5 x 24.5 x 21	20M78	CX35-60D-6F	5	29.5 x 24.5 x 21	10C59

¹ Coil **widths** do not match between CX34 and CX35 models.

² Coil **heights** do not match between CX34 and CX35 models.

³ Coil **depths** do not match between CX34 and CX35 models.

REVISIONS

Sections	Description of Change
Dimensions	Plumbing dimensions updated due to move to new manufacturing facility.



Visit us at www.lennox.com

For the latest technical information, www.LennoxPROs.com

Contact us at 1-800-4-LENNOX

NOTE - Due to Lennox' ongoing commitment to quality, Specifications, Ratings and Dimensions subject to change without notice and without incurring liability. Improper installation, adjustment, alteration, service or maintenance can cause property damage or personal injury. Installation and service must be performed by a qualified installer and servicing agency.

©2018 Lennox Industries, Inc.