



EL16XP1

ELITE® Series
R-410A - 60 Hz

RESIDENTIAL
PRODUCT SPECIFICATIONS

Bulletin No. 210880
 October 2020
 Supersedes April 2019

ELITE®
 SERIES



SEER up to 17.00
HSPF up to 9.80
1.5 to 5 Tons

Cooling Capacity - 18,000 to 58,500 Btuh
Heating Capacity - 16,900 to 56,000 Btuh

MODEL NUMBER IDENTIFICATION

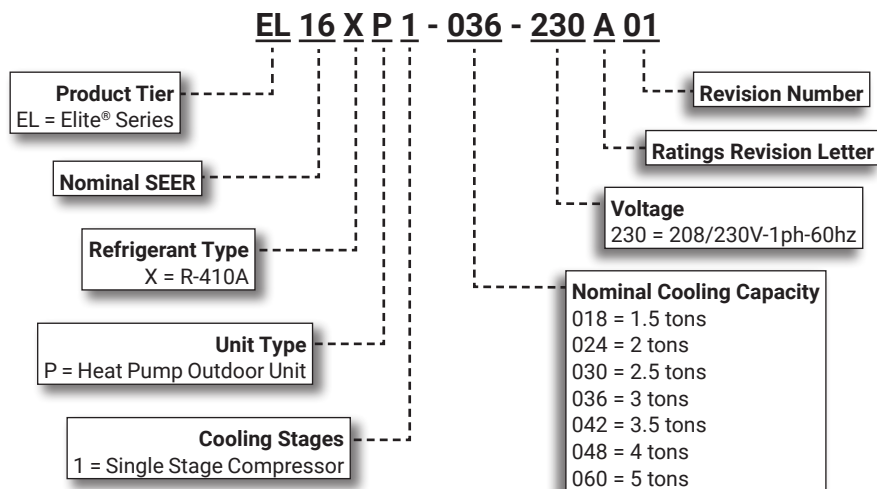

FEATURE HIGHLIGHTS

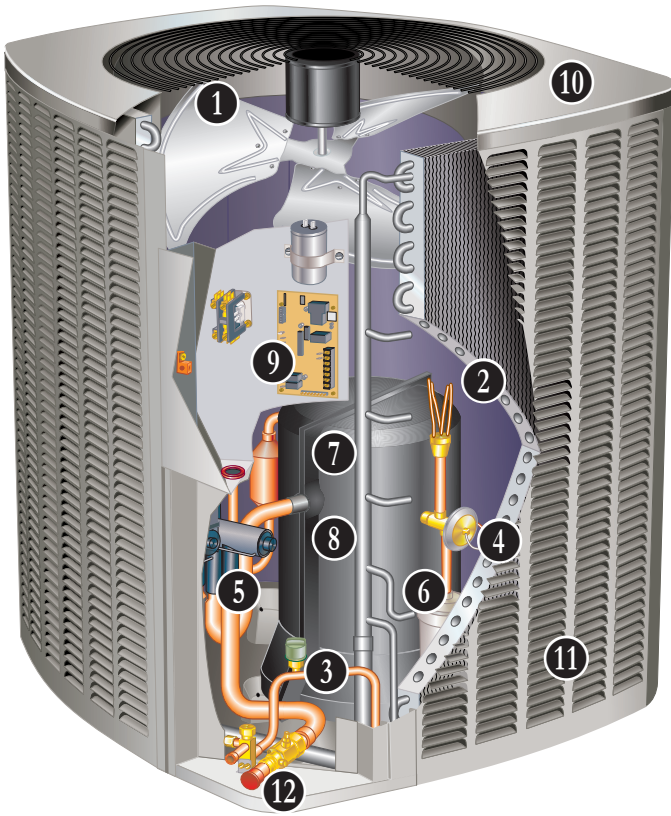

1. Outdoor Coil Fan
2. Quantum™ Coil
3. High Pressure Switch
4. Expansion Valve - Outdoor Unit
5. Four-Way Reversing Valve
6. High-Capacity Liquid Line Drier
7. Scroll Compressor
8. Compressor Sound Dampening System
9. Defrost Control
10. Heavy Gauge Steel Cabinet
11. SmartHinge™ Louvered Coil Protection
12. Refrigerant Line Connections

CONTENTS

Approvals And Warranty	3
Controls	8
Dimensions	11
Electrical Data	8
Features	3
Field Wiring	10
Installation Clearances	10
Model Number Identification	1
Optional Accessories - Order Separately	8
Sound Data	10
Specifications	8
TXV Substitution	12
TXV Usage	12

APPROVALS AND WARRANTY

APPROVALS

- AHRI Certified to AHRI Standard 210/240
- For AHRI Certified system match-ups and expanded ratings, visit www.LennoxPros.com
- ENERGY STAR® certified
- Sound rated to AHRI Standard 270-2008 test conditions
- Tested in the Lennox Research Laboratory environmental test room
- Rated According to U.S. Department of Energy (DOE) test procedures
- Units and components UL, NEC, and CEC bonded for grounding to meet safety standards for servicing
- ETL certified (U.S. and Canada)
- ISO 9001 Registered Manufacturing Quality System

WARRANTY

- Compressor:
 - Limited ten years in residential installations
 - Limited five years in non-residential installations
- All other covered components:
 - Limited five years in residential installations
 - Limited one year in non-residential installations

NOTE - Refer to Lennox Equipment Limited Warranty certificate included with unit for specific details.

FEATURES

APPLICATIONS

- 1.5 through 5 tons
- Sound levels as low as 71 dBA
- Single phase power supply
- Vertical air discharge
- Applicable to indoor air handlers or gas furnaces with indoor add-on coils
- Shipped completely factory assembled, piped and wired
- Factory test operated

NOTE - When heat pumps are used with gas furnaces, a dual-fuel compatible thermostat or a zone control system with dual-fuel capabilities must be used (order separately)

NOTE - Installer must set outdoor unit, connect refrigerant lines and make electrical connections to complete job

REFRIGERATION SYSTEM

R-410A Refrigerant

- Non-chlorine, ozone friendly
- Unit is factory pre-charged

NOTE - Total system refrigerant charge is dependant on outdoor unit size, indoor unit size and refrigerant line length.

NOTE - Refer to the unit-mounted charging sticker to determine correct amount of charge required.

① Outdoor Coil Fan

- Direct drive fan
- EL16XP1-036-042-048-060 models have a variable-speed outdoor fan motor for quiet operation
- Vertical air discharge
- Ball bearings
- Inherently protected
- Totally enclosed fan motor
- Fan guard constructed of corrosion-resistant PVC (polyvinyl chloride) coated steel

② Quantum™ Coil

- Lennox designed and fabricated coil
- Enhanced aluminum alloy tube/enhanced fin coil
- Ripple-edged aluminum fins
- Aluminum tube construction
- Lanced fins for maximum fin surface exposure
- Fin collars grip tubing for maximum contact area
- Flared shoulder tubing connections
- Factory tested under high pressure
- Entire coil is accessible for cleaning

FEATURES

REFRIGERATION SYSTEM (continued)

3 High Pressure Switch

- Protects the system from high pressure conditions that can be a result of fan failure or a blocked/dirty coil
- Automatic reset

Low Pressure Switch

- Shuts off unit if suction pressure falls below setting
- Provides loss of charge and freeze-up protection
- Automatic reset

4 Expansion Valve - Outdoor Unit

- Designed and sized for heat pump systems
- Sensing bulb senses evaporator suction temperature during heating cycle

5 Four-Way Reversing Valve

- Rapid changeover of refrigerant flow direction from cooling to heating and vice versa
- Operates on pressure differential between outdoor unit and indoor unit of the system
- Factory installed

6 High-Capacity Liquid Line Drier

- Factory installed in the liquid line
- Drier traps moisture or dirt
- 100% molecular-sieve, bead type, bi-flow drier

Optional Accessories

Check/Expansion Valve Kits

- Field installed on certain indoor units
- See TXV Usage table
- Chatleff style fitting

Loss of Charge Kit

- Helps protect the compressor from damage due low refrigerant charge conditions
- SPST, normally-closed switch, automatic reset switch

Freezestat

- Installs on or near the vapor line of the indoor coil or on the suction line
- Senses suction line temperature
- Cycles compressor off when suction line temperature falls below it's setpoint
- Opens at 29°F and closes at 58°F
- Installs on or near the discharge line of the evaporator or on the suction line

Refrigerant Line Kits

- Refrigerant lines are shipped refrigeration clean
- Lines are cleaned, dried, pressurized and sealed at factory
- Suction line fully insulated
- Lines are stubbed at both ends

NOTE - Not available for -060 models and must be field fabricated

FEATURES

COMPRESSOR

7 Scroll Compressor

- High efficiency with uniform suction flow
- Constant discharge flow, high volumetric efficiency and quiet operation
- Low gas pulses during compression reduces operational sound levels
- Compressor motor is internally protected from excessive current and temperature
- Muffler in discharge line reduces operating sound levels
- Compressor is installed in the unit on resilient rubber mounts for vibration free operation



Scroll Compressor Operation

- Two involute spiral scrolls matched together generate a series of crescent-shaped gas pockets between them
- During compression, one scroll remains stationary while the other scroll orbits around it
- Gas is drawn into the outer pocket, the pocket is sealed as the scroll rotates
- As the spiral movement continues, gas pockets are pushed to the center of the scrolls. Volume between the pockets is simultaneously reduced
- When the pocket reaches the center, gas is now at high pressure and is forced out of a port located in the center of the fixed scrolls
- During compression, several pockets are compressed simultaneously resulting in a smooth continuous compression cycle
- Continuous flank contact, maintained by centrifugal force, minimizes gas leakage and maximizes efficiency
- Compressor is tolerant to the effects of slugging and contaminants. If this occurs, scrolls separate, allowing liquid or contaminants to be worked toward the center and discharged

Compressor Crankcase Heater (Factory Installed on -036-042-048-060)

- Protects against refrigerant migration that can occur during low ambient operation

8 Compressor Sound Dampening System

- Polyethylene compressor cover
- 2-inch thick batt of fiberglass insulation
- Hook and loop fastening tape on all open edges

Optional Accessories

Compressor Crankcase Heater (Optional for -018-024-030 models)

- Protects against refrigerant migration that can occur during low ambient operation

CONTROLS

9 Defrost Control

- Control furnished as standard
- Gives a demand defrost cycle whenever system heating performance falls below optimum levels. The sensing element on coil determines when defrost cycle is required and when to terminate cycle
- Anti-short cycle (5 minutes) incorporated into the board
- Diagnostic LEDs furnished as an aid in troubleshooting
- Conveniently located in control box

Optional Accessories

Compressor Low Ambient Cut-Off

- Non-adjustable switch (low ambient cut-out) prevents compressor operation when outdoor temperature is below 35°F

Compressor Hard Start Kit

- Single-phase units are equipped with a PSC compressor motor
- This type of motor normally does not need a potential relay and start capacitor
- In conditions such as low voltage, kit may be required to increase the compressor starting torque

Indoor Blower Off Delay Relay

- Delays the indoor blower-off time during the cooling cycle. See AHRI System Matches for usage

Low Ambient Kit

- Heat pump in the cooling mode will operate satisfactorily down to 45°F outdoor air temperature without any additional controls
- Allows unit to operate properly down to 30°F in the cooling mode

NOTE - Crankcase heater (optional for -018-024-030 models) and Freezestat should be installed on compressors equipped with a low ambient kit.

NOTE - A compressor lock-out thermostat should be added to terminate compressor operation below recommended operation conditions.

Monitor Kit - Service Light

- Ambient compensating thermistor
- Service light thermostat
- For thermostats requiring indicator light inputs

FEATURES

CONTROLS (continued)

Optional Accessories (continued)

iComfort® E30 Smart Wi-Fi Thermostat

- Wi-Fi enabled, electronic 7-day, universal, multi-stage, programmable, touchscreen thermostat
- 3 Heat/2 Cool
- Auto-changeover
- Controls dehumidification during cooling mode and humidification during heating mode
- Offers enhanced capabilities including humidification / dehumidification / dewpoint measurement and control, Humiditrol® control, and equipment maintenance reminders
- Easy to read 7 in. color touchscreen (measured diagonally)
- LCD display with backlight shows the current and set temperature, time, inside relative humidity, system status (operating mode and schedules) and outside temperature (optional outdoor sensor required)
- Smooth Setback Recovery starts system early to achieve setpoint at start of program period
- Compressor short-cycle protection (5 minutes)
- Up to four separate schedules are available plus Schedule IQ™
- One-Touch Away Mode - A quick and easy way to set the cooling and heating setpoints while away
- Smart Away™ - Uses geo-fencing technology to determine when the homeowner is within a predetermined distance from the home to operate the system when leaving, away and arriving
- Wi-Fi remote monitoring and adjustment through a home wireless network for desktop PCs, laptops and apps for smartphones or tablets
- Smart home automation compatible with Apple HomeKit™, Amazon Alexa®, Google Assistant and IFTTT
- Service Dashboard features online real-time monitoring of installed iComfort® thermostats
- High Definition Color Display with Subbase, Smart Hub Controller, wallplate (for retrofit installations) furnished for easy installation
- See the iComfort® E30 Smart Wi-Fi Thermostat Product Specifications bulletin for more information



Remote Outdoor Temperature Sensor

- Used with the iComfort® E30 Smart Thermostat
- When installed outdoors, sensor allows thermostat to display outdoor temperature
- Sensor is auto-detected when connected to thermostat



NOTE - Sensor is required for high and low balance points option.

NOTE - Sensor is required for Enhanced Dehumidification Accessory (EDA).

Thermostat

- Thermostat is not furnished with unit
- See Lennox Price Book for selection

Mild Weather Kit

- Heat pump units operate satisfactorily in the heating mode at outdoor air temperatures up to 75°F
- Allows heating operation above 75°F

Outdoor Thermostat Kit

- Outdoor thermostat locks out some of the electric heating elements on indoor units where two-stage control is applicable
- Outdoor thermostat maintains the heating load on the low power input as long as possible before allowing the full power load to come on the line
- Thermostat kit and Mounting Box must be ordered separately

FEATURES

10 CABINET

- Heavy-gauge steel construction
- Pre-painted cabinet finish
- Control box is conveniently located with all controls factory wired
- Corner patch plate allows compressor access
- Drainage holes are provided in base section for moisture removal
- Drainage holes are provided in base section
- High density polyethylene unit support feet raise the unit off of the mounting surface

PermaGuard™ Unit Base

- Durable zinc-coated base section resists rust and corrosion

11 SmartHinge™ Louvered Coil Protection

- Steel louvered panels provides complete coil protection
- Panels are hinged to allow easy cleaning and servicing of coils. Panels may be completely removed
- Interlocking tabs and slots assure tight fit on cabinet



Refrigerant Line Connections, Electrical Inlets and Service Valves

- 12 • Sweat connection vapor and liquid lines
- Vapor valve can be fully shut off, while liquid valve may be front seated to manage refrigerant charge while servicing system
- Refrigerant line connections and field wiring inlets are located in one central area of the cabinet
- See dimension drawing

Optional Accessories

Snow Guard

- For use in locations where the possibility of heavy snow or freezing rain accumulation may occur
- Heavy gauge powder coated steel guard
- Deflects snow and ice away from the outdoor fan

NOTE - Snow Guards for 018-024-030 models are only available in Canada.

SPECIFICATIONS

General Data		Model No.	EL16XP1-018	EL16XP1-024	EL16XP1-030	EL16XP1-036
		Nominal Tonnage	1.5	2	2.5	3
¹ Sound Rating Number (dBA)			71	72	72	72
Connections (sweat)	Liquid line (o.d.) - in.		3/8	3/8	3/8	3/8
	Suction line (o.d.) - in.		3/4	3/4	3/4	7/8
Refrigerant	² R-410A charge furnished		6 lbs. 6 oz.	6 lbs. 11 oz.	7 lbs. 10 oz.	8 lbs. 7 oz.
Outdoor Coil	Net face area - sq. ft.	Outer coil	24.5	18.7	18.7	22.2
		Inner coil	- - -	18.0	18.0	21.5
	Tube diameter - in.		5/16	5/16	5/16	5/16
	No. of rows		1	2	2	2
	Fins per inch		22	22	22	22
	Diameter - in.		22	22	22	26
Outdoor Fan	No. of blades		3	3	3	3
	Motor hp		1/6	1/6	1/6	1/3
	Cfm		2670	2575	2575	3700
	Rpm		867	866	866	820
	Watts		160	163	163	200
	Shipping Data - lbs. 1 pkg.			213	211	211

ELECTRICAL DATA

Line voltage data - 60hz	208/230V-1ph	208/230V-1ph	208/230V-1ph	208/230V-1ph
³ Maximum overcurrent protection (amps)	20	20	25	35
⁴ Minimum circuit ampacity	12.2	13.6	16.4	20.9
Compressor	Rated load amps	9	10.1	12.3
	Locked rotor amps	48	52	63
	Power factor	0.98	0.98	0.96
Outdoor Fan Motor	Full load amps	1.0	1.0	1.0
	Locked rotor amps	1.9	1.9	1.9

CONTROLS

iComfort® E30 Smart Wi-Fi Thermostat	20A65	•	•	•	•
Remote Outdoor Temperature Sensor	X2658	•	•	•	•

OPTIONAL ACCESSORIES - ORDER SEPARATELY

Compressor Crankcase Heater	93M04	•	•	•	
	Factory				•
Compressor Hard Start Kit	LG 88M91	•	•	•	•
Compressor Low Ambient Cut-Off	45F08	•	•	•	•
Freezestat	3/8 in. tubing 93G35	•	•	•	•
	5/8 in. tubing 50A93	•	•	•	•
Indoor Blower Off Delay Relay	58M81	•	•	•	•
Loss of Charge Switch Kit	84M23	•	•	•	•
⁵ Low Ambient Kit	54M89	•	•	•	•
Mild Weather Kit	11B97	•	•	•	•
Monitor Kit - Service Light	76F53	•	•	•	•
Outdoor Thermostat Kit	Thermostat 10Z23	•	•	•	•
	Mounting Box 31461	•	•	•	•
Refrigerant Line Sets	L15-41-20 L15-41-40	•	•	•	
	L15-41-30 L15-41-50				
⁶ Snow Guard	35-1/2 x 31 in. (Canada Only) X8780	•	•	•	

NOTE - Extremes of operating range are plus 10% and minus 5% of line voltage.

¹ Sound Rating Number rated in accordance with test conditions included in AHRI Standard 270.

² Refrigerant charge sufficient for 15 ft. length of refrigerant lines. For longer line set requirements see the Installation Instructions for information about line set length and additional refrigerant charge required.

³ HACR type breaker or fuse.

⁴ Refer to National or Canadian Electrical Code manual to determine wire, fuse and disconnect size requirements.

⁵ Crankcase Heater and Freezestat are recommended with Low Ambient Kit.

⁶ Add 11-1/2 inches (292 mm) to unit height.

SPECIFICATIONS

General Data		Model No.	EL16XP1-042	EL16XP1-048	EL16XP1-060
		Nominal Tonnage	3.5	4	5
¹ Sound Rating Number (dBA)			73	73	73
Connections (sweat)	Liquid line (o.d.) - in.		3/8	3/8	3/8
	Suction line (o.d.) - in.		7/8	7/8	1-1/8
Refrigerant	² R-410A charge furnished		10 lbs. 12 oz.	10 lbs. 7 oz.	10 lbs. 4 oz.
Outdoor Coil	Net face area - sq. ft.	Outer coil	29.1	29.1	29.1
		Inner coil	28.2	28.2	28.2
	Tube diameter - in.	5/16	5/16	5/16	
	No. of rows	2	2	2	
	Fins per inch	22	22	22	
Outdoor Fan	Diameter - in.		26	26	26
	No. of blades		3	3	4
	Motor hp		1/3	1/3	1/3
	Cfm		4150	4150	4250
	Rpm		820	820	820
	Watts		216	216	245
	Shipping Data - lbs. 1 pkg.			294	294

ELECTRICAL DATA

Line voltage data - 60hz	208/230V-1ph	208/230V-1ph	208/230V-1ph	
³ Maximum overcurrent protection (amps)	40	40	50	
⁴ Minimum circuit ampacity	25	25.8	30.4	
Compressor	Rated load amps	15.9	18.5	22.2
	Locked rotor amps	112.3	124	127.9
	Power factor	0.99	0.99	0.99
Outdoor Fan Motor	Full load amps	2.6	2.6	2.6

CONTROLS

iComfort® E30 Smart Wi-Fi Thermostat	20A65	•	•	•
Remote Outdoor Temperature Sensor	X2658	•	•	•

OPTIONAL ACCESSORIES - ORDER SEPARATELY

Compressor Hard Start Kit	Copeland	10J42	•	•	•
	LG	88M91	•		•
Compressor Low Ambient Cut-Off		45F08	•	•	•
Freezestat	3/8 in. tubing	93G35	•	•	•
	5/8 in. tubing	50A93	•	•	•
Indoor Blower Off Delay Relay		58M81	•	•	•
Loss of Charge Switch Kit		84M23	•	•	•
⁵ Low Ambient Kit		54M89	•	•	•
Mild Weather Kit		11B97	•	•	•
Monitor Kit - Service Light		76F53	•	•	•
Outdoor Thermostat Kit	Thermostat	10Z23	•	•	•
	Mounting Box	31461	•	•	•
Refrigerant Line Sets	L15-65-30	L15-65-40	•	•	
		L15-65-50			
⁶ Snow Guard	39-1/2 x 35-5/8 in.	Y1033	•	•	•

NOTE - Extremes of operating range are plus 10% and minus 5% of line voltage.

¹ Sound Rating Number rated in accordance with test conditions included in AHRI Standard 270.

² Refrigerant charge sufficient for 15 ft. length of refrigerant lines. For longer line set requirements see the Installation Instructions for information about line set length and additional refrigerant charge required.

³ HACR type breaker or fuse.

⁴ Refer to National or Canadian Electrical Code manual to determine wire, fuse and disconnect size requirements.

⁵ Crankcase Heater and Freezestat are recommended with Low Ambient Kit.

⁶ Add 11-1/2 inches (292 mm) to unit height.

SOUND DATA

¹ Unit Model	Octave Band Sound Power Levels dBA, re 10 ⁻¹² Watts Center Frequency - HZ							¹ Sound Rating Number (dBA)	² Estimated Sound Pressure Level at Distance From Unit (dBA at distance in ft.)				
	125	250	500	1000	2000	4000	8000		3	5	10	15	50
018	56.5	62	65.5	66.5	62.5	59.5	52	71	64	59	53	50	39
024	54.5	62	67.5	67.5	63	58	50.5	72	65	60	54	51	40
030	54.5	62	67.5	67.5	63	58	50.5	72	65	60	54	51	40
036	56	61	66.5	65.0	62	57	49	72	65	60	54	51	40
042	57	62.5	68.5	67.5	65	59	50.5	73	66	61	55	52	41
048	57	62.5	68.5	67.5	65	59	50.5	73	66	61	55	52	41
060	54.5	60.5	66.5	68	65	61	56	73	66	61	55	52	41

NOTE - the octave sound power data does not include tonal correction.

¹ Tested according to AHRI Standard 270-2008 test conditions.

² Estimated sound pressure level at distance based on AHRI Standard 275-2010 method for equipment located on the ground, roof, or on side of building wall with no adjacent reflective surface within 9.8 feet. Sound pressure levels will increase based on changes to assumptions. For other applications, refer to AHRI Standard 275.

FIELD WIRING

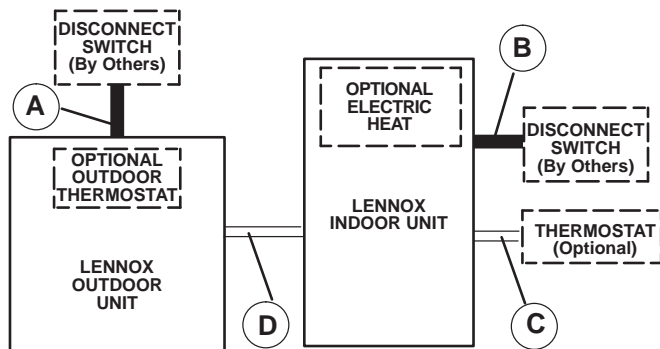

A - Two Wire Power (see Electrical Data)

B - Two or Three Wire Power (size to heater capacity)

C - Twelve Wire Low Voltage 18 ga. minimum
Fourteen Wire Low Voltage with Optional Outdoor Thermostat

D - Eight Wire Low Voltage 18 ga. minimum
Ten Wire Low Voltage with Optional Outdoor Thermostat

NOTE - Field Wiring Not Furnished

All wiring must conform to NEC or CEC and local electrical codes.

INSTALLATION CLEARANCES

NOTES:

Service clearance of 30 in. (762 mm) must be maintained on one of the sides adjacent to the control box.

Clearance to one of the other three sides must be 36 in. (914 mm)

Clearance to one of the remaining two sides may be 12 in. (305 mm) and the final side may be 6 in. (152 mm).

A clearance of 24 in. (610 mm) must be maintained between two units.

48 in. (1219 mm) clearance required on top of unit.

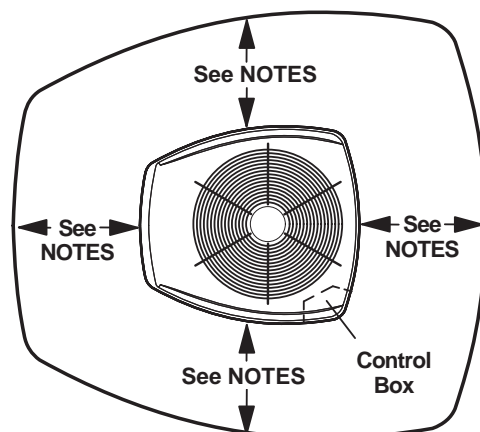

DIMENSIONS

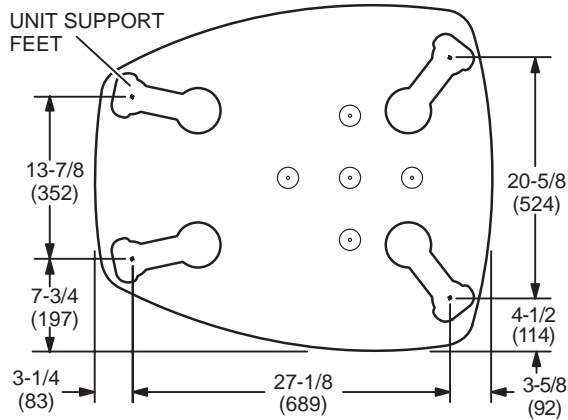
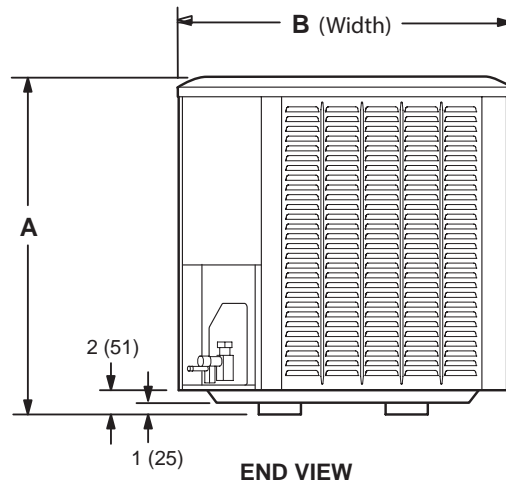
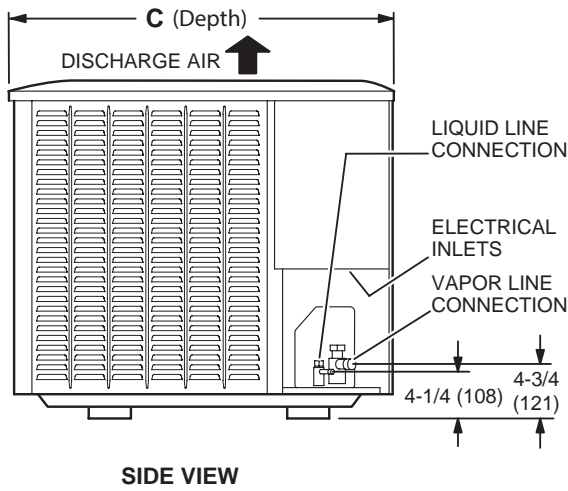
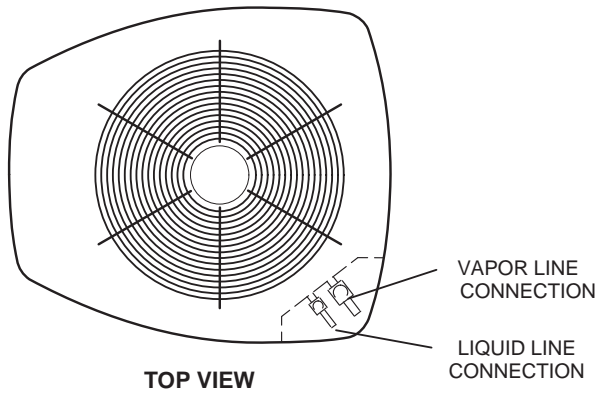

**EL16XP1-018 TO -030 BASE SECTION
(Medium Base)**

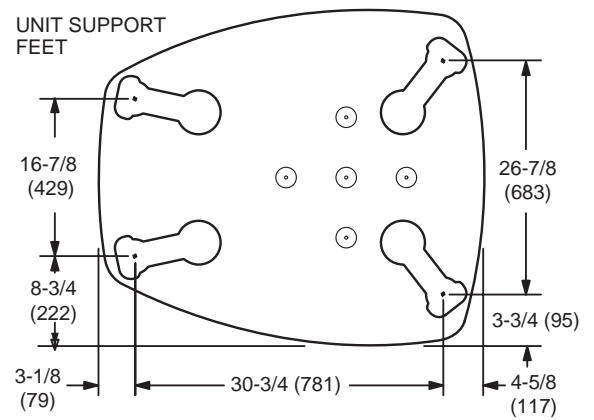

**EL16XP1-036 TO -060 BASE SECTION
(Large Base)**

Model No.	A		B		C	
	in.	mm	in.	mm	in.	mm
EL16XP1-018	45	1143	30-1/2	775	35	889
EL16XP1-024	35	889	30-1/2	775	35	889
EL16XP1-030	35	889	30-1/2	775	35	889
EL16XP1-036	35	889	35-1/2	902	39-1/2	1003
EL16XP1-042	45	1143	35-1/2	902	39-1/2	1003
EL16XP1-048	45	1143	35-1/2	902	39-1/2	1003
EL16XP1-060	45	1143	35-1/2	902	39-1/2	1003

TXV USAGE

Use this table for C35, CH23, CH35 and CR33 Field Installed TXV Match-Ups

Model No.	Order No.
EL16XP1-018	12J18
EL16XP1-024	12J18
EL16XP1-030	12J18
EL16XP1-036	12J19
EL16XP1-042	12J20
EL16XP1-048	12J20
EL16XP1-060	12J20

CX35 and CHX35 coils and all Lennox air handlers are shipped with a factory installed TXV.

C35 and CH35 coils - Replace the factory installed RFC orifice with the expansion valve listed.

CH23 and CR33 - Use the expansion valve listed.

MOST POPULAR MATCHES

Outdoor Unit Model No.	Indoor Unit Model No
EL16XP1-018	CBA27UHE-018
EL16XP1-024	CBA27UHE-024
EL16XP1-030	CBA27UHE-030
EL16XP1-036	CBA27UHE-036
EL16XP1-042	CBA27UHE-048
EL16XP1-048	CBA27UHE-048
EL16XP1-060	CBA27UHE-060

AHRI STANDARD 210/240

Cooling or heating capacities are net values, including the effects of blower motor heat, and do not include supplementary heat. Power input is the total power input to the compressor(s) and fan(s), plus any controls and other items required as part of the system for normal operation.

Units which do not have an indoor air-circulating blower furnished as part of the model, i.e., split system with indoor coil only, is established by subtracting from the total cooling capacity 1250 Btu/h per 1,000 cfm, and by adding the same amount to the heating capacity. Total power input for both heating and cooling is increased by 365 W per 1,000 cfm of indoor air circulated.

TXV SUBSTITUTION

A general guide for replacing the factory installed TXV if the indoor unit (coil/air handler) is larger or smaller than the outdoor unit.

Outdoor Unit		Indoor Unit		TXV	TXV
Size	Tons	Size	Tons	Furnished	Replacement
018	1.5	30/36	2.5/3	12J19	12J18
018	1.5	36	3	12J19	12J18
018	1.5	42	3.5	12J20	12J18
018	1.5	48	4	12J20	12J18
018	1.5	49	4	12J20	12J18
018	1.5	50/60	4/5	12J20	12J18
018	1.5	51/61	4/5	12J20	12J18
018	1.5	60	5	12J20	12J18
024	2	42	3.5	12J20	12J18
024	2	48	4	12J20	12J18
024	2	49	4	12J20	12J18
024	2	50/60	5	12J20	12J18
024	2	51/61	5	12J20	12J18
024	2	60	5	12J20	12J18
030	2.5	42	3.5	12J20	12J18
030	2.5	43	3.5	12J20	12J18
030	2.5	48	4	12J20	12J18
030	2.5	49	4	12J20	12J18
036	3	24	2	12J18	12J19
036	3	30	2.5	12J18	12J19
042	3.5	24	2	12J18	12J20
042	3.5	30	2.5	12J18	12J20
042	3.5	30/36	3	12J19	12J20
042	3.5	36	3	12J19	12J20
048	4	30/36	2.5/3	12J19	12J20
048	4	36	3	12J19	12J20

TXV Ranges:

12J18 - 1.5 to 2.5 ton systems - Use on 2.5 ton (030) and lower systems.

12J19 - 3 ton systems - Use down to 2 ton (024) systems.

12J20 - 3.5 to 5 ton systems - Use down to 3 ton (036) systems.

REVISIONS

Sections	Description of Change
Optional Accessories	Updated.
TXV Substitutions	Updated.



Visit us at www.Lennox.com

For the latest technical information, www.LennoxPros.com

Contact us at 1-800-4-LENNOX

NOTE - Due to Lennox' ongoing commitment to quality, Specifications, Ratings and Dimensions subject to change without notice and without incurring liability. Improper installation, adjustment, alteration, service or maintenance can cause property damage or personal injury. Installation and service must be performed by a qualified installer and servicing agency.

©2020 Lennox Industries, Inc.