



GAS FURNACES

EL180UHNE

ELITE® SERIES

Upflow / Horizontal - Constant Torque Blower Motor - 60 Hz

**RESIDENTIAL
PRODUCT SPECIFICATIONS**

Bulletin No. 210801
November 2020
Supersedes July 2020

**ELITE®
SERIES**



AFUE - 80%
Meets NOx Limit of 14 ng/J
Input - 40,000 to 100,000 Btuh
Nominal Add-on Cooling - 1.5 to 5 Tons

MODEL NUMBER IDENTIFICATION

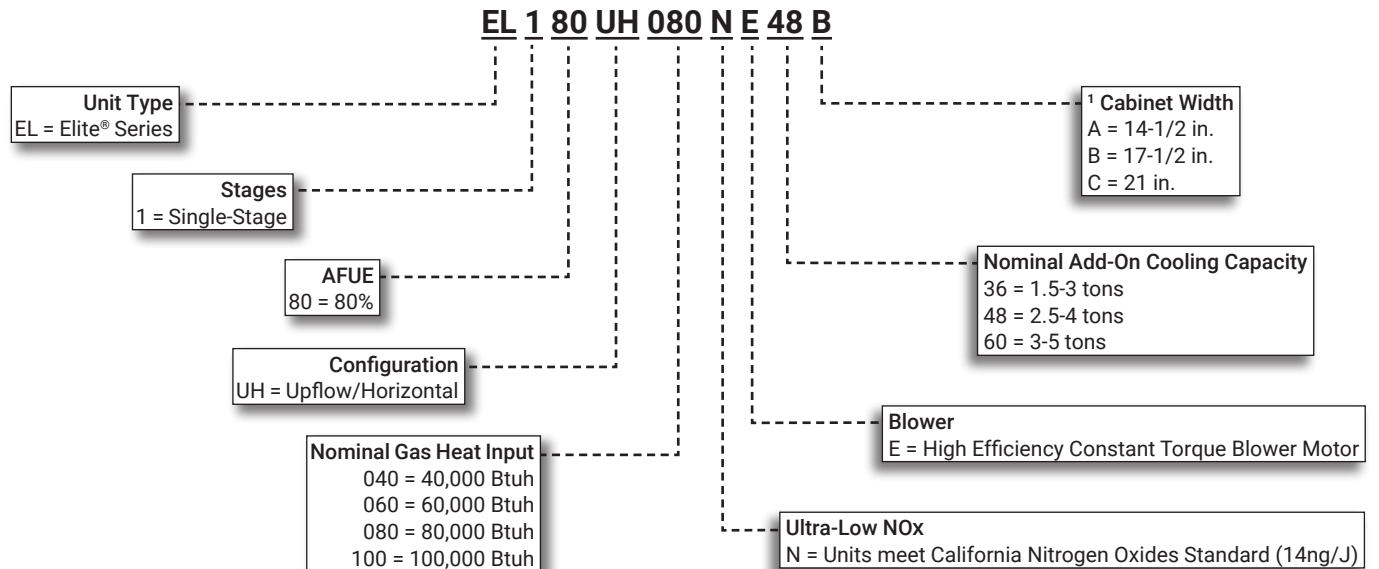

¹ Indoor coils with the same letter designation will physically match the furnace.

CONTENTS

Blower Data	13
Approvals And Warranty	3
Dimensions	9
- Unit - Upflow Position	9
- Unit - Horizontal Position	10
- Optional Accessories	11
- Furnace/Coil Combined Dimensions	12
Features	3
Gas Heat Accessories	8
High Altitude Operation.	7
Installation Clearances	7
Model Number Identification.	1
Optional Accessories - Order Separately	8
Specifications	8

NOTE - EL180UHNE FURNACES ARE NOT AVAILABLE IN CANADA!
NOTE - EL180UHNE 40K and 100K FURNACES ARE NATURAL GAS ONLY!
NOTE - NOT AVAILABLE IN ALL AREAS!
CONTACT YOUR NEAREST LENNOX SALES OFFICE FOR DETAILS.

APPROVALS AND WARRANTY

APPROVALS

- AHRI Certified
- Tested and rated according to US DOE test procedures and FTC labeling regulations
- Approved by the California Energy Commission and meets California Nitrogen Oxides Standard (NOx) limits of 14 ng/J
- ISO 9001 Registered Manufacturing Quality System
- Blower data from unit tests conducted in Lennox Laboratory air test chamber

California Only

- These furnaces meet the South Coast Air Quality Management District (SCAQMD) Rule 1111 and San Joaquin Valley Air Pollution Control District (SJVAPCD) Rule 4905 NOx emission limit (14 ng/J) and can be installed within the SCAQMD and SJVAPCD areas

WARRANTY

- Heat Exchanger:
 - Limited twenty years in residential applications
 - Limited ten years in non-residential applications
- All other covered components:
 - Limited five years in residential installations
 - Limited one year in non-residential installations

NOTE - Refer to Lennox Equipment Limited Warranty certificate included with unit for specific details.

FEATURES

APPLICATIONS

- Input capacities of 44,000, 66,000, 88,000, 110,000 and 132,000 Btuh
- Energy efficiency (AFUE) - 80%
- Compact cabinet for upflow, horizontal-left or horizontal-right applications
- Utility room, alcove, closet, crawl space, basement or attic installation
- Lennox add-on indoor coils, high-efficiency air cleaners and humidifiers can easily be added to furnace
- Shipped factory assembled with all controls installed and wired
- Ready for installation in upflow or horizontal position without any modifications
- Removable bottom seal panel shipped in place for side return air is easily removed for bottom/end return air applications
- Each unit factory test operated to ensure proper operation

HEATING SYSTEM

NOTE - Units Are Natural Gas Only!

Heat Exchanger Assembly

- Heavy gauge aluminized steel heat exchanger
- Tubular type design
- Designed for normal expansion and contraction
- Round surfaces create minimum resistance to air flow for excellent heat transfer
- Heat exchanger has been laboratory life cycle tested in excess of industry standards
- Compact size of heat exchanger permits low overall design of furnace cabinet

Burner Orifice/Air Intake Assembly

- Burner assembly has a single orifice located between the gas valve and the air intake assembly
- Orifice is precisely matched to the burner input
- Burner can be removed for servicing

SureLight® Hot Surface Ignitor

- Tough, reliable, long-life, trouble-free performance
- Silicon nitride ignitor
- Cemented to steatite block for protection against current leakage
- Ignition leads are constructed of nickel plated copper and are enclosed in high temperature Teflon® insulation for dependable operation

Modulating Gas Control Valve

- 24 volt redundant combination modulating gas control valve combines manual shut off switch (On-Off), automatic electric valve (dual) and gas pressure regulation into a compact combination control

Variable-Speed Combustion Air Inducer

- Heavy duty variable-speed blower prepurges heat exchanger and safely vents flue products
- Pressure switch proves blower operation before allowing gas valve to open
- Operates only during heating cycle

Thermal Switch

- Factory installed on air/fuel intake assembly
- Automatic reset
- Switch provides protection from abnormal operating conditions

FEATURES

HEATING SYSTEM (continued)

Limit Control

- Primary limit is accurately located on vestibule panel on all units
- Automatic reset

Optional Accessories

Natural Gas to LPG/Propane Conversion Kit (60K and 80K Input Furnaces Only)

- Required for field changeover from natural gas to LPG/Propane
- Includes gas and air orifices

Vent Adaptor (Upflow Applications Only)

- Allows venting through a masonry chimney without the need of a flue liner

- Manual reset temperature sensor protects against abnormal operating conditions

- Sensor wiring may be routed from either side of adaptor

- Minimum winter design temperatures:

- -10°F when used with interior masonry chimneys

- +5°F when used with exterior masonry chimneys

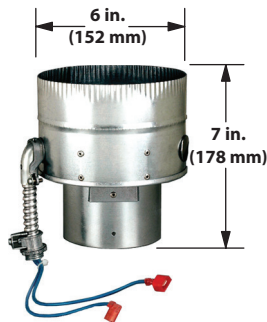

NOTE - Refer to Winter Design Temperatures Map on page 7 for application information. Also refer to the installation instructions for detailed information.

BLOWER

- Direct drive blower
- Statically and dynamically balanced
- Resiliently mounted
- Blower assembly easily removed for servicing

Power Saver™ Constant Torque Blower Motor

- DC Brushless Motor
- High Efficiency Constant Torque
- ECM (Electronically Commutated Motor)
- Motor is programmed to provide constant torque at each of the selectable speeds
- Motor is controlled by the Integrated Furnace Control
- Blower speeds are easily changed on the integrated furnace control
- See blower performance tables

CONTROLS

SureLight® Integrated Furnace Control

- Control contains all necessary controls and relays to operate furnace
- Combustion air inducer is operated by the integrated furnace control
- Prior to ignition, a pre-purge cycle for 15 seconds is initiated
- After the main burners are turned off, a post-purge cycle for 5 seconds is run
- Flame sensor assures safe and reliable operation
- Should loss of flame occur the integrated furnace control will initiate 4 re-attempts at ignition before locking out unit operation for 60 minutes
- Watchguard type circuit automatically resets ignition controls after one hour of continuous thermostat demand after unit lockout, eliminating nuisance calls for service
- Fan control consists of adjustable blower timed-off delay (60, 90, 120, 180 seconds - factory setting 90 seconds) and fixed blower timed-on delay (30 seconds - heating, 2 seconds - cooling)
- For air-conditioning applications, blower is automatically energized on thermostat demand for cooling
- Control has low speed continuous blower speed setting for humidifier or air cleaner operation
- Two accessory terminals furnished for additional power supply requirements for 120 volt (less than 1 amp) power humidifiers and powered air cleaners. One additional terminal is furnished for power supply requirements for 24V (less than 0.5 amp) low voltage accessories
- Ignition control has single red LED to indicate status and as an aid in troubleshooting
- Last five codes are stored in non-volatile memory (accessible by recall button on control) for servicing

24 Volt Transformer

- Furnished and factory installed on outside of control box. 40VA transformer has circuit breaker wired in series

Field Wiring Make-up Box

- Furnished for line voltage wiring
- Factory installed internally on left side of furnace
- Box may be installed on right side of furnace

FEATURES

CONTROLS (continued)

Optional Accessories

iComfort® E30 Smart Wi-Fi Thermostat

- Wi-Fi enabled, electronic 7-day, universal, multi-stage, programmable, touchscreen thermostat
- 3 Heat/2 Cool
- Auto-changeover
- Controls dehumidification during cooling mode and humidification during heating mode
- Offers enhanced capabilities including humidification / dehumidification / dewpoint measurement and control, Humiditrol® control, and equipment maintenance reminders
- Easy to read 7 in. color touchscreen (measured diagonally)
- LCD display with backlight shows the current and set temperature, time, inside relative humidity, system status (operating mode and schedules) and outside temperature (optional outdoor sensor required)
- Smooth Setback Recovery starts system early to achieve setpoint at start of program period
- Compressor short-cycle protection (5 minutes)
- Up to four separate schedules are available plus Schedule IQ™
- One-Touch Away Mode - A quick and easy way to set the cooling and heating setpoints while away
- Smart Away™ - Uses geo-fencing technology to determine when the homeowner is within a predetermined distance from the home to operate the system when leaving, away and arriving
- Wi-Fi remote monitoring and adjustment through a home wireless network for desktop PCs, laptops and apps for smartphones or tablets
- Smart home automation compatible with Apple HomeKit™, Amazon Alexa®, Google Assistant and IFTTT
- Service Dashboard features online real-time monitoring of installed iComfort® thermostats
- High Definition Color Display and Subbase, Smart Hub Controller, wallplate (for retrofit installations) furnished for easy installation
- See the iComfort® E30 Smart Wi-Fi Thermostat Product Specifications bulletin for more information



Remote Outdoor Temperature Sensor

- Used with the E30 Smart Wi-Fi Thermostat
- When installed outdoors, sensor allows thermostat to display outdoor temperature

NOTE - Sensor is required for Enhanced Dehumidification Control (EDA) applications.



Thermostat

- Thermostat is not furnished with unit
- See Lennox Price Book for selection

Blower Relay Kit (For Use With Two-Stage Outdoor Units)

- Allows furnace blower speed changes when matched with two-stage air conditioners or heat pumps

Furnace Twinning Kit

- Required to operate two furnaces simultaneously
- Kit consists of twinning relays, quick connect terminals and mounting hardware
- Used for single-stage heating/single-stage cooling with a single-stage thermostat

Night Service Kit

- Contains most commonly used service parts:
 - Furnace Control
 - Ignitor
 - Flame Sensor
 - Gas Valve
 - Transformer

FILTER (not furnished)

- Filter and provisions for external mounting must be field provided

Optional Accessories

Air Filter and Rack Kit for Horizontal Return Air (End) Applications

- Washable or vacuum cleanable polyurethane frame type filter and external end return air rack
- Rack has filter door for servicing
- Flanges on rack for duct connection
- Field installed
- See dimension drawing

Air Filter and Rack Kit for Upflow Side Return Air

- NOTE** - Not for use with Return Air Base
- Washable or vacuum cleanable polyurethane frame type filter and external side return air rack available for field installation
 - Available in single and ten pack kits
 - Rack has filter door for servicing
 - Flanges on rack for duct connection
 - Field installs on either side of unit cabinet
 - See dimension drawing

FEATURES

CABINET

NOTE - Flue outlet is on top of cabinet only! If furnace is installed horizontally, the flue must be vented vertically after exiting the top of the cabinet (upflow furnace position) or end of the cabinet (horizontal furnace position)!

- Low-profile, narrow width cabinet allows easy installation
- Heavy-gauge, cold rolled steel construction
- Pre-painted cabinet finish
- Flanges provided on supply air opening for ease of plenum connection or alignment with indoor coil
- Insulated cabinet with foil faced insulation on sides and back of heating compartment and mat faced insulation in blower compartment
- Sealed blower compartment
- Inner blower compartment access panel seals blower compartment from air leakage
- Cabinet door can be removed without any tools
- Complete service access
- Safety interlock switch automatically shuts off power to unit when blower compartment access panel is removed
- Gas piping and electrical inlets are provided in both sides of cabinet on "B" and "C" width models.

NOTE - Gas piping is only available on the left side of the cabinet on "A" width models.

Bottom/Side Return Air Entry:

- Upflow/horizontal with bottom return air entry:
 - Remove furnished bottom seal panel from cabinet
- Upflow only with side return-air entry:
 - Corners are marked on either side of cabinet for return air cut-out
- See dimension drawings

NOTE - 60C size units that require air volumes over 1800 cfm must have one of the following:

- Single side return air and Optional Return Air Base with transition that must accommodate required 20 x 25 x 1 inch air filter to maintain proper velocity
- Bottom return air
- Return air from both sides
- Bottom and one side return air
- See Blower Performance Tables for additional information

Coil Match-Up

- All furnaces exactly match Lennox cased upflow indoor coils and horizontal indoor coils with same letter designation (A, B, C, D) in model number
- No adaptor required
- Engaging holes furnished on cabinet for alignment
- Lennox uncased coils match furnaces without any overhang but require an optional adaptor base or field fabricated transition to match furnace opening

- See coil bulletin for additional information

Low Leakage Cabinet

- All models have less than 2% air leakage
- Meets ANSI/ASHRAE Standard 193-2010 "Method of Test for Determining the Air Tightness of HVAC Equipment"

Optional Accessories

Horizontal Suspension Kit

- Provides suspension of unit and indoor coil in horizontal applications
- Allows complete service access
- Consists of corner mounted hanging brackets with vibration isolators, return air end support rail and hardware for assembly
- Metal hanging straps must be field provided

Return Air Base

NOTE - On furnaces with side return air and condensate trap on the same side of the cabinet, a field fabricated transition or Return Air Base is required when using an IAQ product higher than 14-3/16 inches installed next to the unit and serviced from the front. IAQ products higher than 20 inches require a field fabricated transition.

NOTE - Must be used for 60C size models with air volumes over 1800 cfm in upflow applications when only one side return is required.

- Cabinet is shipped flat for easy field assembly
- Pre-painted steel to match the furnace
- See Dimension Drawing

High Performance Economizer (Commercial Applications Only)

- Designed for applications requiring outdoor air to be utilized in a commercial HVAC system
- Allows the entry of fresh outdoor air for free cooling, reducing the requirement for mechanical cooling
- Heavy gauge galvanized steel cabinet lined with thick fiberglass insulation
- Mixed air sensor, outdoor air sensor and 24VAC transformer furnished
- Approved for California Title 24 building standards. ASHRAE 90.1-2010 compliant
- See separate Product Specifications bulletin for additional information and available control and sensor options

99% WINTER DESIGN TEMPERATURES FOR THE CONTIGUOUS UNITED STATES



This map is a necessarily generalized guide to temperatures in the contiguous United States. Temperatures shown for areas such as mountainous regions and large urban centers may not be accurate. The data used to develop this map was taken from the 1993 ASHRAE Fundamentals Handbook (Chapter 24, Table 1: Climate Conditions for the United States).

Reprinted with permission from NFPA 54: National Fuel Gas Code 1999, National Fire Protection Association, Quincy, MA 02269. This reprinted material is not the complete and official position of the National Fire Protection Association on the referenced subject, which is represented only by the standard in its entirety.

HIGH ALTITUDE OPERATION

NOTE - Units may be installed at altitudes up to 4500 ft. above sea level without any modification.

INSTALLATION CLEARANCES

UPFLOW POSITION

Vent Type	Type B1	Type C
Sides	1 (25)	¹ 1 (25)
Rear	1 (25)	1 (25)
Top	1 (25)	1 (25)
Front	¹ 2-1/4 (57)	² 2-1/4 (57)
Front (service/alcove)	24 (610)	24 (610)
Floor	Combustible	Combustible
Flue	1 (25)	6 (152)

NOTE - Air for combustion must conform to the methods outlined in the National Fuel Gas Code (NFPA 54/ANSI-Z223.1).

NOTE - In the U.S. flue sizing must conform to the methods outlined in the current National Fuel Gas Code (NFPA 54/ANSI-Z223.1) or applicable provisions of local building codes.

¹ Left side requires 3 in. if single wall vent is used on 14-1/2 in. cabinets, 2 in. on 17-1/2 in. cabinets.

² 4-1/2 in. if single wall vent pipe is used.

HORIZONTAL POSITION

Vent Type	Type B1	Type C
End	¹ 2	¹ 2
Rear	1 (25)	1 (25)
Top	¹ 1 (25)	¹ 1 (25)
Front	2-1/4 (57)	2-1/4 (57)
Front (service)	24 (610)	24 (610)
Floor	Combustible	Combustible
Flue	1 (25)	6 (152)

NOTE - Air for combustion must conform to the methods outlined in the National Fuel Gas Code (NFPA 54/ANSI-Z223.1).

NOTE - In the U.S. flue sizing must conform to the methods outlined in the current National Fuel Gas Code (NFPA 54/ANSI-Z223.1) or applicable provisions of local building codes.

¹ Line contact installation permissible between jacket top or sides and building joists.

SPECIFICATIONS

Gas	Model No.	EL180UH040NE36A	EL180UH060NE36A	EL180UH080NE48B	EL180UH100NE60C
Heating Performance	AHRI Ref. No.	202028472	202028473	202028474	202028475
	¹ AFUE	80%	80%	80%	80%
	Input - Btuh	40,000	60,000	80,000	100,000
	Output - Btuh	32,700	49,000	70,500	81,500
	Temperature rise range - °F	20 - 50	30 - 60	35 - 65	35 - 65
Gas Manifold Pressure (in. w.g.) Natural Gas Only		1.8	3.4	3.4	304
High Static - in. w.g.		0.50	0.50	0.50	0.50
Connections in.	Flue connection - in. round	4	4	4	4
	Gas pipe size IPS	1/2	1/2	1/2	1/2
Indoor Blower	Wheel nominal dia. x width - in.	10 x 8	10 x 8	10 x 10	11-1/2 x 10
	Motor Type	DC Brushless	DC Brushless	DC Brushless	DC Brushless
	Motor output - hp	1/2	1/2	3/4	1
	Tons of add-on cooling	1.5 - 3	1.5 - 3	2.5 - 4	3 - 5
	Air Volume Range - cfm	350 - 1380	395 - 1415	750 - 1785	920 - 2315
Electrical Data	Voltage	120 volts - 60 hertz - 1 phase			
	Blower motor full load amps	6.8	6.8	8.4	10.9
	Maximum overcurrent protection	15	15	15	15
Shipping Data	lbs. - 1 package	113	113	125	149

NOTE - Filters and provisions for mounting are not furnished and must be field provided.

¹ Annual Fuel Utilization Efficiency based on DOE test procedures and according to FTC labeling regulations. Isolated combustion system rating for non-weatherized furnaces.

OPTIONAL ACCESSORIES - ORDER SEPARATELY

	"A" Width Models	"B" Width Models	"C" Width Models	
CABINET ACCESSORIES				
Horizontal Suspension Kit - Horizontal only	51W10	51W10	51W10	
Return Air Base - Upflow only	65W75	50W98	50W99	
High Performance Economizer (Commercial Only)	10U53	10U53	10U53	
CONTROLS				
iComfort® E30 Smart Wi-Fi Thermostat	20A65	20A65	20A65	
Remote Outdoor Temperature Sensor	X2658	X2658	X2658	
Blower Relay Kit (for two-stage outdoor units)	85W66	85W66	85W66	
Furnace Twinning Kit	16W72	16W72	16W72	
FILTERS				
¹ Air Filter and Rack Kit	Horizontal (end)	87L95	87L96	87L97
	Size of filter - in.	14 x 25 x 1	18 x 25 x 1	20 x 25 x 1
	Side Return Single	44J22	44J22	44J22
	Ten Pack	66K63	66K63	66K63
	Size of filter - in.	16 x 25 x 1	16 x 25 x 1	16 x 25 x 1
SERVICE KIT				
Night Service Kit	84W47	84W47	84W47	
VENTING				
Vent Adaptor - 6 in. conn. size upflow applications only	18M79	18M79	18M79	

¹ Cleanable polyurethane, frame-type filter.

GAS HEAT ACCESSORIES

Input	Natural Gas to LPG/Propane Kit
	0 - 4500 ft.
040	N/A
060	20P40
080	20P41
100	N/A

NOTE - Natural Gas to LPG/Propane Kit is not available for 40K Input furnaces.

DIMENSIONS

UNIT - UPFLOW POSITION

- ¹ NOTE - 60C size units that require air volumes over 1800 cfm must have one of the following:
1. Single side return air and Optional Return Air Base with transition that must accommodate required 20 x 25 x 1 inch (508 x 635 x 25 mm) air filter to maintain proper velocity.
 2. Bottom return air.
 3. Return air from both sides.
 4. Bottom and one side return air.
- See Blower Performance Tables for additional information.

² Flue outlet may be horizontal but furnace must be vented vertically

³ Optional External Side Return Air Filter Kit is not for use with the optional Return Air Base.

³ NOTE - Gas entry is only available on the left side of the cabinet for "A" width cabinet models.

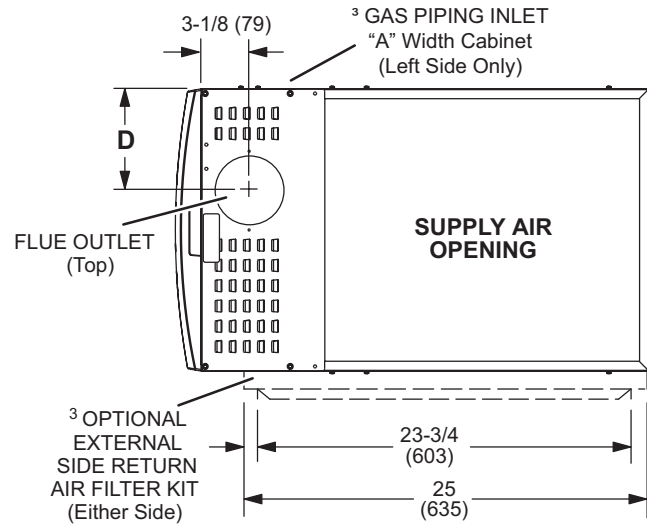

TOP VIEW

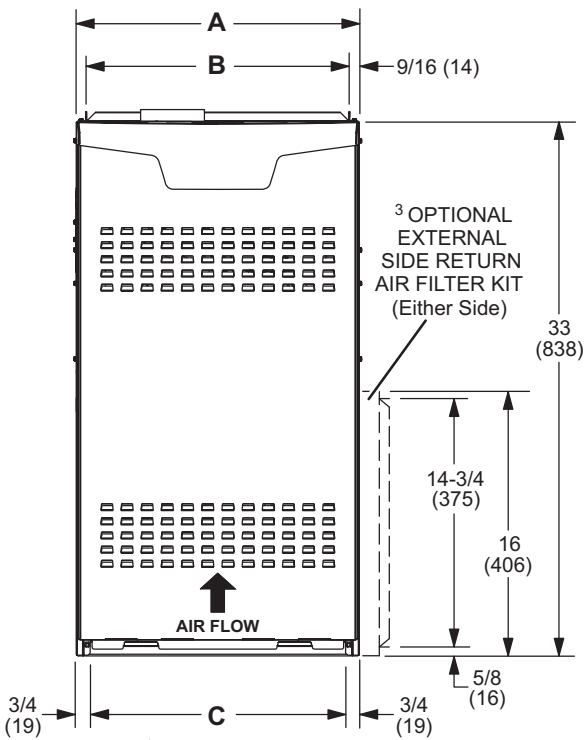

FRONT VIEW

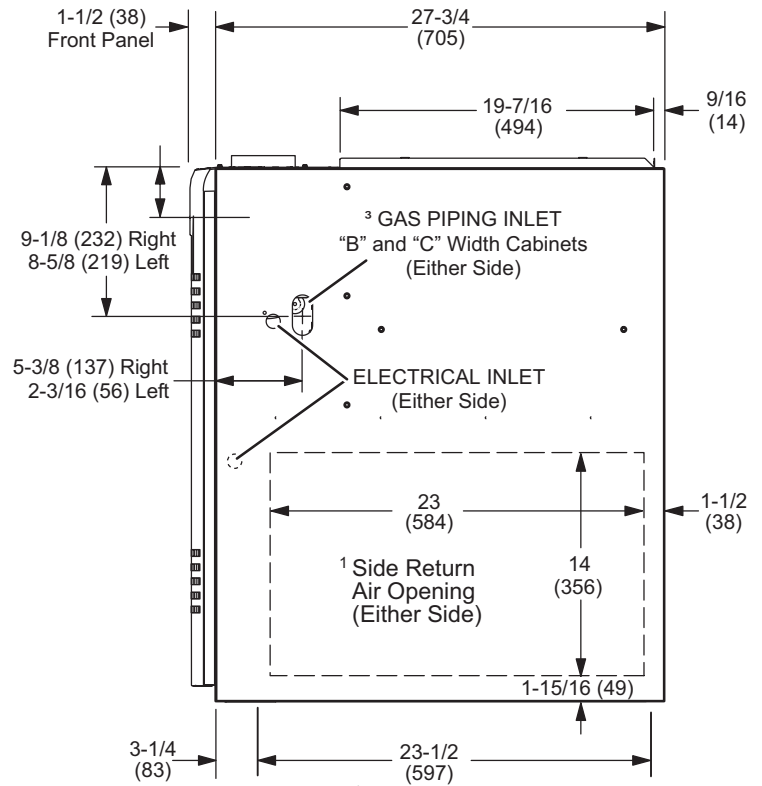

SIDE VIEW

Model No.	A		B		C		D	
	in.	mm	in.	mm	in.	mm	in.	mm
EL180UH040NE36A	14-1/2	368	13-3/8	340	13	330	4-3/4	121
EL180UH060NE36A								
EL180UH080NE48B	17-1/2	446	16-3/8	416	16	406	6-1/4	159
EL180UH100NE60C	21	533	19-7/8	504	19-1/2	495	8	203

LEFT-HAND AIR DISCHARGE

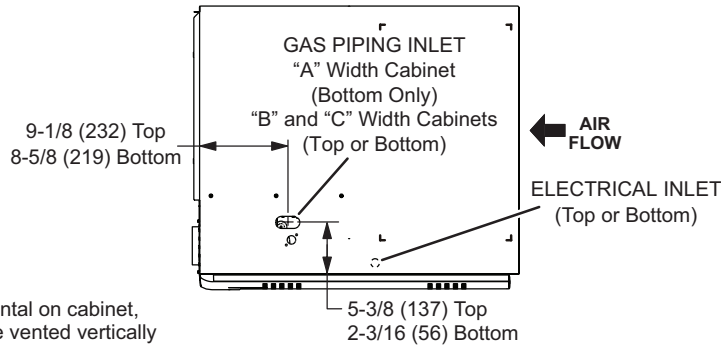

¹ Flue outlet is horizontal on cabinet, but furnace must be vented vertically

TOP VIEW

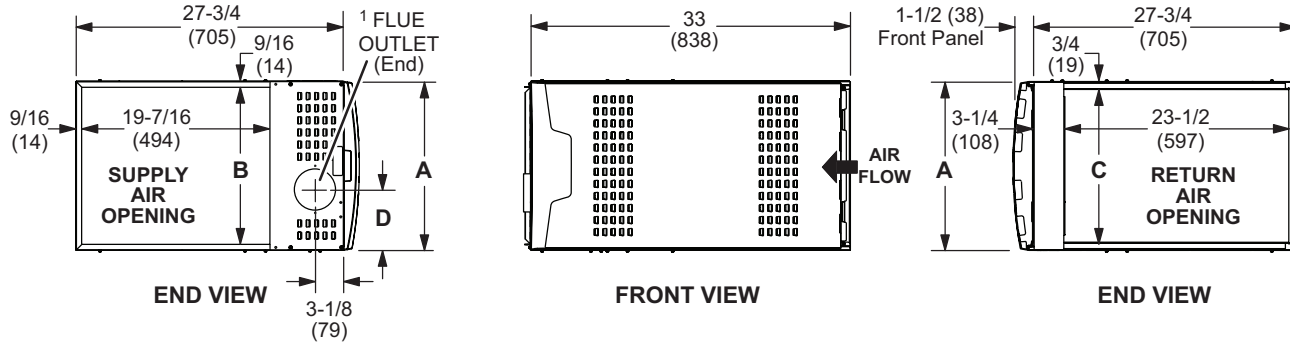

RIGHT-HAND AIR DISCHARGE

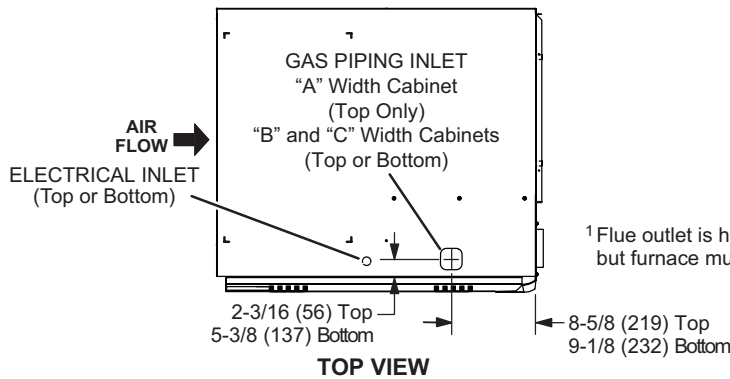

¹ Flue outlet is horizontal on cabinet, but furnace must be vented vertically

TOP VIEW

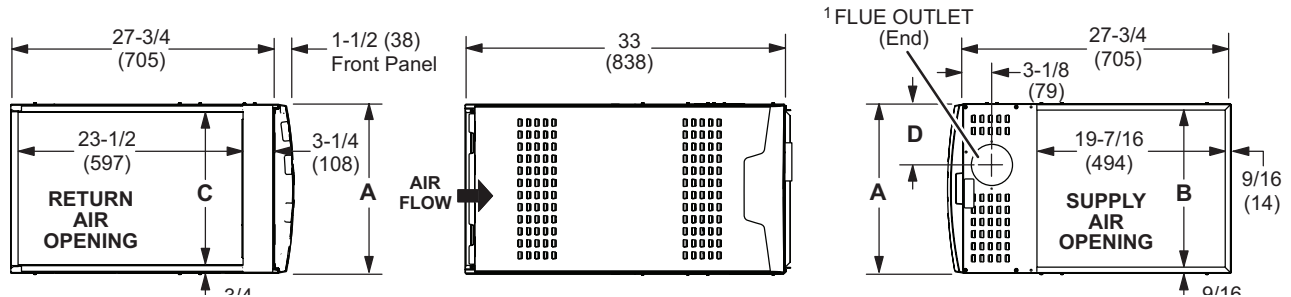

Model No.	A		B		C		D	
	in.	mm	in.	mm	in.	mm	in.	mm
EL180UH040NE36A	14-1/2	368	13-3/8	340	13	330	4-3/4	121
EL180UH060NE36A								
EL180UH080NE48B	17-1/2	446	16-3/8	416	16	406	6-1/4	159
EL180UH100NE60C	21	533	19-7/8	504	19-1/2	495	8	203

HORIZONTAL (END) FILTER KIT

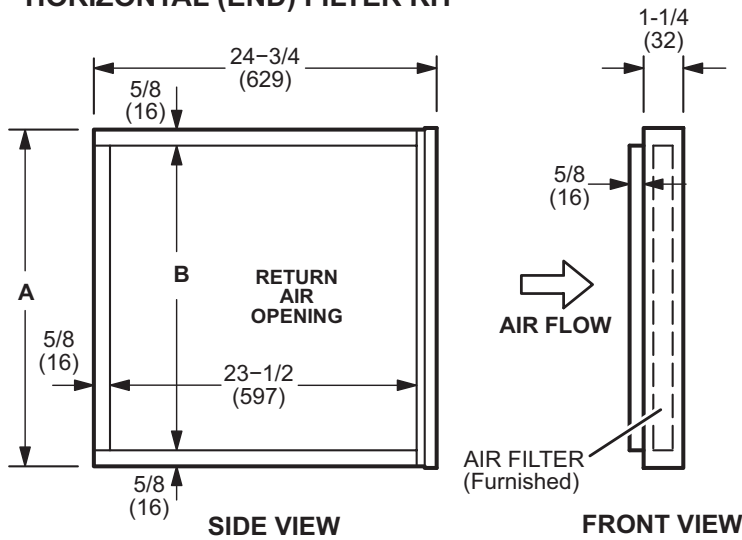

Furnace Cabinet Width	Catalog Number	A		B	
		in.	mm	in.	mm
A	87L95	14	356	12-3/4	324
B	87L96	18	457	16-3/4	425
C	87L97	21	533	18-3/4	476

**Optional Return Air Base
(Upflow Applications Only - For use with A, B and C width cabinets)**

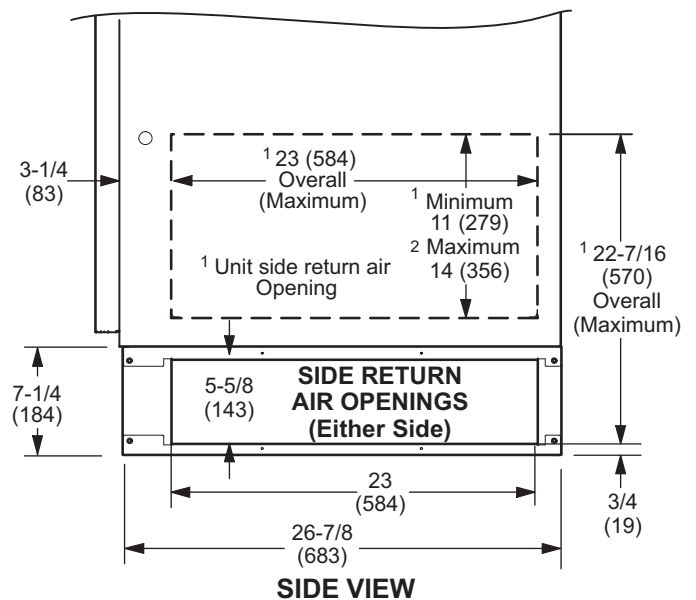
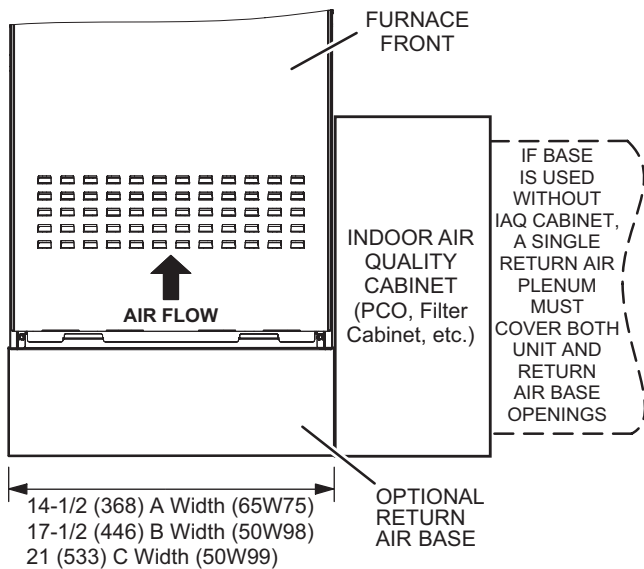

NOTE- Optional Side Return Air Filter Kits are not for use with Optional Return Air Base.

- ¹ Both the unit return air opening and the base return air opening must be covered by a single plenum or IAQ cabinet. Minimum unit side return air opening dimensions for units requiring 1800 cfm or more of air (W x H): 23 x 11 in. (584 x 279 mm). The opening can be cut as needed to accommodate plenum or IAQ cabinet while maintaining dimensions shown. Side return air openings must be cut in the field. There are cutting guides stenciled on the cabinet for the side return air opening. The size of the opening must not extend beyond the markings on the furnace cabinet.
- ² To minimize pressure drop, the largest opening height possible, up to 14 in. (356 mm), is preferred.

UPFLOW POSITION

Model No	C35/CX35 Cased				C35 Uncased			
	A		B		A		B	
	in.	mm	in.	mm	in.	mm	in.	mm
C35/CX35-18/24A C35/CX35-18/24B	16-1/2	419	49-1/2	1257	14-1/8	359	47-1/8	1197
C35/CX35-24A C35/CX35-24B	18-1/2	470	51-1/2	1308	16-3/8	416	49-3/8	1254
---	20-1/2	521	53-1/2	1359	---	---	---	---
C35/CX35-30A C35/CX35-30B	22-1/2	572	55-1/2	1410	20-3/4	527	53-3/4	1365
C35/CX35-30/36A C35/CX35-30/36B C35/CX35-30/36C	24-1/2	622	57-1/2	1461	22-1/4	565	55-1/4	1403
C35/CX35-36A C35/CX35-36B	24-1/2	622	57-1/2	1461	22-3/8	568	55-3/8	1407
---	24-1/2	622	57-1/2	1461	---	---	---	---
C35/CX35-48B C35/CX35-48C	27-1/2	699	60-1/2	1537	26-1/4	667	59-1/4	1505
---	24-1/2	622	57-1/2	1461	---	---	---	---
C35/CX35-49C	29-1/2	749	62-1/2	1588	28-1/2	724	61-1/2	1562
C35/CX35-50/60C	27-1/2	699	60-1/2	1537	25-7/8	657	58-7/8	1495
CX35-60C	31-1/2	800	64-1/2	1638	30-5/8	778	63-5/8	1616

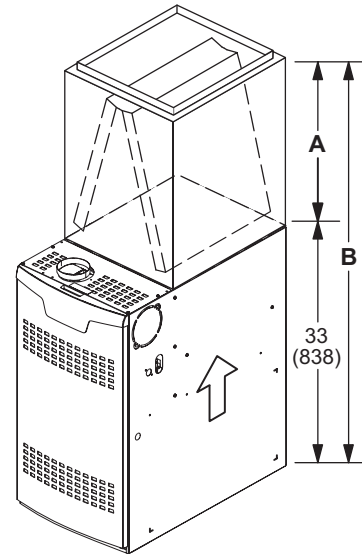

HORIZONTAL POSITION

Model No.		A		B	
		in.	mm	in.	mm
CH35					
CH35-18A, CH35-24A, CH35-24B, CH35-30B,	CH35-36A, CH35-36B, CH35-36C, CH35-42C, CH35-48C	26-1/2	673	59-1/2	1511
CH35-30A, CH35-42B, CH35-48B,	CH35-51C	31-1/2	880	64-1/2	1638
CHX35					
CHX35-18A, CHX35-24A, CHX35-24B, CHX35-30B,	CHX35-36A, CHX35-36B, CHX35-36C, CHX35-42C, CHX35-48C	26-1/2	673	59-1/2	1511
CHX35-30A, CHX35-42B, CHX35-48B,	CHX35-51/61C	31-1/2	880	64-1/2	1638

BLOWER DATA

EL180UH040NE36A PERFORMANCE (Less Filter)

External Static Pressure in. w.g.	Air Volume / Watts at Various Blower Speeds									
	High (Black)		Medium-High (Brown)		Medium (Blue)		Medium-Low (Yellow)		Low (Red)	
	cfm	Watts	cfm	Watts	cfm	Watts	cfm	Watts	cfm	Watts
0.00	1430	243	1200	140	1025	86	945	66	945	45
0.10	1395	253	1165	151	1005	99	940	75	930	50
0.20	1370	264	1130	157	930	99	825	80	795	68
0.30	1345	278	1100	170	895	110	775	85	650	63
0.40	1320	289	1085	182	875	120	745	90	615	70
0.50	1295	302	1035	189	820	126	705	102	545	76
0.60	1245	308	1010	200	795	135	655	107	515	85
0.70	1220	320	980	210	755	147	615	115	445	87
0.80	1200	332	930	215	700	152	570	121	400	95

EL180UH060NE36A PERFORMANCE (Less Filter)

External Static Pressure in. w.g.	Air Volume / Watts at Various Blower Speeds									
	High (Black)		Medium-High (Brown)		Medium (Blue)		Medium-Low (Yellow)		Low (Red)	
	cfm	Watts	cfm	Watts	cfm	Watts	cfm	Watts	cfm	Watts
0.00	1410	243	1190	141	1030	86	930	73	835	55
0.10	1380	251	1165	150	990	95	890	89	790	65
0.20	1360	264	1115	158	950	99	840	78	730	68
0.30	1315	278	1090	171	910	110	790	89	660	61
0.40	1295	290	1070	182	865	122	740	93	600	71
0.50	1270	300	1025	191	825	127	695	103	545	75
0.60	1235	300	1000	197	785	136	650	108	495	84
0.70	1215	317	975	208	750	147	615	118	450	88
0.80	1185	331	920	216	700	153	555	121	390	96

EL180UH080NE48B PERFORMANCE (Less Filter)

External Static Pressure in. w.g.	Air Volume / Watts at Various Blower Speeds									
	High (Black)		Medium-High (Brown)		Medium (Blue)		Medium-Low (Yellow)		Low (Red)	
	cfm	Watts	cfm	Watts	cfm	Watts	cfm	Watts	cfm	Watts
0.00	1785	344	1570	236	1455	183	1390	161	1230	116
0.10	1745	360	1535	249	1420	194	1360	172	1190	129
0.20	1725	373	1500	266	1375	212	1310	189	1145	135
0.30	1695	386	1475	279	1340	224	1280	201	1100	146
0.40	1665	405	1440	293	1305	237	1235	208	1065	156
0.50	1640	418	1410	307	1275	250	1190	223	1015	170
0.60	1595	433	1370	323	1235	263	1160	234	970	182
0.70	1570	446	1330	336	1190	277	1120	249	930	187
0.80	1530	461	1300	349	1155	289	1095	260	900	201

BLOWER DATA

EL180UH100NE60C (Less Filter)

External Static Pressure in. w.g.	Air Volume / Watts at Different Blower Speeds																			
	Bottom Return Air, Side Return Air with Return Air from Both Sides or Return Air from Bottom and One Side.										Single Side Return Air - Air volumes in bold require Optional Return Air Base <u>and</u> field fabricated transition to accommodate 20 x 25 x 1 in. air filter in order to maintain proper air velocity.									
	High (Black)		Medium-High (Brown)		Medium (Blue)		Medium-Low (Yellow)		Low (Red)		High (Black)		Medium-High (Brown)		Medium (Blue)		Medium-Low (Yellow)		Low (Red)	
	cfm	Watts	cfm	Watts	cfm	Watts	cfm	Watts	cfm	Watts	cfm	Watts	cfm	Watts	cfm	Watts	cfm	Watts	cfm	Watts
0.00	2205	623	1950	415	1710	275	1575	220	1425	160	2235	595	1945	382	1725	262	1590	202	1430	165
0.10	2175	639	1910	427	1685	287	1545	234	1400	176	2205	611	1915	397	1695	280	1550	218	1400	193
0.20	2145	658	1885	449	1635	309	1490	246	1325	181	2165	629	1885	424	1660	293	1510	235	1335	175
0.30	2100	681	1845	466	1605	327	1465	259	1275	196	2135	652	1850	441	1615	312	1475	247	1275	182
0.40	2095	700	1815	481	1565	337	1415	280	1225	204	2085	676	1800	456	1580	330	1430	261	1240	197
0.50	2045	717	1780	499	1525	356	1375	286	1195	218	2055	685	1775	474	1535	347	1395	281	1195	206
0.60	2025	737	1735	516	1500	374	1350	304	1145	230	2025	700	1755	494	1505	359	1355	300	1155	222
0.70	1995	746	1715	533	1465	389	1320	323	1090	248	1990	720	1725	515	1480	377	1310	308	1120	237
0.80	1950	769	1675	547	1430	401	1255	331	1065	259	1965	742	1685	532	1445	396	1275	325	1060	248

REVISIONS

Sections	Description of Change
Optional Accessories	E30 catalog number updated.



Visit us at www.Lennox.com

For the latest technical information, www.LennoxPros.com

Contact us at 1-800-4-LENNOX

NOTE - Due to Lennox' ongoing commitment to quality, Specifications, Ratings and Dimensions subject to change without notice and without incurring liability. Improper installation, adjustment, alteration, service or maintenance can cause property damage or personal injury. Installation and service must be performed by a qualified installer and servicing agency.

©2020 Lennox Industries, Inc.